



US009242070B2

(12) **United States Patent**  
**Tieu**

(10) **Patent No.:** **US 9,242,070 B2**  
(45) **Date of Patent:** **Jan. 26, 2016**

(54) **SYSTEM AND METHOD FOR LOCATING DETACHMENT ZONE OF A DETACHABLE IMPLANT**

(75) Inventor: **Tai D. Tieu**, Fountain Valley, CA (US)

(73) Assignee: **MicronVention, Inc.**, Tustin, CA (US)

(\* ) Notice: Subject to any disclaimer, the term of this patent is extended or adjusted under 35 U.S.C. 154(b) by 1506 days.

(21) Appl. No.: **12/340,546**

(22) Filed: **Dec. 19, 2008**

(65) **Prior Publication Data**

US 2009/0163780 A1 Jun. 25, 2009

**Related U.S. Application Data**

(60) Provisional application No. 61/016,154, filed on Dec. 21, 2007.

(51) **Int. Cl.**

*A61M 29/00* (2006.01)  
*A61B 5/00* (2006.01)

(Continued)

(52) **U.S. Cl.**

CPC ..... *A61M 25/0082* (2013.01); *A61B 17/1214* (2013.01); *A61B 17/12022* (2013.01); *A61B 17/12109* (2013.01); *A61B 17/12113* (2013.01); *A61B 17/12122* (2013.01); *A61B 17/12154* (2013.01); *A61F 2/95* (2013.01); *A61M 25/0108* (2013.01); *A61B 2017/12068* (2013.01); *A61F 2/966* (2013.01); *A61F 2002/30668* (2013.01); *A61F 2002/9505* (2013.01); *A61F 2250/0001* (2013.01); *A61M 25/0068* (2013.01); *A61M 2025/0042* (2013.01); *A61M 2025/0681* (2013.01); *A61M 2205/3331* (2013.01); *A61M 2205/3368* (2013.01); *A61M 2205/3375* (2013.01); *A61M 2205/3653* (2013.01)

(58) **Field of Classification Search**

CPC ..... *A61M 25/0108*; *A61M 2205/18*; *A61B 17/12022*; *A61B 17/12113*; *A61B 2017/12068*

USPC ..... 606/200, 108; 600/301, 424  
See application file for complete search history.

(56) **References Cited**

U.S. PATENT DOCUMENTS

4,346,712 A 8/1982 Handa et al.  
4,364,392 A 12/1982 Strother et al.

(Continued)

FOREIGN PATENT DOCUMENTS

AU 2005/276980 B2 3/2006  
CA 2493016 A1 2/2004

(Continued)

OTHER PUBLICATIONS

United States Patent and Trademark Office, Notice of Allowance mailed Feb. 15, 2012 in U.S. Appl. No. 12/340,616, 17 pages.

(Continued)

*Primary Examiner* — Katherine Rodjom

(74) *Attorney, Agent, or Firm* — Inskeep IP Group, Inc.

(57) **ABSTRACT**

A system and method for quickly detaching an implant and for locating the detachment zone of a detachable implant. A sensor determines a sudden change in the local environment as the sensor passes from within a microcatheter to being exposed to the vasculature. The sensor may be a temperature sensor, ultrasonic sensor, pressure sensor or the like. If the detachable implant assembly uses a heater coil to detach the implant, the heater coil may be used as a sensor. Additionally, the implant itself may be used as a sensor if a change in electrical resistance is detectable as the implant exits the microcatheter and changes shape.

**6 Claims, 6 Drawing Sheets**

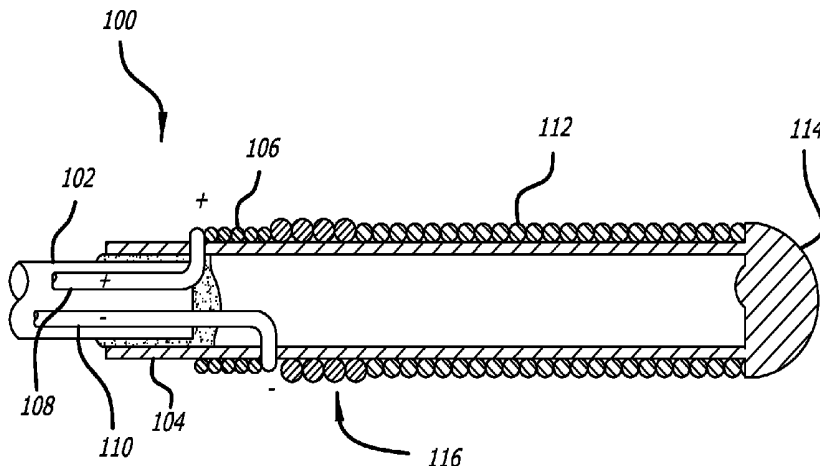

(51)	<b>Int. Cl.</b>								
	<i>A61M 25/00</i>	(2006.01)		5,634,936 A	6/1997	Linden et al.			
	<i>A61B 17/12</i>	(2006.01)		5,639,277 A	6/1997	Mariant et al.			
	<i>A61F 2/95</i>	(2013.01)		5,645,558 A	7/1997	Horton			
	<i>A61M 25/01</i>	(2006.01)		5,658,308 A	8/1997	Snyder			
	<i>A61F 2/966</i>	(2013.01)		5,667,767 A	9/1997	Greff et al.			
	<i>A61F 2/30</i>	(2006.01)		5,669,931 A	9/1997	Kupiecki et al.			
	<i>A61M 25/06</i>	(2006.01)		5,690,667 A	11/1997	Gia			
				5,690,671 A	11/1997	McGurk et al.			
				5,700,258 A	12/1997	Mirigian et al.			
				5,702,361 A	12/1997	Evans et al.			
				5,718,711 A	2/1998	Berenstein et al.			
				5,722,989 A	3/1998	Fitch et al.			
				5,725,568 A	3/1998	Hastings			
				5,733,329 A	3/1998	Wallace et al.			
				5,743,905 A	4/1998	Eder et al.			
				5,749,891 A	5/1998	Ken et al.			
				5,749,894 A	5/1998	Engelson			
				5,749,921 A	5/1998	Lenker et al.			
				5,750,585 A	5/1998	Park et al.			
				5,759,161 A	6/1998	Ogawa et al.			
				5,766,204 A	6/1998	Porter et al.			
				5,766,219 A	6/1998	Horton			
				5,792,154 A	8/1998	Doan et al.			
				5,800,454 A	9/1998	Jacobsen et al.			
				5,800,455 A	9/1998	Palermo et al.			
				5,814,062 A	9/1998	Sepetka et al.			
				5,823,198 A	10/1998	Jones et al.			
				5,830,178 A	11/1998	Jones et al.			
				5,830,230 A	11/1998	Berryman et al.			
				5,846,210 A	12/1998	Ogawa et al.			
				5,846,247 A	12/1998	Unsworth et al.			
				5,851,206 A	12/1998	Guglielmi et al.			
				5,851,508 A	12/1998	Greff et al.			
				5,853,418 A	12/1998	Ken et al.			
				5,891,058 A	4/1999	Taki et al.			
				5,891,130 A	4/1999	Palermo et al.			
				5,895,385 A	4/1999	Guglielmi et al.			
				5,902,254 A	5/1999	Magram			
				5,911,737 A	6/1999	Lee et al.			
				5,925,037 A	7/1999	Guglielmi et al.			
				5,925,059 A	7/1999	Palermo et al.			
				5,925,061 A	7/1999	Ogi et al.			
				5,941,888 A	8/1999	Wallace et al.			
				5,944,733 A	8/1999	Engelson			
				5,947,963 A	9/1999	Guglielmi			
				5,964,771 A	10/1999	Beyar et al.			
				5,964,797 A	10/1999	Ho			
				5,976,126 A	11/1999	Guglielmi et al.			
				5,976,131 A	11/1999	Guglielmi et al.			
				5,984,629 A	11/1999	Brodersen et al.			
				6,010,498 A	1/2000	Guglielmi			
				6,013,084 A	1/2000	Ken et al.			
				6,015,424 A	1/2000	Rosenbluth et al.			
				6,033,423 A	3/2000	Ken et al.			
				6,048,338 A	4/2000	Larson et al.			
				6,053,873 A	4/2000	Govari et al.			
				6,056,759 A	5/2000	Fiedler			
				6,059,815 A	5/2000	Lee et al.			
				6,063,070 A	5/2000	Eder			
				6,063,100 A	5/2000	Diaz et al.			
				6,066,133 A	5/2000	Guglielmi et al.			
				6,068,644 A	5/2000	Lulo et al.			
				6,083,220 A	7/2000	Guglielmi et al.			
				6,086,599 A	7/2000	Lee et al.			
				6,091,980 A *	7/2000	Squire et al. ....	600/381		
				6,102,932 A	8/2000	Kurz			
				6,117,142 A	9/2000	Goodson et al.			
				6,159,206 A *	12/2000	Ogawa .....	A61B 17/12022		
							606/29		
				6,165,178 A	12/2000	Bashiri et al.			
				6,193,728 B1	2/2001	Ken et al.			
				6,221,066 B1	4/2001	Ferrera et al.			
				6,224,609 B1	5/2001	Ressemann et al.			
				6,238,403 B1	5/2001	Greene, Jr. et al.			
				6,238,415 B1	5/2001	Sepetka et al.			
				6,277,126 B1	8/2001	Barry et al.			
				6,293,960 B1	9/2001	Ken			
				6,296,622 B1	10/2001	Kurz et al.			
				6,299,619 B1	10/2001	Greene, Jr. et al.			
(56)	<b>References Cited</b>								
	<b>U.S. PATENT DOCUMENTS</b>								
	4,402,319 A	9/1983	Handa et al.						
	4,512,338 A	4/1985	Balko et al.						
	4,545,367 A	10/1985	Tucci						
	4,551,132 A	11/1985	Pasztor et al.						
	4,638,803 A	1/1987	Rand						
	RE32,348 E	2/1987	Pevsner						
	4,735,201 A	4/1988	O'Reilly						
	4,795,741 A	1/1989	Leshchiner et al.						
	4,819,637 A	4/1989	Dormandy, Jr. et al.						
	4,944,746 A	7/1990	Iwata et al.						
	4,994,069 A	2/1991	Ritchart et al.						
	5,001,009 A	3/1991	Whitbourne						
	5,108,407 A	4/1992	Geremia et al.						
	5,122,136 A	6/1992	Guglielmi et al.						
	5,133,731 A	7/1992	Butler et al.						
	5,147,370 A	9/1992	McNamara et al.						
	5,163,952 A	11/1992	Froix						
	5,167,624 A	12/1992	Butler et al.						
	5,217,484 A	6/1993	Marks						
	5,226,911 A	7/1993	Chee et al.						
	5,250,071 A	10/1993	Palermo						
	5,256,146 A	10/1993	Ensminger et al.						
	5,258,042 A	11/1993	Mehta						
	5,261,916 A	11/1993	Engelson						
	5,269,030 A	12/1993	Pahno et al.						
	5,304,194 A	4/1994	Chee et al.						
	5,311,027 A	5/1994	Schuetz						
	5,312,415 A	5/1994	Palermo						
	5,331,027 A	7/1994	Whitbourne						
	5,334,201 A	8/1994	Cowan						
	5,334,210 A	8/1994	Gianturco						
	5,350,397 A	9/1994	Palermo et al.						
	5,354,295 A	10/1994	Guglielmi et al.						
	5,382,259 A	1/1995	Phelps et al.						
	5,382,260 A	1/1995	Dormandy, Jr. et al.						
	5,383,887 A	1/1995	Nadal						
	5,423,777 A	6/1995	Tajiri et al.						
	5,423,829 A	6/1995	Pham et al.						
	5,423,849 A	6/1995	Engelson et al.						
	5,443,454 A	8/1995	Tanabe et al.						
	5,443,478 A	8/1995	Purdy						
	5,443,495 A	8/1995	Buscemi et al.						
	5,469,867 A	11/1995	Schmitt						
	5,470,338 A	11/1995	Whitfield et al.						
	5,476,472 A	12/1995	Dormandy						
	5,498,227 A	3/1996	Mawad						
	5,498,250 A	3/1996	Prather						
	5,522,836 A	6/1996	Palermo						
	5,525,334 A	6/1996	Ito et al.						
	5,529,653 A	6/1996	Glastra						
	5,536,274 A	7/1996	Neuss						
	5,540,680 A	7/1996	Guglielmi et al.						
	5,569,245 A	10/1996	Guglielmi et al.						
	5,578,074 A	11/1996	Mirigian						
	5,580,568 A	12/1996	Greff et al.						
	5,582,619 A	12/1996	Ken						
	5,593,412 A	1/1997	Martinez et al.						
	5,601,600 A	2/1997	Ton						
	5,609,608 A	3/1997	Benett et al.						
	5,612,050 A	3/1997	Rowe et al.						
	5,614,204 A	3/1997	Cochrum						
	5,624,449 A	4/1997	Pham et al.						
	5,624,461 A	4/1997	Mariant						
	5,624,685 A	4/1997	Takahashi et al.						

(56)

## References Cited

## U.S. PATENT DOCUMENTS

			7,578,826 B2	8/2009	Gandhi et al.	
			7,582,101 B2	9/2009	Jones et al.	
			7,591,833 B2	9/2009	Jones et al.	
			7,608,089 B2	10/2009	Wallace et al.	
			7,628,797 B2	12/2009	Tieu et al.	
			7,651,513 B2	1/2010	Teoh et al.	
			7,691,118 B2	4/2010	Gorospe	
			7,708,754 B2	5/2010	Balgobin et al.	
			7,708,755 B2	5/2010	Davis, III et al.	
			7,740,637 B2	6/2010	Gandhi et al.	
			7,771,451 B2	8/2010	Ramzipoor	
			7,776,054 B2	8/2010	Gandhi et al.	
			7,780,680 B2	8/2010	Gandhi et al.	
			7,789,891 B2	9/2010	Wallace	
			2001/0029352 A1	10/2001	Gandhi et al.	
			2002/0046756 A1 *	4/2002	Laizzo et al. ....	128/899
			2002/0091380 A1	7/2002	Wheelock et al.	
			2002/0107534 A1	8/2002	Schaefer et al.	
			2002/0188341 A1	12/2002	Elliott	
			2003/0023262 A1	1/2003	Welch	
			2003/0045901 A1	3/2003	Opolski	
			2003/0069539 A1	4/2003	Gandhi et al.	
			2003/0125790 A1	7/2003	Fastovsky et al.	
			2004/0002731 A1	1/2004	Aganon et al.	
			2004/0002733 A1	1/2004	Teoh	
			2004/0034363 A1	2/2004	Wilson et al.	
			2004/0044385 A1	3/2004	Fenn et al.	
			2004/0204701 A1	10/2004	Cox et al.	
			2005/0021023 A1 *	1/2005	Guglielmi et al. ....	606/41
			2005/0043755 A1 *	2/2005	Wilson et al. ....	606/200
			2005/0118865 A1	6/2005	Henningesen	
			2005/0131523 A1	6/2005	Bashiri et al.	
			2005/0149108 A1	7/2005	Cox	
			2005/0154417 A1	7/2005	Sepetka et al.	
			2005/0171572 A1	8/2005	Martinez	
			2005/0222580 A1	10/2005	Gifford, III et al.	
			2005/0283182 A1	12/2005	Pierce et al.	
			2006/0025801 A1	2/2006	Lulo et al.	
			2006/0025803 A1	2/2006	Mitelberg et al.	
			2006/0036280 A1	2/2006	French et al.	
			2006/0052815 A1 *	3/2006	Fitz et al. ....	606/200
			2006/0079923 A1	4/2006	Chhabra et al.	
			2006/0116708 A1	6/2006	Ogawa et al.	
			2006/0135986 A1	6/2006	Wallace et al.	
			2006/0173488 A1	8/2006	Takeuchi et al.	
			2006/0184092 A1	8/2006	Atanasoska et al.	
			2006/0200192 A1	9/2006	Fitz et al.	
			2006/0241682 A1	10/2006	Kurz	
			2006/0241684 A1	10/2006	Wilson et al.	
			2006/0241685 A1	10/2006	Wilson et al.	
			2006/0253023 A1	11/2006	Lewis et al.	
			2006/0253149 A1	11/2006	Gandhi et al.	
			2006/0271098 A1	11/2006	Peacock, III	
			2006/0271099 A1	11/2006	Marks et al.	
			2006/0276826 A1	12/2006	Mitelberg et al.	
			2007/0055302 A1	3/2007	Henry et al.	
			2007/0100419 A1	5/2007	Licata et al.	
			2007/0104752 A1	5/2007	Lee et al.	
			2007/0167911 A1	7/2007	Gandhi et al.	
			2007/0185443 A1	8/2007	Euteneuer et al.	
			2007/0185457 A1	8/2007	Euteneuer et al.	
			2007/0191879 A1	8/2007	Gandhi et al.	
			2007/0208276 A1	9/2007	Kornkven Volk et al.	
			2007/0239141 A1	10/2007	Hartley et al.	
			2007/0239193 A1	10/2007	Simon et al.	
			2008/0103585 A1	5/2008	Monstadt et al.	
			2008/0119887 A1	5/2008	Que et al.	
			2008/0125855 A1	5/2008	Henkes et al.	
			2008/0133028 A1	6/2008	Wilson et al.	
			2008/0140111 A1	6/2008	Wilson et al.	
			2008/0140178 A1	6/2008	Rasmussen et al.	
			2008/0147201 A1	6/2008	Wilson et al.	
			2008/0172119 A1 *	7/2008	Yamasaki et al. ....	623/1.11
			2008/0221554 A1	9/2008	O'Connor et al.	
			2008/0283066 A1	11/2008	Delgado et al.	
			2008/0287982 A1	11/2008	Harreld	
			2009/0018653 A1	1/2009	Bashiri et al.	
			2009/0054905 A1	2/2009	Levy	
			2009/0062726 A1	3/2009	Ford et al.	

(56)

## References Cited

## U.S. PATENT DOCUMENTS

2009/0076540 A1 3/2009 Marks et al.  
 2009/0099592 A1 4/2009 Buiser et al.  
 2009/0138036 A1 5/2009 Nardone et al.  
 2009/0143786 A1 6/2009 Bashiri et al.  
 2009/0163780 A1 6/2009 Tieu  
 2009/0163986 A1 6/2009 Tieu et al.  
 2009/0177261 A1 7/2009 Teoh et al.  
 2009/0270901 A1 10/2009 Kelleher et al.  
 2009/0270903 A1 10/2009 Litzenberg et al.  
 2009/0275971 A1 11/2009 Kelleher et al.  
 2009/0299275 A1 12/2009 Gandhi et al.  
 2009/0318892 A1 12/2009 Aboytes et al.  
 2010/0004731 A1 1/2010 Gandhi et al.  
 2010/0042133 A1 2/2010 Ramzipoor et al.  
 2010/0069838 A1 3/2010 Weber et al.  
 2010/0094395 A1 4/2010 Kellett  
 2010/0106162 A1 4/2010 Jaeger et al.  
 2010/0152650 A1 6/2010 Schrodt  
 2010/0152828 A1 6/2010 Pakbaz et al.  
 2010/0160944 A1 6/2010 Teoh et al.  
 2010/0160953 A1 6/2010 Ngo et al.  
 2010/0234872 A1 9/2010 Guo et al.  
 2010/0249823 A1 9/2010 Gandhi et al.  
 2010/0256666 A1 10/2010 Chen et al.  
 2010/0268158 A1 10/2010 Porter  
 2010/0268201 A1 10/2010 Tieu et al.  
 2010/0268204 A1 10/2010 Tieu et al.  
 2010/0268252 A1 10/2010 Chen et al.

## FOREIGN PATENT DOCUMENTS

CN 101589972 A 12/2009  
 CN 20110506 A 5/2011  
 EP 0 547 530 A1 6/1993  
 EP 0 707 830 A1 4/1996  
 EP 0 719 522 A1 7/1996  
 EP 0 941 703 A1 9/1999  
 EP 0 941 704 A1 9/1999  
 EP 0 948 935 A1 10/1999  
 EP 0 992 220 A1 10/1999  
 EP 1 010 396 A1 6/2000  
 EP 1 073 377 A1 2/2001  
 EP 2 319 455 A2 5/2001  
 EP 0 842 010 B1 2/2003  
 EP 1 188 413 A3 7/2003  
 EP 0 830 873 B1 4/2004  
 EP 1 531 461 A 3/2005  
 EP 1 538 997 B1 6/2005  
 EP 1 266 629 B1 11/2006  
 EP 1 738 698 A2 1/2007  
 EP 1 791 590 A 6/2007  
 EP 1 797 832 A1 6/2007  
 EP 1 797 833 A1 6/2007  
 EP 1 621 150 B1 9/2007  
 EP 1 621 148 B1 10/2007  
 EP 1 339 328 B1 2/2008  
 EP 1 621 149 B1 2/2008  
 EP 1 889 577 A1 2/2008  
 EP 1 738 694 B1 7/2008  
 EP 1 743 600 B1 7/2008  
 EP 1 738 696 B1 8/2008  
 EP 1 255 492 B1 10/2008  
 EP 1 792 576 B1 10/2008  
 EP 1 795 133 B1 10/2008  
 EP 1 255 493 B1 11/2008  
 EP 1 738 693 B1 11/2008  
 EP 1 992 308 A2 11/2008  
 EP 1 813 196 B1 12/2008  
 EP 1 120 088 B1 4/2009  
 EP 1 825 823 B1 6/2009  
 EP 1 738 697 B1 4/2010  
 EP 1 792 575 B1 6/2010  
 EP 2 131 754 B1 6/2010  
 EP 2 231 030 A 9/2010

EP 2 234 562 A 10/2010  
 EP 1 985 240 B1 2/2011  
 EP 1 886 632 B1 4/2011  
 EP 1 813 213 B1 12/2011  
 EP 2 111 828 B1 2/2012  
 JP 52141092 A 11/1977  
 JP 56043962 A 4/1981  
 JP 01-238874 A 9/1989  
 JP 5158069 A 6/1992  
 JP 07-265431 A 10/1995  
 JP H08506033 A 7/1996  
 JP 2008-250576 A 4/1998  
 JP 2003-521991 A 7/2003  
 JP 2005-524479 A 8/2005  
 JP 2008-510594 A 4/2008  
 JP 2011-507636 A 3/2011  
 JP 2011-507638 A 3/2011  
 WO WO 91/13592 A1 9/1991  
 WO WO 94/06503 A1 3/1994  
 WO WO 94/10936 A1 5/1994  
 WO WO 95/07667 A1 3/1995  
 WO WO 95/23558 A1 9/1995  
 WO WO 95/27443 A1 10/1995  
 WO WO 96/00034 A1 1/1996  
 WO WO 96/00104 A1 1/1996  
 WO WO 97/26939 A1 7/1997  
 WO WO 97/27888 A1 8/1997  
 WO WO 98/29042 A1 7/1998  
 WO WO 98/37816 A1 9/1998  
 WO WO 98/40033 A3 9/1998  
 WO WO 99/02094 A1 1/1999  
 WO WO 99/06097 A1 2/1999  
 WO WO 99/09894 A1 3/1999  
 WO WO 99/29260 A2 6/1999  
 WO WO 99/40852 A1 8/1999  
 WO WO 99/42059 A2 8/1999  
 WO WO 99/55239 A1 11/1999  
 WO WO 00/12031 A1 3/2000  
 WO WO 00/21443 A1 4/2000  
 WO WO 00/53105 A1 9/2000  
 WO WO 00/72781 A2 12/2000  
 WO WO 01/58366 A1 8/2001  
 WO WO 02/32326 A2 4/2002  
 WO WO 03/094751 A1 11/2003  
 WO WO 2005/035020 A2 4/2005  
 WO WO 2005/077281 A1 8/2005  
 WO WO 2005/113035 A3 12/2005  
 WO WO 2006/024040 A2 3/2006  
 WO WO 2006/047748 A2 5/2006  
 WO WO 2006/069123 A1 6/2006  
 WO WO 2006/081448 A1 8/2006  
 WO WO 2006/104881 A2 10/2006  
 WO WO 2006/114325 A2 11/2006  
 WO WO 2006/130743 A1 12/2006  
 WO WO 2007/041407 A1 4/2007  
 WO WO 2007/053568 A1 5/2007  
 WO WO 2007/070788 A2 6/2007  
 WO WO 2007/070792 A2 6/2007  
 WO WO 2007/070793 A2 6/2007  
 WO WO 2007/070797 A2 6/2007  
 WO WO 2007/118015 A2 10/2007  
 WO WO 2007/121405 A2 10/2007  
 WO WO 2007/123657 A2 11/2007  
 WO WO 2008/064205 A2 5/2008  
 WO WO 2008/064206 A2 5/2008  
 WO WO 2008/064209 A1 5/2008  
 WO WO 2008/066923 A1 6/2008  
 WO WO 2008/085606 A1 7/2008  
 WO WO 2008/109394 A2 9/2008  
 WO WO 2008/115544 A2 9/2008  
 WO WO 2009/012057 A2 1/2009  
 WO WO 2009/014883 A1 1/2009  
 WO WO 2009/073398 A1 6/2009  
 WO WO 2009/082716 A1 7/2009  
 WO WO 2009/086214 A1 7/2009  
 WO WO 2009/088969 A2 7/2009  
 WO WO 2009/154844 A1 12/2009  
 WO WO 2010/030348 A1 3/2010  
 WO WO 2010/045079 A1 4/2010

(56)

**References Cited**

## FOREIGN PATENT DOCUMENTS

WO WO 2010/104955 A1 9/2010  
 WO WO 2010/117883 A1 10/2010  
 WO WO 2010/120653 A1 10/2010  
 WO WO 2010/120694 A1 10/2010  
 WO WO 2010/121037 A1 10/2010  
 WO WO 2010/121049 A1 10/2010

## OTHER PUBLICATIONS

United States Patent and Trademark Office, Final Office Action mailed Oct. 26, 2011 in U.S. Appl. No. 12/340,616, 13 pages.

United States Patent and Trademark Office, Office Action mailed Apr. 12, 2011 in U.S. Appl. No. 12/340,616, 13 pages.

United States Patent and Trademark Office, Office Action mailed Sep. 3, 2010 in U.S. Appl. No. 12/340,616, 14 pages.

WIPO, U.S. International Search Authority, International Search Report mailed Mar. 19, 2009 in International Patent Application No. PCT/US2008/087855, 2 pages.

PCT International Search Report and Written Opinion for International Patent Application No. PCT/US2008/071325, Oct. 20, 2008, 10 pages, ISA/US, Alexandria, Virginia.

United States Patent and Trademark Office, Office Action mailed Nov. 20, 2008 in U.S. Appl. No. 12/275,126, 11 pages.

Canadian Intellectual Property Office, Notice of Allowance dated Nov. 28, 2007 in Canadian Patent Application No. CA2425544, 1 page.

Canadian Intellectual Property Office, Examiner's Report dated Feb. 19, 2007 in Canadian Patent Application No. CA2425544, 2 pages.

Canadian Intellectual Property Office, Examiner's Report dated Sep. 29, 2005 in Canadian Patent Application No. CA2325544, 4 pages.

IP Australia, Examination Report dated Jun. 27, 2005 in Australian Patent Application No. AU2002214623, 3 pages.

United States Patent and Trademark Office, Notice of Allowance mailed Oct. 2, 2003 in U.S. Appl. No. 10/143,724, 11 pages.

WIPO, U.S. International Search Authority, International Search Report mailed May 28, 2002 in International Patent Application No. PCT/US2001/032588, 5 pages.

Graves, V.B. et al., "Endovascular Occlusion of the Carotid or Vertebral Artery with Temporary Proximal Flow Arrest and Microcoils: Clinical Results," *AJNR Am J Neuroradiol*, vol. 18, American Society of Neuroradiology, Aug. 1997, 6 pages.

Schmutz, F. et al., "Embolization of Cerebral Arteriovenous Malformations with Silk: Histopathologic Changes and Hemorrhagic Complications," *AJNR Am J Neuroradiol*, vol. 18, American Society of Neuroradiology, Aug. 1997, 5 pages.

Rosenthal M.D., D. et al., "Endovascular infrainguinal in situ saphenous vein bypass: A multicenter preliminary report," *J. Vasc Surg* Sep. 1992, vol. 3, No. 16, pp. 453-458, 6 pages.

Rosenthal, D. et al., "Angioscope-assisted endovascular occlusion of venous tributaries: preclinical studies," *Cardiovasc Surg* Jun. 1993, vol. 1, No. 3, pp. 225-227, 3 pages.

Vinuela M.D., F. et al., "Guglielmi detachable coil embolization of acute intracranial aneurysm: perioperative anatomical and clinical outcome in 403 patients," *J. Neurosurg*, vol. 86, Mar. 1997, 8 pages.

\* cited by examiner

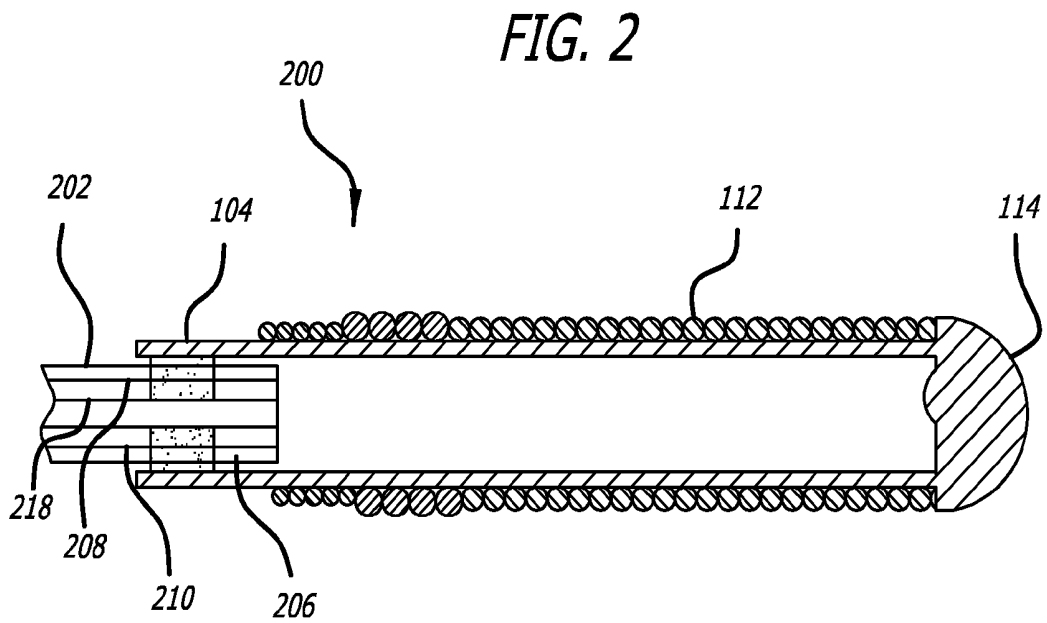
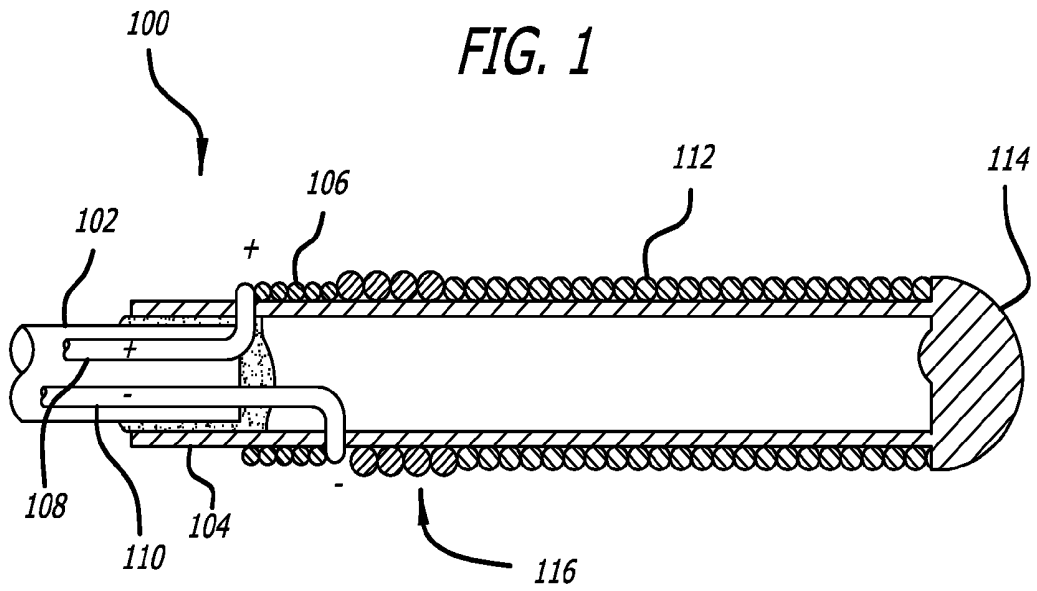

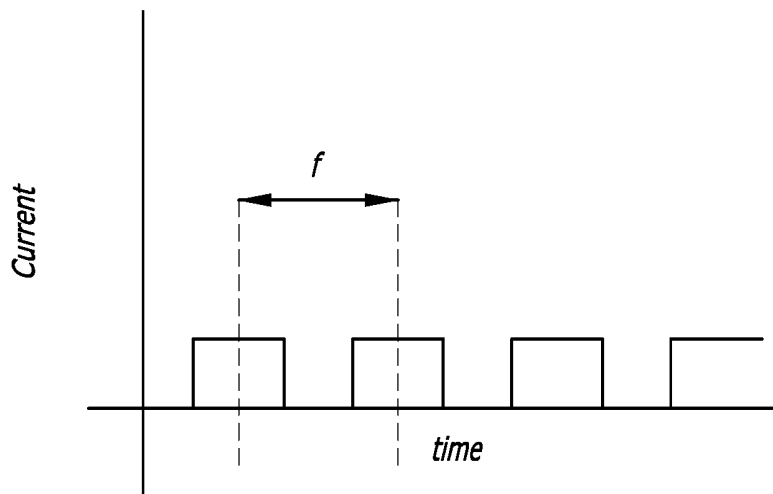

*Direct Current (DC)  
Signaling*

**FIG. 3A**

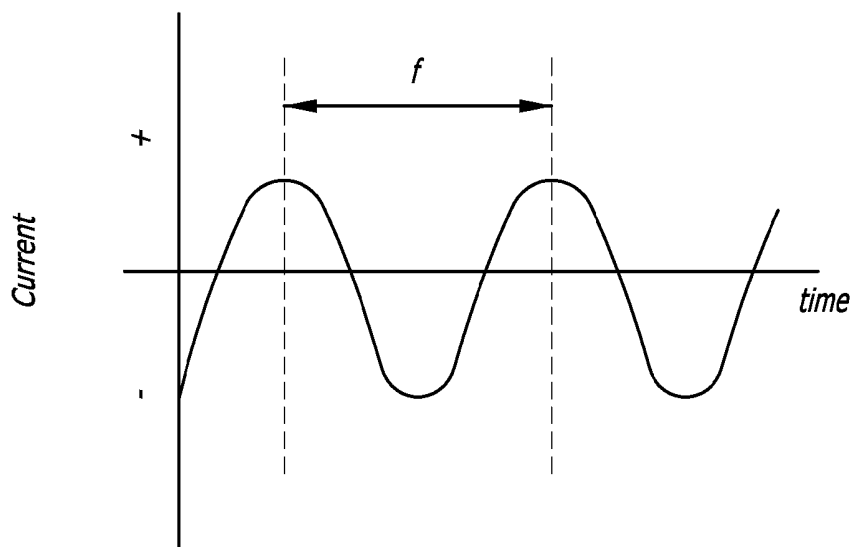

*Alternating Current (AC)  
Signaling*

**FIG. 3B**

FIG. 4

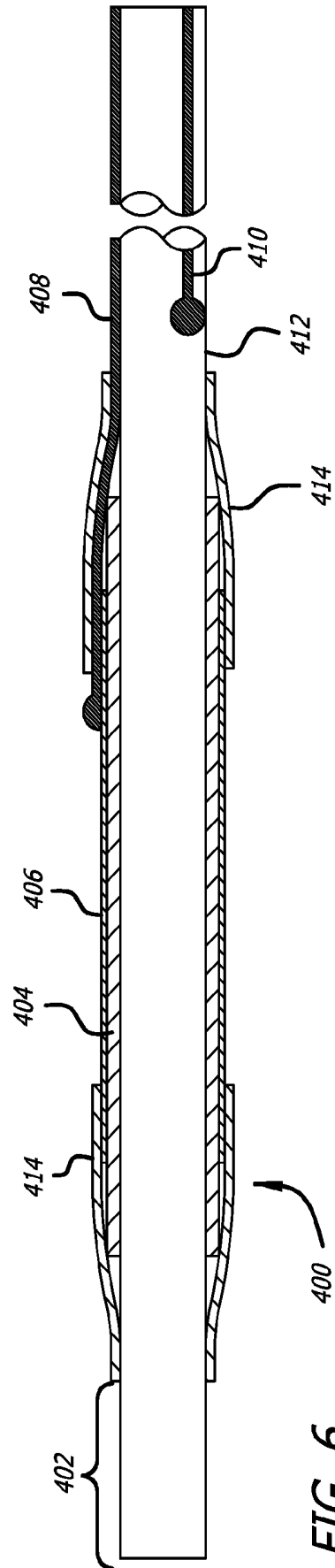
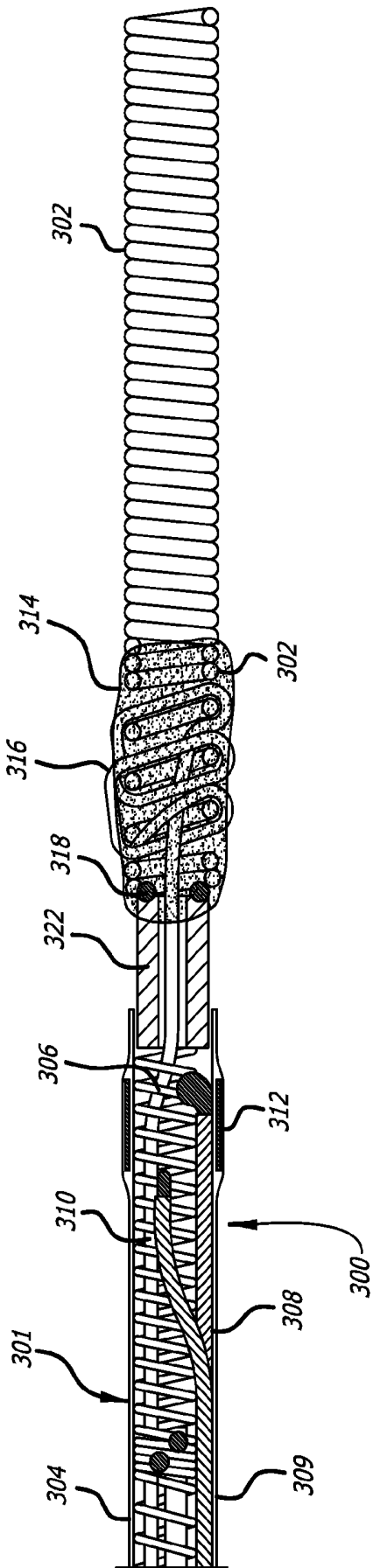
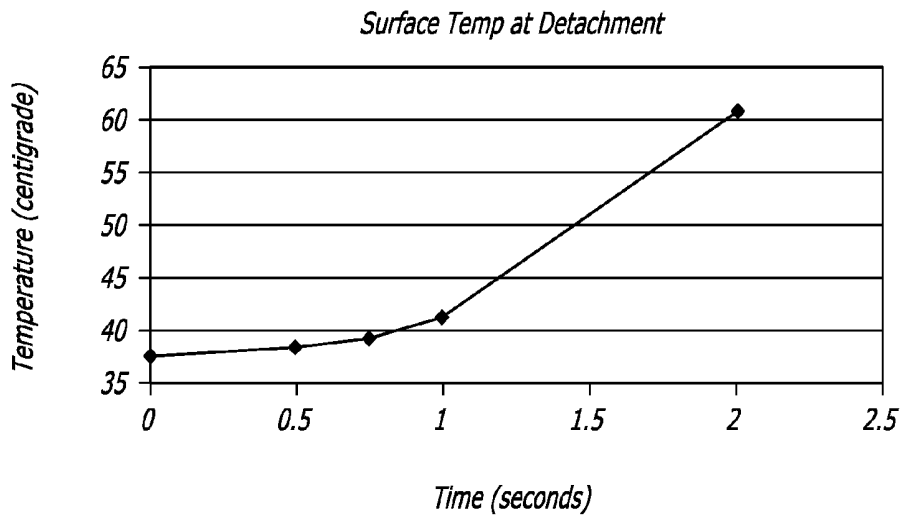
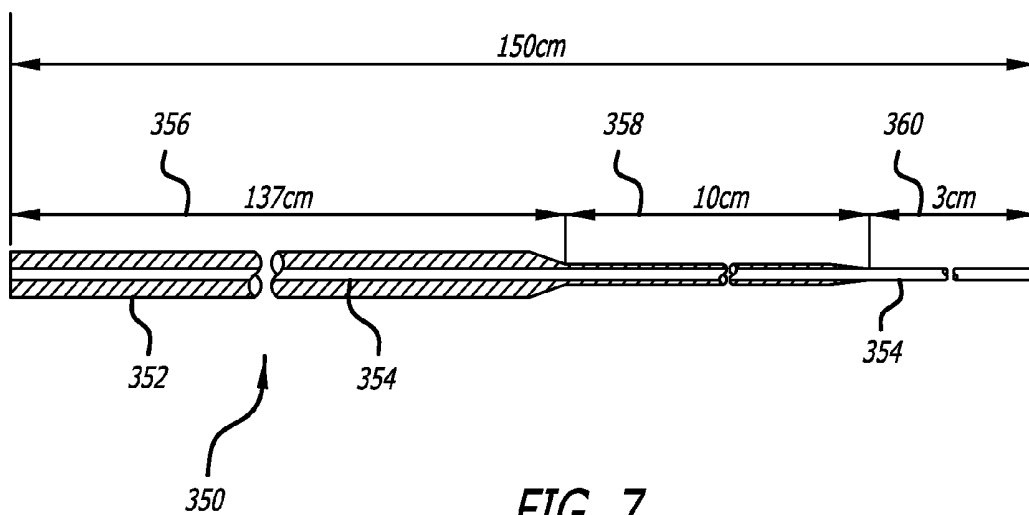

FIG. 6



**FIG. 5**



**FIG. 7**

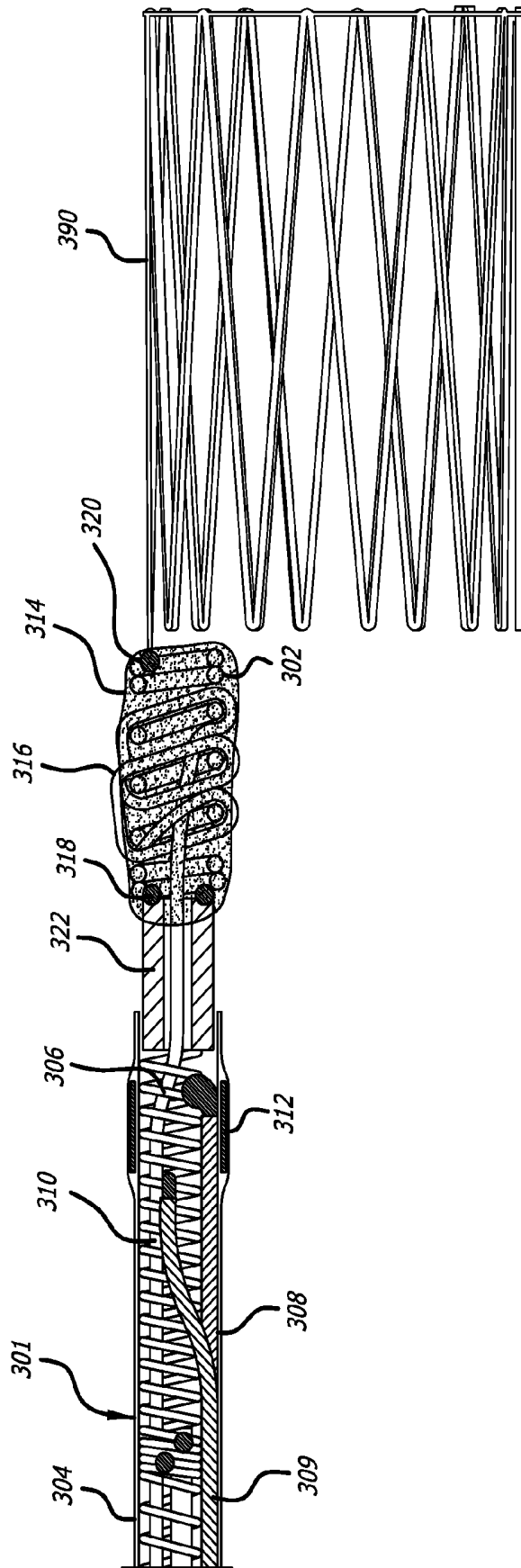
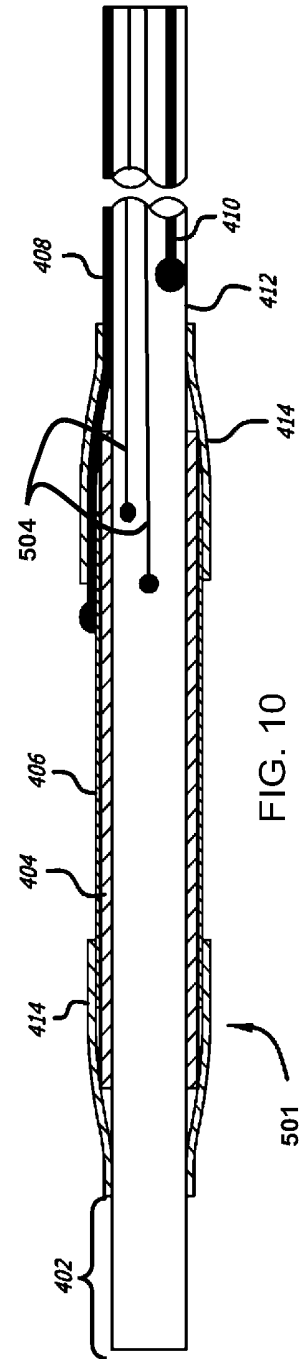
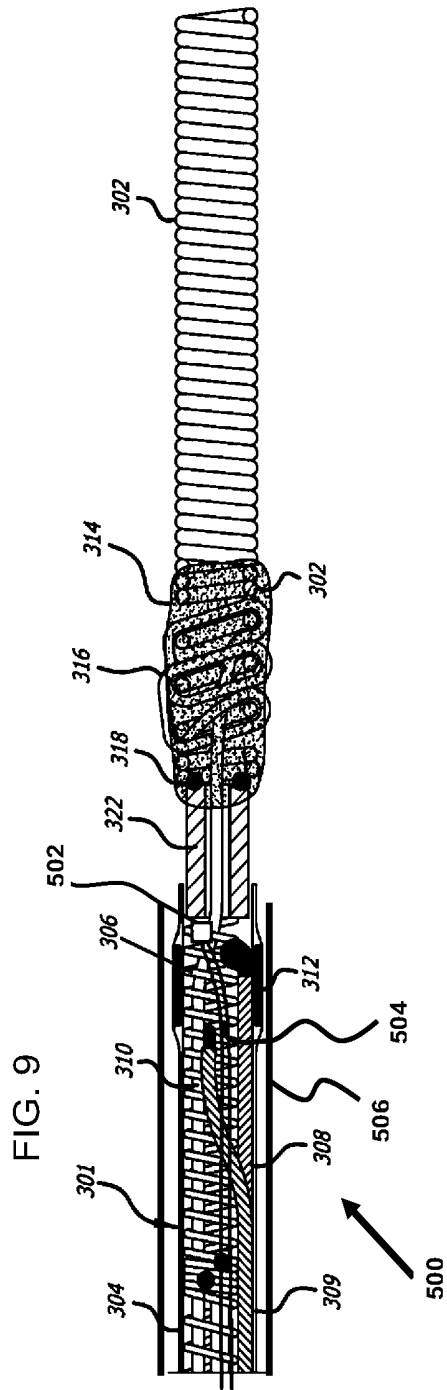

FIG. 8



## SYSTEM AND METHOD FOR LOCATING DETACHMENT ZONE OF A DETACHABLE IMPLANT

### RELATED APPLICATIONS

The present application claims priority from U.S. Provisional Application Ser. No. 61/016,154, filed Dec. 21, 2007 entitled System and Method for Locating Detachment Zone of a Detachable Implant, herein incorporated by reference in its entirety. This application also incorporates by reference U.S. Provisional Application Ser. No. 60/604,671, filed Aug. 25, 2004 entitled Thermal Detachment System For Implantable Devices; U.S. Provisional Application Ser. No. 60/685,342 filed May 27, 2005 entitled Thermal Detachment System For Implantable Devices; U.S. patent application Ser. No. 11/212,830 filed Aug. 25, 2005 entitled Thermal Detachment System For Implantable Devices; U.S. Provisional Application Ser. No. 61/016,180, filed Dec. 21, 2007 entitled Method of Detecting Implant Detachment.

### FIELD OF THE INVENTION

The present invention relates to systems and methods for delivering implant devices to a target site within the body of a patient. The present invention also relates to systems and methods for detecting a location of a detachment zone of a delivered implant device.

### BACKGROUND OF THE INVENTION

Delivery of implantable therapeutic devices by less invasive means has been demonstrated to be desirable in numerous clinical situations. For example, vascular embolization has been used to control vascular bleeding, to occlude the blood supply to tumors, to occlude fallopian tubes, and to occlude vascular aneurysms, particularly intracranial aneurysms. In recent years, vascular embolization for the treatment of aneurysms has received much attention. As another example, the use of mesh or scaffold devices such as stents to open blocked vessels or to retain embolic coils have also received much attention.

Several different treatment modalities have been employed in the prior art for deploying implant devices. For example, numerous repositionable detachment systems for implant devices have been described in the prior art including U.S. Pat. No. 5,895,385 to Guglielmi et al. and U.S. Pat. No. 5,108,407 to Geremia et al., the contents of which are hereby incorporated by reference. Several systems, such as those disclosed in U.S. Pat. No. 6,500,149 to Gandhi et al. and U.S. Pat. No. 4,346,712 to Handa et al., the contents of which are hereby incorporated by reference, describe the use of a heater to detach and deploy the implant device.

Some percutaneously delivered detachable implant systems, such as those used to deliver occlusive coils to aneurysms, include a detachable implant that is temporarily attached to a pusher mechanism within a microcatheter. The pusher mechanism is used to advance the implant out of the distal end of the microcatheter. Once the implant has been advanced to a desired location relative to the microcatheter, referred to herein as a detachment zone, a detachment mechanism is employed to detach the implant from the pusher. It is important not to detach the implant prior to reaching the detachment zone as the implant may get hung up in the end of the catheter and subsequently get deployed at an undesirable location in the body.

Typically, in order to determine whether the implant has been advanced to the detachment zone relative to the microcatheter, radiopaque markers are used on both the microcatheter and either the pusher, the implant, or both. Thus, an operator uses the radiopaque markers to monitor the relative positions of the microcatheter and the implant as the implant is being advanced with the pusher. Monitoring the positions of the radiopaque markers requires the use of an x-ray device during the procedure. Using an x-ray imaging machine adds expense, complicates the procedure, and adds another space-consuming machine to the area surrounding the patient. Additionally, due to the coiled nature of the implant, the view of the radiopaque markers can become blocked by the coil.

### SUMMARY OF THE INVENTION

The present invention is an implant delivery and detachment system used to position and deploy implantable devices such as coils, stents, filters, and the like within a body cavity including, but not limited to, blood vessels, fallopian tubes, malformations such as fistula and aneurysms, heart defects (e.g. left atrial appendages and sepal openings), and other luminal organs.

The system comprises an implant, a delivery catheter (generically referred to as the pusher or delivery pusher), a detachable joint for coupling the implant to the pusher, a heat generating apparatus (generically referred to as the heater), and a power source to apply energy to the heater.

In one aspect of the present invention, the implant is coupled to the pusher using a tether, string, thread, wire, filament, fiber, or the like. Generically this is referred to as the tether. The tether may be in the form of a monofilament, rod, ribbon, hollow tube, or the like. Many materials can be used to detachably join the implant to the pusher. One class of materials are polymers such as polyolefin, polyolefin elastomer such as those made by Dow marketed under the trade name Engage or Exxon marketed under the trade name Affinity, polyethylene, polyester (PET), polyamide (Nylon), polyurethane, polypropylene, block copolymer such as PEBAX or Hytrel, and ethylene vinyl alcohol (EVA); or rubbery materials such as silicone, latex, and Kraton. In some cases, the polymer may also be cross-linked with radiation to manipulate its tensile strength and melt temperature. Another class of materials is metals such as nickel titanium alloy (Nitinol), gold, and steel. The selection of the material depends on the capacity of the material to store potential energy, the melting or softening temperature, the power used for detachment, and the body treatment site. The tether may be joined to the implant and/or the pusher by welding, knot tying, soldering, adhesive bonding, or other means known in the art. In one embodiment where the implant is a coil, the tether may run through the inside lumen of the coil and be attached to the distal end of the coil. This design not only joins the implant to the pusher, but also imparts stretch resistance to the coil without the use of a secondary stretch resistant member. In other embodiments where the implant is a coil, stent, or filter; the tether is attached to the proximal end of the implant.

In another aspect of the present invention, the tether detachably coupling the implant to the pusher acts as a reservoir of stored (i.e. potential) energy that is released during detachment. This advantageously lowers the time and energy required to detach the implant because it allows the tether to be severed by application of heat without necessarily fully melting the material. The stored energy also may exert a force on the implant that pushes it away from the delivery catheter. This separation tends to make the system more reliable because it may prevent the tether from re-solidifying and

holding the implant after detachment. Stored energy may be imparted in several ways. In one embodiment, a spring is disposed between the implant and pusher. The spring is compressed when the implant is attached to the pusher by joining one end of the tether to one of either the pusher or implant, pulling the free end of the tether until the spring is at least partially compressed, then affixing the free end of the tether to the other of the implant or the pusher. Since both ends of the tether are restrained, potential energy in the form of tension on the tether (or compression in the spring) is stored within the system. In another embodiment, one end of the tether is fixed as in the previous embodiment, and then the tether is placed in tension by pulling on the free end of the tether with a pre-determined force or displacement. When the free end of the tether is then affixed, the elongation (i.e. elastic deformation) of the tether material itself stores energy.

In another aspect of the present invention, a heater is disposed on or within the pusher, typically, but not necessarily, near the distal end of the pusher. The heater may be attached to the pusher by, for example, soldering, welding, adhesive bonding, mechanical bonding, or other techniques known in the art. The heater may be in the form of a wound coil, heat pipe, hollow tube, band, hypotube, solid bar, toroid, or similar shape. The heater may be made from a variety of materials such as steel, chromium cobalt alloy, platinum, silver, gold, tantalum, tungsten, manganin, chromium nickel alloy available from California Fine Wire Company under the trade name Stable Ohm, conductive polymer, or the like. The tether is disposed in proximity to the heater. The tether may pass through the lumen of a hollow or coil-type heater or may be wrapped around the heater. Although the tether may be disposed in direct contact with the heater, this is not necessary. For ease of assembly, the tether may be disposed in proximity to, but not actually touching, the heater.

The delivery catheter or pusher is an elongate member with distal and proximal ends adapted to allow the implant to be maneuvered to the treatment site. The pusher comprises a core mandrel and one or more electrical leads to supply power to the heater. The pusher may taper in dimension and/or stiffness along the length, with the distal end usually being more flexible than the proximal end. In one embodiment, the pusher is adapted to be telescopically disposed within a delivery conduit such as a guide catheter or microcatheter. In another embodiment, the pusher contains an inner lumen allowing it to be maneuvered over a guide wire. In still another embodiment, the pusher can be maneuvered directly to the treatment site without a secondary device. The pusher may have a radiopaque marking system visible with fluoroscopy that allows it to be used in conjunction with radiopaque markings on the microcatheter or other adjunctive devices.

In another aspect of the present invention, the core mandrel is in the form of a solid or hollow shaft, wire, tube, hypotube, coil, ribbon, or combination thereof. The core mandrel may be made from plastic materials such as PEEK, acrylic, polyamide, polyimide, Teflon, acrylic, polyester, block copolymer such as PEBAX, or the like. The plastic member(s) may be selectively stiffened along the length with reinforcing fibers or wires made from metal, glass, carbon fiber, braid, coils, or the like. Alternatively, or in combination with plastic components, metallic materials such as stainless steel, tungsten, chromium cobalt alloy, silver, copper, gold, platinum, titanium, nickel titanium alloy (Nitinol), and the like may be used to form the core mandrel. Alternatively, or in combination with plastic and/or metallic components, ceramic components such as glass, optical fiber, zirconium, or the like may be used to form the core mandrel. The core mandrel may also be a composite of materials. In one embodiment, the core man-

drel comprises an inner core of radiopaque material such as platinum or tantalum and an outer covering of kink-resistant material such as steel or chromium cobalt. By selectively varying the thickness of the inner core, radiopaque identifiers can be provided on the pusher without using secondary markers. In another embodiment, a core material, for example stainless steel, with desirable material properties such as kink resistance and/or compressive strength is selectively covered (by, for example, plating, drawing, or similar methods known in the art) with a low electrical resistance material such as copper, aluminum, gold, or silver to enhance its electrical conductivity, thus allowing the core mandrel to be used as an electrical conductor. In another embodiment, a core material, for example, glass or optical fiber, with desirable properties such as compatibility with Magnetic Resonance Imaging (MRI), is covered with a plastic material such as PEBAX or polyimide to prevent the glass from fracturing or kinking.

In another aspect of the present invention, the heater is attached to the pusher, and then one or more electrical conductors are attached to the heater. In one embodiment a two of conductive wires run substantially the length of the pusher and are coupled to the heater near the distal end of the pusher and to electrical connectors near the proximal end of the pusher. In another embodiment, one conductive wire runs the substantially the length of the pusher and the core mandrel itself is made from a conductive material or coated with a conductive material to act as a second electrical lead. The wire and the mandrel are coupled to the heater near the distal end and to one or more connectors near the proximal end of the pusher. In another embodiment, a bipolar conductor is coupled to the heater and is used in conjunction with radiofrequency (RF) energy to power the heater. In any of the embodiments, the conductor(s) may run in parallel to the core mandrel or may pass through the inner lumen of a substantially hollow core mandrel (for example, a hypotube).

In another aspect of the present invention, an electrical and/or thermally insulating cover or sleeve may be placed over the heater. The sleeve may be made from insulating materials such as polyester (PET), Teflon, block copolymer, silicone, polyimide, polyamide, and the like.

In another aspect of the present invention, electrical connector(s) are disposed near the proximal end of the pusher so that the heater can be electrically connected to a power source through the conductors. In one embodiment, the connectors are in the form of a plug with one or more male or female pins. In another embodiment, the connector(s) are tubes, pins, or foil that can be connected with clip-type connectors. In another embodiment, the connector(s) are tubes, pins, or foil that are adapted to mate with an external power supply.

In another aspect of the present invention, the pusher connects to an external power source so that the heater is electrically coupled to the power source. The power source may be from battery(s) or connected to the electrical grid by a wall outlet. The power source supplies current in the form of direct current (DC), alternating current (AC), modulated direct current, or radiofrequency (RF) at either high or low frequency. The power source may be a control box that operates outside of the sterile field or may be a hand-held device adapted to operate within a sterile field. The power source may be disposable, rechargeable, or may be reusable with disposable or rechargeable battery(s).

In another aspect of the present invention, the power source may comprise an electronic circuit that assists the user with detachment. In one embodiment, the circuit detects detachment of the implant and provides a signal to the user when detachment has occurred. In another embodiment, the circuit comprises a timer that provides a signal to the user when a

pre-set length of time has elapsed. In another embodiment, the circuit monitors the number of detachments and provides a signal or performs an operation such as locking the system off when a pre-set number of detachments have been performed. In another embodiment, the circuit comprises a feedback loop that monitors the number of detachment attempts and increases the current, voltage, and/or detachment time in order to increase the likelihood of a successful detachment.

In another aspect of the present invention, the construction of the system allows for extremely short detachment time. In one embodiment the detachment time is less than 1 second.

In another aspect of the present invention, the construction of the system minimizes the surface temperature of the device during detachment. In one embodiment, the surface temperature at the heater during detachment is under 50° C. In another embodiment, the surface temperature at the heater during detachment is under 42° C.

The present invention is also a method and system for detecting the location of the detachment zone of a detachable coil as it exits the distal tip of the microcatheter without using radiopaque markers. Various sensing techniques are used to detect a change in various corresponding parameters due to the environmental difference between the inside of the microcatheter and exposure to a target site in the body.

In another aspect of the present invention a temperature sensor is utilized to detect a change in temperature as the sensor exits the microcatheter. The change in temperatures indicates that the detachable implant is in a desired detachment zone.

In another aspect of the present invention a pressure sensor is utilized to detect a change in pressure as the sensor exits the microcatheter. The change in pressure indicates that the detachable implant is in a desired detachment zone.

In another aspect of the present invention an ultrasound sensor is utilized to detect a change in environmental space as the sensor exits the microcatheter. When inside the microcatheter, the ultrasonic sensor detects the distance to the inner walls of the microcatheter. When outside the microcatheter, the ultrasonic sensor detects the increased distance to the inner walls of the vascular lumen or aneurysm. Hence, the change in distance indicates that the detachable implant is in a desired detachment zone.

Yet another aspect of the present invention the detachable coil is utilized as a detection mechanism. During navigation to the target site, the coil is contained, in a straight configuration, within the microcatheter. As the coil is pushed out of the microcatheter, it regains a curved configuration. If an electrical current is passed through the coil, the resistance to current flow through the coil changes as it curves. This change in resistance is used as a detection mechanism.

These and other aspects and features of the present invention will be appreciated upon consideration of the following drawings and detailed descriptions.

#### BRIEF DESCRIPTION OF THE DRAWINGS

FIG. 1 illustrates a cross-sectional side view of a first embodiment of a detachment system according to the present invention;

FIG. 2 illustrates a cross-sectional side view of a second embodiment of a detachment system according to the present invention;

FIG. 3A illustrates example direct signaling current according to the present invention;

FIG. 3B illustrates example alternating signaling current according to the present invention;

FIG. 4 illustrates a cross-sectional side view of a third embodiment of a detachment system according to the present invention;

FIG. 5 illustrates example temperature data of the surface of a detachment system as a function of time according to the present invention;

FIG. 6 illustrates a cross-sectional side view of an electrical connector of a detachment system according to the present invention;

FIG. 7 illustrates a cross-sectional side view of radiopaque layers of a detachment system according to the present invention; and

FIG. 8 illustrates a cross-sectional side view of a detachment system including a stent according to the present invention;

FIG. 9 illustrates a partially exploded perspective view of a delivery system according to the present invention;

FIG. 10 illustrates a cross-sectional side view of an electrical connector of a detachment system according to the present invention.

#### DETAILED DESCRIPTION OF THE INVENTION

Turning to FIG. 1, a detachment system **100** of the present invention, and specifically the distal portion of the detachment system **100**, is illustrated. The detachment system **100** includes a pusher **102** that is preferably flexible. The pusher **102** is configured for use in advancing an implant device **112** into and within the body of a patient and, specifically, into a target cavity site for implantation and delivery of the implant device **112**. Potential target cavity sites include but are not limited to blood vessels and vascular sites, such as, e.g., aneurysms and fistula, heart openings and defects, such as, e.g., the left atrial appendage, and other luminal organs, such as, e.g., fallopian tubes.

A stretch-resistant tether **104** detachably couples the implant **112** to the pusher **102**. In this example, the tether **104** is a plastic tube that is bonded to the pusher **102**. A substantially solid cylinder could also be a design choice for the tether **104**. The stretch resistant tether **104** extends at least partially through the interior lumen of an implant device **112**.

Near the distal end of the pusher **102**, a heater **106** is disposed in proximity to the stretch resistant tether **104**. The heater **106** may be wrapped around the stretch resistant tether **104** such that the heater **106** is exposed to or otherwise in direct contact with the blood or the environment, or alternatively may be insulated by a sleeve, jacket, epoxy, adhesive, or the like. The pusher **102** comprises a pair of electrical wires, positive electrical wire **108** and negative electrical wire **110**. The wires **108** and **110** are coupled to the heater **106** by any suitable means, such as, e.g., by welding or soldering.

The electrical wires **108**, **110** are capable of being coupled to a source of electrical power (not shown). As illustrated the negative electrical wire **110** is coupled to the distal end of the heater **106** and the positive electrical wire **108** is coupled to the proximal end of the heater **106**. In another embodiment, this configuration may be reversed, i.e., the negative electrical wire **110** is coupled to the proximal end of the heater **106** while the positive electrical wire **108** is coupled to the distal end of the heater **106**.

Energy is applied to the heater **106** from the electrical wires **108**, **110** in order to sever the portion of the tether **104** in the proximity of the heater **106**. It is not necessary for the heater **106** to be in direct contact with the tether **104**. The heater **106** merely should be in sufficient proximity to the tether **104** so that heat generated by the heater **106** causes the tether **104** to sever. As a result of activating the heater **106**, the section of

the stretch resistant tether **104** that is approximately distal from the heater **106** and within the lumen of an implant device **112** is released from the pusher **102** along with the implant device **112**.

As illustrated, the implant device **112** is an embolic coil. An embolic coil suitable for use as the implant device **112** may comprise a suitable length of wire formed into a helical microcoil. The coil may be formed from a biocompatible material including platinum, rhodium, palladium, rhenium, tungsten, gold, silver, tantalum, and various alloys of these metals, as well as various surgical grade stainless steels. Specific materials include the platinum/tungsten alloy known as Platinum 479 (92% Pt, 8% W, available from Sigmund Cohn, of Mount Vernon, N.Y.) and nickel/titanium alloys (such as the nickel/titanium alloy known as Nitinol).

Another material that may be advantageous for forming the coil is a bimetallic wire comprising a highly elastic metal with a highly radiopaque metal. Such a bimetallic wire would also be resistant to permanent deformation. An example of such a bimetallic wire is a product comprising a Nitinol outer layer and an inner core of pure reference grade platinum, available from Sigmund Cohn, of Mount Vernon, N.Y., and Anomet Products, of Shrewsbury, Mass.

Commonly-assigned U.S. Pat. No. 6,605,101 provides a further description of embolic coils suitable for use as the implant device **112**, including coils with primary and secondary configurations wherein the secondary configuration minimizes the degree of undesired compaction of the coil after deployment. The disclosure of U.S. Pat. No. 6,605,101 is fully incorporated herein by reference. Furthermore, the implant device **112** may optionally be coated or covered with a hydrogel or a bioactive coating known in the art.

The coil-type implant device **112** resists unwinding because the stretch resistant tether **104** that extends through the lumen of the implant device **112** requires substantially more force to plastically deform than the implant device **112** itself. The stretch resistant tether **104** therefore assists in preventing the implant device **112** from unwinding in situations in which the implant device **112** would otherwise unwind.

During assembly, potential energy may be stored within the device to facilitate detachment. In one embodiment, an optional spring **116** is placed between the heater **106** and the implant device **112**. The spring is compressed during assembly and the distal end of the tether **104** may be tied or coupled to the distal end of the implant device **112**, or may be melted or otherwise formed into an atraumatic distal end **114**.

In one embodiment, the stretch resistant tether **104** is made from a material such as a polyolefin elastomer, polyethylene, or polypropylene. One end of the tether **104** is attached to the pusher **102** and the free end of the tether **104** is pulled through the implant **112** with the proximal end of the implant **112** flush to either the heater **106** (if no spring **116** is present) or to the compressed spring **116**. A pre-set force or displacement is used to pre-tension the tether **104**, thus storing energy in an axial orientation (i.e. co-linear or parallel to the long axis of the pusher **102**) within the tether **104**. The force or displacement depends on the tether material properties, the length of the tether **104** (which itself depends on the tether's attachment point on the pusher and the length of the implant). Generally, the force is below the elastic limit of the tether material, but sufficient to cause the tether to sever quickly when heat is applied. In one preferred embodiment wherein the implant to be deployed is a cerebral coil, the tether has a diameter within the range of approximately 0.001 to 0.007

inches. Of course the size of the tether can be changed to accommodate different types and sizes of other implants as necessary.

Turning to FIG. 2, another embodiment of a detachment system of the present invention, detachment system **200**, is illustrated. Detachment system **200** shares several common elements with detachment system **100**. For example, the same devices usable as the implant device **112** with detachment system **100** are also usable as the implant device **112** with detachment system **200**. These include, e.g., various embolic microcoils and coils. The implant device **112** has been previously described with respect to detachment system **100**. As with the implant device **112**, the same identification numbers are used to identify other elements/components of detachment system **100** that may correspond to elements/components of detachment system **200**. Reference is made to the description of these elements in the description of detachment system **100** as that description also applies to these common elements in detachment system **200**.

With detachment system **200**, an interior heating element **206** is used to separate a section of a stretch resistant tube **104** and an associated implant device **112** from the detachment system **200**. Detachment system **200** includes a delivery pusher **202** that incorporates a core mandrel **218**. The detachment system **200** further includes a positive electrical wire **208** and a negative electrical wire **210** that extend through the lumen of the delivery pusher **202**.

To form the internal heating element **206**, the positive electrical wire **208** and the negative electrical wire **210** may be coupled to the core mandrel **218** of the delivery pusher **202**. Preferably, the electrical wires **208**, **210** are coupled to a distal portion of the core mandrel **218**.

In one embodiment, the positive electrical wire **208** is coupled to a first distal location on the core wire **218**, and the negative electrical wire **210** is coupled to a second distal location on the core wire **218**, with the second distal location being proximal to the first distal location. In another embodiment, the configuration is reversed, i.e., the positive electrical wire **208** is coupled to the second distal location and the negative electrical wire **210** is coupled to the first distal location on the core wire **218**. When the positive electrical wire **208** and the negative electrical wire **210** are coupled to the distal portion of the core mandrel **218**, the distal portion of the core mandrel **218** along with the electrical wires **208**, **210** forms a circuit that is the interior heating element **206**.

The heater **206** increases in temperature when a current is applied from a power source (not shown) that is coupled to the positive electrical wire **208** and the negative electrical wire **210**. If a greater increase in temperature/higher degree of heat is required or desired, a relatively high resistance material such as platinum or tungsten may be coupled to the distal end of the core mandrel **218** to increase the resistance of the core mandrel **218**. As a result, higher temperature increases are produced when a current is applied to the heater **206** than would be produced with a lower resistance material. The additional relatively high resistance material coupled to the distal end of the core mandrel **218** may take any suitable form, such as, e.g., a solid wire, a coil, or any other shape or material as described above.

Because the heater **206** is located within the lumen of the tube-shaped tether **104**, the heater **206** is insulated from the body of the patient. As a result, the possibility of inadvertent damage to the surrounding body tissue due to the heating of the heater **206** may be reduced.

When a current is applied to the heater **206** formed by the core mandrel **218**, the positive electrical wire **208**, and the negative electrical wire **210**, the heater **206** increases in tem-

perature. As a result, the portion of the stretch resistant tether **104** in proximity to the heater **206** severs and is detached, along with the implant device **112** that is coupled to the tether **104**, from the detachment system **200**.

In one embodiment of the detachment system **200**, the proximal end of the stretch resistant tether **104** (or the distal end of a larger tube (not shown) coupled to the proximal end of the stretch resistant tether **104**) may be flared in order to address size constraints and facilitate the assembly of the detachment system **200**.

In a similar manner as with detachment system **100**, energy may be stored within the system with, for example, an optional compressive spring **116** or by pre-tensioning the tether **104** during assembly as previously described. When present, the release of potential energy stored in the system operates to apply additional pressure to separate the implant device **112**, and the portion of the stretch resistant tether **104** to which the implant device **112** is coupled, away from the heater **206** when the implant device **112** is deployed. This advantageously lowers the required detachment time and temperature by causing the tether **104** to sever and break.

As with detachment system **100**, the distal end of the stretch resistant tether **104** of detachment system **200** may be tied or coupled to the distal end of the implant device **112**, or may be melted or otherwise formed into an atraumatic distal end **114**.

FIG. 4 illustrates another preferred embodiment of a detachment system **300**. In many respects, the detachment system **300** is similar to the detachment system **200** shown in FIG. 2 and detachment system **100** shown in FIG. 1. For example, the detachment system **300** includes a delivery pusher **301** containing a heater **306** that detaches an implant device **302**. Detachment system **300** also utilizes a tether **310** to couple the implant device **302** to the delivery pusher **301**.

In the cross-sectional view of FIG. 4, a distal end of the delivery pusher **301** is seen to have a coil-shaped heater **306** that is electrically coupled to electrical wires **308** and **309**. These wires **308**, **309** are disposed within the delivery pusher **301**, exiting at a proximal end of the delivery pusher **301** and coupling to a power supply (not shown). The tether **310** is disposed in proximity to the heater **306**, having a proximal end fixed within the delivery pusher **301** and a distal end coupled to the implant device **302**. As current is applied through wires **308** and **309**, the heater **306** increases in temperature until the tether **310** breaks, releasing the implant device **302**.

To reduce the transfer of heat from the heater **306** to the surrounding tissue of the patient and to provide electrical insulation, an insulating cover **304** is included around at least the distal end of the outer surface of the delivery pusher **301**. As the thickness of the cover **304** increases, the thermal insulating properties also increase. However, increased thickness also brings increased stiffness and a greater diameter to the delivery pusher **301** that could increase the difficulty of performing a delivery procedure. Thus, the cover **304** is designed with a thickness that provides sufficient thermal insulating properties without overly increasing its stiffness.

To enhance attachment of the tether **310** to the implant device **302**, the implant device **302** may include a collar member **322** welded to the implant device **302** at weld **318** and sized to fit within the outer reinforced circumference **312** of the delivery pusher **301**. The tether **310** ties around the proximal end of the implant device **302** to form knot **316**. Further reinforcement is provided by an adhesive **314** that is disposed around the knot **316** to prevent untying or otherwise unwanted decoupling.

In a similar manner as with detachment systems **100** and **200**, energy may be stored within the system with, for example, an optional compressive spring (similar to compressive spring **116** in FIG. 1 but not shown in FIG. 4) or by axially pre-tensioning the tether **104** during assembly. In this embodiment, one end of the tether **310** is attached near the proximal end of the implant device **302** as previously described. The free end of the tether **310** is threaded through a distal portion of the delivery pusher **301** until it reaches an exit point (not shown) of the delivery pusher **301**. Tension is applied to the tether **310** in order to store energy in the form of elastic deformation within the tether material by, for example, placing a pre-determined force on the free end of the tether **310** or moving the taunt tether **310** a pre-determined displacement. The free end of the tether **310** is then joined to the delivery pusher **301** by, for example, tying a knot, applying adhesive, or similar methods known in the art.

When present, the release of potential energy stored in the system operates to apply additional pressure to separate the implant device **302**, and the portion of the tether **310** to which the implant device **302** is coupled, away from the heater **306** when the implant device **302** is deployed. This advantageously lowers the required detachment time and temperature by causing the tether **310** to sever and break.

The present invention also provides for methods of using detachment systems such as detachment systems **100**, **200**, or **300**. The following example relates to the use of detachment system **100**, **200**, or **300** for occluding cerebral aneurysms. It will, however, be appreciated that modifying the dimensions of the detachment system **100**, **200**, or **300** and the component parts thereof and/or modifying the implant device **112**, **302** configuration will allow the detachment system **100**, **200**, or **300** to be used to treat a variety of other malformations within a body.

With this particular example, the delivery pusher **102**, **202**, or **301** of the detachment system **100**, **200**, or **300** may be approximately 0.010 inches to 0.030 inches in diameter. The tether **104**, **310** that is coupled near the distal end of the delivery pusher **102**, **202**, or **301** and is coupled the implant device **112**, **302** may be 0.0002 inches to 0.020 inches in diameter. The implant device **112**, **302**; which may be a coil, may be approximately 0.005 inches to 0.020 inches in diameter and may be wound from 0.0005 inch to 0.005 inch wire.

If potential energy is stored within the detachment system **100**, **200**, or **300**, the force used to separate the implant **112**, **302** from the pusher typically ranges up to 250 grams force.

The delivery pusher **102**, **202**, or **301** may comprise a core mandrel **218** and at least one electrically conductive wire **108**, **110**, **208**, **210**, **308**, or **309**. The core mandrel **218** may be used as an electrical conductor, or a pair of conductive wires may be used, or a bipolar wire may be used as previously described.

Although the detachment systems **100**, **200**, and **300** have been illustrated as delivering a coil, other implant devices are contemplated in the present invention. For example, FIG. 8 illustrates the detachment system **300** as previously described in FIG. 4 having an implant that is a stent **390**. This stent **390** could similarly be detached by a similar method as previously described in regards to the detachment systems **100**, **200**, and **300**. In a further example, the detachment systems **100**, **200**, or **300** may be used to deliver a filter, mesh, scaffolding or other medical implant suitable for delivery within a patient.

FIG. 7 presents an embodiment of a delivery pusher **350**, which could be used in any of the embodiments as delivery pusher **102**, **202**, or **301**, which includes radiopaque materials to communicate the position of the delivery pusher **350** to the user. Specifically, the radiopaque marker material is inte-

grated into the delivery pusher **350** and varied in thickness at a desired location, facilitating easier and more precise manufacturing of the final delivery pusher **350**.

Prior delivery pusher designs, such as those seen in U.S. Pat. No. 5,895,385 to Guglielmi, herein incorporated by reference, rely on high-density material such as gold, tantalum, tungsten, or platinum in the form of an annular band or coil. The radiopaque marker is then bonded to other, less dense materials, such as stainless steel, to differentiate the radiopaque section. Since the radiopaque marker is a separate element placed at a specified distance (often about 3 cm) from the tip of the delivery pusher, the placement must be exact or the distal tip of the delivery pusher **350** can result in damage to the aneurysm or other complications. For example, the delivery pusher **350** may be overextended from the microcatheter to puncture an aneurysm. Additionally, the manufacturing process to make a prior delivery pusher can be difficult and expensive, especially when bonding dissimilar materials.

The radiopaque system of the present invention overcomes these disadvantages by integrating a first radiopaque material into most of the delivery pusher **350** while varying the thickness of a second radiopaque material, thus eliminating the need to bond multiple sections together. As seen in FIG. 7, the delivery pusher **350** comprises a core mandrel **354** (i.e. the first radiopaque material), preferably made from radiopaque material such as tungsten, tantalum, platinum, or gold (as opposed to the mostly radiolucent materials of the prior art designs such as steel, Nitinol, and Elgiloy).

The delivery pusher **350** also includes a second, outer layer **352**, having a different radiopaque level. Preferably, outer layer **352** is composed of a material having a lower radiopaque value than the core mandrel **354**, such as Elgiloy, Nitinol, or stainless steel (commercially available from Fort Wayne Metals under the trade name DFT). In this respect, both the core mandrel **354** and the outer layer **352** are visible and distinguishable from each other under fluoroscopy. The outer layer **352** varies in thickness along the length of the delivery pusher **350** to provide increased flexibility and differentiation in radio-density. Thus the thicker regions of the outer layer **352** are more apparent to the user than the thinner regions under fluoroscopy.

The transitions in thickness of the outer layer **352** can be precisely created at desired locations with automated processes such as grinding, drawing, or forging. Such automated processes eliminate the need for hand measuring and placement of markers and further eliminates the need to bond a separate marker element to other radiolucent sections, thus reducing the manufacturing cost and complexity of the system.

In the present embodiment, the delivery pusher **350** includes three main indicator regions of the outer layer **352**. A proximal region **356** is the longest of the three at 137 cm, while a middle region **358** is 10 cm and a distal region **360** is 3 cm. The length of each region can be determined based on the use of the delivery pusher **350**. For example, the 3 cm distal region **360** may be used during a coil implant procedure, as known in the art, allowing the user to align the proximal edge of the distal region **360** with a radiopaque marker on the microcatheter within which the delivery pusher **350** is positioned. The diameter of each of the regions depends on the application and size of the implant. For a typical cerebral aneurysm application for example, the proximal region **356** may typically measure 0.005-0.015 inches, the middle region **358** may typically measure 0.001-0.008 inches, while the distal region **360** may typically measure 0.0005-0.010 inches. The core mandrel **354** will typically

comprise between about 10-80% of the total diameter of the delivery pusher **350** at any point.

Alternately, the delivery pusher **350** may include any number of different regions greater than or less than the three shown in FIG. 7. Additionally, the radiopaque material of the core mandrel **354** may only extend partially through the delivery pusher **350**. For example, the radiopaque material could extend from the proximal end of the core mandrel **354** to three centimeters from the distal end of the delivery pusher **350**, providing yet another predetermined position marker visible under fluoroscopy.

In this respect, the regions **356**, **358**, and **360** of delivery pusher **350** provide a more precise radiopaque marking system that is easily manufactured, yet is readily apparent under fluoroscopy. Further, the increased precision of the markers may decrease complications relating to improper positioning of the delivery pusher during a procedure.

In operation, the microcatheter is positioned within a patient so that a distal end of the microcatheter is near a target area or lumen. The delivery pusher **350** is inserted into the proximal end of the microcatheter and the core mandrel **354** and outer layer **352** are viewed under fluoroscopy. The user aligns a radiopaque marker on the microcatheter with the beginning of the distal region **360**, which communicates the location of the implant **112**, **302** relative to the tip of the microcatheter.

In some situations, for example, small aneurysms where there may be an elevated risk of vessel damage from the stiffness of the delivery pusher **350**, the user may position the proximal end of the implant slightly within the distal end of the microcatheter during detachment. The user then may push the proximal end of the implant **112**, **302** out of the microcatheter with the next coil, an adjunctive device such as guidewire, or the delivery pusher **102**, **202**, **301**, or **350**. In another embodiment, the user may use the radiopaque marking system to locate the distal end of the delivery pusher outside the distal end of the microcatheter.

Once the implant device **112**, **302** of the detachment system **100**, **200**, or **300** is placed in or around the target site, the operator may repeatedly reposition the implant device **112**, **302** as necessary or desired.

When detachment of the implant device **112**, **302** at the target site is desired, the operator applies energy to the heater **106**, **206**, or **306** by way of the electrical wires **108**, **110**, **208**, **210**, **308**, or **309**. The electrical power source for the energy may be any suitable source, such as, e.g., a wall outlet, a capacitor, a battery, and the like. For one aspect of this method, electricity with a potential of approximately 1 volt to 100 volts is used to generate a current of 1 milliamp to 5000 milliamps, depending on the resistance of the detachment system **100**, **200**, or **300**.

One embodiment of a connector system **400** that can be used to electrically couple the detachment system **100**, **200**, or **300** to the power source is shown in FIG. 6. The connector system **400** includes an electrically conductive core mandrel **412** having a proximal end surrounded by an insulating layer **404**. Preferably the insulating layer **404** is an insulating sleeve such as a plastic shrink tube of polyolefin, PET, Nylon, PEEK, Teflon, or polyimide. The insulating layer **404** may also be a coating such as polyurethane, silicone, Teflon, paralyene. An electrically conductive band **406** is disposed on top of the insulating layer **404** and secured in place by molding bands **414**, adhesive, or epoxy. Thus, the core mandrel **412** and the conductive band **406** are electrically insulated from each other. The conductive band **406** is preferably composed of any electrically conductive material, such as silver, gold, platinum, steel, copper, conductive polymer, conductive

adhesive, or similar materials, and can be a band, coil, or foil. Gold is especially preferred as the conductive material of the conductive band **406** because of the ability of gold to be drawn into a thin wall and its ready availability. The core mandrel **412** has been previously described and may be plated with, for example, gold, silver, copper, or aluminum to enhance its electrical conductivity.

The connector system **400** also includes two electrical wires **408** and **410** which connect to the conductive band **406** and core member **412**, respectively, and to a heating element at the distal end of a delivery system such as those described in FIGS. **1**, **2**, and **4** (not shown in FIG. **6**). These wires **408** and **410** are preferably connected by soldering, brazing, welding, laser bonding, or conductive adhesive, or similar techniques.

Once the user is ready to release the implant **112**, **302** within the patient, a first electrical clip or connector from a power source is connected to a non-insulated section **402** of the core mandrel **412** and a second electrical clip or connector from the power source is connected to the conductive band **406**. Electrical power is applied to the first and second electrical clips, forming an electrical circuit within the detachment system **100**, **200**, or **300**, causing the heater **106**, **206**, or **306** to increase in temperature and sever the tether **104**, **310**.

Once the detachment system **100**, **200**, or **300** is connected to the power source the user may apply a voltage or current as previously described. This causes the heater **106**, **206**, or **306** to increase in temperature. When heated, the pre-tensioned tether **104**, **310** will tend to recover to its unstressed (shorter) length due to heat-induced creep. In this respect, when the tether **104**, **310** is heated by the heater **106**, **206**, or **306**; its overall size shrinks. However, since each end of the tether **104**, **310** is fixed in place as previously described, the tether **104**, **310** is unable to shorten in length, ultimately breaking to release the implant device **112**, **302**.

Because there is tension already within the system in the form of a spring **116** or deformation of the tether material **104**, **310**; the amount of shrinkage required to break the tether **104**, **310** is less than that of a system without a pre-tensioned tether. Thus, the temperature and time required to free the implant device **112**, **302** is lower.

FIG. **5** is a graph showing the relationship between the temperature at the surface of PET cover **304** of the detachment system **300** and the time duration in which the heater coil **306** is activated. As can be seen, the surface temperature of the detachment system **300** during detachment does not vary linearly with time. Specifically, it takes just under 1 second for the heat generated by the heating coil **306** to penetrate the insulating cover **304**. After 1 second, the surface temperature of the insulating cover **304** dramatically increases. Although different outer insulating material may slightly increase or decrease this 1-second surface temperature window, the necessarily small diameter of the detachment system **100**, **200**, or **300** prevents providing a thick insulating layer that may more significantly delay a surface temperature increase.

It should be understood that the embodiments of the detachment system **100**, **200**, or **300** include a variety of possible constructions. For example, the insulating cover **304** may be composed of Teflon, PET, polyamide, polyimide, silicone, polyurethane, PEEK, or materials with similar characteristics. In the embodiments **100**, **200**, or **300** the typical thickness of the insulating cover is 0.0001-0.040 inches. This thickness will tend to increase when the device is adapted for use in, for example, proximal malformations, and decrease when the device is adapted for use in more distal, tortuous locations such as, for example, cerebral aneurysms.

In order to minimize the damage and possible complications caused by such a surface temperature increase, the present invention detaches the implant device **112**, **302** before the surface temperature begins to significantly increase. Preferably, the implant device **112**, **302** is detached in less than a second, and more preferably, in less than 0.75 seconds. This prevents the surface temperature from exceeding 50° C. (122° F.), and more preferably, from exceeding 42° C. (107° F.).

Once the user attempts to detach the implant device **112**, **302**, it is often necessary to confirm that the detachment has been successful. The circuitry integrated into the power source may be used to determine whether or not the detachment has been successful. In one embodiment of the present invention an initial signaling current is provided prior to applying a detachment current (i.e. current to activate the heater **106**, **206**, or **306** to detach an implant **112**, **302**). The signaling current is used to determine the inductance in the system before the user attempts to detach the implant and therefore has a lower value than the detachment current, so as not to cause premature detachment. After an attempted detachment, a similar signaling current is used to determine a second inductance value that is compared to the initial inductance value. A substantial difference between the initial inductance and the second inductance value indicates that the implant **112**, **302** has successfully been detached, while the absence of such a difference indicates unsuccessful detachment. In this respect, the user can easily determine if the implant **112**, **302** has been detached, even for delivery systems that utilize nonconductive temperature sensitive polymers to attach an implant, such as those seen in FIGS. **1**, **2**, and **4**.

In the following description and examples, the terms “current” and “electrical current” are used in the most general sense and are understood to encompass alternating current (AC), direct current (DC), and radiofrequency current (RF) unless otherwise noted. The term “changing” is defined as any change in current with a frequency above zero, including both high frequency and low frequency. When a value is measured, calculated and/or saved, it is understood that this may be done either manually or by any known electronic method including, but not limited to, an electronic circuit, semiconductor, EPROM, computer chip, computer memory such as RAM, ROM, or flash; and the like. Finally, wire windings and toroid shapes carry a broad meaning and include a variety of geometries such as circular, elliptical, spherical, quadrilateral, triangular, and trapezoidal shapes.

When a changing current passes through such objects as wire windings or a toroid, it sets up a magnetic field. As the current increases or decreases, the magnetic field strength increase or decreases in the same way. This fluctuation of the magnetic field causes an effect known as inductance, which tends to oppose any further change in current. Inductance ( $L$ ) in a coil wound around a core is dependant on the number of turns ( $N$ ), the cross-sectional area of the core ( $A$ ), the magnetic permeability of the core ( $\mu$ ), and length of the coil ( $l$ ) according to equation 1 below:

$$L = \frac{0.4\pi N^2 A \mu}{l} \quad \text{Equation 1}$$

The heater **106** or **306** is formed from a wound coil with proximal and distal electrically conductive wires **108**, **110**, **308**, or **309** attached to a power source. The tether **104**, **310** has a magnetic permeability  $\mu_1$  and is positioned through the center of the resistive heater, having a length  $l$ , cross sectional

area A, and N winds, forming a core as described in the previous equation. Prior to detachment, a changing signaling current  $i_1$ , such as the waveforms shown in FIGS. 3A and 3B, with frequency  $f_1$ , is sent through the coil windings. This signaling current is generally insufficient to detach the implant. Based on the signaling current, the inductive resistance  $X_L$  (i.e. the electrical resistance due to the inductance within the system) is measured by an electronic circuit such as an ohmmeter. The initial inductance of the system  $L_1$  is then calculated according to the formula:

$$L_1 = \frac{X_L}{2\pi f_1}. \quad \text{Equation 2}$$

This initial value of the inductance  $L_1$  depends on the magnetic permeability  $\mu_1$  of the core of the tether **104, 310** according to Equation 1, and is saved for reference. When detachment is desired, a higher current and/or a current with a different frequency than the signaling current is applied through the resistive heater coil, causing the tether **104, 310** to release the implant **112, 302** as previously described. If detachment is successful, the tether **104, 310** will no longer be present within the heater **106, 306** and the inside of the heater **106, 306** will fill with another material such as the patient's blood, contrast media, saline solution, or air. This material now within the heater core will have a magnetic permeability  $\mu_2$  that is different than the tether core magnetic permeability  $\mu_1$ .

A second signaling current and frequency  $f_2$  is sent through the heater **106, 306** and is preferably the same as the first signaling current and frequency, although one or both may be different without affecting the operation of the system. Based on the second signaling current, a second inductance  $L_2$  is calculated. If the detachment was successful, the second inductance  $L_2$  will be different (higher or lower) than the first inductance  $L_1$  due to the difference in the core magnetic permeabilities  $\mu_1$  and  $\mu_2$ . If the detachment was unsuccessful, the inductance values should remain relatively similar (with some tolerance for measurement error). Once detachment has been confirmed by comparing the difference between the two inductances, an alarm or signal can be activated to communicate successful detachment to the user. For example, the alarm might include a beep or an indicator light.

Preferably, the delivery system **100, 300** used according to this invention connects to a device that automatically measures inductance at desired times, performs required calculations, and signals to the user when the implant device has detached from the delivery catheter. However, it should be understood that part or all of these steps can be manually performed to achieve the same result.

The inductance between the attached and detached states can also preferably be determined without directly calculating the inductance. For example, the inductive resistance  $X_L$  can be measured and compared before and after detachment. In another example, the detachment can be determined by measuring and comparing the time constant of the system, which is the time required for the current to reach a predetermined percentage of its nominal value. Since the time constant depends on the inductance, a change in the time constant would similarly indicate a change in inductance.

The present invention may also include a feedback algorithm that is used in conjunction with the detachment detection described above. For example, the algorithm automatically increases the detachment voltage or current automatically after the prior attempt fails to detach the

implant device. This cycle of measurement, attempted detachment, measurement, and increased detachment voltage/current continues until detachment is detected or a predetermined current or voltage limit is attained. In this respect, a low power detachment could be first attempted, followed automatically by increased power or time until detachment has occurred. Thus, battery life for a mechanism providing the detachment power is increased while the average coil detachment time is greatly reduced.

Referring now to FIGS. 9 and 10, there is shown an embodiment of an implant delivery system **500** of the present invention. The implant delivery system **500** and connector system **501** are generally similar to the delivery pusher **301** and connector system **400**, respectively, previously described in this application and shown in FIGS. 4 and 6. However, the implant delivery system **500** preferably includes a sensor **502** for detecting when the implant device **302** has been advanced out of a microcatheter **506** to a desired detachment location.

Generally, detachment of the implant device **302** is preferred once the implant device **302** has fully exited the microcatheter **506**. In this respect, the sensor **502** is positioned proximal to the implant device **302** on the pusher **301**. The sensor **502** detects a change in its environment (i.e., from a location within the microcatheter **506** to a location outside the microcatheter **506**, within vasculature of a patient) which is conveyed along wires **504** to the connector system **501** and ultimately to a human interface or display device (not shown) near the user. Preferably, the human interface may include a meter, electronic display, audible tone, or the like.

In yet another preferred embodiment not shown in the figures, the implant device **302** is utilized as a detection mechanism instead of or in addition to the sensor **502**. During navigation of the pusher **500** to the target deployment site within the vasculature, the pusher **500** remains within the microcatheter **506** and the coil of the implant device **302** remains relatively straight, as it is confined by the walls defining the internal lumen of the microcatheter **506**. When the implant assembly is deployed, the coil of the implant device **302** returns to a curved configuration. The relative resistance of the coil of the implant device **302** from its distal end to its proximal end changes as the coil changes from a straight to a coiled configuration. Thus, the change in resistance can be used as a location detection mechanism.

In one preferred embodiment, the sensor **502** may be a temperature sensor, detecting the temperature differential (e.g., a change from a normal or unbiased state) between the inside and outside of the microcatheter **506**. Due to the relatively short period of time during which the microcatheter **506** is disposed within the vasculature, the internal temperature of the microcatheter **506** is typically cooler than the temperature of the vasculature. Hence, the temperature increases markedly as the sensor **502** reaches the detachment zone (i.e., a position of preferred detachment) just outside the microcatheter **506**. This jump in temperature is thus used as an indication that the detachment zone has been reached during the advancement of the implant device **302**.

In another preferred embodiment, the sensor **502** is a pressure sensor for detecting a pressure differential (e.g., a change from a normal or unbiased state) inside and outside of the microcatheter **506**. The pressure inside the microcatheter **506** is relatively constant, whereas the pressure outside the microcatheter **506** varies with systole and diastole of the blood stream. Hence, the sudden change of pressure from a relatively static reading to a dynamic reading can be used as an indication that the implant device **302** has been advanced to the detachment zone.

In another preferred embodiment, the sensor 502 includes both an ultrasound transceiver and sensor for detecting an ultrasound differential (e.g., a change from a normal or unbiased state) between an inside and outside of the microcatheter 506. The ultrasonic transceiver sends ultrasonic waves and receives echoes of the waves in order to determine distances to objects surrounding the transceiver. The walls of the microcatheter are much closer to the transceiver than the walls of the vasculature. Hence, the sudden increase in distance measured by the transceiver can be used as an indication that the implant device 302 has been advanced to the desired detachment zone.

Other sensors capable of detecting differential characteristics between an inside and outside of a microcatheter 506 may also be used.

In another preferred embodiment, the heater coil 306 may serve as a sensor instead of or in addition to sensor 502. A resistance differential (e.g., a change from a normal or unbiased state) of the heater coil 306 may be measured as it is advanced through the microcatheter 506. As the heater coil 502 exits the microcatheter 506, the environment surrounding the heater coil changes from dry and relatively cool, to the warm blood filled environment of the vasculature. This change in environment affects the resistance of the heater coil 306 to a measurable degree. The following example is provided to show data obtained using the heater coil 306 as a sensor:

Examples

A series of experiments were conducted to determine the resistance change of heater coils as they are advanced through a microcatheter. The procedure used in order to obtain the data was as follows:

1. Obtain coil pusher
2. Prepare flow model.
3. Measure and record coil resistance on gold connector.
4. Advance coil pusher into microcatheter slightly beyond hub at proximal end.
5. Measure and record coil resistance. Mark data as 0% pusher length.
6. Advance coil pusher roughly 50% of entire length. Measure and record coil resistance. Mark data as 50% pusher length.

7. Repeat step 6 for 75% and 100% of pusher length, 100% being defined as the detachment zone exiting the distal end of the microcatheter.

8. Retract pusher and stop at above steps (75%, 50%, and 0%) and measure and record data.

9. Repeat cycle 3 times.

10. Measure and record coil pusher resistance one last time in air, outside of the microcatheter.

11. Detach implant and record results.

The following data were collected using various catheter types and heater coil materials. All resistance values shown in Tables 1-3 are in Ohms. Blank values indicate no data was obtained. Percent pusher length is defined as percentage of the pusher inserted into microcatheter, e.g. 100 percent equals detachment coil exited from distal end of microcatheter. Resistance was measured from gold connectors at proximal end of pusher.

As a result of this data, a conclusion was drawn that of the two heater coil materials tested, namely Stablohm and platinum, Stablohm had a coefficient of thermal resistivity that is much higher than that of the platinum. Other materials with a higher coefficient of thermal resistivity may be used to provide a higher sensitivity of the reading instrument. Moreover, the data show that there is a difference in the advancing coil resistance of approximately 0.5 ohm for the platinum coil and 0.4 ohm for the stablohm (from 75%-100% mark).

Example 1

The microcatheter used for Example 1 was a Rapid Transit microcatheter. The heater coil material used was Stablohm 710. The flow temperature was 99 degrees F. The heater coil resistance before testing was 42.1 Ohm. The heater coil resistance after the test was not recorded. Table 1 shows the results of Example 1.

TABLE 1

Percent Pusher Length	Advance Resistance 1	Advance Resistance 2	Retract Resistance 1
0	42.1	42.1	42.1
50	42.2	—	42.2
75	42.5	42.5	—
100	42.6	42.6	42.6

Example 2

The microcatheter used for Example 2 was an Excelsior 1018 microcatheter. The heater coil material used was Platinum. The flow temperature was 98.7 degrees F. The heater coil resistance before testing was 40.9 Ohm, and the heater coil resistance after the test was 40.9 Ohm. Table 2 shows the results of Example 2.

TABLE 2

Percent Pusher Length	Advance Resistance 1	Advance Resistance 2	Advance Resistance 3	Retract Resistance 1	Retract Resistance 2	Retract Resistance 3
0	40.8	41.0	41.0	41.0	41.0	41.0
50	40.9	41.2	41.1	41.1	41.1	41.1
75	41.2	—	41.3	—	—	41.2
100	41.7	41.6	41.6	41.7	41.6	41.6

Example 3

The microcatheter used for Example 3 was an Excelsior SL10 microcatheter. The heater coil material used was Platinum. The flow temperature was 98.6 degrees F. The heater coil resistance before testing was 40.8 Ohm, and the heater coil resistance after the test was 40.7 Ohm. Table 3 shows the results of Example 3.

TABLE 3

Percent Pusher Length	Advance Resistance 1	Advance Resistance 2	Advance Resistance 3	Retract Resistance 1	Retract Resistance 2	Retract Resistance 3
0	40.8	40.9	40.8	40.9	40.8	40.7
50	41.0	41.0	41.0	41.0	40.9	41.0
75	41.1	41.2	41.2	41.2	41.1	41.2
100	41.6	41.6	41.7	41.6	41.6	41.7

Although the invention has been described in terms of particular embodiments and applications, one of ordinary skill in the art, in light of this teaching, can generate additional embodiments and modifications without departing from the spirit of or exceeding the scope of the claimed invention. Accordingly, it is to be understood that the drawings and descriptions herein are proffered by way of example to facilitate comprehension of the invention and should not be construed to limit the scope thereof.

What is claimed is:

1. A system for determining when an implant has advanced out of a microcatheter comprising:
  - a microcatheter having a lumen and a distal end;
  - a pusher disposed within the lumen of the microcatheter; an implant device advanceable through the lumen by the pusher; and
  - a sensor system comprising a resistance-type heater coil located within the microcatheter and disposed proximate the implant; the sensor system calibrated to monitor a resistance of the heater coil, determine a resistance change due to blood entering the microcatheter, and signal when the implant has advanced completely out of the distal end of the microcatheter.
2. The system of claim 1, further comprising a human interface device in data-flow communication with the sensor.
3. A system for determining when an implant has advanced out of a microcatheter comprising:

10

a microcatheter having a lumen and a distal end; a pusher movable through the lumen of the microcatheter; an implant device advanceable through said lumen by the pusher; and

15

a sensor assembly comprising a resistance-type heater coil disposed near the distal end of the microcatheter; the sensor system configured to measure and monitor for a resistance change due to blood entering the microcatheter, and signal when the implant has advanced entirely out of said distal end of the microcatheter.

20

4. The system of claim 3, wherein the sensor assembly has been calibrated for use with the pusher.

5. A system for determining when an implant has advanced out of a catheter comprising:

25

a catheter having a lumen and a distal end; a pusher disposed within the lumen of the catheter; said implant advanceable through the lumen by the pusher; and

30

a sensor system comprising a resistance-type heater coil disposed proximate the implant and within the catheter; the sensor system calibrated to monitor resistance of the heater coil, determine a resistance change due to blood entering the catheter, and signal when the implant has advanced fully out of the distal end of the catheter.

35

6. The system of claim 5, wherein the sensor system has been calibrated for use with the pusher.

\* \* \* \* \*

专利名称(译)	用于定位可拆卸植入物的分离区的系统和方法		
公开(公告)号	<a href="#">US9242070</a>	公开(公告)日	2016-01-26
申请号	US12/340546	申请日	2008-12-19
[标]申请(专利权)人(译)	微温森公司		
申请(专利权)人(译)	MicroVention公司, INC.		
当前申请(专利权)人(译)	MICRONVENTION INC.		
[标]发明人	TIEU TAI D		
发明人	TIEU, TAI, D.		
IPC分类号	A61M29/00 A61B5/00 A61M25/00 A61B17/12 A61F2/95 A61M25/01 A61F2/966 A61M25/06 A61F2/30		
CPC分类号	A61M25/0082 A61B17/1214 A61B17/12022 A61B17/12109 A61B17/12113 A61B17/12122 A61B17/12154 A61F2/95 A61M25/0108 A61B2017/12068 A61F2/966 A61F2002/30668 A61F2002/9505 A61F2250/0001 A61M25/0068 A61M2025/0042 A61M2025/0681 A61M2205/3331 A61M2205/3368 A61M2205/3375 A61M2205/3653 A61B8/0841 A61B2017/00292 A61B2034/2053 A61B2562/0247 A61B2562/0257 A61B2562/0271		
优先权	61/016154 2007-12-21 US		
其他公开文献	US20090163780A1		
外部链接	<a href="#">Espacenet</a> <a href="#">USPTO</a>		

摘要(译)

一种用于快速分离植入物并用于定位可分离植入物的分离区的系统和方法。当传感器从微导管内通过到暴露于脉管系统时，传感器确定局部环境的突然变化。传感器可以是温度传感器，超声波传感器，压力传感器等。如果可分离植入物组件使用加热器线圈来分离植入物，则加热器线圈可以用作传感器。另外，如果当植入物离开微导管并改变形状时可以检测到电阻的变化，则植入物本身可以用作传感器。

