

US008758372B2

(12) **United States Patent**
Cartledge et al.

(10) **Patent No.:** **US 8,758,372 B2**
(45) **Date of Patent:** **Jun. 24, 2014**

(54) **IMPLANTABLE DEVICES FOR CONTROLLING THE SIZE AND SHAPE OF AN ANATOMICAL STRUCTURE OR LUMEN**

A61B 17/068 (2006.01)
A61B 19/00 (2006.01)
A61B 6/12 (2006.01)
A61F 2/30 (2006.01)
A61F 2/00 (2006.01)
A61B 17/04 (2006.01)

(75) Inventors: **Richard G. Cartledge**, Fort Lauderdale, FL (US); **Leonard Y. Lee**, New York, NY (US); **James I. Fann**, Portola Valley, CA (US); **Josef L. Friedmann**, Scotts Valley, CA (US); **James L. Greene**, Fort Lauderdale, FL (US)

(52) **U.S. CL.**
CPC *A61F 2/2442* (2013.01); *A61B 17/00234* (2013.01); *A61F 2250/0029* (2013.01); *A61B 2017/00243* (2013.01); *A61B 2017/00783* (2013.01); *A61B 2019/462* (2013.01); *A61F 2/2466* (2013.01); *A61B 6/12* (2013.01); *A61F 2/2445* (2013.01); *A61B 17/0644* (2013.01); *A61B 2017/00455* (2013.01); *A61F 2002/30537* (2013.01); *A61F 2250/0004* (2013.01); *A61F 2/0031* (2013.01); *A61B 5/6885* (2013.01); *A61B 2017/0496* (2013.01); *A61F 2/2448* (2013.01); *A61B 5/061* (2013.01); *A61B 2017/0641* (2013.01); *A61B 17/068* (2013.01)
USPC **606/151**; 623/2.37

(73) Assignee: **St. Jude Medical, Cardiology Division, Inc.**, St. Paul, MN (US)

(*) Notice: Subject to any disclaimer, the term of this patent is extended or adjusted under 35 U.S.C. 154(b) by 1060 days.

(21) Appl. No.: **11/802,264**

(22) Filed: **May 21, 2007**

(65) **Prior Publication Data**
US 2008/0027483 A1 Jan. 31, 2008

(58) **Field of Classification Search**
USPC 606/151, 153, 158, 218, 201, 203; 33/512; 623/2.36, 2.37; 600/37
See application file for complete search history.

Related U.S. Application Data

(63) Continuation-in-part of application No. 10/651,840, filed on Aug. 29, 2003, now Pat. No. 7,297,150.

(60) Provisional application No. 60/406,841, filed on Aug. 29, 2002, provisional application No. 60/444,005, filed on Jan. 31, 2003, provisional application No. 60/447,383, filed on Feb. 14, 2003, provisional application No. 60/462,435, filed on Apr. 12, 2003, provisional application No. 60/801,861, filed on May 19, 2006.

(51) **Int. Cl.**
A61B 17/08 (2006.01)
A61F 2/24 (2006.01)
A61B 17/00 (2006.01)
A61B 17/064 (2006.01)
A61B 5/00 (2006.01)
A61B 5/06 (2006.01)

(56) **References Cited**

U.S. PATENT DOCUMENTS

3,875,928 A	4/1975	Angelchik
4,042,979 A	8/1977	Angell
4,489,446 A	12/1984	Reed
4,602,911 A	7/1986	Ahmadi et al.
4,676,253 A	6/1987	Newman et al.
5,064,431 A	11/1991	Gilbertson et al.
5,102,417 A	4/1992	Palmaz
5,119,674 A	6/1992	Nielsen
5,201,880 A	4/1993	Wright et al.
5,243,976 A	9/1993	Ferek-Petric et al.
5,306,296 A	4/1994	Wright et al.
5,405,378 A	4/1995	Strecker
5,411,552 A	5/1995	Andersen et al.
5,423,851 A	6/1995	Samuels
5,443,477 A	8/1995	Marin et al.
5,522,884 A	6/1996	Wright
5,593,424 A	1/1997	Northrup III
5,601,604 A	2/1997	Vincent

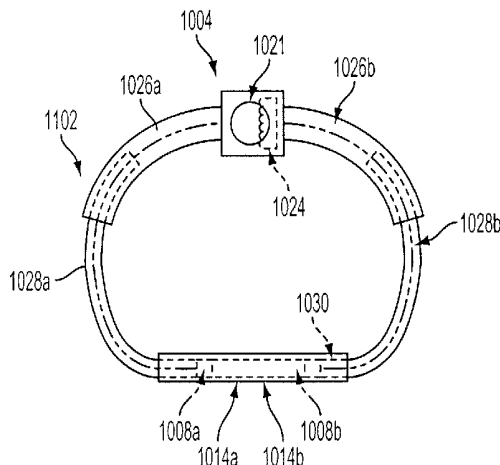

5,674,279	A	10/1997	Wright et al.	7,361,190	B2	4/2008	Shaoulian et al.
5,709,695	A	1/1998	Northrup, III	7,377,916	B2	5/2008	Rudko et al.
5,709,701	A	1/1998	Parodi	7,381,219	B2	6/2008	Salahieh et al.
5,713,951	A	2/1998	Garrison et al.	7,416,557	B2	8/2008	Drasler et al.
5,769,812	A	6/1998	Stevens	7,442,207	B2	10/2008	Rafiee
5,814,097	A	9/1998	Sterman et al.	7,455,690	B2	11/2008	Cartledge et al.
5,824,055	A	10/1998	Spiridigliozzi et al.	7,527,647	B2	5/2009	Spence
5,908,435	A	6/1999	Samuels	7,655,040	B2	2/2010	Douk et al.
5,961,539	A	10/1999	Northrup, III	7,666,204	B2	2/2010	Thornton et al.
5,972,030	A	10/1999	Garrison et al.	7,780,683	B2	8/2010	Roue et al.
5,984,959	A	11/1999	Robertson et al.	7,815,676	B2	10/2010	Greenberg
5,989,284	A	11/1999	Laufer	7,842,098	B2	11/2010	Rioux et al.
6,067,991	A	5/2000	Forsell	8,226,707	B2	7/2012	White
6,110,200	A *	8/2000	Hinnenkamp 623/2.11	8,236,049	B2	8/2012	Rowe et al.
6,152,144	A	11/2000	Lesh et al.	8,241,351	B2	8/2012	Cabiri
6,152,936	A	11/2000	Christy et al.	8,470,023	B2	6/2013	Eidenschink et al.
6,168,616	B1	1/2001	Brown, III	2001/0021874	A1	9/2001	Carpentier et al.
6,187,040	B1	2/2001	Wright	2002/0095175	A1	7/2002	Brock et al.
6,217,610	B1 *	4/2001	Carpentier et al. 623/2.37	2002/0107540	A1	8/2002	Whalen et al.
6,231,561	B1	5/2001	Frazier et al.	2002/0128708	A1	9/2002	Northrup et al.
6,245,012	B1	6/2001	Kleshinski	2002/0151961	A1	10/2002	Lashinski et al.
6,269,819	B1	8/2001	Oz et al.	2002/0151967	A1	10/2002	Mikus et al.
6,355,030	B1	3/2002	Aldrich et al.	2002/0173841	A1	11/2002	Ortiz et al.
6,368,348	B1	4/2002	Gabbay	2003/0018358	A1	1/2003	Saadat
6,402,781	B1	6/2002	Langberg et al.	2003/0040791	A1	2/2003	Oktay
6,406,493	B1	6/2002	Tu et al.	2003/0050649	A1	3/2003	Brock et al.
6,419,696	B1	7/2002	Ortiz et al.	2003/0050693	A1	3/2003	Quijano et al.
6,451,054	B1	9/2002	Stevens	2003/0074012	A1	4/2003	Nguyen et al.
6,464,707	B1	10/2002	Bjerken	2003/0083742	A1 *	5/2003	Spence et al. 623/2.16
6,470,892	B1 *	10/2002	Forsell 128/899	2003/0093148	A1	5/2003	Bolling et al.
6,514,265	B2	2/2003	Ho et al.	2003/0130730	A1	7/2003	Cohn et al.
6,524,338	B1	2/2003	Gundry	2003/0199974	A1	10/2003	Lee et al.
6,537,314	B2	3/2003	Langberg et al.	2003/0233142	A1	12/2003	Morales et al.
6,547,801	B1	4/2003	Dargent et al.	2004/0011365	A1	1/2004	Govari et al.
6,551,332	B1	4/2003	Nguyen et al.	2004/0019378	A1	1/2004	Hlavka et al.
6,564,805	B2	5/2003	Garrison et al.	2004/0030382	A1	2/2004	St. Goar et al.
6,607,541	B1	8/2003	Gardiner et al.	2004/0068276	A1	4/2004	Golden et al.
6,613,059	B2	9/2003	Schaller et al.	2004/0088047	A1	5/2004	Spence et al.
6,619,291	B2	9/2003	Hlavka et al.	2004/0111099	A1	6/2004	Nguyen et al.
6,629,534	B1	10/2003	Goar et al.	2004/0127980	A1	7/2004	Kowalsky et al.
6,641,593	B1	11/2003	Schaller et al.	2004/0133147	A1	7/2004	Woo
6,651,671	B1	11/2003	Donlon et al.	2004/0138744	A1	7/2004	Lashinski et al.
6,689,164	B1	2/2004	Seguin	2004/0148019	A1	7/2004	Vidlund et al.
6,706,065	B2	3/2004	Langberg et al.	2004/0148021	A1	7/2004	Cartledge et al.
6,709,456	B2	3/2004	Lanberg et al.	2004/0153144	A1	8/2004	Seguin
6,716,243	B1	4/2004	Colvin et al.	2004/0153147	A1	8/2004	Mathis
6,723,038	B1	4/2004	Schroeder et al.	2004/0162611	A1	8/2004	Marquez
6,749,630	B2	6/2004	McCarthy et al.	2004/0172046	A1	9/2004	Hlavka et al.
6,767,362	B2	7/2004	Schreck	2004/0176840	A1	9/2004	Lanberg et al.
6,776,789	B2	8/2004	Bryant et al.	2004/0181238	A1	9/2004	Zarbatany et al.
6,790,229	B1	9/2004	Berklouw	2004/0186566	A1	9/2004	Hindrichs et al.
6,793,673	B2	9/2004	Kowalsky et al.	2004/0193191	A1	9/2004	Starksen et al.
6,797,002	B2	9/2004	Spence et al.	2004/0204760	A1	10/2004	Fitz et al.
6,800,090	B2	10/2004	Alferness et al.	2004/0225353	A1	11/2004	McGuckin et al.
6,810,882	B2	11/2004	Langberg et al.	2004/0243153	A1	12/2004	Liddicoat et al.
6,824,562	B2	11/2004	Mathis et al.	2004/0249453	A1	12/2004	Cartledge et al.
6,840,246	B2	1/2005	Downing	2005/0060030	A1	3/2005	Lashinski et al.
6,872,223	B2	3/2005	Roberts et al.	2005/0065550	A1	3/2005	Starksen et al.
6,893,459	B1	5/2005	Macoviak	2005/0070999	A1	3/2005	Spence et al.
6,908,478	B2	6/2005	Alferness et al.	2005/0075736	A1	4/2005	Collazo
6,908,482	B2	6/2005	McCarthy et al.	2005/0107886	A1	5/2005	Crabtree et al.
6,911,035	B1	6/2005	Blomme	2005/0119734	A1	6/2005	Spence et al.
6,921,407	B2	7/2005	Nguyen et al.	2005/0119735	A1	6/2005	Spence et al.
6,926,715	B1	8/2005	Hauck et al.	2005/0131533	A1	6/2005	Alfieri et al.
6,932,838	B2	8/2005	Schwartz et al.	2005/0143766	A1	6/2005	Bachmann et al.
6,942,694	B2	9/2005	Liddicoat et al.	2005/0149114	A1	7/2005	Cartledge et al.
6,974,476	B2	12/2005	McGuckin, Jr. et al.	2005/0192601	A1	9/2005	Demarais
6,986,738	B2	1/2006	Glukhovskiy et al.	2005/0216079	A1	9/2005	MaCoviak
6,989,028	B2	1/2006	Lashinski et al.	2005/0222678	A1	10/2005	Lashinski et al.
7,011,082	B2	3/2006	Husges	2006/0074485	A1	4/2006	Realyvasquez
7,011,682	B2	3/2006	Lashinski et al.	2006/0100697	A1	5/2006	Casanova
7,097,658	B2	8/2006	Oktay	2006/0106405	A1	5/2006	Fann et al.
7,169,141	B2	1/2007	Brock et al.	2006/0135964	A1	6/2006	Vesely
7,175,660	B2	2/2007	Cartledge et al.	2006/0241748	A1	10/2006	Lee et al.
7,179,225	B2	2/2007	Shluzas et al.	2007/0016287	A1	1/2007	Cartledge et al.
7,220,237	B2	5/2007	Gannoe et al.	2007/0051377	A1	3/2007	Douk et al.
7,258,701	B2	8/2007	Aram et al.	2007/0233239	A1	10/2007	Navia et al.
7,297,150	B2	11/2007	Cartledge et al.	2007/0244556	A1	10/2007	Rafiee et al.
7,329,280	B2	2/2008	Bolling et al.	2007/0250160	A1	10/2007	Rafiee

2007/0299543	A1	12/2007	Cartledge et al.
2008/0027483	A1	1/2008	Cartledge et al.
2008/0109076	A1	5/2008	Cartledge et al.
2008/0306586	A1	12/2008	Cartledge et al.
2009/0005760	A1	1/2009	Cartledge et al.
2009/0054974	A1	2/2009	McGuckin, Jr. et al.
2009/0062825	A1	3/2009	Pool et al.
2009/0125102	A1	5/2009	Cartledge et al.
2009/0210052	A1	8/2009	Forster et al.
2009/0234404	A1	9/2009	Fitzgerald et al.
2009/0248148	A1	10/2009	Shaolian et al.
2010/0161047	A1	6/2010	Cabiri
2010/0168835	A1	7/2010	Dorn
2010/0211166	A1	8/2010	Miller et al.
2010/0217385	A1	8/2010	Thompson et al.
2010/0305609	A1	12/2010	Cartledge et al.
2010/0331949	A1	12/2010	Habib
2011/0009956	A1	1/2011	Cartledge et al.
2011/0022168	A1	1/2011	Cartledge
2011/0066231	A1	3/2011	Cartledge et al.
2011/0093060	A1	4/2011	Cartledge et al.
2011/0093062	A1	4/2011	Cartledge et al.
2011/0118828	A1	5/2011	Thompson
2011/0196480	A1	8/2011	Cartledge
2011/0202130	A1	8/2011	Cartledge et al.
2011/0208283	A1	8/2011	Rust
2011/0208295	A1	8/2011	Cartledge et al.
2011/0257633	A1	10/2011	Cartledge et al.
2011/0257737	A1	10/2011	Fogarty et al.
2011/0264191	A1	10/2011	Rothstein
2012/0022633	A1	1/2012	Olson et al.
2012/0022640	A1	1/2012	Gross et al.
2012/0059458	A1	3/2012	Buchbinder et al.
2012/0123531	A1	5/2012	Tsukashima et al.
2012/0136436	A1	5/2012	Cabiri et al.
2012/0158115	A9	6/2012	Arnault De La Menardiere et al.
2012/0197379	A1	8/2012	Laske et al.
2012/0277842	A1	11/2012	Kunis
2013/0006352	A1	1/2013	Yaron
2013/0144371	A1	6/2013	Kavteladze
2013/0172977	A1	7/2013	Forde et al.

FOREIGN PATENT DOCUMENTS

EP	0495417	A1	7/1992
EP	1554990	A2	7/2005
EP	1611868	A2	1/2006
FR	01/26586	A1	4/2001
JP	61013818		1/1986
JP	05-049655		3/1993
JP	10-503399	A	3/1998
JP	3049359	B2	6/2000
JP	3180136	B2	4/2001
JP	3180136	B2	6/2001
JP	2002509448	A	3/2002
JP	2002523172	A	7/2002
JP	2002526194	A	8/2002
JP	2003533275	A	11/2003
JP	2004535851	A	12/2004
JP	2005537067	A	12/2005
JP	2006507104	A	3/2006
JP	2006520651	A	9/2006
JP	2006520670	A	9/2006
WO	9101697	A1	2/1991
WO	9315690	A2	8/1993
WO	9603938	A1	2/1996
WO	97/16135		5/1997
WO	97/16135	A1	5/1997
WO	9719655	A1	6/1997
WO	99/04730		2/1999
WO	99/04730	A1	2/1999
WO	99/30647		6/1999

WO	9960952	A1	12/1999
WO	00/03759		1/2000
WO	0015158	A1	3/2000
WO	0016700	A1	3/2000
WO	0150985	A1	7/2001
WO	2004/012583	A2	2/2004
WO	2004/019816	A2	3/2004
WO	2004019826	A1	3/2004
WO	2004047677	A2	6/2004
WO	2004/060217	A1	7/2004
WO	2004080336	A2	9/2004
WO	2004/112585	A2	12/2004
WO	2004/112651	A2	12/2004
WO	2004/112658	A1	12/2004
WO	2005/007036	A1	1/2005
WO	2005/007037	A1	1/2005
WO	2005/007219	A2	1/2005
WO	2005/009285	A2	2/2005
WO	2005/025644	A2	3/2005
WO	2005/046488	A2	5/2005
WO	2005/055883	A1	6/2005
WO	2005/062931	A2	7/2005
WO	2005084592	A2	9/2005
WO	2006/105084	A2	10/2006
WO	2007/136783	A2	11/2007
WO	2008/085814	A2	7/2008
WO	2009/052509	A1	4/2009
WO	2010/085649	A1	7/2010
WO	2010/085659	A1	7/2010

OTHER PUBLICATIONS

Int'l Search Report received in corresponding Int'l Application PCT/US06/11275.

U.S. Appl. No. 13/123,768.

Extended European Search Report for Application No. 10733913 dated Dec. 11, 2012.

Letter dated Jan. 27, 2011 from Richard H. Levinstein, Esq.

Int'l Search Report received in corresponding Int'l Application PCT/US06/11275, Sep. 24, 2007.

International Search Report, PCT/US2010/021822, dated Mar. 17, 2010.

U.S. Appl. No. 13/123,768, filed Apr. 12, 2011.

International Search Report, PCT/US2010/021810, dated Mar. 24, 2010.

Extended European Search Report for Application No. EP13166640 dated Jul. 1, 2013.

* cited by examiner

Primary Examiner — Julian W Woo

(74) *Attorney, Agent, or Firm* — Lerner, David, Littenberg, Krumholz & Mentlik, LLP

(57) ABSTRACT

An implantable device system for controlling the dimensions of internal anatomic passages corrects physiologic dysfunctions resulting from a structural lumen which is either too large or too small. Implantable devices are disclosed which employ various mechanisms for adjusting and maintaining the size of an orifice to which they are attached. Systems permit the implants to be implanted using minimally invasive procedures and permit final adjustments to the dimensions of the implants after the resumption of normal flow of anatomic fluids in situ.

29 Claims, 23 Drawing Sheets

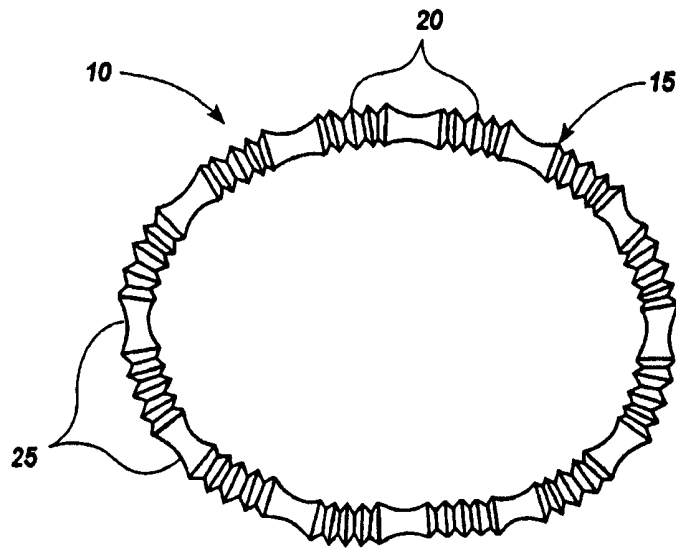

Fig. 1

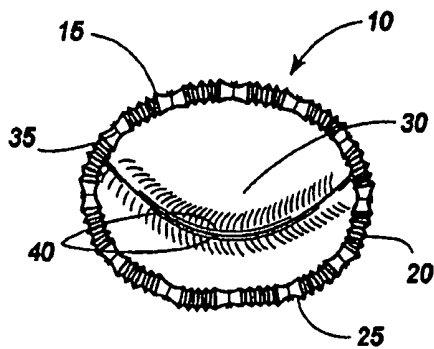

Fig. 2

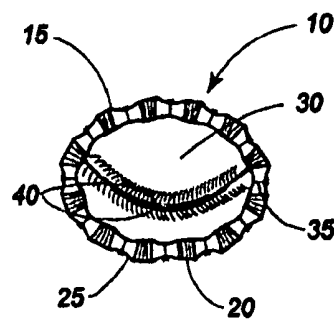
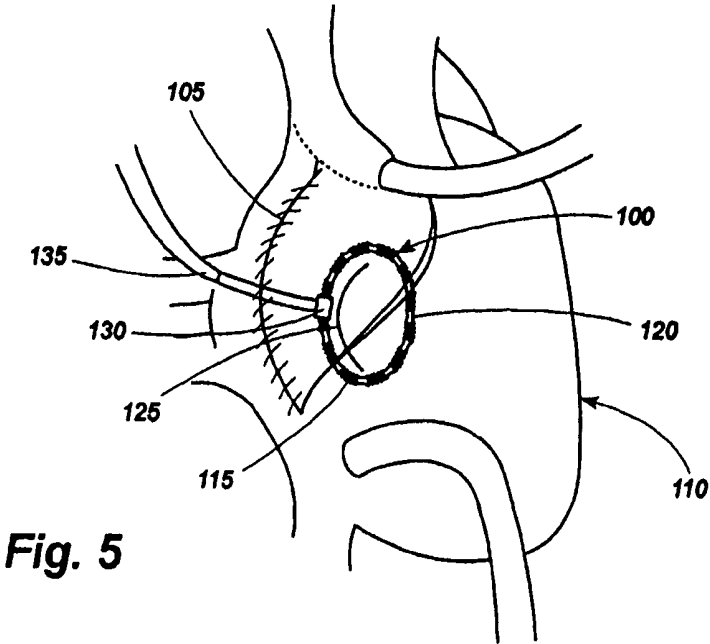
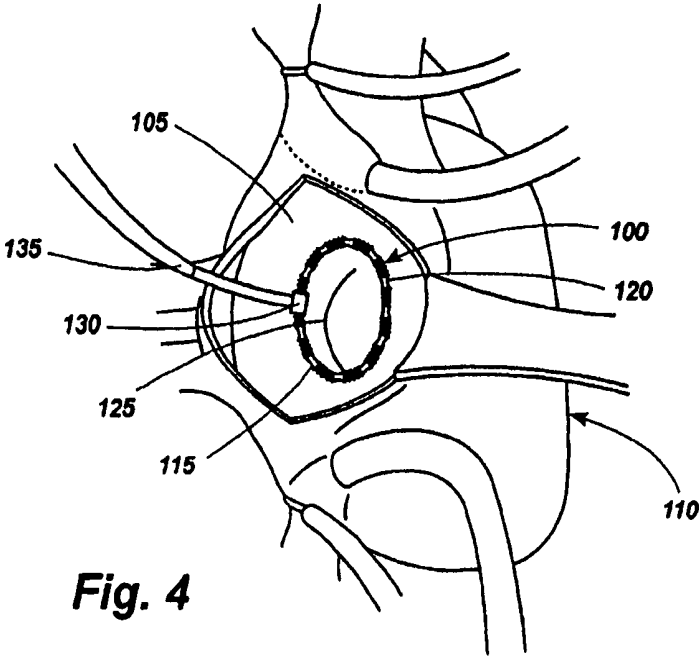
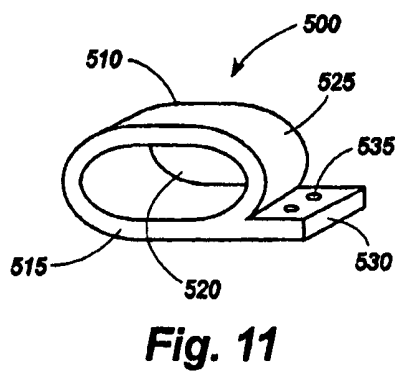
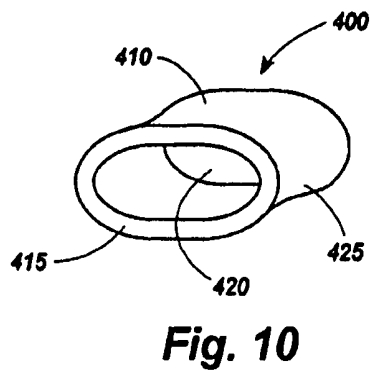
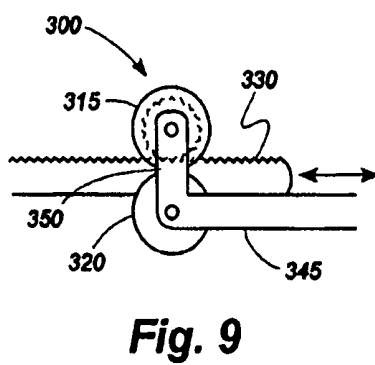
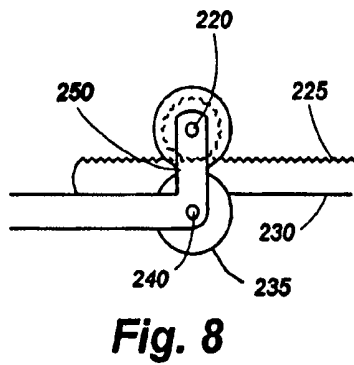
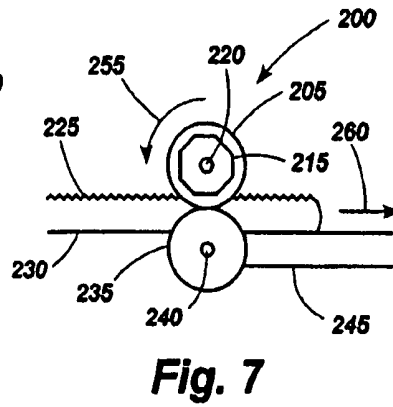
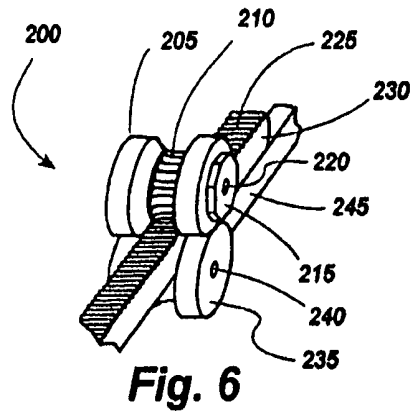

Fig. 3





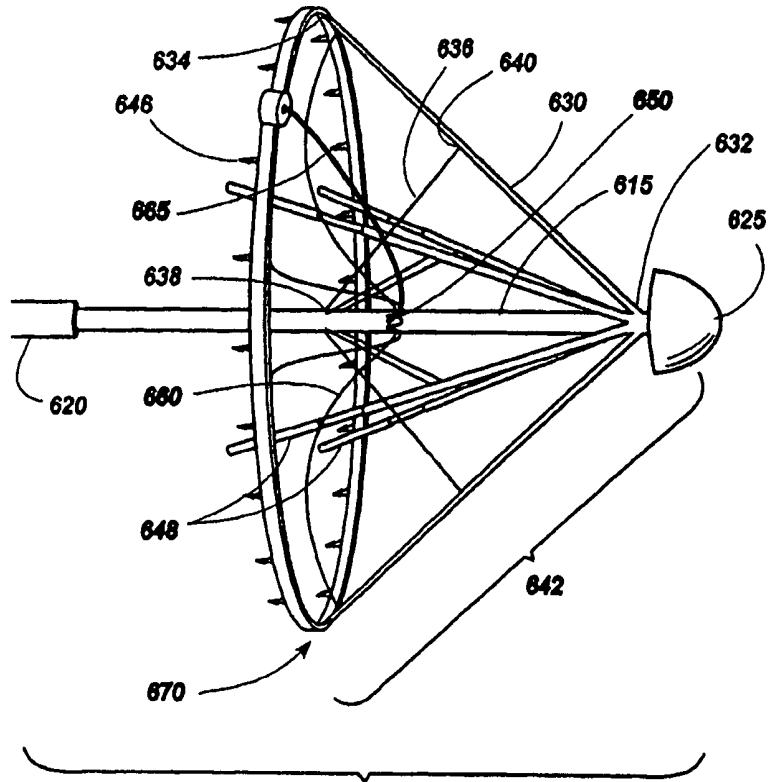

Fig. 12

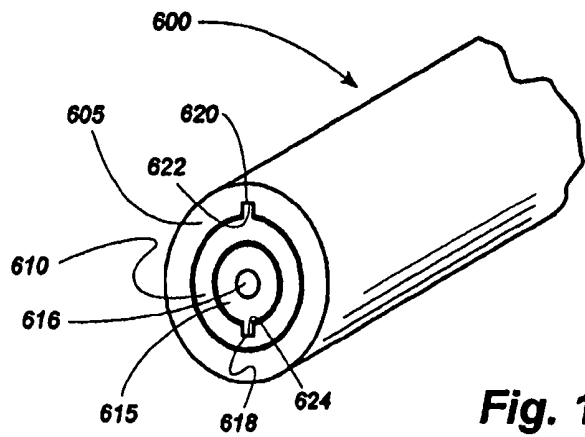

Fig. 13

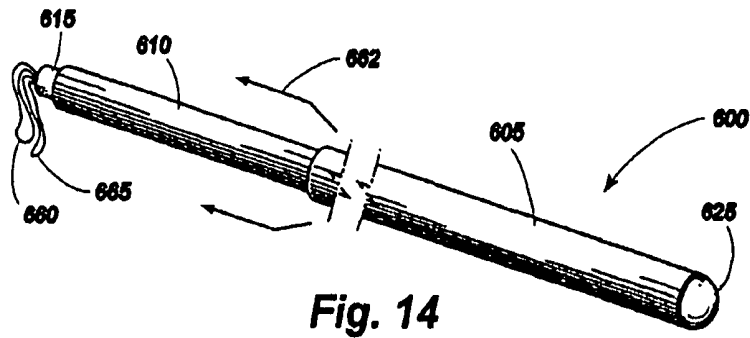

Fig. 14

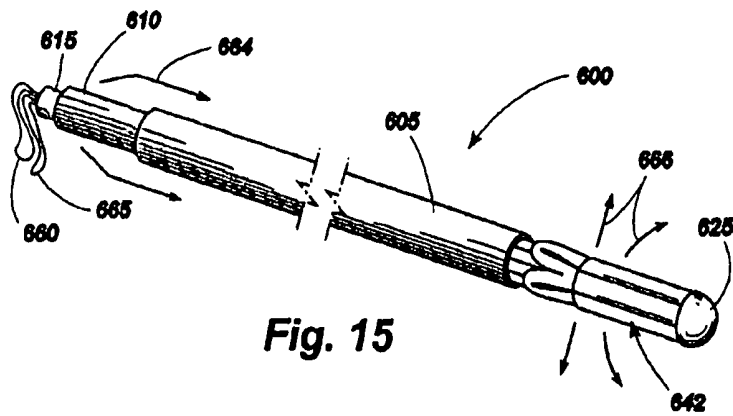

Fig. 15

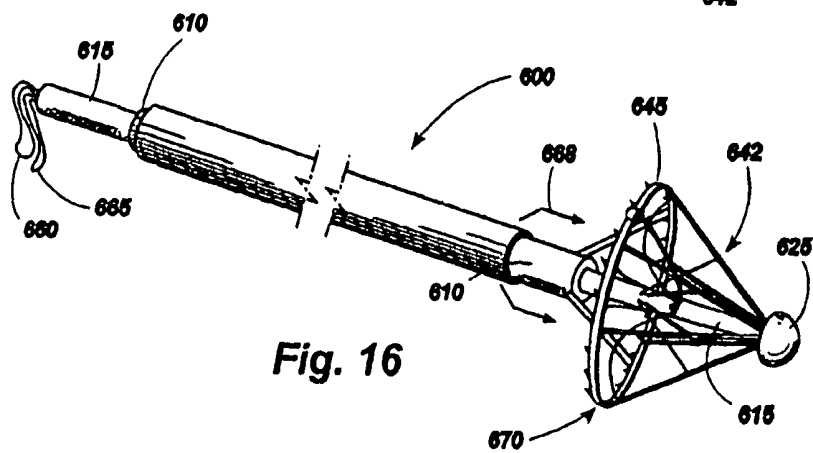

Fig. 16

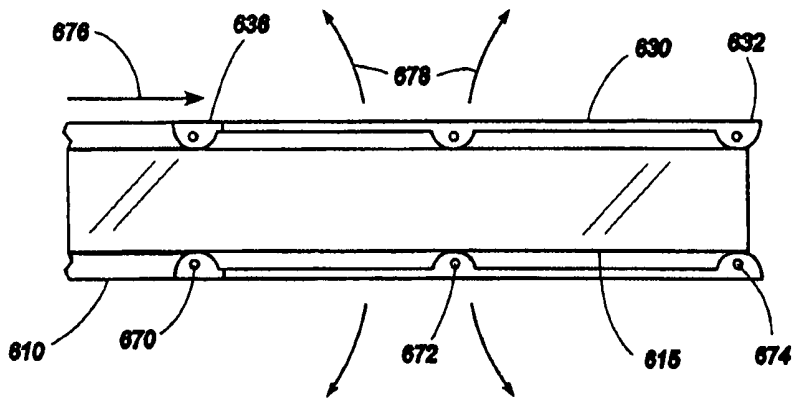

Fig. 17

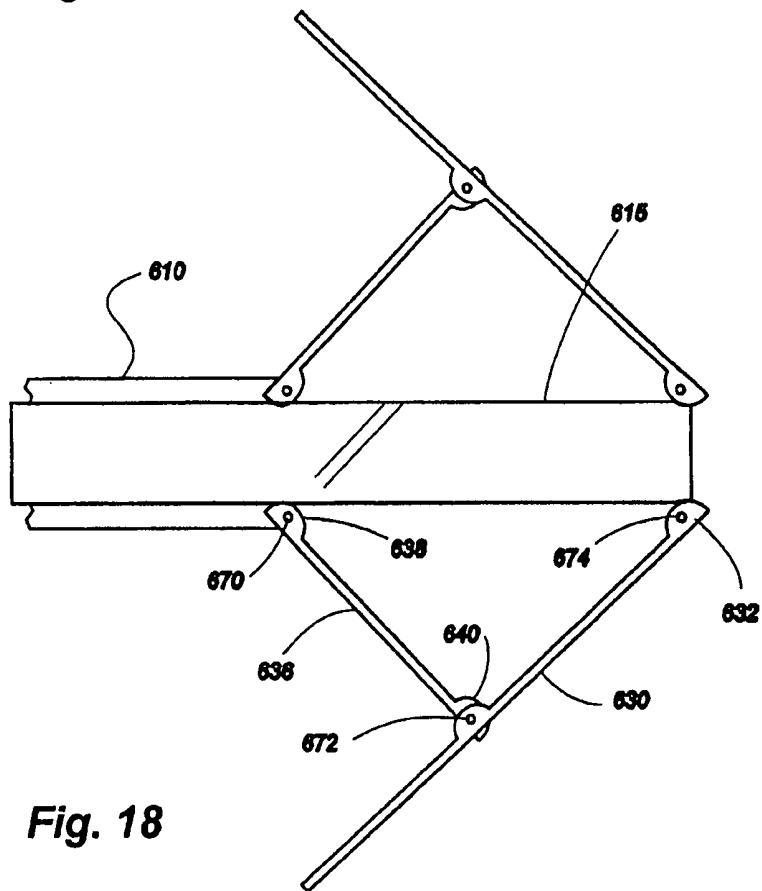
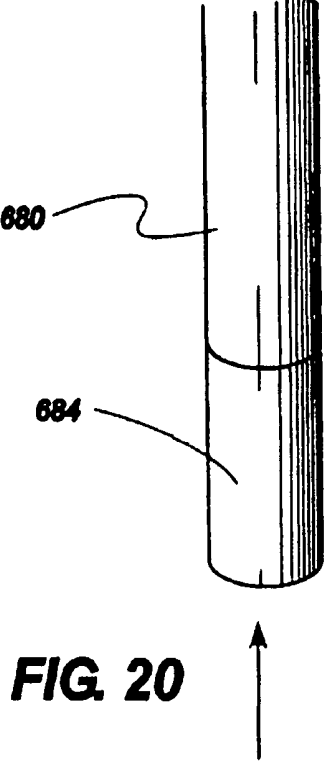
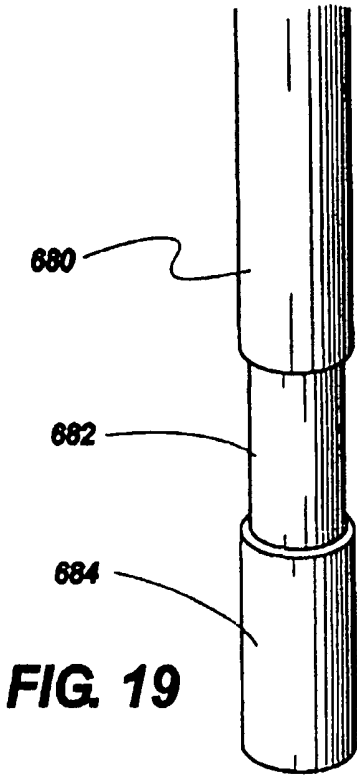
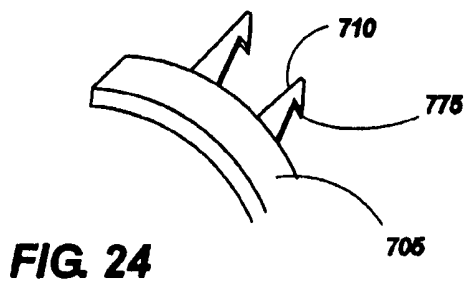
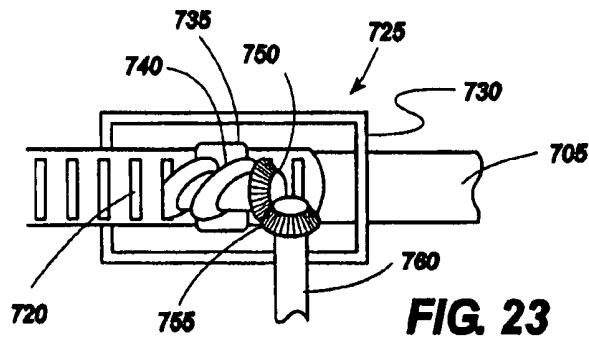
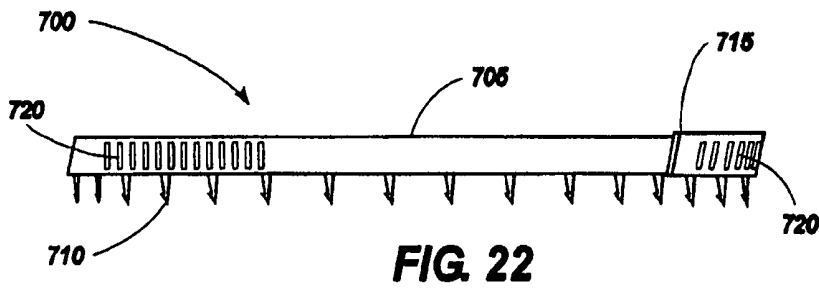
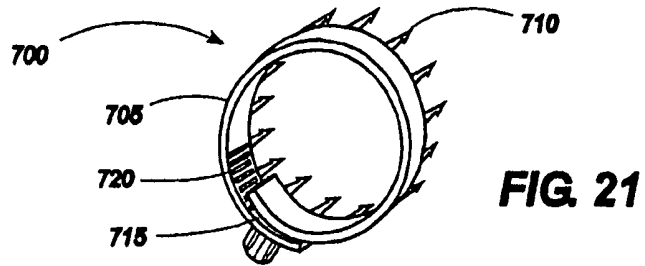

Fig. 18





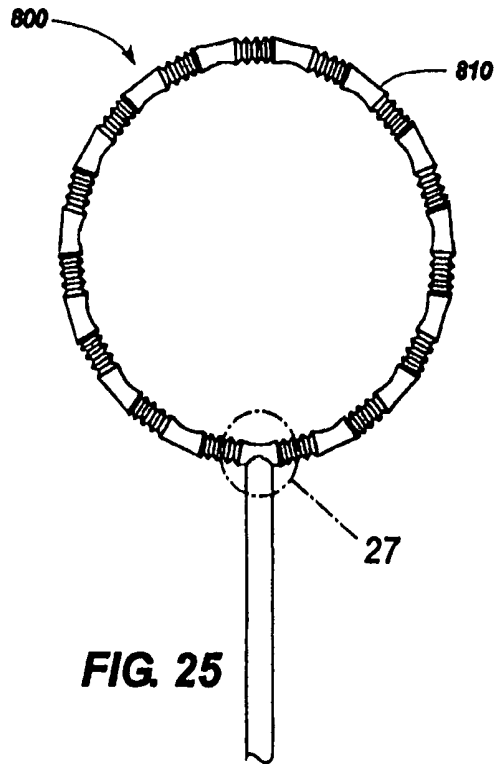

FIG. 25

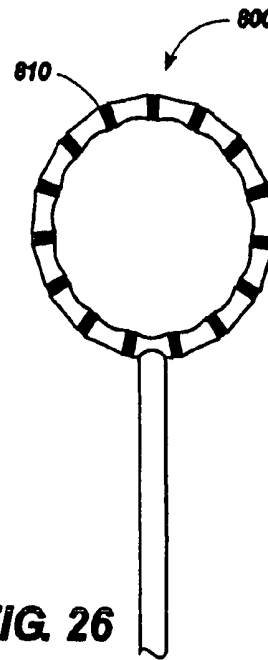

FIG. 26

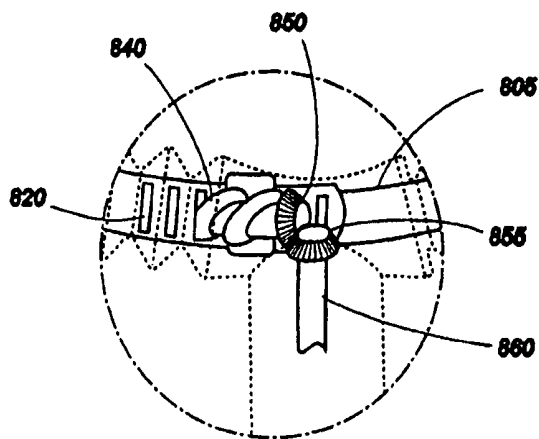
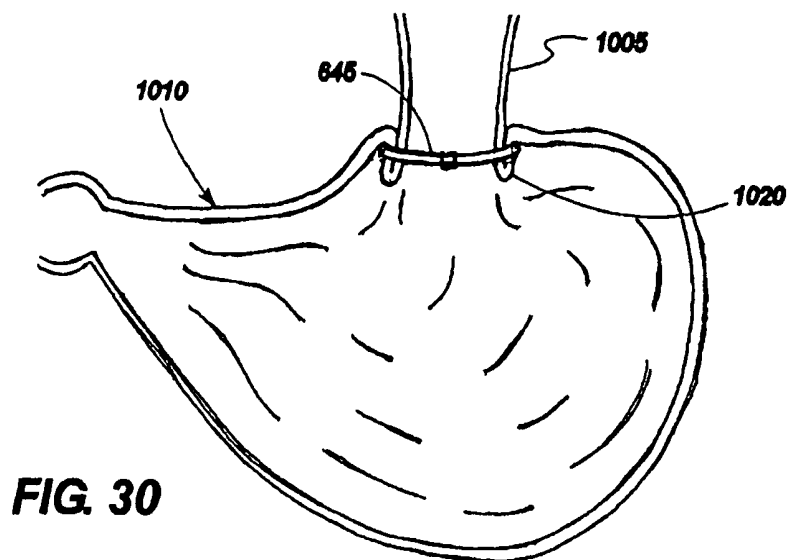
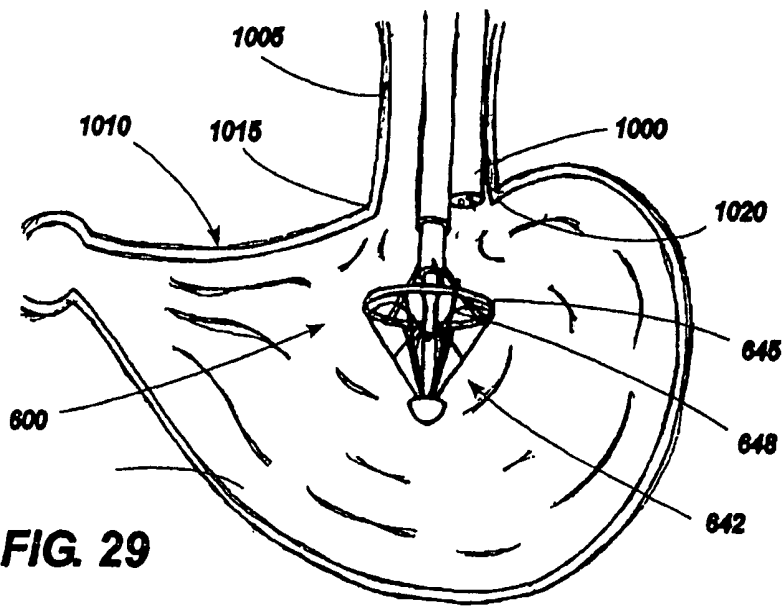

FIG. 27



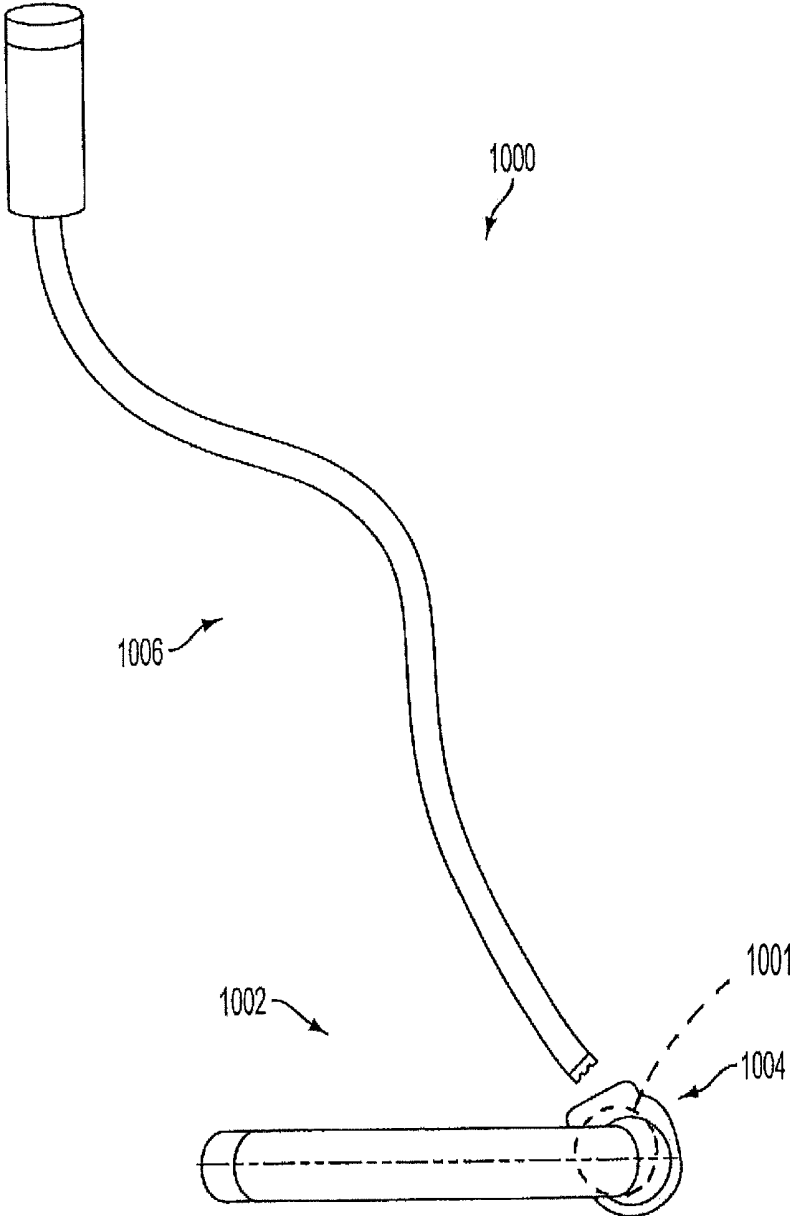

FIG. 31

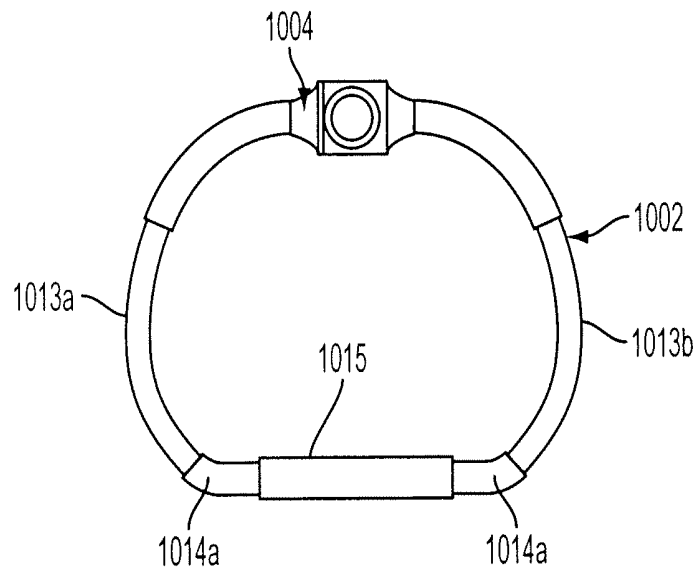

FIG. 32A

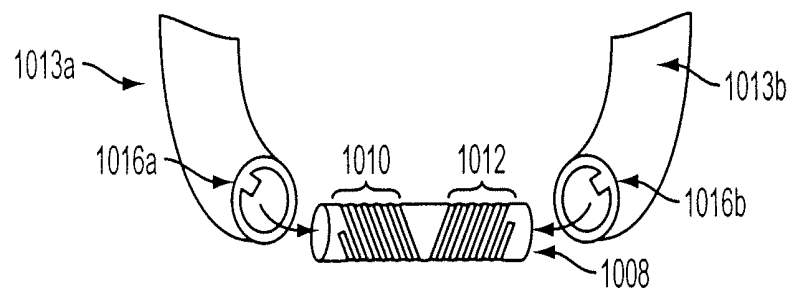

FIG. 32B

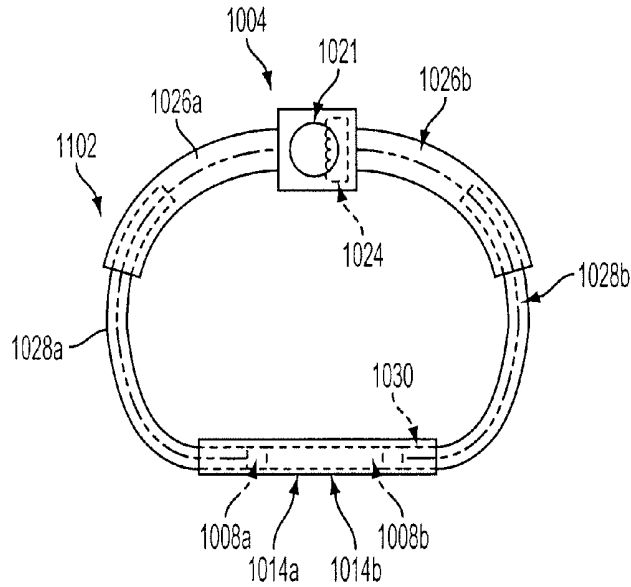

FIG. 33

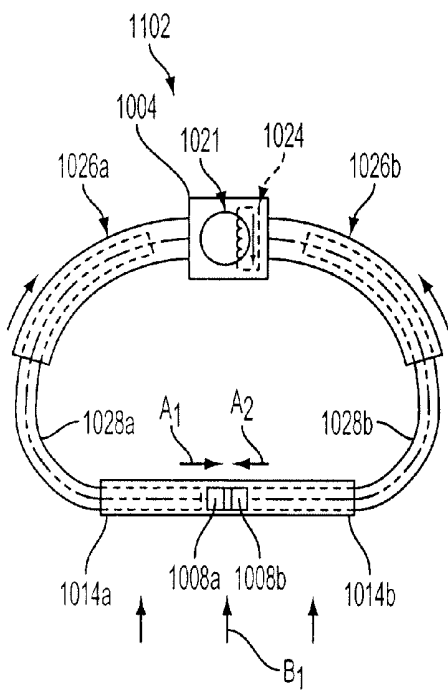

FIG. 34

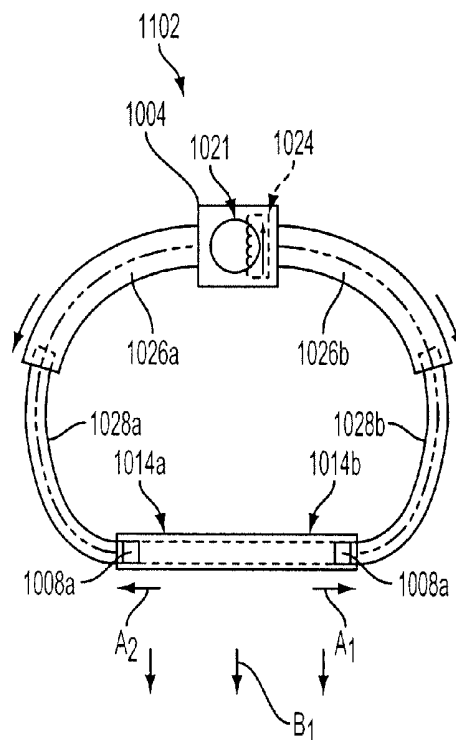

FIG. 35

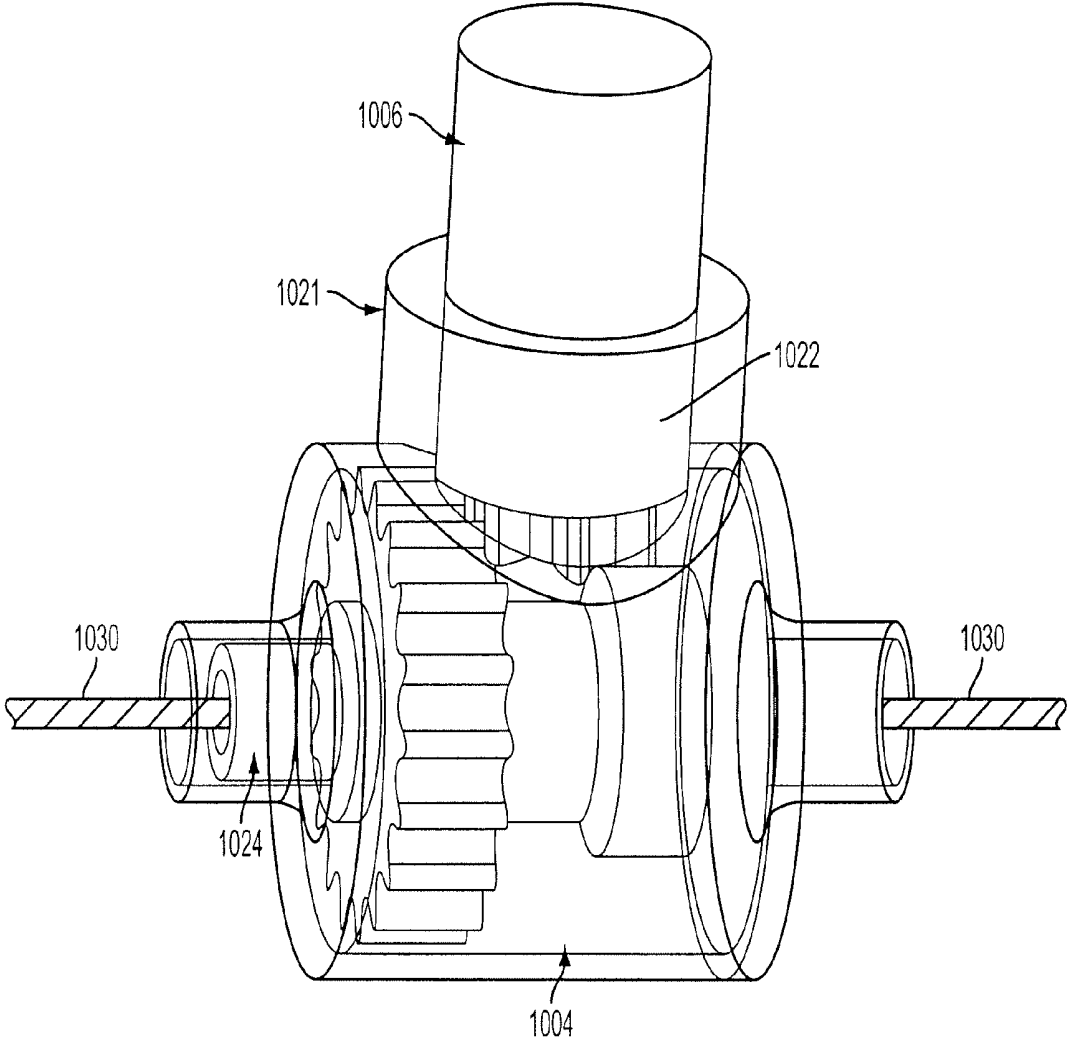

FIG. 36

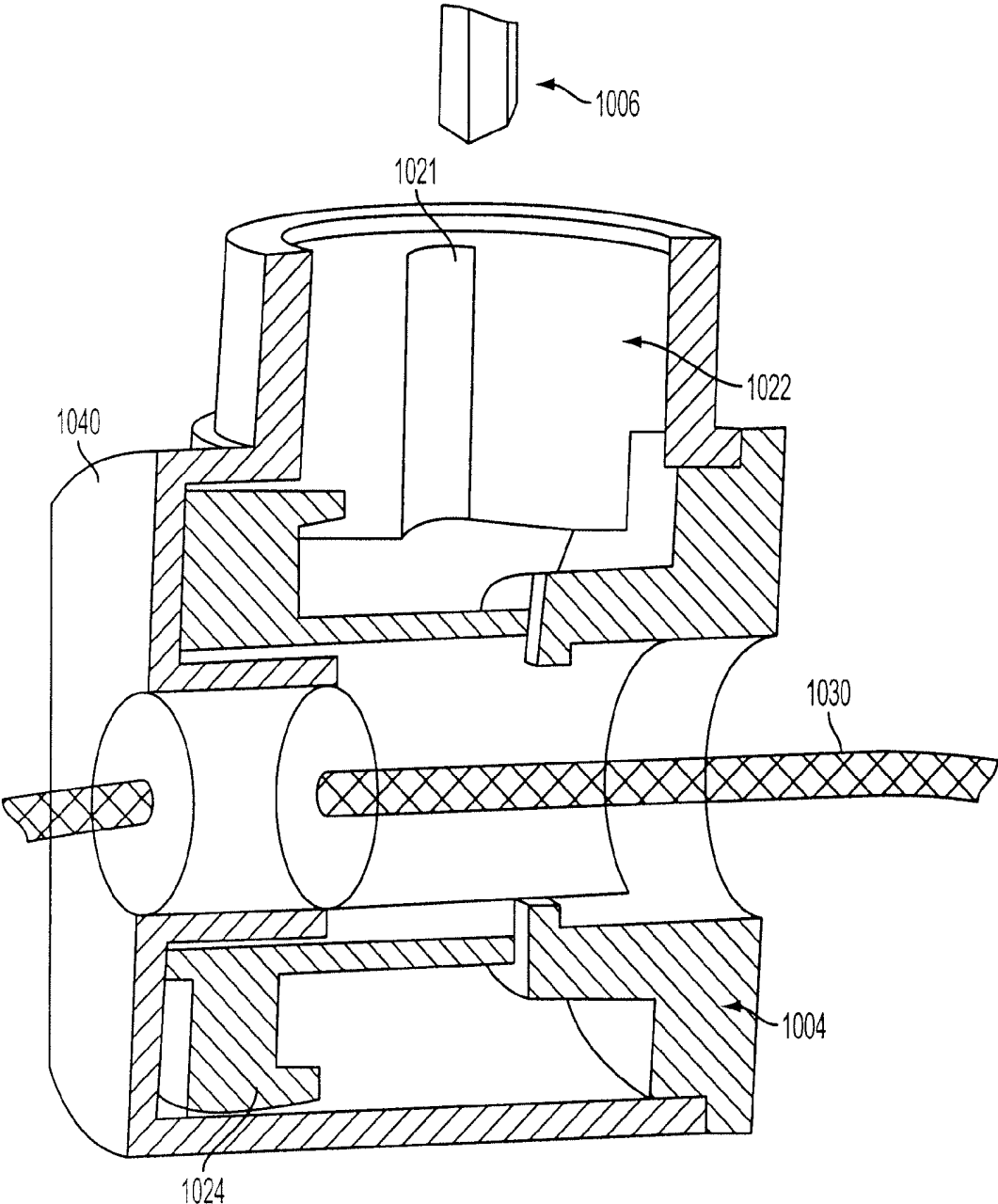

FIG. 37

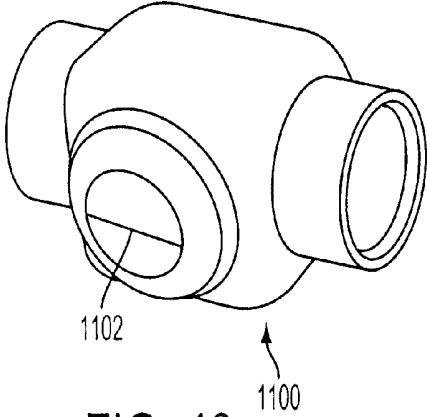

FIG. 40

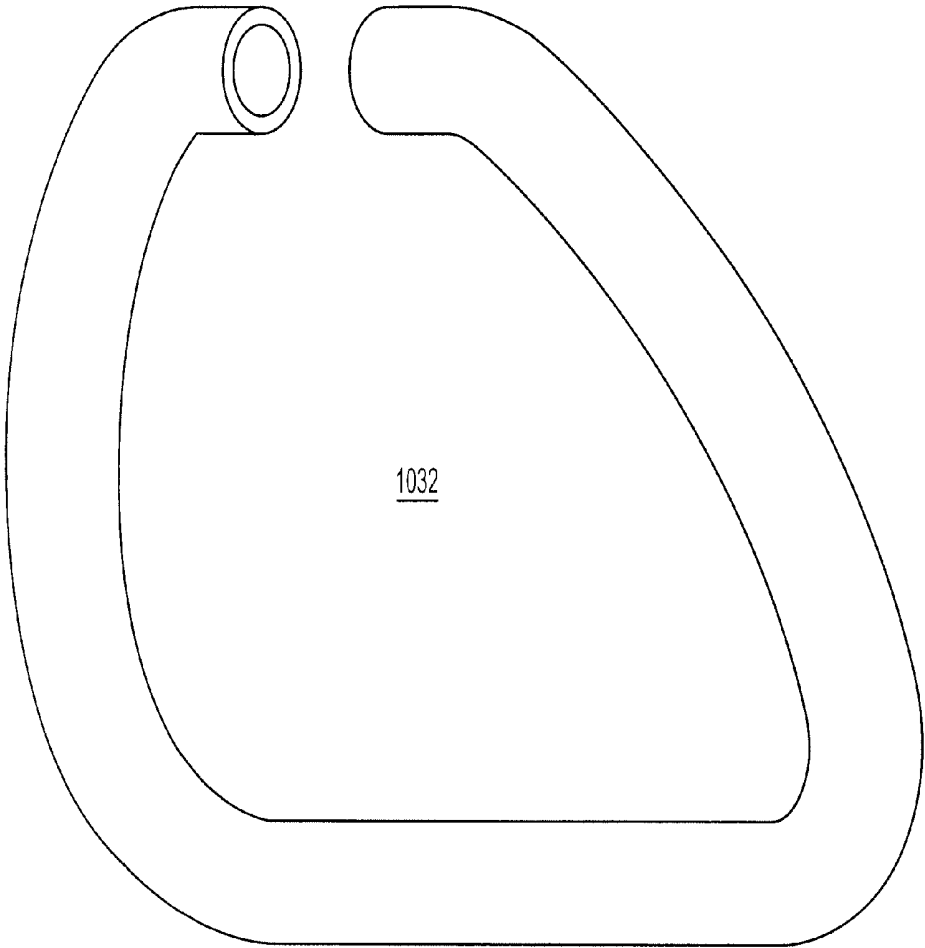

FIG. 38

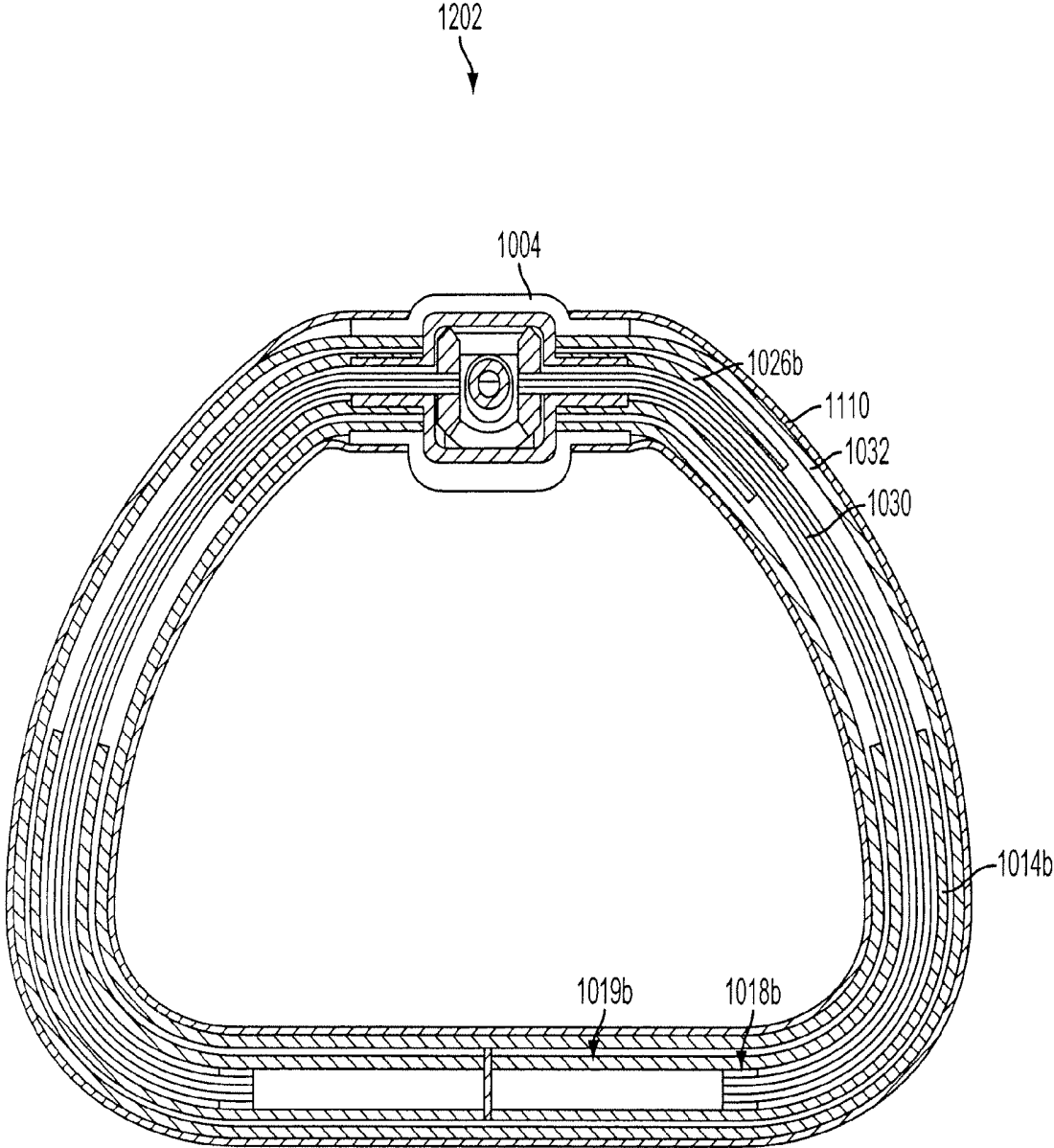

FIG. 39

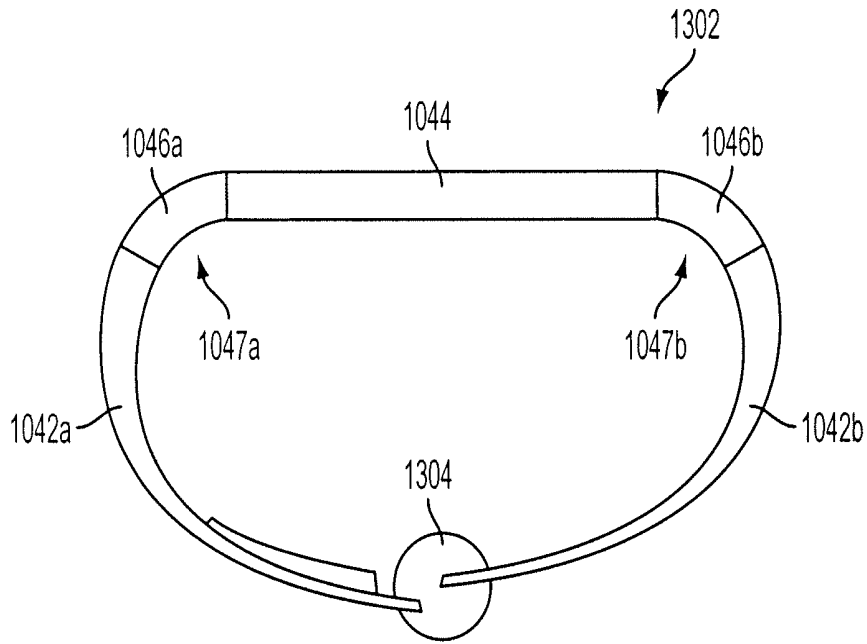

FIG. 41

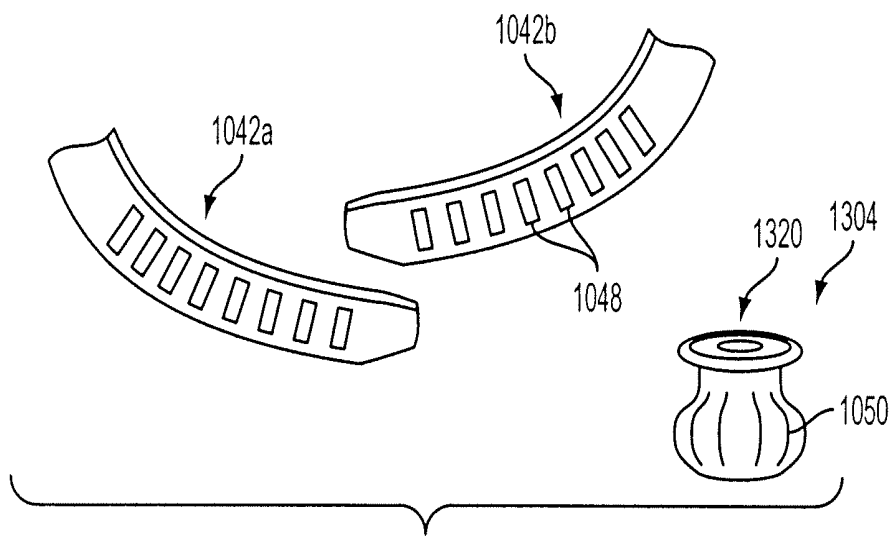

FIG. 42

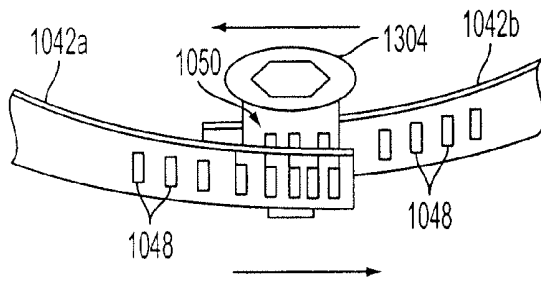

FIG. 43

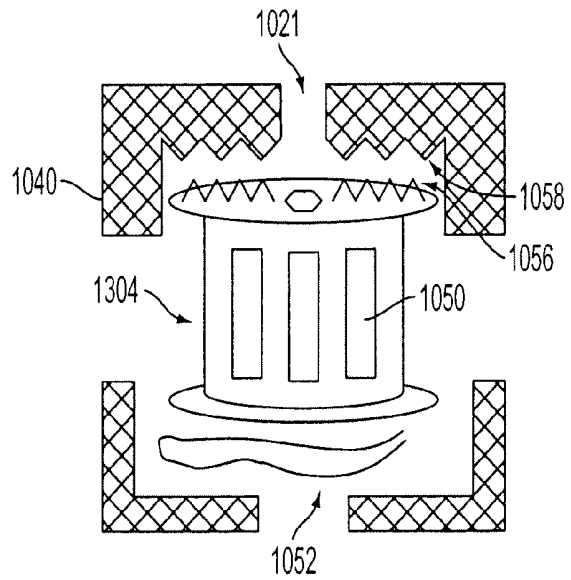

FIG. 44

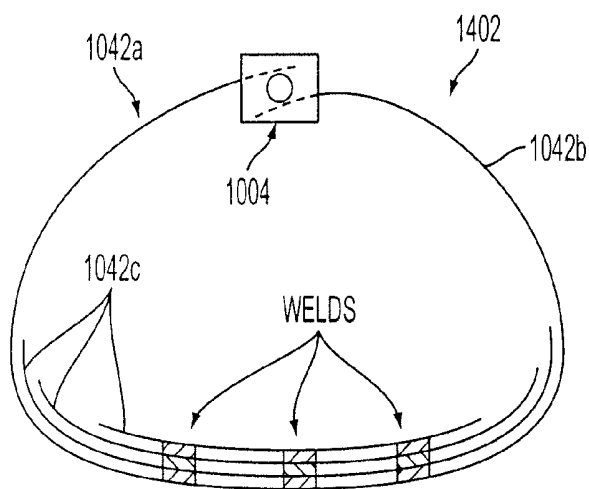

FIG. 45

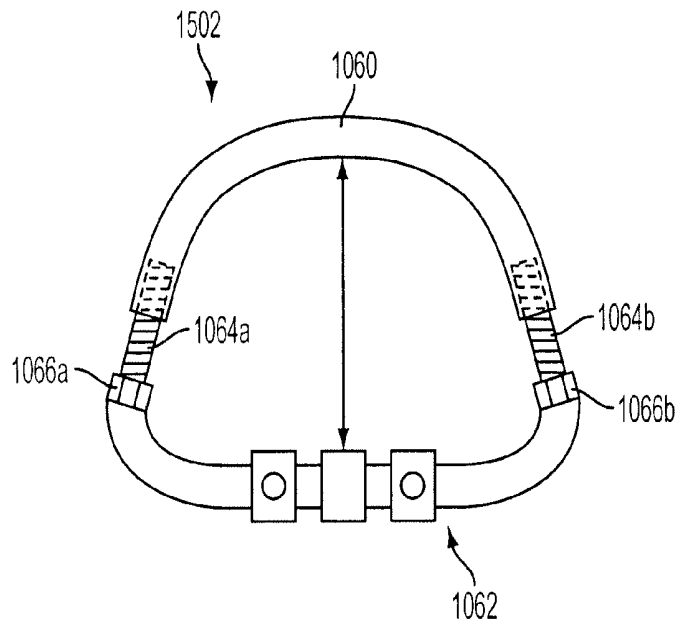

FIG. 46

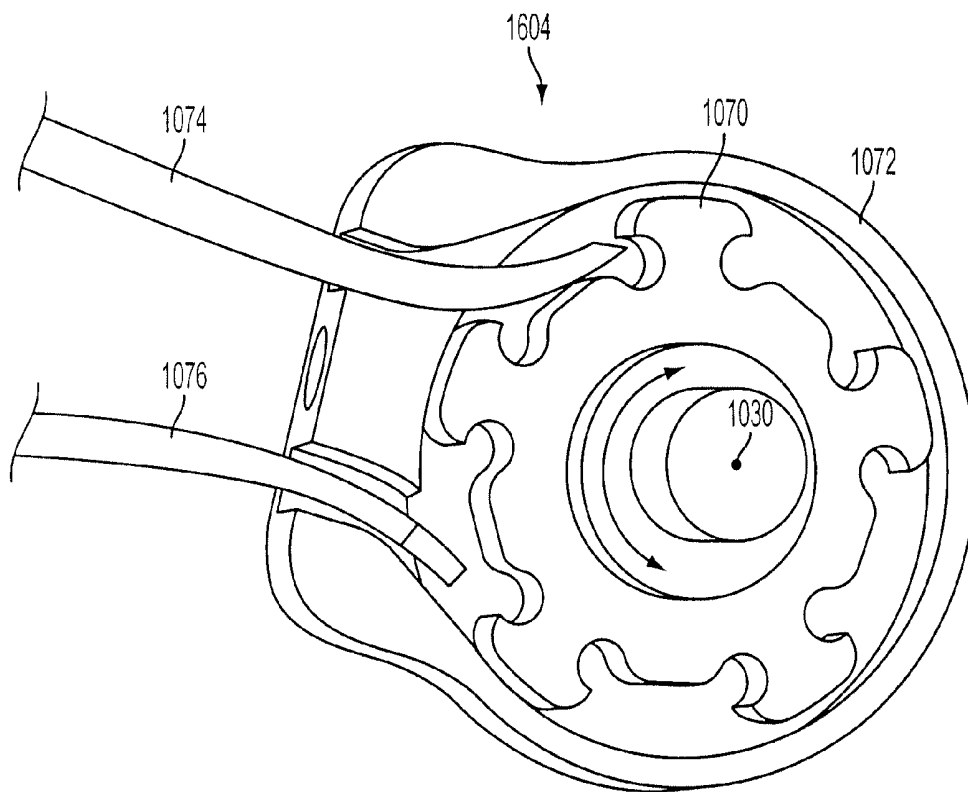

FIG. 47

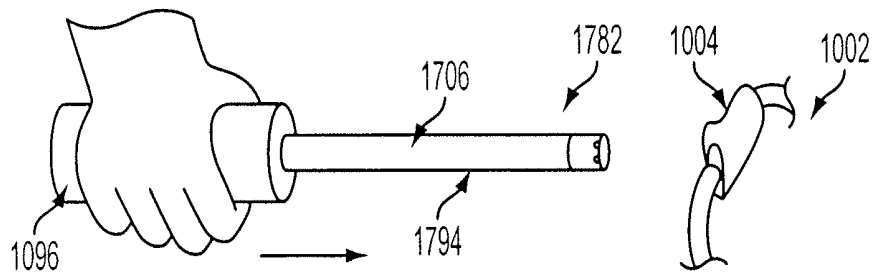

FIG. 48

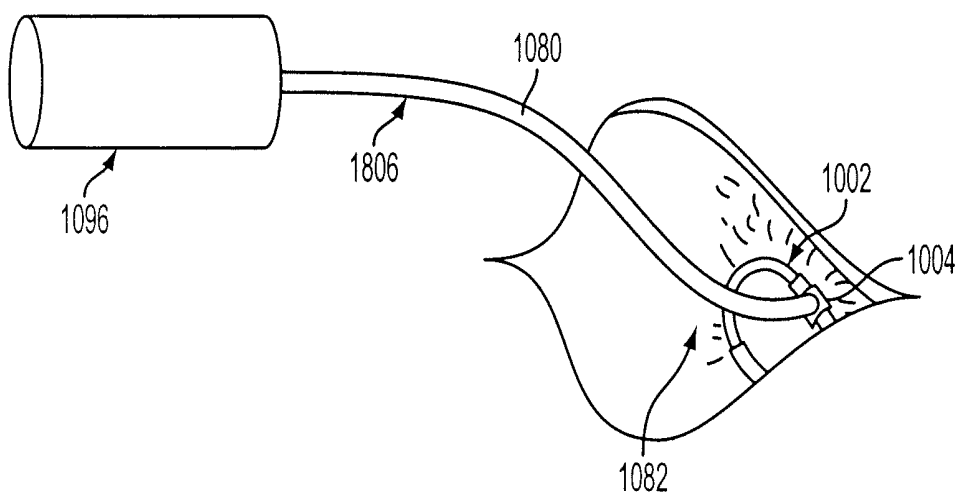

FIG. 49

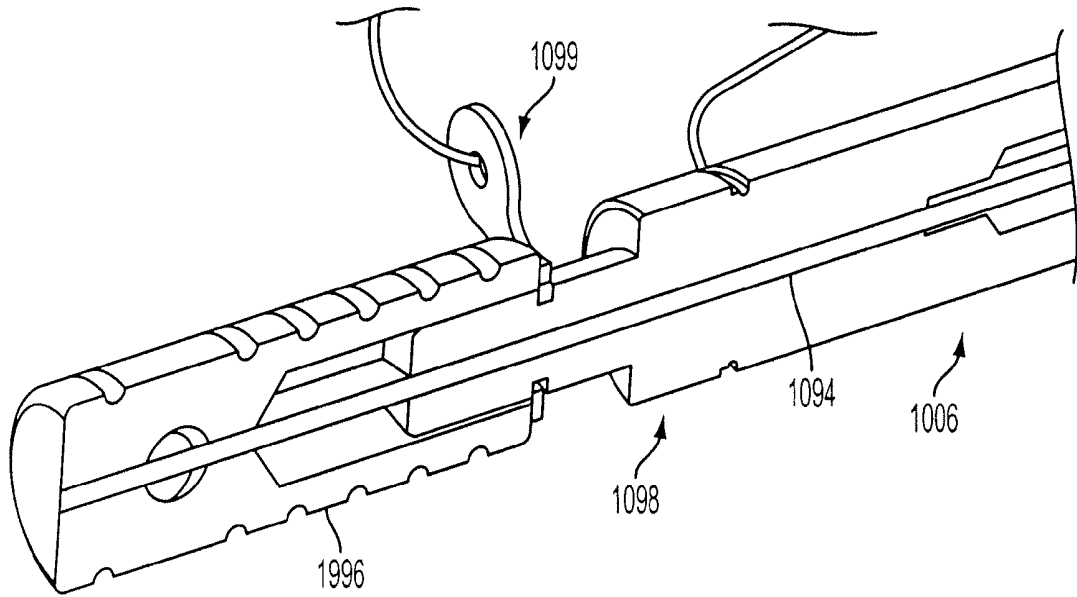

FIG. 50

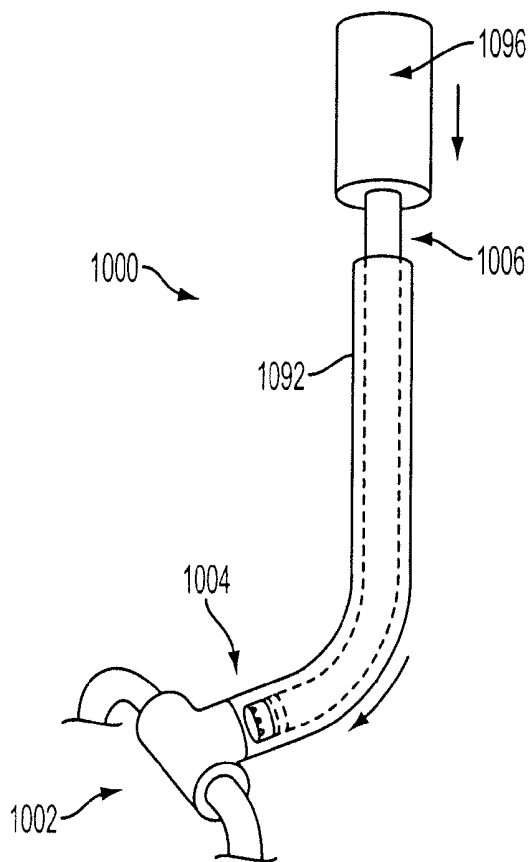

FIG. 51

**IMPLANTABLE DEVICES FOR
CONTROLLING THE SIZE AND SHAPE OF
AN ANATOMICAL STRUCTURE OR LUMEN**

CROSS REFERENCE TO RELATED
APPLICATIONS

This application is a continuation-in-part of U.S. patent application Ser. No. 10/651,840, filed Aug. 29, 2003, now U.S. Pat. No. 7,297,150, which claims priority under 35 U.S.C. § 119(e) from U.S. Provisional Patent Application No. 60/406,841 filed Aug. 29, 2002; U.S. Provisional Patent Application No. 60/444,005, filed Jan. 31, 2003; U.S. Provisional Patent Application No. 60/447,383, filed Feb. 14, 2003; and U.S. Provisional Patent Application No. 60/462,435, filed Apr. 12, 2003; all of which are incorporated herein by reference. This application also claims priority under 35 U.S.C. § 119(e) from U.S. Provisional Patent Application No. 60/801,861, filed on May 19, 2006, which is also incorporated herein by reference.

STATEMENT REGARDING SPONSORED
RESEARCH OR DEVELOPMENT

Not Applicable.

REFERENCE TO SEQUENCE LISTING

Not Applicable.

BACKGROUND OF THE INVENTION

1. Field of the Invention

This invention relates generally to implantable devices for controlling at least one of shape and size of an anatomic structure or lumen.

2. Description of Related Art

There is often a need to reduce the internal circumference of an orifice or other open anatomic structure to narrow or increase the size of the orifice or opening to achieve a desired physiologic effect. Often, such surgical procedures require interruption in the normal physiologic flow of blood, other physiologic fluids, or other structural contents through the orifice or structure. The exact amount of the narrowing or widening required for the desired effect often cannot be fully appreciated until physiologic flow through the orifice or structure is resumed. It would be advantageous, therefore, to have an adjustable means of achieving the narrowing or widening effect, such that the degree of narrowing or widening could be changed after its implantation, and after the resumption of normal flow in situ.

One example of a dysfunction within an anatomic lumen is in the area of cardiac surgery, and specifically valvular repair. Approximately one million open heart surgical procedures are now performed annually in the United States, and twenty percent of these operations are related to cardiac valves.

The field of cardiac surgery was previously transformed by the introduction of the pump oxygenator, which allowed open heart surgery to be performed. Valvular heart surgery was made possible by the further introduction of the mechanical ball-valve prosthesis, and many modifications and different forms of prosthetic heart valves have since been developed. However, the ideal prosthetic valve has yet to be designed, which attests to the elegant form and function of the native heart valve.

As a result of the difficulties in engineering a perfect prosthetic heart valve, there has been growing interest in repairing

a patient's native valve. These efforts have documented equal long-term durability to the use of mechanical prostheses, with added benefits of better ventricular performance due to preservation of the subvalvular mechanisms and obviation of the need for chronic anticoagulation. Mitral valve repair has become one of the most rapidly growing areas in adult cardiac surgery today.

Mitral valve disease can be subdivided into intrinsic valve disturbances and pathology extrinsic to the mitral valve ultimately affecting valvular function. Although these subdivisions exist, many of the repair techniques and overall operative approaches are similar in the various pathologies that exist.

Historically, most valvular pathology was secondary to rheumatic heart disease, a result of a streptococcal infection, most commonly affecting the mitral valve, followed by the aortic valve, and least often the pulmonic valve. The results of the infectious process are mitral stenosis and aortic stenosis, followed by mitral insufficiency and aortic insufficiency. With the advent of better antibiotic therapies, the incidence of rheumatic heart disease is on the decline, and accounts for a smaller percentage of valvular heart conditions in the developed world of the present day. Commissurotomy of rheumatic mitral stenosis was an early example of commonly practiced mitral valve repair outside of the realm of congenital heart defects. However, the repairs of rheumatic insufficient valves have not met with good results due to the underlying valve pathology and the progression of disease.

Most mitral valve disease other than rheumatic results in valvular insufficiency that is generally amenable to repair. Chordae rupture is a common cause of mitral insufficiency, resulting in a focal area of regurgitation. Classically, one of the first successful and accepted surgical repairs was for ruptured chordae of the posterior mitral leaflet. The technical feasibility of this repair, its reproducible good results, and its long-term durability led the pioneer surgeons in the field of mitral valve repair to attempt repairs of other valve pathologies.

Mitral valve prolapse is a fairly common condition that leads over time to valvular insufficiency. In this disease, the plane of coaptation of the anterior and posterior leaflets is "atrialized" relative to a normal valve. This problem may readily be repaired by restoring the plane of coaptation into the ventricle.

The papillary muscles within the left ventricle support the mitral valve and aid in its function. Papillary muscle dysfunction, whether due to infarction or ischemia from coronary artery disease, often leads to mitral insufficiency (commonly referred to as ischemic mitral insufficiency). Within the scope of mitral valve disease, this is the most rapidly growing area for valve repair. Historically, only patients with severe mitral insufficiency were repaired or replaced, but there is increasing support in the surgical literature to support valve repair in patients with moderate insufficiency that is attributable to ischemic mitral insufficiency. Early aggressive valve repair in this patient population has been shown to increase survival and improve long-term ventricular function.

In addition, in patients with dilated cardiomyopathy the etiology of mitral insufficiency is the lack of coaptation of the valve leaflets from a dilated ventricle. The resultant regurgitation is due to the lack of coaptation of the leaflets. There is a growing trend to repair these valves, thereby repairing the insufficiency and restoring ventricular geometry, thus improving overall ventricular function.

Two essential features of mitral valve repair are to fix primary valvular pathology (if present) and to support the annulus or reduce the annular dimension using a prosthesis

that is commonly in the form of a ring or band. The problem encountered in mitral valve repair is the surgeon's inability to fully assess the effectiveness of the repair until the heart has been fully closed, and the patient is weaned off cardiopulmonary bypass. Once this has been achieved, valvular function can be assessed in the operating room using transesophageal echocardiography (TEE). If significant residual valvular insufficiency is then documented, the surgeon must re-arrest the heart, re-open the heart, and then re-repair or replace the valve. This increases overall operative, anesthesia, and bypass times, and therefore increases the overall operative risks.

If the prosthesis used to reduce the annulus is larger than the ideal size, mitral insufficiency may persist. If the prosthesis is too small, mitral stenosis may result.

The need exists, therefore, for an adjustable prosthesis that would allow a surgeon to adjust the annular dimension in situ in a beating heart under TEE guidance or other diagnostic modalities to achieve optimal valvular sufficiency and function.

Cardiac surgery is but one example of a setting in which adjustment of the annular dimension of an anatomic orifice in situ would be desirable. Another example is in the field of gastrointestinal surgery, where the Nissen fundoplication procedure has long been used to narrow the gastro-esophageal junction for relief of gastric reflux into the esophagus. In this setting, a surgeon is conventionally faced with the tension between creating sufficient narrowing to achieve reflux control, but avoiding excessive narrowing that may interfere with the passage of nutrient contents from the esophagus into the stomach. Again, it would be desirable to have a method and apparatus by which the extent to which the gastro-esophageal junction is narrowed could be adjusted in situ to achieve optimal balance between these two competing interests.

Aside from the problem of adjusting the internal circumference of body passages in situ, there is often a need in medicine and surgery to place a prosthetic implant at a desired recipient anatomic site. For example, existing methods proposed for percutaneous mitral repair include approaches through either the coronary sinus or percutaneous attempts to affix the anterior mitral leaflet to the posterior mitral leaflet. Significant clinical and logistical problems attend both of these existing technologies. In the case of the coronary sinus procedures, percutaneous access to the coronary sinus is technically difficult and time consuming to achieve, with procedures which may require several hours to properly access the coronary sinus. Moreover, these procedures employ incomplete annular rings, which compromise their physiologic effect. Such procedures are typically not effective for improving mitral regurgitation by more than one clinical grade. Finally, coronary sinus procedures carry the potentially disastrous risks of either fatal tears or catastrophic thrombosis of the coronary sinus.

Similarly, percutaneous procedures which employ sutures, clips, or other devices to affix the anterior mitral leaflets to the posterior mitral leaflets also have limited reparative capabilities. Such procedures are also typically ineffective in providing a complete repair of mitral regurgitation. Furthermore, surgical experience indicates that such methods are not durable, with likely separation of the affixed valve leaflets. These procedures also fail to address the pathophysiology of the dilated mitral annulus in ischemic heart disease. As a result of the residual anatomic pathology, no ventricular remodeling or improved ventricular function is likely with these procedures.

The need exists, therefore, for a delivery system and methods for its use that would avoid the need for open surgery in such exemplary circumstances, and allow delivery, placement, and adjustment of a prosthetic implant to reduce the diameter of such a mitral annulus in a percutaneous or other minimally invasive procedure, while still achieving clinical and physiologic results that are at least the equivalent of the yields of the best open surgical procedures for these same problems.

The preceding cardiac applications are only examples of some applications according to the present invention. Another exemplary application anticipated by the present invention is in the field of gastrointestinal surgery, where the aforementioned Nissen fundoplication procedure has long been used to narrow the gastro-esophageal junction for relief of gastric reflux into the esophagus. In this setting, a surgeon is conventionally faced with the tension between creating sufficient narrowing to achieve reflux control, but avoiding excessive narrowing that may interfere with the passage of nutrient contents from the esophagus into the stomach. Additionally, "gas bloat" may cause the inability to belch, a common complication of over-narrowing of the GE junction. An adjustable prosthetic implant according to the present invention could allow in situ adjustment in such a setting under physiologic assessment after primary surgical closure.

Such an adjustable prosthetic implant according to the present invention could be placed endoscopically, percutaneously, or with an endoscope placed within a body cavity or organ, or by trans-abdominal or trans-thoracic approaches. In addition, such an adjustable prosthetic implant according to the present invention could be coupled with an adjustment means capable of being placed in the subcutaneous or other anatomic tissues within the body, such that remote adjustments could be made to the implant during physiologic function of the implant. This adjustment means can also be contained within the implant and adjusted remotely, i.e. remote control adjustment. Such an adjustment means might be capable of removal from the body, or might be retained within the body indefinitely for later adjustment.

The present invention and the methods for its use anticipate many alternate embodiments in other potential applications in the broad fields of medicine and surgery. Among the other potential applications anticipated according to the present invention are adjustable implants for use in the treatment of morbid obesity, urinary incontinence, anastomotic strictures, arterial stenosis, urinary incontinence, cervical incompetence, ductal strictures, and anal incontinence. The preceding discussions are intended to be exemplary embodiments according to the present invention and should not be construed to limit the present invention and the methods for its use in any way.

SUMMARY OF THE INVENTION

An object of the present invention is to provide an implantable device for controlling at least one of shape and size of an anatomical structure or lumen.

These and other objects of the present invention are achieved in an implantable device for controlling at least one of shape and size of an anatomical structure or lumen. An implantable device is provided that has an adjustable member configured to adjust the dimensions of the implantable device. In certain embodiments, a torqueable adjustment tool is configured to provide adjustment of the dimensions of the implantable device for a preferred dimension. In other

embodiments adjustments for a preferred dimension may be accomplished remotely through activation of internal adjustment mechanisms.

In another embodiment of the present invention, an implantable device is provided for controlling at least one of shape and size of an anatomical structure or lumen that includes an implantable device has an adjustable member configured to adjust the dimensions of the implantable device, a particularly a preferred dimension. An adjustment tool is configured to provide adjustment of the dimensions of the implantable device, the adjustment tool providing translated motion through rotation.

In another embodiment of the present invention, an implantable device is provided for controlling at least one of shape and size of an anatomical structure or lumen. An implantable device has an adjustable member configured to adjust the dimensions of the implantable device and includes first and second bands. An adjustment tool is configured to provide adjustment of the dimensions of the implantable device for a preferred dimension.

In still another embodiment of the present invention, an implantable device is provided for controlling at least one of shape and size of an anatomical structure or lumen. An implantable device has an adjustable member configured to adjust the dimensions of the implantable device. The implantable device has an anterior portion, a posterior portion and dual threads that provide preferential adjustment of one side or the other of the implantable device. An adjustment tool is configured to provide adjustment of the dimensions of the implantable device.

In yet another embodiment of the present invention, an implantable device controls at least one of shape and size of an anatomical structure or lumen. An implantable device has an adjustable member configured to adjust the dimensions of the implantable device. An adjustment tool is configured to provide adjustment of the dimensions of the implantable device. The adjustment tool provides reciprocating action to provide for the adjustment.

In another embodiment of the present invention, an implantable device controls at least one of shape and size of an anatomical structure or lumen. An implantable device has an adjustable member configured to adjust the dimensions of the implantable device. An adjustment tool is configured to provide adjustment of the dimensions of the implantable device. The adjustment tool provides both course adjustment and fine adjustment.

Other features and advantages of the present invention will become apparent upon reading the following specification, when taken in conjunction with the drawings and the appended claims.

BRIEF DESCRIPTION OF FIGURES

FIG. 1 is a front view of a first embodiment of an implant for reducing the circumference of an anatomic orifice.

FIG. 2 is a front view of the implant of FIG. 1 secured to the annulus of a mitral valve, with the implant in an expanded position.

FIG. 3 is a front view of the implant of FIG. 1 secured to the annulus of a mitral valve, with the implant in a contracted position to reduced the size of the heart valve opening.

FIG. 4 is a perspective view of a second embodiment of an implant for reducing the circumference of an anatomic orifice, inserted through an open operative cardiac incision and secured around the mitral valve.

FIG. 5 is a perspective view of the implant of FIG. 4, showing the cardiac incision closed, an adjustment tool

extending through the closed incision, and adjustment of the implant possible after the patient has been taken "off pump."

FIG. 6 is a perspective view of a first embodiment of an adjustment means for adjusting the circumference of an implant for reducing the circumference of an anatomic orifice.

FIG. 7 is a right side view of the adjustment means of FIG. 6.

FIG. 8 is a left side view of the adjustment means of FIG. 6.

FIG. 9 is a right side view of a second embodiment of an adjustment means for adjusting the circumference of an implant for reducing the circumference of an anatomic orifice.

FIG. 10 is a perspective view of a first alternate embodiment of an attachment means for the implant of FIG. 1.

FIG. 11 is a perspective view of a second alternate embodiment of an attachment means for the implant of FIG. 1.

FIG. 12 is a perspective view of a third embodiment of an implant for reducing the circumference of an anatomic orifice.

FIG. 13 is a perspective view of one end of the implant of FIG. 12 showing an optional keyed relationship between three coaxial cannulae to prevent relative rotation between the three components.

FIG. 14 is a perspective view of the implant of FIG. 12 showing the outer cannula extended to cover the implant.

FIG. 15 is a perspective view of the implant of FIG. 12 showing the outer cannula retracted to expose the implant.

FIG. 16 is a perspective view of the implant of FIG. 12 showing the middle cannula extended to unfold the implant.

FIGS. 17 and 18 are schematic views illustrating how extension of the middle cannula causes the implant to unfold, where FIG. 17 shows the implant in the folded position, and FIG. 18 shows the implant in the unfolded position.

FIG. 19 is a perspective view of the lower end of a touchdown sensor of the implant of FIG. 12, showing the sensor in an uncompressed condition.

FIG. 20 is a perspective view of the lower end of the touchdown sensor of FIG. 19, showing the sensor in a compressed condition.

FIG. 21 is a perspective end view of a fourth embodiment of an implant for reducing the circumference of an anatomic orifice.

FIG. 22 is a side view of the implant of FIG. 21 with the implant opened up to show its full length.

FIG. 23 is a side view of the adjustment mechanism of the implant of FIG. 21.

FIG. 24 is a close-up view of two of the retention barbs of the implant of FIG. 21.

FIG. 25 is a front view of a fifth embodiment of an implant for reducing the circumference of an anatomic orifice, with the implant shown in its expanded configuration.

FIG. 26 is a front view of the implant of FIG. 25, with the implant shown in its contracted configuration.

FIG. 27 is an enlarged view of the area indicated by the circle 27 in FIG. 25, with the outer body removed to show interior detail.

FIG. 28 is a schematic view showing the implant of FIG. 12 anatomically positioned at the mitral annulus in a heart with the implant in a fully expanded state.

FIG. 29 is a schematic view showing the implant of FIG. 12 anatomically positioned at the gastroesophageal opening with the implant in a fully expanded state.

FIG. 30 is a schematic view showing the implant of FIG. 29 implanted to reduce the circumference of the gastroesophageal opening.

FIG. 31 is a schematic view of an embodiment of an implantable device of the present invention.

FIG. 32A is a schematic view of another embodiment of an implantable device of the present invention.

FIG. 32B is a schematic view of a threaded member in an embodiment of an implantable device of the present invention.

FIG. 33 is a schematic view of an embodiment of an implantable device of the present invention with an outer tubing and an inner tubing in a relative first position.

FIG. 34 is a schematic view of an embodiment of an implantable device of the present invention with an outer tubing and an inner tubing in a relative second position.

FIG. 35 is a schematic view of an embodiment of an implantable device of the present invention with an outer tubing and an inner tubing in a relative third position.

FIG. 36 is a schematic view of an embodiment of an adjustable member of the present invention, with the distal tip of the adjustment tool coupled to the adjustment member.

FIG. 37 is a schematic view of an embodiment of an adjustment member of the present invention having an integrated pinion gear.

FIG. 38 is a schematic view of an embodiment of a flexible tube cover for an implant device.

FIG. 39 is a cross-section view of an assembled embodiment of an adjustable implant device.

FIG. 40 is a schematic view of an embodiment of a seal jacket for an adjustable member.

FIG. 41 is a schematic view of an embodiment of an adjustment band in the implantable member of the present invention.

FIG. 42 is a disassembled schematic view of part of the adjustment band and adjustment member of FIG. 41.

FIG. 43 is an assembled view of the adjustment band and adjustment member of FIG. 42.

FIG. 44 is a schematic view of an embodiment of the gearbox for the adjustment band of FIG. 41.

FIG. 45 is a schematic view of an embodiment of the implantable device of the present invention with a sliding band that can be opened and closed to effect a preferential shape change.

FIG. 46 is a schematic view of an embodiment of the implantable device of the present invention with two adjustable screws used to achieve different pulling rates.

FIG. 47 is a schematic view of an embodiment of the implantable device of the present invention with reciprocating motion and a clover gear.

FIG. 48 is a schematic view of an embodiment of the implantable device system of the present invention with an adjustment tool having high column strength and stiffness.

FIG. 49 is a schematic view of an embodiment of the implantable device of the present invention shown in vivo with an adjustment tool having reduced column stiffness.

FIG. 50 is a cut-away view of an embodiment of the proximal portion of an adjustment tool.

FIG. 51 is a schematic view of an embodiment of the implantable device of the present invention with an articulated shape.

DETAILED DESCRIPTION OF THE INVENTION

Referring now to the drawings, in which like numerals indicate like elements throughout the several views, an exemplary implant 10 comprising an implant body 15 is shown in FIG. 1. The implant body may be provided in a shape and size determined by the anatomic needs of an intended native recipient anatomic site within a mammalian patient. Such a

native recipient anatomic site may be, by way of illustration and not by way of limitation, a heart valve, the esophagus near the gastro-esophageal junction, the anus, or other anatomic sites within a mammalian body that are creating dysfunction that might be relieved by an implant capable of changing the size and shape of that site and maintaining a desired size and shape after surgery.

The implant 10 of FIG. 1 comprises a circular implant body 15 which is provided with adjustable corrugated sections 20 alternating with intervening grommet-like attachment means 25 having narrowed intermediate neck portions. As can be seen in FIGS. 2 and 3, the implant body 15 may be secured to the annulus of a heart valve 30 by a fixation means such as a suture 35 secured over or through the attachment means 25. The corrugated sections 20 fold and unfold as the circumference of the implant body 15 shortens or lengthens. Adjustment of the implant 10 in situ may decrease the overall size of the heart valve 30, increasing the coaptation of the valve leaflets 40, and changing the configuration from that shown in FIG. 2 to that shown in FIG. 3.

An additional exemplary embodiment 100 of the present invention is shown in FIGS. 4 and 5, with an open operative cardiac incision 105 in a heart 110 shown in FIG. 4, and closure of the cardiac incision 105 in FIG. 5. As shown in FIG. 4, the exemplary adjustable implant 100 according to the present invention comprises an implant body 115 with attachment means 120 that allows fixation to the annulus of a mitral valve 125. The exemplary adjustable implant 100 is further provided with an adjustment means 130 that is controlled by an attached or coupled adjustment tool 135. After closure of the myocardial incision 105 in FIG. 5, the adjustment tool 135 remains attached or coupled to the adjustment means 130, so that the size and shape of the implant 100 may further be affected after physiologic flow through the heart 110 is resumed, but with the chest incision still open. Once the desired shape and function are achieved, the adjustment tool 135 may be disengaged from the adjustment means 130 and withdrawn from the myocardial incision 105. In various embodiments according to the present invention, the adjustment means 130 may be configured and placed to allow retention by or re-introduction of the adjustment tool 135 for adjustment following closure of the chest incision.

To use the implant 100 of FIGS. 4 and 5, the physician makes the open operative incision 105 in the heart 110, as shown in FIG. 4, in the conventional manner. The implant 100, mounted at the forward end of adjustment tool 135, is then advanced through the incision 105 and sutured to the annulus of the mitral valve 125. The adjustment tool 135 is then manipulated, e.g., rotated, depending upon the design of the adjustment means 130, to cause the adjustment means to reduce the size of the implant body 115, and hence the underlying mitral valve 125 to which it is sutured, to an approximate size. The myocardial incision 105 can now be closed, as shown in FIG. 5, leaving the adjustment tool extending through the incision for post-operative adjustment.

Once the patient has been taken "off pump" and normal flow of blood through the heart 110 has resumed, but before the chest incision has been closed, further adjustments to the size of the mitral valve 125 can be made by manipulating the adjustment tool 135.

FIGS. 6-8 show an exemplary adjustment means 200 for adjusting the circumference of an annular implant such as the implant 100 previously described. The adjustment means 200 comprises a rack and pinion system in which a first cam 205 with geared teeth 210 and an engagement coupler 215 turns on a first axle 220. In this example, the first cam 205 engages a geared rack 225 on one or more surfaces of a first band 230.

The first band **230** passes between the first cam **205** and a second cam **235** that turns on a second axel **240** that is joined to a second band **245**. As shown in FIG. **8**, the first and second axels **220**, **240** are maintained in suitable spaced-apart relation by means of a bracket **250** formed at the end of the second band **245**.

The adjustment means **200** is preferably set within a hollow annular implant **100** of the type previously described, though it is possible to use the adjustment means in a stand-alone configuration wherein the first and second bands **230**, **245** are opposing ends of the same continuous annular structure. In either event, to adjust the length of an implant comprising the adjustment means **200**, a tool such as a hex wrench engages the engagement coupler **215** on the first cam **205** and rotates the first cam in a counterclockwise direction as shown in FIG. **7**, as indicated by the arrow **255**. Rotation of the first cam **205** causes the teeth **210** to drive the rack **225** to move the first band **230** toward the right, as indicated by the arrow **260** in FIG. **7**. This movement of the first band tightens the circumference of the annular implant. If the physician inadvertently adjusts the implant too tight, reversing direction of the engagement coupler **215** will loosen the implant.

In various embodiments according to the present invention, the first and second bands **230**, **245** may be separate structures, or they may be opposing ends of the same continuous structure. In such an embodiment, when motion is imparted to the engagement coupler **215**, the first cam **205** is rotated, causing the geared teeth **210** to engage the geared rack **225**, and causing the first band **230** to move with respect to the second band **245** to adjust the circumference of an implant.

FIG. **9** shows a somewhat different configuration of an exemplary engagement means **300** according to the present invention, in which there is no engagement coupler, and a bracket **350** is provided on both sides of the cams to maintain the first cam **315** and the second cam **320** in close approximation. In one proposed embodiment, the bracket is designed with close tolerances so as to press the first band **330** closely against the second band **345**, thereby to hold the bands in fixed relative position by friction. In another proposed embodiment, the brackets **350** are fabricated from an elastic material such that the cams **315**, **320** can be spread apart to insert the first band **330** between the cams, whereupon the cams are pulled back together with sufficient force to hold the bands **330**, **345** in fixed relative position by friction. In still another proposed embodiment involving an elastic mounting arrangement between the cams **315**, **320**, the lower edge of the first band **330** and the upper edge of the second band **345** have mating frictional or mechanical surfaces, whereby the cams **315**, **320** can be spread apart to permit relative movement between the bands or released to clamp the bands together in fixed relation.

FIG. **10** shows an exemplary attachment means **400** for an implant according to the present invention. The attachment means **400** could be used, for example, in place of the attachment means **25** of the implant **10**. The attachment means **400** takes the form of a grommet **410** comprising a wall **415** defining a lumen **420** and an attachment surface **425**. Such an attachment means would be used with the implant body extending through the lumen **420** and with fixation devices such as sutures or wires either tied over or affixed through the attachment surface **425**.

FIG. **11** shows another alternate embodiment of an attachment means **500** for an implant according to the present invention. The attachment means **500** could also be used, for example, in place of the attachment means **25** of the implant **10**. FIG. **11** shows an attachment means **500** in the form of a hollow tube or tube segment **510** comprising a wall **515**

defining a lumen **520**, an outer surface **525**, and an attachment tab **530**. Such an attachment means would be used with the implant body extending through the lumen **520** and with fixation devices such as sutures or wires either tied or otherwise affixed over or through the attachment tab **530**. Such fixation devices might be placed through holes **535** provided in the attachment tab **530**. Alternately a solid attachment tab **530** might be provided, and the fixation devices might be passed through the solid tab. Modifications of these attachment means may be used in conjunction with a sutureless attachment system.

FIGS. **12-18** show another embodiment of a percutaneous annuloplasty device according to the present invention, in which an implant/delivery system array **600** includes a housing sheath **605** (not seen in FIG. **12**), an actuating catheter **610** coaxially slidably mounted within the housing sheath **605**, and a core catheter **615** coaxially slidably mounted within the actuating catheter **610**. The core catheter has a central lumen **616** (FIG. **13**). The actuating catheter **610** and core catheter **615** may be round tubular structures, or as shown in FIG. **13**, either or both of the actuating and core catheters may be provided with one or more keyed ridges **618**, **620** respectively to be received by one or more reciprocal slots **622**, **624** within the inner lumen of either the housing sheath **605** or the actuating catheter **610**, respectively. Such keyed ridges **618**, **620** would limit internal rotation of an inner element within an outer element, should such restriction be desirable to maintain control of the inner contents from inadvertent displacement due to undersired rotational motion during use.

The implant/delivery system array **600** includes a distal tip **625** at the forward end of the core catheter **615**. One or more radial implant support arms **630** have their distal ends **632** pivotably or bendably mounted to the core catheter **615** adjacent its distal tip **625**. The proximal ends **634** of the radial implant support arms **630** normally extend along the core catheter **615** but are capable of being displaced outward away from the core catheter.

One or more radial support struts **636** have their proximal ends **638** pivotably or bendably mounted to the distal end of the actuating catheter **610**. The distal end **640** of each radial support strut is **636** pivotably or bendably attached to a midpoint of a corresponding radial implant support arm **630**. As the actuating catheter **610** is advanced with respect to the core catheter **615**, the radial support struts **636** force the radial implant support arms **630** upward and outward in the fashion of an umbrella frame. Thus the actuating catheter **610**, core catheter **615**, radial support struts **636**, and radial support arms **630** in combination form a deployment umbrella **642**.

A prosthetic implant **645** is releasably attached to the proximal ends **634** of the radial implant support arms **630**. Around the periphery of the prosthetic implant **645** and extending proximally therefrom are a plurality of retention barbs **646**. In addition, one or more of the radial implant support arms **630** comprise touchdown sensors **648** whose proximal ends extend proximal to the implant **645**. Extending through the central lumen **616** (FIG. **13**) of the core catheter **615** in the exemplary embodiment **600** and out lateral ports **650** (FIG. **12**) spaced proximally from the distal tip **625** are one or more release elements **660**, which serve to release the implant **645** from the delivery system, and one or more adjustment elements **665** which serve to adjust the implant's deployed size and effect. Because the release elements **660** and adjustment elements **665** extend through the proximal end of the core catheter **615**, as seen in FIGS. **14-16**, these elements can be directly or indirectly instrumented or manipulated by the physician. A delivery interface **670** (FIGS. **12, 16**) is defined in this example by the interaction of

the deployment umbrella **642**, the release elements **660**, and the implant **645**. In the disclosed embodiment, the release elements **660** may be a suture, fiber, or wire in a continuous loop that passes through laser-drilled bores in the implant **645** and in the radial implant support arms **630**, and then passes through the length of the core catheter **615**. In such an embodiment, the implant **645** may be released from the delivery system at a desired time by severing the release element **660** at its proximal end, outside the patient, and then withdrawing the free end of the release element **660** through the core catheter **610**.

FIGS. **14-16** show the operation of the implant/delivery system array **600**, in which an umbrella-like expansion of the prosthetic implant **645** is achieved by sliding movement of the housing sheath **605**, the actuating catheter **610**, and the core catheter **615**. Referring first to FIG. **14**, the housing sheath **605** is extended to cover the forward ends of the actuating catheter **610** and core catheter **615** for intravascular insertion of the implant/delivery system array **600**. From this starting position, the housing sheath **605** is retracted in the direction indicated by the arrows **662**. In FIG. **15** the housing sheath **605** has been retracted to expose the forward end of the actuating catheter **610** and the collapsed deployment umbrella **642**. From this position the actuating catheter **610** is advanced in the direction indicated by the arrows **664**. This will cause the deployment umbrellas to expand in the directions indicated by the arrows **666**. FIG. **16** shows the expansion of the deployment umbrella **642** produced by distal motion of the actuating catheter **610** relative to the core catheter **615**. After the implant **645** has been positioned and adjusted to the proper size, the housing sheath **605** is advanced in the direction indicated by the arrows **668** to collapse and to cover the deployment umbrella **642** for withdrawal of the device from the patient.

FIGS. **17** and **18** are schematic views illustrating the radial implant support arms **630** and the radial support struts **636** of the implant/delivery system array **600**. In FIG. **17**, a radial support strut **636** is pivotably attached at its proximal end **638** at a first pivotable joint **670** to the actuation catheter **610**. The radial support strut **636** is attached at its distal end **640** to a second pivotable joint **672** at an intermediate point of a corresponding radial implant support arm **630**. The radial implant support arm **630** is attached at its distal end **632** by a third pivotable joint **674** to the core catheter **620**. FIG. **17** shows the assembly in a closed state. When the actuation catheter **610** is advanced distally over the core catheter **615**, as shown by the arrows **676**, the radial support strut **636** and the radial implant support arm **630** are extended by the motion at the first pivotable joint **670**, the second pivotable joint **672**, and the third pivotable joint **674**, as shown by the arrow **678**. This motion has the effect of expanding the deployment umbrella and folded implant (not shown in FIGS. **17** and **18**), allowing it to achieve its greatest radial dimension, prior to engagement and implantation as previously discussed with reference to FIGS. **12-16**.

FIGS. **19** and **20** show further details of the touchdown sensors **648** shown previously in FIG. **12**. The touchdown sensor **648** of FIGS. **19** and **20** includes a distal segment **680**, an intermediate segment **682**, and a proximal segment **684**. The distal segment **680** is spring-mounted, so that it is capable of slidable, telescoping displacement over the intermediate segment **682** to achieve a seamless junction with the proximal segment **684** upon maximal displacement. When the touchdown sensor **648** is in its normal condition, the spring extends the proximal segment such that the sensor assumes the orientation shown in FIG. **19**. When the implant **645** (FIG. **12**) is seated against the periphery of an anatomical opening, the

proximal segment **684** of the sensor **648** is compressed against the distal segment **680**, as shown in FIG. **20**. The distal segment **680** and the proximal segment **684** are both constructed of, are sheathed by, or otherwise covered with a radio-opaque material. However, the intermediate segment **682** is not constructed or coated with such a radio-opaque material. Therefore, when the distal segment **680** is at rest, it is fully extended from the proximal segment **684**, and the gap represented by the exposed intermediate segment **682** is visible on radiographic examination. However, when the distal segment **680** is brought to maximum closeness with the proximal segment **684**, no such radio-opaque gap is radiographically visible, and the touchdown sensor is said to be "activated". This embodiment allows radiographic monitoring of the position of the touchdown sensor **648** with respect to the degree of extension of the distal catheter segment **680**. In the embodiment according to the present invention as shown, one or more touchdown detectors **648** are employed to ascertain that the delivery system for the prosthetic device is located in the proper position to deploy the implant into the mitral annulus. As this anatomic structure cannot be directly identified on fluoroscopy or standard radiographic procedures, such precise location could be otherwise difficult. At the same time, precise localization and engagement of the mitral annulus is critical for proper implant function and safety.

Touchdown detectors within the embodiments according to the present invention can have a multiplicity of forms, including the telescoping, spring-loaded, radio-opaque elements joined by a non-radio-opaque element as in the aforementioned examples. In embodiments employing magnetic resonance imaging, touchdown detectors according to the present invention may utilize metallic segments interposed by nonmetallic segments in a similar telescoping, spring-loaded array. Other embodiments include a visually-evident system with telescoping, spring-loaded elements with color-coded or other visual features for procedures in which direct or endoscopic observation would be possible. Still other embodiments of touchdown detectors according to the present invention include touchdown detectors provided with microswitches at their tips, such that momentary contact of sufficient pressure completes an electrical circuit and signals the activation of the touchdown detector to the operator. Still other touchdown detectors according to the present invention are provided with fiberoptic pathways for Raman laser spectroscopy or other spectral analytical techniques which are capable of detecting unique tissue qualities of the tissue at the desired site for implantation. In addition, still other embodiments according to the present invention include touchdown detectors containing electrodes or other electronic sensors capable of detecting and signaling the operator when a desired electrophysiologic, impedance, or other measurable quality of the desired tissue is detected for proper implantation. Such electrophysiologic touchdown detectors may include electrical circuits that produce visual, auditory, or other signals to the operator that the detectors are activated and that the implant is in the proper position for attachment.

In yet other embodiments according to the present invention, other intracardiac or extracardiac imaging techniques including, but not limited to, intravascular ultrasound, nuclear magnetic resonance, virtual anatomic positioning systems, or other imaging techniques may be employed to confirm proper positioning of the implant, obviating the need for the touchdown sensors as previously described.

FIGS. **21-24** show an implant **700** according to one embodiment of the present invention. In this embodiment, the implant body **705** is bandlike and flexible. Through much of its length, the implant body **705** is provided with a series of

retention bars **710** which are oriented to facilitate placement, retention, and removal of the device. The implant body **705** is also provided with an adjustable section **715**, which is provided in this example with a series of adjustment stops **720**. The adjustment stops **720** may be slots, holes, detents, dimples, ridges, teeth, raised elements, or other mechanical features to allow measured adjustment of the implant **700** in use. In the embodiment shown in FIGS. **21-24**, the adjustment stops **720** are engaged by a geared connector **725**. FIG. **21** is an end view, showing the implant body **705** curved on itself, with the retention bars **710** to the exterior, and with the adjustable section **715** passing through its engagement with the geared connector **725** and curving internally within the implant body **705** to form a closed, round structure. FIG. **23** shows details of an exemplary geared connector **725**, in which a housing **730** is connected to the implant body **705**. The housing **730** contains and supports a mechanical worm **740** with an attached first geared head **750** which mates with a second geared head **755**. The second geared head **755** is attached to an adjustment stem **760** which is machined to receive a screwdriver-like adjustment element. The various embodiments according to the present invention may require a number of forms of adjustment elements. In the present example, the adjustment element is provided as a finely coiled wire with a distal tip machined to be received by a receiving slot in the adjustment stem **760** (not shown). The relationship between the distal tip of the adjustment element and the adjustment stem **760** is mechanically similar to a screwdriver bit and screwhead, such that torsion imparted to the adjustment means by the operator will result in the turning of the adjustment stem **760** and second geared head **755** allows motion of the first geared head **750** and worm **740**, which creates motion of the adjustable implant section **715** as the worm engages with the series of adjustment tops **725**. Excess length of the adjustable section **715** passes through a band slot **735** (FIG. **23**), thus allowing the band to move concentrically inside the closed implant body **705**. The adjustment element in this embodiment may be designed to remain in place after the deployment umbrella has been retracted and withdrawn. The connection between the adjustment element's distal tip and the adjustment stem **760** may be a simple friction connection, a mechanical key/slot formation, or may be magnetically or electronically maintained.

As further shown in FIG. **21**, the exemplary embodiment employs unidirectional retention bars **710** which are attached to the outer perimeter of the implant body **705**. The retention bars **710** are oriented in a consistent, tangential position with respect to the implant body **705** such that rotational motion of the implant body will either engage or release the retention bars **710** upon contact with the desired tissue at the time of deployment. This positioning of the retention bars **710** allows the operator to "screw in" the implant **700** by turning the implant **700** upon its axis, thus engaging the retention bars **710** into the adjacent tissue. As shown in FIG. **24**, the retention bars **710** may each be further provided with a terminal hook **775** at the end which would allow for smooth passage through tissue when engaging the retention bars **710** by rotating the implant **700**, without permitting the implant **700** to rotate in the opposite direction, because of the action of the terminal hooks **775** grasping the surrounding tissue (much like barbed fish hooks). The terminal hooks **775** thus ensure the seating of the implant **700** into the surrounding tissue.

FIGS. **25-27** illustrate another embodiment of an implant **800** as contemplated according to the present invention. The implant **800** includes a band **805** (FIG. **27**), but the retention bars of the previous example have been eliminated in favor of an outer fabric implant sheath **810**. The fabric sheath **810**

can be sutured or otherwise affixed to the anatomic tissue in a desired location. The circumference of the implant body **800** is adjusted through a geared connector **825** similar to the geared connector of the bandlike implant array shown in FIG. **23**. More specifically, adjustment stops **820** on the band are engaged by a mechanical worm **840** with an attached first geared head **850**. The first geared head **850** mates with a second geared head **855**. The second geared head **855** is attached to an adjustment stem **860** which is machined to receive a screwdriver-like adjustment element.

FIG. **28** illustrates an example of the method of use of an implant/delivery system array **600** for positioning an implant **645** in a patient with ischemic annular dilatation and mitral regurgitation. Peripheral arterial access is obtained via conventional cutdown, arterial puncture, or other standard access techniques. After access to the arterial system is attained, guidewire placement is performed and intravascular access to the heart **900** is obtained using fluoroscopic, ultrasound, three-dimension ultrasound, magnetic resonance, or other real-time imaging techniques. The guidewire, deployment device, and implant are passed through the aortic valve in a retrograde fashion into the left ventricle **905** and then into the left atrium **910**. At this point, the operator retracts the housing sheath **605**, thus unsheathing the collapsed deployment umbrella **642** and implant **645**. The deployment umbrella **642** is then distended by the distal motion of the actuation catheter, causing the radial support arms and struts to fully distend. At this point, the touchdown detectors **648** are not in contact with any solid structures, and are fully extended with their radiolucent gaps visible on the imaging system. Once the deployment umbrella is distended, the entire assembly is pulled back against the area of the mitral valve **915**. At least two touchdown detectors **648** are employed in a preferred embodiment according to the present invention. When all touchdown detectors show the disappearance of their intermediate, non-opaque, intermediate segments and are thus activated, then the deployment umbrella must be in contact with the solid tissue in the region of the mitral annulus/atrial tissue, and further implant deployment and adjustment may proceed. However, if any one touchdown sensor is not activated, and a radiolucent gap persists, then the device is not properly positioned, and must be repositioned before further deployment. Thus, the touchdown sensor system may assist in the deployment and adjustment of prosthetic devices by the delivery system according to the present invention. Once properly positioned, the operator rotates the actuation catheter in a prescribed clockwise or counterclockwise manner to engage the retention bars on the implant into the tissue in the region of the mitral annulus/atrial tissue. Should re-positioning be required, a reverse motion would disengage the retention bars from the annular/atrial tissue, and repositioning may be performed, again using the touchdown detectors for proper placement. Once firmly seated, the adjustment element(s) are operated to achieve the desired degree of annular reduction. Real-time trans esophageal echocardiography, intravascular echocardiography, intracardiac echocardiography, or other modalities for assessing mitral function may then be employed to assess the physiologic effect of the repair on mitral function, and additional adjustments may be performed. Once a desired result has been achieved, the release elements are activated to detach the implant from the deployment umbrella. The operator then retracts the actuation catheter and extends the housing sheath, collapsing the deployment umbrella and covering the components for a smooth and atraumatic withdrawal of the device from the heart and vascular system.

If desired, the adjustment elements may be left in position after the catheter components are withdrawn for further physiologic adjustment. In yet other embodiments according to the present invention, a catheter-based adjustment elements may subsequently be re-inserted through a percutaneous or other route. Such an adjustment element may be steerably operable by the operator, and may be provided with magnetic, electronic, electromagnetic, or laser-guided systems to allow docking of the adjustment element with the adjustable mechanism contained within the implant. In still other embodiments, the adjustment mechanism may be driven by implanted electromechanical motors or other systems, which may be remotely controlled by electronic flux or other remote transcutaneous or percutaneous methods.

In the case of pulmonic valve repair, initial catheter access is achieved through a peripheral or central vein. Access to the pulmonary valve is also achieved from below the valve once central venous access is achieved by traversing the right atrium, the tricuspid valve, the right ventricle, and subsequently reaching the pulmonic valve.

In yet other embodiments according to the present invention, catheter access to the left atrium can be achieved from cannulation of central or peripheral veins, thereby achieving access to the right atrium. Then a standard atrial trans-septal approach may be utilized to access the left atrium by creation of an iatrogenic atrial septal defect (ASD). In such a situation, the mitral valve may be accessed from above the valve, as opposed to the retrograde access described in Example 1. The implant and a reversed deployment umbrella may be utilized with implant placement in the atrial aspect of the mitral annulus, with the same repair technique described previously. The iatrogenic ASD may then be closed using standard device methods. Access to the aortic valve may also be achieved from above the aortic valve via arterial access in a similar retrograde fashion.

Other embodiments of the adjustable implant and methods according to the present invention include gastrointestinal disorders such as gastro-esophageal reflux disease (GERD), a condition in which the gastro-esophageal (GE) junction lacks adequate sphincter tone to prevent the reflux of stomach contents into the esophagus, causing classic heartburn or acid reflux. This not only results in discomfort, but may cause trauma to the lower esophagus over time that may lead to the development of pre-cancerous lesions (Barrett's esophagus) or adenocarcinoma of the esophagus at the GE junction. Surgical repair of the GE junction has historically been achieved with the Nissen Fundoplication, an operative procedure with generally good results. However, the Nissen procedure requires general anesthesia and a hospital stay. Utilizing the devices and methods according to the present invention, an adjustable implant would obviate the need for a hospital stay and be performed in a clinic or gastroenterologist's office. Referring now to FIGS. 29 and 30, an umbrella deployment device 600 with implant 645 is passed under guidance of an endoscope 1000, through the patient's mouth, esophagus 1005, and into the stomach 1010, where the deployment device 600 is opened with expansion of the implant 645 and touchdown detectors 648 with a color-coded or otherwise visible gap. The touchdown detectors are then engaged onto the stomach around the gastroesophageal junction 1015 under direct endoscopic control until all touchdown detectors 648 are visually activated. The implant is then attached to the stomach wall, 1020 the umbrella 642 is released and withdrawn, leaving behind the implant 645 and the adjustment elements. The implant is then adjusted until the desired effect is achieved, i.e., minimal acid reflux either by patient symptoms, pH monitoring of the esophagus, imag-

ing studies, or other diagnostic means. If the patient should suffer from gas bloat, a common complication of gastroesophageal junction repair in which the repair is too tight and the patient is unable to belch, the implant can be loosened until a more desirable effect is achieved.

In various embodiments anticipated by the present invention, the implant body may be straight, curved, circular, ovoid, polygonal, or some combination thereof. In various embodiments anticipated by the present invention the implant may be capable of providing a uniform or non-uniform adjustment of an orifice or lumen within the body. The implant body may further completely enclose the native recipient anatomic site, or it may be provided in an interrupted form that encloses only a portion of the native recipient anatomic site. In still other embodiments of the present invention, the implant body may be a solid structure, while in yet other embodiments the implant body may form a tubular or otherwise hollow structure. In one embodiment of the present invention, the body may further be a structure with an outer member, an inner member, and optional attachment members. In such an embodiment, the outer member of the implant body may serve as a covering for the implant, and is designed to facilitate and promote tissue ingrowth and biologic integration to the native recipient anatomic site. The outer member in such an embodiment may be fabricated of a biologically compatible material, such as Dacron, PTFE, malleable metals, other biologically compatible materials or a combination of such biologically compatible materials in a molded, woven, or non-woven configuration. The outer member in such an embodiment also serves to house the inner member. In this embodiment, the inner member provides an adjustment means that, when operated by an adjustment mechanism, is capable of altering the shape and/or size of the outer member in a defined manner.

In alternate embodiments according to the present invention, the adjustment means may be located external to or incorporated within the outer member. In yet additional alternate embodiments contemplated by the present invention, the implant body may consist of an adjustment means without a separate outer member covering said adjustment means.

In various embodiments according to the present invention, the adjustment means may include a mechanism which may be threaded or non-threaded, and which may be engaged by the action of a screw or worm screw, a friction mechanism, a friction-detent mechanism, a toothed mechanism, a ratchet mechanism, a rack and pinion mechanism, or such other devices to permit discreet adjustment and retention of desired size a desired position, once the proper size is determined.

In yet other embodiments according to the present invention, the adjustment means may comprise a snare or purse string-like mechanism in which a suture, a band, a wire or other fiber structure, braided or non-braided, monofilament or multifilament, is capable of affecting the anatomic and/or physiologic effects of the implant device on a native anatomic recipient site upon varying tension or motion imparted to said wire or fiber structure by a surgeon or other operator. Such an adjustment means may be provided as a circular or non-circular structure in various embodiments. Changes in tension or motion may change the size and/or shape of the implant.

In various embodiments according to the present invention, the adjustment means may be a metallic, plastic, synthetic, natural, biologic, or any other biologically-compatible material, or combination thereof. Such adjustment means may further be fabricated by extrusion or other molding techniques, machined, or woven. Furthermore, in various embodiments of the present invention, the adjustment means

may be smooth or may include slots, beads, ridges, or any other smooth or textured surface.

In various embodiments of the present invention, the implant body may be provided with one or more attachment members such as grommets or openings or other attachment members to facilitate attachment of the implant to the native recipient site. In alternate embodiments, the implant body may attach to or incorporate a mechanical tissue interface system that allows a sutureless mechanical means of securing the implant at the native recipient site. In still other alternate embodiments, sutures or other attachment means may be secured around or through the implant body to affix the implant body to the native recipient site. In yet other embodiments of the present invention, mechanical means of securing the implant body to the native recipient site may be augmented or replaced by use of fibrin or other biologically-compatible tissue glues or similar adhesives.

In additional various embodiments according to the present invention, the adjustable implant may be employed to adjustably enlarge or maintain the circumference or other dimensions of an orifice, ostium, lumen, or anastomosis in which a disease process tends to narrow or constrict such circumference or other dimensions.

In various embodiments according to the present invention, an adjustment mechanism may be provided to interact with the adjustment means to achieve the desired alteration in the size and/or position of the adjustment means. Such an adjustment mechanism may include one or more screws, worm-screw arrays rollers, gears, frictional stops, a friction-detent system, ratchets, rack and pinion arrays, micro-electromechanical systems, other mechanical or electromechanical devices or some combination thereof.

In some embodiments as contemplated by the present invention, an adjustment tool may be removably or permanently attached to the adjustment mechanism and disposed to impart motion to the adjustment mechanism and, in turn, to the adjustment means to increase or decrease the anatomic effect of the implant on the native recipient site.

In alternate embodiments according to the present invention, micromotor arrays with one or more micro-electromechanical motor systems with related electronic control circuitry may be provided as an adjustment means, and may be activated by remote control through signals convey by electromagnetic radiation or by direct circuitry through electronic conduit leads which may be either permanently or removably attached to said micromotor arrays.

In still other various embodiments according to the present invention, the adjustment mechanism may be provided with a locking mechanism disposed to maintain the position of the adjustment means in a selected position upon achievement of the optimally desired anatomic and/or physiologic effect upon the native recipient site and the bodily organ to which it belongs. In other embodiments, no special locking mechanism may be necessary due to the nature of the adjustment means employed.

In yet other alternate embodiments according to the present invention, the adjustment means and/or the outer member structure may be a pliable synthetic material capable of rigidification upon exposure to electromagnetic radiation of selected wavelength, such as ultraviolet light. In such embodiments, exposure to the desired electromagnetic radiation may be achieved by external delivery of such radiation to the implant by the surgeon, or by internal delivery of such radiation within an outer implant member using fiberoptic carriers placed within said outer member and connected to an appropriate external radiation source. Such fiberoptic carriers may be disposed for their removal in whole or in part from the

outer implant member after suitable radiation exposure and hardening of said adjustment means.

The present invention also provides methods of using an adjustable implant device to selectively alter the anatomic structure and/or physiologic effects of tissues forming a passageway for blood, other bodily fluids, nutrient fluids, semi-solids, or solids, or wastes within a mammalian body. Various embodiments for such uses of adjustable implants include, but are not limited to, open surgical placement of said adjustable implants at the native recipient site through an open surgical incision, percutaneous or intravascular placement of said implants under visual control employing fluoroscopic, ultrasound, magnetic resonance imaging, or other imaging technologies, placement of said implants through tissue structural walls, such as the coronary sinus or esophageal walls, or methods employing some combination of the above techniques. In various embodiments as contemplated by the present invention, adjustable implants may be placed and affixed in position in a native recipient anatomic site by trans-atrial, trans-ventricular, trans-arterial, trans-venous (i.e., via the pulmonary veins) or other routes during beating or non-beating cardiac surgical procedures or endoscopically or percutaneously in gastrointestinal surgery.

Furthermore, alternate methods for use of an adjustable implant device may provide for the periodic, post-implantation adjustment of the size of the anatomic structure receiving said implant device as needed to accommodate growth of the native recipient site in a juvenile patient or other changes in the physiologic needs of the recipient patient.

Adjustment of the adjustable implants and the methods for their use as disclosed herein contemplates the use by the surgeon or operator of diagnostic tools to provide an assessment of the nature of adjustment needed to achieve a desired effect. Such diagnostic tools include, but are not limited to, transesophageal echocardiography, echocardiography, diagnostic ultrasound, intravascular ultrasound, virtual anatomic positioning systems integrated with magnetic resonance, computerized tomographic, or other imaging technologies, endoscopy, mediastinoscopy, laparoscopy, thoracoscopy, radiography, fluoroscopy, magnetic resonance imaging, computerized tomographic imaging, intravascular flow sensors, thermal sensors or imaging, remote chemical or spectral analysis, or other imaging or quantitative or qualitative analytic systems.

In one aspect, the implant/delivery system of the present invention comprises a collapsible, compressible, or distensible prosthetic implant and a delivery interface for such a prosthetic implant that is capable of delivering the prosthetic implant to a desired anatomic recipient site in a collapsed, compressed, or non-distended state, and then allowing controlled expansion or distension and physical attachment of such a prosthetic implant by a user at the desired anatomic recipient site. Such a system permits the delivery system and prosthetic implant to be introduced percutaneously through a trocar, sheath, via Seldinger technique, needle, or endoscopically through a natural bodily orifice, body cavity, or region and maneuvered by the surgeon or operator to the desired anatomic recipient site, where the delivery system and prosthetic implant may be operably expanded for deployment. When desirable, the implant/delivery system according to the present invention is also capable of allowing the user to further adjust the size or shape of the prosthetic implant once it has been attached to the desired anatomic recipient site. The delivery system according to the present invention is then capable of detaching from its interface with the prosthetic implant and being removed from the anatomic site by the operator. The delivery system and prosthetic implant may be

provided in a shape and size determined by the anatomic needs of an intended native recipient anatomic site within a mammalian patient. Such a native recipient anatomic site may be a heart valve, the esophagus near the gastro-esophageal junction, the anus, or other anatomic sites within a mammalian body that are creating dysfunction that might be relieved by an implant capable of changing the size and shape of that site and maintaining a desired size and shape after surgery.

In various embodiments contemplated by the present invention, the delivery system may be a catheter, wire, filament, rod, tube, endoscope, or other mechanism capable of reaching the desired recipient anatomic site through an incision, puncture, trocar, or through an anatomic passageway such as a vessel, orifice, or organ lumen, or trans-abdominally or trans-thoracically. In various embodiments according to the present invention, the delivery system may be steerable by the operator. The delivery system may further have a delivery interface that would retain and convey a prosthetic implant to the desired recipient anatomic site. Such a delivery interface may be operably capable of distending, reshaping, or allowing the independent distension or expansion of such a prosthetic implant at the desired recipient anatomic site. Furthermore, such a delivery interface may provide an operable means to adjust the distended or expanded size, shape, or physiologic effect of the prosthetic implant once said implant has been attached in situ at the desired recipient anatomic site. In various embodiments according to the present invention, such adjustment may be carried out during the procedure in which the implant is placed, or at a subsequent time. Depending upon the specific anatomic needs of a specific application, the delivery interface and the associated prosthetic implant may be straight, curved, circular, helical, tubular, ovoid, polygonal, or some combination thereof. In still other embodiments of the present invention, the prosthetic implant may be a solid structure, while in yet other embodiments the prosthetic implant may form a tubular, composite, or otherwise hollow structure. In one embodiment of the present invention, the prosthetic implant may further be a structure with an outer member, an inner member, and optional attachment members. In such an embodiment, the outer member of the prosthetic implant may serve as a covering for the implant, and is designed to facilitate and promote tissue ingrowth and biologic integration to the native recipient anatomic site. The outer member in such an embodiment may be fabricated of a biologically compatible material, such as Dacron, PTFE, malleable metals, other biologically compatible materials or a combination of such biologically compatible materials in a molded, woven, or non-woven configuration. The outer member in such an embodiment also serves to house the inner member. In this embodiment, the inner member provides an adjustment means that, when operated by an adjustment mechanism, is capable of altering the shape and/or size of the outer member in a defined manner.

In some embodiments according to the present invention, at least some portions of the adjustable inner or outer member may be elastic to provide an element of variable, artificial muscle tone to a valve, sphincter, orifice, or lumen in settings where such variability would be functionally valuable, such as in the treatment of rectal incontinence or vaginal prolapse.

In various embodiments according to the present invention, the delivery interface would have an attachment means to retain and convey the prosthetic implant en route to the native anatomic recipient site and during any in situ adjustment of the prosthetic implant once it has been placed by the operator. Such an attachment means would be operably reversible to allow detachment of the prosthetic implant from the delivery

interface once desired placement and adjustment of the prosthetic implant has been accomplished.

In one embodiment of the present invention, illustrated in FIG. 31, an implantable device system **1000** for controlling at least the size or shape of an anatomical structure or lumen includes an implantable device **1002** and an adjustment tool **1006**. The anatomical structure or lumen is an anatomic site with dysfunction that can be relieved by the implantable device **1002** to change a size or shape of the anatomic site.

The implantable device **1002**, in one exemplary embodiment, has a diameter no larger than 3.5 mm. In another embodiment the implantable device **1002** is configured to have variable size relative to its placement at an annulus of a heart valve. The implantable device **1002** has an adjustable member **1004** configured to adjust the dimensions of the implantable device **1002**. In one embodiment, the torqueable adjustment tool **1006** provides adjustment of the dimensions of the implantable device **1002**. The adjustable member **1004**, in some embodiments, may be oriented to receive the adjustment tool from a direction generally perpendicular to the primary plane defined by the implant device **1002**. Such an orientation is advantageous for intravenous access of the tool and in situ adjustment of the implant device **1002**. The implantable device **1002** can have a configuration where there are different pulling rates at different sections of the implantable device **1002**. The implantable device **1002** may optionally include a flexible tube (**1032**, FIG. 38) and an outer fabric sheath (**810**, FIGS. 25 and 26), which are not shown in the subsequent figures for clarity. The outer fabric sheath can be sutured, stapled, clipped, coiled, or otherwise affixed to anatomic tissue in a desired location. Generally the desired location is considered to be the internal surface of the area to be controlled, such as (for example) an interior wall of an organ, artery, or other internal anatomic passage. Also, while the implantable device **1002** is generally shown in the subsequent figures to have a "D"-shaped configuration, it should be understood that other shapes can be used in accordance with embodiments of the present invention.

Still referring to FIG. 31, in certain embodiments, the adjustment tool **1006** is at least partially hollow, and in one specific embodiment at least 50% hollow. The adjustment tool **1006** may be an elongated tool, which has a proximal end and a distal end releasably attached to the adjustable member **1004** of implantable device **1002**. The adjustment tool **1006** may extend from its distal end coupled to the adjustable member **1004** to a control interface (e.g., handle) at the proximal end located preferably outside of the patient's body. The adjustment tool **1006**, when coupled to the adjustable member **1004** of implantable device **1002**, can provide a preferential shape change of the implantable device **1002** in planar and non-planar directions. The adjustment tool **1006** can adjust the implantable device **1002** in terms of narrowing or widening the dimensions of the implantable device **1002**.

FIG. 32A is a schematic of the implant device **1002** without showing an optional flexible outer tube and fabric sheath. The implantable device includes an adjustable member **1004** and adjustable tube portions **1013a** and **1013b**, which slide within hollow tube portions **1014a** and **1014b**, and retaining tube **1015**. FIG. 32B is a schematic of a disassembled portion of implantable device **1002** with retaining tube **1015** removed. As shown in FIG. 32B, in various embodiments, the implantable device **1002** includes a threaded rod **1008** threaded with right-hand helical grooves **1010** and left-hand helical grooves **1012**. Other embodiments may include a threaded rod **1008** with helical grooves in a single direction (e.g., all right-hand grooves or all left-hand grooves). Threaded rod **1008** may be a rigid material such as titanium, stainless steel, or a polymer.

Adjustable tube portions **1013a** and **1013b** enclose at least a portion of grooves **1010** and **1012** so that pins **1016a**, **1016b** or protuberances on the inside diameter of the adjustable tube portions **1013a**, **1013b** are engaged by the grooves **1010** and **1012**, respectively. In other embodiments, pins **1016a**, **1016b** may be replaced by threads along the inside diameter of the adjustable tube portions **1013a**, **1013b**. Helical grooves **1010** and **1012** may be single channels or multiple channels to engage single pins **1016a**, **1016b** or multiple pins. Hollow tube portions **1014a**, **1014b** are relatively rigid to maintain curvature of the adjustable tube portions **1013a**, **1013b** regardless of the adjustment position.

The implantable device **1002** can have a coating including, but not limited to, heparin, and antibiotic, collagen, and an agent that promotes tissue in growth, PGLA, a de-calcification agent and the like. The implantable device **1002** can be made of a variety of materials including, but not limited to, a shape memory alloy (SMA), a shape memory polymer (SMP), titanium, stainless steel, polymer, a suture-based material, a biological material and the like.

In another embodiment of the present invention, illustrated in FIGS. **33** through **37**, the adjustable member **1004** provides translated motion through rotation. FIGS. **33** through **35** illustrate a theory of operation of an embodiment of the present invention, while FIGS. **36** and **37** shown details of the adjustable member **1004**.

Referring to now FIG. **33**, adjustable member **1004** of implantable device **1102** is shown including a docking port **1021** to receive the distal tip of the adjustment tool **1006** (FIG. **31**). In this embodiment, implant device includes a set of inner tubing **1028a**, **1028b** and a set of outer tubing **1026a**, **1026b** that can move relative to each other. The ends of the inner tubing **1028a**, **1028b** that do not engage the outer tubing **1026a**, **1026b** are secured to a set of hollow tubing **1014a**, **1014b** so that the inner tubing **1028a**, **1028b** does not move relative to the hollow tubing **1014a**, **1014b**. Although hollow tube portions **1014a**, **1014b** may be separate pieces that are permanently abutted when assembled, in some embodiments, the hollow tube portions **1014a**, **1014b** may be formed from a single tubing piece. An inner cable **1030** passes through the various tubing. Thus, the rigidity of the hollow tubing can be used to maintain the adjustable implant **1102** shape in certain dimensions so that adjustment of the device can be restricted to a preferred dimension, for example, an anterior-posterior dimension.

As shown in more detail in FIGS. **36** and **37**, adjustable member **1004** may also include a pinion gear **1022** (which may be integral to a docking port **1021**) and a crown gear **1024**. FIG. **36** provides an isometric view of the adjustable member **1004**, and FIG. **37** provides a cut-away view of the adjustable member **1004**. As can be seen in the figures, the pinion gear **1022** engages the crown gear **1024**. In some embodiments, the pinion gear **1022** may be eliminated from adjustable member **1004**, and the distal tip of the adjustment tool **1006** may serve as the pinion gear when the tool is coupled to the docking port **1021**. When coupled to the docking port **1021**, the adjustment tool **1006** can rotate the pinion gear **1022**.

Referring back to FIG. **33**, the implantable device **1102** is shown generally at the middle of its adjustment range. Outer tubing **1026a**, **1026b** is affixed to the adjustable member **1004** and extends along a portion of the circumference of implantable device **1102**. Inner tubing **1028a**, **1028b** is affixed to hollow tubing **1014a**, **1014b**, respectively. Similar to the single threaded rod **1008** of FIG. **32B**, threaded rods **1018a**, **1018b** sit inside the hollow tubing **1014a**, **1014b** and are threadedly engaged therewith. Threaded rods **1018a**, **1018b**

may be a rigid material such as titanium, stainless steel, or a polymer. Hollow tube portions **1014a**, **1014b** enclose the threaded rods **1018a**, **1018b** such that rotation of the threaded rods **1018a**, **1018b** causes them to move axially within the hollow tube portions **1014a**, **1014b**. The threaded rod **1018a** may have right-handed threads, and the threaded rod **1018b** may have left handed threads. Other embodiments may include threaded rods **1018a**, **1018b** with threads in a single direction (e.g., all right-hand grooves or all left-hand threads).

The crown gear **1024**, and one end of each threaded rod **1018a**, **1018b** are all attached to an inner cable **1030**. Inner cable **1030** may be a cable or tube of any material with sufficient flexibility to conform to a shape of the implantable device **1102** while translating torque. For example, suitable material for inner cable **1030** may include titanium or stainless steel. As shown more clearly in FIGS. **36** and **37**, the rotation of crown gear **1024** imparts rotation to cable **1030** in the same direction.

Referring to FIG. **34**, when the handle of adjustment tool **1006** (not shown in this figure) is rotated clockwise in docking port **1021**, it causes clockwise rotation of the pinion gear **1022** (in FIG. **36**). Rotation of the pinion gear **1022** in turn rotates crown gear **1024**. The rotation of crown gear **1024** causes rotation of inner cable **1030**, which imparts rotational movement to each threaded rod **1018a**, **1018b**. The rotation applied to the threaded rods **1018a**, **1018b** causes them to advance into their respective hollow tubing **1014a**, **1014b** in the directions A_1 , A_2 shown. As shown in FIG. **34**, when threaded rods **1018a**, **1018b** advance toward the middle of the hollow tubing **1014a**, **1014b** the overall circumference of the implant device **1002** is reduced. Advancing the threaded rods **1018a**, **1018b** drives the inner cable **1030** into the hollow tubing **1014a**, **1014b**. Translation of inner cable **1030** into the hollow tubing **1014a**, **1014b** causes the hollow tubing **1014a**, **1014b** to move towards adjustable member **1004** in the direction B_1 shown. Inner tubing **1028a**, **1028b** slides into outer tubing **1026a**, **1026b** to accommodate movement of the inner cable **1030**.

Referring to FIG. **35**, the handle of adjustment tool **1006** (not shown in this figure) is rotated counter-clockwise in docking port **1021** to cause counter-clockwise rotation of the pinion gear **1022** (FIG. **36**). Rotation of the pinion gear **1022**, in turn rotates crown gear **1024**. The rotation of crown gear **1024** causes rotation of inner cable **1030**, which imparts rotational movement to each threaded rod **1018a**, **1018b**. The rotation applied to the threaded rods **1018a**, **1018b** causes them to begin to withdraw from their respective hollow tubing **1014a**, **1014b** in the directions A_2 , A_1 shown. As shown in FIG. **35**, as threaded rods **1018a**, **1018b** withdraw from the middle of the hollow tubing **1014a**, **1014b** the overall circumference of the implant device **1002** is increased. Withdrawal of the threaded rods **1018a**, **1018b** pushes the inner cable **1030** out of the hollow tubing **1014a**, **1014b**. Translation of inner cable **1030** out of the hollow tubing **1014a**, **1014b** causes the hollow tubing **1014a**, **1014b** to move away from adjustable member **1004** in the direction B_2 shown. Inner tubing **1028a**, **1028b** telescopes out of outer tubing **1026a**, **1026b** to accommodate movement of the inner cable **1030**.

The inner tubing **1028a**, **1028b**, the outer tubing **1026a**, **1026b**, and the hollow tubing **1014a**, **1014b** may be covered by a flexible tube **1032**, such as a silicone tube, shown in FIG. **38**. In one embodiment, outer flexible tube **1032** is provided with no seam in the axial direction of the tube to allow for better tissue ingrowth after the implant procedure. In other embodiments inner tubing **1028a**, **1028b** may be eliminated, as shown in FIG. **39**.

FIG. 39 provides an assembled cross-section view of an implantable device 1202 according to an embodiment of the invention. The implant device includes the adjustable member 1004, the outer tubing 1026a, 1026b, the hollow tubing 1014a, 1014b, the inner cable 1030, and the threaded rods 1018a, 1018b as discussed in relation to FIGS. 33-35. As shown in FIG. 39, hollow tubing 1014a, 1014b may extend further along the length of inner cable 1030 than shown in other embodiments of FIGS. 33-35 to better maintain a preferred shape of the implant. Hollow tubing 1014a, 1014b may be threaded to receive the threaded rods 1018a, 1018b; or hollow tubing may optionally include a threaded insert (spar 1019a, 1019b) affixed to the inner diameter of hollow tubing 1014a, 1014b. In operation, as previously described, an adjustment tool may impart motion to the adjustable member 1004. Gears in the adjustable member translate motion to the inner cable 1030 that, in turn translate motion to the attached threaded rods 1018a, 1018b. Depending on the direction of rotation, rotation of threaded rods 1018a, 1018b causes the threaded rods 1018a, 1018b to be drawn toward or away from the middle of the hollow tubing 1014a, 1014b, thus reducing or increasing the overall circumference of the implant device 1002. The flexible outer tube 1032 and a seal jacket 1100 (also shown in FIG. 40) encapsulate the device so that no moving parts are exposed. The flexible outer tube 1032 provide sufficient rigidity to maintain a generally planar dimension, while allowing the device to adjust shape generally in a preferred dimension, such as the anterior-posterior dimension. As shown in FIG. 39, the flexible outer tube 1032 may be further covered by an outer fabric sheath 1110 or thin sewing cuff. Elimination of the inner tubing (1028a, 1028b of FIG. 35) eliminates the need for telescoping parts and prevents the possibility of telescoping tubes being sutured or clipped together during attachment of the implant.

Referring to FIG. 40, the adjustable member 1004 can include a seal jacket 1100. FIG. 40 shows an embodiment of the seal jacket 1100. The seal jacket 1100 may include a cover 1102 for the docking port 1021 (FIG. 33) of the adjustable member 1004. The cover 1102 may be in the form of a slit septum, flaps, elastic material or the like. The seal jacket cover 1102 may be included as part of a seal jacket 1100 that covers the entire housing of the adjustable member 1004 or a separate piece. In one embodiment, the seal jacket 1100 may be secured to the flexible tube 1032. The seal jacket 1100 and flexible tube 1032 may be secured by an adhesive bond, a wrap, sutures, or the like. The cover 1102 provides access for an adjustment tool to couple to the docking port, while reducing the possibility of thrombus. In some embodiments, seal jacket cover 1102 and/or the seal jacket 1100 may be made of silicone, and covered by a polyester sewing layer or fabric sheath (e.g., 1110 of FIG. 39). In various embodiments, the seal jacket fits over the housing of the adjustable member 1004 that includes a crown gear coupled to a cable, can provide pinion access, and the like. In operation, the distal tip of an adjustment tool passes through the cover 1102 to engage the rotatable gear of adjustable member 1004.

FIG. 41 shows an embodiment of implantable device 1302 including a first adjustment band 1042a and a second adjustment band 1042b. The first and second adjustment bands 1042a, 1042b can be overlapped, and the amount of overlap is effected by how the implantable device 1302 is sized. The first and second bands 1042a, 1042b can be slidable relative to each other. An adjustable member 1304 is coupled to the first band 1042a and the second band 1042b, and pulls or pushes them toward or away from each other. The first band 1042a and the second band 1042b can have flexible portions 1046a, 1046b configured to create a flexible zone at the primary bend

regions 1047a, 1047b. The flexible portions 1046a, 1046b can have varying lengths and may also include one or more rigid portions 1044. These rigid portions 1044 can include welded braids or bands, or have a higher durometer material than the flexible portions 1046a, 1046b. The flexible portions 1046a, 1046b and rigid portions 1044 may be part of the same material as the first and second bands 1042a, 1042b, or one or more portions may be separate material that is joined to form continuous piece.

The first and second bands 1042a, 1042b can have different sizes or the same sizes. In one specific embodiment, the first and second bands 1042a, 1042b are about 0.5 to 3 mm in thickness and about 5 to 10 mm in width. The first and second bands 1042a, 1042b can be made of a variety of materials including, but not limited to, an SMA, an SMP, titanium, stainless steel, polymer, a suture-based material, a biological material and the like. In one embodiment, the first and second bands 1042a, 1042b include a plurality of band layers. At least a portion of the first and second bands 1042a, 1042b may have superelastic properties. Implant 1302 may include a flexible, extruded outer layer (not shown) or hollow tube, such as flexible tube 1032 of FIG. 38, to encase the structure formed by the first and second bands 1042a, 1042b flexible portions 1046a, 1046b, and rigid portions 1044. The parts of the first and second bands 1042a, 1042b, that extend past adjustable member 1304 can be contained within the hollow interior of the outer layer.

FIG. 42 provides a more detailed schematic view of the unassembled adjustment bands and adjustment member of FIG. 41. The first and second bands 1042a, 1042b may include a series of adjustment stops 1048. Adjustment stops may be in the form of holes, detents, dimples, ridges, teeth, raised elements, other mechanical features or the like. These holes 1048 on each of the bands 1042a, 1042b are coupled to an adjustable member 1304. The adjustable member 1304 may be generally cylindrical (such as a spool) with a series of teeth 1050 or protrusions radially positioned to engage the adjustment stops 1048. Adjustable member 1304 may also include a docking port 1320 to receive an adjustment tool to trigger rotational movement of the adjustable member.

FIG. 43 provides an assembled view of the adjustment band and adjustment member of FIG. 42. When mounted in a housing (not shown in FIG. 43), the adjustable member 1304 may be mounted on an axis to allow for rotational movement. The first and second bands 1042a, 1042b pass on either side of adjustable member 1304 so that the teeth 1050 engage the adjustment stops 1048 in each of the bands 1042a, 1042b. Rotating the adjustable member in turn tightens or loosens the bands.

FIG. 44 is a cut-away view of an embodiment of the gearbox for the adjustment band of FIG. 41. In this embodiment, the adjustable member 1304 rests on a spring 1052 inside a housing 1040 for the adjustable member. The housing 1040 includes access and guidance for the first and second bands (1042a, 1042b of FIG. 43) to couple with the teeth 1050 of the adjustable member 1304. The spring 1052 forces the adjustable member 1304 upward so that teeth 1056 on the top of the adjustable member 1304 engage with teeth 1058 on the inside upper surface of the housing 1040. Engagement of the adjustable member teeth 1056 with the housing teeth 1058 locks the adjustable member 1304 in place to prevent rotational movement. Downward force, applied for example by an adjustment tool, against the spring 1052 disengages the teeth 1056 and 1058 so that the adjustable member 1304 can be rotated to adjust the size or shape of implantable device 1302.

In another embodiment, FIG. 45 provides a schematic view of an implantable device 1402 of the present invention with a

plurality of sliding bands that can be opened and closed to effect a shape change. As with the previous embodiments of FIGS. 41-44, the first and second bands 1042a, 1042b pass on either side of adjustable member 1304 so that the teeth 1050 engage the adjustment stops 1048 in each of the bands 1042a, 1042b. Additional bands 1042c may be incorporated to increase stiffness at different areas of the implant device 1402 to provide preferential shape change. The additional bands 1042c may be secured to the first and second bands 1042a, 1042b using welds 1043, adhesive or other mechanical techniques known in the art.

As illustrated in FIG. 46, in one embodiment, an implantable device 1502 has an anterior portion 1060, a posterior portion 1062 and dual threads that provide preferential adjustment of one side or the other of implantable device 1502. The implantable device 1502 has two independently adjustable threaded portions 1064a, 1064b used to achieve different pulling rates and/or lateral dimensions. The adjustable threaded portions 1064a, 1064b can be connected to one or more adjustable member 1004 of the implantable device 1502 and positioned at either the posterior or anterior portions of the implantable device 1502. In one embodiment, the posterior portion 1062 may be a rigid member which includes threaded hex screws 1066a, 1066b, internal threads or similar structures. In one embodiment, the hex screws 1066a, 1066b are attached in a manner that allows rotation of the hex screws so that the threads may engage adjustable threaded portions 1064a, 1064b. Rigid posterior portion 1062 may include one or more of adjustable members 1004 that can receive a tool to impart rotational motion through an inner tube or cable to one or more of hex screws 1066a, 1066b, as described above. Anterior portion 1060 may be a flexible tube to accommodate shape change as the anterior and posterior portions 1060, 1062 move relative to each other.

In another embodiment, differently pitched threads or other mechanisms may be used to provide non-symmetrical shape change of the implant device. For example, referring to FIG. 46, wider threads on threaded portion 1064b, in relation to the threads of threaded portion 1064a, would allow an adjustable member 1004 to expand or contract the implant 1502 more rapidly on the side of threaded portion 1064b to provide preferential shape change for a selected region while using a single adjustable member.

FIG. 47 is a schematic view of an embodiment of an adjustable member 1604 for an implantable device. An adjustment tool may impart reciprocating motion to the adjustable member 1604 that includes a clover gear 1070 mounted in a housing 1072. The inner cable 1030 (FIG. 33) of the implantable device, for example, is affixed to the clover gear 1070 such that rotation of the clover gear transmits torque through the inner cable 1030 to a screw or other adjustable portion of the implantable device as previously disclosed. In this embodiment, the adjustment tool can provide reciprocating action to provide for adjustment. The adjustable member takes an axial force applied to the control portion at the proximal end of the adjustment tool and converts it to a rotational force applied to the inner cable 1030 of the implantable device. Reciprocating axial force may be provided from an adjustment tool by using spring-mounted buttons pressed by the user. Pressing a first button may transmit a downward axial motion to a first ribbon 1074 which engages the clover gear 1070 to cause clockwise rotation of the clover gear 1070. A spring or other return force pushes the first ribbon back to its original position after each click or press of the button. Similarly, pressing a second button may transmit a downward axial motion to a second ribbon 1076 that engages the clover gear 1070 to cause counter-clockwise rotation of the clover gear 1070.

In another embodiment, the adjustment tool provides coarse adjustment and fine adjustment. This varied adjustment can be achieved with the adjustment tool having screws with different threads.

FIG. 48 provides a schematic view of an embodiment of the implantable device system 1000 including an adjustment tool 1706 with high column strength and stiffness. The adjustment tool 1706 has a shaft 1794 and a handle 1096 with sufficient column strength to ensure a downward axial force on the handle 1096 provides proper engagement with the adjustable member 1004 of the implantable device 1002. The handle 1096 may be a grip-like handle, as shown, or a smaller pen-type handle. The adjustment tool 1706 can include mechanical locking at the distal region 1782 to lock with the adjustable member 1004. The mechanical locking is configured to provide engagement and disengagement tactile feel to the physician.

FIG. 49 is a schematic view of another embodiment of the implantable device system 1000 including an adjustment tool 1806 with reduced column stiffness. The adjustment tool 1806 has a handle 1096 a shaft 1080 with reduced column stiffness for greater flexibility and easier articulation of the adjustment tool 1806. The handle 1096 may be a grip-like handle, as shown, or a smaller pen-type handle. The easier articulation offered by the this embodiment may facilitate user positioning of the device in vivo and clearing adjacent biological structures, particularly when it is docked to the adjustable member 1004 of the implant 1002. Flexibility may be varied along the length of the adjustment tool shaft 1080. Flexibility may be increased at the distal region 1082 of the adjustment tool shaft 1006, particularly in the region immediately proximal to the gear/fitting at the distal tip of the adjustment tool 1006. This gear/fitting is constrained orthogonally to the adjustable member 1004, and it is important that the adjustment tool 1006 be easy to insert/connect and remain clear of biological structures.

FIG. 50 provides a view of an embodiment of the proximal end of the adjustment tool 1006. Referring to FIG. 50, adjustment tool 1006 includes a flexible cable 1094 or similar structure that is affixed to and rotates with a handle 1996. In other embodiments, the adjustment tool 1006 can have cables, a band, tubes, rods, and the like to impart rotational and/or axial motion from the proximal end to the distal tip of the tool 1006. The flexible cable 1094 may be enclosed by a flexible, low-friction cable jacket 1098 that allows the cable 1094 to rotate freely within the jacket 1098. In some embodiments, adjustment tool 1006 may also include a spring release mechanism to allow disengagement of the distal tip of the tool from the docking port 1021 (FIG. 33) with minimal force being applied to the sutures (or other mechanisms) securing the implant device to the tissue of an anatomic orifice or lumen. As shown in FIG. 50, in some embodiments, an e-clip 1099 or similar device may be used near the handle 1996 of the adjustment tool 1006 to secure the release mechanism in the docking station until adjustments are complete.

In one embodiment illustrated in FIG. 51, the adjustment tool 1006 may be inserted inside a rigid sheath 1092 that reaches the implantable device 1002. Thus, FIG. 51 is a schematic view of an embodiment of the implantable device system 1000 of the present invention with an articulated shape. The rigidity of the sheath 1092 provides the necessary column strength to support the flexible adjustment tool 1006. An added benefit to this embodiment is that the sheath may be left in place, docked to the implantable device 1002. The flexible adjustment tool 1006 may be removed and then reinserted at some future time to engage with the adjustable member 1004 of implantable device 1002.

The adjustment tool **1006** can have a handle **1096** that can be adjustable. The handle **1096** can have a length of at least 8 inches, and in one embodiment at least 10 inches. Other embodiments may have a shorter or longer handle length. The handle **1096** may be thick to provide a hand-grip, or, in other embodiments, smaller to provide a pen-like grip. The handle can have a device to quantify a size change of the implantable device **1002**. For example, a half-turn of the adjustment tool handle can be correlated to a distance of travel of the threaded rods **1018a**, **1018b** (FIG. 33) of an implant **1002**, thus allowing for measured adjustment of the implant. The handle may include a click-counter or other known device to measure rotational movement. In one embodiment, the adjustment tool **1006** may be included in a percutaneous delivery catheter.

A sensor, such as the touchdown sensor described in relation to FIGS. 12-18 above, can be coupled to the implantable device **1002**. A variety of different sensors can be utilized, including but not limited to, sensors that measure pressure, temperature and flow across the implantable device **1002**. Pacing leads are coupled to the sensor and the implantable device **1002**, and in this embodiment, the sensor is responsive to flow through the implantable device **1002**.

In another embodiment the implantable device system may include a micro-electromechanical motor system **1001** in conjunction with or instead of a separate adjustment tool to commence rotational movement in an adjustable member, see FIG. 31. Power and control of the micro-electromechanical motor system can be provided by electromagnetic radiation or through a direct wire connection and previously described herein.

Finally, it will be understood that the preferred embodiment has been disclosed by way of example, and that other modifications may occur to those skilled in the art without departing from the scope and spirit of the appended claims.

The invention claimed is:

1. An implantable device system for controlling at least one of the shape and size of an anatomical structure or lumen, comprising:

an implantable device having dimensions and adapted for attachment to an anatomical structure or lumen, said implantable device comprising an adjustable member and a plurality of telescopically arranged hollow tubes, said adjustable member configured to receive an adjustment tool and configured to both increase and decrease the dimensions of the implantable device by expanding between a fully contracted configuration and a fully expanded configuration, wherein said implantable device comprises at least one of said hollow tubes having at least one protuberance and at least one threaded rod threadedly engaged with said at least one protuberance such that rotation of the threaded rod causes the threaded rod to move axially within the hollow tube; and

a torqueable adjustment tool configured to provide adjustment of the dimensions of the implantable device, wherein adjustment of said adjustable member adjusts the size of the implantable device generally in a preferred dimension by varying the extent of the telescopic arrangement of the tubes between the fully expanded configuration and the fully contracted configuration, wherein said hollow tubes remain nested when expanding between the fully contracted and fully expanded configurations.

2. The system of claim 1, wherein the at least one protuberance comprises at least one thread.

3. The system of claim 2, wherein said implantable device comprises an inner cable to translate rotational motion to said threaded rod.

4. The system of claim 1, wherein said implantable device comprises a flexible tube covering an outer layer of said implant device.

5. The system of claim 1, wherein adjustment of said adjustable member adjusts the size of the implant device generally in an anterior-posterior dimension.

6. The system of claim 1, further comprising a sensor coupled to the implantable device.

7. The system of claim 6, wherein the sensor measures at least one of pressure, temperature, and flow across the implantable device.

8. The system of claim 1, wherein said adjustment tool comprises a handle, said handle including a member to quantify a size change of the implantable device.

9. The system of claim 1, wherein said adjustment tool is configured to impart reciprocating action to the adjustable member.

10. The system of claim 9, wherein said adjustable member comprises a clover gear to transmit radial torque.

11. The system of claim 10, wherein said adjustable member converts axial force applied from said adjustment tool to a rotation force applied to the implantable device.

12. The system of claim 1, wherein said adjustment tool is configured to provide both course adjustment and fine adjustment of said implantable device.

13. An implantable device system for controlling at least one of the shape and size of an anatomical structure or lumen, comprising:

an implantable device having dimensions and adapted for attachment to an anatomical structure or lumen, said implantable device comprising at least one adjustable member configured to receive an adjustment tool and configured to both increase and decrease the dimensions of the implantable device, wherein the implantable device includes dual threads formed by grooves that provide preferential adjustment of one side of the implantable device, wherein said implantable device comprises at least one hollow tube and at least one threaded rod having said grooves threadedly engaged with the hollow tube such that rotation of the threaded rod causes the threaded rod to move axially within the hollow tube; and

a torqueable adjustment tool configured to provide adjustment of the dimensions of the implantable device.

14. The system of claim 13, wherein said implantable device comprises at least one inner cable to translate rotational motion to said threaded rod.

15. The system of claim 13, wherein the implantable device includes a plurality of telescopically arranged hollow tubes, a dimension of the implantable device being altered by varying the extent of the telescopic arrangement of the tubes between expanded and contracted configurations.

16. The system of claim 13, wherein the implantable device includes a structure engaging the dual threads.

17. An implantable device adapted for attachment to an anatomical structure or lumen for controlling the size and/or shape of the anatomical structure or lumen, said device comprising:

an anterior region comprising one or more hollow rigid tubes having at least one protuberance threadedly engaged with one or more threaded rods having grooves forming threads;

a posterior region comprising one or more hollow rigid tubes and an adjustable member configured to translate rotational motion to at least one inner cable;

said inner cable operatively connected to said adjustable member and said threaded rod so as to translate rotational motion from said adjustable member to said threaded rod, wherein rotation of said threaded rod can both increase and decrease at least one dimensional relationship between the anterior region and the posterior region.

18. The implantable device of claim 17, further comprising at least one flexible tube that covers at least a portion of the anterior region and the posterior region.

19. The implantable device of claim 17, further comprising a micro-electromechanical motor system to commence rotational movement in said adjustable member.

20. The implantable device of claim 17, wherein one or more of the hollow rigid tubes of the anterior region or posterior region are telescopically arranged, a dimension of the implantable device being altered by varying the extent of the telescopic arrangement of the tubes between expanded and contracted configurations.

21. The implantable device of claim 17, wherein the at least one protuberance comprises a thread.

22. An implantable device system for controlling at least one of the shape and size of an anatomical structure or lumen, comprising:

an implantable device adapted for attachment to an anatomical structure or lumen, said implantable device comprising at least one hollow tube having at least one protuberance and at least one threaded rod having grooves forming threads threadedly engaged with the at least one protuberance such that rotation of the threaded rod causes the threaded rod to move axially within the hollow tube, said implantable device including an adjustable member configured to receive an adjustment tool; and

an adjustment tool configured to engage the adjustable member for adjusting at least one of the shape and size of the implantable device by varying the extent of the engagement of the at least one threaded rod and the at least one hollow tube.

23. The system of claim 22, wherein said implantable device includes an inner cable to translate rotational motion to said threaded rod.

24. The system of claim 22, wherein the implantable device includes a plurality of telescopically arranged hollow tubes, a dimension of the implantable device being altered by varying the extent of the telescopic arrangement of the tubes between expanded and contracted configurations.

25. An implantable device system for controlling at least one of the shape and size of an anatomical structure or lumen, comprising:

an implantable device adapted for attachment to an anatomical structure or lumen, said implantable device comprising a hollow tube having a flexible inner cable having a longitudinal axis and first and second ends, a rotatable adjustable member attached to said first end of said inner cable, and a rod rotatably received within said hollow tube and attached to said second end of said inner cable, said adjustable member configured to receive an adjustment tool; and

an adjustment tool configured to provide adjustment of at least one of the shape and size of the implantable device by rotation of the inner cable about its longitudinal axis by said adjustable member and rotation of said rod within said hollow tube.

26. The system of claim 25, wherein said adjustable member causes rotational motion of said inner cable in a clockwise and counter clockwise direction.

27. The system of claim 25, wherein the implantable device includes a plurality of telescopically arranged hollow tubes, a dimension of the implantable device being altered by varying the extent of the telescopic arrangement of the tubes between expanded and contracted configurations.

28. The system of claim 27, wherein said implantable device comprises at least one of said hollow tubes and at least one threaded rod having grooves forming threads threadedly engaged therewith such that rotation of the threaded rod causes the threaded rod to move axially within the hollow tube.

29. An implantable device system for controlling at least one of the shape and size of an anatomical structure or lumen, comprising:

an implantable device adapted for attachment to an anatomical structure or lumen, said implantable device comprising a hollow tube having a flexible inner cable having first and second ends and a longitudinal axis extending therethrough conforming to the shape of the implantable device, a rotatable adjustable member attached to said first end of said inner cable, and a rod rotatably received within said hollow tube and attached to said second end of said inner cable, said adjustable member configured to receive an adjustment tool; and

an adjustment tool configured to provide adjustment of at least one of the shape and size of the implantable device by rotation of the inner cable about its longitudinal axis by said adjustable member and rotation of said rod within said hollow tube.

* * * * *

专利名称(译)	用于控制解剖结构或内腔的尺寸的可植入装置		
公开(公告)号	US8758372	公开(公告)日	2014-06-24
申请号	US11/802264	申请日	2007-05-21
[标]申请(专利权)人(译)	MITRALSOLUTIONS		
申请(专利权)人(译)	mitralsolutions , Inc.		
当前申请(专利权)人(译)	ST.犹达医疗用品, 心脏病DIVISION, INC.		
[标]发明人	CARTLEDGE RICHARD G LEE LEONARD Y FANN JAMES I FRIEDMANN JOSEF L GREENE JAMES L		
发明人	CARTLEDGE, RICHARD G. LEE, LEONARD Y. FANN, JAMES I. FRIEDMANN, JOSEF L. GREENE, JAMES L.		
IPC分类号	A61B17/08 A61B5/00 A61B5/06 A61B6/12 A61B17/00 A61B17/04 A61B17/064 A61B17/068 A61B19/00 A61F2/00 A61F2/02 A61F2/04 A61F2/24 A61F2/30 A61F2/82		
CPC分类号	A61F2/2442 A61B5/061 A61B5/6885 A61B6/12 A61B17/00234 A61B17/0644 A61B17/068 A61B2017/00243 A61B2017/00455 A61B2017/00783 A61B2017/0496 A61B2017/0641 A61B2019/462 A61F2/0031 A61F2/2445 A61F2/2448 A61F2/2466 A61F2002/30537 A61F2250/0004 A61F2250/0029 A61B2090/062		
优先权	60/801861 2006-05-19 US 60/406841 2002-08-29 US 60/462435 2003-04-12 US 60/447383 2003-02-14 US 60/444005 2003-01-31 US		
其他公开文献	US20080027483A1		
外部链接	Espacenet USPTO		

摘要(译)

用于控制内部解剖学通道的尺寸的可植入装置系统校正由结构管腔导致的生理功能障碍, 所述结构管腔太大或太小。公开了可植入装置, 其采用各种机构来调节和保持它们所连接的孔的尺寸。系统允许使用微创手术植入植入物, 并允许在原位恢复正常解剖流体流后对植入物的尺寸进行最终调整。

