



US 20100268038A1

(19) **United States**

(12) **Patent Application Publication**
Smith

(10) **Pub. No.: US 2010/0268038 A1**

(43) **Pub. Date: Oct. 21, 2010**

(54) **REMOVABLE ENERGY SOURCE FOR
SENSOR GUIDEWIRE**

Publication Classification

(76) Inventor: **Leif Smith, Uppsala (SE)**

(51) **Int. Cl.**
A61B 5/00 (2006.01)

Correspondence Address:
FOLEY AND LARDNER LLP
SUITE 500
3000 K STREET NW
WASHINGTON, DC 20007 (US)

(52) **U.S. Cl.** **600/300**

(21) Appl. No.: **12/742,025**

(57) **ABSTRACT**

(22) PCT Filed: **Aug. 22, 2008**

A transmitter unit with an attachable energy source is provided for a sensor guidewire. The transmitter unit is adapted to be connected to a proximal end of a sensor guidewire provided, at its distal end, with a sensor to measure a physiological parameter inside a patient. In some embodiments, the transmitter unit is adapted to wirelessly communicate by a communication signal with a communication unit, arranged in connection with an external device, in order to transfer measured physiological data to the external device. The attachable energy source can be a battery pack or battery holder provided with connecting electrical connecting surfaces. Preferably, the connection is protected from penetrating fluids by a protective seal.

(86) PCT No.: **PCT/IB2008/002188**

§ 371 (c)(1),
(2), (4) Date: **May 7, 2010**

Related U.S. Application Data

(63) Continuation-in-part of application No. 11/937,123, filed on Nov. 8, 2007.

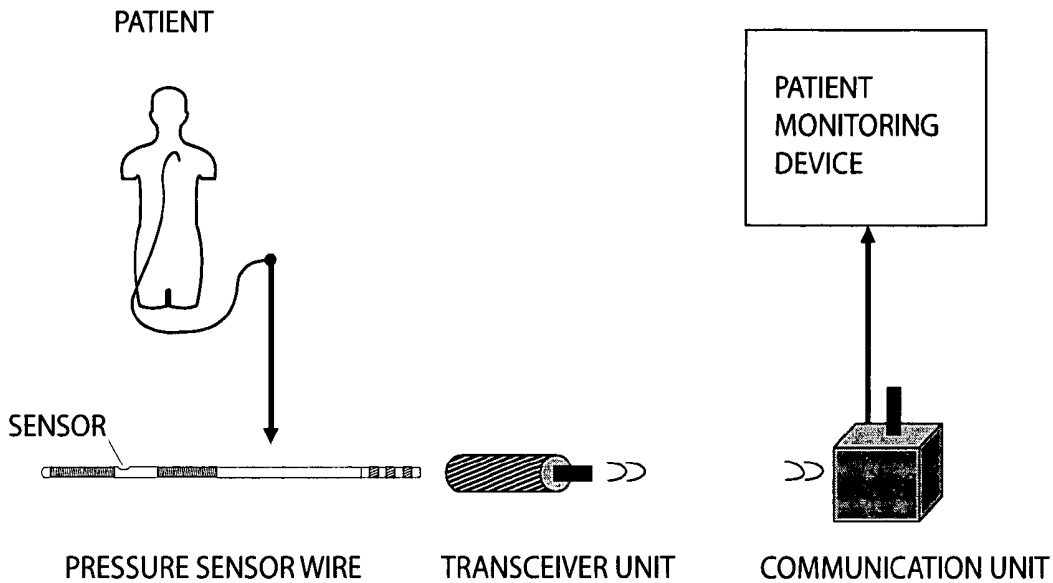

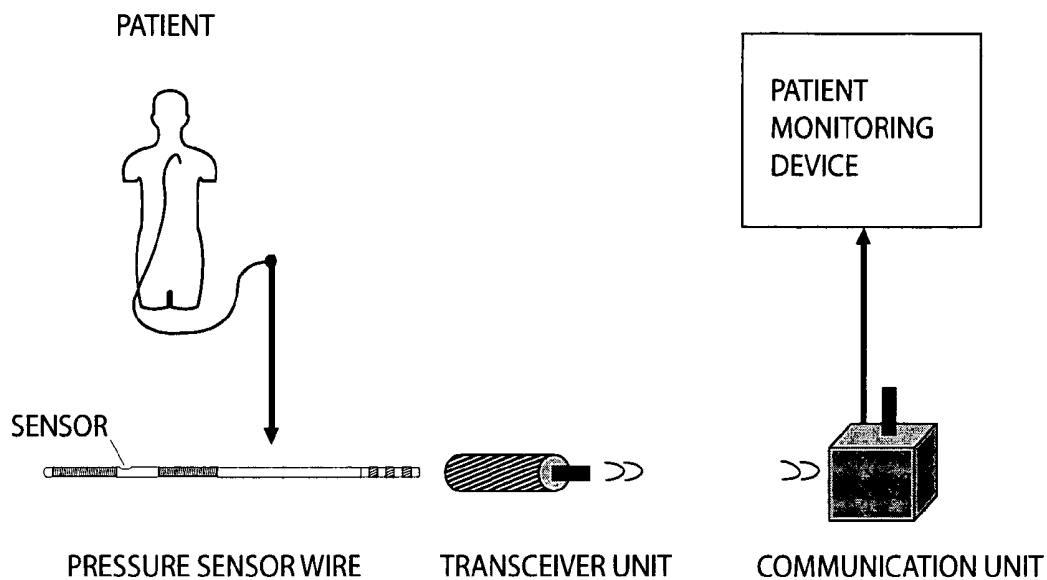

Fig. 1

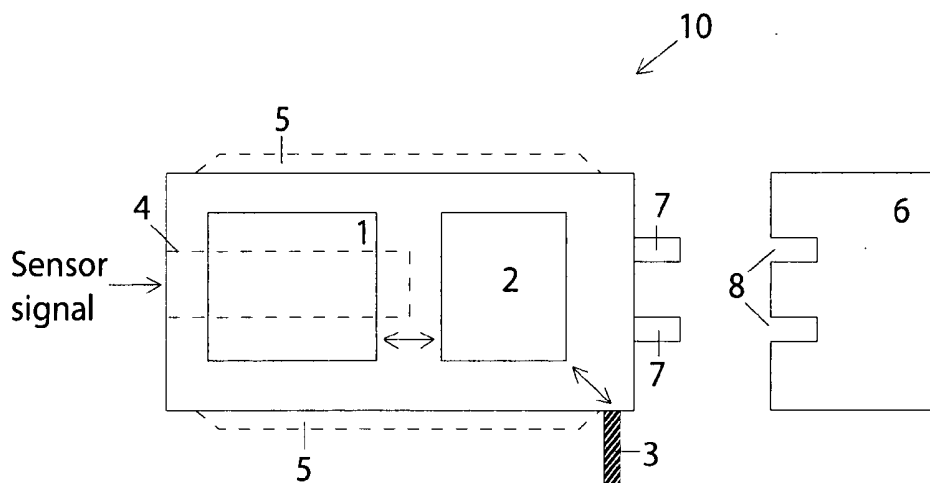

Fig. 2

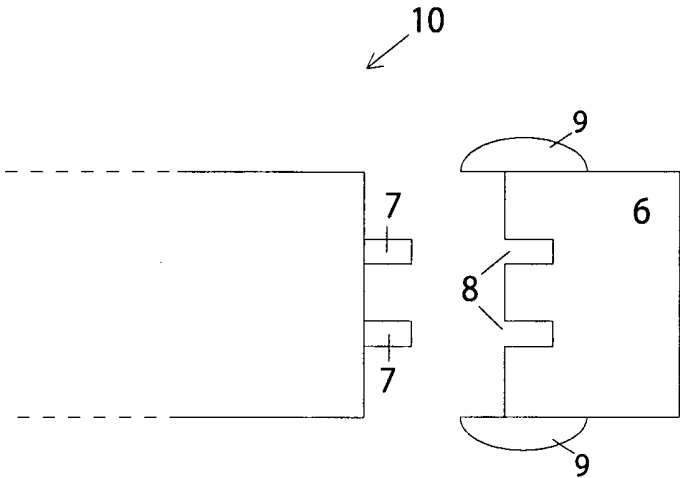

Fig. 3a

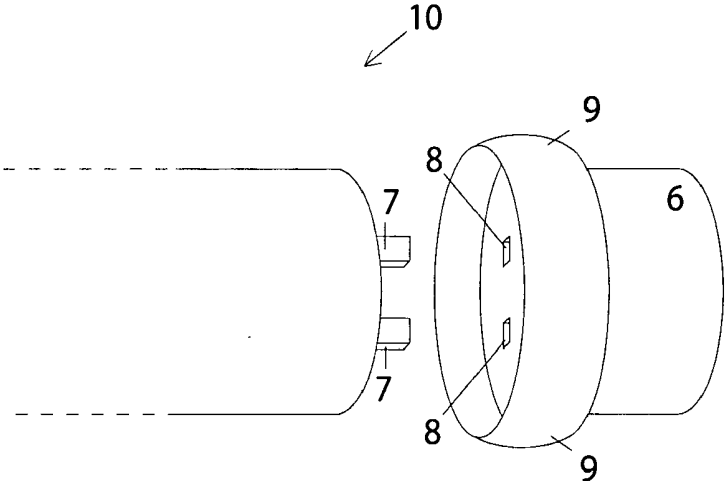

Fig. 3b

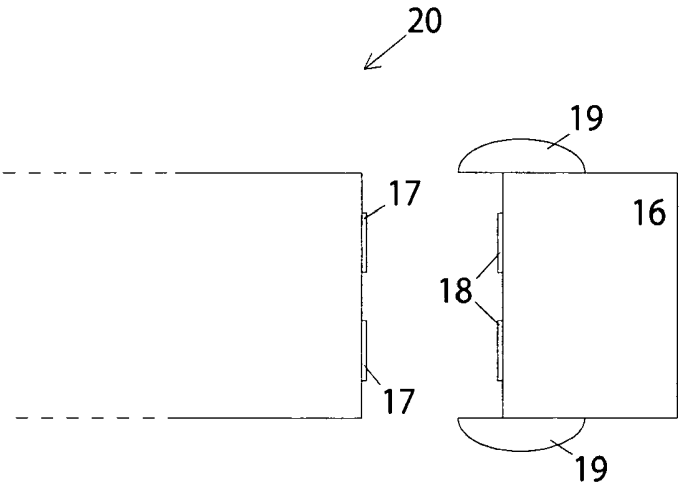

Fig. 4

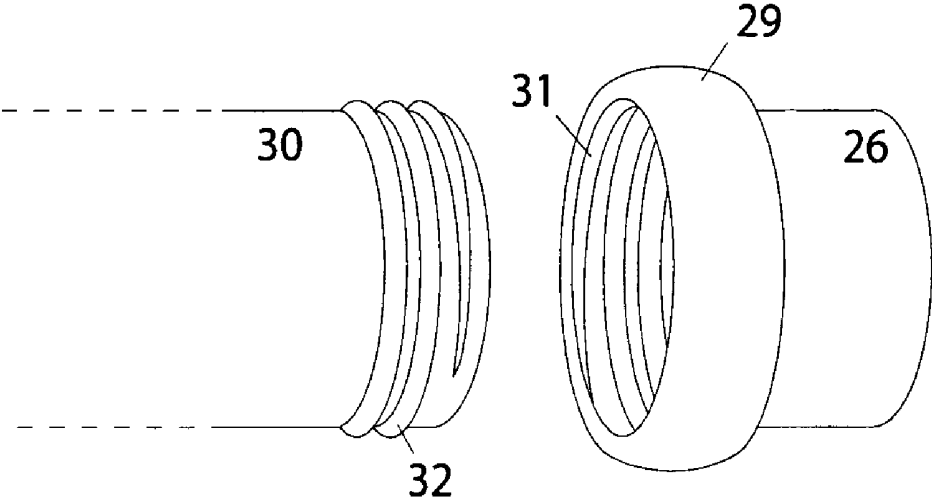

Fig. 5

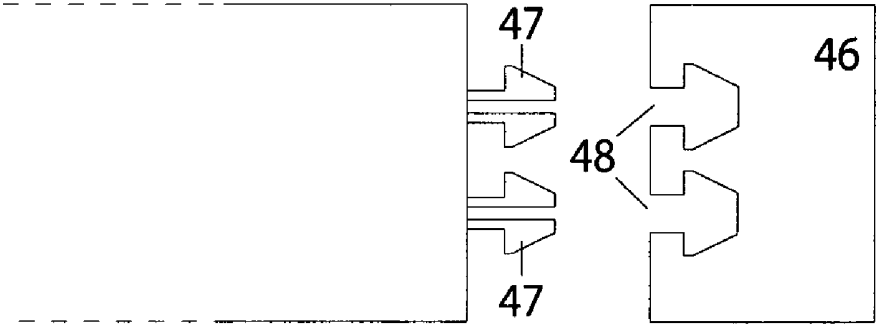

Fig. 6

REMOVABLE ENERGY SOURCE FOR SENSOR GUIDEWIRE

FIELD OF THE INVENTION

[0001] The present invention relates generally to a separate and/or removable energy source for sensor guidewires and in particular to an attachable and/or detachable battery pack or holder located on or at the transceiver unit in such an assembly.

BACKGROUND OF THE INVENTION

[0002] In many medical procedures, various physiological data within the body of a patient need to be monitored and analyzed. Typically, these data are physical in nature—such as pressure, temperature, and flow rate—and need to be monitored in a safe, reliable and accurate way. In the prior art, it is known to mount a sensor on a guidewire or catheter and to position the sensor via the guidewire in a blood vessel in a living body to detect such a physical parameter. The sensor includes elements that are directly or indirectly sensitive to the parameter. Numerous patents describing different types of sensors for measuring physiological parameters are assigned to the assignee of the present patent specification. For example, temperature can be measured by observing the resistance of a conductor having temperature sensitive resistance as described in U.S. Pat. No. 6,615,067. Another exemplifying sensor may be found in U.S. Pat. No. 6,167,763, in which blood flow exerts pressure on the sensor which delivers a signal representative of the exerted pressure.

[0003] The raw signal generated by the sensor located within the body is transmitted to an external device, in which the signal is re-translated into physiological data, which is processed and the results are continuously displayed on e.g. a monitor and/or saved. In order to power the sensor and communicate signals representing the measured physiological variable to an external device, one or more cables or leads for transmitting the signals are connected to the sensor, and are routed along the guidewire to be passed out from the vessel to the external device, conventionally via physical cables. In addition, the guidewire is typically provided with a central metal wire (core wire) serving as a support for the sensor and (optionally) also as an electrical connection to the sensor, and a surrounding tubing. Hence, a sensor guidewire typically comprises a core wire, leads and protective tubing, as well as a distal coil or tube and a jacket housing encasing the sensor.

[0004] In order to eliminate the risks of having an electrically conductive device such as a pressure transducer connected both to a patient and to an electronic monitoring instrument, a wireless arrangement can be used, e.g. as described in US Patent Application Publication No. 2006/0009817, assigned to the present assignee. In the aforementioned patent application, the pressure sensor wire is adapted to be connected, at its proximal end, to a transceiver unit that is adapted to wirelessly communicate via a communication signal with a communication unit arranged in connection with an external device, in order to transfer measured pressure data to the external device. In addition to the advantage of electrical insulation, a wireless arrangement decreases the amount of cables and other electrical equipment present in the operating room, and also facilitates the use of a standardized communication unit capable of being connected to a wide range of external devices. This obviates the necessity to use a specific external device, possibly different from that which is already

present in the operating room. However, in contrast to a conventional sensor guidewire assembly, the pressure sensor in a wireless arrangement is not in electrical connection with the external device. Therefore, an additional energy source may be required, such as a battery or capacitor, to power the transceiver unit and the pressure sensor. Also in a wired sensor guidewire assembly, a battery can be used as an alternative or auxiliary power supply.

[0005] An example of a medical device for measurement of internal temperature or pressure is disclosed in the German patent publication DE10 2005 003 171. In this arrangement, an energy source, which can be in the form of batteries, accumulators, or capacitors, can be plugged into a handle provided at the proximal end of a catheter. However, this publication does not mention that the energy source is contained in any kind of holder or connector.

[0006] Using a transceiver with an internal battery is not well-suited for use in a disposable single-use medical device intended for an extended procedure in a sterile environment, which is the normal situation for sensor guidewires. Therefore, an object of the present invention is to provide an energy source better adapted to the abovementioned conditions, for use with sensor guidewires and other medical devices wherein a sensor is inserted into a body cavity for measurement of a physiological parameter.

SUMMARY OF THE INVENTION

[0007] The above-mentioned object is achieved by the present invention according to the preamble of claim 1 and provided with the features according to the characterizing portion of the independent claim. Preferred embodiments are set forth in the dependent claims.

[0008] The present invention provides an attachable and separately manufactured and packaged energy source for a sensor guidewire assembly. Furthermore, the energy source is adapted to a sterile manufacturing and handling process, and is easily disposable in an environmentally acceptable manner. In addition, in some embodiments, the energy source can be adapted to be detached after completing a procedure, optionally recharged, re-sterilized and used in one or more subsequent sensor guidewire procedures. The energy source can be used in a wired or wireless setup in a sensor guidewire procedure.

[0009] In some embodiments, the energy source comprises one or several batteries. The batteries can be enclosed in a sealed holder. The battery pack is connected to a transmitter or transceiver unit whereupon, in some embodiments, the unit is powered up, calibrated and can optionally indicate by a light or sound signal that the assembly is ready for use.

[0010] In some embodiments, improper reuse of a sensor guidewire assembly (for example, reuse of an assembly designed for a single use) is prevented or discouraged by providing an energy source holder which cannot be disconnected from the guide wire once the energy source holder has been attached. With such a one-way attachment of an energy source, the sensor guidewire cannot be sterilized separately from the energy source, and re-sterilization of the (single-use) sensor guidewire assembly is therefore discouraged. In other embodiments, improper re-sterilization and reuse is prevented by specially designed software, which only allows the sensor to be powered up one time, i.e. restart of the sensor is inhibited.

BRIEF DESCRIPTION OF THE DRAWINGS

[0011] FIG. 1 illustrates one application of the present invention in a sensor guidewire assembly.

[0012] FIG. 2 shows a block diagram schematically illustrating a transmitter unit according to a preferred embodiment of the present invention.

[0013] FIGS. 3a and 3b illustrate the present invention according to a further embodiment, in cross-sectional view and perspective view, respectively.

[0014] FIG. 4 illustrates the present invention according to another embodiment.

[0015] FIG. 5 illustrates the present invention according to yet another embodiment.

[0016] FIG. 6 illustrates the present invention in a further embodiment.

DETAILED DESCRIPTION OF PREFERRED EMBODIMENTS

[0017] For ease of understanding, embodiments of the present invention are described in conjunction with a sensor guide wire. However, it is also within the scope of the invention to use an attachable energy source according to the present invention to power a transmitter unit connected to a sensor mounted on a catheter. Moreover, the transmitter unit is in many cases also a receiver unit. In those cases, the unit is, in fact, a transceiver unit, wherein the communication with the external device is a two-way communication. Thus, in the description below, unless explicitly stated, a transceiver unit can be exchanged for a transmitter unit.

[0018] In manufacturing a pressure sensor guide wire assembly, the pressure sensor wire and the transceiver unit must be able to be sterilized prior to use, which in practice has produced problems in the cases where an internal battery is present. Conventionally, gas sterilization using ethylene oxide is used for sensor guidewires. Specific precautions for each type of battery need to be taken in order to eliminate the risks of placing a battery connected to an electrical circuit in ethylene oxide. The present invention provides an improved sensor guidewire assembly, which can be sterilized safely and also has environmental advantages.

[0019] For ease of description, examples of the present invention are illustrated in conjunction with an internal pressure sensor mounted in a wireless sensor guidewire assembly. However, it should be noted that it is within the scope of the invention to use a sensor adapted to measure other physiological parameters within the body, such as flow or temperature. It is also within the scope of the present invention to use a wired sensor guidewire assembly. Even though conventional, i.e. non-wireless, sensor guidewire assemblies are powered by an external power source, the present invention can eliminate the dependency on an external power source, or serve as an auxiliary energy source.

[0020] FIG. 1 is a schematic overview illustrating one application of the present invention. The pressure measurement system according to this embodiment of the present invention comprises a pressure sensor wire with a sensor adapted to measure pressure inside a patient, and to provide measured pressure data to an external device. The pressure sensor wire is adapted to be connected, at its proximal end, to a transmitter or transceiver unit adapted to wirelessly communicate via a radio frequency signal with a communication

unit arranged in connection with an external device, in order to transfer measured pressure data to the external device for analysis and display.

[0021] The external device may be a dedicated device or a patient monitoring device, preferably provided with a monitor, or a PC provided with relevant software and external connections to receive and to process the measured data from the pressure measurement system.

[0022] FIG. 2 shows a block diagram schematically illustrating the transceiver unit 10 according to one embodiment of the present invention. As shown in FIG. 1, the transceiver unit is adapted to be connected to the proximal end of a pressure sensor wire provided, at its distal end, with a pressure sensor to measure pressure inside a patient. Preferably, the transceiver unit 10 comprises a sensor signal adapting circuitry 1, a communication module 2, connected to the adapting circuitry 1, that will handle the wireless communication with the communication unit via an antenna 3. The communication is preferably bi-directional, but can also be one-way.

[0023] The measured signal is communicated by the transceiver unit and transferred as a data stream to the communication unit at a prescribed frequency range (in the case where the communication signal is a radio frequency signal). The signal can also be an infrared signal, a light signal, an ultrasound signal or any wirelessly transmitted signal. In FIG. 2, the antenna 3 is illustrated as protruding outside the transceiver unit but may, as an alternative, be integrated into the housing of the transceiver unit. The pressure sensor wire is adapted to be inserted into an elongated aperture 4 of the transceiver unit 10. The aperture 4 is at its inner surface provided with a number of electrical connecting surfaces (not shown) to be connected to electrode surfaces at the proximal end of the pressure sensor wire when inserted into the aperture 4. The transceiver unit 10 can further be provided with a wire fastening means or mechanism (not shown) to firmly fixate the wire when correctly inserted into the aperture, if the transceiver unit is intended to be used as a torque device, as described below. As an alternative, the wire fastening means or mechanism can be constructed to hold the wire securely longitudinally, while allowing free rotation of the wire within the aperture 4.

[0024] When the pressure sensor wire is fixated to the transceiver unit, the unit may be used as a torque device when guiding the pressure sensor wire during insertion into a patient. Preferably the transceiver unit is provided with gripping means or structure 5, e.g. in the form of one or many elongated ribs on the outer surface of the transceiver unit, or by providing the transceiver unit with a roughened surface. In this context it should be mentioned that in the figures, the transceiver unit 10 and corresponding battery pack or holder 6 (described below) are illustrated as having a generally round cross-sectional shape. However, it should be noted that it is within the scope of the invention to provide a transceiver unit and corresponding battery pack/holder with any cross-sectional shape. Using, for example, an octagonal cross-sectional shape, will provide for easier manipulation when using the transceiver unit as a torque device.

[0025] The transceiver unit is further provided with an attachable and detachable battery pack or battery holder 6. The battery holder 6 includes a battery compartment for holding one or more batteries. The battery or batteries may be held such that the battery or batteries can be removed and readily replaced by a user. The battery or batteries may be recharge-

able or non-rechargeable. Notably, the battery pack/holder 6 is delivered separated from the transceiver unit and attached just prior to initiation of the surgical procedure. The battery pack is preferably encapsulated to ensure easy sterilization as well as easy transport, handling and connection. The battery pack 6 can be hermetically sealed if desired. The battery pack 6 is also provided with electrical connecting surfaces 8 constructed so as to fit the corresponding electrical contact members 7 on the transceiver unit 10. The battery pack 6 can be connected to the transceiver unit 10 by any type of electrical connectors to mate electrical connections, such as, but not limited to, those described below.

[0026] In FIG. 2, the connection is illustrated as having extending plugs 7 on the transceiver unit and receiving apertures 8 on the battery pack 6. However, it is within the scope of the present invention to provide the opposite arrangement, i.e. extended plugs on the battery pack and apertures on the transceiver unit. The extended plugs can moreover have any cross-sectional shape, as long as the receiving apertures are adapted to accept the extended plugs. Furthermore, the extended plugs and receiving apertures can be constructed such that the extended plugs snap into place when fully inserted, so as to firmly attach the battery pack 6 to the transceiver unit 10.

[0027] In a further embodiment, illustrated in cross-sectional view in FIG. 3a and in perspective view in FIG. 3b, the electrical connector is provided with a protective seal 9, preferably sealing the connection between the battery pack 6 and the transceiver unit 10 against fluids and other material when connected. The seal 9 is preferably elastic and can comprise rubber, silicone or any other material used to seal openings against penetrating fluids. Furthermore, the seal 9 is provided with an inner diameter slightly smaller than the outer diameter of the transceiver unit 10. The protective seal 9 can be any shape, as long as it seals the section containing electrical connecting surfaces effectively against penetrating material which could potentially short-circuit the connection. In the types of procedures described here, i.e. when using a sensor guidewire, there is normally blood and other fluids present and it is important in such an environment to avoid short-circuiting the system. The protective seal 9 can also be constructed so as to firmly hold the connector in place. Furthermore, the protective seal 9 can function as a shield against accidental contact by the user with the live electrical circuitry.

[0028] A further embodiment is illustrated in FIG. 4. As shown, the electrical connector can comprise electrical connecting surfaces or contact members 17, 18 placed flat against the transceiver unit 20 and the battery pack/holder 16, respectively, which come in contact with each other when the battery pack is connected to the transceiver unit by any attachment means or mechanism (an example of which is described below). Using flat electrical contact members provides for easy cleaning of the connecting surfaces, which is an important characteristic when working with electrical equipment in a wet environment. Here, the connector is provided with a protective seal 19, which can also function to effectively hold the battery pack attached to the transceiver unit 20, and optionally also act as a shield against accidental contact by the user with the live electrical circuitry.

[0029] In addition to using the protective seal as an attachment mechanism using frictional forces, the battery pack or holder can also be attached to the transceiver unit by any fastening mechanism, including the embodiment illustrated in FIG. 5. In this embodiment, the protective seal 29 again

functions as a portion of an attachment means or mechanism. The inside of the protective seal 29 on the battery pack 26 is provided with internal threads 31 adapted to fit external threads 32 located on the transceiver unit 30. This embodiment provides very secure attachment, however the design of the electrical connecting surfaces (not shown in FIG. 5) has to be adapted to a rotating attachment procedure. For example, the flat contact members illustrated in FIG. 4 can be used in this embodiment. Other attachment means or structure besides threads include, but are not limited to, snaps, screws and barbs.

[0030] As already has been explained, gas-sterilization of a sensor and guidewire assembly comprising an energy source connected to an electric circuit involves a certain risk, because typical sterilization gases like, for example, ethylene oxide (ETO) gas are explosive. The present invention comprises means to discourage re-sterilization of a sensor guidewire assembly by preventing re-use of already used sensor guidewire assemblies and battery packs. This can be achieved by either a mechanical solution or a software solution.

[0031] In some embodiments, the means of preventing re-use of the system comprise the battery pack or holder being attached to the transceiver unit by a keying mechanism which prevents subsequent detachment of the battery pack. One such embodiment is illustrated in FIG. 6. Here, the electrical connecting surfaces or contact members 47, 48 of the transceiver unit 40 are designed such that disconnection is impossible without rendering the device visibly unsuitable for use. In FIG. 6, the protruding electrical contact members 47 are easily inserted into the receiving apertures 48 of the battery pack 46, as the protruding contact members 47 can be bent inwards and/or compressed on insertion. However, once in place, the electrical contact members cannot be separated, as the protruding members 47 snap into place when fully inserted. It should be noted that it is within the scope of the present invention to use other designs of the electrical contact members, or the transceiver unit itself, including an optional protective seal as described above, to provide for an attachment mechanism which allows easy attachment, but prevents subsequent detachment of the battery pack from the transceiver unit. Non-limiting examples of such a keying mechanism include snap-locks, barbs, and spring-loaded or other biased attachment locks. Preferably a one-way attachment mechanism is combined with a circuit solution where the sensor is continuously powered by the energy source such that the energy source is drained of energy, which discourage from re-sterilization of a sensor assembly.

[0032] When the battery pack or battery holder 6, 16, 26 has been attached to the transceiver unit, and the communication unit is connected to or integrated into the external device, the system is ready for use. According to one embodiment, the transceiver unit is activated and initiated when the battery pack is correctly attached to the unit. Upon correct attachment of the battery pack, the transceiver unit is powered up and preferably calibrated. In another embodiment, the transceiver unit will then try to establish a radio link connection with the communication unit. This is preferably performed by a conventional handshake procedure in order to identify the transceiver unit. In this embodiment, simply connecting the battery establishes that the connection is correctly made, that the battery is loaded and of the correct type and subsequently ensures that the system is initiated and ready for use, all in one step. In a further embodiment, the transceiver unit indicates

activation, and optionally also successful calibration and/or connection with the communication unit, by e.g. a light or sound signal directly following attachment of the battery pack.

[0033] In yet another embodiment, powering up of the components in the transceiver comprises a software step wherein the system is checked for previous use of the same transceiver unit. If the transceiver unit has been used previously, the system is immediately powered down or otherwise prevented from improper use. This ensures that each single-use transceiver unit, and the connected sensor, is only used as designed (for example, when fully powered batteries are provided).

[0034] Battery packs **6, 16, 26** can comprise one or several batteries. The batteries can be of a non-rechargeable or a rechargeable type. The battery type can be any type in the art, including, but not limited to lithium primary battery, lithium ion (such as lithium iodine, lithium thionyl chloride, lithium carbon monofluoride or lithium silver vanadiumoxide) battery, alkaline manganese battery, other alkaline batteries, nickel cadmium battery, nickel metal hydride battery, mercury oxide battery, silver oxide battery, lead battery, zinc-air battery, carbon zinc battery, zinc manganese battery, manganese dioxide battery, and a capacitor cell.

[0035] Using an attachable and detachable battery pack, allows for an increased freedom in choice of sterilization methods during manufacture, as the energy source is disconnected from the electrical circuit, and the risks of processing live circuitry in the sterilization procedure are obviated. A battery pack according to the present invention, i.e. a battery pack which is not part of a live circuit (in other words, the battery pack is disconnected from any circuitry and therefore no current is flowing), can be sterilized using any sterilization method in the art, including but not limited to gas sterilization, autoclaving, radiation or alcohol treatment. The sterilization method used for the battery pack can be different from the sterilization method used for the transceiver unit and pressure sensor wire because each of these components is readily separable from each other.

[0036] Embodiments of the invention also provide a method of reusing an energy source for a guide wire assembly having a pressure sensor wire and the energy source, the method including (1) sterilizing the pressure sensor wire and (2) recharging and sterilizing the energy source separate from the sterilizing of the pressure sensor wire before the energy source is electrically coupled to the pressure sensor wire.

[0037] Using a detachable battery pack, in addition to making production and sterilization safer, is also positive from an environmental point of view. A battery pack can be transferred from one transceiver unit to another, enabling use of one battery pack for several interventional procedures. Preferably, the battery pack is re-sterilized and optionally recharged before subsequent use. Also, disposal of the battery is made easy when using a detachable battery pack.

[0038] Manufacture of a sensor guide wire entails calibration and testing of the final product before shipping to the user. When producing a sensor guide wire with a detachable battery pack, the manufacturer has the advantage of being able to use an energy source other than the energy source to be used during the surgical procedure for testing and calibrating the sensor during manufacture. Thus, the energy source needed for the surgical procedure is not depleted before initiation of the surgical procedure itself.

[0039] Although the present invention has been described with reference to specific embodiments it will be apparent for those skilled in the art that many variations and modifications can be performed within the scope of the invention as described in the specification and defined with reference to the claims below.

1-25. (canceled)

26. A transmitter unit, comprising:

a portion adapted to be connected to an elongated member provided at its distal end with a sensor, wherein the elongated member is adapted to be inserted into a patient and therein measure a physiological parameter, in order to transfer measured physiological data to an external device,

wherein the transmitter unit comprises a separate attachable energy source and the attachable energy source is enclosed in a holder comprising electrical connecting members for connection to the transmitter unit.

27. A transmitter unit according to claim **26**, wherein the transmitter unit comprises circuitry to prevent re-powering of the sensor after a completed measurement procedure measuring said physiological parameter.

28. A transmitter unit according to claim **27**, wherein said circuitry to prevent re-powering of the sensor comprises an attachment mechanism which prevents subsequent detachment of the energy source after completed attachment.

29. A transmitter unit according to claim **27**, wherein said circuitry to prevent re-powering of the sensor comprises software programming designed to prohibit re-use of the sensor after one completed measurement procedure.

30. A transmitter unit according to claim **26**, wherein the elongated member is a catheter or a guide wire.

31. A transmitter unit according to claim **26**, wherein the transmitter unit further comprises a receiver module, to form a transceiver unit.

32. A transmitter unit according to claim **26**, wherein the transmitter unit is adapted to wirelessly communicate by a communication signal with a communication unit, arranged in connection with the external device.

33. A transmitter unit according to claim **26**, wherein the attachable energy source functions as an auxiliary energy source.

34. A transmitter unit according to claim **26**, wherein the attachable energy source comprises at least one battery.

35. A transmitter unit according to claim **26**, wherein connection between the transmitter unit and attachable energy source comprises a protective seal.

36. A transmitter unit according to claim **35**, wherein the protective seal provides an attachment mechanism between the transmitter unit and the attachable energy source.

37. A transmitter unit according to claim **36**, wherein the attachment mechanism comprises one of the following types: threads, screws, snaps or barbs.

38. A transmitter unit according to claim **35**, wherein the protective seal functions as a shield against accidental contact by a living being with live electrical circuitry.

39. A transmitter unit according to claim **26**, wherein the transmitter unit is activated automatically upon connection of the attachable energy source.

40. A transmitter unit according to claim **26**, wherein the transmitter unit is calibrated automatically upon connection of the attachable energy source.

41. A transmitter unit according to claim **26**, wherein the transmitter unit automatically establishes a communication

link with a communication unit of the external device upon connection of the attachable energy source.

42. A transmitter unit according to claim **39**, wherein a successful outcome is indicated by a light or sound signal.

43. A transmitter unit according to claim **26**, wherein the energy source is a rechargeable energy source.

44. A transmitter unit according to claim **26**, wherein the energy source is selected from the group of lithium primary battery, lithium ion battery, alkaline manganese battery, other alkaline batteries, nickel cadmium battery, nickel metal hydride battery, mercury oxide battery, silver oxide battery, lead battery, zinc-air battery, carbon zinc battery, zinc manganese battery, manganese dioxide battery, and a capacitor cell.

45. A transmitter unit according to claim **26**, wherein the physiological parameter is one or more of pressure, temperature and flow.

46. A transmitter unit according to claim **26**, wherein the holder includes a battery compartment for holding at least one battery such that the battery can be readily replaced by a user.

47. A transmitter unit according to claim **26**, wherein the transmitter unit is adapted to communicate via a wired connection with a communication unit, arranged in connection with the external device.

48. A transmitter unit according to claim **26**, wherein the portion is configured to be attached to a proximal end of the elongated member.

49. A transmitter unit according to claim **26**, wherein the portion comprises an aperture adapted to receive the elongated member.

50. A transmitter unit according to claim **26**, wherein the transmitter unit includes an antenna.

51. A transmitter unit according to claim **26**, wherein the transmitter unit includes sensor signal adapting circuitry.

52. A transmitter unit according to claim **26**, wherein the transmitter unit includes a communication module.

53. A transmitter unit according to claim **40**, wherein a successful outcome is indicated by a light or sound signal.

54. A transmitter unit according to claim **41**, wherein a successful outcome is indicated by a light or sound signal.

* * * * *

专利名称(译)	传感器导线的可拆卸能源		
公开(公告)号	US20100268038A1	公开(公告)日	2010-10-21
申请号	US12/742025	申请日	2008-08-22
[标]申请(专利权)人(译)	SMITH LEIF		
申请(专利权)人(译)	SMITH LEIF		
当前申请(专利权)人(译)	ST.犹达医疗协调中心BVBA		
[标]发明人	SMITH LEIF		
发明人	SMITH, LEIF		
IPC分类号	A61B5/00		
CPC分类号	A61B5/0002 A61B5/0215 A61B5/6851 A61B2560/0214 A61B2560/0443 A61B2562/225 H01R2103/00 H01R13/622 H01R13/6683 H01R13/6691 H01R24/66 H01R24/76 A61M25/09		
其他公开文献	US8974398		
外部链接	Espacenet USPTO		

摘要(译)

为传感器导丝提供具有可附接能量源的发射器单元。发射器单元适于连接到传感器导丝的近端，传感器导丝在其远端设置有传感器以测量患者体内的生理参数。在一些实施例中，发射器单元适于通过通信信号与通信单元无线通信，通信单元与外部设备连接，以便将测量的生理数据传输到外部设备。可附接的能量源可以是具有连接电连接表面的电池组或电池座。优选地，通过保护性密封保护连接免受渗透流体的影响。

