



US 20080027483A1

(19) **United States**

(12) **Patent Application Publication**
Cartledge et al.

(10) **Pub. No.: US 2008/0027483 A1**

(43) **Pub. Date: Jan. 31, 2008**

(54) **IMPLANTABLE DEVICES FOR CONTROLLING THE SIZE AND SHAPE OF AN ANATOMICAL STRUCTURE OR LUMEN**

(60) Provisional application No. 60/406,841, filed on Aug. 29, 2002. Provisional application No. 60/444,005, filed on Jan. 31, 2003. Provisional application No. 60/447,383, filed on Feb. 14, 2003. Provisional application No. 60/462,435, filed on Apr. 12, 2003. Provisional application No. 60/801,861, filed on May 19, 2006.

(75) Inventors: **Richard G. Cartledge**, Fort lauderdale, FL (US); **Leonard Y. Lee**, New York, NY (US); **James I. Fann**, Portola Valley, CA (US); **Josef L. Friedmann**, Scotts Valley, CA (US); **James L. Green**, Fort Lauderdale, FL (US)

Publication Classification

Correspondence Address:
HOGAN & HARTSON LLP
IP GROUP, COLUMBIA SQUARE
555 THIRTEENTH STREET, N.W.
WASHINGTON, DC 20004 (US)

(51) **Int. Cl.**
A61B 17/08 (2006.01)
A61B 17/00 (2006.01)
A61B 17/58 (2006.01)
A61B 5/00 (2006.01)
(52) **U.S. Cl.** **606/201**; 600/301; 606/100;
606/151

(73) Assignee: **MitralSolutions, Inc.**

(21) Appl. No.: **11/802,264**

(22) Filed: **May 21, 2007**

Related U.S. Application Data

(63) Continuation-in-part of application No. 10/651,840, filed on Aug. 29, 2003, now Pat. No. 7,297,150.

(57) **ABSTRACT**

An implantable device system for controlling the dimensions of internal anatomic passages corrects physiologic dysfunctions resulting from a structural lumen which is either too large or too small. Implantable devices are disclosed which employ various mechanisms for adjusting and maintaining the size of an orifice to which they are attached. Systems permit the implants to be implanted using minimally invasive procedures and permit final adjustments to the dimensions of the implants after the resumption of normal flow of anatomic fluids in situ.

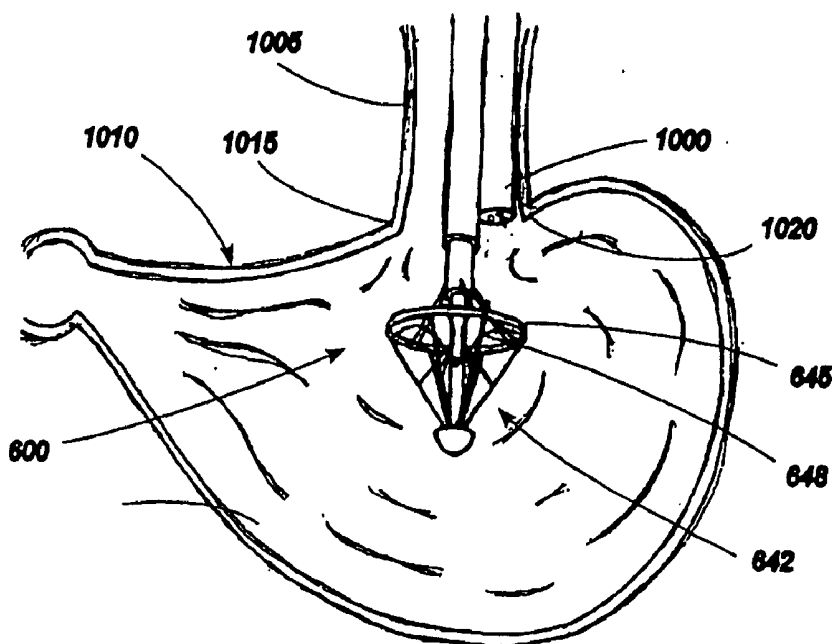

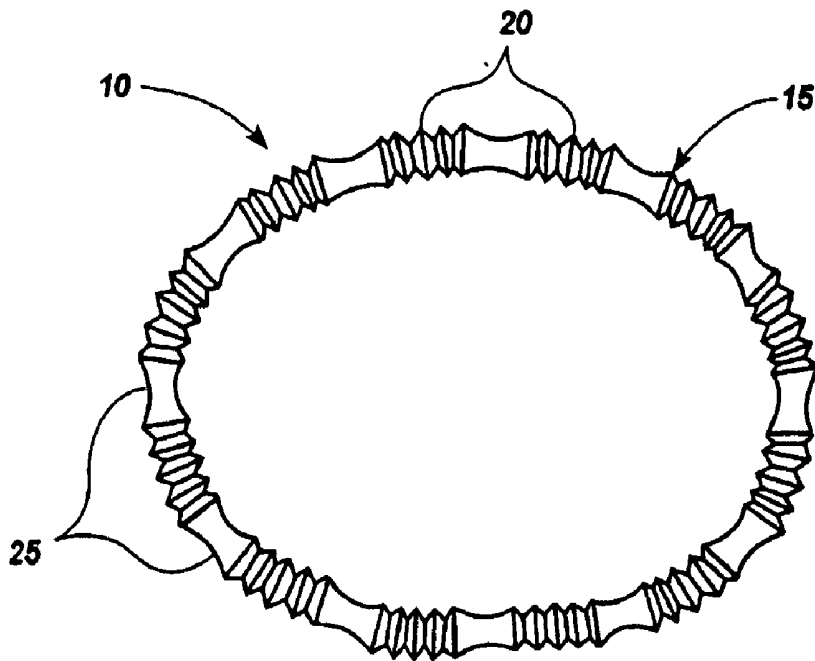

Fig. 1

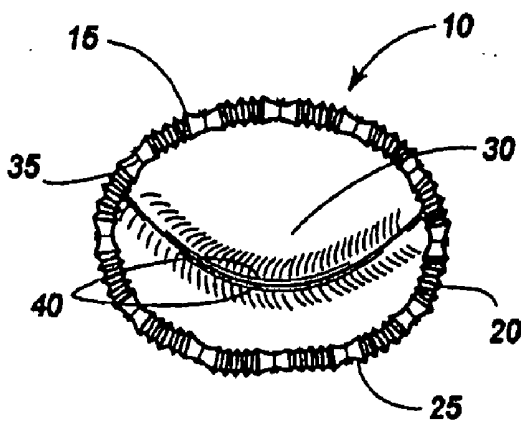

Fig. 2

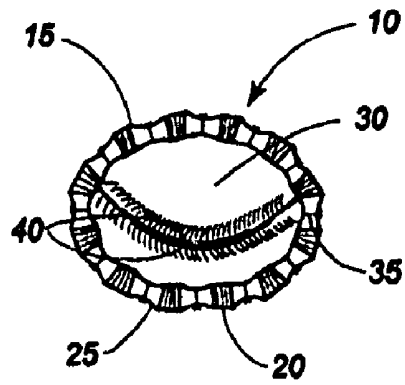

Fig. 3

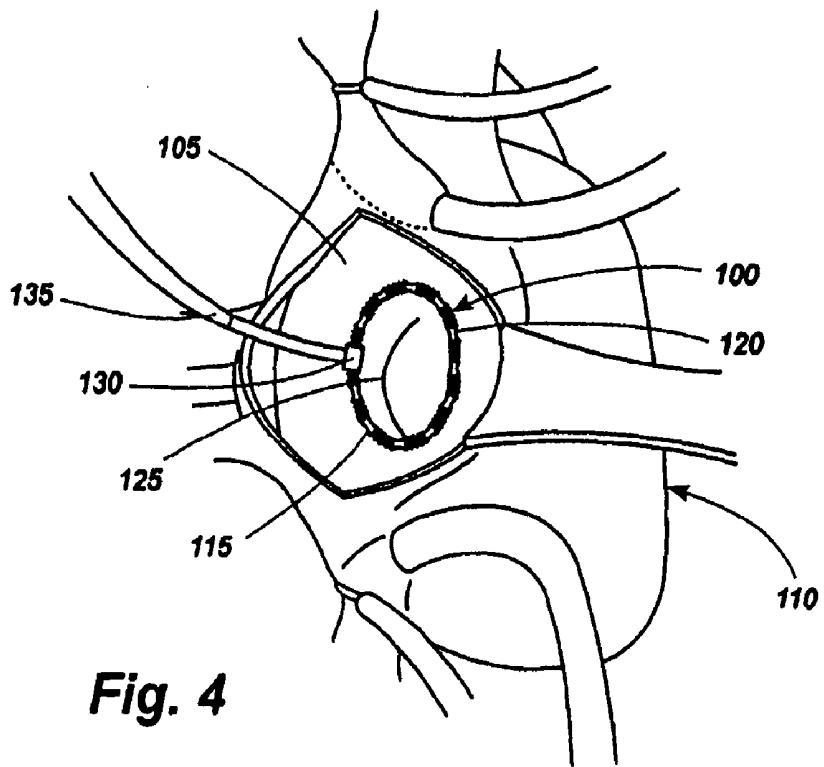

Fig. 4

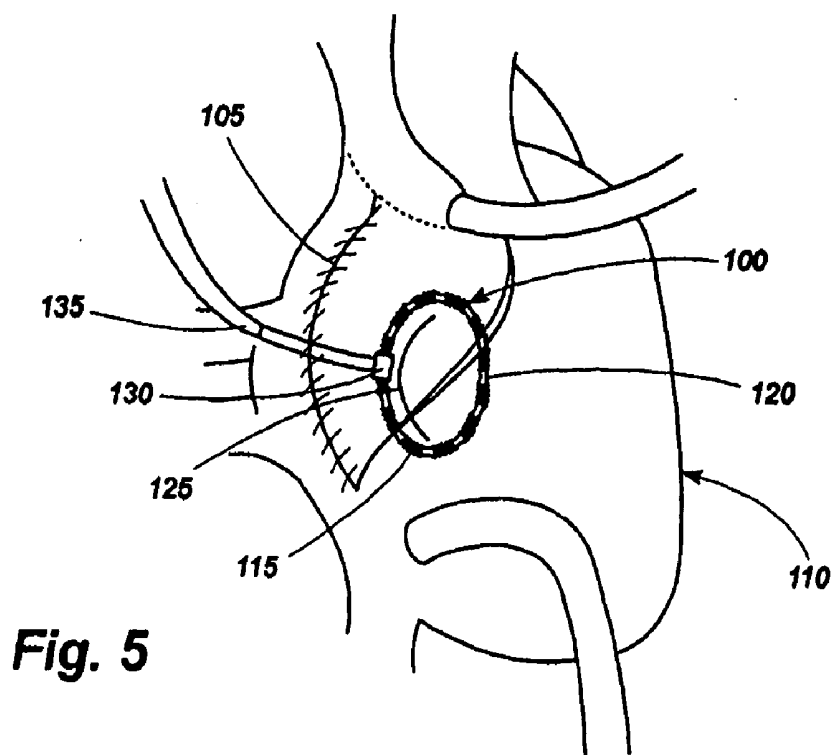
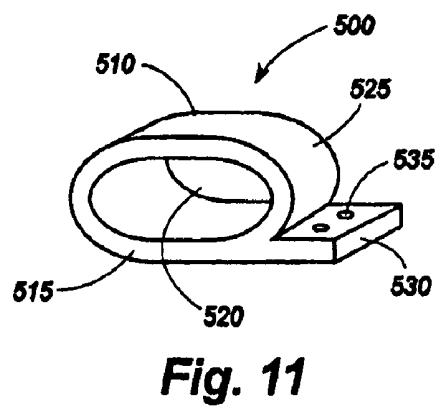
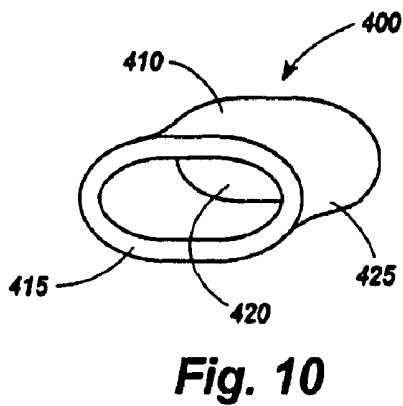
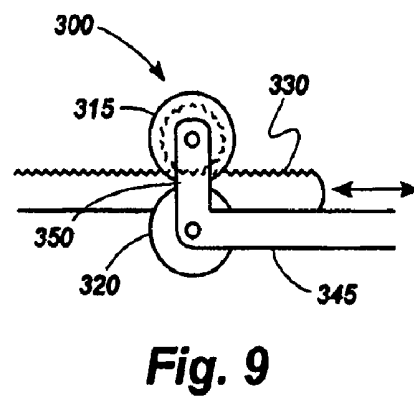
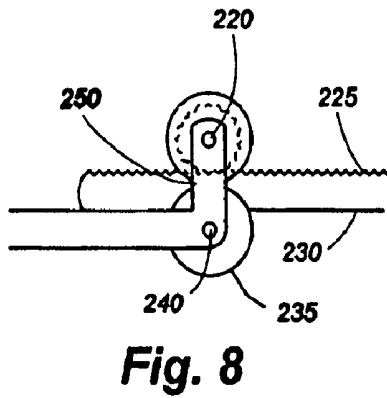
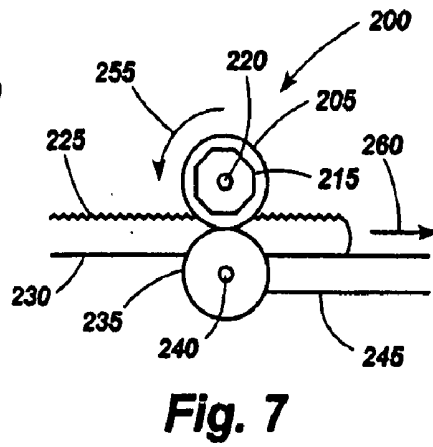
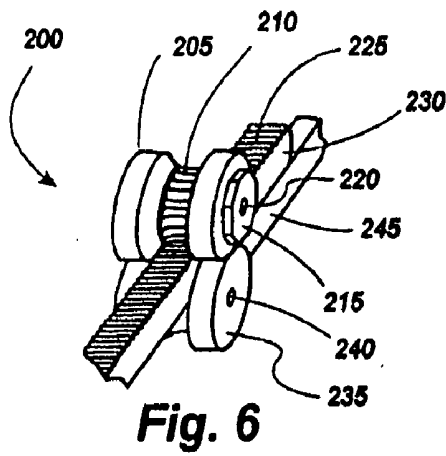

Fig. 5



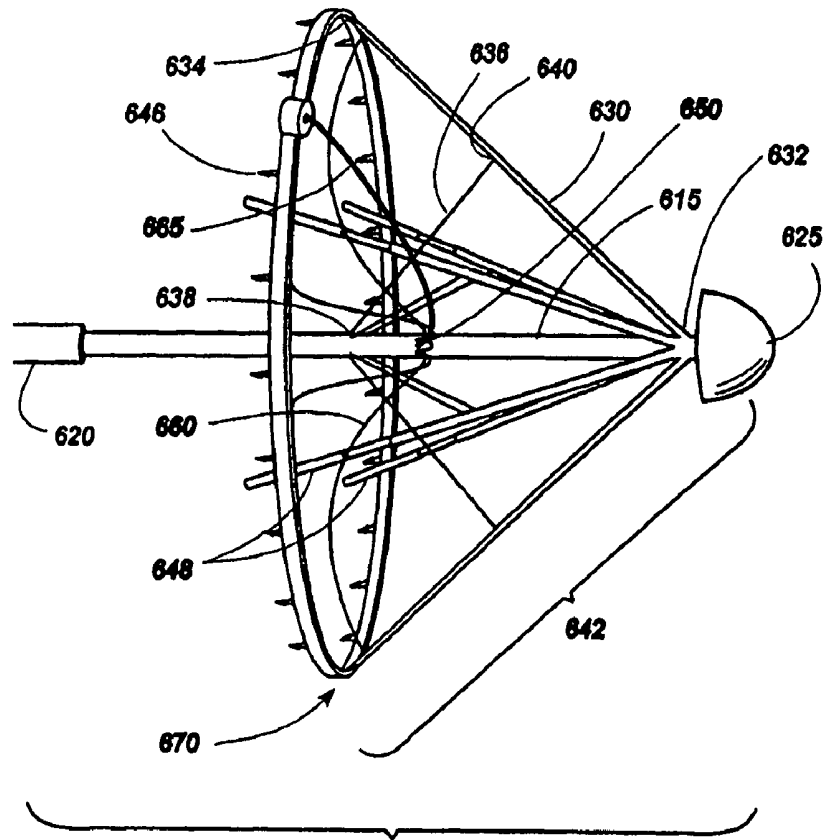

Fig. 12

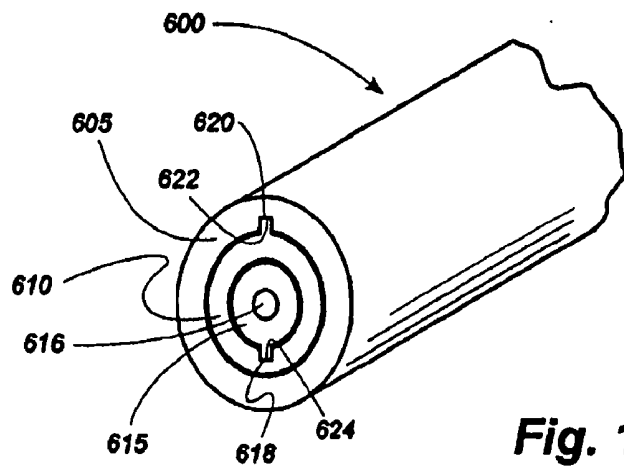
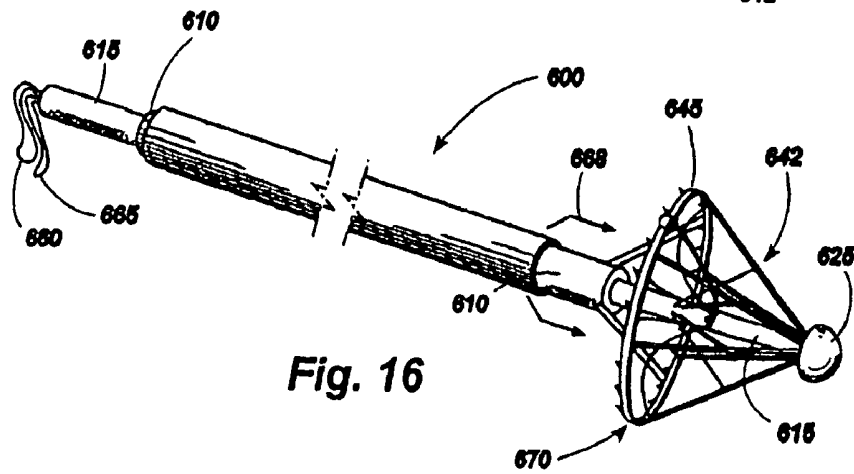
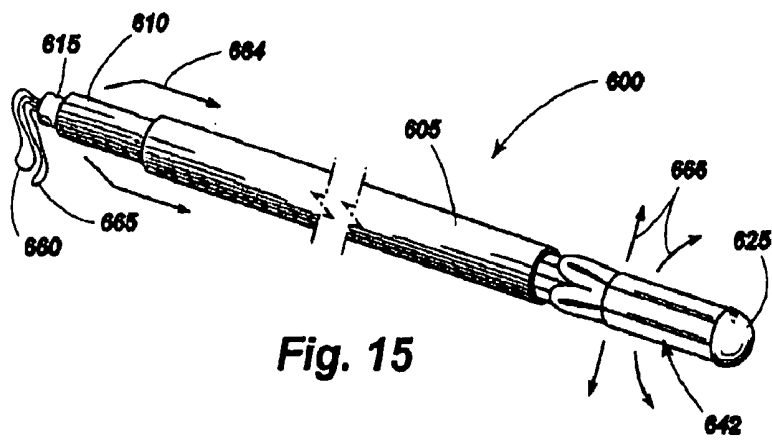
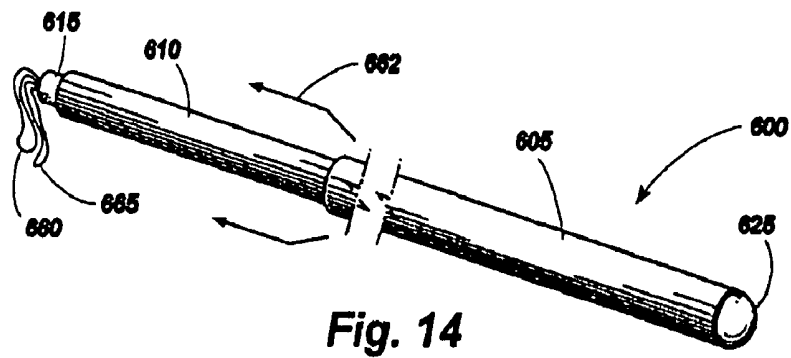

Fig. 13



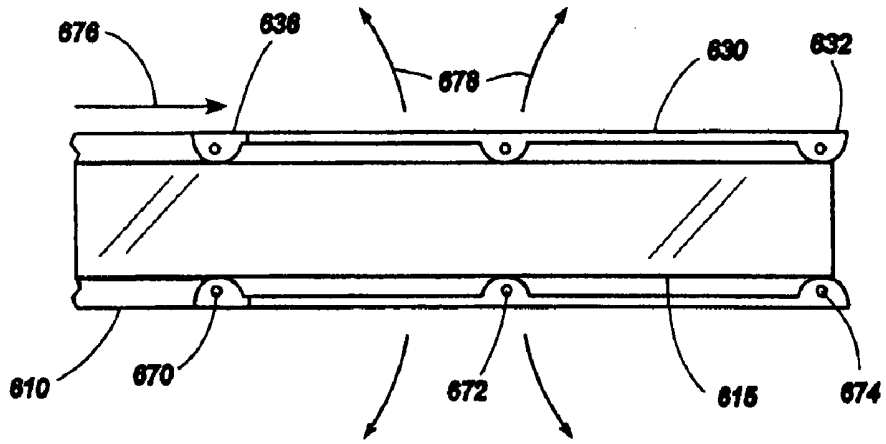

Fig. 17

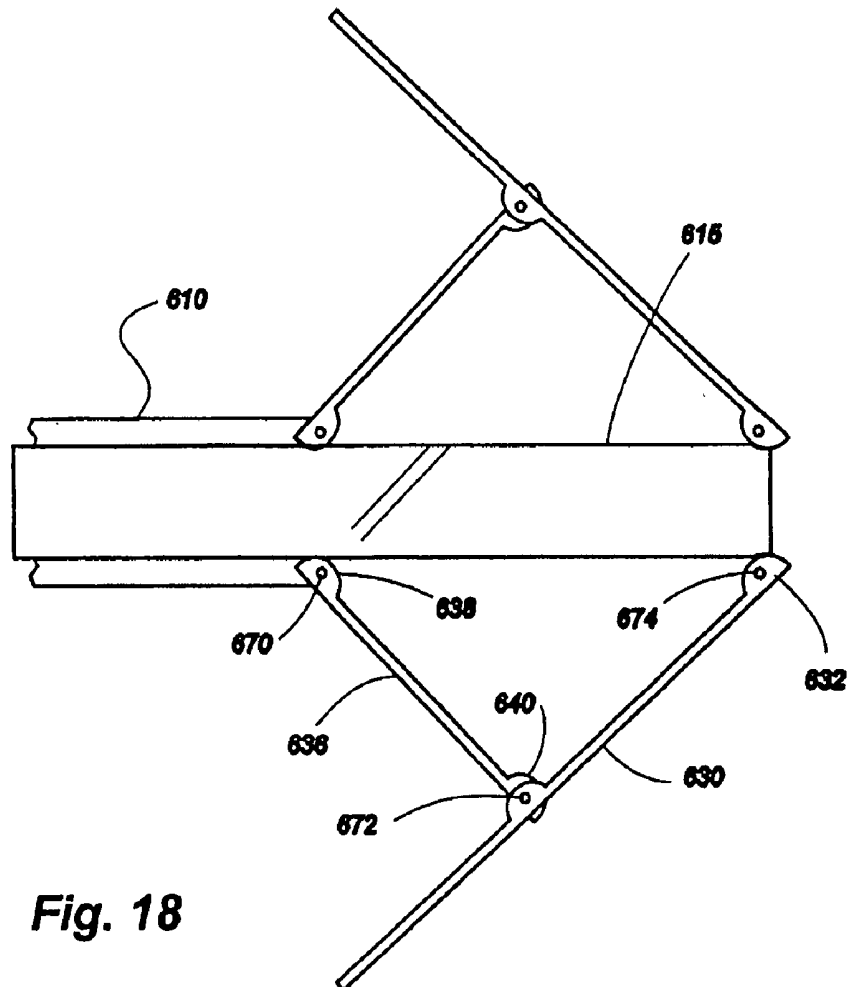
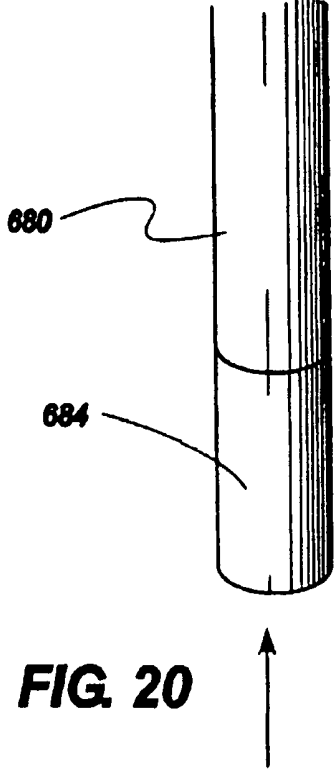
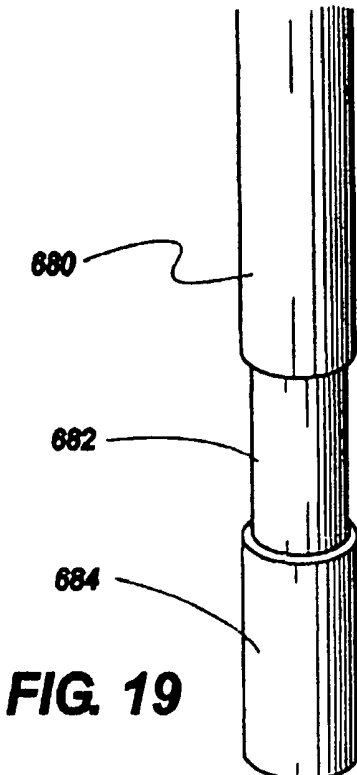
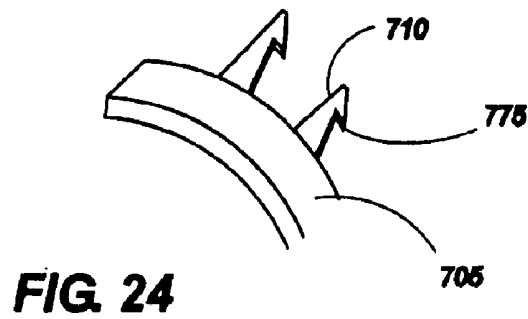
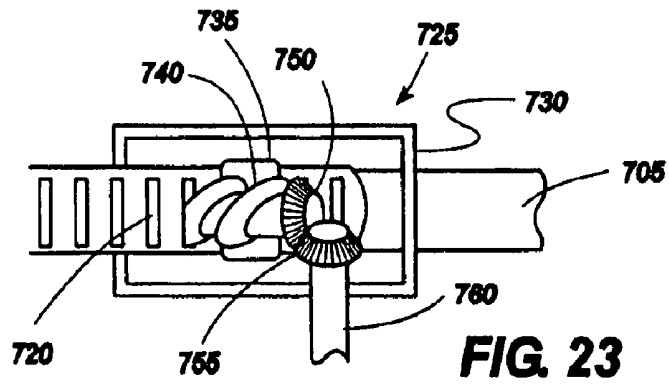
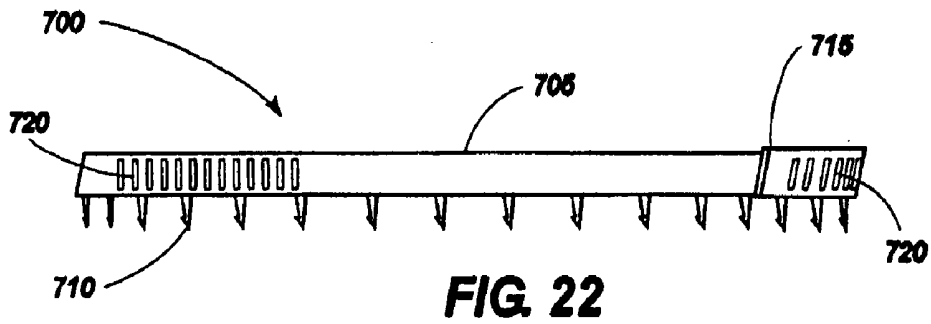
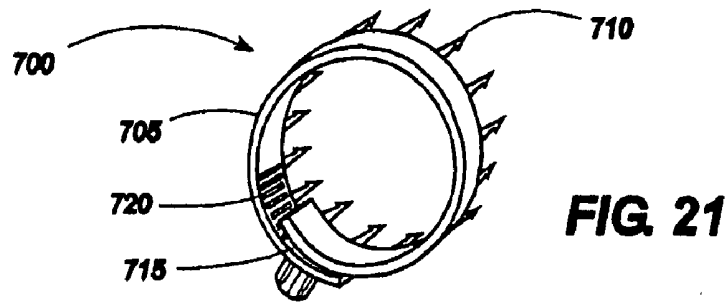

Fig. 18





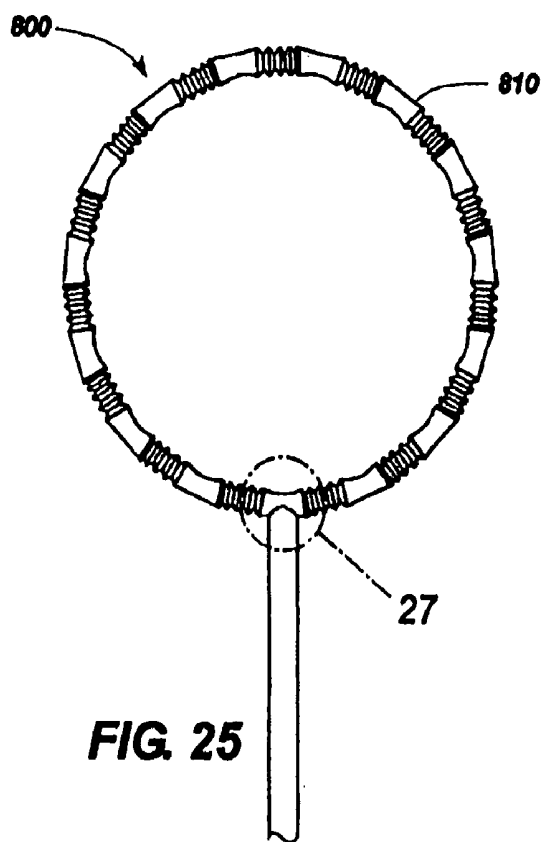

FIG. 25

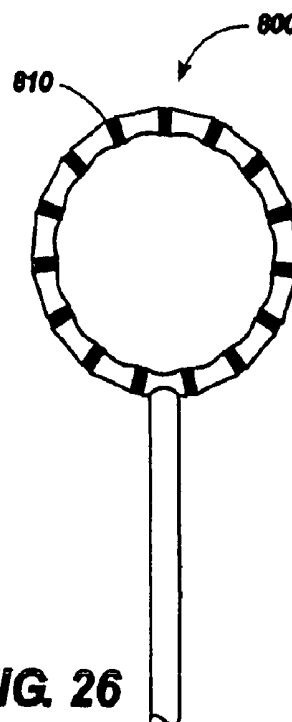

FIG. 26

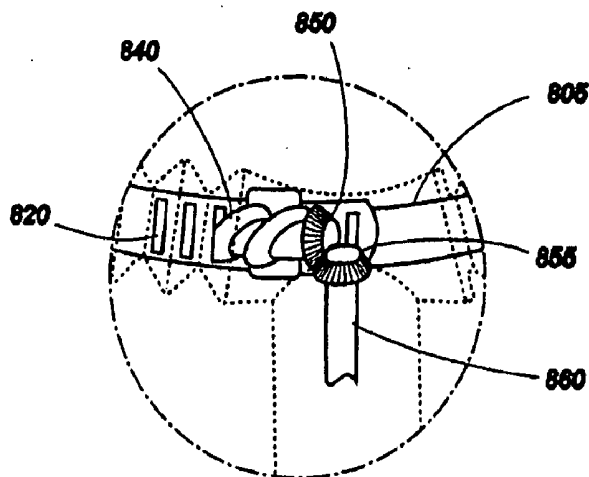

FIG. 27

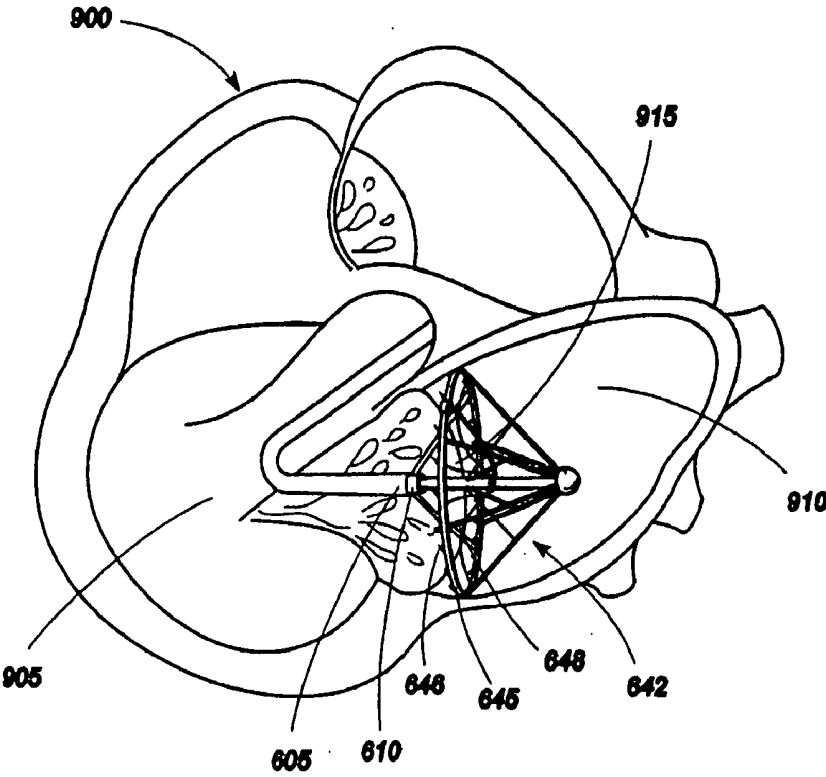
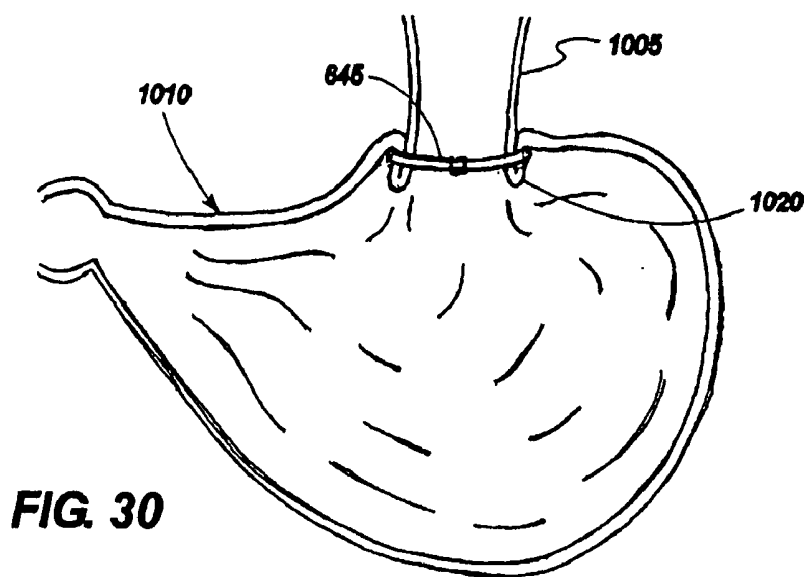
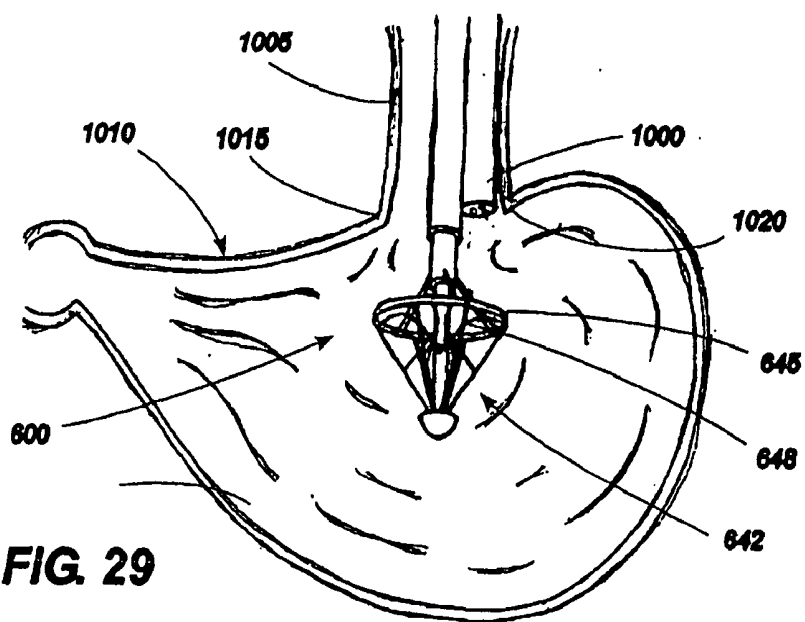

FIG. 28



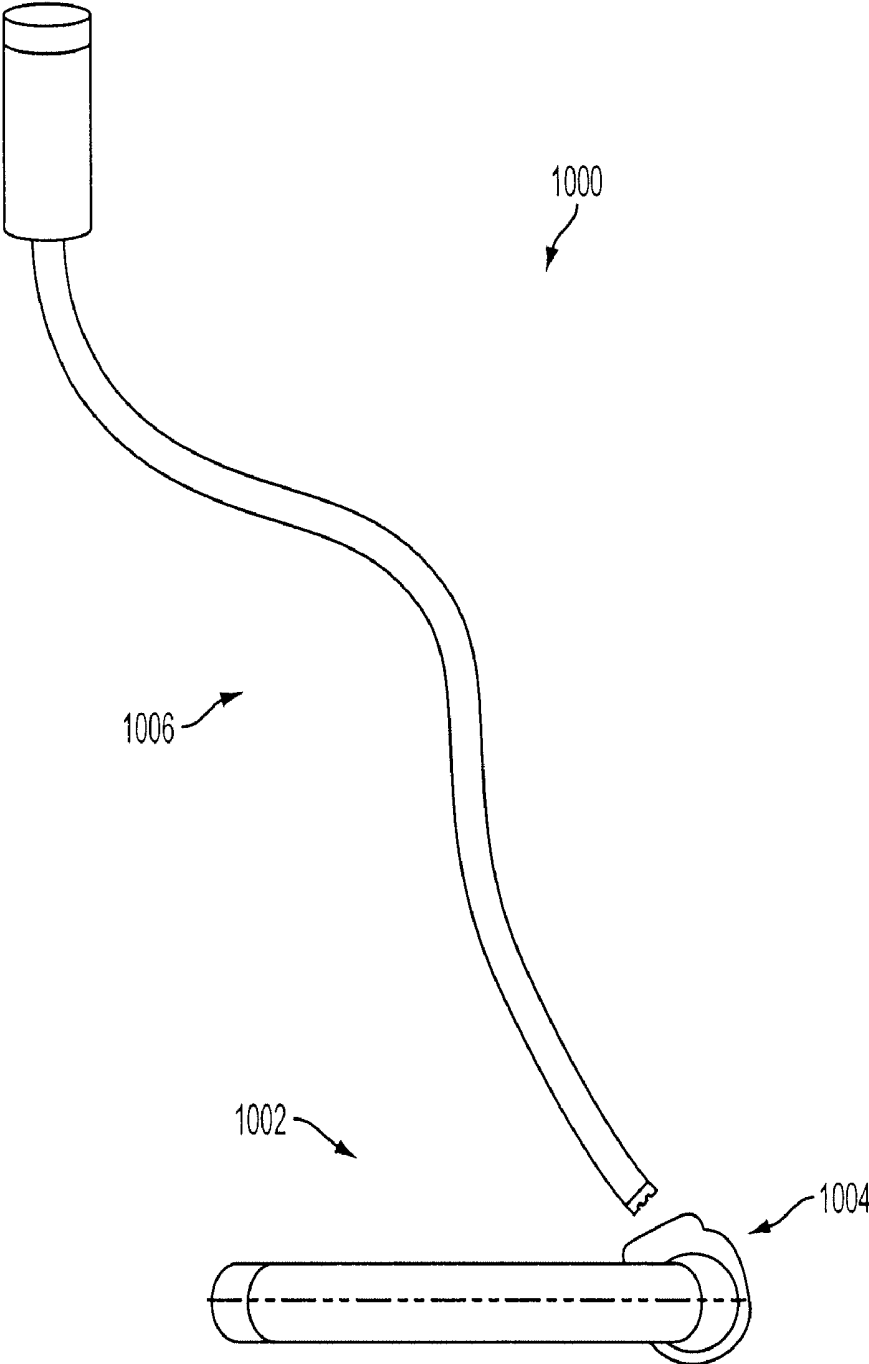

FIG. 31

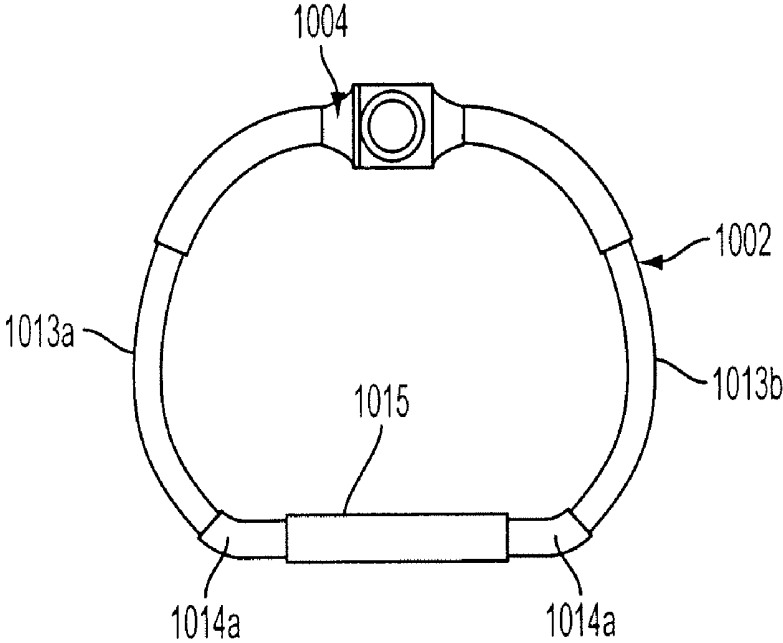

FIG. 32A

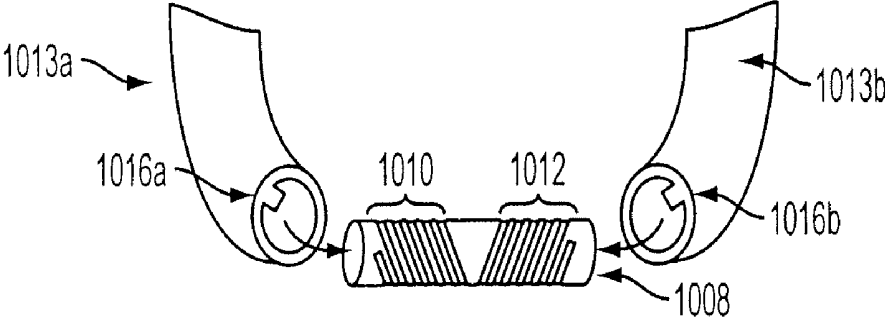

FIG. 32B

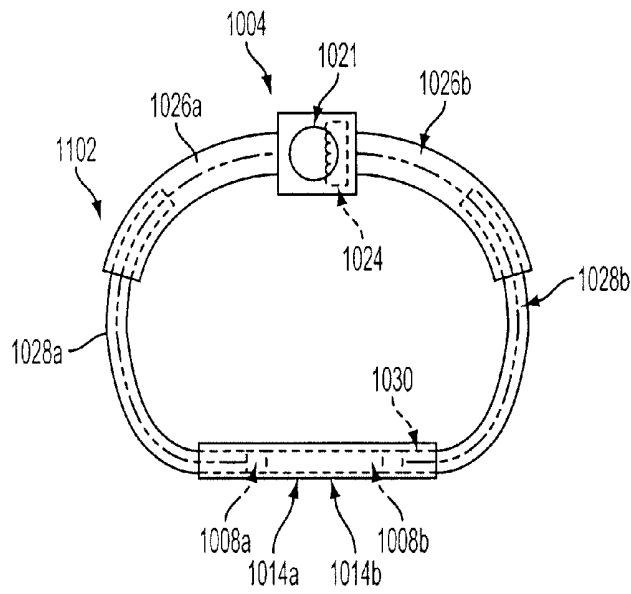

FIG. 33

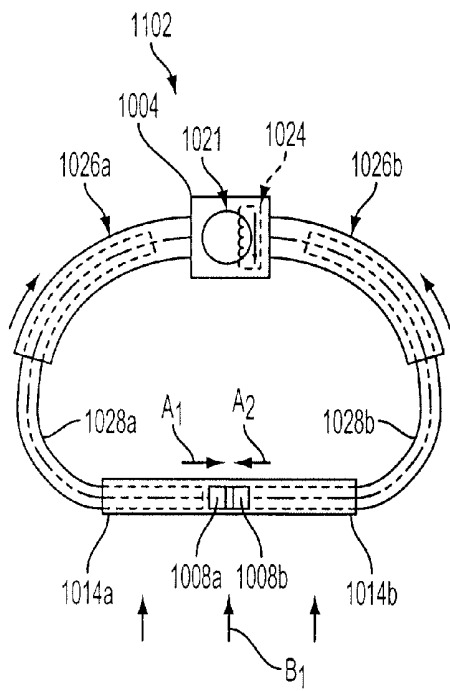

FIG. 34

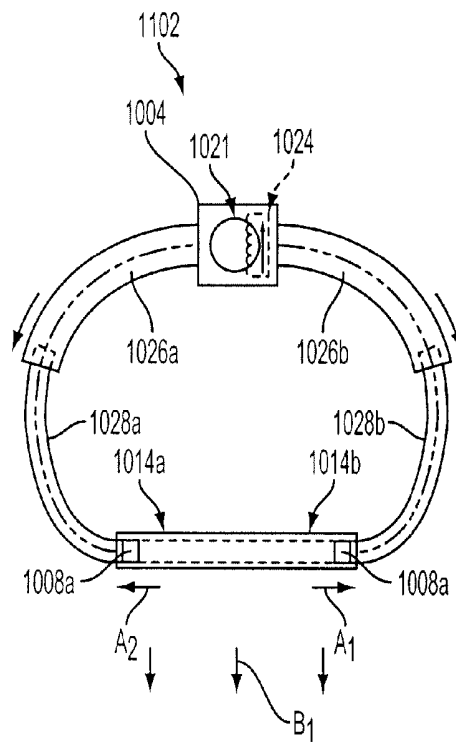

FIG. 35

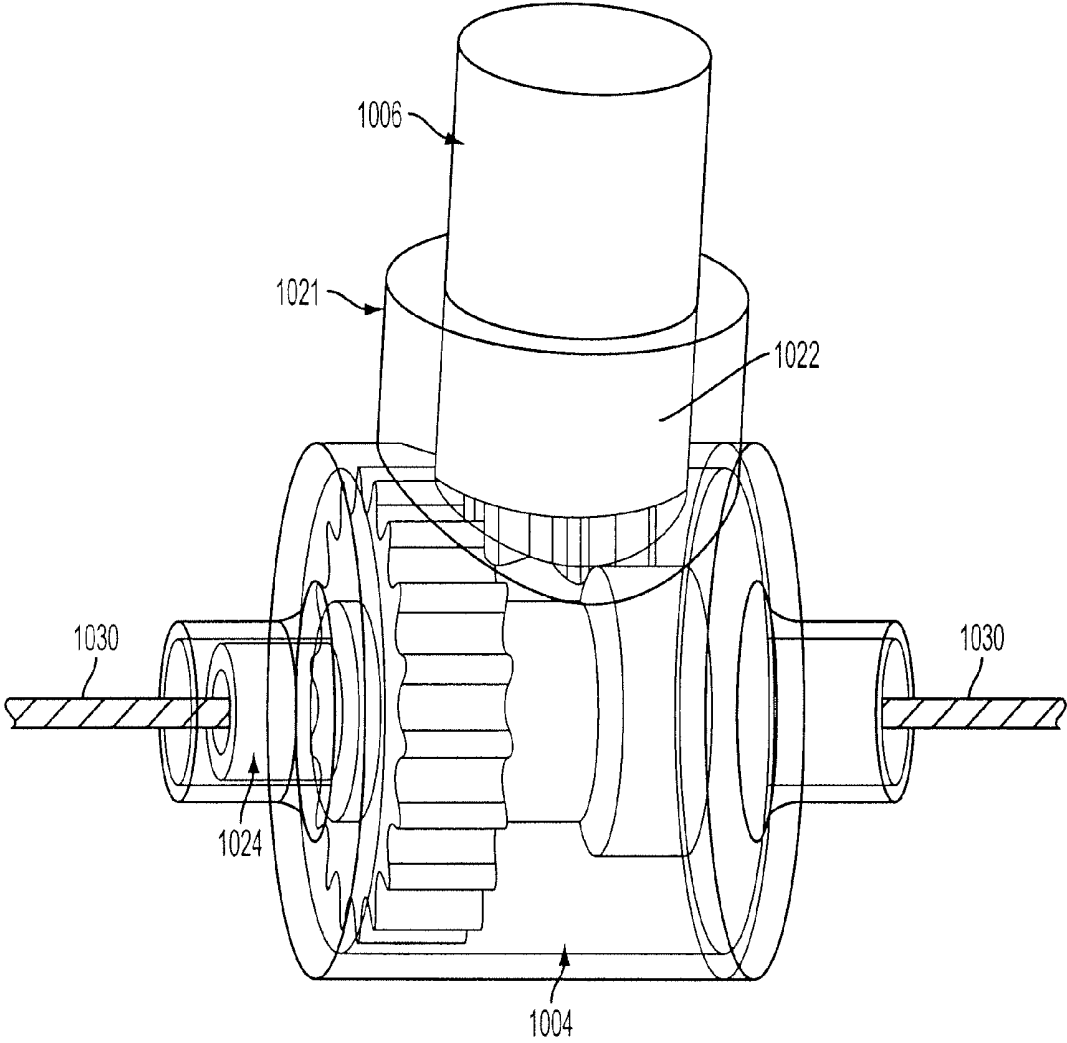

FIG. 36

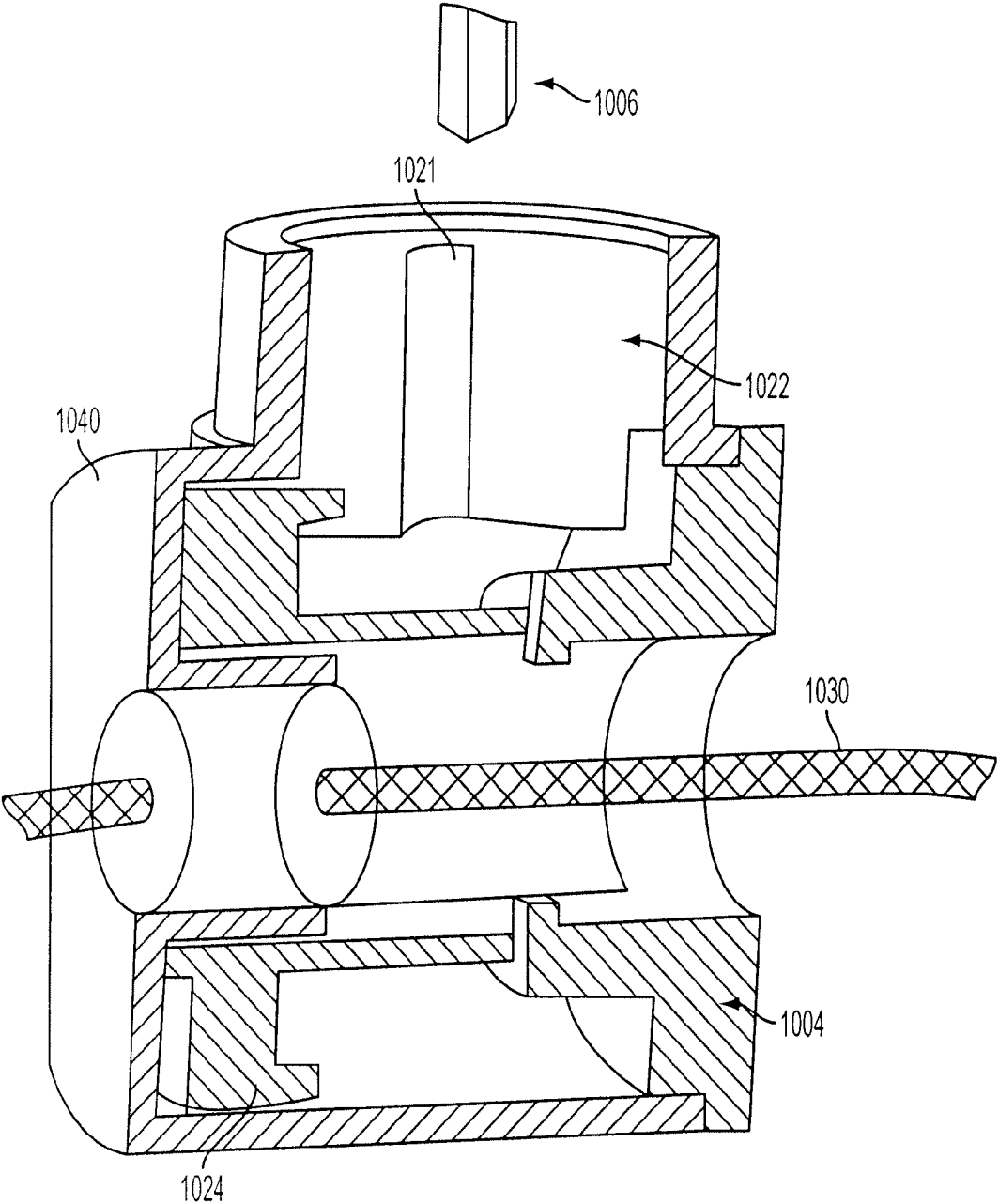

FIG. 37

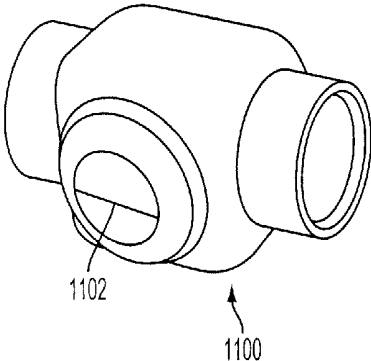

FIG. 40

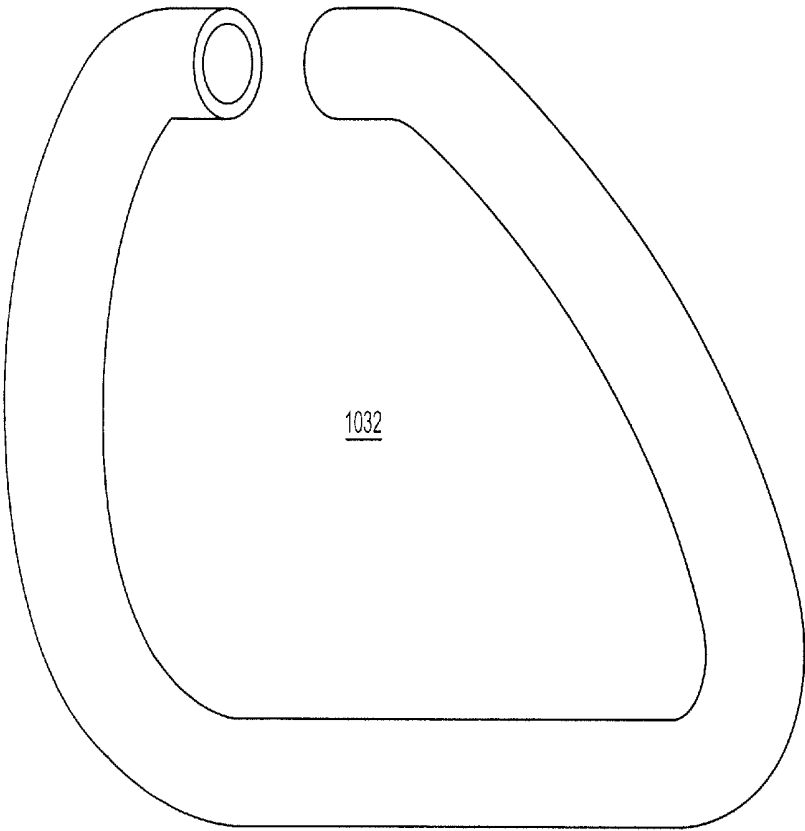

FIG. 38

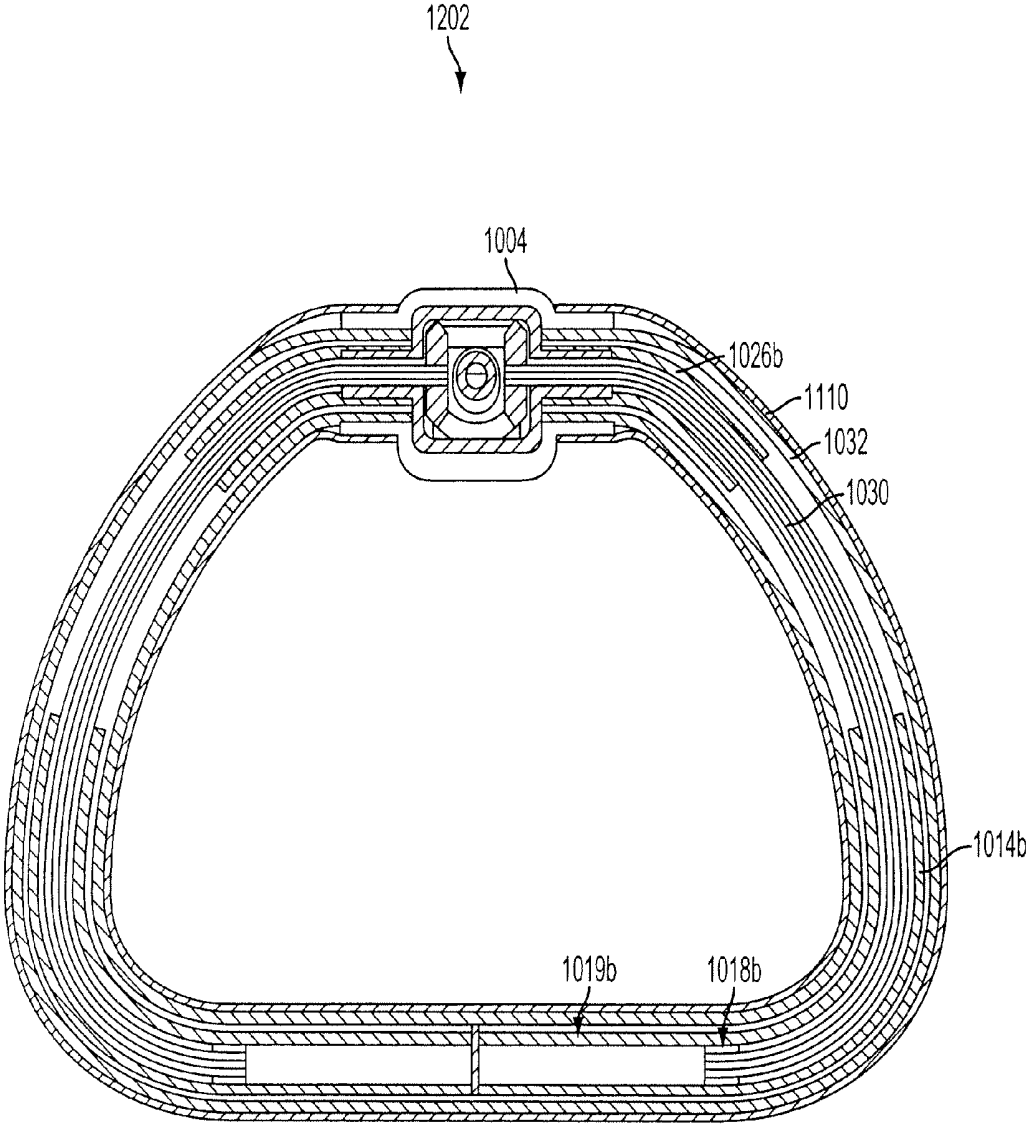

FIG. 39

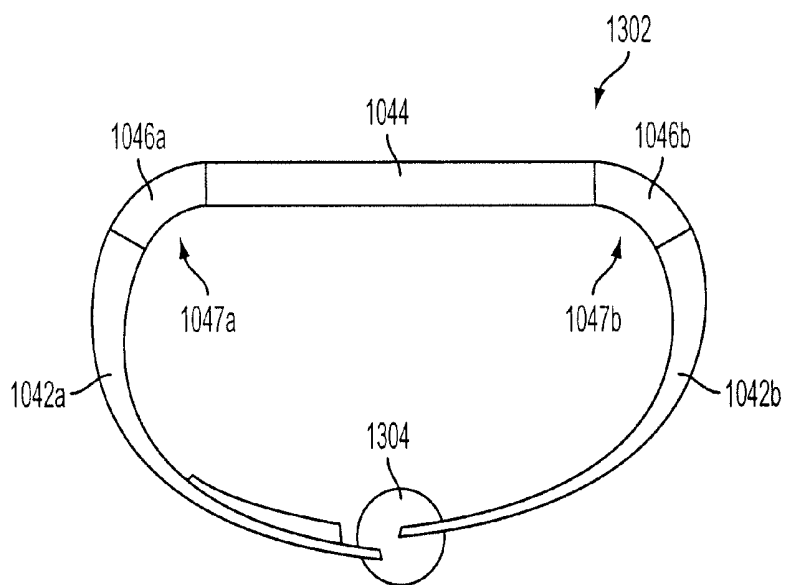

FIG. 41

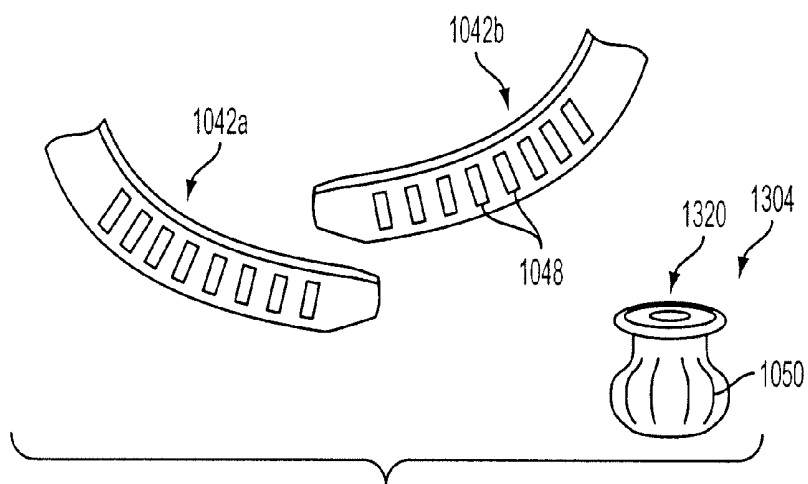

FIG. 42

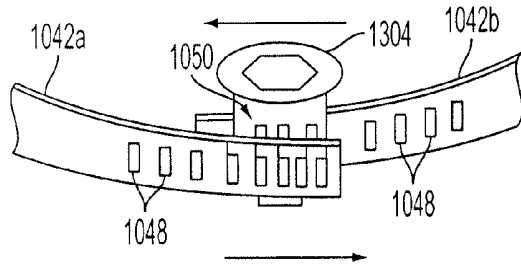

FIG. 43

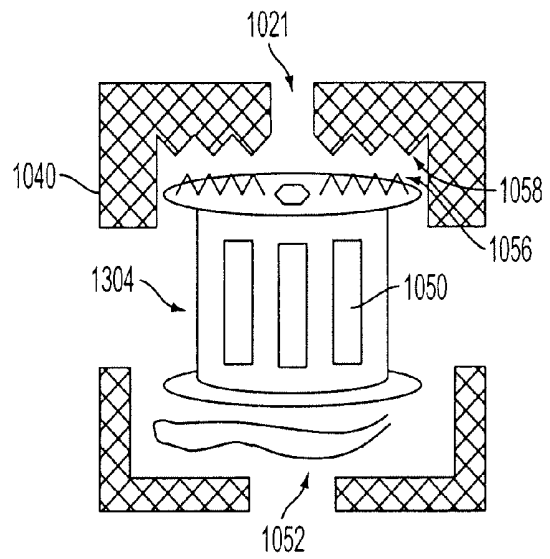

FIG. 44

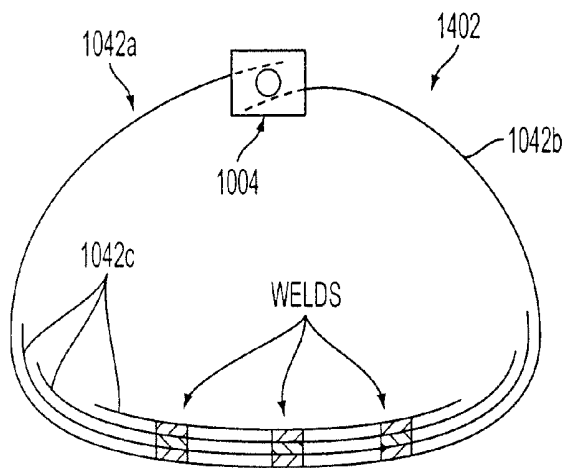

FIG. 45

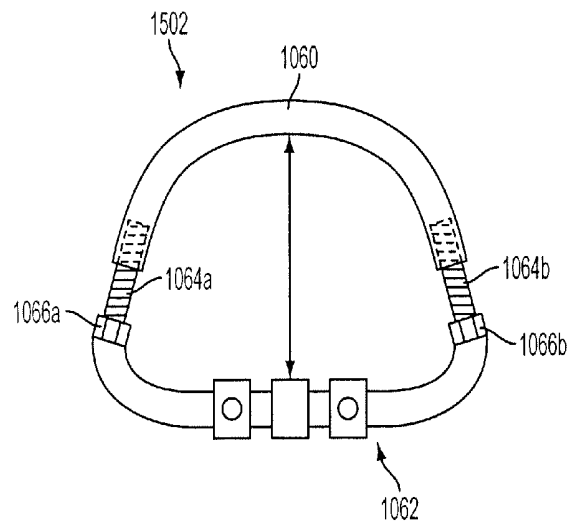

FIG. 46

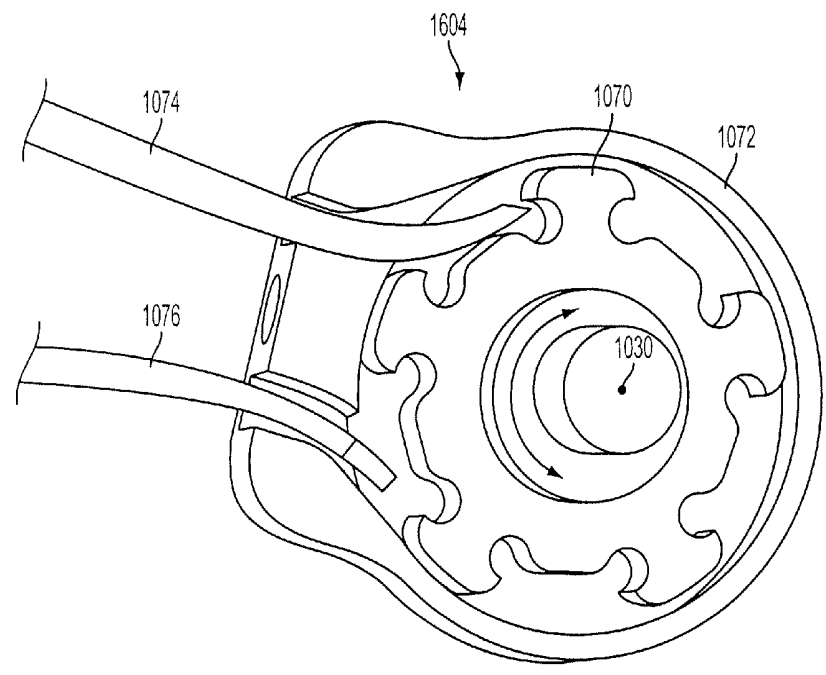

FIG. 47

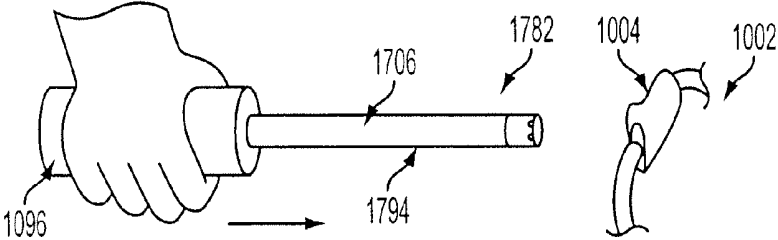

FIG. 48

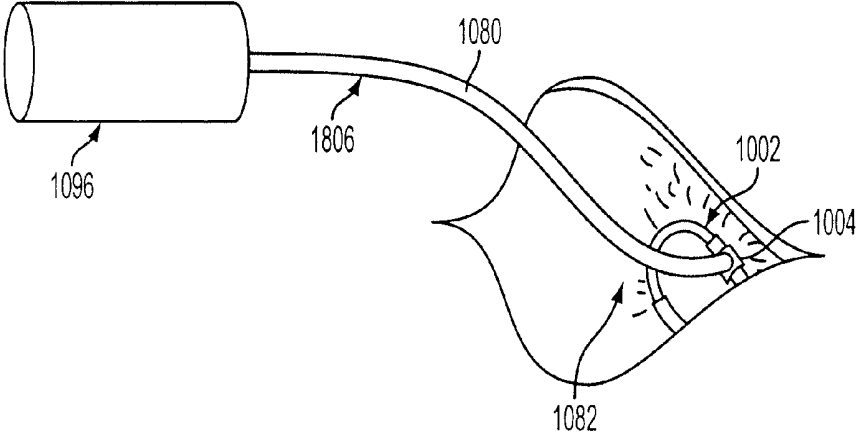

FIG. 49

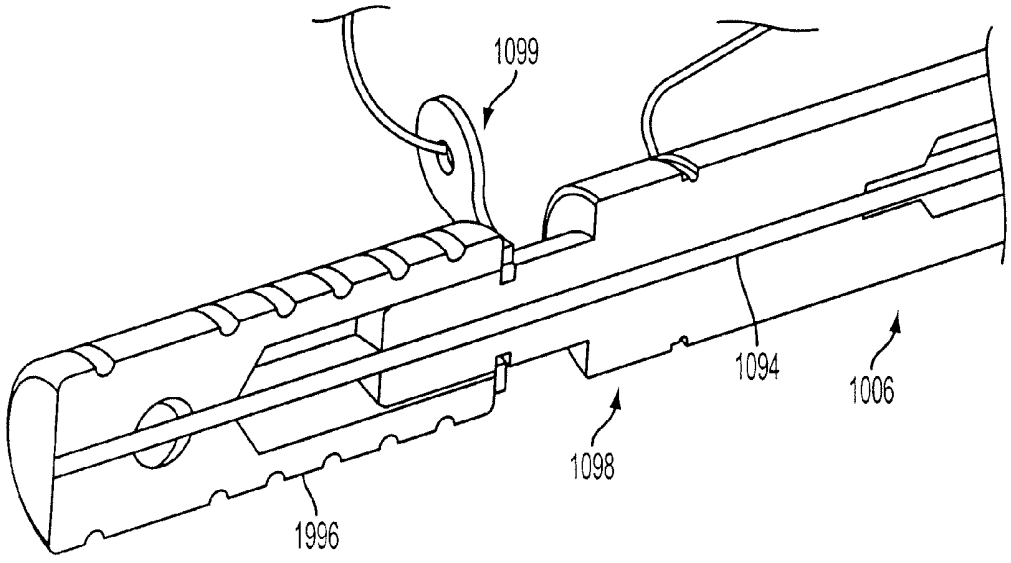

FIG. 50

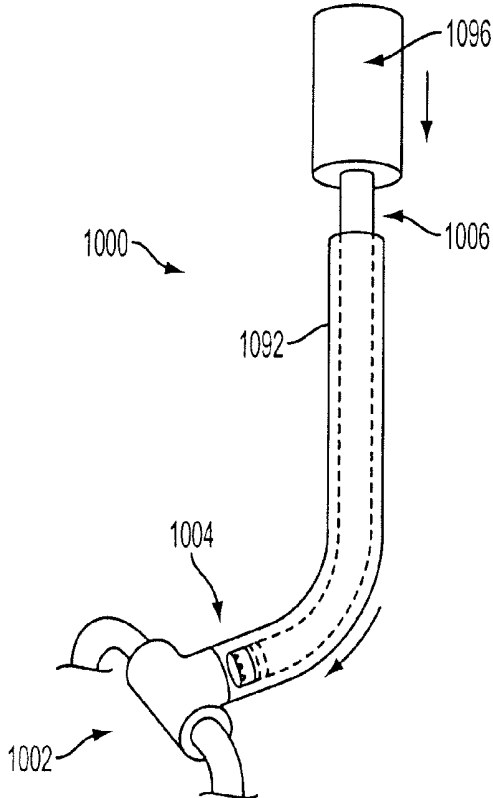

FIG. 51

**IMPLANTABLE DEVICES FOR CONTROLLING
THE SIZE AND SHAPE OF AN ANATOMICAL
STRUCTURE OR LUMEN**

**CROSS REFERENCE TO RELATED
APPLICATIONS**

[0001] This application is a continuation-in-part of U.S. patent application Ser. No. 10/651,840, filed Aug. 29, 2003, which application claims priority under 35 U.S.C. § 119(e) from U.S. Provisional Patent Application No. 60/406,841 filed Aug. 29, 2002; U.S. Provisional Patent Application No. 60/444,005, filed Jan. 31, 2003; U.S. Provisional Patent Application No. 60/447,383, filed Feb. 14, 2003; and U.S. Provisional Patent Application No. 60/462,435, filed Apr. 12, 2003; all of which are incorporated herein by reference. This application also claims priority under 35 U.S.C. § 119(e) from U.S. Provisional Patent Application No. 60/801,861, filed on May 19, 2006, which is also incorporated herein by reference.

**STATEMENT REGARDING SPONSORED
RESEARCH OR DEVELOPMENT**

[0002] Not Applicable.

REFERENCE TO SEQUENCE LISTING

[0003] Not Applicable.

BACKGROUND OF THE INVENTION

[0004] 1. Field of the Invention

[0005] This invention relates generally to implantable devices for controlling at least one of shape and size of an anatomic structure or lumen.

[0006] 2. Description of Related Art

[0007] There is often a need to reduce the internal circumference of an orifice or other open anatomic structure to narrow or increase the size of the orifice or opening to achieve a desired physiologic effect. Often, such surgical procedures require interruption in the normal physiologic flow of blood, other physiologic fluids, or other structural contents through the orifice or structure. The exact amount of the narrowing or widening required for the desired effect often cannot be fully appreciated until physiologic flow through the orifice or structure is resumed. It would be advantageous, therefore, to have an adjustable means of achieving the narrowing or widening effect, such that the degree of narrowing or widening could be changed after its implantation, and after the resumption of normal flow in situ.

[0008] One example of a dysfunction within an anatomic lumen is in the area of cardiac surgery, and specifically valvular repair. Approximately one million open heart surgical procedures are now performed annually in the United States, and twenty percent of these operations are related to cardiac valves.

[0009] The field of cardiac surgery was previously transformed by the introduction of the pump oxygenator, which allowed open heart surgery to be performed. Valvular heart surgery was made possible by the further introduction of the mechanical ball-valve prosthesis, and many modifications and different forms of prosthetic heart valves have since

been developed. However, the ideal prosthetic valve has yet to be designed, which attests to the elegant form and function of the native heart valve.

[0010] As a result of the difficulties in engineering a perfect prosthetic heart valve, there has been growing interest in repairing a patient's native valve. These efforts have documented equal long-term durability to the use of mechanical prostheses, with added benefits of better ventricular performance due to preservation of the subvalvular mechanisms and obviation of the need for chronic anticoagulation. Mitral valve repair has become one of the most rapidly growing areas in adult cardiac surgery today.

[0011] Mitral valve disease can be subdivided into intrinsic valve disturbances and pathology extrinsic to the mitral valve ultimately affecting valvular function. Although these subdivisions exist, many of the repair techniques and overall operative approaches are similar in the various pathologies that exist.

[0012] Historically, most valvular pathology was secondary to rheumatic heart disease, a result of a streptococcal infection, most commonly affecting the mitral valve, followed by the aortic valve, and least often the pulmonary valve. The results of the infectious process are mitral stenosis and aortic stenosis, followed by mitral insufficiency and aortic insufficiency. With the advent of better antibiotic therapies, the incidence of rheumatic heart disease is on the decline, and accounts for a smaller percentage of valvular heart conditions in the developed world of the present day. Commissurotomy of rheumatic mitral stenosis was an early example of commonly practiced mitral valve repair outside of the realm of congenital heart defects. However, the repairs of rheumatic insufficient valves have not met with good results due to the underlying valve pathology and the progression of disease.

[0013] Most mitral valve disease other than rheumatic results in valvular insufficiency that is generally amenable to repair. Chordae rupture is a common cause of mitral insufficiency, resulting in a focal area of regurgitation. Classically, one of the first successful and accepted surgical repairs was for ruptured chordae of the posterior mitral leaflet. The technical feasibility of this repair, its reproducible good results, and its long-term durability led the pioneer surgeons in the field of mitral valve repair to attempt repairs of other valve pathologies.

[0014] Mitral valve prolapse is a fairly common condition that leads over time to valvular insufficiency. In this disease, the plane of coaptation of the anterior and posterior leaflets is "atrialized" relative to a normal valve. This problem may readily be repaired by restoring the plane of coaptation into the ventricle.

[0015] The papillary muscles within the left ventricle support the mitral valve and aid in its function. Papillary muscle dysfunction, whether due to infarction or ischemia from coronary artery disease, often leads to mitral insufficiency (commonly referred to as ischemic mitral insufficiency). Within the scope of mitral valve disease, this is the most rapidly growing area for valve repair. Historically, only patients with severe mitral insufficiency were repaired or replaced, but there is increasing support in the surgical literature to support valve repair in patients with moderate insufficiency that is attributable to ischemic mitral insuffi-

ciency. Early aggressive valve repair in this patient population has been shown to increase survival and improve long-term ventricular function.

[0016] In addition, in patients with dilated cardiomyopathy the etiology of mitral insufficiency is the lack of coaptation of the valve leaflets from a dilated ventricle. The resultant regurgitation is due to the lack of coaptation of the leaflets. There is a growing trend to repair these valves, thereby repairing the insufficiency and restoring ventricular geometry, thus improving overall ventricular function.

[0017] Two essential features of mitral valve repair are to fix primary valvular pathology (if present) and to support the annulus or reduce the annular dimension using a prosthesis that is commonly in the form of a ring or band. The problem encountered in mitral valve repair is the surgeon's inability to fully assess the effectiveness of the repair until the heart has been fully closed, and the patient is weaned off cardiopulmonary bypass. Once this has been achieved, valvular function can be assessed in the operating room using transeophageal echocardiography (TEE). If significant residual valvular insufficiency is then documented, the surgeon must re-arrest the heart, re-open the heart, and then re-repair or replace the valve. This increases overall operative, anesthesia, and bypass times, and therefore increases the overall operative risks.

[0018] If the prosthesis used to reduce the annulus is larger than the ideal size, mitral insufficiency may persist. If the prosthesis is too small, mitral stenosis may result.

[0019] The need exists, therefore, for an adjustable prosthesis that would allow a surgeon to adjust the annular dimension in situ in a beating heart under TEE guidance or other diagnostic modalities to achieve optimal valvular sufficiency and function.

[0020] Cardiac surgery is but one example of a setting in which adjustment of the annular dimension of an anatomic orifice in situ would be desirable. Another example is in the field of gastrointestinal surgery, where the Nissen fundoplication procedure has long been used to narrow the gastro-esophageal junction for relief of gastric reflux into the esophagus. In this setting, a surgeon is conventionally faced with the tension between creating sufficient narrowing to achieve reflux control, but avoiding excessive narrowing that may interfere with the passage of nutrient contents from the esophagus into the stomach. Again, it would be desirable to have a method and apparatus by which the extent to which the gastro-esophageal junction is narrowed could be adjusted in situ to achieve optimal balance between these two competing interests.

[0021] Aside from the problem of adjusting the internal circumference of body passages in situ, there is often a need in medicine and surgery to place a prosthetic implant at a desired recipient anatomic site. For example, existing methods proposed for percutaneous mitral repair include approaches through either the coronary sinus or percutaneous attempts to affix the anterior mitral leaflet to the posterior mitral leaflet. Significant clinical and logistical problems attend both of these existing technologies. In the case of the coronary sinus procedures, percutaneous access to the coronary sinus is technically difficult and time consuming to achieve, with procedures which may require several hours to properly access the coronary sinus. Moreover, these proce-

dures employ incomplete annular rings, which compromise their physiologic effect. Such procedures are typically not effective for improving mitral regurgitation by more than one clinical grade. Finally, coronary sinus procedures carry the potentially disastrous risks of either fatal tears or catastrophic thrombosis of the coronary sinus.

[0022] Similarly, percutaneous procedures which employ sutures, clips, or other devices to affix the anterior mitral leaflets to the posterior mitral leaflets also have limited reparative capabilities. Such procedures are also typically ineffective in providing a complete repair of mitral regurgitation. Furthermore, surgical experience indicates that such methods are not durable, with likely separation of the affixed valve leaflets. These procedures also fail to address the pathophysiology of the dilated mitral annulus in ischemic heart disease. As a result of the residual anatomic pathology, no ventricular remodeling or improved ventricular function is likely with these procedures.

[0023] The need exists, therefore, for a delivery system and methods for its use that would avoid the need for open surgery in such exemplary circumstances, and allow delivery, placement, and adjustment of a prosthetic implant to reduce the diameter of such a mitral annulus in a percutaneous or other minimally invasive procedure, while still achieving clinical and physiologic results that are at least the equivalent of the yields of the best open surgical procedures for these same problems.

[0024] The preceding cardiac applications are only examples of some applications according to the present invention. Another exemplary application anticipated by the present invention is in the field of gastrointestinal surgery, where the aforementioned Nissen fundoplication procedure has long been used to narrow the gastro-esophageal junction for relief of gastric reflux into the esophagus. In this setting, a surgeon is conventionally faced with the tension between creating sufficient narrowing to achieve reflux control, but avoiding excessive narrowing that may interfere with the passage of nutrient contents from the esophagus into the stomach. Additionally, "gas bloat" may cause the inability to belch, a common complication of over-narrowing of the GE junction. An adjustable prosthetic implant according to the present invention could allow in situ adjustment in such a setting under physiologic assessment after primary surgical closure.

[0025] Such an adjustable prosthetic implant according to the present invention could be placed endoscopically, percutaneously, or with an endoscope placed within a body cavity or organ, or by trans-abdominal or trans-thoracic approaches. In addition, such an adjustable prosthetic implant according to the present invention could be coupled with an adjustment means capable of being placed in the subcutaneous or other anatomic tissues within the body, such that remote adjustments could be made to the implant during physiologic function of the implant. This adjustment means can also be contained within the implant and adjusted remotely, i.e. remote control adjustment. Such an adjustment means might be capable of removal from the body, or might be retained within the body indefinitely for later adjustment.

[0026] The present invention and the methods for its use anticipate many alternate embodiments in other potential applications in the broad fields of medicine and surgery. Among the other potential applications anticipated accord-

ing to the present invention are adjustable implants for use in the treatment of morbid obesity, urinary incontinence, anastomotic strictures, arterial stenosis, urinary incontinence, cervical incompetence, ductal strictures, and anal incontinence. The preceding discussions are intended to be exemplary embodiments according to the present invention and should not be construed to limit the present invention and the methods for its use in any way.

SUMMARY OF THE INVENTION

[0027] An object of the present invention is to provide an implantable device for controlling at least one of shape and size of an anatomical structure or lumen.

[0028] These and other objects of the present invention are achieved in an implantable device for controlling at least one of shape and size of an anatomical structure or lumen. An implantable device is provided that has an adjustable member configured to adjust the dimensions of the implantable device. In certain embodiments, a torqueable adjustment tool is configured to provide adjustment of the dimensions of the implantable device for a preferred dimension. In other embodiments adjustments for a preferred dimension may be accomplished remotely through activation of internal adjustment mechanisms.

[0029] In another embodiment of the present invention, an implantable device is provided for controlling at least one of shape and size of an anatomical structure or lumen that includes an implantable device has an adjustable member configured to adjust the dimensions of the implantable device, a particularly a preferred dimension. An adjustment tool is configured to provide adjustment of the dimensions of the implantable device, the adjustment tool providing translated motion through rotation.

[0030] In another embodiment of the present invention, an implantable device is provided for controlling at least one of shape and size of an anatomical structure or lumen. An implantable device has an adjustable member configured to adjust the dimensions of the implantable device and includes first and second bands. An adjustment tool is configured to provide adjustment of the dimensions of the implantable device for a preferred dimension.

[0031] In still another embodiment of the present invention, an implantable device is provided for controlling at least one of shape and size of an anatomical structure or lumen. An implantable device has an adjustable member configured to adjust the dimensions of the implantable device. The implantable device has an anterior portion, a posterior portion and dual threads that provide preferential adjustment of one side or the other of the implantable device. An adjustment tool is configured to provide adjustment of the dimensions of the implantable device.

[0032] In yet another embodiment of the present invention, an implantable device controls at least one of shape and size of an anatomical structure or lumen. An implantable device has an adjustable member configured to adjust the dimensions of the implantable device. An adjustment tool is configured to provide adjustment of the dimensions of the implantable device. The adjustment tool provides reciprocating action to provide for the adjustment.

[0033] In another embodiment of the present invention, an implantable device controls at least one of shape and size of

an anatomical structure or lumen. An implantable device has an adjustable member configured to adjust the dimensions of the implantable device. An adjustment tool is configured to provide adjustment of the dimensions of the implantable device. The adjustment tool provides both course adjustment and fine adjustment.

[0034] Other features and advantages of the present invention will become apparent upon reading the following specification, when taken in conjunction with the drawings and the appended claims.

BRIEF DESCRIPTION OF FIGURES

[0035] FIG. 1 is a front view of a first embodiment of an implant for reducing the circumference of an anatomic orifice.

[0036] FIG. 2 is a front view of the implant of FIG. 1 secured to the annulus of a mitral valve, with the implant in an expanded position.

[0037] FIG. 3 is a front view of the implant of FIG. 1 secured to the annulus of a mitral valve, with the implant in a contracted position to reduced the size of the heart valve opening.

[0038] FIG. 4 is a perspective view of a second embodiment of an implant for reducing the circumference of an anatomic orifice, inserted through an open operative cardiac incision and secured around the mitral valve.

[0039] FIG. 5 is a perspective view of the implant of FIG. 4, showing the cardiac incision closed, an adjustment tool extending through the closed incision, and adjustment of the implant possible after the patient has been taken "off pump."

[0040] FIG. 6 is a perspective view of a first embodiment of an adjustment means for adjusting the circumference of an implant for reducing the circumference of an anatomic orifice.

[0041] FIG. 7 is a right side view of the adjustment means of FIG. 6.

[0042] FIG. 8 is a left side view of the adjustment means of FIG. 6.

[0043] FIG. 9 is a right side view of a second embodiment of an adjustment means for adjusting the circumference of an implant for reducing the circumference of an anatomic orifice.

[0044] FIG. 10 is a perspective view of a first alternate embodiment of an attachment means for the implant of FIG. 1.

[0045] FIG. 11 is a perspective view of a second alternate embodiment of an attachment means for the implant of FIG. 1.

[0046] FIG. 12 is a perspective view of a third embodiment of an implant for reducing the circumference of an anatomic orifice.

[0047] FIG. 13 is a perspective view of one end of the implant of FIG. 12 showing an optional keyed relationship between three coaxial cannulae to prevent relative rotation between the three components.

[0048] FIG. 14 is a perspective view of the implant of FIG. 12 showing the outer cannula extended to cover the implant.

[0049] FIG. 15 is a perspective view of the implant of FIG. 12 showing the outer cannula retracted to expose the implant.

[0050] FIG. 16 is a perspective view of the implant of FIG. 12 showing the middle cannula extended to unfold the implant.

[0051] FIGS. 17 and 18 are schematic views illustrating how extension of the middle cannula causes the implant to unfold, where FIG. 17 shows the implant in the folded position, and FIG. 18 shows the implant in the unfolded position.

[0052] FIG. 19 is a perspective view of the lower end of a touchdown sensor of the implant of FIG. 12, showing the sensor in an uncompressed condition.

[0053] FIG. 20 is a perspective view of the lower end of the touchdown sensor of FIG. 19, showing the sensor in a compressed condition.

[0054] FIG. 21 is a perspective end view of a fourth embodiment of an implant for reducing the circumference of an anatomic orifice.

[0055] FIG. 22 is a side view of the implant of FIG. 21 with the implant opened up to show its full length.

[0056] FIG. 23 is a side view of the adjustment mechanism of the implant of FIG. 21.

[0057] FIG. 24 is a close-up view of two of the retention barbs of the implant of FIG. 21.

[0058] FIG. 25 is a front view of a fifth embodiment of an implant for reducing the circumference of an anatomic orifice, with the implant shown in its expanded configuration.

[0059] FIG. 26 is a front view of the implant of FIG. 25, with the implant shown in its contracted configuration.

[0060] FIG. 27 is an enlarged view of the area indicated by the circle 27 in FIG. 25, with the outer body removed to show interior detail.

[0061] FIG. 28 is a schematic view showing the implant of FIG. 12 anatomically positioned at the mitral annulus in a heart with the implant in a fully expanded state.

[0062] FIG. 29 is a schematic view showing the implant of FIG. 12 anatomically positioned at the gastroesophageal opening with the implant in a fully expanded state.

[0063] FIG. 30 is a schematic view showing the implant of FIG. 29 implanted to reduce the circumference of the gastroesophageal opening.

[0064] FIG. 31 is a schematic view of an embodiment of an implantable device of the present invention.

[0065] FIG. 32A is a schematic view of another embodiment of an implantable device of the present invention.

[0066] FIG. 32B is a schematic view of a threaded member in an embodiment of an implantable device of the present invention.

[0067] FIG. 33 is a schematic view of an embodiment of an implantable device of the present invention with an outer tubing and an inner tubing in a relative first position.

[0068] FIG. 34 is a schematic view of an embodiment of an implantable device of the present invention with an outer tubing and an inner tubing in a relative second position.

[0069] FIG. 35 is a schematic view of an embodiment of an implantable device of the present invention with an outer tubing and an inner tubing in a relative third position.

[0070] FIG. 36 is a schematic view of an embodiment of an adjustable member of the present invention, with the distal tip of the adjustment tool coupled to the adjustment member.

[0071] FIG. 37 is a schematic view of an embodiment of an adjustment member of the present invention having an integrated pinion gear.

[0072] FIG. 38 is a schematic view of an embodiment of a flexible tube cover for an implant device.

[0073] FIG. 39 is a cross-section view of an assembled embodiment of an adjustable implant device.

[0074] FIG. 40 is a schematic view of an embodiment of a seal jacket for an adjustable member.

[0075] FIG. 41 is a schematic view of an embodiment of an adjustment band in the implantable member of the present invention.

[0076] FIG. 42 is a disassembled schematic view of part of the adjustment band and adjustment member of FIG. 41.

[0077] FIG. 43 is an assembled view of the adjustment band and adjustment member of FIG. 42.

[0078] FIG. 44 is a schematic view of an embodiment of the gearbox for the adjustment band of FIG. 41.

[0079] FIG. 45 is a schematic view of an embodiment of the implantable device of the present invention with a sliding band that can be opened and closed to effect a preferential shape change.

[0080] FIG. 46 is a schematic view of an embodiment of the implantable device of the present invention with two adjustable screws used to achieve different pulling rates.

[0081] FIG. 47 is a schematic view of an embodiment of the implantable device of the present invention with reciprocating motion and a clover gear.

[0082] FIG. 48 is a schematic view of an embodiment of the implantable device system of the present invention with an adjustment tool having high column strength and stiffness.

[0083] FIG. 49 is a schematic view of an embodiment of the implantable device of the present invention shown in vivo with an adjustment tool having reduced column stiffness.

[0084] FIG. 50 is a cut-away view of an embodiment of the proximal portion of an adjustment tool.

[0085] FIG. 51 is a schematic view of an embodiment of the implantable device of the present invention with an articulated shape.

DETAILED DESCRIPTION OF THE INVENTION

[0086] Referring now to the drawings, in which like numerals indicate like elements throughout the several

views, an exemplary implant **10** comprising an implant body **15** is shown in FIG. 1. The implant body may be provided in a shape and size determined by the anatomic needs of an intended native recipient anatomic site within a mammalian patient. Such a native recipient anatomic site may be, by way of illustration and not by way of limitation, a heart valve, the esophagus near the gastro-esophageal junction, the anus, or other anatomic sites within a mammalian body that are creating dysfunction that might be relieved by an implant capable of changing the size and shape of that site and maintaining a desired size and shape after surgery.

[0087] The implant **10** of FIG. 1 comprises a circular implant body **15** which is provided with adjustable corrugated sections **20** alternating with intervening grommet-like attachment means **25** having narrowed intermediate neck portions. As can be seen in FIGS. 2 and 3, the implant body **15** may be secured to the annulus of a heart valve **30** by a fixation means such as a suture **35** secured over or through the attachment means **25**. The corrugated sections **20** fold and unfold as the circumference of the implant body **15** shortens or lengthens. Adjustment of the implant **10** in situ may decrease the overall size of the heart valve **30**, increasing the coaptation of the valve leaflets **40**, and changing the configuration from that shown in FIG. 2 to that shown in FIG. 3.

[0088] An additional exemplary embodiment **100** of the present invention is shown in FIGS. 4 and 5, with an open operative cardiac incision **105** in a heart **110** shown in FIG. 4, and closure of the cardiac incision **105** in FIG. 5. As shown in FIG. 4, the exemplary adjustable implant **100** according to the present invention comprises an implant body **115** with attachment means **120** that allows fixation to the annulus of a mitral valve **125**. The exemplary adjustable implant **100** is further provided with an adjustment means **130** that is controlled by an attached or coupled adjustment tool **135**. After closure of the myocardial incision **105** in FIG. 5, the adjustment tool **135** remains attached or coupled to the adjustment means **130**, so that the size and shape of the implant **100** may further be affected after physiologic flow through the heart **110** is resumed, but with the chest incision still open. Once the desired shape and function are achieved, the adjustment tool **135** may be disengaged from the adjustment means **130** and withdrawn from the myocardial incision **105**. In various embodiments according to the present invention, the adjustment means **130** may be configured and placed to allow retention by or re-introduction of the adjustment tool **135** for adjustment following closure of the chest incision.

[0089] To use the implant **100** of FIGS. 4 and 5, the physician makes the open operative incision **105** in the heart **110**, as shown in FIG. 4, in the conventional manner. The implant **100**, mounted at the forward end of adjustment tool **135**, is then advanced through the incision **105** and sutured to the annulus of the mitral valve **125**. The adjustment tool **135** is then manipulated, e.g., rotated, depending upon the design of the adjustment means **130**, to cause the adjustment means to reduce the size of the implant body **115**, and hence the underlying mitral valve **125** to which it is sutured, to an approximate size. The myocardial incision **105** can now be closed, as shown in FIG. 5, leaving the adjustment tool extending through the incision for post-operative adjustment.

[0090] Once the patient has been taken "off pump" and normal flow of blood through the heart **110** has resumed, but before the chest incision has been closed, further adjustments to the size of the mitral valve **125** can be made by manipulating the adjustment tool **135**.

[0091] FIGS. 6-8 show an exemplary adjustment means **200** for adjusting the circumference of an annular implant such as the implant **100** previously described. The adjustment means **200** comprises a rack and pinion system in which a first cam **205** with geared teeth **210** and an engagement coupler **215** turns on a first axel **220**. In this example, the first cam **205** engages a geared rack **225** on one or more surfaces of a first band **230**. The first band **230** passes between the first cam **205** and a second cam **235** that turns on a second axel **240** that is joined to a second band **245**. As shown in FIG. 8, the first and second axels **220**, **240** are maintained in suitable spaced-apart relation by means of a bracket **250** formed at the end of the second band **245**.

[0092] The adjustment means **200** is preferably set within a hollow annular implant **100** of the type previously described, though it is possible to use the adjustment means in a stand-alone configuration wherein the first and second bands **230**, **245** are opposing ends of the same continuous annular structure. In either event, to adjust the length of an implant comprising the adjustment means **200**, a tool such as a hex wrench engages the engagement coupler **215** on the first cam **205** and rotates the first cam in a counterclockwise direction as shown in FIG. 7, as indicated by the arrow **255**. Rotation of the first cam **205** causes the teeth **210** to drive the rack **225** to move the first band **230** toward the right, as indicated by the arrow **260** in FIG. 7. This movement of the first band tightens the circumference of the annular implant. If the physician inadvertently adjusts the implant too tight, reversing direction of the engagement coupler **215** will loosen the implant.

[0093] In various embodiments according to the present invention, the first and second bands **230**, **245** may be separate structures, or they may be opposing ends of the same continuous structure. In such an embodiment, when motion is imparted to the engagement coupler **215**, the first cam **205** is rotated, causing the geared teeth **210** to engage the geared rack **225**, and causing the first band **230** to move with respect to the second band **245** to adjust the circumference of an implant.

[0094] FIG. 9 shows a somewhat different configuration of an exemplary engagement means **300** according to the present invention, in which there is no engagement coupler, and a bracket **350** is provided on both sides of the cams to maintain the first cam **315** and the second cam **320** in close approximation. In one proposed embodiment, the bracket is designed with close tolerances so as to press the first band **330** closely against the second band **345**, thereby to hold the bands in fixed relative position by friction. In another proposed embodiment, the brackets **350** are fabricated from an elastic material such that the cams **315**, **320** can be spread apart to insert the first band **330** between the cams, whereupon the cams are pulled back together with sufficient force to hold the bands **330**, **345** in fixed relative position by friction. In still another proposed embodiment involving an elastic mounting arrangement between the cams **315**, **320**, the lower edge of the first band **330** and the upper edge of the second band **345** have mating frictional or mechanical

surfaces, whereby the cams 315, 320 can be spread apart to permit relative movement between the bands or released to clamp the bands together in fixed relation.

[0095] FIG. 10 shows an exemplary attachment means 400 for an implant according to the present invention. The attachment means 400 could be used, for example, in place of the attachment means 25 of the implant 10. The attachment means 400 takes the form of a grommet 410 comprising a wall 415 defining a lumen 420 and an attachment surface 425. Such an attachment means would be used with the implant body extending through the lumen 420 and with fixation devices such as sutures or wires either tied over or affixed through the attachment surface 425.

[0096] FIG. 11 shows another alternate embodiment of an attachment means 500 for an implant according to the present invention. The attachment means 500 could also be used, for example, in place of the attachment means 25 of the implant 10. FIG. 11 shows an attachment means 500 in the form of a hollow tube or tube segment 510 comprising a wall 515 defining a lumen 520, an outer surface 525, and an attachment tab 530. Such an attachment means would be used with the implant body extending through the lumen 520 and with fixation devices such as sutures or wires either tied or otherwise affixed over or through the attachment tab 530. Such fixation devices might be placed through holes 535 provided in the attachment tab 530. Alternately a solid attachment tab 530 might be provided, and the fixation devices might be passed through the solid tab. Modifications of these attachment means may be used in conjunction with a sutureless attachment system.

[0097] FIGS. 12-18 show another embodiment of a percutaneous annuloplasty device according to the present invention, in which an implant/delivery system array 600 includes a housing sheath 605 (not seen in FIG. 12), an actuating catheter 610 coaxially slidably mounted within the housing sheath 605, and a core catheter 615 coaxially slidably mounted within the actuating catheter 610. The core catheter has a central lumen 616 (FIG. 13). The actuating catheter 610 and core catheter 615 may be round tubular structures, or as shown in FIG. 13, either or both of the actuating and core catheters may be provided with one or more keyed ridges 618, 620 respectively to be received by one or more reciprocal slots 622, 624 within the inner lumen of either the housing sheath 605 or the actuating catheter 610, respectively. Such keyed ridges 618, 620 would limit internal rotation of an inner element within an outer element, should such restriction be desirable to maintain control of the inner contents from inadvertent displacement due to undesired rotational motion during use.

[0098] The implant/delivery system array 600 includes a distal tip 625 at the forward end of the core catheter 615. One or more radial implant support arms 630 have their distal ends 632 pivotably or bendably mounted to the core catheter 615 adjacent its distal tip 625. The proximal ends 634 of the radial implant support arms 630 normally extend along the core catheter 615 but are capable of being displaced outward away from the core catheter.

[0099] One or more radial support struts 636 have their proximal ends 638 pivotably or bendably mounted to the distal end of the actuating catheter 610. The distal end 640 of each radial support strut is 636 pivotably or bendably attached to a midpoint of a corresponding radial implant

support arm 630. As the actuating catheter 610 is advanced with respect to the core catheter 615, the radial support struts 636 force the radial implant support arms 630 upward and outward in the fashion of an umbrella frame. Thus the actuating catheter 610, core catheter 615, radial support struts 636, and radial support arms 630 in combination form a deployment umbrella 642.

[0100] A prosthetic implant 645 is releasably attached to the proximal ends 634 of the radial implant support arms 630. Around the periphery of the prosthetic implant 645 and extending proximally therefrom are a plurality of retention barbs 646. In addition, one or more of the radial implant support arms 630 comprise touchdown sensors 648 whose proximal ends extend proximal to the implant 645. Extending through the central lumen 616 (FIG. 13) of the core catheter 615 in the exemplary embodiment 600 and out lateral ports 650 (FIG. 12) spaced proximally from the distal tip 625 are one or more release elements 660, which serve to release the implant 645 from the delivery system, and one or more adjustment elements 665 which serve to adjust the implant's deployed size and effect. Because the release elements 660 and adjustment elements 665 extend through the proximal end of the core catheter 615, as seen in FIGS. 14-16, these elements can be directly or indirectly instrumented or manipulated by the physician. A delivery interface 670 (FIGS. 12, 16) is defined in this example by the interaction of the deployment umbrella 642, the release elements 660, and the implant 645. In the disclosed embodiment, the release elements 660 may be a suture, fiber, or wire in a continuous loop that passes through laser-drilled bores in the implant 645 and in the radial implant support arms 630, and then passes through the length of the core catheter 615. In such an embodiment, the implant 645 may be released from the delivery system at a desired time by severing the release element 660 at its proximal end, outside the patient, and then withdrawing the free end of the release element 660 through the core catheter 610.

[0101] FIGS. 14-16 show the operation of the implant/delivery system array 600, in which an umbrella-like expansion of the prosthetic implant 645 is achieved by sliding movement of the housing sheath 605, the actuating catheter 610, and the core catheter 615. Referring first to FIG. 14, the housing sheath 605 is extended to cover the forward ends of the actuating catheter 610 and core catheter 615 for intravascular insertion of the implant/delivery system array 600. From this starting position, the housing sheath 605 is retracted in the direction indicated by the arrows 662. In FIG. 15 the housing sheath 605 has been retracted to expose the forward end of the actuating catheter 610 and the collapsed deployment umbrella 642. From this position the actuating catheter 610 is advanced in the direction indicated by the arrows 664. This will cause the deployment umbrellas to expand in the directions indicated by the arrows 666. FIG. 16 shows the expansion of the deployment umbrella 642 produced by distal motion of the actuating catheter 610 relative to the core catheter 615. After the implant 645 has been positioned and adjusted to the proper size, the housing sheath 605 is advanced in the direction indicated by the arrows 668 to collapse and to cover the deployment umbrella 642 for withdrawal of the device from the patient.

[0102] FIGS. 17 and 18 are schematic views illustrating the radial implant support arms 630 and the radial support struts 636 of the implant/delivery system array 600. In FIG.

17, a radial support strut 636 is pivotably attached at its proximal end 638 at a first pivotable joint 670 to the actuation catheter 610. The radial support strut 636 is attached at its distal end 640 to a second pivotable joint 672 at an intermediate point of a corresponding radial implant support arm 630. The radial implant support arm 630 is attached at its distal end 632 by a third pivotable joint 674 to the core catheter 620. FIG. 17 shows the assembly in a closed state. When the actuation catheter 610 is advanced distally over the core catheter 615, as shown by the arrows 676, the radial support strut 636 and the radial implant support arm 630 are extended by the motion at the first pivotable joint 670, the second pivotable joint 672, and the third pivotable joint 674, as shown by the arrow 678. This motion has the effect of expanding the deployment umbrella and folded implant (not shown in FIGS. 17 and 18), allowing it to achieve its greatest radial dimension, prior to engagement and implantation as previously discussed with reference to FIGS. 12-16.

[0103] FIGS. 19 and 20 show further details of the touchdown sensors 648 shown previously in FIG. 12. The touchdown sensor 648 of FIGS. 19 and 20 includes a distal segment 680, an intermediate segment 682, and a proximal segment 684. The distal segment 680 is spring-mounted, so that it is capable of slidable, telescoping displacement over the intermediate segment 682 to achieve a seamless junction with the proximal segment 684 upon maximal displacement. When the touchdown sensor 648 is in its normal condition, the spring extends the proximal segment such that the sensor assumes the orientation shown in FIG. 19. When the implant 645 (FIG. 12) is seated against the periphery of an anatomical opening, the proximal segment 684 of the sensor 648 is compressed against the distal segment 680, as shown in FIG. 20. The distal segment 680 and the proximal segment 684 are both constructed of, are sheathed by, or otherwise covered with a radio-opaque material. However, the intermediate segment 682 is not constructed or coated with such a radio-opaque material. Therefore, when the distal segment 680 is at rest, it is fully extended from the proximal segment 684, and the gap represented by the exposed intermediate segment 682 is visible on radiographic examination. However, when the distal segment 680 is brought to maximum closeness with the proximal segment 684, no such radio-opaque gap is radiographically visible, and the touchdown sensor is said to be "activated". This embodiment allows radiographic monitoring of the position of the touchdown sensor 648 with respect to the degree of extension of the distal catheter segment 680. In the embodiment according to the present invention as shown, one or more touchdown detectors 648 are employed to ascertain that the delivery system for the prosthetic device is located in the proper position to deploy the implant into the mitral annulus. As this anatomic structure cannot be directly identified on fluoroscopy or standard radiographic procedures, such precise location could be otherwise difficult. At the same time, precise localization and engagement of the mitral annulus is critical for proper implant function and safety.

[0104] Touchdown detectors within the embodiments according to the present invention can have a multiplicity of forms, including the telescoping, spring-loaded, radio-opaque elements joined by a non-radio-opaque element as in the aforementioned examples. In embodiments employing magnetic resonance imaging, touchdown detectors according to the present invention may utilize metallic segments

interposed by nonmetallic segments in a similar telescoping, spring-loaded array. Other embodiments include a visually-evident system with telescoping, spring-loaded elements with color-coded or other visual features for procedures in which direct or endoscopic observation would be possible. Still other embodiments of touchdown detectors according to the present invention include touchdown detectors provided with microswitches at their tips, such that momentary contact of sufficient pressure completes an electrical circuit and signals the activation of the touchdown detector to the operator. Still other touchdown detectors according to the present invention are provided with fiberoptic pathways for Rahmen laser spectroscopy or other spectral analytical techniques which are capable of detecting unique tissue qualities of the tissue at the desired site for implantation. In addition, still other embodiments according to the present invention include touchdown detectors containing electrodes or other electronic sensors capable of detecting and signaling the operator when a desired electrophysiologic, impedance, or other measurable quality of the desired tissue is detected for proper implantation. Such electrophysiologic touchdown detectors may include electrical circuits that produce visual, auditory, or other signals to the operator that the detectors are activated and that the implant is in the proper position for attachment.

[0105] In yet other embodiments according to the present invention, other intracardiac or extracardiac imaging techniques including, but not limited to, intravascular ultrasound, nuclear magnetic resonance, virtual anatomic positioning systems, or other imaging techniques may be employed to confirm proper positioning of the implant, obviating the need for the touchdown sensors as previously described.

[0106] FIGS. 21-24 show an implant 700 according to one embodiment of the present invention. In this embodiment, the implant body 705 is bandlike and flexible. Through much of its length, the implant body 705 is provided with a series of retention bars 710 which are oriented to facilitate placement, retention, and removal of the device. The implant body 705 is also provided with an adjustable section 715, which is provided in this example with a series of adjustment stops 720. The adjustment stops 720 may be slots, holes, detents, dimples, ridges, teeth, raised elements, or other mechanical features to allow measured adjustment of the implant 700 in use. In the embodiment shown in FIGS. 21-24, the adjustment stops 720 are engaged by a geared connector 725. FIG. 21 is an end view, showing the implant body 705 curved on itself, with the retention bars 710 to the exterior, and with the adjustable section 715 passing through its engagement with the geared connector 725 and curving internally within the implant body 705 to form a closed, round structure. FIG. 23 shows details of an exemplary geared connector 725, in which a housing 730 is connected to the implant body 705. The housing 730 contains and supports a mechanical worm 740 with an attached first geared head 750 which mates with a second geared head 755. The second geared head 755 is attached to an adjustment stem 760 which is machined to receive a screwdriver-like adjustment element. The various embodiments according to the present invention may require a number of forms of adjustment elements. In the present example, the adjustment element is provided as a finely coiled wire with a distal tip machined to be received by a receiving slot in the adjustment stem 760 (not shown). The relationship between

the distal tip of the adjustment element and the adjustment stem 760 is mechanically similar to a screwdriver bit and screwhead, such that torsion imparted to the adjustment means by the operator will result in the turning of the adjustment stem 760 and second geared head 755 allows motion of the first geared head 750 and worm 740, which creates motion of the adjustable implant section 715 as the worm engages with the series of adjustment tops 725. Excess length of the adjustable section 715 passes through a band slot 735 (FIG. 23), thus allowing the band to move concentrically inside the closed implant body 705. The adjustment element in this embodiment may be designed to remain in place after the deployment umbrella has been retracted and withdrawn. The connection between the adjustment element's distal tip and the adjustment stem 760 may be a simple friction connection, a mechanical key/slot formation, or may be magnetically or electronically maintained.

[0107] As further shown in FIG. 21, the exemplary embodiment employs unidirectional retention bars 710 which are attached to the outer perimeter of the implant body 705. The retention bars 710 are oriented in a consistent, tangential position with respect to the implant body 705 such that rotational motion of the implant body will either engage or release the retention bars 710 upon contact with the desired tissue at the time of deployment. This positioning of the retention bars 710 allows the operator to "screw in" the implant 700 by turning the implant 700 upon its axis, thus engaging the retention bars 710 into the adjacent tissue. As shown in FIG. 24, the retention bars 710 may each be further provided with a terminal hook 775 at the end which would allow for smooth passage through tissue when engaging the retention bars 710 by rotating the implant 700, without permitting the implant 700 to rotate in the opposite direction, because of the action of the terminal hooks 775 grasping the surrounding tissue (much like barbed fish hooks). The terminal hooks 775 thus ensure the seating of the implant 700 into the surrounding tissue.

[0108] FIGS. 25-27 illustrate another embodiment of an implant 800 as contemplated according to the present invention. The implant 800 includes a band 805 (FIG. 27), but the retention bars of the previous example have been eliminated in favor of an outer fabric implant sheath 810. The fabric sheath 810 can be sutured or otherwise affixed to the anatomic tissue in a desired location. The circumference of the implant body 800 is adjusted through a geared connector 825 similar to the geared connector of the bandlike implant array shown in FIG. 23. More specifically, adjustment stops 820 on the band are engaged by a mechanical worm 840 with an attached first geared head 850. The first geared head 850 mates with a second geared head 855. The second geared head 855 is attached to an adjustment stem 860 which is machined to receive a screwdriver-like adjustment element.

[0109] FIG. 28 illustrates an example of the method of use of an implant/delivery system array 600 for positioning an implant 645 in a patient with ischemic annular dilatation and mitral regurgitation. Peripheral arterial access is obtained via conventional cutdown, arterial puncture, or other standard access techniques. After access to the arterial system is attained, guidewire placement is performed and intravascular access to the heart 900 is obtained using fluoroscopic, ultrasound, three-dimension ultrasound, magnetic reso-

nance, or other real-time imaging techniques. The guidewire, deployment device, and implant are passed through the aortic valve in a retrograde fashion into the left ventricle 905 and then into the left atrium 910. At this point, the operator retracts the housing sheath 605, thus unsheathing the collapsed deployment umbrella 642 and implant 645. The deployment umbrella 642 is then distended by the distal motion of the actuation catheter, causing the radial support arms and struts to fully distend. At this point, the touchdown detectors 648 are not in contact with any solid structures, and are fully extended with their radiolucent gaps visible on the imaging system. Once the deployment umbrella is distended, the entire assembly is pulled back against the area of the mitral valve 915. At least two touchdown detectors 648 are employed in a preferred embodiment according to the present invention. When all touchdown detectors show the disappearance of their intermediate, non-opaque, intermediate segments and are thus activated, then the deployment umbrella must be in contact with the solid tissue in the region of the mitral annulus/atrial tissue, and further implant deployment and adjustment may proceed. However, if any one touchdown sensor is not activated, and a radiolucent gap persists, then the device is not properly positioned, and must be repositioned before further deployment. Thus, the touchdown sensor system may assist in the deployment and adjustment of prosthetic devices by the delivery system according to the present invention. Once properly positioned, the operator rotates the actuation catheter in a prescribed clockwise or counterclockwise manner to engage the retention bars on the implant into the tissue in the region of the mitral annulus/atrial tissue. Should re-positioning be required, a reverse motion would disengage the retention bars from the annular/atrial tissue, and repositioning may be performed, again using the touchdown detectors for proper placement. Once firmly seated, the adjustment element(s) are operated to achieve the desired degree of annular reduction. Real-time trans esophageal echocardiography, intravascular echocardiography, intracardiac echocardiography, or other modalities for assessing mitral function may then be employed to assess the physiologic effect of the repair on mitral function, and additional adjustments may be performed. Once a desired result has been achieved, the release elements are activated to detach the implant from the deployment umbrella. The operator then retracts the actuation catheter and extends the housing sheath, collapsing the deployment umbrella and covering the components for a smooth and atraumatic withdrawal of the device from the heart and vascular system.

[0110] If desired, the adjustment elements may be left in position after the catheter components are withdrawn for further physiologic adjustment. In yet other embodiments according to the present invention, a catheter-based adjustment elements may subsequently be re-inserted through a percutaneous or other route. Such an adjustment element may be steerably operable by the operator, and may be provided with magnetic, electronic, electromagnetic, or laser-guided systems to allow docking of the adjustment element with the adjustable mechanism contained within the implant. In still other embodiments, the adjustment mechanism may be driven by implanted electromechanical motors or other systems, which may be remotely controlled by electronic flux or other remote transcutaneous or percutaneous methods.

[0111] In the case of pulmonic valve repair, initial catheter access is achieved through a peripheral or central vein. Access to the pulmonary valve is also achieved from below the valve once central venous access is achieved by traversing the right atrium, the tricuspid valve, the right ventricle, and subsequently reaching the pulmonic valve.

[0112] In yet other embodiments according to the present invention, catheter access to the left atrium can be achieved from cannulation of central or peripheral veins, thereby achieving access to the right atrium. Then a standard atrial trans-septal approach may be utilized to access the left atrium by creation of an iatrogenic atrial septal defect (ASD). In such a situation, the mitral valve may be accessed from above the valve, as opposed to the retrograde access described in Example 1. The implant and a reversed deployment umbrella may be utilized with implant placement in the atrial aspect of the mitral annulus, with the same repair technique described previously. The iatrogenic ASD may then be closed using standard device methods. Access to the aortic valve may also be achieved from above the aortic valve via arterial access in a similar retrograde fashion.

[0113] Other embodiments of the adjustable implant and methods according to the present invention include gastrointestinal disorders such as gastro-esophageal reflux disease (GERD), a condition in which the gastro-esophageal (GE) junction lacks adequate sphincter tone to prevent the reflux of stomach contents into the esophagus, causing classic heartburn or acid reflux. This not only results in discomfort, but may cause trauma to the lower esophagus over time that may lead to the development of pre-cancerous lesions (Barrett's esophagus) or adenocarcinoma of the esophagus at the GE junction. Surgical repair of the GE junction has historically been achieved with the Nissen Fundoplication, an operative procedure with generally good results. However, the Nissen procedure requires general anesthesia and a hospital stay. Utilizing the devices and methods according to the present invention, an adjustable implant would obviate the need for a hospital stay and be performed in a clinic or gastroenterologist's office. Referring now to FIGS. 29 and 30, an umbrella deployment device 600 with implant 645 is passed under guidance of an endoscope 1000, through the patient's mouth, esophagus 1005, and into the stomach 1010, where the deployment device 600 is opened with expansion of the implant 645 and touchdown detectors 648 with a color-coded or otherwise visible gap. The touchdown detectors are then engaged onto the stomach around the gastroesophageal junction 1015 under direct endoscopic control until all touchdown detectors 648 are visually activated. The implant is then attached to the stomach wall, 1020 the umbrella 642 is released and withdrawn, leaving behind the implant 645 and the adjustment elements. The implant is then adjusted until the desired effect is achieved, i.e., minimal acid reflux either by patient symptoms, pH monitoring of the esophagus, imaging studies, or other diagnostic means. If the patient should suffer from gas bloat, a common complication of gastroesophageal junction repair in which the repair is too tight and the patient is unable to belch, the implant can be loosened until a more desirable effect is achieved.

[0114] In various embodiments anticipated by the present invention, the implant body may be straight, curved, circular, ovoid, polygonal, or some combination thereof. In various embodiments anticipated by the present invention

the implant may be capable of providing a uniform or non-uniform adjustment of an orifice or lumen within the body. The implant body may further completely enclose the native recipient anatomic site, or it may be provided in an interrupted form that encloses only a portion of the native recipient anatomic site. In still other embodiments of the present invention, the implant body may be a solid structure, while in yet other embodiments the implant body may form a tubular or otherwise hollow structure. In one embodiment of the present invention, the body may further be a structure with an outer member, an inner member, and optional attachment members. In such an embodiment, the outer member of the implant body may serve as a covering for the implant, and is designed to facilitate and promote tissue ingrowth and biologic integration to the native recipient anatomic site. The outer member in such an embodiment may be fabricated of a biologically compatible material, such as Dacron, PTFE, malleable metals, other biologically compatible materials or a combination of such biologically compatible materials in a molded, woven, or non-woven configuration. The outer member in such an embodiment also serves to house the inner member. In this embodiment, the inner member provides an adjustment means that, when operated by an adjustment mechanism, is capable of altering the shape and/or size of the outer member in a defined manner.

[0115] In alternate embodiments according to the present invention, the adjustment means may be located external to or incorporated within the outer member. In yet additional alternate embodiments contemplated by the present invention, the implant body may consist of an adjustment means without a separate outer member covering said adjustment means.

[0116] In various embodiments according to the present invention, the adjustment means may include a mechanism which may be threaded or non-threaded, and which may be engaged by the action of a screw or worm screw, a friction mechanism, a friction-detent mechanism, a toothed mechanism, a ratchet mechanism, a rack and pinion mechanism, or such other devices to permit discreet adjustment and retention of desired size a desired position, once the proper size is determined.

[0117] In yet other embodiments according to the present invention, the adjustment means may comprise a snare or purse string-like mechanism in which a suture, a band, a wire or other fiber structure, braided or non-braided, monofilament or multifilament, is capable of affecting the anatomic and/or physiologic effects of the implant device on a native anatomic recipient site upon varying tension or motion imparted to said wire or fiber structure by a surgeon or other operator. Such an adjustment means may be provided as a circular or non-circular structure in various embodiments. Changes in tension or motion may change the size and/or shape of the implant.

[0118] In various embodiments according to the present invention, the adjustment means may be a metallic, plastic, synthetic, natural, biologic, or any other biologically-compatible material, or combination thereof. Such adjustment means may further be fabricated by extrusion or other molding techniques, machined, or woven. Furthermore, in various embodiments of the present invention, the adjustment means may be smooth or may include slots, beads, ridges, or any other smooth or textured surface.

[0119] In various embodiments of the present invention, the implant body may be provided with one or more attachment members such as grommets or openings or other attachment members to facilitate attachment of the implant to the native recipient site. In alternate embodiments, the implant body may attach to or incorporate a mechanical tissue interface system that allows a sutureless mechanical means of securing the implant at the native recipient site. In still other alternate embodiments, sutures or other attachment means may be secured around or through the implant body to affix the implant body to the native recipient site. In yet other embodiments of the present invention, mechanical means of securing the implant body to the native recipient site may be augmented or replaced by use of fibrin or other biologically-compatible tissue glues or similar adhesives.

[0120] In additional various embodiments according to the present invention, the adjustable implant may be employed to adjustably enlarge or maintain the circumference or other dimensions of an orifice, ostium, lumen, or anastomosis in which a disease process tends to narrow or constrict such circumference or other dimensions.

[0121] In various embodiments according to the present invention, an adjustment mechanism may be provided to interact with the adjustment means to achieve the desired alteration in the size and/or position of the adjustment means. Such an adjustment mechanism may include one or more screws, worm-screw arrays, rollers, gears, frictional stops, a friction-detent system, ratchets, rack and pinion arrays, micro-electromechanical systems, other mechanical or electromechanical devices or some combination thereof.

[0122] In some embodiments as contemplated by the present invention, an adjustment tool may be removably or permanently attached to the adjustment mechanism and disposed to impart motion to the adjustment mechanism and, in turn, to the adjustment means to increase or decrease the anatomic effect of the implant on the native recipient site.

[0123] In alternate embodiments according to the present invention, micromotor arrays with one or more micro-electromechanical motor systems with related electronic control circuitry may be provided as an adjustment means, and may be activated by remote control through signals conveyed by electromagnetic radiation or by direct circuitry through electronic conduit leads which may be either permanently or removably attached to said micromotor arrays.

[0124] In still other various embodiments according to the present invention, the adjustment mechanism may be provided with a locking mechanism disposed to maintain the position of the adjustment means in a selected position upon achievement of the optimally desired anatomic and/or physiologic effect upon the native recipient site and the bodily organ to which it belongs. In other embodiments, no special locking mechanism may be necessary due to the nature of the adjustment means employed.

[0125] In yet other alternate embodiments according to the present invention, the adjustment means and/or the outer member structure may be a pliable synthetic material capable of rigidification upon exposure to electromagnetic radiation of selected wavelength, such as ultraviolet light. In such embodiments, exposure to the desired electromagnetic radiation may be achieved by external delivery of such radiation to the implant by the surgeon, or by internal

delivery of such radiation within an outer implant member using fiberoptic carriers placed within said outer member and connected to an appropriate external radiation source. Such fiberoptic carriers may be disposed for their removal in whole or in part from the outer implant member after suitable radiation exposure and hardening of said adjustment means.

[0126] The present invention also provides methods of using an adjustable implant device to selectively alter the anatomic structure and/or physiologic effects of tissues forming a passageway for blood, other bodily fluids, nutrient fluids, semi-solids, or solids, or wastes within a mammalian body. Various embodiments for such uses of adjustable implants include, but are not limited to, open surgical placement of said adjustable implants at the native recipient site through an open surgical incision, percutaneous or intravascular placement of said implants under visual control employing fluoroscopic, ultrasound, magnetic resonance imaging, or other imaging technologies, placement of said implants through tissue structural walls, such as the coronary sinus or esophageal walls, or methods employing some combination of the above techniques. In various embodiments as contemplated by the present invention, adjustable implants may be placed and affixed in position in a native recipient anatomic site by trans-atrial, trans-ventricular, trans-arterial, trans-venous (i.e., via the pulmonary veins) or other routes during beating or non-beating cardiac surgical procedures or endoscopically or percutaneously in gastrointestinal surgery.

[0127] Furthermore, alternate methods for use of an adjustable implant device may provide for the periodic, post-implantation adjustment of the size of the anatomic structure receiving said implant device as needed to accommodate growth of the native recipient site in a juvenile patient or other changes in the physiologic needs of the recipient patient.

[0128] Adjustment of the adjustable implants and the methods for their use as disclosed herein contemplates the use by the surgeon or operator of diagnostic tools to provide an assessment of the nature of adjustment needed to achieve a desired effect. Such diagnostic tools include, but are not limited to, transesophageal echocardiography, echocardiography, diagnostic ultrasound, intravascular ultrasound, virtual anatomic positioning systems integrated with magnetic resonance, computerized tomographic, or other imaging technologies, endoscopy, mediastinoscopy, laparoscopy, thoracoscopy, radiography, fluoroscopy, magnetic resonance imaging, computerized tomographic imaging, intravascular flow sensors, thermal sensors or imaging, remote chemical or spectral analysis, or other imaging or quantitative or qualitative analytic systems.

[0129] In one aspect, the implant/delivery system of the present invention comprises a collapsible, compressible, or distensible prosthetic implant and a delivery interface for such a prosthetic implant that is capable of delivering the prosthetic implant to a desired anatomic recipient site in a collapsed, compressed, or non-distended state, and then allowing controlled expansion or distension and physical attachment of such a prosthetic implant by a user at the desired anatomic recipient site. Such a system permits the delivery system and prosthetic implant to be introduced percutaneously through a trocar, sheath, via Seldinger tech-

nique, needle, or endoscopically through a natural bodily orifice, body cavity, or region and maneuvered by the surgeon or operator to the desired anatomic recipient site, where the delivery system and prosthetic implant may be operably expanded for deployment. When desirable, the implant/delivery system according to the present invention is also capable of allowing the user to further adjust the size or shape of the prosthetic implant once it has been attached to the desired anatomic recipient site. The delivery system according to the present invention is then capable of detaching from its interface with the prosthetic implant and being removed from the anatomic site by the operator. The delivery system and prosthetic implant may be provided in a shape and size determined by the anatomic needs of an intended native recipient anatomic site within a mammalian patient. Such a native recipient anatomic site may be a heart valve, the esophagus near the gastro-esophageal junction, the anus, or other anatomic sites within a mammalian body that are creating dysfunction that might be relieved by an implant capable of changing the size and shape of that site and maintaining a desired size and shape after surgery.

[0130] In various embodiments contemplated by the present invention, the delivery system may be a catheter, wire, filament, rod, tube, endoscope, or other mechanism capable of reaching the desired recipient anatomic site through an incision, puncture, trocar, or through an anatomic passageway such as a vessel, orifice, or organ lumen, or trans-abdominally or trans-thoracically. In various embodiments according to the present invention, the delivery system may be steerable by the operator. The delivery system may further have a delivery interface that would retain and convey a prosthetic implant to the desired recipient anatomic site. Such a delivery interface may be operably capable of distending, reshaping, or allowing the independent distension or expansion of such a prosthetic implant at the desired recipient anatomic site. Furthermore, such a delivery interface may provide an operable means to adjust the distended or expanded size, shape, or physiologic effect of the prosthetic implant once said implant has been attached in situ at the desired recipient anatomic site. In various embodiments according to the present invention, such adjustment may be carried out during the procedure in which the implant is placed, or at a subsequent time. Depending upon the specific anatomic needs of a specific application, the delivery interface and the associated prosthetic implant may be straight, curved, circular, helical, tubular, ovoid, polygonal, or some combination thereof. In still other embodiments of the present invention, the prosthetic implant may be a solid structure, while in yet other embodiments the prosthetic implant may form a tubular, composite, or otherwise hollow structure. In one embodiment of the present invention, the prosthetic implant may further be a structure with an outer member, an inner member, and optional attachment members. In such an embodiment, the outer member of the prosthetic implant may serve as a covering for the implant, and is designed to facilitate and promote tissue ingrowth and biologic integration to the native recipient anatomic site. The outer member in such an embodiment may be fabricated of a biologically compatible material, such as Dacron, PTFE, malleable metals, other biologically compatible materials or a combination of such biologically compatible materials in a molded, woven, or non-woven configuration. The outer member in such an embodiment also serves to house the inner member. In this embodiment, the inner member pro-

vides an adjustment means that, when operated by an adjustment mechanism, is capable of altering the shape and/or size of the outer member in a defined manner.

[0131] In some embodiments according to the present invention, at least some portions of the adjustable inner or outer member may be elastic to provide an element of variable, artificial muscle tone to a valve, sphincter, orifice, or lumen in settings where such variability would be functionally valuable, such as in the treatment of rectal incontinence or vaginal prolapse.

[0132] In various embodiments according to the present invention, the delivery interface would have an attachment means to retain and convey the prosthetic implant en route to the native anatomic recipient site and during any in situ adjustment of the prosthetic implant once it has been placed by the operator. Such an attachment means would be operably reversible to allow detachment of the prosthetic implant from the delivery interface once desired placement and adjustment of the prosthetic implant has been accomplished.

[0133] In one embodiment of the present invention, illustrated in FIG. 31, an implantable device system 1000 for controlling at least the size or shape of an anatomical structure or lumen includes an implantable device 1002 and an adjustment tool 1006. The anatomical structure or lumen is an anatomic site with dysfunction that can be relieved by the implantable device 1002 to change a size or shape of the anatomic site.

[0134] The implantable device 1002, in one exemplary embodiment, has a diameter no larger than 3.5 mm. In another embodiment the implantable device 1002 is configured to have variable size relative to its placement at an annulus of a heart valve. The implantable device 1002 has an adjustable member 1004 configured to adjust the dimensions of the implantable device 1002. In one embodiment, the torqueable adjustment tool 1006 provides adjustment of the dimensions of the implantable device 1002. The adjustable member 1004, in some embodiments, may be oriented to receive the adjustment tool from a direction generally perpendicular to the primary plane defined by the implant device 1002. Such an orientation is advantageous for intravenous access of the tool and in situ adjustment of the implant device 1002. The implantable device 1002 can have a configuration where there are different pulling rates at different sections of the implantable device 1002. The implantable device 1002 may optionally include a flexible tube (1032, FIG. 38) and an outer fabric sheath (810, FIGS. 25 and 26), which are not shown in the subsequent figures for clarity. The outer fabric sheath can be sutured, stapled, clipped, coiled, or otherwise affixed to anatomic tissue in a desired location. Generally the desired location is considered to be the internal surface of the area to be controlled, such as (for example) an interior wall of an organ, artery, or other internal anatomic passage. Also, while the implantable device 1002 is generally shown in the subsequent figures to have a "D"-shaped configuration, it should be understood that other shapes can be used in accordance with embodiments of the present invention.

[0135] Still referring to FIG. 31, in certain embodiments, the adjustment tool 1006 is at least partially hollow, and in one specific embodiment at least 50% hollow. The adjustment tool 1006 may be an elongated tool, which has a proximal end and a distal end releasably attached to the

adjustable member **1004** of implantable device **1002**. The adjustment tool **1006** may extend from its distal end coupled to the adjustable member **1004** to a control interface (e.g., handle) at the proximal end located preferably outside of the patient's body. The adjustment tool **1006**, when coupled to the adjustable member **1004** of implantable device **1002**, can provide a preferential shape change of the implantable device **1002** in planar and non-planar directions. The adjustment tool **1006** can adjust the implantable device **1002** in terms of narrowing or widening the dimensions of the implantable device **1002**.

[0136] FIG. 32A is a schematic of the implant device **1002** without showing an optional flexible outer tube and fabric sheath. The implantable device includes an adjustable member **1004** and adjustable tube portions **1013a** and **1013b**, which slide within hollow tube portions **1014a** and **1014b**, and retaining tube **1015**. FIG. 32B is a schematic of a disassembled portion of implantable device **1002** with retaining tube **1015** removed. As shown in FIG. 32B, in various embodiments, the implantable device **1002** includes a threaded rod **1008** threaded with right-hand helical grooves **1010** and left-hand helical grooves **1012**. Other embodiments may include a threaded rod **1008** with helical grooves in a single direction (e.g., all right-hand grooves or all left-hand grooves). Threaded rod **1008** may be a rigid material such as titanium, stainless steel, or a polymer. Adjustable tube portions **1013a** and **1013b** enclose at least a portion of grooves **1010** and **1012** so that pins **1016a**, **1016b** or protuberances on the inside diameter of the adjustable tube portions **1013a**, **1013b** are engaged by the grooves **1010** and **1012**, respectively. In other embodiments, pins **1016a**, **1016b** may be replaced by threads along the inside diameter of the adjustable tube portions **1013a**, **1013b**. Helical grooves **1010** and **1012** may be single channels or multiple channels to engage single pins **1016a**, **1016b** or multiple pins. Hollow tube portions **1014a**, **1014b** are relatively rigid to maintain curvature of the adjustable tube portions **1013a**, **1013b** regardless of the adjustment position.

[0137] The implantable device **1002** can have a coating including, but not limited to, heparin, and antibiotic, collagen, and an agent that promotes tissue in growth, PGLA, a de-calcification agent and the like. The implantable device **1002** can be made of a variety of materials including, but not limited to, a shape memory alloy (SMA), a shape memory polymer (SMP), titanium, stainless steel, polymer, a suture-based material, a biological material and the like.

[0138] In another embodiment of the present invention, illustrated in FIGS. 33 through 37, the adjustable member **1004** provides translated motion through rotation. FIGS. 33 through 35 illustrate a theory of operation of an embodiment of the present invention, while FIGS. 36 and 37 shown details of the adjustment member **1004**.

[0139] Referring to now FIG. 33, adjustable member **1004** of implantable device **1102** is shown including a docking port **1021** to receive the distal tip of the adjustment tool **1006** (FIG. 31). In this embodiment, implant device includes a set of inner tubing **1028a**, **1028b** and a set of outer tubing **1026a**, **1026b** that can move relative to each other. The ends of the inner tubing **1028a**, **1028b** that do not engage the outer tubing **1026a**, **1026b** are secured to a set of hollow tubing **1014a**, **1014b** so that the inner tubing **1028a**, **1028b** does not move relative to the hollow tubing **1014a**, **1014b**. Although

hollow tube portions **1014a**, **1014b** may be separate pieces that are permanently abutted when assembled, in some embodiments, the hollow tube portions **1014a**, **1014b** may be formed from a single tubing piece. An inner cable **1030** passes through the various tubing. Thus, the rigidity of the hollow tubing can be used to maintain the adjustable implant **1102** shape in certain dimensions so that adjustment of the device can be restricted to a preferred dimension, for example, an anterior-posterior dimension.

[0140] As shown in more detail in FIGS. 36 and 37, adjustable member **1004** may also include a pinion gear **1022** (which may be integral to a docking port **1021**) and a crown gear **1024**. FIG. 36 provides an isometric view of the adjustable member **1004**, and FIG. 37 provides a cut-away view of the adjustable member **1004**. As can be seen in the figures, the pinion gear **1022** engages the crown gear **1024**. In some embodiments, the pinion gear **1022** may be eliminated from adjustable member **1004**, and the distal tip of the adjustment tool **1006** may serve as the pinion gear when the tool is coupled to the docking port **1021**. When coupled to the docking port **1021**, the adjustment tool **1006** can rotate the pinion gear **1022**.

[0141] Referring back to FIG. 33, the implantable device **1102** is shown generally at the middle of its adjustment range. Outer tubing **1026a**, **1026b** is affixed to the adjustable member **1004** and extends along a portion of the circumference of implantable device **1102**. Inner tubing **1028a**, **1028b** is affixed to hollow tubing **1014a**, **1014b**, respectively. Similar to the single threaded rod **1008** of FIG. 32B, threaded rods **1018a**, **1018b** sit inside the hollow tubing **1014a**, **1014b** and are threadedly engaged therewith. Threaded rods **1018a**, **1018b** may be a rigid material such as titanium, stainless steel, or a polymer. Hollow tube portions **1014a**, **1014b** enclose the threaded rods **1018a**, **1018b** such that rotation of the threaded rods **1018a**, **1018b** causes them to move axially within the hollow tube portions **1014a**, **1014b**. The threaded rod **1018a** may have right-handed threads, and the threaded rod **1018b** may have left handed threads. Other embodiments may include threaded rods **1018a**, **1018b** with threads in a single direction (e.g., all right-hand grooves or all left-hand threads).

[0142] The crown gear **1024**, and one end of each threaded rod **1018a**, **1018b** are all attached to an inner cable **1030**. Inner cable **1030** may be a cable or tube of any material with sufficient flexibility to conform to a shape of the implantable device **1102** while translating torque. For example, suitable material for inner cable **1030** may include titanium or stainless steel. As shown more clearly in FIGS. 36 and 37, the rotation of crown gear **1024** imparts rotation to cable **1030** in the same direction.

[0143] Referring to FIG. 34, when the handle of adjustment tool **1006** (not shown in this figure) is rotated clockwise in docking port **1021**, it causes clockwise rotation of the pinion gear **1022** (in FIG. 36). Rotation of the pinion gear **1022** in turn rotates crown gear **1024**. The rotation of crown gear **1024** causes rotation of inner cable **1030**, which imparts rotational movement to each threaded rod **1018a**, **1018b**. The rotation applied to the threaded rods **1018a**, **1018b** causes them to advance into their respective hollow tubing **1014a**, **1014b** in the directions A_1 , A_2 shown. As shown in FIG. 34, when threaded rods **1018a**, **1018b** advance toward the middle of the hollow tubing **1014a**,

1014b the overall circumference of the implant device **1002** is reduced. Advancing the threaded rods **1018a**, **1018b** drives the inner cable **1030** into the hollow tubing **1014a**, **1014b**. Translation of inner cable **1030** into the hollow tubing **1014a**, **1014b** causes the hollow tubing **1014a**, **1014b** to move towards adjustable member **1004** in the direction B_1 shown. Inner tubing **1028a**, **1028b** slides into outer tubing **1026a**, **1026b** to accommodate movement of the inner cable **1030**.

[0144] Referring to FIG. 35, the handle of adjustment tool **1006** (not shown in this figure) is rotated counter-clockwise in docking port **1021** to cause counter-clockwise rotation of the pinion gear **1022** (FIG. 36). Rotation of the pinion gear **1022**, in turn rotates crown gear **1024**. The rotation of crown gear **1024** causes rotation of inner cable **1030**, which imparts rotational movement to each threaded rod **1018a**, **1018b**. The rotation applied to the threaded rods **1018a**, **1018b** causes them to begin to withdraw from their respective hollow tubing **1014a**, **1014b** in the directions A_2 , A_1 shown. As shown in FIG. 35, as threaded rods **1018a**, **1018b** withdraw from the middle of the hollow tubing **1014a**, **1014b** the overall circumference of the implant device **1002** is increased. Withdrawal of the threaded rods **1018a**, **1018b** pushes the inner cable **1030** out of the hollow tubing **1014a**, **1014b**. Translation of inner cable **1030** out of the hollow tubing **1014a**, **1014b** causes the hollow tubing **1014a**, **1014b** to move away from adjustable member **1004** in the direction B_2 shown. Inner tubing **1028a**, **1028b** telescopes out of outer tubing **1026a**, **1026b** to accommodate movement of the inner cable **1030**.

[0145] The inner tubing **1028a**, **1028b**, the outer tubing **1026a**, **1026b**, and the hollow tubing **1014a**, **1014b** may be covered by a flexible tube **1032**, such as a silicone tube, shown in FIG. 38. In one embodiment, outer flexible tube **1032** is provided with no seam in the axial direction of the tube to allow for better tissue ingrowth after the implant procedure. In other embodiments inner tubing **1028a**, **1028b** may be eliminated, as shown in FIG. 39.

[0146] FIG. 39 provides an assembled cross-section view of an implantable device **1202** according to an embodiment of the invention. The implant device includes the adjustable member **1004**, the outer tubing **1026a**, **1026b**, the hollow tubing **1014a**, **1014b**, the inner cable **1030**, and the threaded rods **1018a**, **1018b** as discussed in relation to FIGS. 33-35. As shown in FIG. 39, hollow tubing **1014a**, **1014b** may extend further along the length of inner cable **1030** than shown in other embodiments of FIGS. 33-35 to better maintain a preferred shape of the implant. Hollow tubing **1014a**, **1014b** may be threaded to receive the threaded rods **1018a**, **1018b**; or hollow tubing may optionally include a threaded insert (spar **1019a**, **1019b**) affixed to the inner diameter of hollow tubing **1014a**, **1014b**. In operation, as previously described, an adjustment tool may impart motion to the adjustable member **1004**. Gears in the adjustable member translate motion to the inner cable **1030** that, in turn translate motion to the attached threaded rods **1018a**, **1018b**. Depending on the direction of rotation, rotation of threaded rods **1018a**, **1018b** causes the threaded rods **1018a**, **1018b** to be drawn toward or away from the middle of the hollow tubing **1014a**, **1014b**, thus reducing or increasing the overall circumference of the implant device **1002**. The flexible outer tube **1032** and a seal jacket **1100** (also shown in FIG. 40) encapsulate the device so that no moving parts are exposed.

The flexible outer tube **1032** provide sufficient rigidity to maintain a generally planar dimension, while allowing the device to adjust shape generally in a preferred dimension, such as the anterior-posterior dimension. As shown in FIG. 39, the flexible outer tube **1032** may be further covered by an outer fabric sheath **1110** or thin sewing cuff. Elimination of the inner tubing (**1028a**, **1028b** of FIG. 35) eliminates the need for telescoping parts and prevents the possibility of telescoping tubes being sutured or clipped together during attachment of the implant.

[0147] Referring to FIG. 40, the adjustable member **1004** can include a seal jacket **1100**. FIG. 40 shows an embodiment of the seal jacket **1100**. The seal jacket **1100** may include a cover **1102** for the docking port **1021** (FIG. 33) of the adjustable member **1004**. The cover **1102** may be in the form of a slit septum, flaps, elastic material or the like. The seal jacket cover **1102** may be included as part of a seal jacket **1100** that covers the entire housing of the adjustable member **1004** or a separate piece. In one embodiment, the seal jacket **1100** may be secured to the flexible tube **1032**. The seal jacket **1100** and flexible tube **1032** may be secured by an adhesive bond, a wrap, sutures, or the like. The cover **1102** provides access for an adjustment tool to couple to the docking port, while reducing the possibility of thrombus. In some embodiments, seal jacket cover **1102** and/or the seal jacket **1100** may be made of silicone, and covered by a polyester sewing layer or fabric sheath (e.g., **1110** of FIG. 39). In various embodiments, the seal jacket fits over the housing of the adjustable member **1004** that includes a crown gear coupled to a cable, can provide pinion access, and the like. In operation, the distal tip of an adjustment tool passes through the cover **1102** to engage the rotatable gear of adjustable member **1004**.

[0148] FIG. 41 shows an embodiment of implantable device **1302** including a first adjustment band **1042a** and a second adjustment band **1042b**. The first and second adjustment bands **1042a**, **1042b** can be overlapped, and the amount of overlap is effected by how the implantable device **1302** is sized. The first and second bands **1042a**, **1042b** can be slidable relative to each other. An adjustable member **1304** is coupled to the first band **1042a** and the second band **1042b**, and pulls or pushes them toward or away from each other. The first band **1042a** and the second band **1042b** can have flexible portions **1046a**, **1046b** configured to create a flexible zone at the primary bend regions **1047a**, **1047b**. The flexible portions **1046a**, **1046b** can have varying lengths and may also include one or more rigid portions **1044**. These rigid portions **1044** can include welded braids or bands, or have a higher durometer material than the flexible portions **1046a**, **1046b**. The flexible portions **1046a**, **1046b** and rigid portions **1044** may be part of the same material as the first and second bands **1042a**, **1042b**, or one or more portions may be separate material that is joined to form continuous piece.

[0149] The first and second bands **1042a**, **1042b** can have different sizes or the same sizes. In one specific embodiment, the first and second bands **1042a**, **1042b** are about 0.5 to 3 mm in thickness and about 5 to 10 mm in width. The first and second bands **1042a**, **1042b** can be made of a variety of materials including, but not limited to, an SMA, an SMP, titanium, stainless steel, polymer, a suture-based material, a biological material and the like. In one embodiment, the first and second bands **1042a**, **1042b** include a plurality of band

layers. At least a portion of the first and second bands **1042a**, **1042b** may have superelastic properties. Implant **1302** may include a flexible, extruded outer layer (not shown) or hollow tube, such as flexible tube **1032** of FIG. **38**, to encase the structure formed by the first and second bands **1042a**, **1042b** flexible portions **1046a**, **1046b**, and rigid portions **1044**. The parts of the first and second bands **1042a**, **1042b**, that extend past adjustable member **1304** can be contained within the hollow interior of the outer layer.

[**0150**] FIG. **42** provides a more detailed schematic view of the unassembled adjustment bands and adjustment member of FIG. **41**. The first and second bands **1042a**, **1042b** may include a series of adjustment stops **1048**. Adjustment stops may be in the form of holes, detents, dimples, ridges, teeth, raised elements, other mechanical features or the like. These holes **1048** on each of the bands **1042a**, **1042b** are coupled to an adjustable member **1304**. The adjustable member **1304** may be generally cylindrical (such as a spool) with a series of teeth **1050** or protrusions radially positioned to engage the adjustment stops **1048**. Adjustable member **1304** may also include a docking port **1320** to receive an adjustment tool to trigger rotational movement of the adjustable member.

[**0151**] FIG. **43** provides an assembled view of the adjustment band and adjustment member of FIG. **42**. When mounted in a housing (not shown in FIG. **43**), the adjustable member **1304** may be mounted on an axis to allow for rotational movement. The first and second bands **1042a**, **1042b** pass on either side of adjustable member **1304** so that the teeth **1050** engage the adjustment stops **1048** in each of the bands **1042a**, **1042b**. Rotating the adjustable member in turn tightens or loosens the bands.

[**0152**] FIG. **44** is a cut-away view of an embodiment of the gearbox for the adjustment band of FIG. **41**. In this embodiment, the adjustable member **1304** rests on a spring **1052** inside a housing **1040** for the adjustable member. The housing **1040** includes access and guidance for the first and second bands (**1042a**, **1042b** of FIG. **43**) to couple with the teeth **1050** of the adjustable member **1304**. The spring **1052** forces the adjustable member **1304** upward so that teeth **1056** on the top of the adjustable member **1304** engage with teeth **1058** on the inside upper surface of the housing **1040**. Engagement of the adjustable member teeth **1056** with the housing teeth **1058** locks the adjustable member **1304** in place to prevent rotational movement. Downward force, applied for example by an adjustment tool, against the spring **1052** disengages the teeth **1056** and **1058** so that the adjustable member **1304** can be rotated to adjust the size or shape of implantable device **1302**.

[**0153**] In another embodiment, FIG. **45** provides a schematic view of an implantable device **1402** of the present invention with a plurality of sliding bands that can be opened and closed to effect a shape change. As with the previous embodiments of FIGS. **41-44**, the first and second bands **1042a**, **1042b** pass on either side of adjustable member **1304** so that the teeth **1050** engage the adjustment stops **1048** in each of the bands **1042a**, **1042b**. Additional bands **1042c** may be incorporated to increase stiffness at different areas of the implant device **1402** to provide preferential shape change. The additional bands **1042c** may be secured to the first and second bands **1042a**, **1042b** using welds **1043**, adhesive or other mechanical techniques known in the art.

[**0154**] As illustrated in FIG. **46**, in one embodiment, an implantable device **1502** has an anterior portion **1060**, a posterior portion **1062** and dual threads that provide preferential adjustment of one side or the other of implantable device **1002**. The implantable device **1502** has two independently adjustable threaded portions **1064a**, **1064b** used to achieve different pulling rates and/or lateral dimensions. The adjustable threaded portions **1064a**, **1064b** can be connected to one or more adjustable member **1004** of the implantable device **1502** and positioned at either the posterior or anterior portions of the implantable device **1502**. In one embodiment, the posterior portion **1062** may be a rigid member which includes threaded hex screws **1066a**, **1066b**, internal threads or similar structures. In one embodiment, the hex screws **1066a**, **1066b** are attached in a manner that allows rotation of the hex screws so that the threads may engage adjustable threaded portions **1064a**, **1064b**. Rigid posterior portion **1062** may include one or more of adjustable members **1004** that can receive a tool to impart rotational motion through an inner tube or cable to one or more of hex screws **1066a**, **1066b**, as described above. Anterior portion **1060** may be a flexible tube to accommodate shape change as the anterior and posterior portions **1060**, **1062** move relative to each other.

[**0155**] In another embodiment, differently pitched threads or other mechanisms may be used to provide non-symmetrical shape change of the implant device. For example, referring to FIG. **46**, wider threads on threaded portion **1064b**, in relation to the threads of threaded portion **1064a**, would allow an adjustable member **1004** to expand or contract the implant **1502** more rapidly on the side of threaded portion **1064b** to provide preferential shape change for a selected region while using a single adjustable member.

[**0156**] FIG. **47** is a schematic view of an embodiment of an adjustable member **1604** for an implantable device. An adjustment tool may impart reciprocating motion to the adjustable member **1604** that includes a clover gear **1070** mounted in a housing **1072**. The inner cable **1030** (FIG. **33**) of the implantable device, for example, is affixed to the clover gear **1070** such that rotation of the clover gear transmits torque through the inner cable **1030** to a screw or other adjustable portion of the implantable device as previously disclosed. In this embodiment, the adjustment tool can provide reciprocating action to provide for adjustment. The adjustable member takes an axial force applied to the control portion at the proximal end of the adjustment tool and converts it to a rotational force applied to the inner cable **1030** of the implantable device. Reciprocating axial force may be provided from an adjustment tool by using spring-mounted buttons pressed by the user. Pressing a first button may transmit a downward axial motion to a first ribbon **1074** which engages the clover gear **1070** to cause clockwise rotation of the clover gear **1070**. A spring or other return force pushes the first ribbon back to its original position after each click or press of the button. Similarly, pressing a second button may transmit a downward axial motion to a second ribbon **1076** that engages the clover gear **1070** to cause counter-clockwise rotation of the clover gear **1070**.

[**0157**] In another embodiment, the adjustment tool provides coarse adjustment and fine adjustment. This varied adjustment can be achieved with the adjustment tool having screws with different threads.

[0158] FIG. 48 provides a schematic view of an embodiment of the implantable device system 1000 including an adjustment tool 1706 with high column strength and stiffness. The adjustment tool 1706 has a shaft 1794 and a handle 1096 with sufficient column strength to ensure a downward axial force on the handle 1096 provides proper engagement with the adjustable member 1004 of the implantable device 1002. The handle 1096 may be a grip-like handle, as shown, or a smaller pen-type handle. The adjustment tool 1706 can include mechanical locking at the distal region 1782 to lock with the adjustable member 1004. The mechanical locking is configured to provide engagement and disengagement tactile feel to the physician.

[0159] FIG. 49 is a schematic view of another embodiment of the implantable device system 1000 including an adjustment tool 1806 with reduced column stiffness. The adjustment tool 1806 has a handle 1096 a shaft 1080 with reduced column stiffness for greater flexibility and easier articulation of the adjustment tool 1806. The handle 1096 may be a grip-like handle, as shown, or a smaller pen-type handle. The easier articulation offered by the this embodiment may facilitate user positioning of the device in vivo and clearing adjacent biological structures, particularly when it is docked to the adjustable member 1004 of the implant 1002. Flexibility may be varied along the length of the adjustment tool shaft 1080. Flexibility may be increased at the distal region 1082 of the adjustment tool shaft 1006, particularly in the region immediately proximal to the gear/fitting at the distal tip of the adjustment tool 1006. This gear/fitting is constrained orthogonally to the adjustable member 1004, and it is important that the adjustment tool 1006 be easy to insert/connect and remain clear of biological structures.

[0160] FIG. 50 provides a view of an embodiment of the proximal end of the adjustment tool 1006. Referring to FIG. 50, adjustment tool 1006 includes a flexible cable 1094 or similar structure that is affixed to and rotates with a handle 1996. In other embodiments, the adjustment tool 1006 can have cables, a band, tubes, rods, and the like to impart rotational and/or axial motion from the proximal end to the distal tip of the tool 1006. The flexible cable 1094 may be enclosed by a flexible, low-friction cable jacket 1098 that allows the cable 1094 to rotate freely within the jacket 1098. In some embodiments, adjustment tool 1006 may also include a spring release mechanism to allow disengagement of the distal tip of the tool from the docking port 1021 (FIG. 33) with minimal force being applied to the sutures (or other mechanisms) securing the implant device to the tissue of an anatomic orifice or lumen. As shown in FIG. 50, in some embodiments, an e-clip 1099 or similar device may be used near the handle 1996 of the adjustment tool 1006 to secure the release mechanism in the docking station until adjustments are complete.

[0161] In one embodiment illustrated in FIG. 51, the adjustment tool 1006 may be inserted inside a rigid sheath 1092 that reaches the implantable device 1002. Thus, FIG. 51 is a schematic view of an embodiment of the implantable device system 1000 of the present invention with an articulated shape. The rigidity of the sheath 1092 provides the necessary column strength to support the flexible adjustment tool 1006. An added benefit to this embodiment is that the sheath may be left in place, docked to the implantable device 1002. The flexible adjustment tool 1006 may be removed

and then reinserted at some future time to engage with the adjustable member 1004 of implantable device 1002.

[0162] The adjustment tool 1006 can have a handle 1096 that can be adjustable. The handle 1096 can have a length of at least 8 inches, and in one embodiment at least 10 inches. Other embodiments may have a shorter or longer handle length. The handle 1096 may be thick to provide a hand-grip, or, in other embodiments, smaller to provide a pen-like grip. The handle can have a device to quantify a size change of the implantable device 1002. For example, a half-turn of the adjustment tool handle can be correlated to a distance of travel of the threaded rods 1018a, 1018b (FIG. 33) of an implant 1002, thus allowing for measured adjustment of the implant. The handle may include a click-counter or other known device to measure rotational movement. In one embodiment, the adjustment tool 1006 may be included in a percutaneous delivery catheter.

[0163] A sensor, such as the touchdown sensor described in relation to FIGS. 12-18 above, can be coupled to the implantable device 1002. A variety of different sensors can be utilized, including but not limited to, sensors that measure pressure, temperature and flow across the implantable device 1002. Pacing leads are coupled to the sensor and the implantable device 1002, and in this embodiment, the sensor is responsive to flow through the implantable device 1002.

[0164] In another embodiment the implantable device system may include a micro-electromechanical motor system in conjunction with or instead of a separate adjustment tool to commence rotational movement in an adjustable member. Power and control of the micro-electromechanical motor system can be provided by electromagnetic radiation or through a direct wire connection and previously described herein.

[0165] Finally, it will be understood that the preferred embodiment has been disclosed by way of example, and that other modifications may occur to those skilled in the art without departing from the scope and spirit of the appended claims.

1. An implantable device system for controlling at least one of the shape and size of an anatomical structure or lumen, comprising:

an implantable device adapted for attachment to an anatomical structure or lumen, said implantable device comprising an adjustable member configured to receive an adjustment tool and configured to both increase and decrease the dimensions of the implantable device; and

a torqueable adjustment tool configured to provide adjustment of the dimensions of the implantable device, wherein adjustment of said adjustable member adjusts the size of the implant device generally in a preferred dimension.

2. The system of claim 1, wherein said implantable device comprises at least one hollow tube and at least one threaded rod threadedly engaged therewith such that rotation of the threaded rod causes the threaded rod to move axially within the hollow tube.

3. The system of claim 2, wherein said implantable device comprises an inner cable to translate rotational motion to said threaded rod.

4. The system of claim 1, wherein said implantable device comprises a flexible tube covering the outer layer of said implant device.

5. The system of claim 1, wherein adjustment of said adjustable member adjusts the size of the implant device generally in an anterior-posterior dimension.

6. The system of claim 1, further comprising a sensor coupled to the implantable device.

7. The system of claim 6, wherein the sensor measures at least one of pressure, temperature, and flow across the implantable device.

8. The system of claim 1, wherein said adjustment tool comprises a handle, said handle including a member to quantify a size change of the implantable device.

9. The system of claim 1, wherein said adjustment tool is configured to impart reciprocating action to the adjustable member.

10. The system of claim 9, wherein said adjustable member comprises a clover gear to transmit radial torque.

11. The system of claim 10, wherein said adjustable member converts axial force applied from said adjustment tool to a rotation force applied to the implantable device.

12. The system of claim 1, wherein said adjustment tool is configured to provide both course adjustment and fine adjustment of said implantable device.

13. An implantable device system for controlling at least one of the shape and size of an anatomical structure or lumen, comprising:

an implantable device adapted for attachment to an anatomical structure or lumen, said implantable device having a first band and a second band and an adjustable member configured to both increase and decrease the dimensions of the implantable device, said adjustable member configured to receive an adjustment tool;

a torqueable adjustment tool configured to provide adjustment of the dimensions of the implantable device, wherein adjustment of said adjustable member adjusts the size of the implant device generally in a preferred dimension.

14. The system of claim 13, wherein the first band and the second band are overlappable.

15. The system of claim 13, wherein the first band and the second band are slidable relative to each other.

16. The system of claim 13, wherein the adjustable member is configured to pull the first band and the second band toward each other.

17. The system of claim 13, wherein the at least one of said first and second bands has portions of varying durometer.

18. An implantable device system for controlling at least one of the shape and size of an anatomical structure or lumen, comprising:

an implantable device adapted for attachment to an anatomical structure or lumen, said implantable device comprising at least one adjustable member configured to receive an adjustment tool and configured to both increase and decrease the dimensions of the implantable device, wherein the implantable device includes dual threads that provide preferential adjustment of one side of the implantable device.

a torqueable adjustment tool configured to provide adjustment of the dimensions of the implantable device.

19. The system of claim 18, wherein said implantable device comprises at least one hollow tube and at least one threaded rod threadedly engaged therewith such that rotation of the threaded rod causes the threaded rod to move axially within the hollow tube.

20. The system of claim 19, wherein said implantable device comprises at least one inner cable to translate rotational motion to said threaded rod.

21. An implantable device adapted for attachment to an anatomical structure or lumen for controlling the size and/or shape of the anatomical structure or lumen, said device comprising:

an anterior region comprising one or more hollow rigid tube threadedly engaged with one or more threaded rods;

a posterior region comprising one or more hollow rigid tubes and an adjustable member configured to translate rotational motion to at least one inner cable;

said inner cable operatively connected to said adjustable member and said threaded rod so as to translate rotational motion from said adjustable member to said screw, wherein rotation of said screw can both increase and decrease the dimensions between the anterior region and the posterior region.

22. The implantable device of claim 21, further comprising at least one flexible tube that covers at least a portion of the anterior region and the posterior region.

23. The implantable device of claim 21, further comprising a micro-electromechanical motor system to commence rotational movement in said adjustable member.

* * * * *

专利名称(译)	用于控制解剖结构或内腔的尺寸的可植入装置		
公开(公告)号	US20080027483A1	公开(公告)日	2008-01-31
申请号	US11/802264	申请日	2007-05-21
[标]申请(专利权)人(译)	MITRALSOLUTIONS		
申请(专利权)人(译)	mitralsolutions , Inc.		
当前申请(专利权)人(译)	ST.犹达医疗用品, 心脏病DIVISION, INC.		
[标]发明人	CARTLEDGE RICHARD G LEE LEONARD Y FANN JAMES I FRIEDMANN JOSEF L GREEN JAMES L		
发明人	CARTLEDGE, RICHARD G. LEE, LEONARD Y. FANN, JAMES I. FRIEDMANN, JOSEF L. GREEN, JAMES L.		
IPC分类号	A61B17/08 A61B17/00 A61B17/58 A61B5/00 A61B17/064 A61B17/068 A61F2/00 A61F2/02 A61F2/04 A61F2/24 A61F2/82		
CPC分类号	A61B5/061 A61F2/2442 A61B6/12 A61B17/00234 A61B17/0644 A61B17/068 A61B2017/00243 A61B2017/00455 A61B2017/00783 A61B2017/0496 A61B2017/0641 A61B2019/462 A61F2/0031 A61F2/2445 A61F2/2448 A61F2/2466 A61F2002/30537 A61F2250/0004 A61F2250/0029 A61B5/6885 A61B2090/062		
优先权	60/801861 2006-05-19 US 60/406841 2002-08-29 US 60/462435 2003-04-12 US 60/447383 2003-02-14 US 60/444005 2003-01-31 US		
其他公开文献	US8758372		
外部链接	Espacenet USPTO		

摘要(译)

用于控制内部解剖学通道的尺寸的可植入装置系统校正由结构管腔导致的生理功能障碍, 所述结构管腔太大或太小。公开了可植入装置, 其采用各种机构来调节和保持它们所连接的孔的尺寸。系统允许使用微创手术植入植入物, 并允许在原位恢复正常解剖流体流后对植入物的尺寸进行最终调整。

