



US 20070032739A1

(19) **United States**

(12) **Patent Application Publication**

Hashimshony et al.

(10) **Pub. No.: US 2007/0032739 A1**

(43) **Pub. Date: Feb. 8, 2007**

(54) **DEVICE FOR FORMING AN EFFECTIVE SENSOR-TO-TISSUE CONTACT**

(52) **U.S. Cl. 600/552**

(75) Inventors: **Dan Hashimshony**, Givat Ada (IL); **Gil Cohen**, Jerusalem (IL); **Iddo Geltner**, Herzlia (IL)

(57) **ABSTRACT**

Correspondence Address:
Martin Moynihan
c/o **Anthony Castorina**
Suite 207
2001 **Jefferson Davis Highway**
Arlington, VA 22202 (US)

A device and method for tissue characterization are provided, the device comprising: a structure; a first mechanism, associated with said structure, configured for exerting a first force on a tissue, for fixing the tissue to said structure, so as to substantially immobilize the tissue; and a second mechanism, associated with said structure, configured for pressing a sensor against an external surface of the immobilized tissue, thereby exerting a second force on the immobilized tissue, wherein at least a component of said first force is in opposition to at least a component of said second force, forcing the immobilized tissue against said sensor, and forcing said sensor against the immobilized tissue, bringing about an effective contact between said sensor and the immobilized tissue.

(73) Assignee: **Dune Medical Devices Ltd.**, Caesaria (IL)

(21) Appl. No.: **11/196,732**

(22) Filed: **Aug. 4, 2005**

Publication Classification

(51) **Int. Cl. A61B 5/00 (2006.01)**

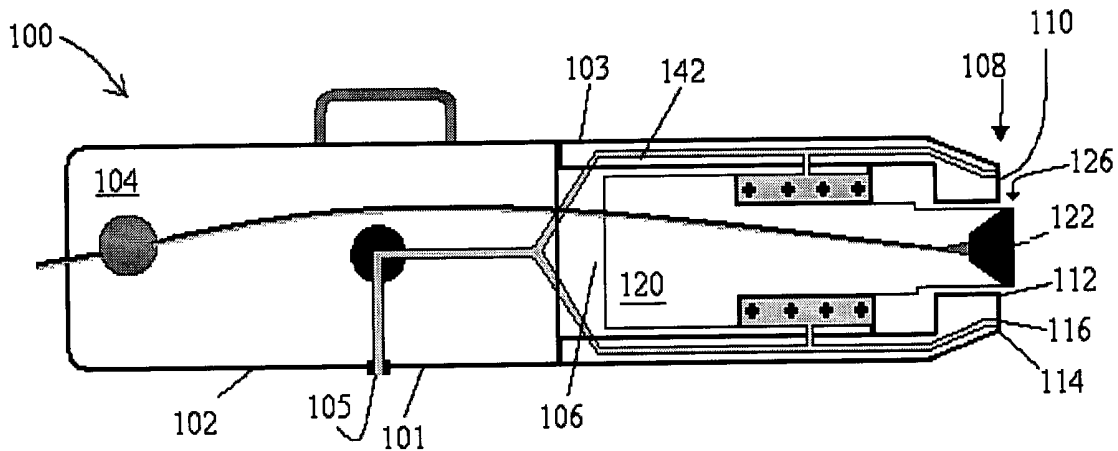

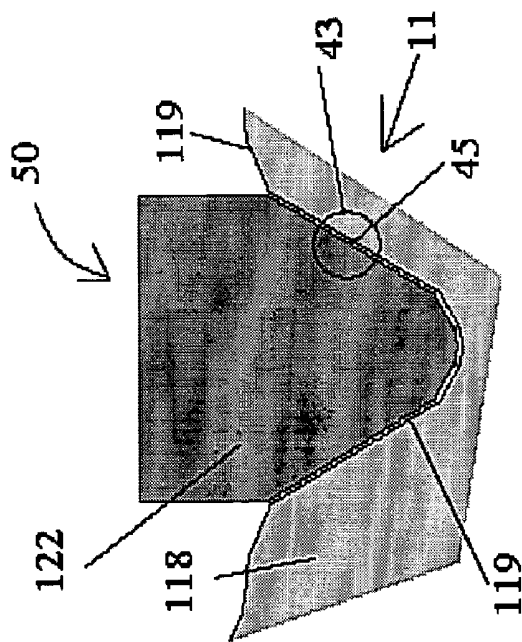

Cross-Sectional View
Figure 1A

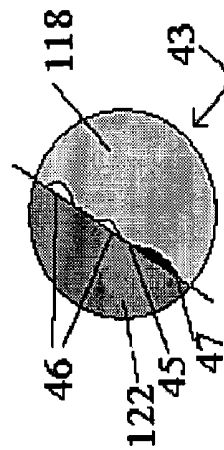

Cross-Sectional View
Figure 1B

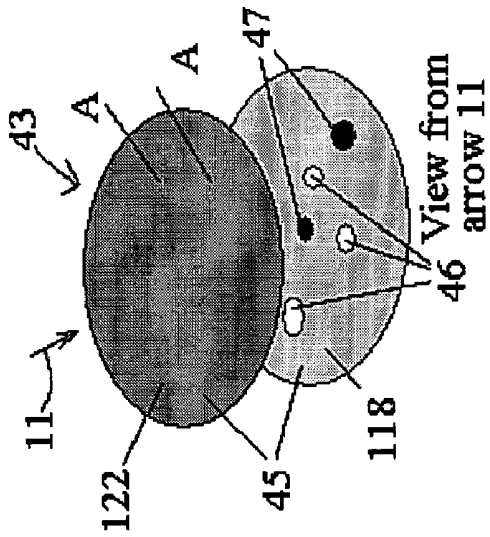

View from
arrow 11
Figure 1D

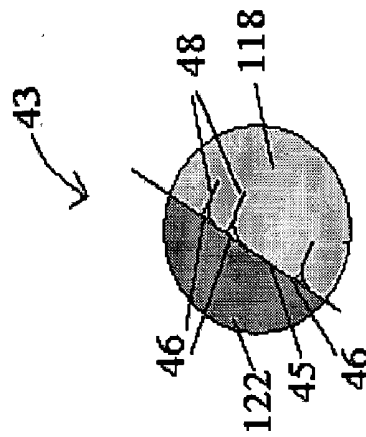

Cross-Sectional View
Figure 1C

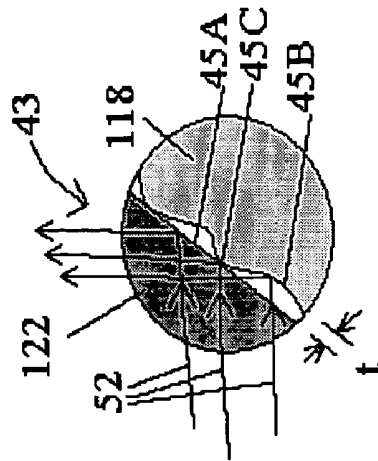

Cross-Sectional View
Figure 1E

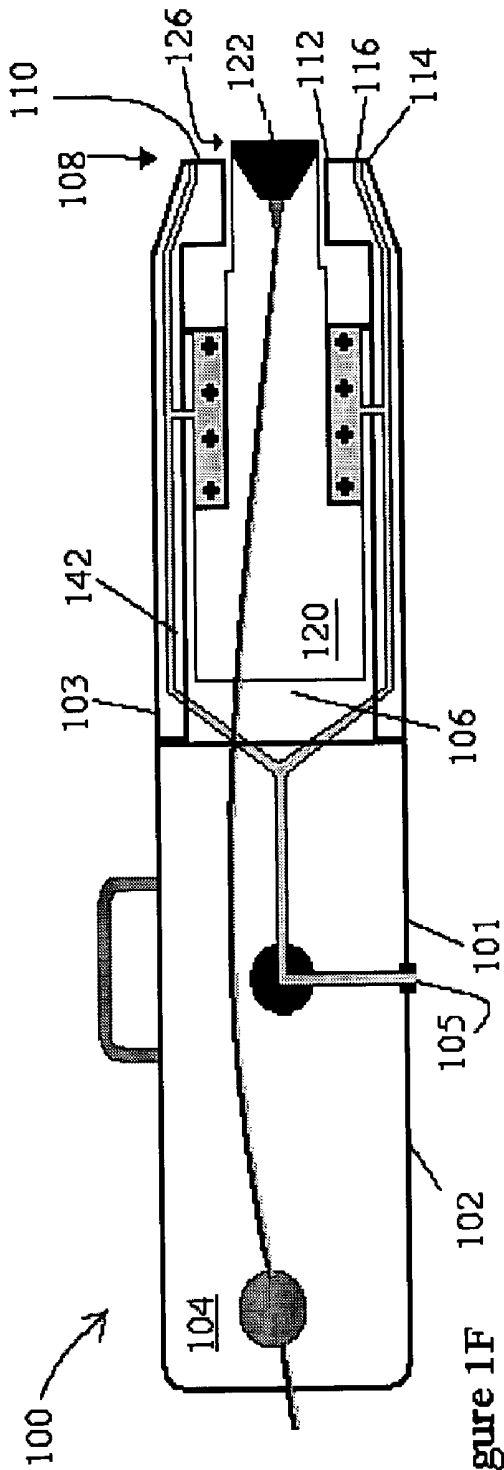
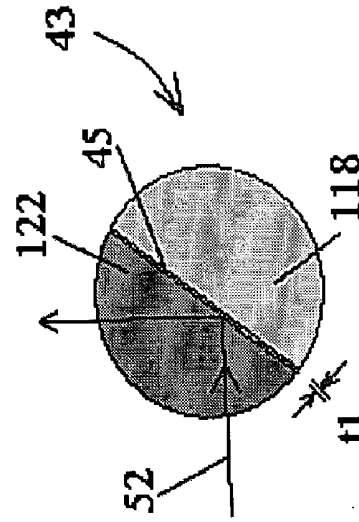

Figure 1F



Cross-Sectional View
Figure 1H

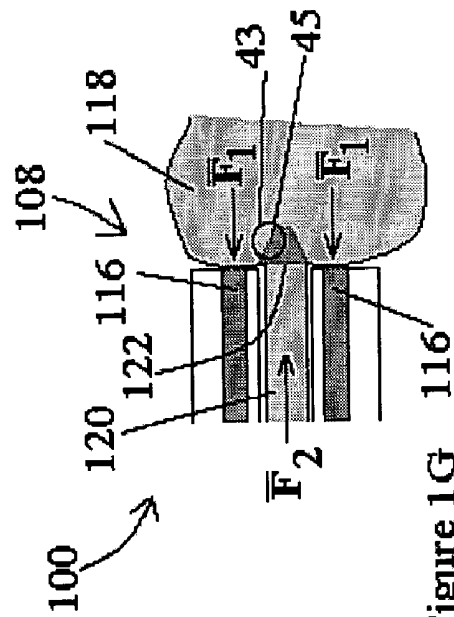
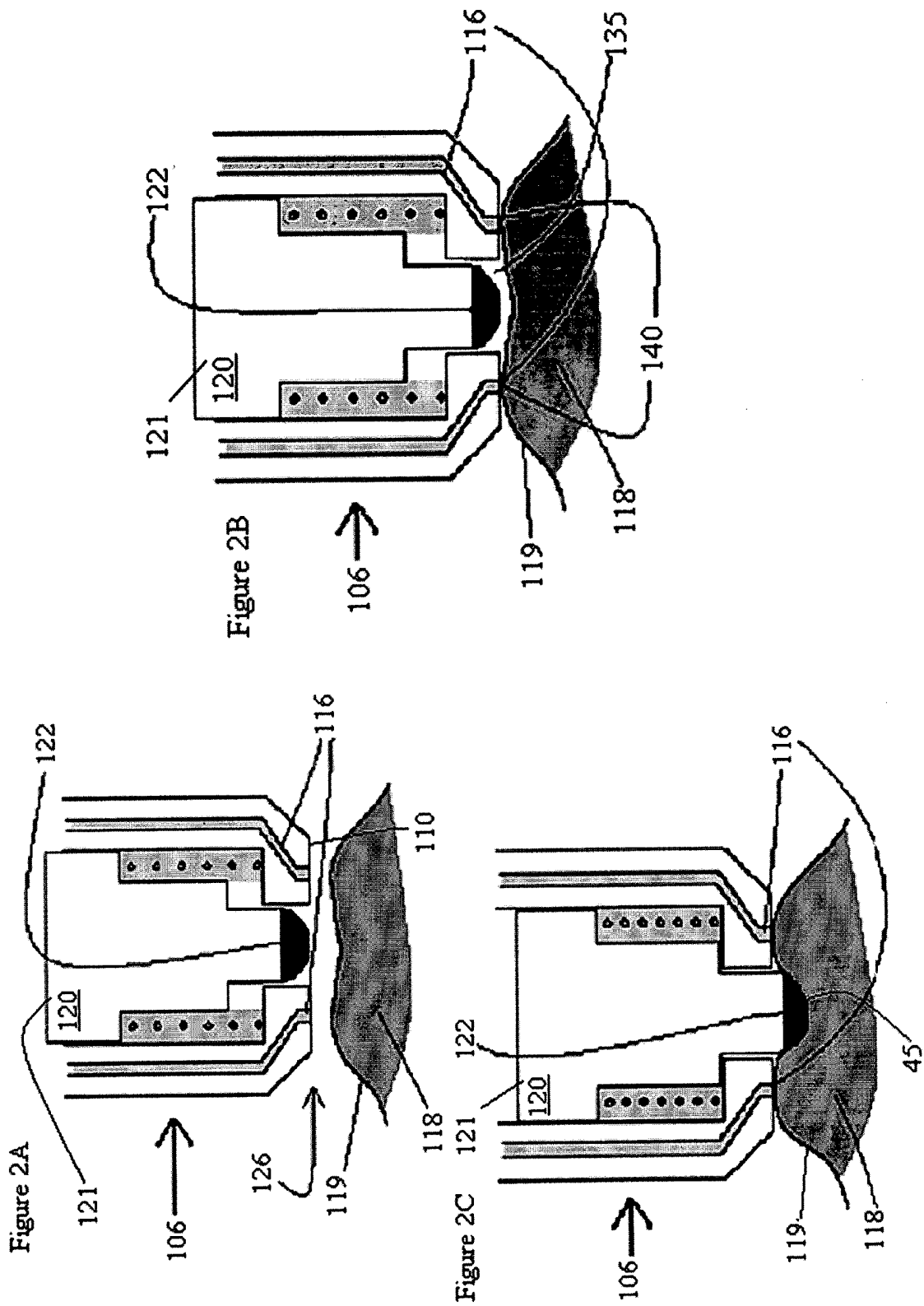

Figure 1G



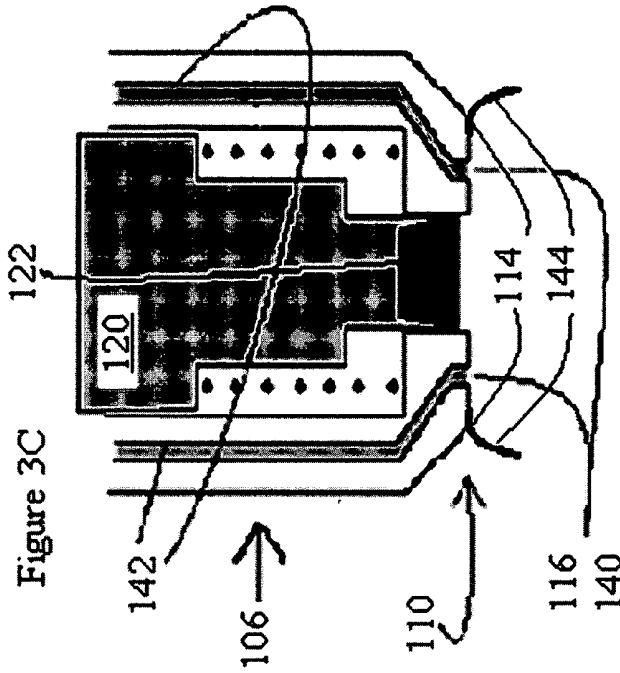

Figure 3C

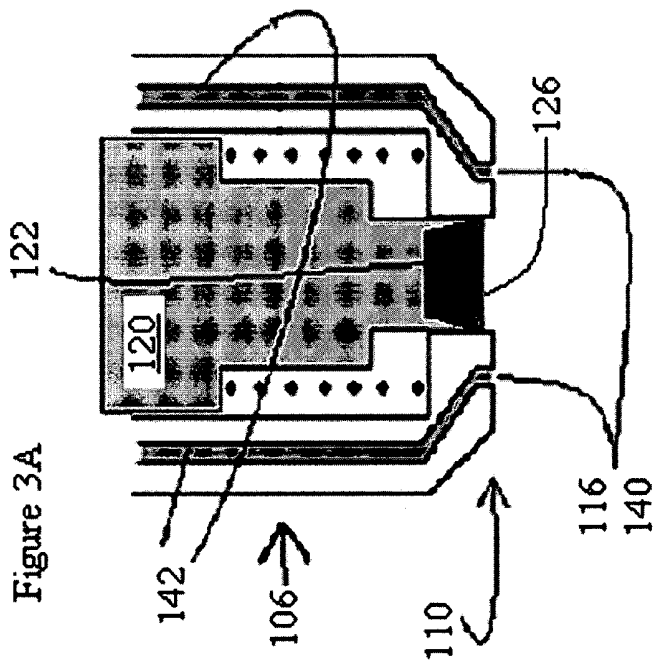

Figure 3A

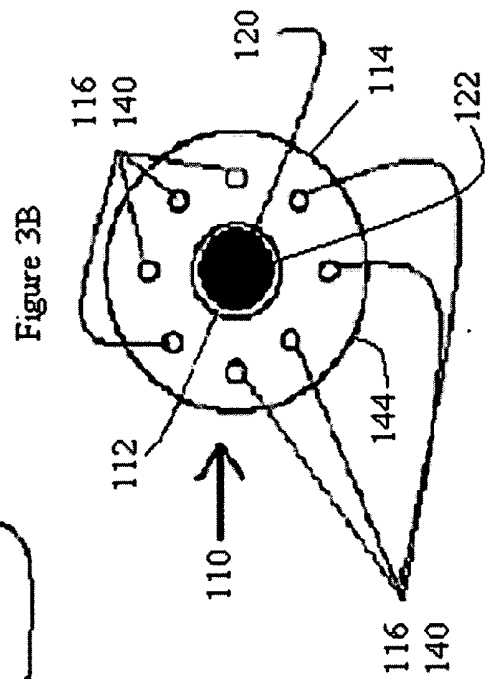

Figure 3B

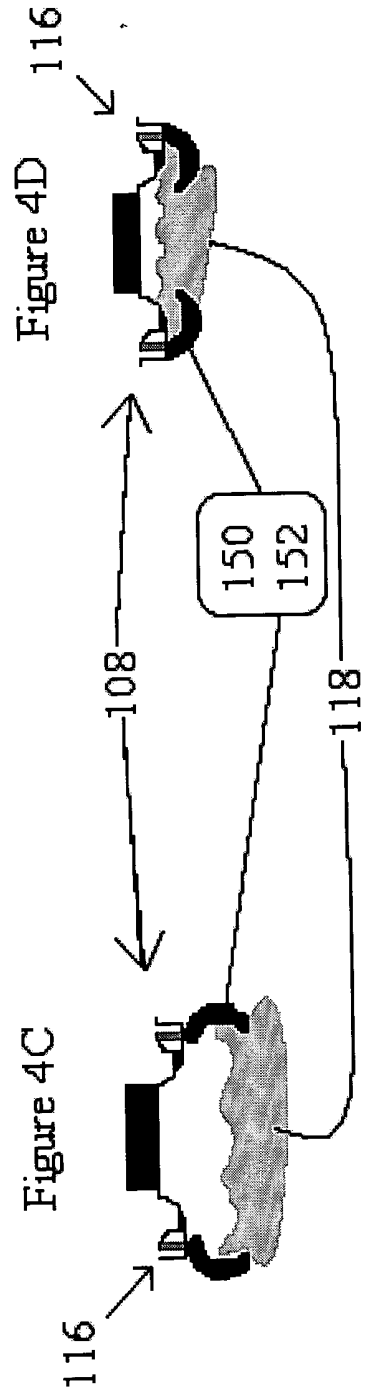
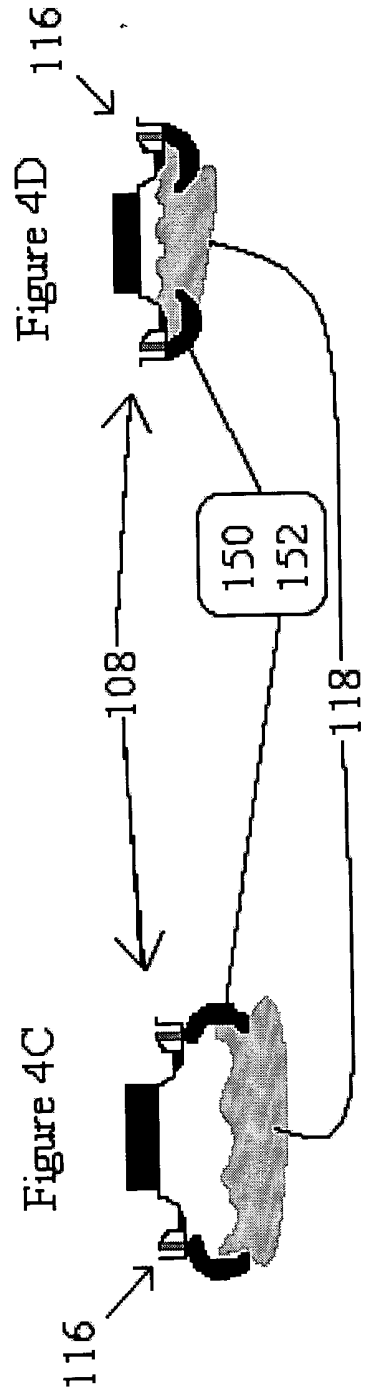
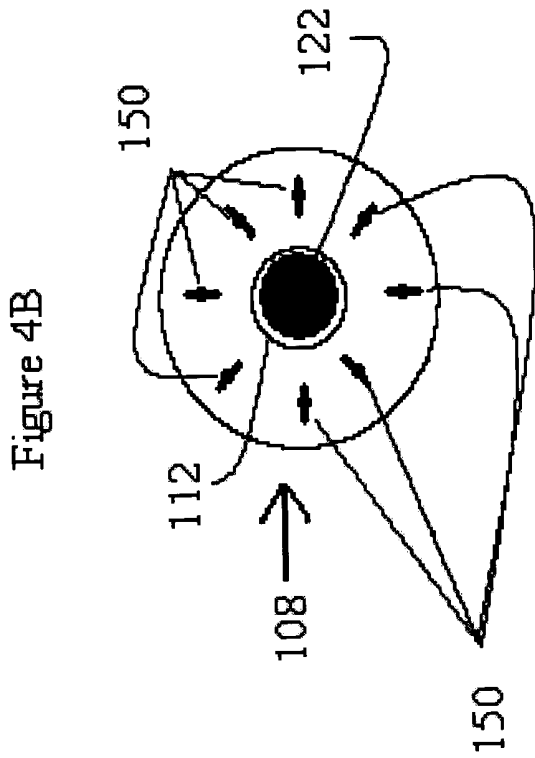
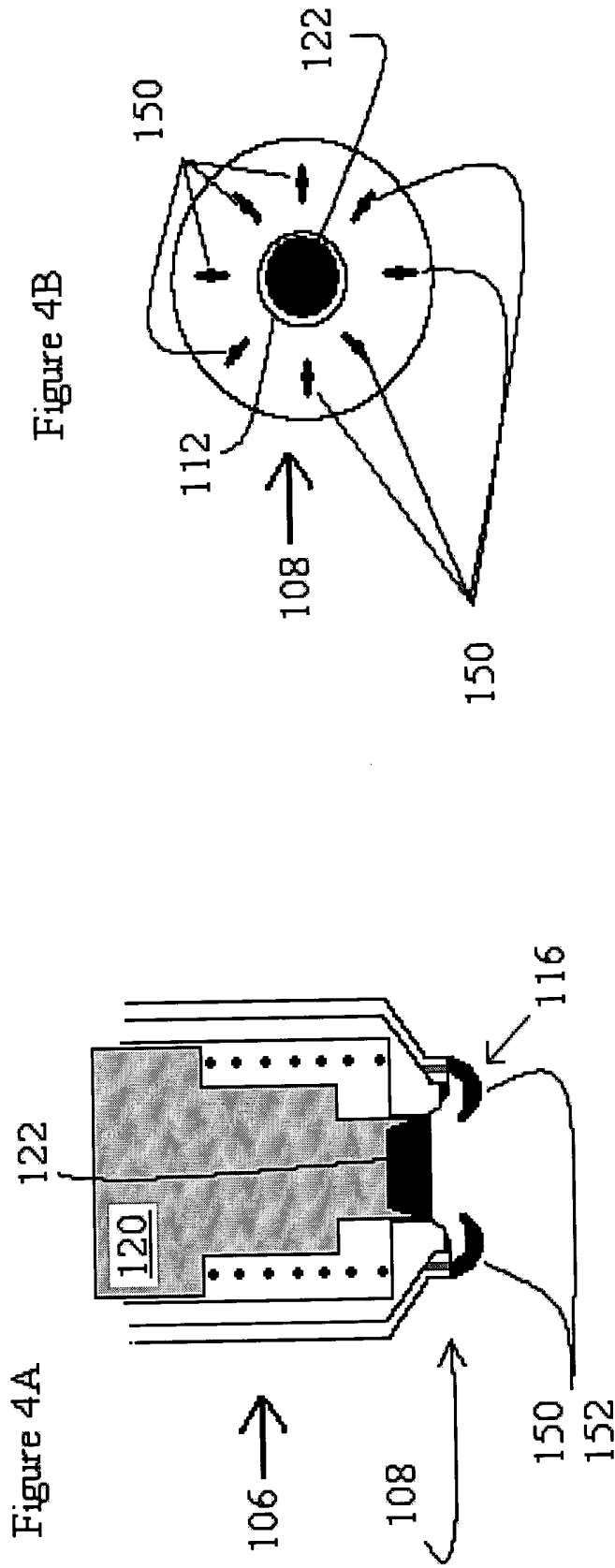

Figure 5 B

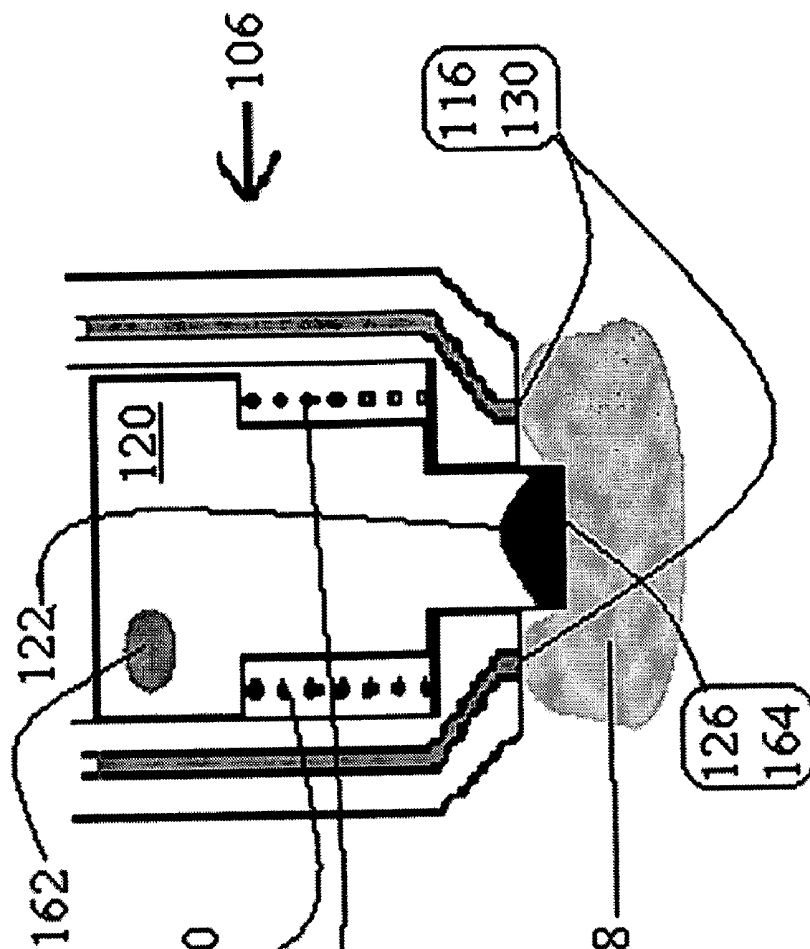
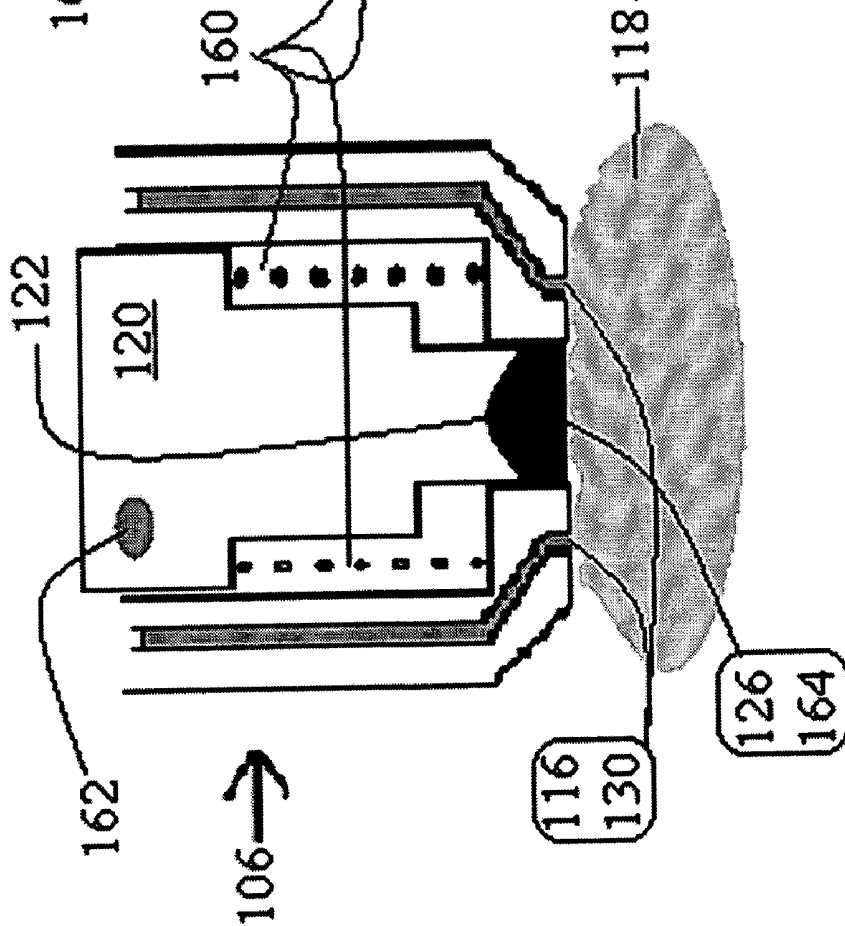

Figure 5 A



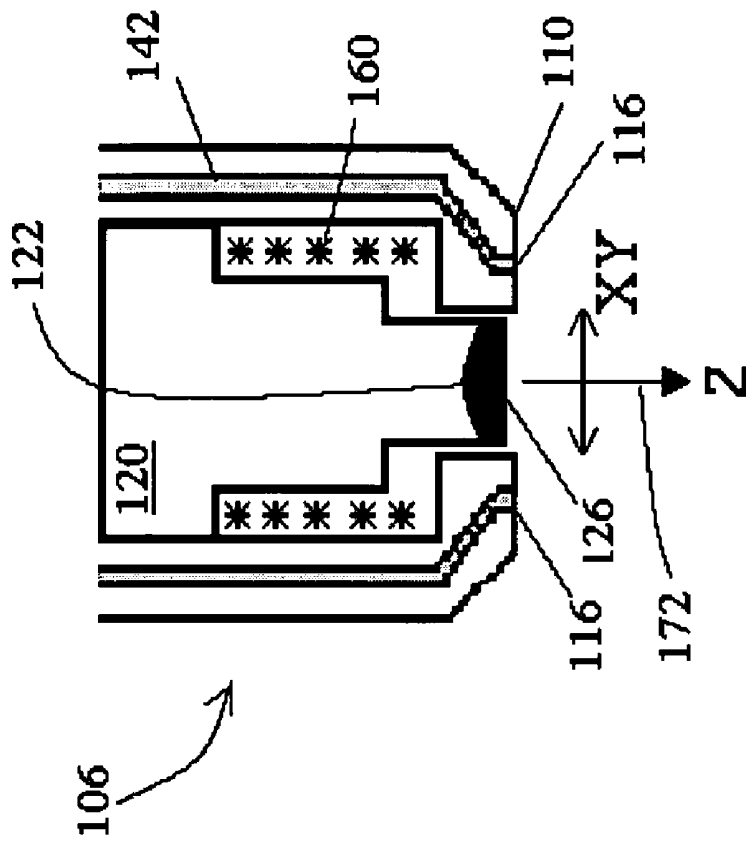

Figure 7

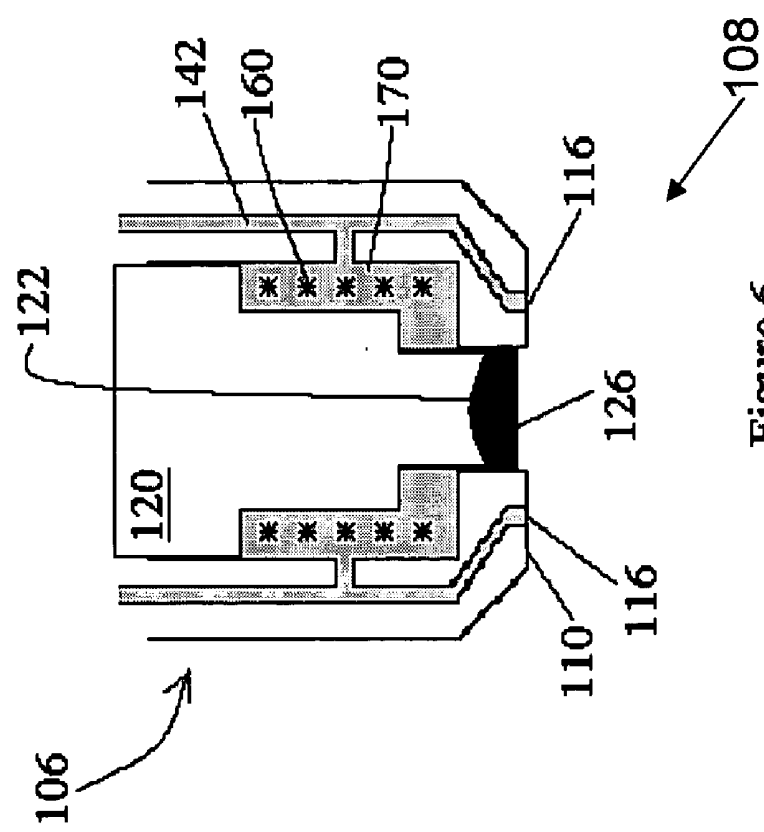
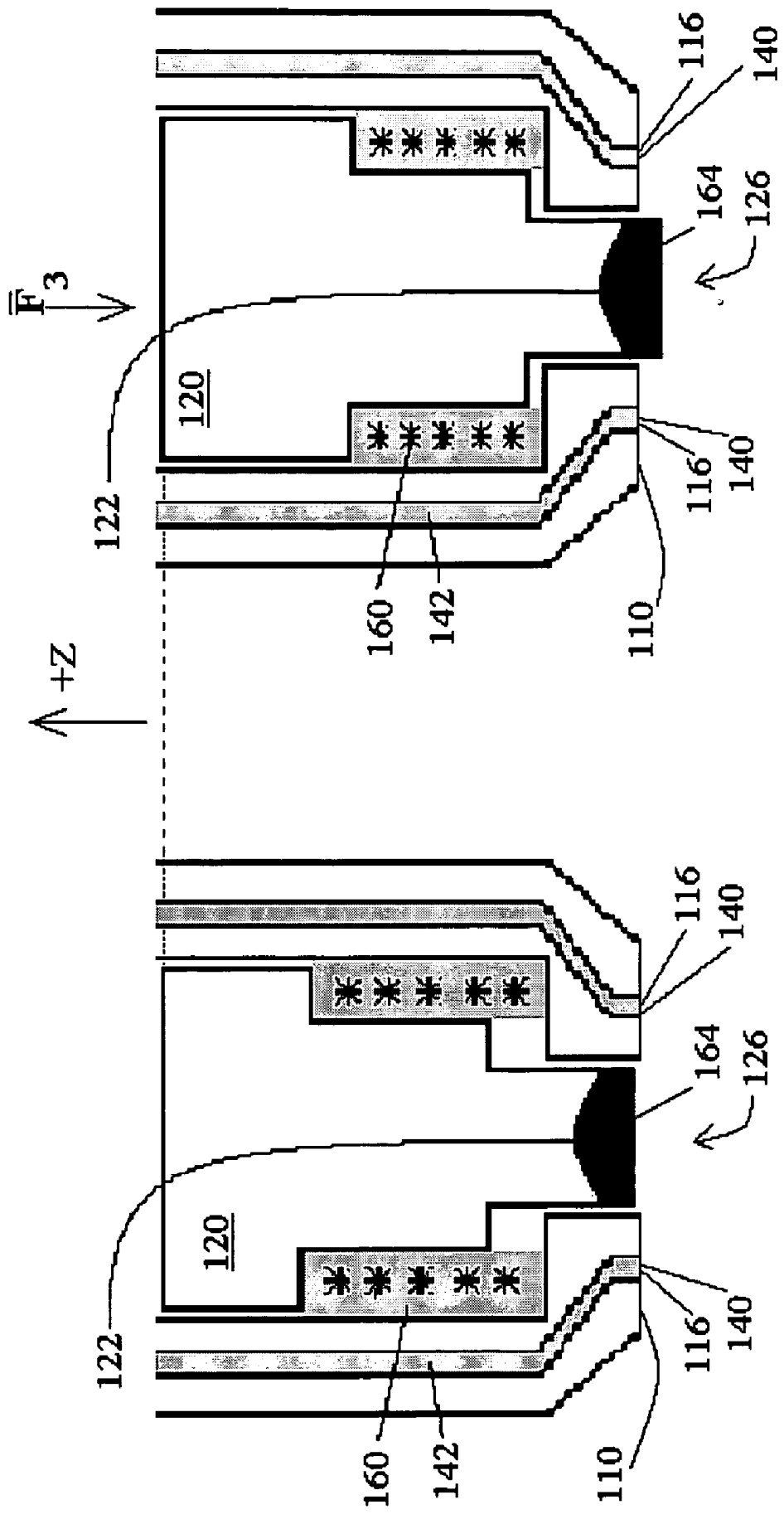

Figure 6



Piston Deployed
Figure 8D

Piston Retracted
Figure 8C

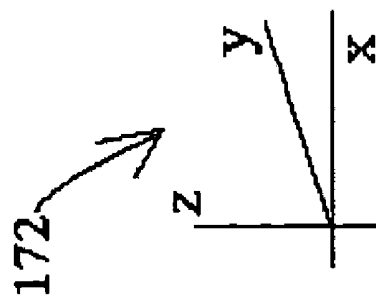

Figure 9A

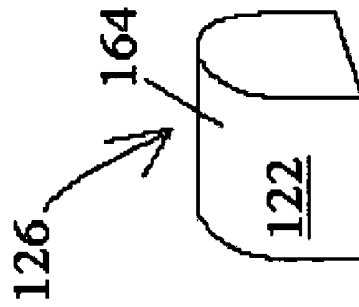

Figure 9B

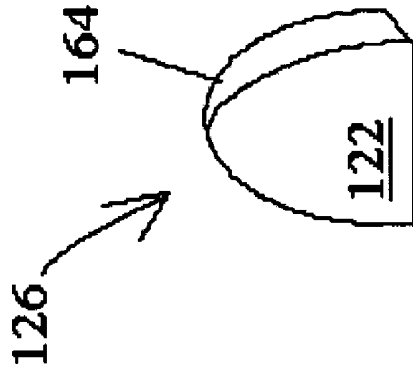

Figure 9C

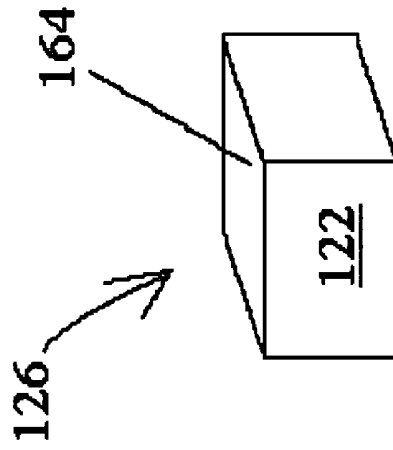

Figure 9D

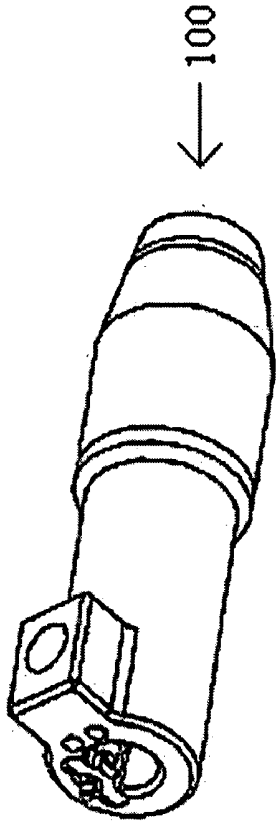

Figure 10A

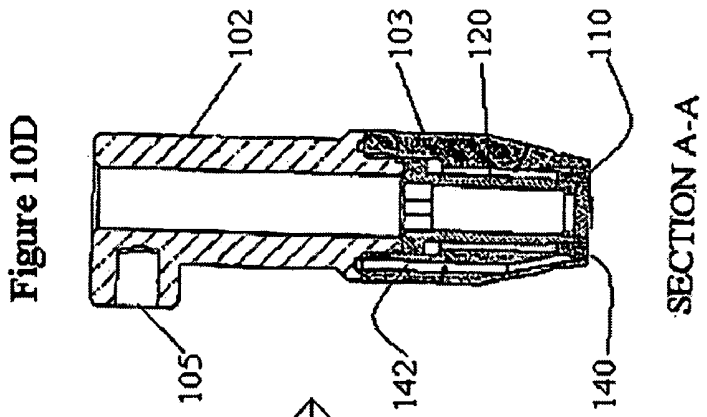

Figure 10D

Figure 10C

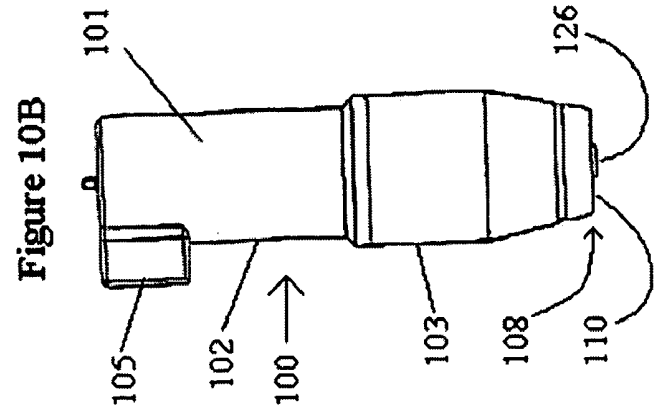
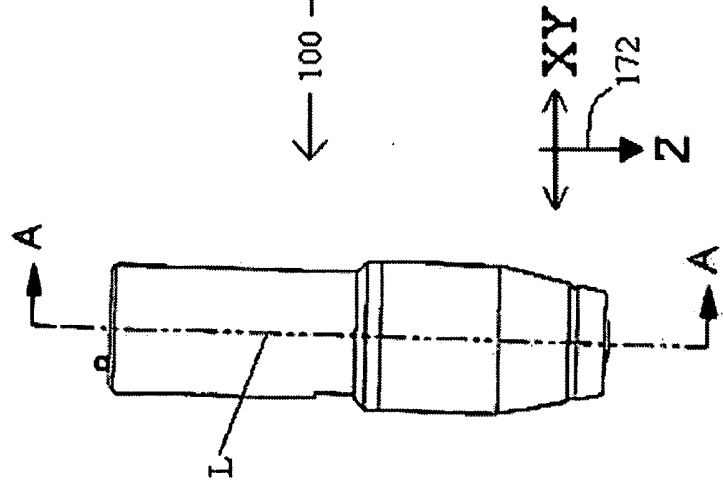

Figure 10B

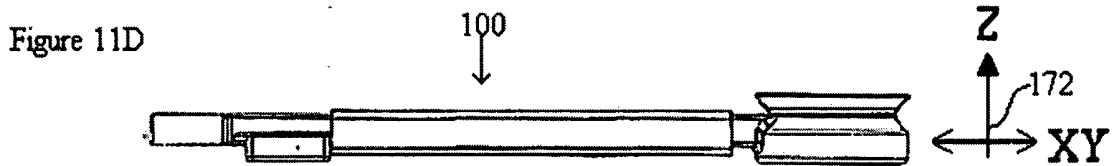
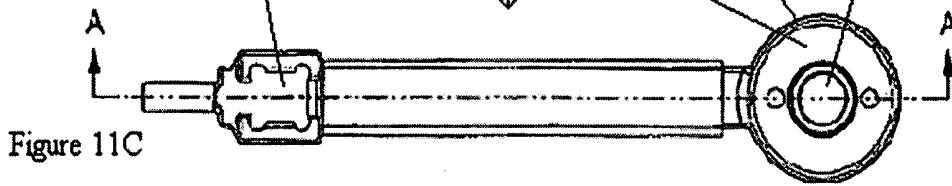
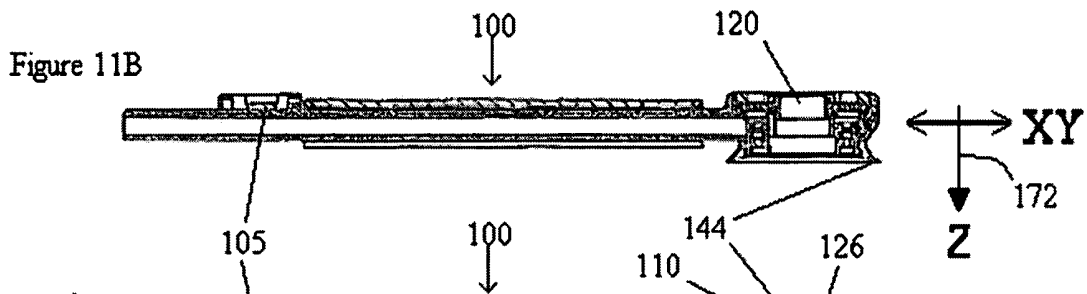
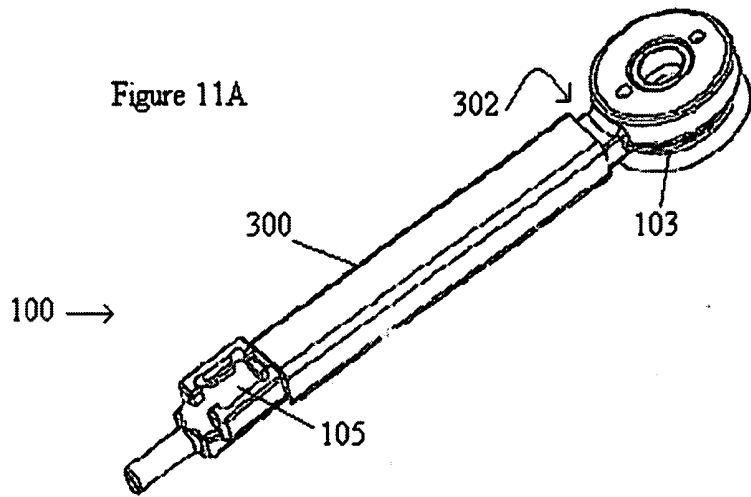
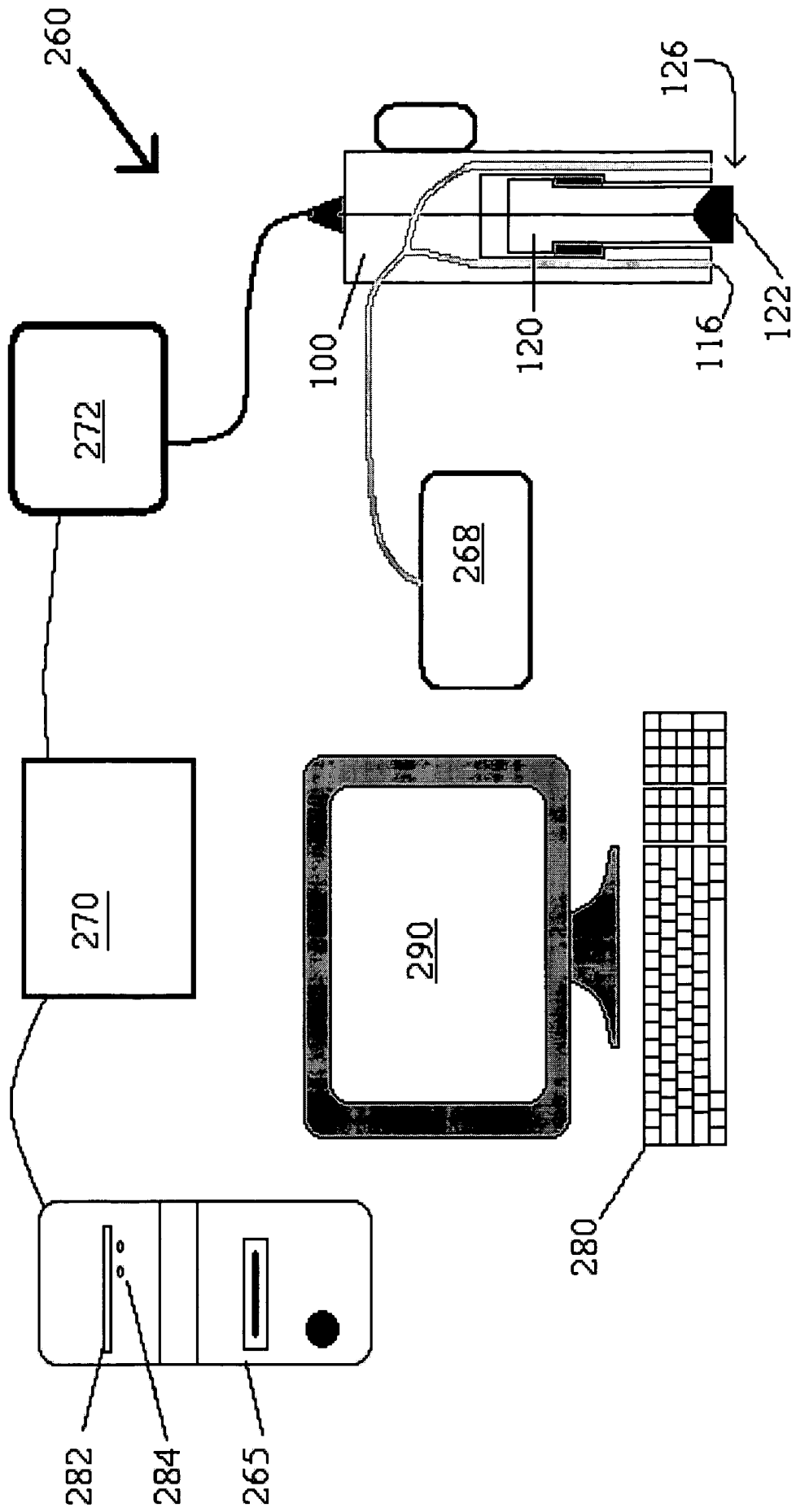

Figure 12



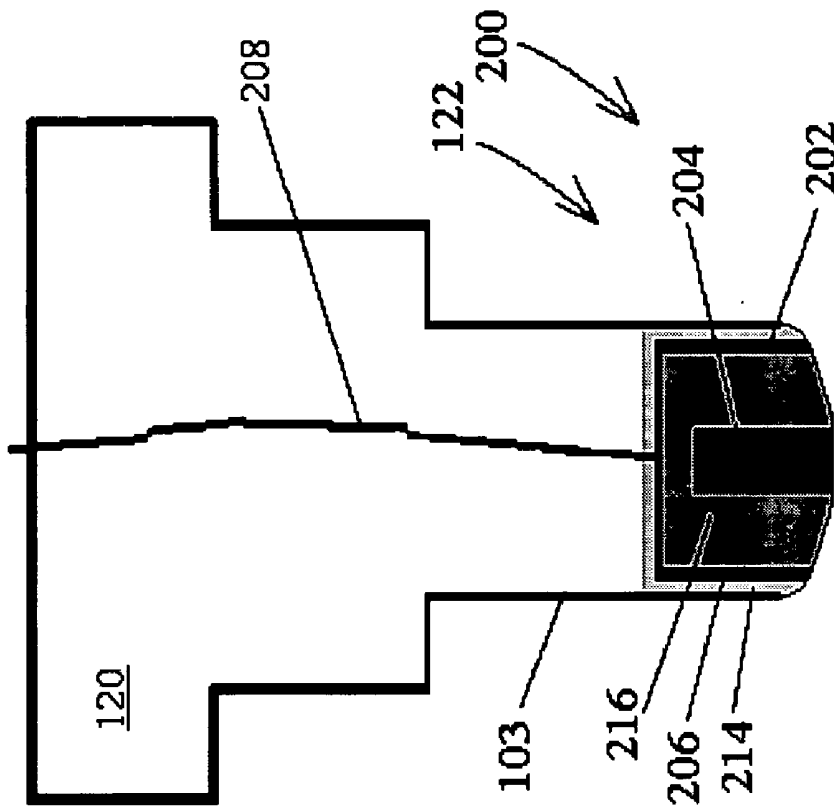

Figure 13A

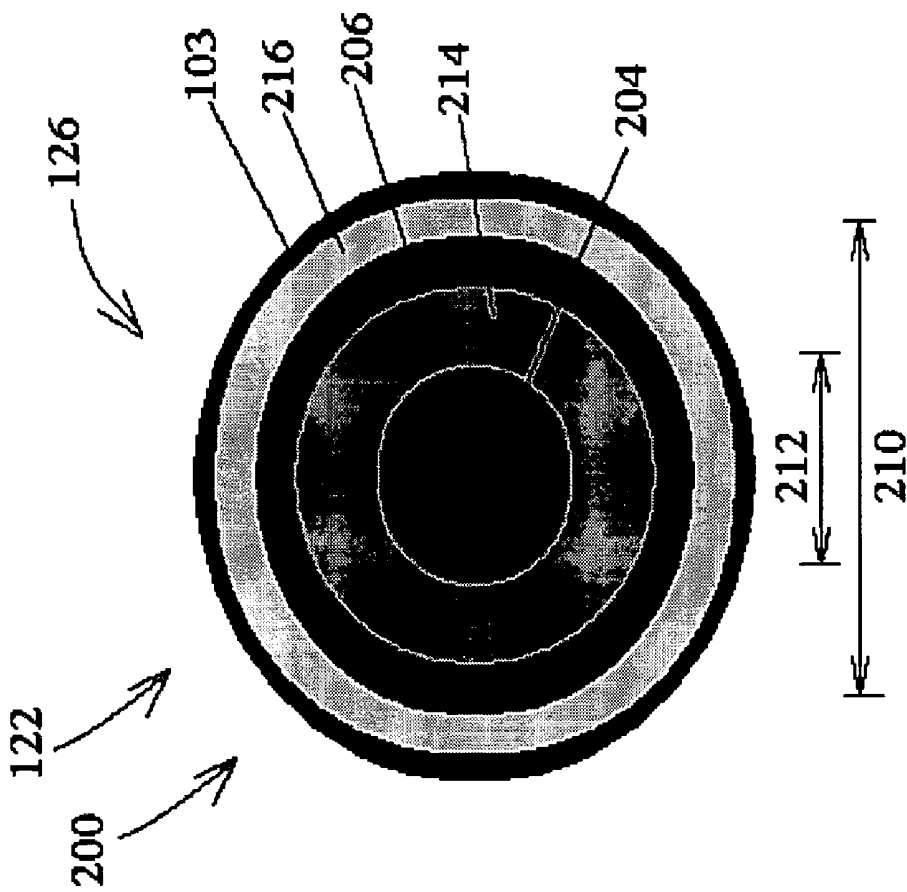

Figure 13B

Figure 13 C

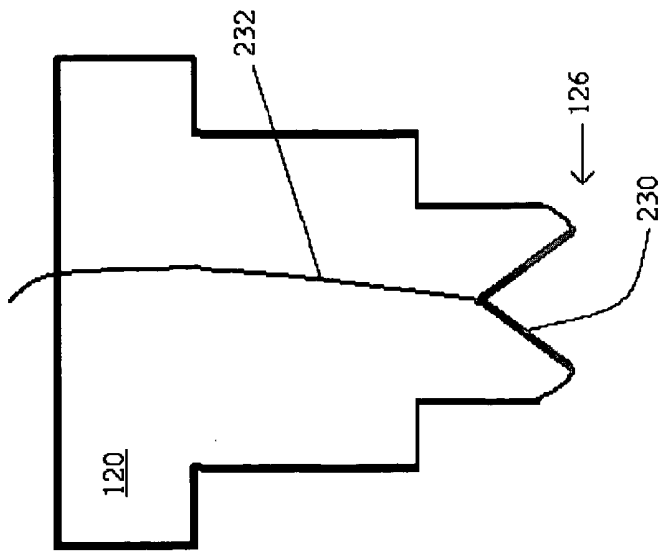

Figure 13 D

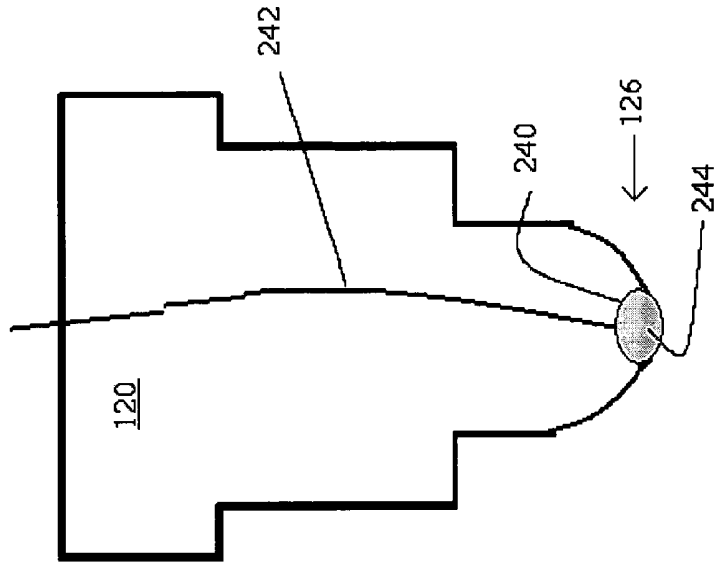
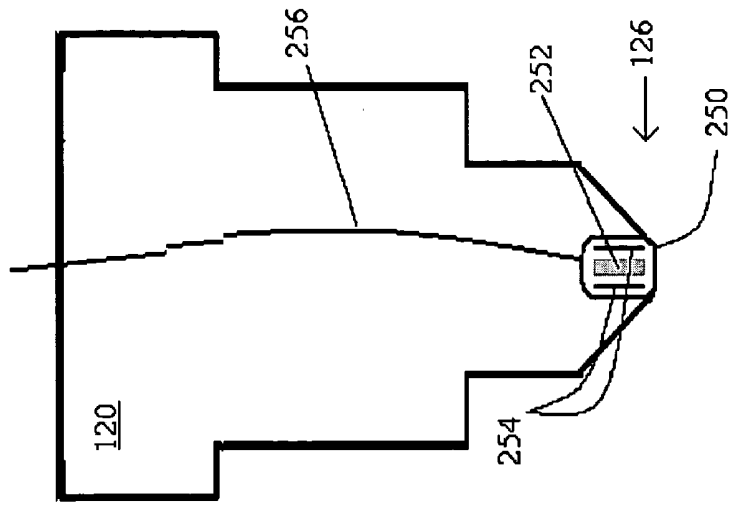

Figure 13 E



**DEVICE FOR FORMING AN EFFECTIVE
SENSOR-TO-TISSUE CONTACT****FIELD AND BACKGROUND OF THE
INVENTION**

[0001] The present invention relates generally, to tissue characterization, and specifically, to a device and method for forming effective sensor-to-tissue contact, for tissue characterization.

[0002] The use of suction, for engaging a medical instrument to a tissue, is known. For example: U.S. Pat. No. 5,727,569 to Benetti et al., entitled: "Surgical devices for imposing a negative pressure to fix the position of cardiac tissue during surgery", whose disclosure is incorporated herein by reference, teaches devices and techniques of using a negative (suction) pressure or vacuum, applied through surgical instruments for fixing the position of a portion of the surface of a beating heart so that a surgical procedure can be more easily performed. The devices apply negative pressure at several points on the outer surface of the heart such that a portion of the heart is fixed in place by the suction imposed through the surgical instrument. Because the instrument fixes the position of the tissue, and because the instruments remain at a constant distance from the particular portion of the heart where surgery is performed, the device may also serve as a support or platform so that other surgical instruments or devices can be advantageously used at the site. In certain preferred embodiments, the devices described are structured to facilitate the use of additional surgical instruments such that the placement of negative pressure device permit the surgeon to advantageously manipulate the other instruments during surgery. The negative pressure is preferably imposed through a plurality of ports that may be disposed in a substantially planar surface of the instrument that contacts the cardiac tissue.

[0003] In addition, U.S. Pat. No. 5,927,284, to Borst, entitled, "A Method and Apparatus for Temporarily Immobilizing a Local Area of Tissue," whose disclosure is incorporated herein by reference, describes temporarily immobilizing a local area of heart tissue to permit surgery on a coronary vessel in that area without significant deterioration of the pumping function of the beating heart. The local area of heart tissue is immobilized to a degree sufficient to permit minimally invasive or micro-surgery on that area of the heart. A suction device is used to accomplish the immobilization. The suction device is coupled to a source of negative pressure. The suction device has a series of suction ports on one surface. Suction through the device causes suction to be maintained at the ports. The device is shaped to conform to the surface of the heart. Thus, when the device is placed on the surface of the heart and suction is created, the suction through the ports engages the surface of the heart. The suction device is further fixed or immobilized to a stationary object, such as an operating table or a sternal or rib retractor. Thus, the local area of the heart near the suction device is temporarily fixed or immobilized relative to the stationary object while suction is maintained. In this fashion, the coronary artery may be immobilized, even though the heart itself is still beating so that a bypass graft may be performed. In addition, the suction device may be used in either a conventional, open-chest environment or in a minimally-invasive, endoscopic environment.

[0004] U.S. Pat. No. 6,728,565, to Wendlandt, entitled, "Diagnostic Catheter Using a Vacuum for Tissue Position-

ing," whose disclosure is incorporated herein by reference, describes the use of a diagnostic catheter, associated with a vacuum source, for attaching a sensor to a tissue surface. The method includes inserting a catheter with a sensor at its distal end into the body of a patient, applying suction through the catheter, to draw tissue into a predetermined sensing position for the sensor, and analyzing the tissue with the sensor. The degree of vacuum may be adjusted, so that only the required amount of force is used to maintain contact between the sensor or sensors and the tissue being analyzed.

[0005] U.S. Pat. No. 6,090,041, to Clark, entitled, "Vacuum Actuated Surgical Retractor and Methods," whose disclosure is incorporated herein by reference, describes a surgical retractor for retracting body tissue or organs, using suction. The surgical retractor includes an end piece adapted for sealing engagement with body tissue, the end piece having at least one suction port therein, the at least one suction port operably linked to at least one vacuum line. Suction supplied to the at least one suction port may be controlled by a vacuum control unit. Retractors of the invention may be provided in a range of shapes and sizes, according to the intended application or tissue to be retracted. A method for making a vacuum actuated retractor of the invention is disclosed, together with a method for automatically retracting body tissue.

[0006] U.S. Pat. No. 6,695,782 to Ranucci et al., teaches an ultrasonic tissue ablation device comprising a transversely elongated probe and a coupling assembly for probe attachment and detachment that enables the probe assembly and separation from the device body that includes the ultrasound energy source and sound conductor, and a method of use for removal of vascular occlusions in blood vessels. The coupling assembly enables incorporation of elongated probes with small cross sectional lumens such as a catheter guide wire. The probe can be used with acoustic and/or aspiration sheaths to enhance destruction and removal of an occlusion. The horn assembly of the device that contains a sound conducting horn functions as an energy regulator and reservoir for the probe, and precludes loss of probe cavitation energy by its bending or damping within the blood vessel.

[0007] U.S. Pat. No. 6,500,112, to Khouri, entitled, "Vacuum dome with supporting rim and rim cushion," whose disclosure is incorporated herein by reference, describes the use of vacuum for tissue stretching, to enlarge a soft tissue, for example after a breast surgery, or to correct a deformity. It utilizes a generally rigid dome, capable of withstanding a pressure differential, with a rim cushion underlying the rim of the dome, for supporting the rim against the patient's skin surface. The rim may be generally wider than the dome in order to distribute the attendant forces across a greater surface and avoid tissue damage. A sticky sole underlies the rim cushion and seals the rim cushion to the patient's skin, to thereby preserve the vacuum within the dome. The sticky sole may be any adhesive material or be achieved through the use of an appropriate material for the rim cushion itself. Unlike the other references, described hereinabove, in U.S. Pat. No. 6,500,112, the vacuum is used for its therapeutic effect, i.e., tissue stretching, to enlarge a soft tissue or to correct a deformity, rather than as means for attaching another instrument.

[0008] Different types of sensors and probes for tissue characterizations are known and available today. Even

though the operating principles of the different types of tissue characterization techniques differ, effective contact between the sensor and the tissue itself is often essential for reliable results. For example, the presence of air bubbles between an ultrasound tool and the tissue will interfere with ultrasound measurements. Similarly, a liquid layer may interfere with optical spectroscopy. There is thus a recognized need for devices and methods for ensuring effective contact between the sensor and the tissue, free of air, liquid and foreign matter.

SUMMARY OF THE INVENTION

[0009] The present invention successfully addresses the shortcoming of the presently known configurations by providing a device and method for tissue characterization, the device comprising: a structure; a first mechanism, associated with said structure, configured for exerting a first force on a tissue, for fixing the tissue to said structure, so as to substantially immobilize the tissue; and a second mechanism, associated with said structure, configured for pressing a sensor against an external surface of the immobilized tissue, thereby exerting a second force on the immobilized tissue, wherein at least a component of said first force is in opposition to at least a component of said second force, forcing the immobilized tissue against said sensor, and forcing said sensor against the immobilized tissue, bringing about an effective contact between said sensor and the immobilized tissue.

[0010] In accordance with an aspect of the present invention, there is thus provided a device for tissue characterization, comprising:

[0011] a structure;

[0012] a first mechanism, associated with the structure, configured for exerting a first force on a tissue, for fixing the tissue to the structure, so as to substantially immobilize the tissue; and

[0013] a second mechanism, associated with the structure, configured for pressing a sensor against an external surface of the immobilized tissue, thereby exerting a second force on the immobilized tissue,

[0014] wherein at least a component of the first force is in opposition to at least a component of the second force, forcing the immobilized tissue against the sensor, and forcing the sensor against the immobilized tissue, bringing about an effective contact between the sensor and the immobilized tissue.

[0015] In accordance with an additional aspect of the present invention, the effective contact is a contact level of 95%.

[0016] In accordance with an additional aspect of the present invention, the effective contact is a contact level of 99%.

[0017] In accordance with an additional aspect of the present invention, the effective contact is a contact level of 99.8%.

[0018] In accordance with an additional aspect of the present invention, the sensor is a sensor of a wavelength λ , and an average distance t_1 , between external-most surfaces of the tissue and the sensor is such that $t_1 < \lambda/3$.

[0019] In accordance with an additional aspect of the present invention, the sensor is a sensor of a wavelength λ , and an average distance t_1 , between external-most surfaces of the tissue and the sensor is such that $t_1 < \lambda/10$.

[0020] In accordance with an additional aspect of the present invention, the sensor is a sensor of a wavelength λ , and an average distance t_1 , between external-most surfaces of the tissue and the sensor is such that $t_1 < \lambda/100$.

[0021] In accordance with an alternative aspect of the present invention, an average distance t_1 , between external-most surfaces of the tissue and the sensor, is less than 500 Angstroms.

[0022] In accordance with an additional aspect of the present invention, an average distance t_1 , between external-most surfaces of the tissue and the sensor, is less than 50 Angstroms.

[0023] In accordance with an additional aspect of the present invention, an average distance t_1 , between external-most surfaces of the tissue and the sensor, is less than 5 Angstroms.

[0024] In accordance with an additional aspect of the present invention, the first mechanism is a suction source, for fixing and substantially immobilizing the tissue, by suction.

[0025] In accordance with an additional aspect of the present invention, the second mechanism is a piston, configured for sliding proximally and distally, and containing the sensor at a proximal end thereof.

[0026] In accordance with an additional aspect of the present invention, the piston is further configured for vibrating laterally, as it slides proximally, to provide a gliding-sweeping motion against the tissue.

[0027] In accordance with an additional aspect of the present invention, the piston is configured to slide proximally a predetermined distance.

[0028] In accordance with an alternative aspect of the present invention, the piston is configured to slide proximally until a predetermined force is reached.

[0029] In accordance with an additional aspect of the present invention, wherein the device further comprises a spring, for regulating the second force.

[0030] In accordance with an alternative aspect of the present invention, the first mechanism is a gripping device, for gripping the tissue.

[0031] In accordance with an additional aspect of the present invention, the sensor is selected from the group consisting of an optical sensor, an MRI sensor, an RF sensor, a MW sensor, an X-ray sensor, an ultrasound sensor, a temperature sensor, an infrared thermography sensor, a biosensor, a chemical sensor, and a mechanical sensor.

[0032] In accordance with an aspect of the present invention, there is thus provided a system for tissue characterization, comprising:

[0033] a device for tissue characterization, which comprises:

[0034] a structure;

[0035] a first mechanism, associated with the structure, configured for exerting a first force on a tissue, for fixing the tissue to the structure, so as to substantially immobilize the tissue; and

- [0036] a second mechanism, associated with the structure, configured for pressing a sensor against an external surface of the immobilized tissue, thereby exerting a second force on the immobilized tissue, wherein at least a component of the first force is in opposition to at least a component of the second force, forcing the immobilized tissue against the sensor, and forcing the sensor against the immobilized tissue, thus bringing about an effective contact between the sensor and the immobilized tissue; and
- [0037] a signal analyzer, in signal communication with the sensor.
- [0038] In accordance with an additional aspect of the present invention, wherein the system further comprises a signal generator.
- [0039] In accordance with an additional aspect of the present invention, wherein the system further comprises a computer, in communication with the signal analyzer.
- [0040] In accordance with an aspect of the present invention, there is thus provided a method for tissue characterization, comprising:
- [0041] providing a device for tissue characterization, which comprises:
- [0042] a structure;
- [0043] a first mechanism, associated with the structure, configured for exerting a first force on a tissue, for fixing the tissue to the structure, so as to substantially immobilize the tissue; and
- [0044] a second mechanism, associated with the structure, configured for pressing a sensor against an external surface of the immobilized tissue, thereby exerting a second force on the immobilized tissue,
- [0045] wherein at least a component of the first force is in opposition to at least a component of the second force, forcing the immobilized tissue against the sensor, and forcing the sensor against the immobilized tissue, thus bringing about an effective contact between the sensor and the immobilized tissue;
- [0046] fixing the tissue to the structure, thus substantially immobilizing the tissue; and
- [0047] pressing the sensor against the external surface of the immobilized tissue, thereby exerting the second force on the immobilized tissue, wherein at least the component of the first force is in opposition to at least the component of the second force, forcing the immobilized tissue against the sensor, and forcing the sensor against the immobilized tissue, thus bringing about the effective contact between the sensor and the immobilized tissue.
- [0048] In accordance with an aspect of the present invention, there is thus provided a method of tissue characterization, comprising:
- [0049] exerting a first force on a tissue, for fixing the tissue to a structure, so as to substantially immobilize the tissue; and
- [0050] pressing a sensor against an external surface of the immobilized tissue, thereby exerting a second force on the immobilized tissue, wherein at least a component of the first

force is in opposition to at least a component of the second force, forcing the immobilized tissue against the sensor, and forcing the sensor against the immobilized tissue, thus bringing about an effective contact between the sensor and the immobilized tissue.

[0051] Unless otherwise defined, all technical and scientific terms used herein have the same meaning as commonly understood by one of ordinary skill in the art to which this invention belongs. Although methods and materials similar or equivalent to those described herein can be used in the practice or testing of the present invention, suitable methods and materials are described below. In case of conflict, the patent specification, including definitions, will control. In addition, the materials, methods, and examples are illustrative only and not intended to be limiting.

BRIEF DESCRIPTION OF THE DRAWINGS

[0052] The invention is herein described, by way of example only, with reference to the accompanying drawings. With specific reference now to the drawings in detail, it is stressed that the particulars shown are by way of example and for purposes of illustrative discussion of the preferred embodiments of the present invention only, and are presented in the cause of providing what is believed to be the most useful and readily understood description of the principles and conceptual aspects of the invention. In this regard, no attempt is made to show structural details of the invention in more detail than is necessary for a fundamental understanding of the invention, the description taken with the drawings making apparent to those skilled in the art how the several forms of the invention may be embodied in practice.

[0053] In the drawings:

[0054] FIGS. 1A-1E schematically illustrate poor interfaces between a tissue and a sensor;

[0055] FIG. 1F schematically illustrates side cross-sectional views of a device for forming effective sensor-to-tissue contact, according to a preferred embodiment of the present invention;

[0056] FIG. 1G schematically illustrates a force diagram for the tissue-sensor interface, in accordance with the present invention;

[0057] FIG. 1H schematically illustrates an interface of effective sensor-to-tissue contact, according to the present invention;

[0058] FIGS. 2A-2C schematically illustrate the proximal end of a device for forming effective sensor-to-tissue contact, during three time steps in the operation of the device, in accordance with the present invention;

[0059] FIGS. 3A-3C schematically illustrate side and top cross-sectional views of a first mechanism for attaching the device to the tissue surface, according to an embodiment of the present invention;

[0060] FIGS. 4A-4D schematically illustrate side and top cross-sectional views of the first mechanism for attaching the device to the tissue surface, according to another embodiment of the present invention;

[0061] FIGS. 5A-5B schematically illustrate a side cross-sectional view of a second mechanism, for forming effective sensor-to-tissue contact, according to the present invention;

[0062] FIG. 6 schematically illustrates a side cross-sectional view of the proximal end of the device for tissue characterization, showing a second mechanism, for forming effective sensor-to-tissue contact, according to another embodiment of the present invention;

[0063] FIG. 7 schematically illustrates a side cross-sectional view of the proximal end of the device for tissue characterization showing the second mechanism, for forming effective sensor-to-tissue contact, according to yet another embodiment of the present invention;

[0064] FIGS. 8A-8D schematically illustrate manners of controlling the piston travel, according to two alternative embodiments of the present invention;

[0065] FIGS. 9A-9D schematically illustrate various geometries for the proximal ends of the sensor, in accordance with the present invention;

[0066] FIGS. 10A-10D schematically illustrate a prototype of the device for tissue characterization, in accordance with a preferred embodiment of the present invention;

[0067] FIGS. 11A-11D schematically illustrate another prototype of the device for tissue characterization, in accordance with yet another preferred embodiment of the present invention;

[0068] FIG. 12 schematically illustrates an overall system for tissue characterization, in accordance with the present invention; and

[0069] FIGS. 13A-13E schematically illustrate types of sensors for use with the device of the present invention.

DESCRIPTION OF THE PREFERRED EMBODIMENTS

[0070] The present invention is of a device and method for tissue characterization, the device comprising: a structure; a first mechanism, associated with said structure, configured for exerting a first force on a tissue, for fixing the tissue to said structure, so as to substantially immobilize the tissue; and a second mechanism, associated with said structure, configured for pressing a sensor against an external surface of the immobilized tissue, thereby exerting a second force on the immobilized tissue, wherein at least a component of said first force is in opposition to at least a component of said second force, forcing the immobilized tissue against said sensor, and forcing said sensor against the immobilized tissue, bringing about an effective contact between said sensor and the immobilized tissue.

[0071] The sensor may be an optical sensor, an MRI sensor, an RF sensor, a MW sensor, an X-ray sensor, an ultrasound sensor, a temperature sensor, an infrared thermography sensor, a biosensor, a chemical sensor, and a mechanical sensor, or another sensor, as known.

[0072] Before explaining at least one embodiment of the invention in detail, it should be understood that the invention is not limited in its application to the details of construction and the arrangement of the components set forth in the following description or illustrated in the drawings. The invention is capable of other embodiments or of being practiced or carried out in various ways. Also, it is to be understood that the phraseology and terminology employed herein is for the purpose of description and should not be regarded as limiting.

[0073] Reference is now made to FIGS. 1A-1E, which schematically illustrate poor interface contact between a tissue and a sensor.

[0074] FIG. 1A describes a sensor-tissue arrangement 50, and in particular, an interface 45 between a sensor 122 and a tissue 118, along a section 43, of the sensor-tissue arrangement 50. The tissue 118 defines a tissue surface 119.

[0075] FIG. 1B provides a cross-sectional view of the interface 45, showing bubbles 46 of air or fluids, and (or) inclusions 47 of foreign matter, which reduce and otherwise deteriorate the quality of the contact area between the tissue 118 and the sensor 122, along the interface 45.

[0076] FIG. 1C also provides the cross-sectional view of the interface 45, showing that tissue folds 48, possibly with bubbles 46, may also reduce and otherwise deteriorate the quality of the contact area between the tissue 118 and the sensor 122, along the interface 45.

[0077] FIG. 1D provides a view of the interface 45, from the direction of an arrow 11 of FIG. 1A, showing the bubbles 46 and the inclusions 47, reducing an area A of the interface 45.

[0078] Defining an overall contact area, A(interface), as the whole area of the interface 45, and defining bubble and inclusions area, A(bubbles and inclusions), as an area covered by bubbles 46 of air and (or) fluid, and (or) covered by inclusions 47 of foreign matter, we may calculate a contact level, as follows:

$$\text{Contact Level} = \frac{A(\text{interface}) - A(\text{bubbles and inclusions})}{A(\text{interface})}$$

[0079] In this manner, it is possible to quantify the effect of the bubbles 46 and the inclusions 47, and evaluate if the interface 45 is acceptable for tissue characterization, with a given sensor.

[0080] FIG. 1E again provides the cross-sectional view of the interface 45, in reference to irradiative sensors, showing a situation where the external-most surfaces of the tissue 118 and the sensors 122 are slightly apart, by an average distance t, so that in effect, there are three interfaces, 45A, 45B, and 45C, which may operate as three distinct reflective surfaces to radiation 52. The first, 45A, is the edge surface of sensor 122, the second, 45B, is the tissue surface 119, and the third, 45C, is a joint interface of sensor 122 and tissue surface 119, at a point of contact. This effect may be important for radiation of a wavelength λ , for which the average distance t and the radiation wavelength λ are of a same order of magnitude.

[0081] Reference is now made to FIGS. 1F-1H, which schematically illustrate the principles of a device 100, for tissue characterization, with effective sensor-to-tissue contact, in accordance with the present invention.

[0082] FIG. 1F schematically illustrates a cross-sectional view of a device 100, for forming effective sensor-to-tissue contact, to improve tissue characterization, in accordance

with a preferred embodiment of the present invention. Device 100 comprises:

[0083] i. a structure 101;

[0084] ii. a first mechanism 116, associated with structure 101 and configured for exerting a first force on a tissue 118, for fixing tissue 118 to structure 101, so as to substantially immobilize tissue 118; and

[0085] iii. a second mechanism 120, associated with structure 101, configured for pressing a sensor 122 against the tissue surface 119 (FIG. 1A) of the immobilized tissue 118, thereby exerting a second force on immobilized tissue 118,

[0086] wherein a component of the first force is in opposition to a component of the second force, forcing immobilized tissue 118 against sensor 122, and forcing sensor 122 against immobilized tissue 118, bringing about an effective contact between sensor 122 and immobilized tissue 118.

[0087] In accordance with the preferred embodiment, structure 101 includes a first portion 102, forming a distal portion 104, adapted for hand gripping, and a second portion 103, forming a proximal portion 106, having a proximal end 108, with respect to tissue 118. Proximal end 108 has a frame 110, preferably formed as a ring, of an inner diameter 112 and an outer diameter 114. Frame 110 is associated with first mechanism 116, such as suction, designed for attaching tissue 118 to frame 110.

[0088] A duct system 142 provides air-pressure communication between a pump 268 (shown hereinbelow in FIG. 12), and frame 110, for creating a negative pressure required to attach tissue 118 to frame 110, by suction. A vacuum outlet 105 is adapted for connecting to a pump.

[0089] Additionally, device 100 includes second mechanism 120, such as a piston 120, within second portion 103. Piston 120 includes sensor 122, at a proximal end 126.

[0090] Piston 120 is selectively configured for deployed and retracted positions. For deployment, it slides proximally and presses against tissue 118, while it is held fast by first mechanism 116, thus achieving effective sensor-to-tissue contact between sensor 122 and tissue 118.

[0091] FIG. 1G schematically illustrates a balance of force diagram of first and second mechanisms 116 and 120. In essence, first mechanism 116 imposes a force F_1 , for pressing tissue 118 against frame 110 of device 100, at proximal end 108, while second mechanism 120 imposes a force F_2 , which is substantially opposite in direction to F_1 , for pressing sensor 122 against tissue 118. In other words, tissue 118 is pressed against sensor 120 and sensor 120 is pressed against tissue 118.

[0092] Each mechanism provides opposition to the other. The force F_1 ensures that tissue 118 will not move away from sensor 122, under the force F_2 , and the force F_1 ensures that sensor 122 will not move away from tissue 118, under the force F_1 . Operating together, first and second mechanisms 116 and 120 ensure that effective sensor-to-tissue contact is formed, at interface 45.

[0093] Alternatively, first mechanism 116 imposes a force F_1 , a component of which presses tissue 118 against frame 110 of device 100, at proximal end 108, while second mechanism 120 imposes a force F_2 , a component of which

presses sensor 122 against tissue 118, so that components of each mechanism provide opposition to the other.

[0094] Thus, either the forces F_1 and F_2 , or components thereof, ensure that tissue 118 will not move away from sensor 122 and that sensor 122 will not move away from tissue 118, so that effective sensor-to-tissue contact is formed, at interface 45.

[0095] Reference is now made to FIG. 1H, which schematically illustrates effective sensor-to-tissue contact, as a consequence of the balance of force diagram of FIG. 1G, in accordance with the present invention.

[0096] As seen in FIG. 1H, the interface 45 is substantially free of bubbles 46, foreign inclusions 47, and tissue folds 48, leading to effective contact, between the tissue 118 and the sensor 122, the effective contact being defined as a contact level of at least 95%, preferably, at least 98%, and more preferably, at least 99.8%.

[0097] Additionally, in accordance with embodiments of the present invention, which relate to sensors, operating with a wavelength λ , the effective contact may be further defined as a contact, for which the relationship between the wavelength λ and an average distance t_1 , the average distance after achieving effective contact, (see FIG. 1H) is such that $t_1 < \lambda/3$, and preferably, $t_1 < \lambda/10$, and more preferably, $t_1 < \lambda/100$.

[0098] Additionally or alternatively, the effective contact may be defined in absolute terms. Accordingly, the average distance t_1 is less than 500 Angstroms, preferably the average distance t_1 is less than 50 Angstroms, and more preferably, the average distance t_1 is less than 5 Angstroms.

[0099] Reference is now made to FIGS. 2A-2C, which schematically illustrate the operation of proximal portion 106 of the device 100.

[0100] As seen in FIG. 2A, illustrating a first step, device 100, which is preferably a hand-held device, is physically brought proximally to tissue 118, for example, by hand.

[0101] As seen in FIG. 2B, illustrating a second step, tissue 118 is attached to device 100, via first mechanism 116, for example, by suction, along orifices 140.

[0102] As seen in FIG. 2C, illustrating a third step, second mechanism 120 is deployed, for pressing sensor 122 against tissue surface 119, forming substantially the single interface 45.

[0103] At this point, effective sensor-to-tissue contact has been formed, substantially, as described in FIG. 1F, and tissue characterization may take place, by the sensor 122.

[0104] Reference is now made to FIGS. 3A-3C, illustrating side and top cross sectional views of first mechanism 116 for attaching device 100 to tissue surface 119 according to the preferred embodiment of the present invention.

[0105] Frame 110 at proximal end 108 is preferably shaped as two concentric circles, of an inner diameter 112 and an outer diameter 114. Furthermore, inner diameter 112 is configured to allow piston 120 to advance towards tissue surface 119 through it so that proximal end 126 of piston 120 protrudes beyond frame 110, so as to press against tissue 118 which is attached to frame 110.

[0106] Additionally, frame 110 is provided with an at least two orifices 140, preferably arranged between circumferences 112 and 114. Additionally, more orifices, for example, eight orifices may be used, as shown in FIG. 3B. Furthermore, suction is employed through the orifices 140 for attaching tissue 118 to frame 110 to tissue surface 119 (FIG. 1A). Moreover the suction is employed via duct system 142.

[0107] In FIG. 3C a flexible skirt 144 is added to outer diameter 114 of frame 110 for providing improved suction when attaching tissue 118 to proximal portion 106. Preferably, flexible skirt 144 is made of a resilient material, for example, natural or synthetic rubber.

[0108] Reference is now made to FIGS. 4A-4D, illustrating side and top cross sectional views of the first mechanism 116 for attaching the device to the tissue surface according to another embodiment of the present invention using a gripping device 150.

[0109] According to the embodiment described in FIGS. 4A-D, gripping device 150 is positioned on frame 110. Additionally, gripping device 150 comprises an at least two claws 152 configured to be in either a released state (as shown in FIG. 4C) or a gripping state (as shown in FIG. 4D). Preferably, at least two claws 152 are arranged on frame 110 (eight claws are shown in FIG. 4B). Prior to gripping tissue 118, proximal portion 106 is positioned close to tissue surface 119 with at least two claws 152 being in a retracted position. The claws are then brought to a gripping state, thus attaching tissue 118 to proximal portion 106 and completing the first stage of creating effective sensor-to-tissue contact between sensor 122 of device 100 and tissue surface 119.

[0110] Reference is now made to FIGS. 5A-5B schematically illustrating a side cross sectional view of the second mechanism 120, for forming effective sensor-to-tissue contact, according to one embodiment of the present invention.

[0111] Second mechanism 120 is preferably a piston 120 having a tissue characterizing sensor 122 at proximal end 126. Piston 120 is configured to slide smoothly from a retracted position (shown in FIG. 5A) to a deployed position (shown in FIG. 5B) in which effective contact between tissue 118 and tissue characterizing sensor 122 is established. Advancing piston 120 towards tissue 118 may be controlled by at least one spring 160. Furthermore, advancing piston 120 towards tissue 118 may be actuated using a switch 162. Preferably, a surface 164 of proximal end 126 of piston 120 is highly polished, for creating the effective contact with tissue 118.

[0112] Reference is now made to FIG. 6, schematically illustrating a side cross sectional view of proximal portion 106 of device 100 for tissue characterization, according to another embodiment of the present invention.

[0113] According to the present embodiment, spring 160 is contained within a spring tunnel 170, which is connected to duct system 142. Therefore, piston 120 is actuated by the suction created in spring tunnel 170, responsive to the partial pressure in duct system 142, when orifices 140 are closed, as first mechanism 116 attaches tissue 118 to device 100 at proximal end 108.

[0114] Reference is now made to FIG. 7, schematically illustrating a side cross sectional view of proximal portion

106 of device 100 for tissue characterization, according to yet another embodiment of the present invention.

[0115] The present embodiment also illustrates a 172 coordinate system. Piston 120 slides towards tissue 118 along a Z axis, perpendicular to frame 110, while vibrating in an XY-plane, perpendicular to Z axis. The vibration motion in XY-plane allows for a gliding motion against tissue 118, which in effect removes, as if by sweeping, any foreign matter, or entrapped gases or liquids, from the interface 45 (FIG. 2C).

[0116] Reference is now made to FIGS. 8A-8D, which schematically illustrate manners of controlling the travel of piston 120, according to two alternative embodiments of the present invention

[0117] FIGS. 8A and 8B schematically illustrate piston 120 in retracted and deployed positions, respectively, according to a first embodiment. Piston 120 has a fixed travel d, shown as 180, wherein the construction of proximal portion 106 operates as a stop, to ensure the fixed travel. Alternatively, the fixed travel is reached when spring 160 is compressed to its maximum value. Preferably, distance d is between about 1 mm and about 50 mm.

[0118] FIGS. 8C and 8D schematically illustrate piston 120 in retracted and deployed positions, respectively, according to a second embodiment. The advancement of piston 120 and of sensor 122 is such that a force F₃, exerted on piston 120, in the -z direction is exactly balanced by the force, which the attached tissue 118 imposes on sensor 122, in the +z direction, and by the force contracted spring 160 imposes on piston 120 in the +z direction.

[0119] Reference is now made to FIGS. 9A-9D, which schematically illustrate various geometries for the proximal ends 126 of the sensor 122, in accordance with the present invention.

[0120] FIG. 9A provides the reference coordinate system 172.

[0121] FIG. 9B schematically illustrates a roller-shaped sensor 122, and its polished surface 164, at proximal end 126.

[0122] FIG. 9C schematically illustrates a dome-shaped sensor 122, and its polished surface 164, at proximal end 126.

[0123] FIG. 9D schematically illustrates a cube-shaped sensor 122, and its polished surface 164, at proximal end 126.

[0124] It will be appreciated that other shapes are also possible.

[0125] Reference is now made to FIGS. 10A-10D, schematically illustrating a prototype of device 100, for tissue characterization, in accordance with a preferred embodiment of the present invention. Prototype device 100 illustrated here is generally applied when perpendicular to tissue 118, so that its length axis L is along the Z axis, while tissue surface 119 (FIGS. 2A-2C) is generally in the X-Y plane. Device 100 preferably has a length of between about 50 mm and about 300 mm, and a diameter of between about 10 mm and about 150 mm. It will be appreciated that other dimensions are similarly possible. Structure 101 of device 100 is preferably made of a rigid material, for example, a rigid

plastic, ceramics, wood, or the like. Vacuum outlet **105** is adapted for connecting to a pump.

[0126] Reference is now made to FIGS. **11A-11D**, schematically illustrating another prototype of the device **100**, for tissue characterization, in accordance with yet another preferred embodiment of the present invention. Prototype device **100** illustrated here is shaped as an arm **300** having housing **103** at a proximal end **302** of arm **300**. Prototype device **100** illustrated in FIGS. **11A-11D** is generally applied when parallel to tissue **118**, so that its length axis **L** and the tissue surface **119** are the X-Y plane and sensor **122** moves in the Z plane. Preferably, flexible skirt **144** is provided at proximal end of housing **103** for assisting in attaching tissue **118** to frame **110**.

[0127] Reference is now made to FIG. **12**, schematically illustrating an overall system for tissue characterization, in accordance with the present invention.

[0128] System **260** includes device **100**, having sensor **122**.

[0129] A signal generator **272** provides sensor **122** with a signal and a signal analyzer **270** receives and analyzes signals from sensor **122**. It will be appreciated that signal generator **272** and signal analyzer **270** may be integrated into a single unit.

[0130] For example, where the sensor **122** is a dielectric-property sensor, constructed essentially as coaxial cable, units **270** and **272** may include, for example, an impedance analyzing external unit, such as Agilent 4396A, and a test fixture connected via a coaxial cable to the impedance analyzing external unit. The sensors may be battery operated or associated with power supply units.

[0131] It will be appreciated that units **270** and **272** will complement the specific sensor **122**. For example, where sensor **122** is an optical sensor, unit **272** may be a light emitting diode or a laser, and unit **270** may be an optical analyzer or a CCD.

[0132] A computer **265**, which may be a personal computer, a laptop, a palmtop, a microcomputer, or another computer, as known, may also be used for additional data analysis. Preferably, computer **265** includes a user interface, for example, a keyboard **280**, or knobs, and may further include storage systems, such as a read and write drive **282**, a USB port **284**, and a display screen **290**.

[0133] Reference is now made to FIGS. **13A-13E**, schematically illustrating cross sectional side views of piston **120** containing sensor **122**. The illustrations show a variety of sensors for characterizing the tissue after the tissue surface is brought to effective contact with the sensor, according to preferred embodiments of the present invention.

[0134] Sensor **122** may be a dielectric-property sensor, an optical sensor, an MRI sensor, an RF sensor, a MW sensor, an X-ray sensor, an ultrasound sensor, a biosensor, a chemical sensor, a mechanical sensor, a temperature sensor, an infrared thermography sensor, or another sensor, as known.

[0135] FIGS. **13A** and **13B** illustrate a side cross-sectional view and a view from proximal end **126**, respectively, of piston **120** and sensor **122**. According to the present embodiment, sensor **122** is a dielectric-property sensor **200**, for measuring the dielectric properties of tissue **118**, for

example, as taught by commonly owned US Patent U.S. Pat. No. 6,813,515 and commonly owned PCT publication WO 03/060462, both of whose disclosures are incorporated herein by reference. By comparing the results with known tissue dielectric properties, or by evaluating generated pulses with those reflected from the tissue, the characteristics of tissue **118** can be determined. Furthermore, dielectric-property sensor **200** may be constructed as a coaxial cable **202**, having an inner electrode **204** and an outer electrode **206**, separated by a layer of insulation. Outer electrode **206** may be grounded. Preferably, coaxial cable **202** is located within piston **120**. Signals from dielectric-property sensor **200** are transferred for analysis through a transmission line **208** to a computerized system **260**, described hereinbelow in conjunction with FIG. **12**.

[0136] Preferably, inner electrode **204** has a diameter **212** of between about 0.2 and 1.5 mm and outer electrode **206** has an inner diameter **210** of between about 3.0 and 10.0 mm, and is about 0.5 mm thick. It will be appreciated that other dimensions, which may be larger or smaller, may similarly be used.

[0137] Additionally, outer electrode **206** may be covered with an insulating sheath **214** made of an insulating material, for example, Teflon. The dielectric-property sensor **200** may be encased in a filler material **216**, for example epoxy, which may be formed as a plug that fits into piston **120**.

[0138] FIG. **13C** illustrates piston **120** comprising sensor **122** formed as an RF or MW horn antenna **230** mounted on piston **120**, in accordance with still another embodiment of the present invention. RF or MW horn antenna **230** is associated with an RF/MW transmission line or wave guide **232**, while units **270** and **272** (FIG. **12**) are RF/MW generation, collection and analysis units. The present embodiment relies on RF microwave characterization by the generation of propagating radiation in the RF microwave region of the electromagnetic spectrum, towards the tissue, and measuring its reflection. The radiation is usually transmitted and received by an antenna, for example the horn antenna **230**. The tissue characterization is done by analyzing the amplitude and phase difference between the original waves to the reflected wave.

[0139] FIG. **13D** illustrates piston **120** comprising sensor **122** formed as an optical sensor **240** mounted on piston **120**, in accordance with yet another embodiment of the present invention. An optical signal is generated in an external unit, such as unit **270** (FIG. **12**) and transmitted via an optical fiber **242** to tissue **118**. The reflection of the light is then received in a dedicated module inside the optical unit. The optical energy is usually transmitted to and from tissue **118** via a lens **244**.

[0140] The details of optical signal generation, receiving and analyzing depend on the specific optical method that is chosen. For example, for reflection spectroscopy, tissue characterization relies on measuring the relative amplitude and phase of the reflected light versus the generated light. An example for the reflection spectroscopy method is described in commonly owned U.S. patent application Ser. No. 10/298,196, whose disclosure is incorporated herein by reference. It will be appreciated that other methods may be used, as known.

[0141] Alternatively, auto fluorescence may be used, for measuring emitted radiation, from the tissue, at different a

wavelength than that originally transmitted. The emitted radiation occurs in response to excitation by impinging radiation, and may be used for tissue characterization, for example, as used by Xillix Technologies Corp., and described in http://www.xillix.com/index_home.cfm. It will be appreciated that other methods may be used, as known.

[0142] FIG. 13E illustrates piston 120 comprising sensor 122 being an MRI sensor 250 mounted on piston 120, in accordance with yet another embodiment of the present invention. MRI sensor 250 has a permanent magnet 252, enclosed in an RF coil 254, for example, as taught in commonly owned US Patent Application Publication No. 2005/0021019 to Hashimshony et al., entitled "Method and apparatus for examining substance, particularly tissue, to characterize its type," whose disclosure is incorporated herein by reference, and in U.S. Pat. No. 5,572,132, to Pulyer, et al., entitled, "MRI probe for external imaging," whose disclosure is incorporated herein by reference.

[0143] In accordance with the present invention, tissue characterization may be performed by various techniques, including any one of the following nonexhaustive list, or by another technique.

[0144] Tissue characterization by ultrasonography: Ultrasonography is a medical imaging technique, using high frequency sound waves in the range of about 1 to 20 MHz and their echoes. The sound waves travel in the body and are reflected by interfaces between different types of tissues, such as between a healthy tissue and a denser cancerous tissue, or between a portion of a soft tissue and a bone. The ultrasound probe receives the reflected sound waves and the associated instrumentation calculates the distances from the probe to the reflecting boundaries.

[0145] The ultrasound probe includes a piezoelectric crystal, which produces an electric signal in response to a pressure pulse. The shape of the probe determines its field of view, and the frequency of the emitted sound determines the minimal detectable object size. Generally, the probes are designed to move across the surface of the body. However, some probes are designed to be inserted through body lumens, such as the vagina or the rectum, so as to get closer to the organ being examined.

[0146] Before the early 1970's ultrasound imaging systems were able to record only the strong echoes arising from the outlines of an organ, but not the low-level echoes of the internal structure. In 1972 a refined imaging mode was introduced called gray-scale display, in which the internal texture of many organs became visible. In consequence, ultrasound imaging became a useful tool for imaging tumors, for example, in the liver.

[0147] A development of recent years is a 3D ultrasound imaging, in which, several two-dimensional images are acquired by moving the probes across the body surface or by rotating probes, inserted into body lumens. The two-dimensional scans are then combined by specialized computer software to form 3D images.

[0148] In multiple-element probes, each element has a dedicated electric circuit, so that the beam can be "steered" by changing the timing in which each element sends out a pulse. By sequentially stimulating each element, the beams can be rapidly steered from the left to right, to produce a two-dimensional cross sectional image. Additionally, trans-

ducer-pulse controls allow the operator to set and change the frequency and duration of the ultrasound pulses, as well as the scan mode of the machine. A probe formed of array transducers has the ability to be steered as well as focused.

[0149] Contrast agents may be used in conjunction with ultrasound imaging, for example as taught by U.S. Pat. No. 6,280,704, to Schutt, et al., entitled, "Ultrasonic imaging system utilizing a long-persistence contrast agent," whose disclosure is incorporated herein by reference.

[0150] Tissue characterization by its dielectric properties: There are several known techniques for local tissue characterization by the tissue's electromagnetic properties.

[0151] Commonly owned U.S. Pat. No. 6,813,515, to Hashimshony, entitled, "Method and system for examining tissue according to the dielectric properties thereof," whose disclosure is incorporated herein by reference, describes a method and system for examining tissue in order to differentiate it from other tissue, according to the dielectric properties of the examined tissue. The method includes applying an electrical pulse to the tissue to be examined via a probe formed with an open cavity such that the probe generates an electrical fringe field in examined tissue within the cavity and produces a reflected electrical pulse therefrom with negligible radiation penetrating into other tissues or biological bodies near the examined tissue; detecting the reflected electrical pulse; and comparing electrical characteristics of the reflected electrical pulse with respect to the applied electrical pulse to provide an indication of the dielectric properties of the examined tissue.

[0152] Furthermore, commonly owned U.S. Provisional Application No. 60/641,081, entitled, "Device and Method for Tissue Characterization in a Body Lumen, by an Endoscopic Electromagnetic Probe," whose disclosure is incorporated herein by reference, discloses a device and method for tissue characterization in a body lumen, for the detection of abnormalities, using an electromagnetic probe, mounted on an endoscope. The endoscope may be designed for insertion in a body lumen, selected from the group consisting of an oral cavity, a gastrointestinal tract, a rectum, a colon, bronchi, a vagina, a cervix, a urinary tract, and blood vessels. Additionally, it may be designed for insertion in a tricar valve.

[0153] Additionally, commonly owned U.S. Provisional Application No. 60/665,842, entitled, "Electromagnetic Sensors for tissue Characterization," whose disclosure is incorporated herein by reference, discloses a sensor, comprising: a resonating element, formed as a conductive structure, configured to be placed proximally to an edge of a tissue for characterization, without penetrating the tissue, and having a diameter-equivalent D , which defines a cross-sectional area of the resonating element, on a plane substantially parallel with the edge; and at least one conductive lead, for providing communication with an external system, wherein the resonating element is configured to resonate at a free-air wavelength range of between about λ and about 10λ , wherein λ is at least about ten times the diameter-equivalent D , and wherein upon receiving a signal in the range of between about λ and about 10λ , the sensor is configured to induce electric and magnetic fields, in a near zone, in the tissue, the near zone being a hemisphere having a diameter of substantially D , beginning with the edge, while causing negligible radiation in a far zone, so that the tissue,

in the near zone, effectively functions as part of the resonating element, varying a resonating response to the sensor, and so the tissue, in the near zone, is thereby characterized by its electromagnetic properties, by the resonating response to the sensor.

[0154] Tissue Characterization by electrical impedance imaging: Electrical impedance imaging relates to measuring the impedance between a point on the surface of the skin and some reference point on the body of a patient. Sometimes, a multi-element probe, formed as a sheet having an array of electrical contacts, is used for obtaining a two-dimensional impedance map of the tissue, for example, the breast. The two-dimensional impedance map may be used, possibly in conjunction with other data, such as mammography, for the detection of cancer.

[0155] Rajshekhar, V. ("Continuous impedance monitoring during CT-guided stereotactic surgery: relative value in cystic and solid lesions," Rajshekhar, V., *British Journal of Neurosurgery*, 1992, 6, 439-444) describes using an impedance probe with a single electrode to measure the impedance characteristics of lesions. The objective of the study was to use the measurements made in the lesions to determine the extent of the lesions and to localize the lesions more accurately. The probe was guided to the tumor by CT and four measurements were made within the lesion as the probe passed through the lesion. A biopsy of the lesion was performed using the outer sheath of the probe as a guide to position, after the probe itself was withdrawn.

[0156] U.S. Pat. No. 4,458,694, to Sollish, et al., entitled, "Apparatus and method for detection of tumors in tissue," whose disclosure is incorporated herein by reference, relates to an apparatus for detecting tumors in human breast, based on the dielectric constants of localized regions of the breast tissue. The apparatus includes a probe, including a plurality of elements. The apparatus further includes means for applying an AC signal to the tissue, means for sensing dielectric properties at each of the probe elements at different times, and signal processing circuitry, coupled to the sensing means, for comparing the dielectric properties sensed at the different times. The apparatus thus provides an output of the dielectric constants of localized regions of breast tissue associated with the probe.

[0157] Similarly, U.S. Pat. No. 4,291,708 to Frei, et al., entitled, "Apparatus and method for detection of tumors in tissue," whose disclosure is incorporated herein by reference, relates to apparatus for detecting tumors in human breast tissue, by the dielectric constants of a plurality of localized regions of human breast tissue.

[0158] U.S. Pat. Nos. 6,308,097, 6,055,452 and 5,810,742, to Pearlman, A. L., entitled, "Tissue characterization based on impedance images and on impedance measurements," whose disclosures are incorporated herein by reference, describe apparatus for aiding in the identification of tissue type for an anomalous tissue in an impedance image. The device comprises: means for providing a polychromatic emittance map of a portion of the body; means for determining a plurality of polychromatic measures from one or both of a portion of the body; and a display of an indication based on said plurality of polychromatic measures.

[0159] Tissue Characterization by Optical Fluorescence Spectroscopy: When a sample of large molecules is irradi-

ated, for example, by laser light, it will absorb radiation, and various levels will be excited. Some of the excited states will return back substantially to the previous state, by elastic scattering, and some energy will be lost in internal conversion, collisions and other loss mechanisms. However, some excited states will create fluorescent radiation, which, due to the distribution of states, will give a characteristic wavelength distribution.

[0160] Some tumor-marking agents give well-structured fluorescence spectra, when irradiated by laser light. In particular, hematoporphyrin derivatives (HPD), give a well-structured fluorescence spectrum, when excited in the Soret band around 405 nm. The fluorescence spectrum shows typical peaks at about 630 and 690 nm, superimposed in practice on more unstructured tissue autofluorescence. Other useful tumor-marking agents are dihematoporphyrin ether/ester (DHE), hematoporphyrin (HP), polyhematoporphyrin ester (PHE), and tetrasulfonated phthalocyanine (TSPC), when irradiated at 337 nm (N₂ laser).

[0161] U.S. Pat. No. 5,115,137, to Andersson-Engels, et al., entitled, "Diagnosis by means of fluorescent light emission from tissue," whose disclosure is incorporated herein by reference, relates to improved detection of properties of tissue by means of induced fluorescence of large molecules. The tissue character may then be evaluated from the observed large-molecule spectra. According to U.S. Pat. No. 5,115,137, the spectrum for tonsil cancer is clearly different from normal mucosa, due to endogenous porphyrins.

[0162] U.S. Pat. No. 6,258,576, to Richards-Kortum, et al., entitled, "Diagnostic method and apparatus for cervical squamous intraepithelial lesions in vitro and in vivo using fluorescence spectroscopy," whose disclosure is incorporated herein by reference, relates to the use of multiple illumination wavelengths in fluorescence spectroscopy for the diagnosis of cancer and precancer, for example, in the cervix. In this manner, it has been possible to (i) differentiate normal or inflamed tissue from squamous intraepithelial lesions (SILs) and (ii) differentiate high grade SILs from non-high grade SILs. The detection may be performed in vitro or in vivo. Multivariate statistical analysis has been employed to reduce the number of fluorescence excitation-emission wavelength pairs needed to re-develop algorithms that demonstrate a minimum decrease in classification accuracy. For example, the method of the aforementioned patent may comprise illuminating a tissue sample with electromagnetic radiation wavelengths of about 337 nm, 380 nm and 460 nm, to produce fluorescence; detecting a plurality of discrete emission wavelengths from the fluorescence; and calculating from the emission wavelengths a probability that the tissue sample belongs in particular tissue classification.

[0163] Commonly owned U.S. Patent Application Publication No. 2003/01383786, to Hashimshony, entitled, "Method and apparatus for examining tissue for predefined target cells, particularly cancerous cells, and a probe useful for such method and apparatus," whose disclosure is incorporated herein by reference, teaches a method apparatus and probe for examining tissue and characterizing its type according to measured changes in optical characteristics of the examined tissue. In a preferred embodiment of this method the tissue to be examined is subject to a contrast agent containing small particles of a physical element conjugated with a biological carrier selectively bindable to the

target cells. Additionally, energy pulses are applied to the examined tissue, and the changes in impedance and/or the optical characteristics produced by the applied energy pulses are detected and utilized for determining the presence of the target cells in the examined tissue. Furthermore, in a preferred embodiment, the applied energy pulses include laser pulses, and the physical element conjugated with a biological carrier is a light-sensitive semiconductor having an impedance which substantially decrease in the presence of light. Moreover, the same probe used for detecting the targeted cells, may also be used for destroying the cells so targeted.

[0164] Tissue Characterization by Optical reflectance spectroscopy: The application optical reflectance spectroscopy for tissue characterization is described, for example, in <http://www.sbsp-limb.nichd.nih.gov/html/spectroscopy.html>, downloaded on Mar. 15, 2005, disclosing an optical reflectance spectroscopy (ORS) device for measuring the thickness of the epithelial layer, and an evaluation technique based on oblique angle reflectance spectroscopy, that allows assessment of the scattering and absorption properties of the epithelium and stroma, thus providing information on chronic oral epithelial tissue inflammation, which is considered a potential diagnostic precursor to oral cancer.

[0165] Additionally, Tomatis, A., et al, studied reflectance images of 43 pigmented lesions of the skin (18 melanomas, 17 common melanocytic naevi and eight dysplastic naevi). Reflectance images were acquired by a telespectrophotometric system and were analyzed in the spectral range from 420 to 1040 nm, to discriminate melanoma from benign melanocytic entities. Different evaluations were carried out considering the whole spectrum, the visible and the near infrared. A total of 33 (76.7%) lesions were correctly diagnosed by the telespectrophotometric system, compared with 35 (81.4%) correct clinical diagnoses. Reflectance in the infrared band appears diagnostically relevant.

[0166] Tissue Characterization by Magnetic Resonance Imaging (MRI): Magnetic resonance imaging is based on the absorption and emission of energy in the radio frequency range of the electromagnetic spectrum, by nuclei having unpaired spins.

[0167] Conventional MRI is a large-apparatus, for whole body imaging, having:

[0168] i. a primary magnet, which produces the B_0 field for the imaging procedure;

[0169] ii. gradient coils for producing a gradient in B_0 ;

[0170] iii. an RF coil, for producing the B_1 magnetic field, necessary to rotate the spins by 90° or 180° and for detecting the MRI signal; and

[0171] iv. a computer, for controlling the components of the MRI imager.

[0172] Generally, the magnet is a large horizontal bore superconducting magnet, which provides a homogeneous magnetic field in an internal region within the magnet. A patient or object to be imaged is usually positioned in the homogeneous field region located in the central air gap for imaging. A typical gradient coil system comprises an anti-Helmholtz type of coil. These are two parallel ring shaped coils, around the z axis. Current in each of the two coils flows in opposite directions creating a magnetic field gradient between the two coils.

[0173] The RF coil creates a B_1 field, which rotates the net magnetization in a pulse sequence. The RF coils may be: 1) transmit and receive coils, 2) receive only coils, and 3) transmit only coils.

[0174] As described hereinabove, the MRI relies on a magnetic field in an internal region within the magnet. As such, it is unsuitable as a handheld probe or an endoscopic probe, because the tissue to be imaged has to be in the internal region of the imager,

[0175] However, U.S. Pat. No. 5,572,132, to Pulyer, et al., entitled, "MRI probe for external imaging," whose disclosure is incorporated herein by reference, describes an MRI spectroscopic probe having an external background magnetic field B_0 (as opposed to the internal background magnetic field of the large horizontal bore superconducting magnet.). Thus, an MRI catheter for endoscopical imaging of tissue of the artery wall, rectum, urinal tract, intestine, esophagus, nasal passages, vagina and other biomedical applications may be constructed. The probe comprises (i) a miniature primary magnet having a longitudinal axis and an external surface extending in the axial direction, and (ii) a RF coil surrounding and proximal to said surface. The primary magnet is structured and configured to provide a symmetrical, preferably cylindrically shaped, homogeneous field region external to the surface of the magnet. The RF coil receives NMR signals from excited nuclei. For imaging, one or more gradient coils are provided to spatially encode the nuclear spins of nuclei excited by an RF coil, which may be the same coil used for receiving NMR signals or another RF coil.

[0176] Additionally, commonly owned US Patent Application Publication No. 2005/0021019 to Hashimshony et al., entitled "Method and apparatus for examining substance, particularly tissue, to characterize its type," whose disclosure is incorporated herein by reference, describes a method and apparatus for examining a substance volume to characterize its type, by: applying a polarizing magnetic field through the examined substance: applying RF pulses locally to the examined substance volume such as to invoke electrical impedance (EI) responses signals corresponding to the electrical impedance of the substance, and magnetic resonance (MR) responses signals corresponding to the MR properties of the substance; detecting the EI and MR response signals; and utilizing the detected response signals for characterizing the examined substance volume type.

[0177] Contrast agents may be used in conjunction with MRI. For example, U.S. Pat. No. 6,315,981 to Unger, entitled, "Gas filled microspheres as magnetic resonance imaging contrast agents," whose disclosure is incorporated herein by reference, describes the use of gas filled microspheres as contrast agents for MRI.

[0178] Additionally, U.S. Pat. No. 6,747,454, to Belt, entitled, "Array of coils for use in imaging the vasculature of a patient," whose disclosure is incorporated herein by reference, describes an array of coils, configured for use in imaging the vasculature of a patient.

[0179] Furthermore, U.S. Pat. No. 6,677,755, to Belt, et al., "Circuit for selectively enabling and disabling coils of a multi-coil array," whose disclosure is incorporated herein by reference, describes a circuit, used to selectively enable and disable n-coils. The circuit includes n-drivers powered by a

current source. Each n-driver includes a pair of FETs disposed such that a gate of one FET is connected to a gate of the other FET to form a common gate node thereat. The n-drivers are disposed in a totem-pole configuration. The one FET of a first of the n-drivers has (A) a drain linked to a ground and to an end of a first of the n-coils and (B) a source linked to a drain of the one FET of a second of the n-drivers and to an end of a second of the n-coils. The other FET of the first of the n-drivers has (A) a source linked to an opposite end of the first of the n-coils and (B) a drain linked to the end of the second of the n-coils and to the source of the one FET of the first of the n-drivers. The one FET of the second of the n-drivers also has a source linked to a drain of the one FET of a next of the n-drivers and to an end of a next of the n-coils. The other FET of the second of the n-drivers also has (A) a source linked to an opposite end of the second of the n-coils and (B) a drain linked to the end of the next of the n-coils and to the source of the one FET of the second of the n-drivers. This continues until the one FET and the other FET of an nth of the n-drivers are likewise disposed in the totem-pole configuration of the n-drivers, with a source and a drain of the one FET and the other FET, respectively, of the nth of the n-drivers being connected to the current source. Each of the n-drivers is used to operate a corresponding one of the n-coils by being responsive at its common gate node (i) a coil disable signal by activating the one FET thereof and deactivating the other FET thereof thereby not only drawing current away from and thus disabling the corresponding coil but also allowing the current to flow through the one FET and thus be available as a source of current to a successive one of the n-drivers and (ii) a coil enable signal by deactivating the one FET thereof and activating the other FET thereof thereby allowing the current not only to flow serially through the corresponding coil and the other FET thus enabling the corresponding coil but also to be available as a source of current to the successive one of the n-drivers.

[0180] Tissue Characterization by Temperature Imaging: Temperature Imaging for locating and detecting neoplastic tissue has been known, since the 1950's, when it was discovered that the surface temperature of skin in the area of a malignant tumor exhibited a higher temperature than that expected of healthy tissue. Thus, by measuring body skin temperatures, it became possible to screen for the existence of abnormal body activity such as cancerous tumor growth. With the development of liquid crystals and methods of forming temperature responsive chemical substrates, contact thermometry became a reality along with its use in medical applications. Devices employing contact thermometry could sense and display temperature changes through indicators, which changed colors, either permanently or temporarily, when placed in direct physical contact with a surface such as skin, reflecting a temperature at or near the point of contact. An abnormal reading would alert a user to the need for closer, more detailed examination of the region in question. However, the art in this area has been directed primarily at sensing and displaying temperatures on exterior skin surfaces.

[0181] U.S. Pat. No. 3,830,224, to Vanzetti et al., whose disclosure is incorporated herein by reference, disclosed the placement of temperature responsive, color changing liquid crystals at various points in a brassiere for the purpose of detecting the existence of breast cancer.

[0182] U.S. Pat. No. RE 32,000, to Sagi, entitled, "Device for Use in Early Detection of Breast Cancer," whose disclosure is incorporated herein by reference, disclosed a device comprising a flexible, heat-conductive web, preferably in the form of a disc-shaped patch having an adhesive layer on one side thereof and a peelable layer removably secured thereto by said adhesive layer. On the other side thereof, the device comprises an array of spaced-apart indicators, each of said indicators comprising a dye or a pigment and a temperature sensitive substance (crystalline organic chemical) which melts at a relatively precise temperature which is approximately 0.5.degree. F. different from the adjacent indicator. As many indicators are used as are necessary to cover the desired temperature range. The device is incorporated into the breast-receiving cups of a brassiere and mirror image quadrants of the two breasts are scanned and the device is visually examined to determine the number of indicators which have displayed a change in color, thus apprising the person of the existence of abnormality in the mammary tissue.

[0183] U.S. Pat. No. 6,135,968, to Brounstein, entitled, "Differential temperature measuring device and method", whose disclosure is incorporated herein by reference, describes a device and method for sensing temperatures at internal body locations non-surgically accessible only through body orifices. The device is particularly useful in medical applications such as screening for cancer and other abnormal biological activity signaled by an increase in temperature at a selected site. As applied to prostate examinations, the device is temporarily, adhesively affixed to a user's fingertip or to a mechanical probe. In the preferred embodiment, the device includes two temperature-sensing elements, which may include a plurality of chemical indicators. Each indicator changes color in response to detection of a predetermined particular temperature. When properly aligned and installed, the first element is located on the palmar surface of the fingertip while the second element is located on the dorsal surface of the fingertip. After an examination glove has been donned over the fingertip carrying the device, a prostate examination is performed during which the first element is brought into constant but brief contact with the prostate region and the second element is similarly, simultaneously brought into contact with a dermal surface opposing the prostate region. Upon withdrawal of the fingertip from the rectum and removal of the glove, the two temperature sensing elements may be visually examined in order to determine the temperatures detected by each one. A significant difference in observed temperatures indicates the possibility of abnormal biological activity and the need for further diagnostic or medical procedures.

[0184] Tissue Characterization using Biosensors: Biosensors may be of catalytic type that integrated enzymes, cellular organelles, tissues or whole microorganisms with transducers that convert a biological response into a digital electronic signal. The principal transducers used are electrochemical, optical, or thermometric. Biosensors may also be of affinity type. Affinity biosensors deliver information about the binding of antibodies to antigens, cell receptors to their ligands, and DNA and RNA to nucleic acid with a complementary sequence. Still, additional types are fully integrated biochip devices that perform as micro bio-reactors. All types can be used in high-density arrays of bio-molecular sensors.

[0185] Some of these sensors are further discussed in:

[0186] (i) Enzyme and Microbial Biosensors: Techniques and Protocols. Ed. A. Mulchandani & K. R. Rogers (Humana Press, 1998);

[0187] (ii) Affinity Biosensors: Techniques and Protocols. Ed. A. Mulchandani & K. R. Rogers (Humana Press, 1998);

[0188] (iii) Journal: Biosensors & Bioelectronics:

[0189] a. Volume 20, Issue 8, Pages 1459-1695 (15 Feb. 2005);

[0190] b. Volume 20, Issue 6, Pages 1029-1259 (15 Dec. 2004);

[0191] c. Volume 20, Issue 5, Pages 917-1028 (15 Nov. 2004);

[0192] d. Volume 20, Issue 1, Pages 1-142 (30 Jul. 2004); and

[0193] e. Volume 20, Issue 12, Pages 2387-2593 (15 Jun. 2005); and

[0194] (iv) Journal: Sensors & actuators B (chemical). Volume:

[0195] a. Volume 103, Issues 1-2, Pages 1-473 (29 Sep. 2004);

[0196] b. Volume 102, Issue 1, Pages 1-177 (September 2004); and

[0197] c. Volume 106, Issue 1, Pages 1-488 (29 Apr. 2005).

[0198] Tissue Characterization using chemical sensors: Chemical sensors detect the presence of various types of chemical compounds and states. For example, ions, such as, but not limited to, Na, K; dissolved gases, such as, but not limited to, Oxygen, carbon di-oxide; and Ph of solution.

[0199] Some of these sensors are further discussed in:

[0200] (i) Sensors: A comprehensive survey. Volume 2: Chemical and biochemical sensors, Part I. Ed. W. Gopel, J. Hesse, & J. N. Zenel (VCH, 1991);

[0201] (ii) Sensors: A comprehensive survey. Volume 3: Chemical and biochemical sensors, Part II. Ed. W. Gopel, J. Hesse, & J. N. Zenel (VCH, 1992); and

[0202] (iii) Journal: Sensors & actuators B (chemical). Volume:

[0203] a. Volume 103, Issues 1-2, Pages 1-473 (29 Sep. 2004);

[0204] b. Volume 102, Issue 1, Pages 1-177 (September 2004);

[0205] c. Volume 106, Issue 1, Pages 1-488 (29 Apr. 2005); and

[0206] d. Volume 108, Issues 1-2, Pages 1-1000 (22 Jul. 2005).

[0207] Tissue Characterization using Mechanical Sensors: Mechanical sensors measure a physical property of the tissue in contact with the sensor. One example of a mechanical sensor uses, tactile sensing that measures the pressure sensed on the sensor surface. An optical tactile sensor having a transparent elastic tactile portion has been taught in U.S.

Pat. No. 6,909,084 to Tachi and Kajimoto, whose disclosure is incorporated herein by reference, provides an optical tactile sensor with a tactile section and imaging means, the tactile section comprising a transparent elastic body and a plurality of groups of markers provided inside the elastic body, each marker group made up of a number of colored markers, with markers making up different marker groups having different colors for each group, and behavior of the colored markers when an object touches the elastic body being photographed by the imaging means. Preferably the marker groups have mutually different spatial arrangements.

[0208] Furthermore, mechanical sensors are discussed in: Sensors: A comprehensive survey. Volume 7: Mechanical sensors. Ed. W. Gopel, J. Hesse, & J. N. Zenel (VCH, 1994).

[0209] It will be appreciated that the method, in accordance with the present invention may adapted for human tissue and for animal tissue.

[0210] It will be appreciated that the method, in accordance with the present invention may performed during a surgical operation, wherein the external surface of the tissue is an incision surface.

[0211] Alternatively, the external surface of the tissue is skin.

[0212] Alternatively, the external surface of the tissue is lining of a lumen.

[0213] It is expected that during the life of this patent many relevant broad-band sensors, for tissue characterization will be developed and the scope of the term broad-band sensor, for tissue characterization is intended to include all such new technologies a priori.

[0214] As used herein the term "about" and "substantially" refer to $\pm 20\%$.

[0215] It is appreciated that certain features of the invention, which are, for clarity, described in the context of separate embodiments, may also be provided in combination in a single embodiment. Conversely, various features of the invention, which are, for brevity, described in the context of a single embodiment, may also be provided separately or in any suitable subcombination.

[0216] Although the invention has been described in conjunction with specific embodiments thereof, it is evident that many alternatives, modifications and variations will be apparent to those skilled in the art. Accordingly, it is intended to embrace all such alternatives, modifications and variations that fall within the spirit and broad scope of the appended claims.

[0217] All publications, patents and patent applications mentioned in this specification are herein incorporated in their entirety by reference into the specification, to the same extent as if each individual publication, patent or patent application was specifically and individually indicated to be incorporated herein by reference. In addition, any citation or identification of any reference in this application shall not be construed as an admission that such reference is available as prior art to the present invention.

What is claimed is:

1. A device for tissue characterization, comprising:
 - a structure;
 - a first mechanism, associated with said structure, configured for exerting a first force on a tissue, for fixing the tissue to said structure, so as to substantially immobilize the tissue; and
 - a second mechanism, associated with said structure, configured for pressing a sensor against an external surface of the immobilized tissue, thereby exerting a second force on the immobilized tissue,
 wherein at least a component of said first force is in opposition to at least a component of said second force, forcing the immobilized tissue against said sensor, and forcing said sensor against the immobilized tissue, bringing about an effective contact between said sensor and the immobilized tissue.
2. The device of claim 1, wherein said effective contact is a contact level of 95%
3. The device of claim 1, wherein said effective contact is a contact level of 99%
4. The device of claim 1, wherein said effective contact is a contact level of 99.8%
5. The device of claim 1, wherein said sensor is a sensor of a wavelength λ , and an average distance t_1 , between external-most surfaces of the tissue and said sensor is such that $t_1 < \lambda/3$.
6. The device of claim 1, wherein said sensor is a sensor of a wavelength λ , and an average distance t_1 , between external-most surfaces of the tissue and said sensor is such that $t_1 < \lambda/10$.
7. The device of claim 1, wherein said sensor is a sensor of a wavelength λ , and an average distance t_1 , between external-most surfaces of the tissue and said sensor is such that $t_1 < \lambda/100$.
8. The device of claim 1, wherein an average distance t_1 , between external-most surfaces of the tissue and said sensor, is less than 500 Angstroms.
9. The device of claim 1, wherein an average distance t_1 , between external-most surfaces of the tissue and said sensor, is less than 50 Angstroms.
10. The device of claim 1, wherein an average distance t_1 , between external-most surfaces of the tissue and said sensor, is less than 5 Angstroms.
11. The device of claim 1, wherein said first mechanism is a suction source, for fixing and substantially immobilizing the tissue, by suction.
12. The device of claim 1, wherein said first mechanism is a gripping device, for gripping the tissue.
13. The device of claim 1, wherein said second mechanism is a piston, configured for sliding proximally and distally, and containing said sensor at a proximal end thereof.
14. The device of claim 13, wherein said piston is further configured for vibrating laterally, as it slides proximally, to provide a gliding-sweeping motion against the tissue.
15. The device of claim 13, wherein said piston is configured to slide proximally a predetermined distance.
16. The device of claim 13, wherein said piston is configured to slide proximally until a predetermined force is reached.

17. The device of claim 13, and further including a spring, for regulating said second force.

18. The device of claim 1, wherein said sensor is selected from the group consisting of an optical sensor, an MRI sensor, an RF sensor, a MW sensor, an X-ray sensor, an ultrasound sensor, a temperature sensor, an infrared thermography sensor, a biosensor, a chemical sensor, and a mechanical sensor.

19. A system for tissue characterization, comprising:

a device for tissue characterization, which comprises:

a structure;

a first mechanism, associated with said structure, configured for exerting a first force on a tissue, for fixing the tissue to said structure, so as to substantially immobilize the tissue; and

a second mechanism, associated with said structure, configured for pressing a sensor against an external surface of the immobilized tissue, thereby exerting a second force on the immobilized tissue,

wherein at least a component of said first force is in opposition to at least a component of said second force, forcing the immobilized tissue against said sensor, and forcing said sensor against the immobilized tissue, thus bringing about an effective contact between said sensor and the immobilized tissue; and

a signal analyzer, in signal communication with said sensor.

20. The system of claim 19, and further including a signal generator.

21. The system of claim 19, and further including a computer, in communication with said signal analyzer.

22. A method for tissue characterization, comprising:

providing a device for tissue characterization, which comprises:

a structure;

a first mechanism, associated with said structure, configured for exerting a first force on a tissue, for fixing the tissue to said structure, so as to substantially immobilize the tissue; and

a second mechanism, associated with said structure, configured for pressing a sensor against an external surface of the immobilized tissue, thereby exerting a second force on the immobilized tissue,

wherein at least a component of said first force is in opposition to at least a component of said second force, forcing the immobilized tissue against said sensor, and forcing said sensor against the immobilized tissue, thus bringing about an effective contact between said sensor and the immobilized tissue;

fixing the tissue to said structure, thus substantially immobilizing the tissue; and

pressing said sensor against the external surface of the immobilized tissue, thereby exerting said second force on the immobilized tissue, wherein at least said component of said first force is in opposition to at least said component of said second force, forcing the immobilized tissue against said sensor, and forcing said sensor

against the immobilized tissue, thus bringing about said effective contact between said sensor and the immobilized tissue.

23. A method of tissue characterization, comprising:

exerting a first force on a tissue, for fixing the tissue to a structure, so as to substantially immobilize the tissue; and

pressing a sensor against an external surface of the immobilized tissue, thereby exerting a second force on

the immobilized tissue, wherein at least a component of said first force is in opposition to at least a component of said second force, forcing the immobilized tissue against said sensor, and forcing said sensor against the immobilized tissue, thus bringing about an effective contact between said sensor and the immobilized tissue.

* * * * *

专利名称(译)	用于形成有效的传感器与组织接触的装置		
公开(公告)号	US20070032739A1	公开(公告)日	2007-02-08
申请号	US11/196732	申请日	2005-08-04
[标]申请(专利权)人(译)	沙丘医疗设备有限公司		
申请(专利权)人(译)	DUNE医疗器械有限公司.		
当前申请(专利权)人(译)	DUNE医疗器械有限公司.		
[标]发明人	HASHIMSHONY DAN COHEN GIL GELTNER IDDO		
发明人	HASHIMSHONY, DAN COHEN, GIL GELTNER, IDDO		
IPC分类号	A61B5/00		
CPC分类号	A61B5/6834 A61B5/4381		
其他公开文献	US8721565		
外部链接	Espacenet USPTO		

摘要(译)

提供了一种用于组织表征的装置和方法，该装置包括：结构；第一机构，与所述结构相关联，用于在组织上施加第一力，用于将组织固定到所述结构上，从而基本上固定组织；第二机构，与所述结构相关联，被配置为将传感器压靠在固定组织的外表面上，从而在固定组织上施加第二力，其中所述第一力的至少一部分与至少一个相反。所述第二力的分量，迫使固定的组织抵靠所述传感器，并迫使所述传感器抵靠固定的组织，从而在所述传感器和固定的组织之间产生有效的接触。

