



US 20060253107A1

(19) **United States**

(12) **Patent Application Publication**  
**Hashimshony et al.**

(10) **Pub. No.: US 2006/0253107 A1**

(43) **Pub. Date: Nov. 9, 2006**

(54) **CLEAN MARGIN ASSESSMENT TOOL**

(52) **U.S. Cl. .... 606/1; 606/41; 600/439; 600/587**

(75) Inventors: **Dan Hashimshony**, Givat Ada (IL); **Gil Cohen**, Jerusalem (IL); **Iddo Geltner**, Herzlia (IL)

(57) **ABSTRACT**

Correspondence Address:  
**Martin Moynihan**  
**PRSTL, Inc**  
**P O box 16446**  
**Arlington, VA 22215 (US)**

An integrated tool is provided, having a tissue-type sensor, for determining the tissue type at a near zone volume of a tissue surface, and a distance-measuring sensor, for determining the distance to an interface with another tissue type, for (i) confirming an existence of a clean margin of healthy tissue around a malignant tumor, which is being removed, and (ii) determining the depth of the clean margin. The integrated tool may further include a position tracking device and an incision instrument. The soft tissue may be held within a fixed frame, while the tumor is being removed. Additionally a method for malignant tumor removal is provided, comprising, fixing the soft tissue within a frame, performing imaging with the hand-held, integrated tool, from a plurality of locations and orientations around the soft tissue, reconstructing a three-dimensional image of the soft tissue and the tumor within, defining a desired clean margin on the reconstructed image, calculating a recommended incision path, displaying the recommended path on the reconstructed image, and cutting the tissue while determining its type, at the near zone volume of the incision surface. The method may further include continuously imaging with the cutting, continuously correcting the reconstructed image and the recommended incision path, and continuously determining the tissue type, at the near zone volume of the incision surface.

(73) Assignee: **DUNE MEDICAL DEVICES LTD.**, CAESARIA (IL)

(21) Appl. No.: **10/558,831**

(22) PCT Filed: **Mar. 23, 2005**

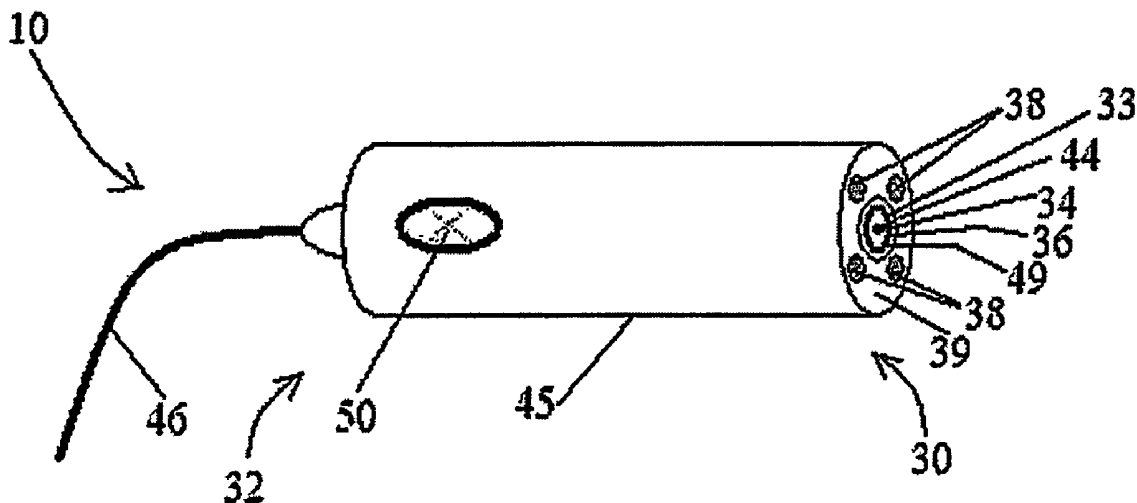
(86) PCT No.: **PCT/IL05/00330**

**Related U.S. Application Data**

(60) Provisional application No. 60/555,901, filed on Mar. 23, 2004.

**Publication Classification**

(51) **Int. Cl.**  
*A61B 17/00* (2006.01)  
*A61B 18/18* (2006.01)  
*A61B 8/00* (2006.01)  
*A61B 5/103* (2006.01)  
*A61B 5/117* (2006.01)



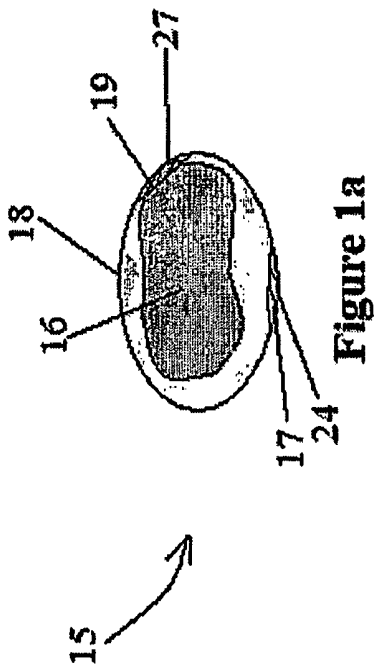


Figure 1a

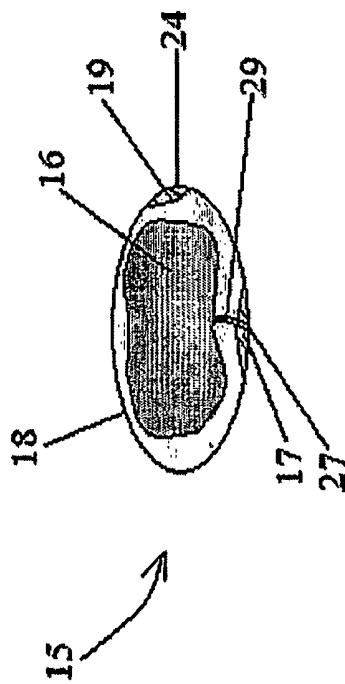


Figure 1b

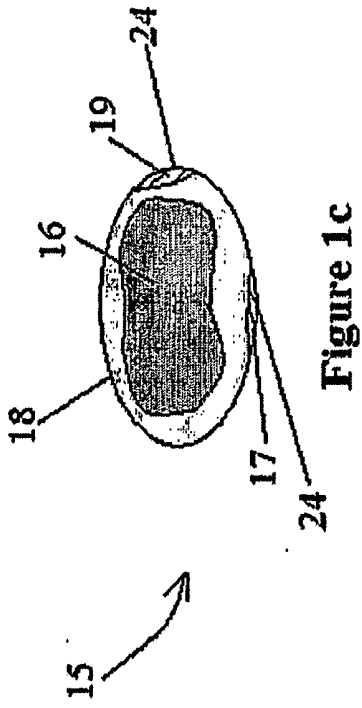


Figure 1c

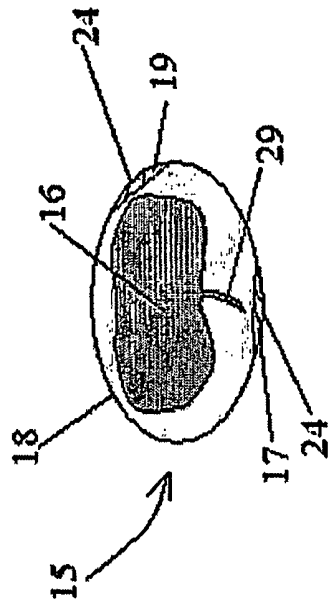


Figure 1d

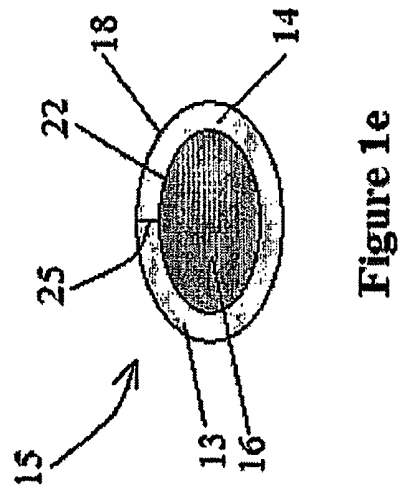


Figure 1e

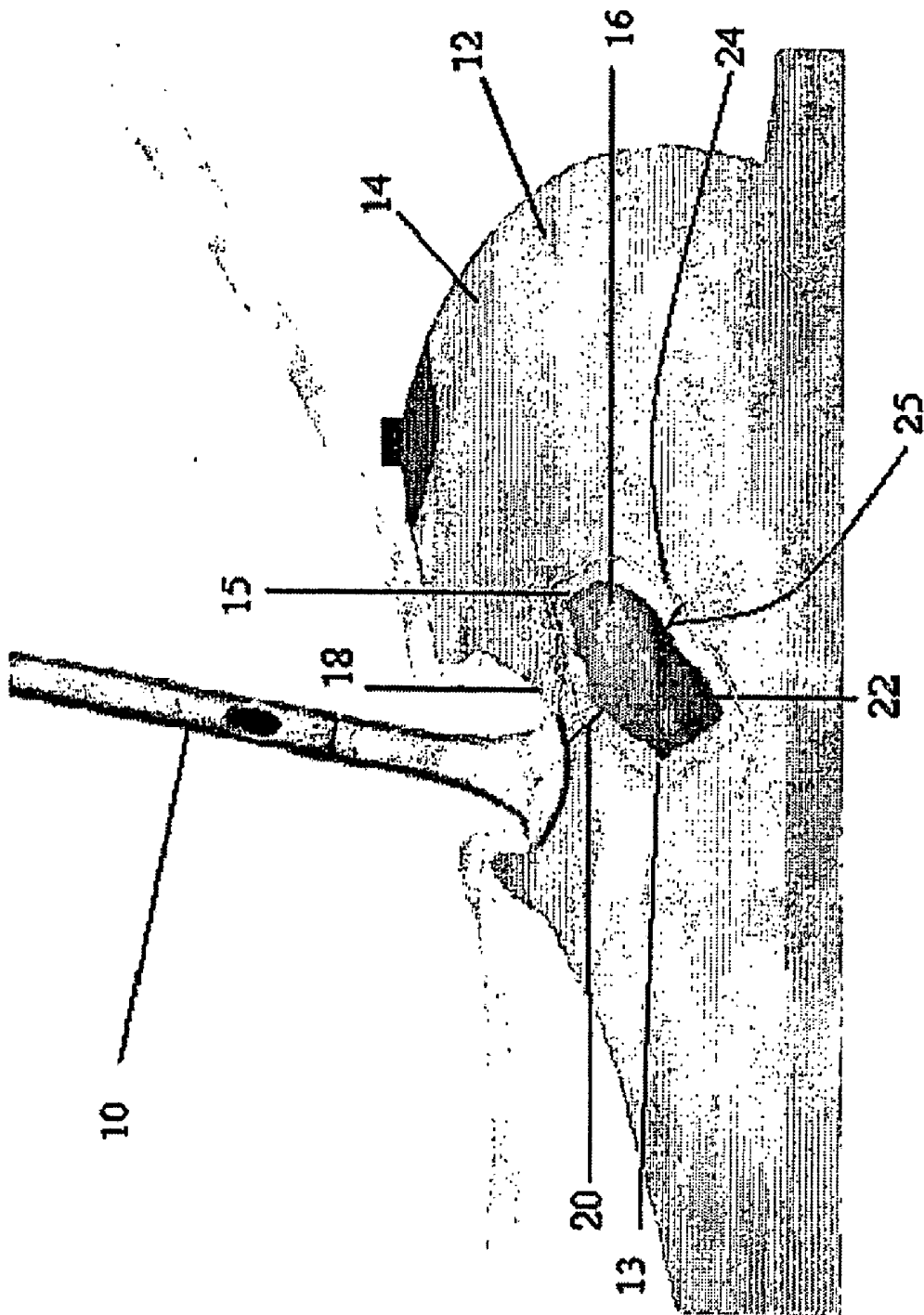


Figure 1f

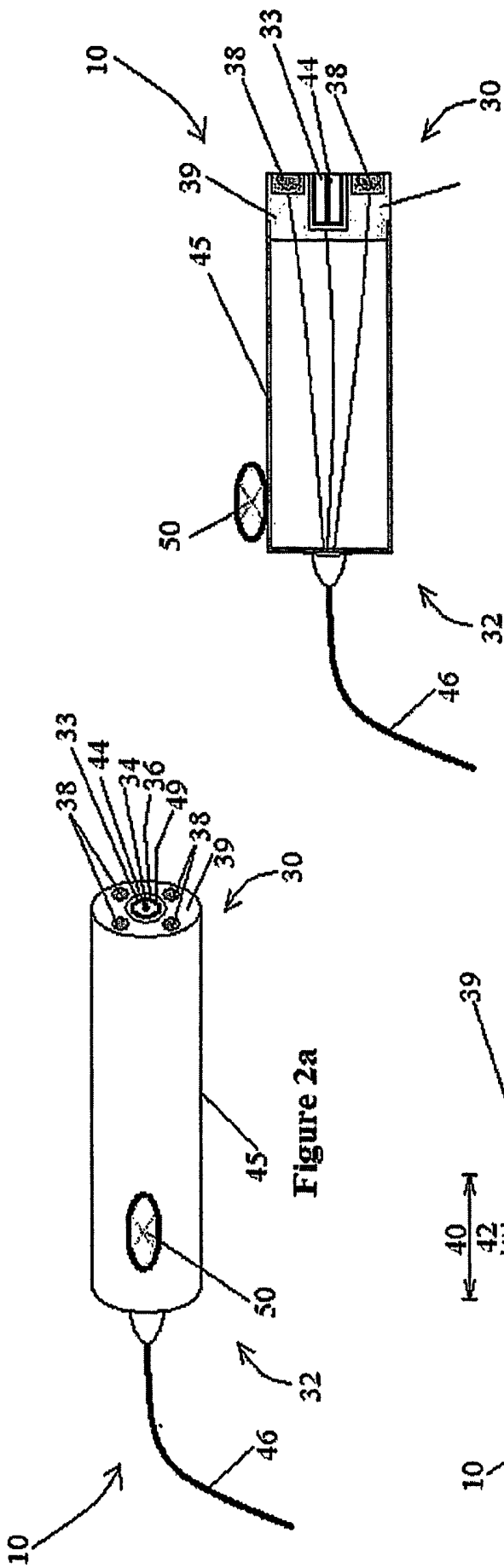


Figure 2a

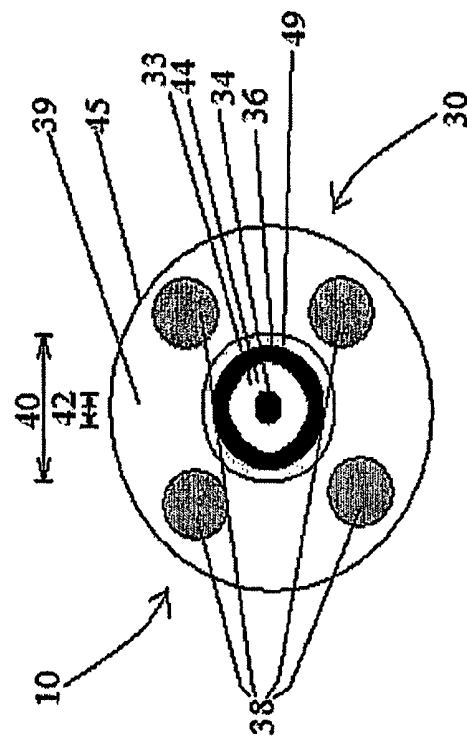
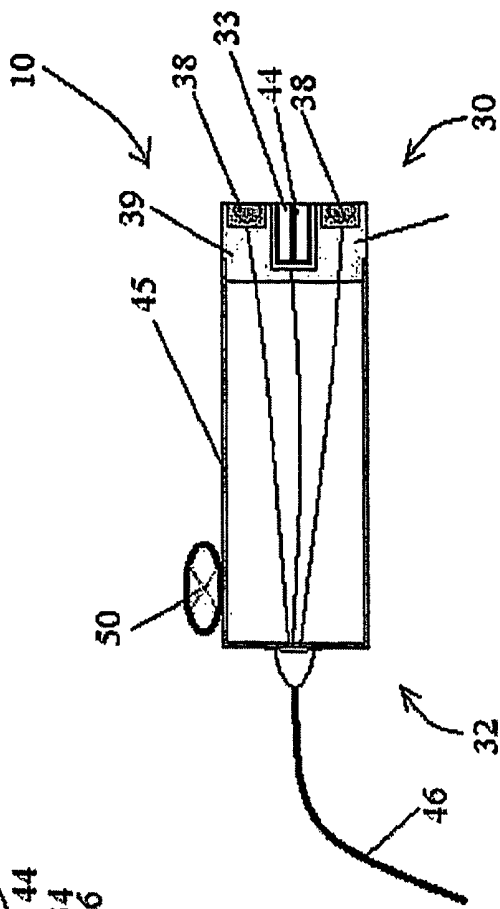


Figure 2b

Figure 2c



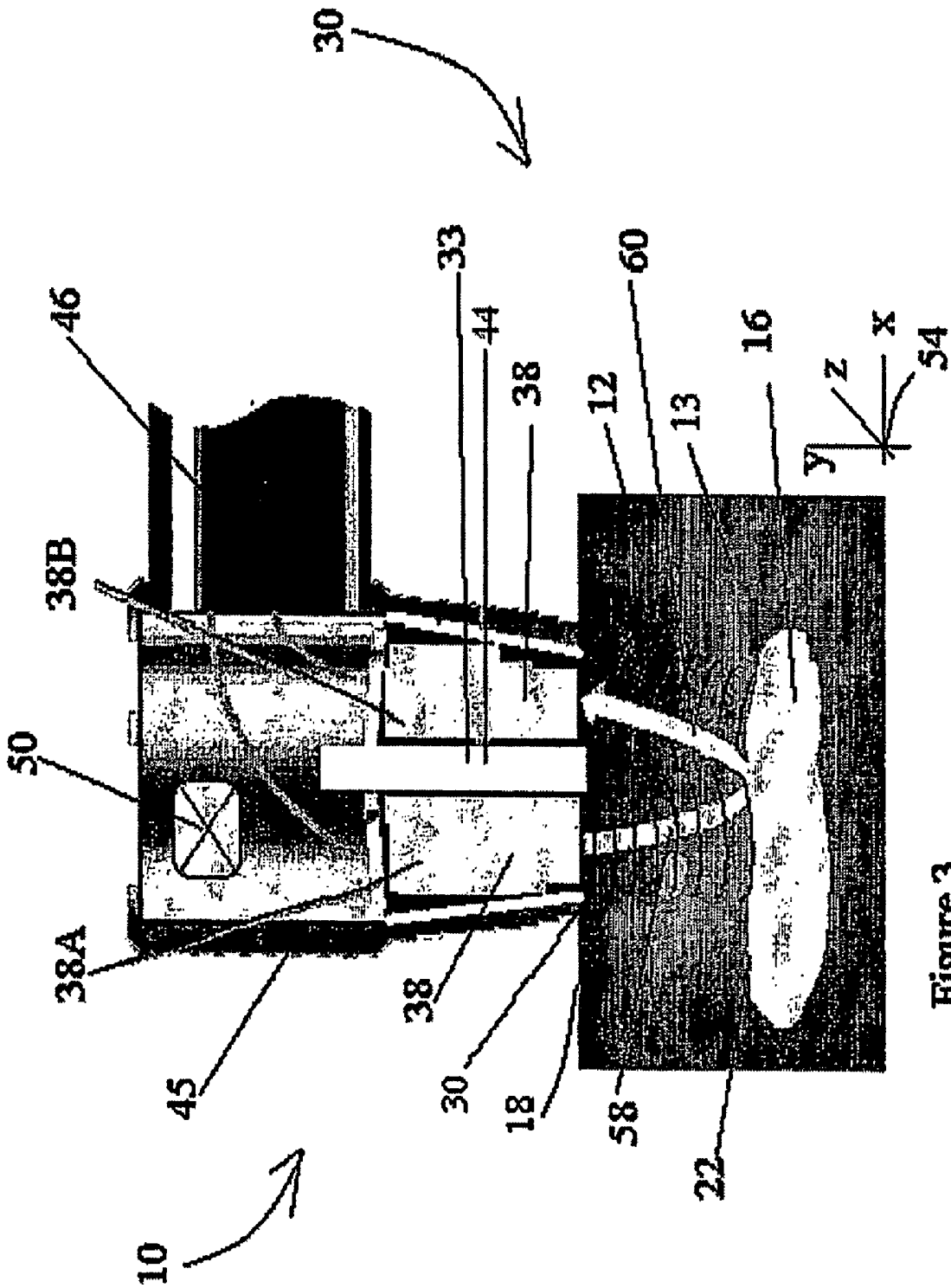


Figure 3

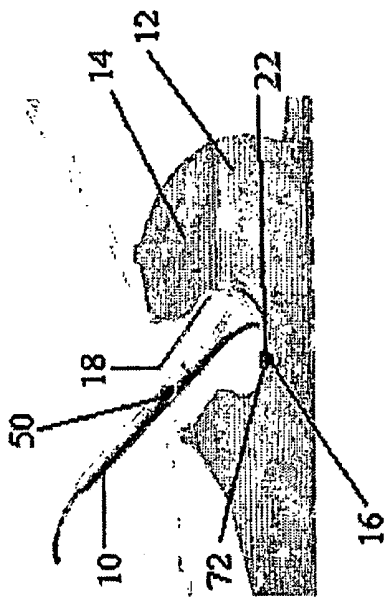


Figure 4b

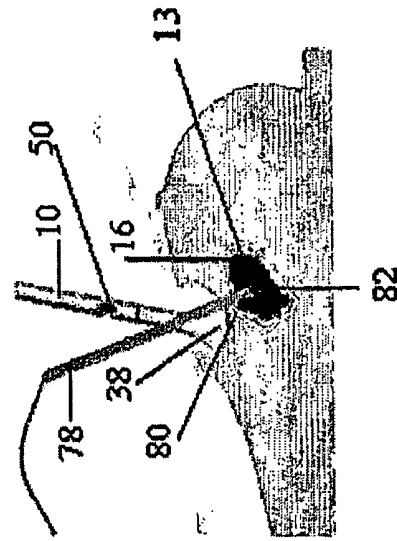


Figure 4d

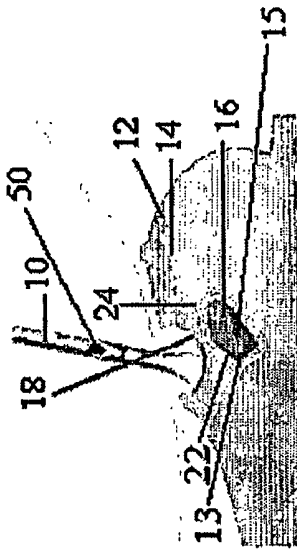


Figure 4a

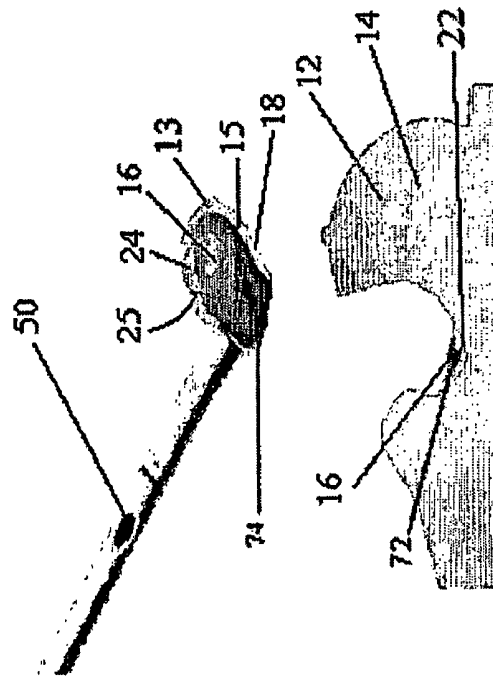


Figure 4c

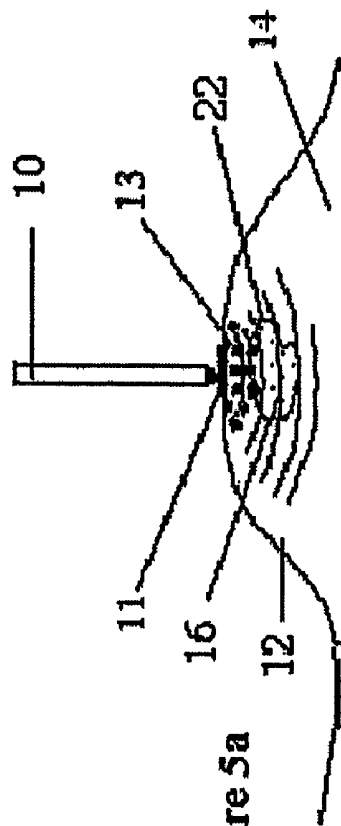


Figure 5a

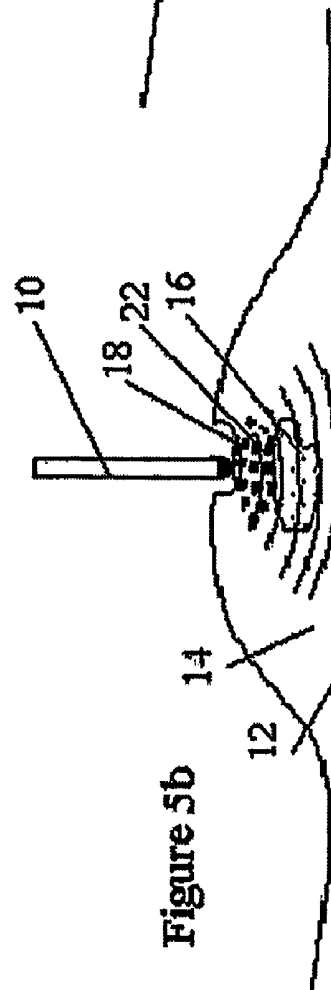


Figure 5b

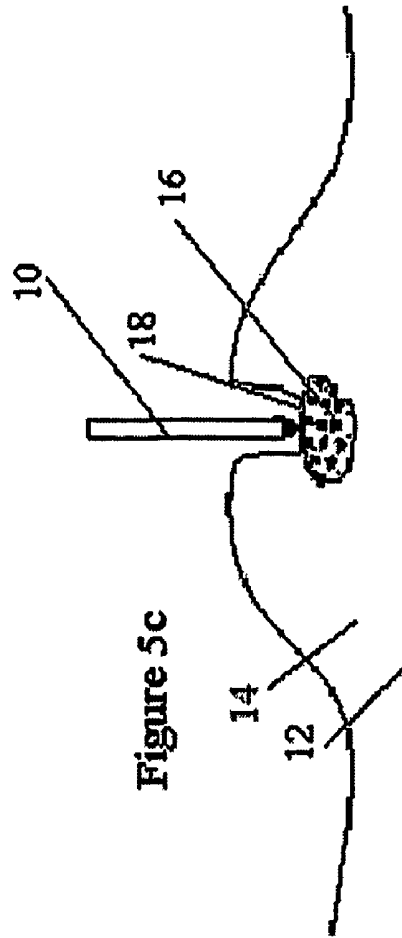


Figure 5c

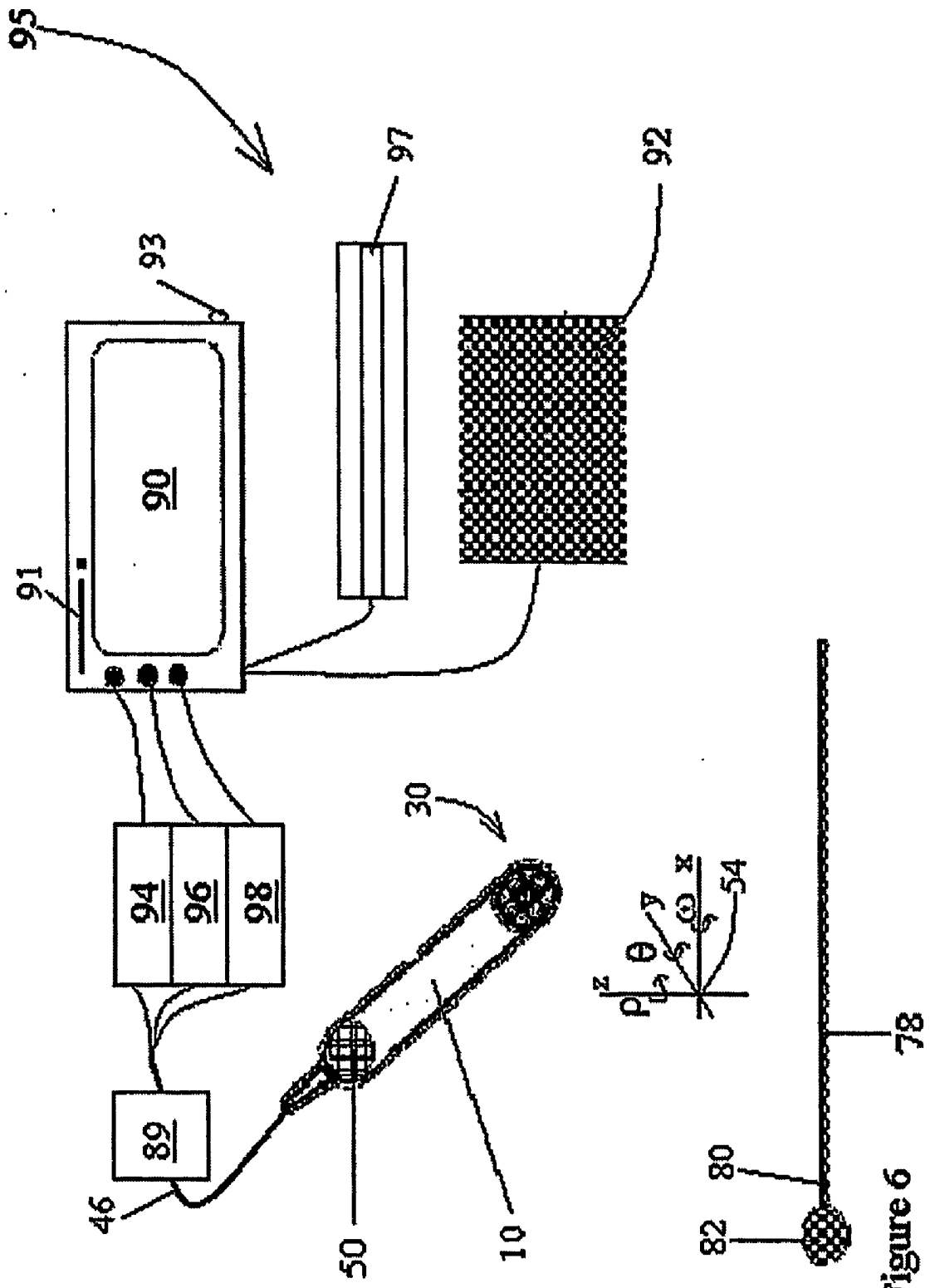


Figure 6

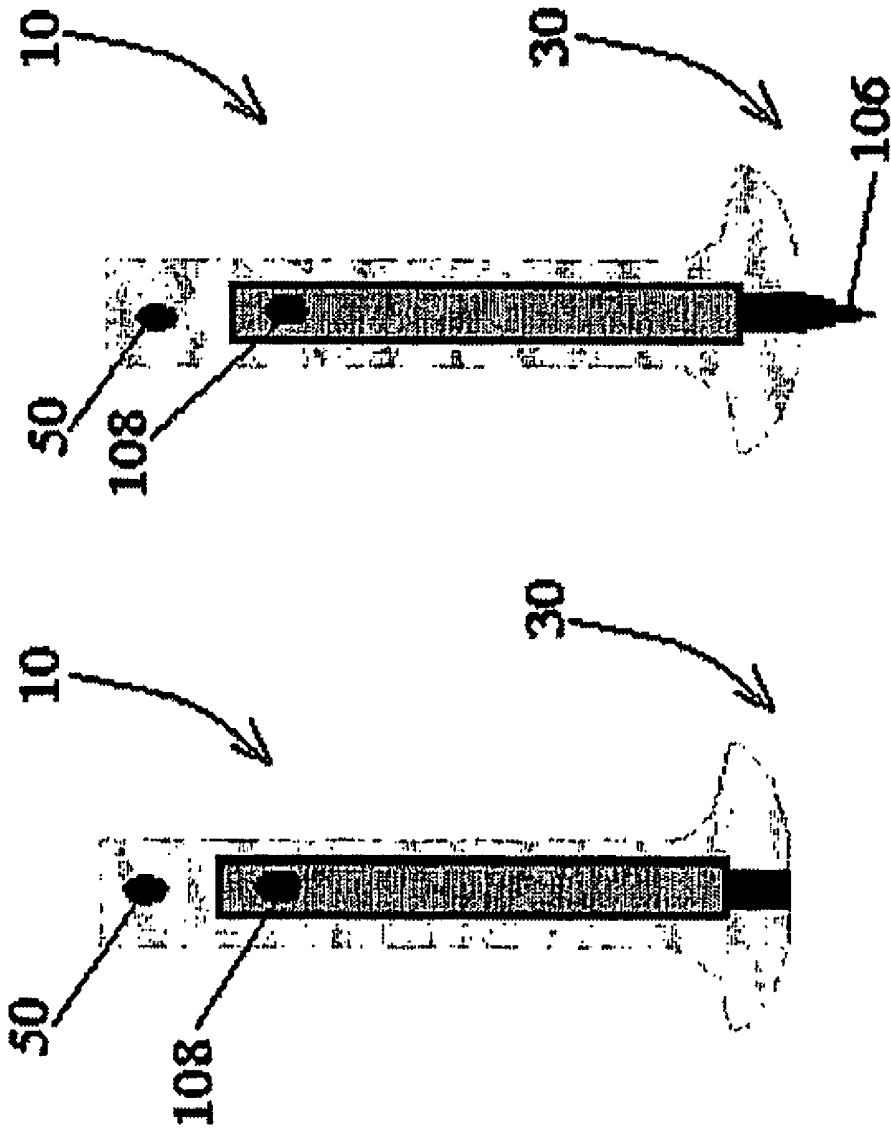


Figure 7b

Figure 7a

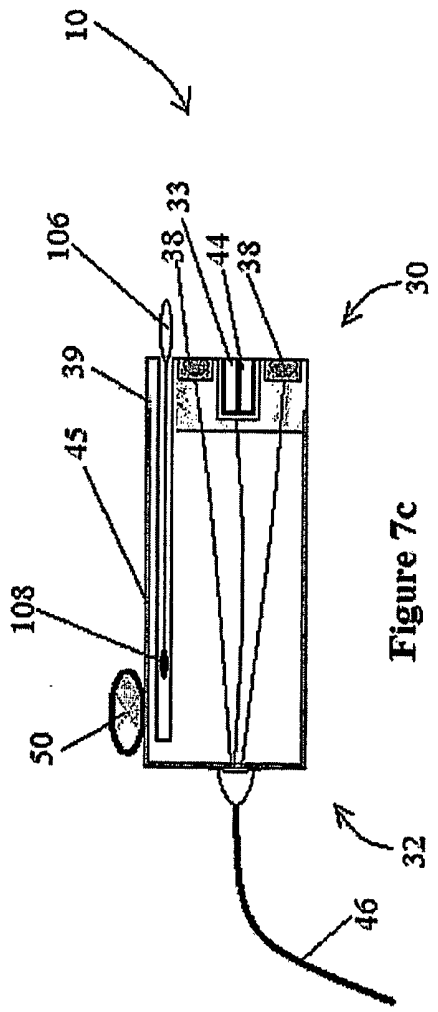


Figure 7c

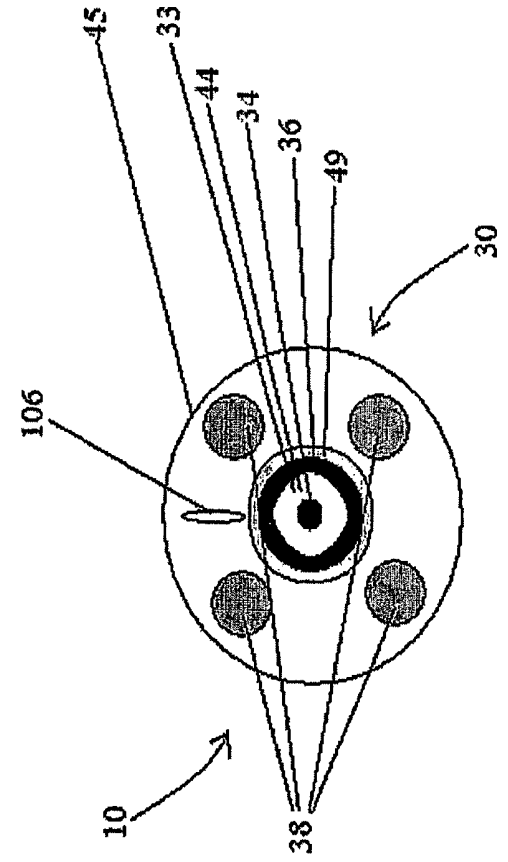


Figure 7d

Figure 8a

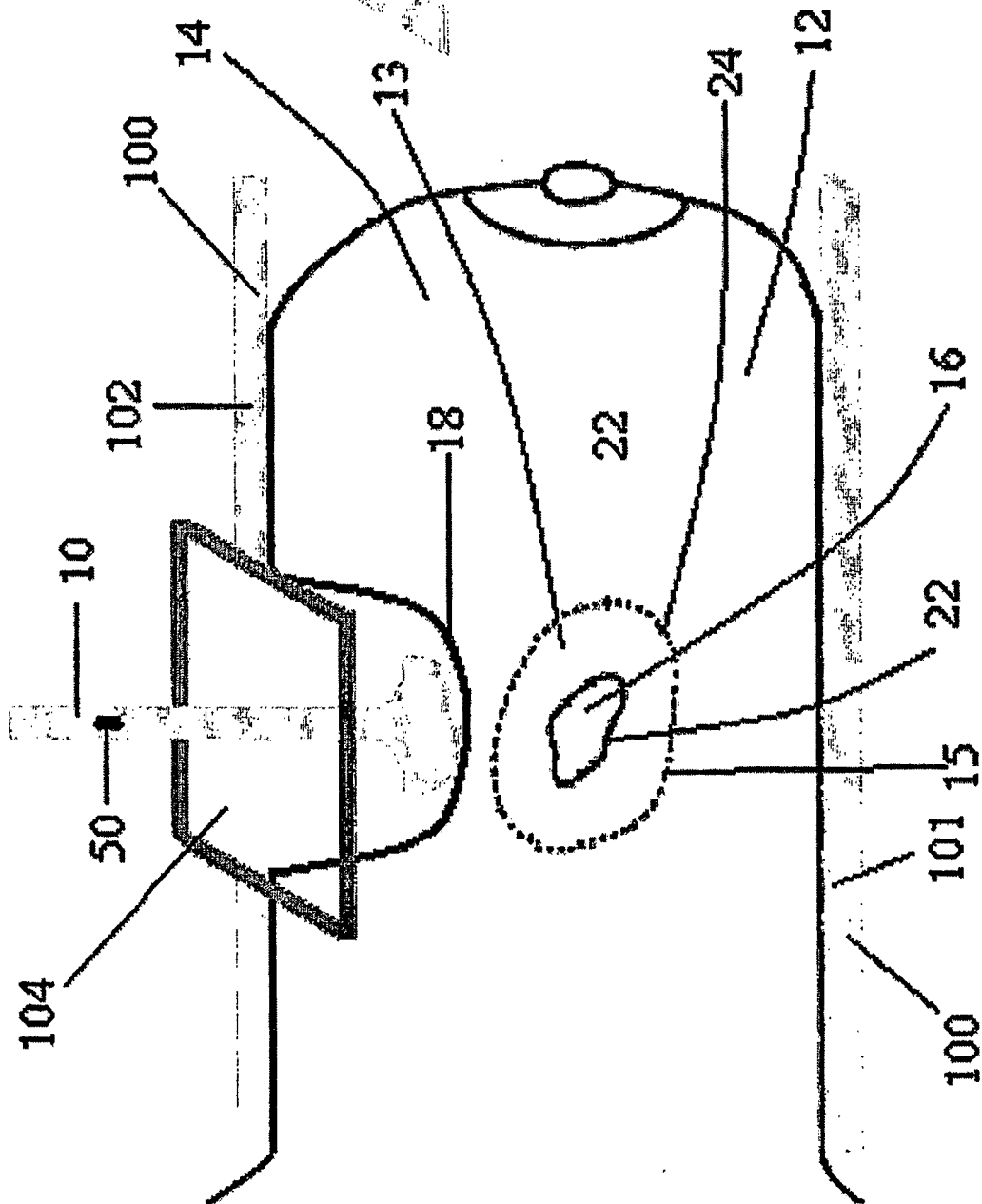
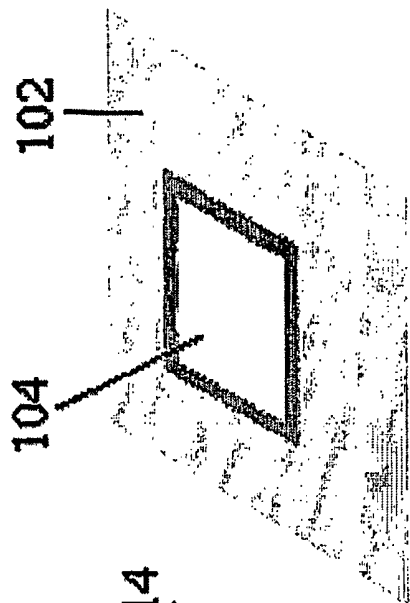


Figure 8b



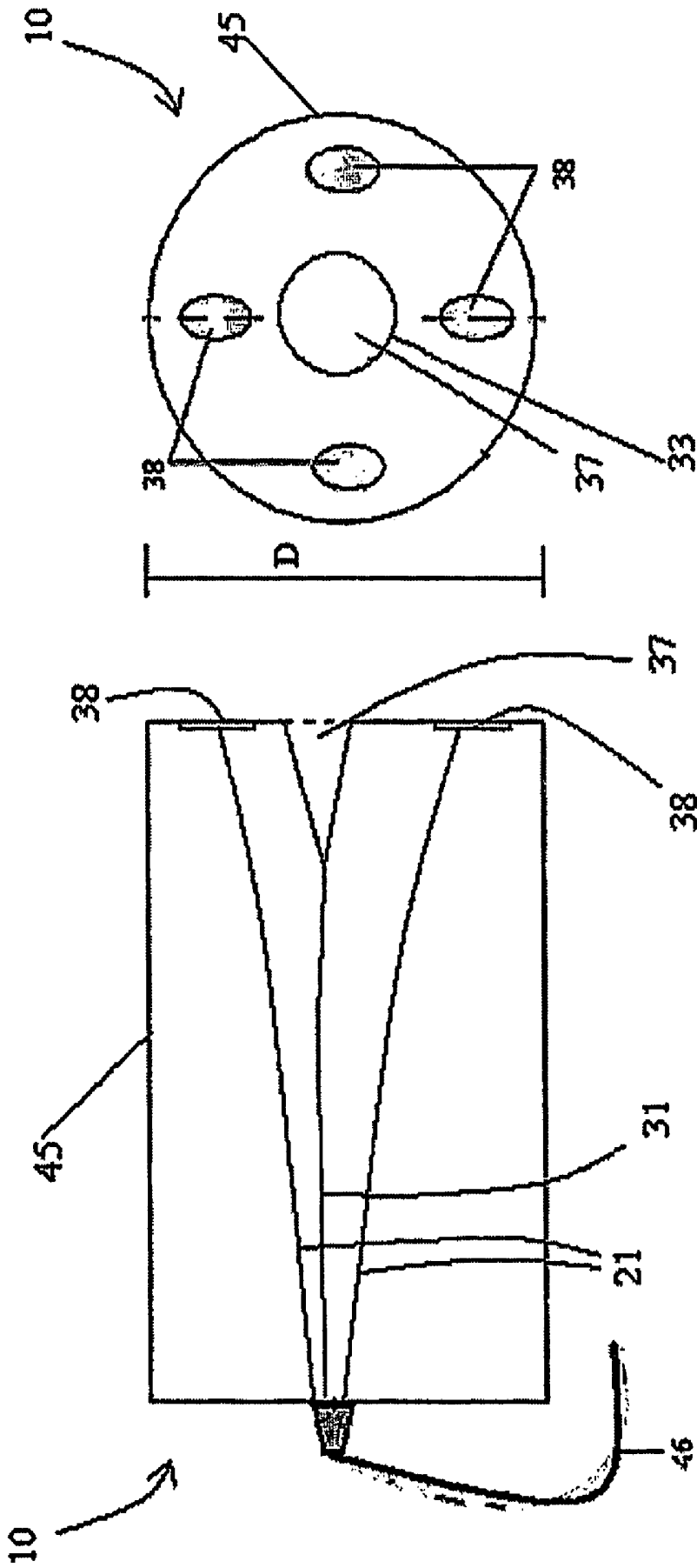


Figure 9a

Figure 9b

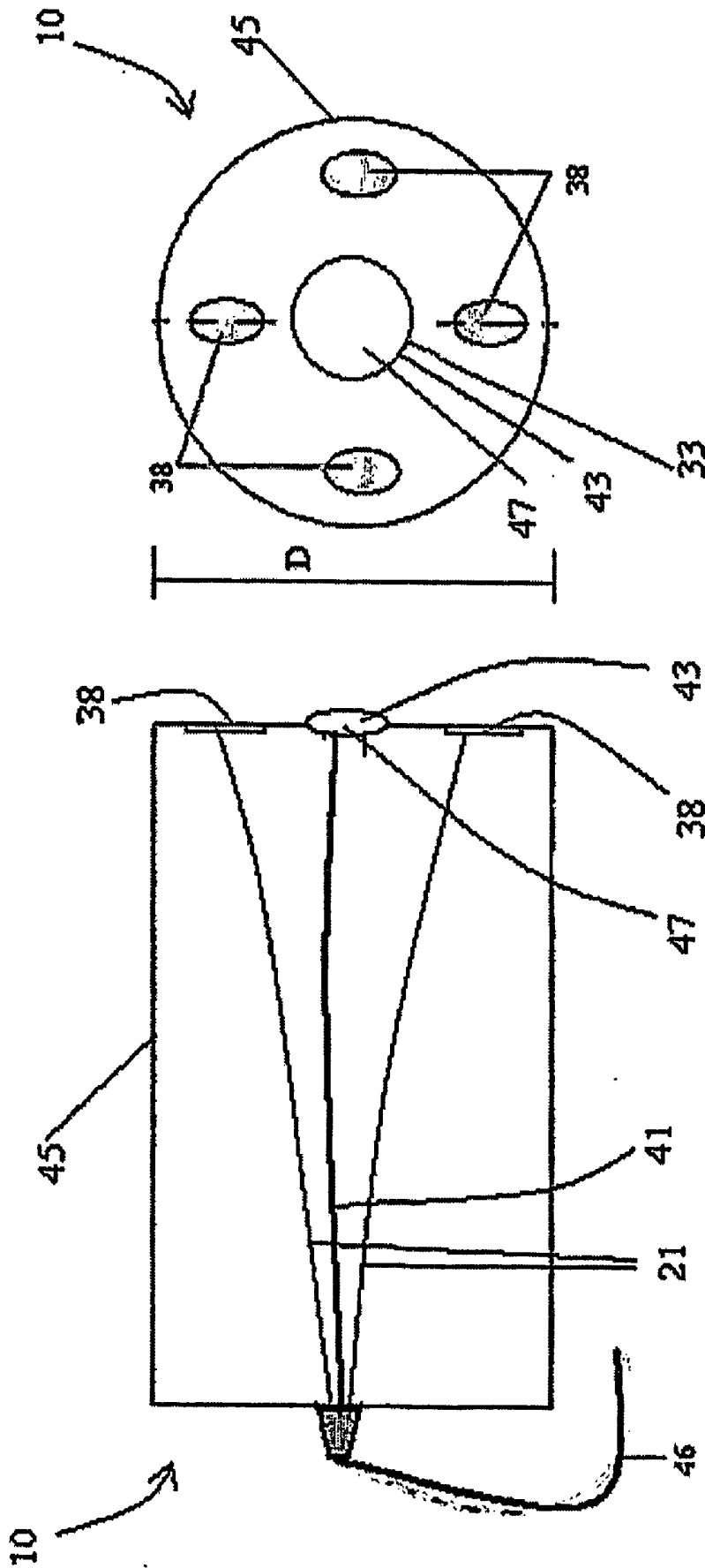


Figure 10a

Figure 10b

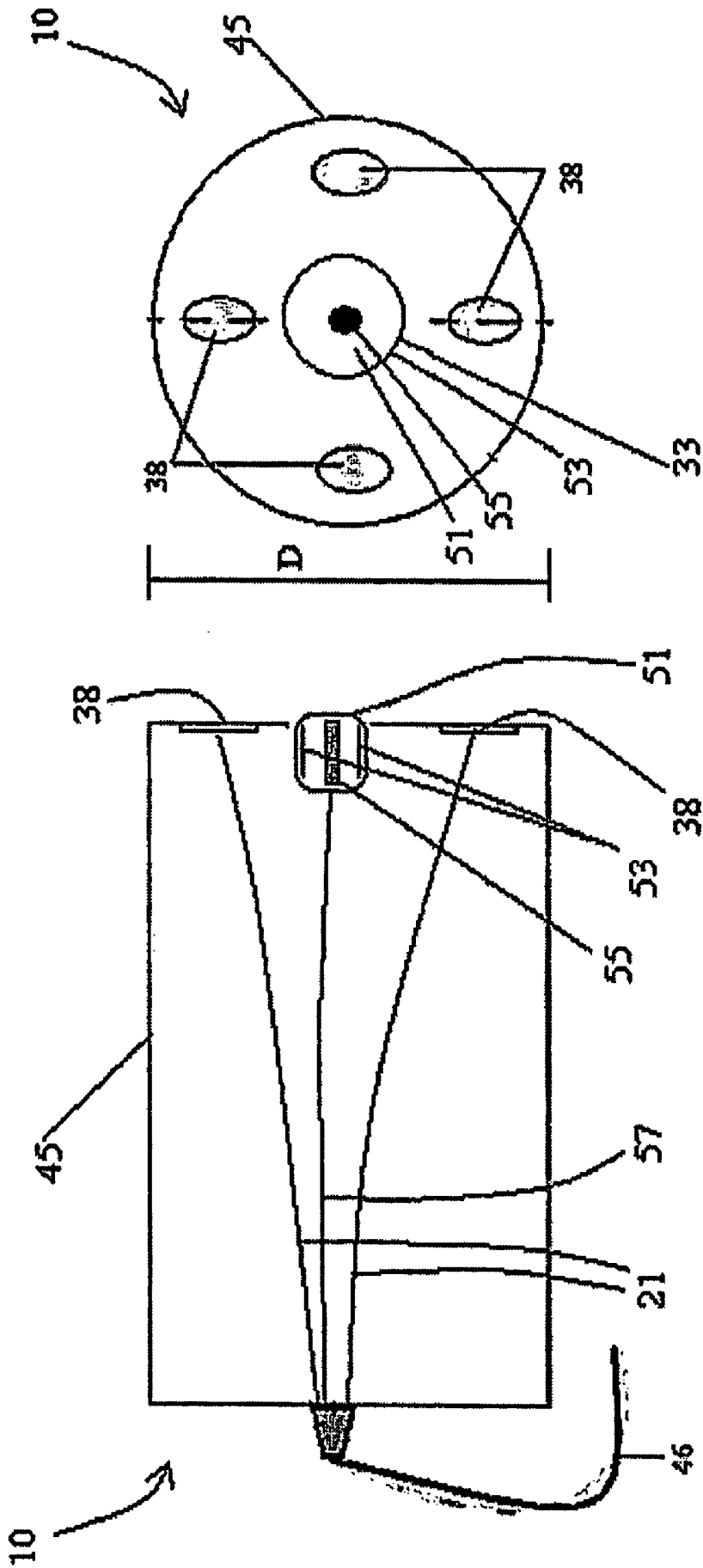


Figure 11b

Figure 11a

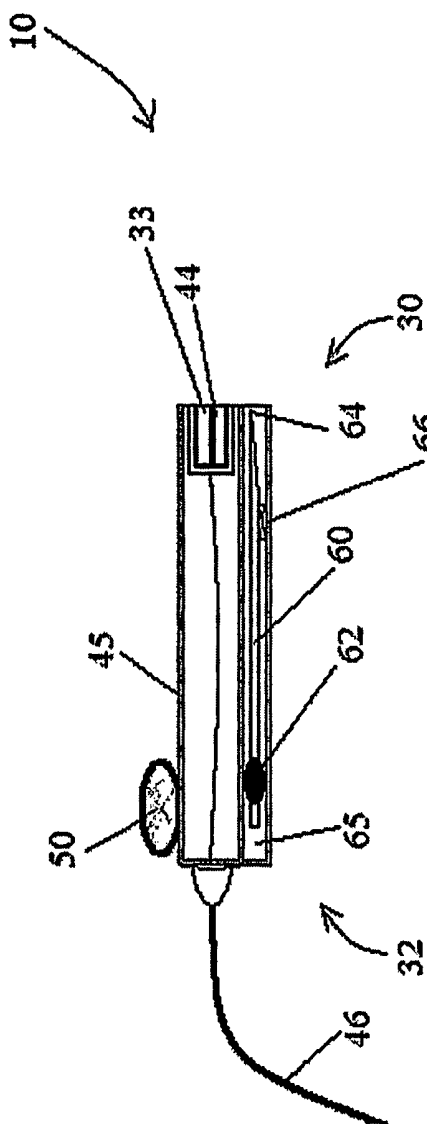


Figure 12a

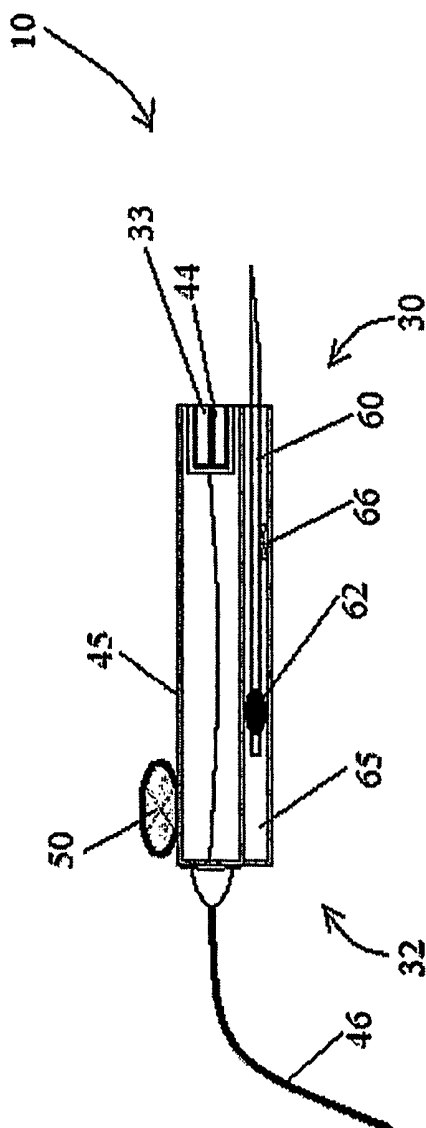


Figure 12b

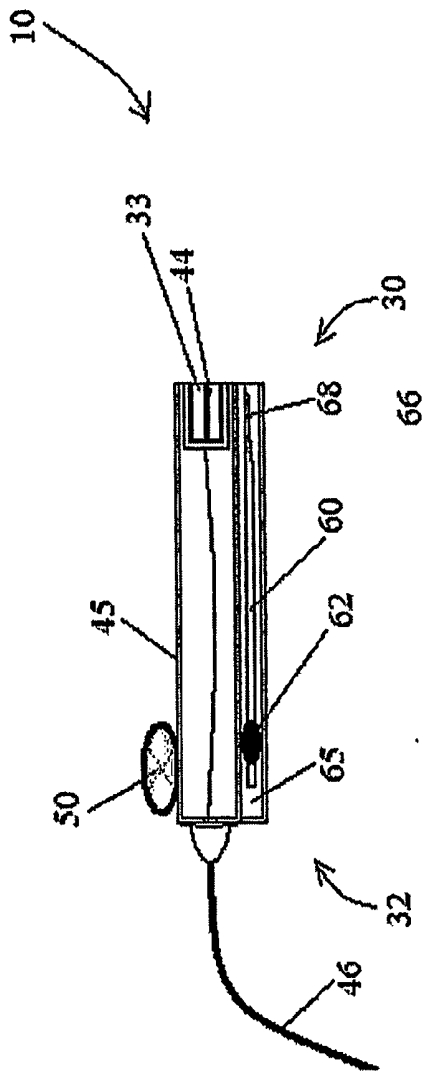


Figure 13a

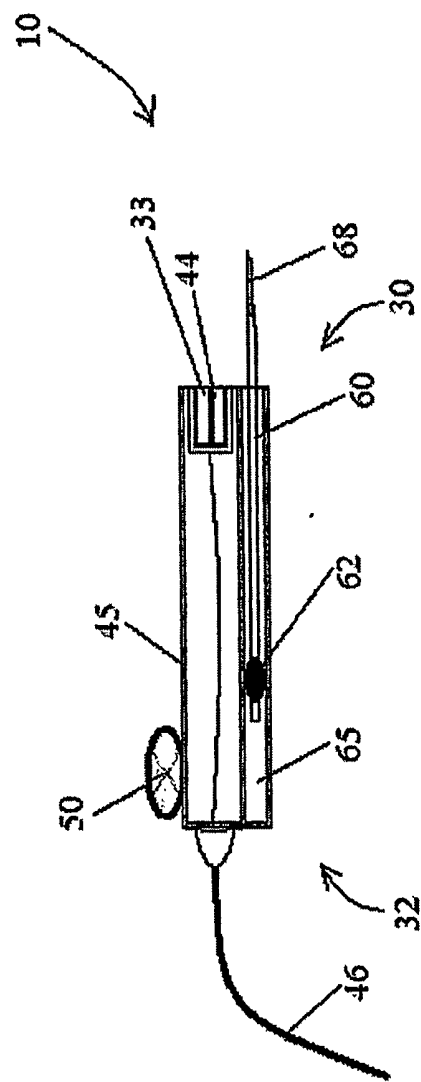
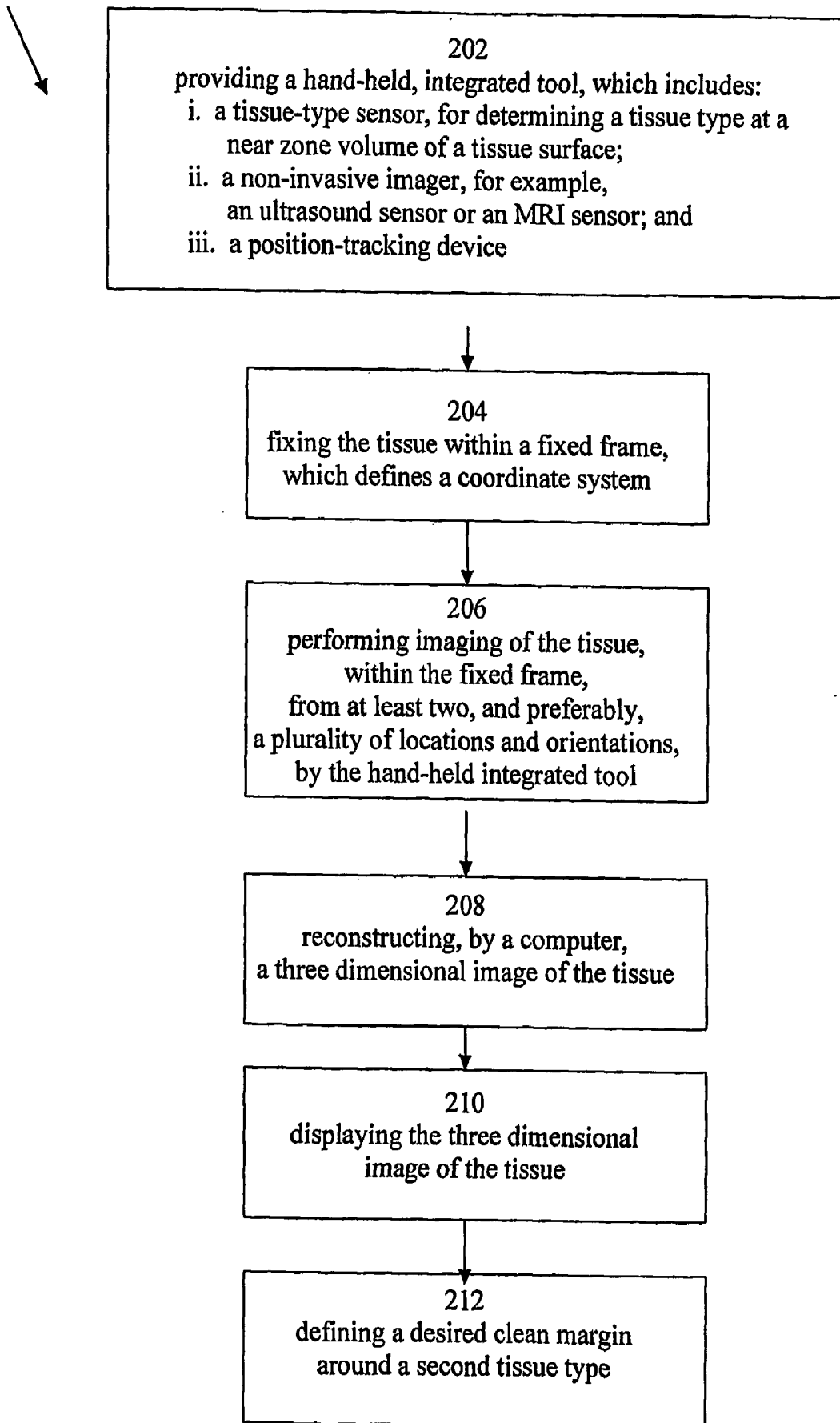


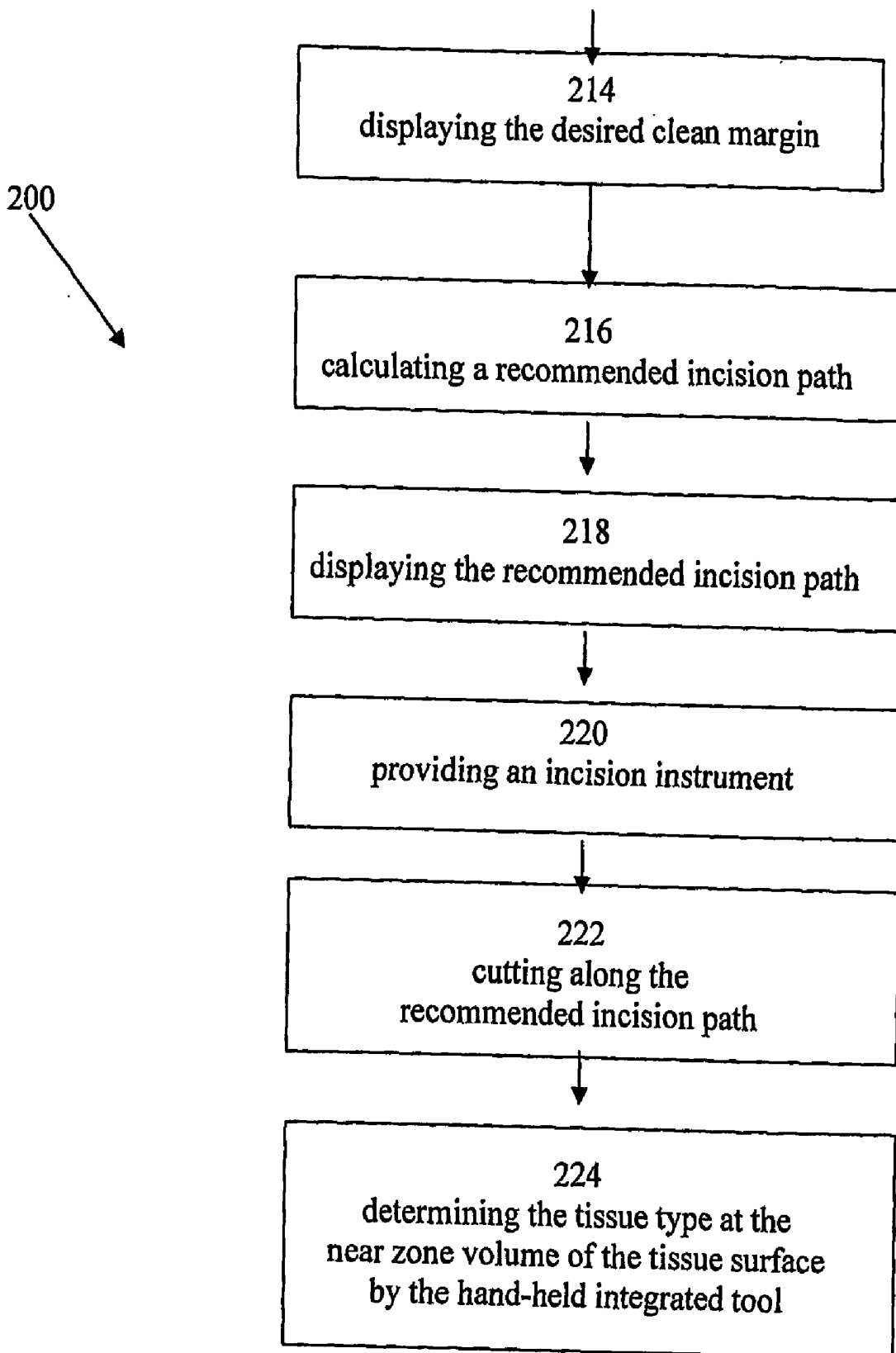
Figure 13b

**Figure 14a**

200

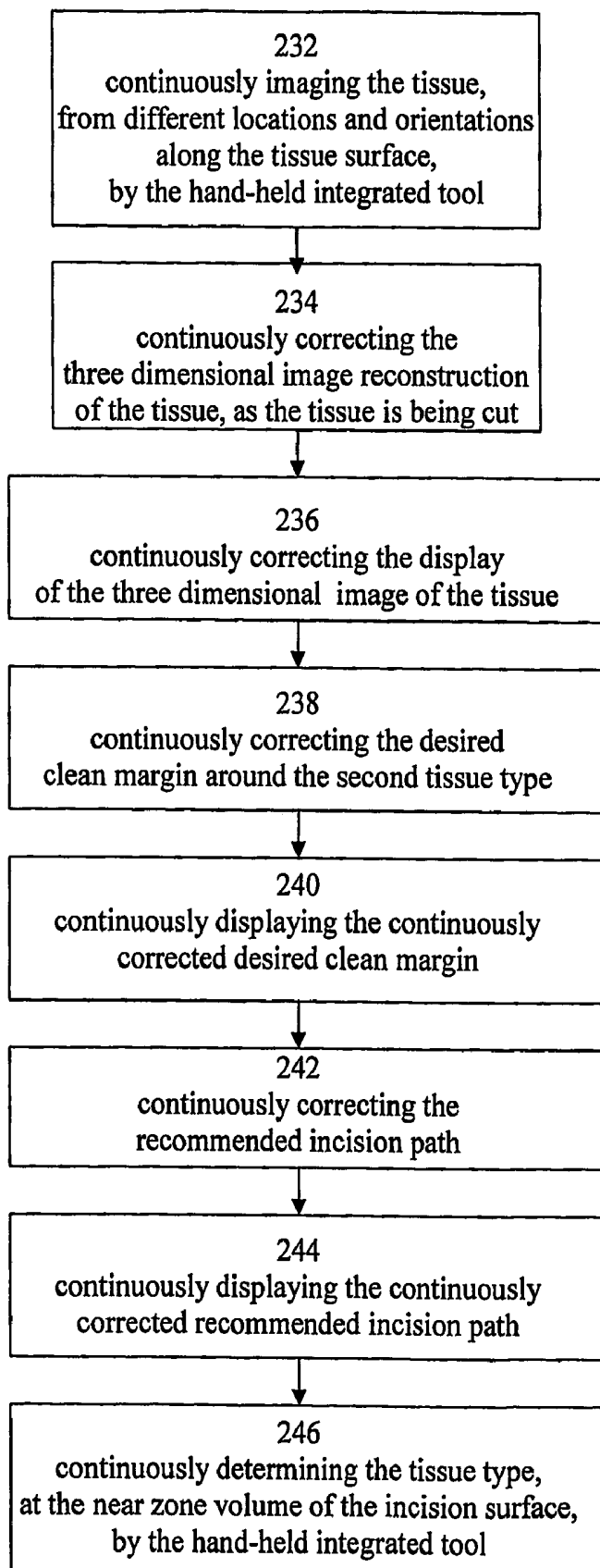


**Figure 14a**  
(continued)



**Figure 14b**

230



## CLEAN MARGIN ASSESSMENT TOOL

### FIELD AND BACKGROUND OF THE INVENTION

[0001] The present invention relates generally, to a medical tool for tissue characterization, and specifically, to an integrated tool, having a tissue-type sensor, for determining the tissue type at an incision edge, and a distance-measuring sensor, for determining the distance to an interface with another tissue type. The tool is operable for confirming an existence of a clean margin of healthy tissue around an excised tumor, and for determining the width of the margin.

[0002] When a malignant tumor is found in a breast, the patient currently has two primary treatment options, 1) mastectomy or 2) breast conserving therapy, which means, lumpectomy, followed by radiation therapy. Generally, breast conserving therapy is indicated for patients with Stage T1 or T2 cancers, of between less than about 0.5 and about 5 cm in greatest dimension.

[0003] To localize the tumor within the breast, a radiologist may place a guide wire under x-ray or ultrasound guidance, so that the proximal tip of the guide wire, with respect to the tissue, is in the tumor. Alternatively, an imaging modality alone, for example, mammography, CT, ultrasound, or another imaging modality may be used to locate the tumor. The patient is then transported to the operating room, where the surgeon uses the guide wire, or the image, or palpation to locate the tumor in the breast and to excise a portion of tissue including the cancerous portion and a layer of healthy tissue surrounding the cancerous portion.

[0004] The layer of healthy tissue must enclose the cancerous portion, to ensure that all the malignancy has been removed. This layer is often referred to as a "clean margin." Although generally dependent on the size and shape of the malignant tumor that is being removed, a desired depth of the clean margin may range from 1 cell layer, or about 40 microns, to 10 mm.

[0005] Typically the surgeon uses a scalpel and (or) an electrosurgical cutting device to remove a tissue portion enclosing the tumor, in one piece, and manage bleeding. The removed portion is transported to the pathologist, who samples the margins, histologically, at specific and suspicious points, for example, at one or a few representative points on each face of the portion, to assess whether the cancer has been completely removed from the body. If the pathologists deems that cancer cells are too close to the edge of the portion, i.e., if he deems the margin infected, a re-excision is recommended, and the patient must undergo a second surgical procedure to remove more of the tissue.

[0006] There are several problems with conventional breast conserving therapy.

[0007] 1. There are technical challenges associated with placement of the guide wire tip, and the radiologist may not place the guide wire properly through the lesion. It is particularly difficult to place the guide wire at the correct depth. Also, when the guide wire is placed under x-ray guidance, the breast is compressed. When the breast is decompressed for the surgical excision, the guide wire can move, resulting in inaccurate placement thereof. Finally, the guide wire placement procedure is uncomfortable to the

patient and logistically challenging; the procedure must be coordinated with the time of surgery. Often, the easiest path for the radiologist to place the guide wire is different from the best surgical approach, so the surgeon cannot follow the guide wire down to the tumor.

[0008] 2. It is difficult to estimate correctly the full extent of the disease and the exact volume of the cancerous portion of the tumor, especially with non-palpable lesions. Non-palpable lesions are similar in their properties to normal tissue, hence harder to detect by ultrasound and mammography. Thus, the guide wire may be inaccurately placed. To compensate for the imprecision in determining the extent of the disease, the surgeon must remove much more tissue than would be required if the full extent of the cancer could be imaged in real-time. This leads to a negative impact aesthetically and emotionally on the patient.

[0009] U.S. Pat. No. 6,546,787 to Schiller et al., whose disclosure is incorporated herein by reference, provides an apparatus and method for detecting a distance from a tissue edge to a malignant tissue, enclosed therein. The apparatus comprises a needle having a strain gage, mounted on one of the needles walls. Strain signals are collected as the needle is moved through the tissue. The needle is inserted at different points to allow data collection from different points within the tissue. The data is sent together with its spatial coordinates to a computerized system, which provides an image of the structure of the examined tissue.

[0010] WO Patent 9712553 to Changus et al., whose disclosures is incorporated herein by reference, provides an apparatus for marking a predetermined margin around a tumor that is contained within a healthy tissue. The apparatus includes a needle to be inserted into the patient's body towards the malignant tissue. The needle contains margin wires that are to create a cage containing the malignant tissue within it. The needle is to reach a predetermined distance of between 7 and 13 mm and preferably 10 mm from the malignant tissue before the wires are deployed to create the cage. The cage is then used to guide the surgeon performing a lumpectomy procedure, as to the portion of tissue to be excised and its location, so that the removed tissue will include the malignant tissue with a sufficient clean margin around it. The drawback of such a procedure is that it requires exact knowledge as to the location of the malignant tissue and its boundaries while creating the cage.

[0011] US Patent applications 20040168692 and 20020059938, and U.S. Pat. Nos. 6,752,154, 6,722,371, 6,564,806, 6,405,733, all to Fogarty, et al., all entitled, "Device for accurately marking tissue," and all of whose disclosures are incorporated herein by reference, describe methods and a device for fixedly yet removably marking a volume of tissue containing a suspect region for excision. Additionally they describe methods for deployment of the device and its excision along with the marked tissue volume. At least one locator element is deployed into tissue and assumes a predetermined curvilinear shape to define a tissue border containing a suspect tissue region along a path. The locator element path preferably encompasses the distal-most portion of the tissue volume, with respect to the tool, without penetrating that volume. Multiple locator elements may be deployed to further define the tissue volume along additional paths defining the tissue volume border that do not penetrate the volume. Other localization wire embodiments of the

invention are disclosed in which the tissue volume may be penetrated by a portion of the device. Polar and tangential deployment configurations as well as a locator element that may be cold-formed by a die in the distal portion of the deployment tube into a permanent accurate shape are also disclosed.

[0012] US Patent applications 20050010131 and U.S. Pat. Nos. 6,331,166 and 6,699,206, all to Burbank et al., all of whose disclosures are incorporated herein by reference, describe a method and apparatus for precisely isolating a target lesion in a tissue, so that there is a high likelihood the lesion is removed with a margin. The apparatus comprises a biopsy instrument having a distal end (with respect to operator) adapted for entry into the patient's body, a longitudinal shaft, and a cutting element disposed along the shaft. The cutting element is actuatable between a radially retracted and extended position. Advantageously, the instrument is rotatable about its axis in the radially extended position to isolate a desired tissue specimen from surrounding tissue by defining a peripheral margin about the tissue specimen. Once the tissue specimen is isolated, it may be segmented by further manipulation of the cutting element, after which the tissue segments are preferably individually removed from the patient's body through a cannula or the like. Alternatively, the specimen may be encapsulated and removed as an intact piece.

[0013] U.S. Pat. No. 6,840,948 to Albrecht et al, whose disclosure is incorporated herein by reference, discloses a device and method for removal of tissue lesions, for example, in the breast, the liver and the lungs. The device includes a probe housing having a rotatable RF loop cutter mounted at the distal end of the probe. The RF loop cutter can include at least one electrode supplied with an RF actuating signal for cutting tissue. A rotational drive and specimen containment sheath can also be included. Real-time imaging is preferably used with the RF loop probe to assist in placement of the probe, and to more accurately assess a desired excision volume.

[0014] Ultrasound or ultrasonography is a medical imaging technique, using high frequency sound waves in the range of about 1 to 20 MHz and their echoes. The sound waves travel in the body and are reflected by interfaces between different types of tissues, such as between a healthy tissue and a denser cancerous tissue, or between a soft tissue and a bone. The ultrasound probe receives the reflected sound waves and the associated instrumentation calculates the distances from the probe to the reflecting boundaries.

[0015] Ultrasound probes are formed of piezoelectric crystal, which produces an electric signal in response to a pressure pulse. The shape of the probe determines its field of view, and the frequency of the emitted sound determines the minimal detectable object size. Generally, the probes are designed to move across the surface of the body. However, some probes are designed to be inserted through body lumens, such as the vagina or the rectum, so as to get closer to the organ being examined.

[0016] The calculation of the distance,  $d$ , is based on the speed of sound in the tissue,  $v$ , (for example, in fat 1450 m/s, in blood 1570 m/s, in skull bone 4080 m/s, while the mean value for human soft tissue is 1540 m/s, which is similar to that of water) and the time of travel,  $t$ , usually measured in microseconds. Where a single probe is used as a transmitter

and receiver, the time of travel,  $t$ , refers to the time it takes the sound signal to propagate through the tissue from the ultrasound probe to the reflecting interface and back to the ultrasound probe. Thus, in a homogeneous media, the distance may be calculated according to  $d=v t/2$ .

[0017] It will be appreciated that a predetermined offset needs to be considered, due to fixed electronic and mechanical delays. For example, in cases of measurements involving direct contact transducers, the offset compensates for transit time of the sound pulse through the transducer's wear-plate and the couplant layer, and for any electronic switching time or cable delays. The offset is determined as a part of instrument calibration procedures and is necessary for high accuracy. It will be further appreciated that when a single transducer transmits and receives, there is an additional dead time, which can be overcome by using at least two transducers, one transmitting and the other receiving.

[0018] A reflectance,  $R$ , may be defined, representing the energy that is being reflected.  $R$  depends on the impedance discontinuity between the different types of tissues across the interface, or

$$R=(Z_2-Z_1)^2/(Z_2+Z_1)^2,$$

[0019] where  $Z_1$  is the acoustic impedance of the tissue in which the ultrasound pulse travels, and  $Z_2$  is the impedance of the tissue across the interface. In general, the acoustic impedance is the product of the density of a material,  $\rho$ , and the speed of sound in that material,  $v$ , so that,

$$Z=\rho v.$$

[0020] For tissues, which are essentially water-like, so that the speed of sound in them is essentially that of the speed of sound in water, the reflectance depends on the variation in tissue density  $\rho_1$  and  $\rho_2$ , across the interface.

[0021] For example, in a human body, at ultrasound frequencies of several MHz, for example, 1-10 MHz, the density variation between fat and muscle tissue will lead to about 3% reflection because of the difference in ultrasonic impedance between the two types of tissue. Similarly, at these frequencies, a breast tumor, being denser than fat, will lead to a reflection of about 1%. Thus, the ultrasound technique is useful in identifying cancerous tumors. A radiologist may use the ultrasound imaging to guide a surgical tool, such as a biopsy needle or an incision instrument.

[0022] Before the early 1970's ultrasound imaging systems were able to record only the strong echoes arising from the outlines of an organ, but not the low-level echoes of the internal structure. Therefore liver scans, for instance, did not show possible carcinomas or other pathological states. In 1972 a refined imaging mode was introduced called gray-scale display, in which the internal texture of many organs became visible. In gray-scale display, low-level echoes are amplified and recorded together with the higher-level ones, giving many degrees of brightness. In consequence, ultrasound imaging became a useful tool for imaging tumors, for example, in the liver.

[0023] A development of recent years is a 3D ultrasound imaging, in which, several two-dimensional images are acquired by moving the probes across the body surface or by rotating probes, inserted into body lumens. The two-dimensional scans are then combined by specialized computer software to form 3D images.

[0024] In multiple-element probes, each element has a dedicated electric circuit, so that the beam can be “steered” by changing the timing in which each element sends out a pulse. Additionally, transducer-pulse controls allow the operator to set and change the frequency and duration of the ultrasound pulses, as well as the scan mode of the machine. A probe formed of array transducers has the ability to be steered as well as focused. By sequentially stimulating each element, the beams can be rapidly steered from the left to right, to produce a two-dimensional cross sectional image.

[0025] Contrast agents may be used in conjunction with ultrasound imaging, for example as taught by U.S. Pat. No. 6,280,704, to Schutt, et al., entitled, “Ultrasonic imaging system utilizing a long-persistence contrast agent,” whose disclosure is incorporated herein by reference.

[0026] A large number of techniques, other than ultrasound, are available today for tissue characterization, to determine the presence of abnormal tissue, for example, cancerous or pre-cancerous tissue. Many of these may be used with hand-held probes. Others use miniature probes that may be inserted into a body lumen or applied in minimally invasive surgery.

[0027] One of the methods used for tissue characterization is based on measurements of the tissue’s electromagnetic properties.

[0028] Commonly owned U.S. Pat. No. 6,813,515, to Hashimshony, entitled, “Method and system for examining tissue according to the dielectric properties thereof,” whose disclosure is incorporated herein by reference, describes a method and system for examining tissue in order to differentiate it from other tissue, according to the dielectric properties of the examined tissue. The method includes applying an electrical pulse to the tissue to be examined via a probe formed with an open cavity such that the probe generates an electrical fringe field in examined tissue within the cavity and produces a reflected electrical pulse therefrom with negligible radiation penetrating into other tissues or biological bodies near the examined tissue; detecting the reflected electrical pulse; and comparing electrical characteristics of the reflected electrical pulse with respect to the applied electrical pulse to provide an indication of the dielectric properties of the examined tissue.

[0029] Furthermore, commonly owned U.S. Patent Application 60/641,081, entitled, “Device and Method for Tissue Characterization in a Body Lumen, by an Endoscopic Electromagnetic Probe,” whose disclosure is incorporated herein by reference, discloses a device and method for tissue characterization in a body lumen, for the detection of abnormalities, using an electromagnetic probe, mounted on an endoscope. The endoscope may be designed for insertion in a body lumen, selected from the group consisting of an oral cavity, a gastrointestinal tract, a rectum, a colon, bronchi, a vagina, a cervix, a urinary tract, and blood vessels. Additionally, it may be designed for insertion in a tricular valve.

[0030] Electrical impedance imaging is another known imaging technique for detecting tumors. It involves systems in which the impedance between a point on the surface of the skin and some reference point on the body of a patient is determined. Sometimes, a multi-element probe, formed as a sheet with an array of electrical contacts is used, for obtain-

ing a two-dimensional impedance map of the tissue, for example, the breast. The two-dimensional impedance map may be used, possibly in conjunction with other data, such as mammography, for the detection of cancer.

[0031] Rajshekhar, V. (“Continuous impedance monitoring during CT-guided stereotactic surgery: relative value in cystic and solid lesions,” Rajshekhar, V., British Journal of Neurosurgery, 1992, 6, 439-444) describes using an impedance probe with a single electrode to measure the impedance characteristics of lesions. The objective of the study was to use the measurements made in the lesions to determine the extent of the lesions and to localize the lesions more accurately. The probe was guided to the tumor by CT and four measurements were made within the lesion as the probe passed through the lesion. A biopsy of the lesion was performed using the outer sheath of the probe as a guide to position, after the probe itself was withdrawn.

[0032] U.S. Pat. No. 4,458,694, to Sollish, et al., entitled, “Apparatus and method for detection of tumors in tissue,” whose disclosure is incorporated herein by reference, relates to an apparatus for detecting tumors in human breast, based on the dielectric constants of localized regions of the breast tissue. The apparatus includes a probe, comprising a plurality of elements. The apparatus further includes means for applying an AC signal to the tissue, means for sensing electrical properties at each of the probe elements at different times, and signal processing circuitry, coupled to the sensing means, for comparing the electrical properties sensed at the different times. The apparatus thus provides an output of the dielectric constants of localized regions of breast tissue associated with the probe.

[0033] Similarly, U.S. Pat. No. 4,291,708 to Frei, et al., entitled, “Apparatus and method for detection of tumors in tissue,” whose disclosure is incorporated herein by reference, relates to apparatus for detecting tumors in human breast tissue, by the dielectric constants of a plurality of localized regions of human breast tissue.

[0034] U.S. Pat. Nos. 6,308,097, 6,055,452 and 5,810,742, to Pearlman, A. L., entitled, “Tissue characterization based on impedance images and on impedance measurements,” whose disclosures are incorporated herein by reference, describe apparatus for aiding in the identification of tissue type for an anomalous tissue in an impedance image. The device comprises: means for providing a polychromatic emittance map of a portion of the body; means for determining a plurality of polychromatic measures from one or both of a portion of the body; and a display of an indication based on said plurality of polychromatic measures.

[0035] Another known method of tissue characterization is by optical fluorescence spectroscopy. When a sample of large molecules is irradiated, for example, by laser light, it will absorb radiation, and various levels will be excited. Some of the excited states will return back substantially to the previous state, by elastic scattering, and some energy will be lost in internal conversion, collisions and other loss mechanisms. However, some excited states will create fluorescent radiation, which, due to the distribution of states, will give a characteristic wavelength distribution.

[0036] Some tumor-marking agents give well-structured fluorescence spectra, when irradiated by laser light. In particular, hematoporphyrin derivatives (HPD), give a well-

structured fluorescence spectrum, when excited in the Soret band around 405 nm. The fluorescence spectrum shows typical peaks at about 630 and 690 nm, superimposed in practice on more unstructured tissue auto fluorescence. Other useful tumor-marking agents are dihematoporphyrin ether/ester (DHE), hematoporphyrin (HP), polyhematoporphyrin ester (PHE), and tetrasulfonated phthalocyanine (TSPC), when irradiated at 337 nm (N<sub>2</sub> laser).

[0037] U.S. Pat. No. 5,115,137, to Andersson-Engels, et al, entitled, "Diagnosis by means of fluorescent light emission from tissue," whose disclosure is incorporated herein by reference, relates to improved detection of properties of tissue by means of induced fluorescence of large molecules. The tissue character may then be evaluated from the observed large-molecule spectra. According to U.S. Pat. No. 5,115,137, the spectrum for tonsil cancer is clearly different from normal mucosa, due to endogenous porphyrins.

[0038] Similarly, U.S. Pat. No. 4,785,806, to Deckelbaum, entitled, "Laser ablation process and apparatus," whose disclosure is incorporated herein by reference, describes a process and apparatus for ablating atherosclerotic or neoplastic tissues. Optical fibers direct low power light energy at a section of tissue to be ablated to cause the section to fluoresce. The fluorescence pattern is analyzed to determine whether the fluorescence frequency spectrum is representative of normal or abnormal tissue. A source of high power, ultraviolet, laser energy directed through an optical fiber at the section of tissue is fired only when the fluorometric analysis indicates that it is directed at abnormal tissue.

[0039] Additionally, U.S. Pat. No. 4,682,594, to Mok, entitled, "Probe-and fire lasers," whose disclosure is incorporated herein by reference, describes a method and an apparatus of irradiating a treatment area within a body, such as blood vessel plaque. The method includes initially administering to the patient a non-toxic atheroma-enhancing reagent which causes the plaque to have a characteristic optical property when illuminated with a given radiation, introducing a catheter system including fiberoptic cable means into the artery such that the distal end thereof is operatively opposite the plaque site, introducing into the proximal end of the fiberoptic cable means the given radiation, photoelectrically sensing at the proximal end the characteristic optical property to generate a control signal, and directly under the control of the control signal transmitting via the cable means from the proximal end to the distal end, periodically occurring laser pulses until the characteristic optical property is no longer sensed.

[0040] U.S. Pat. No. 6,258,576, to Richards-Kortum, et al., entitled, "Diagnostic method and apparatus for cervical squamous intraepithelial lesions in vitro and in vivo using fluorescence spectroscopy," whose disclosure is incorporated herein by reference, relates to the use of multiple illumination wavelengths in fluorescence spectroscopy for the diagnosis of cancer and precancer, for example, in the cervix. In this manner, it has been possible to (i) differentiate normal or inflamed tissue from squamous intraepithelial lesions (SILs) and (ii) differentiate high grade SILs from non-high grade SILs. The detection may be performed in vitro or in vivo. Multivariate statistical analysis has been employed to reduce the number of fluorescence excitation-emission wavelength pairs needed to re-develop algorithms that demonstrate a minimum decrease in classification accu-

racy. For example, the method of the aforementioned patent may comprise illuminating a tissue sample with electromagnetic radiation wavelengths of about 337 nm, 380 nm and 460 nm, to produce fluorescence; detecting a plurality of discrete emission wavelengths from the fluorescence; and calculating from the emission wavelengths a probability that the tissue sample belongs in particular tissue classification.

[0041] Commonly owned U.S. Patent Application 2003/01383786, to Hashimshony, entitled, "Method and apparatus for examining tissue for predefined target cells, particularly cancerous cells, and a probe useful for such method and apparatus," whose disclosure is incorporated herein by reference, teaches a method apparatus and probe for examining tissue and characterizing its type according to measured changes in optical characteristics of the examined tissue. In a preferred embodiment of this method the tissue to be examined is subject to a contrast agent containing small particles of a physical element conjugated with a biological carrier selectively bindable to the target cells. Additionally, energy pulses are applied to the examined tissue, and the changes in impedance and/or the optical characteristics produced by the applied energy pulses are detected and utilized for determining the presence of the target cells in the examined tissue. Furthermore, in a preferred embodiment, the applied energy pulses include laser pulses, and the physical element conjugated with a biological carrier is a light-sensitive semiconductor having impedance which substantially decrease in the presence of light. Moreover, the same probe used for detecting the targeted cells, may also be used for destroying the cells so targeted.

[0042] Optical reflectance spectroscopy may also be used. Its application for tissue characterization is described, for example, in <http://www.sbsplimb.nichd.nih.gov/html/spectroscopy.html>, downloaded on Mar. 15, 2005. It describes an optical reflectance spectroscopy (ORS) device for measuring the thickness of the epithelial layer, and an evaluation technique based on oblique angle reflectance spectroscopy that allows assessment of the scattering and absorption properties of the epithelium and stroma, thus providing information on chronic oral epithelial tissue inflammation, which is considered a potential diagnostic precursor to oral cancer.

[0043] Another known method for tissue characterization is magnetic resonance imaging (MRI), which is based on the absorption and emission of energy in the radio frequency range of the electromagnetic spectrum, by nuclei having unpaired spins.

[0044] Conventional MRI is a large-apparatus, for whole body imaging, having:

[0045] i. a primary magnet, which produces the B<sub>0</sub> field for the imaging procedure;

[0046] ii. gradient coils for producing a gradient in B<sub>0</sub>;

[0047] iii. an RF coil, for producing the B<sub>1</sub> magnetic field, necessary to rotate the spins by 90° or 180° and for detecting the MRI signal; and

[0048] iv. a computer, for controlling the components of the MRI imager.

[0049] Generally, the magnet is a large horizontal bore superconducting magnet, which provides a homogeneous magnetic field in an internal region within the magnet. A

patient or object to be imaged is usually positioned in the homogeneous field region located in the central air gap for imaging. A typical gradient coil system comprises an anti-Helmholtz type of coil. These are two parallel ring shaped coils, around the z axis. Current in each of the two coils flows in opposite directions creating a magnetic field gradient between the two coils.

[0050] The RF coil creates a B1 field, which rotates the net magnetization in a pulse sequence. The RF coils may be: 1) transmit and receive coils, 2) receive only coils, and 3) transmit only coils.

[0051] As described hereinabove, the MRI relies on a magnetic field in an internal region within the magnet. As such, it is unsuitable as a handheld probe or an endoscopic probe, because the tissue to be imaged has to be in the internal region of the imager,

[0052] This problem has been resolved by U.S. Pat. No. 5,572,132, to Pulyer, et al., entitled, "MRI probe for external imaging," whose disclosure is incorporated herein by reference, which describes an MRI spectroscopic probe having an external background magnetic field B0 (as opposed to the internal background magnetic field of the large horizontal bore superconducting magnet.). Thus, an MRI catheter for endoscopic imaging of tissue of the artery wall, rectum, urinal tract, intestine, esophagus, nasal passages, vagina and other biomedical applications may be constructed. The probe comprises (i) a miniature primary magnet having a longitudinal axis and an external surface extending in the axial direction, and (ii) a RF coil surrounding and proximal to said surface. The primary magnet is structured and configured to provide a symmetrical, preferably cylindrically shaped, homogeneous field region external to the surface of the magnet. The RF coil receives NMR signals from excited nuclei. For imaging, one or more gradient coils are provided to spatially encode the nuclear spins of nuclei excited by an RF coil, which may be the same coil used for receiving NMR signals or another RF coil.

[0053] Additionally, commonly owned US Patent Application 2005/0021019 to Hashimshony et al., entitled "Method and apparatus for examining substance, particularly tissue, to characterize its type," whose disclosure is incorporated herein by reference, describes a method and apparatus for examining a substance volume to characterize its type, by: applying a polarizing magnetic field through the examined substance; applying RF pulses locally to the examined substance volume such as to invoke electrical impedance (EI) responses signals corresponding to the electrical impedance of the substance, and magnetic resonance (MR) responses signals corresponding to the MR properties of the substance; detecting the EI and MR response signals; and utilizing the detected response signals for characterizing the examined substance volume type.

[0054] Contrast agents may be used in conjunction with MRI. For example, U.S. Pat. No. 6,315,981 to Unger, entitled, "Gas filled microspheres as magnetic resonance imaging contrast agents," whose disclosure is incorporated herein by reference, describes the use of gas filled microspheres as contrast agents for MRI.

[0055] Temperature imaging for locating and detecting neoplastic tissue is also known. In the 1950's, it was discovered that the surface temperature of skin in the area of

a malignant tumor exhibited a higher temperature than that expected of healthy tissue. Thus, by measuring body skin temperatures, it became possible to screen for the existence of abnormal body activity such as cancerous tumor growth. With the development of liquid crystals and methods of forming temperature responsive chemical substrates, contact thermometry became a reality along with its use in medical applications. Devices employing contact thermometry could sense and display temperature changes through indicators which changed colors, either permanently or temporarily, when placed in direct physical contact with a surface such as skin, reflecting a temperature at or near the point of contact. An abnormal reading would alert a user to the need for closer, more detailed examination of the region in question. However, the art in this area has been directed primarily at sensing and displaying temperatures on exterior skin surfaces. Thus, for example, U.S. Pat. No. 3,830,224, to Vanzetti et al., whose disclosure is incorporated herein by reference, disclosed the placement of temperature responsive, color changing liquid crystals at various points in a brassiere for the purpose of detecting the existence of breast cancer, while U.S. Pat. No. RE 32,000, to Sagi, entitled, "Device for Use in Early Detection of Breast Cancer," whose disclosure is incorporated herein by reference, disclosed the use of radially arranged rows of temperature responsive indicators, deposited on a disc for insertion into the breast-receiving cups of a brassiere for the same purpose.

[0056] U.S. Pat. No. 6,135,968, to Brounstein, entitled, "Differential temperature measuring device and method", whose disclosure is incorporated herein by reference, describes a device and method for sensing temperatures at internal body locations non-surgically accessible only through body orifices. The device is particularly useful in medical applications such as screening for cancer and other abnormal biological activity signaled by an increase in temperature at a selected site. As applied to prostate examinations, the device is temporarily, adhesively affixed to a user's fingertip or to a mechanical probe. In the preferred embodiment, the device includes two temperature-sensing elements, which may include a plurality of chemical indicators. Each indicator changes color in response to detection of a predetermined particular temperature. When properly aligned and installed, the first element is located on the palmar surface of the fingertip while the second element is located on the dorsal surface of the fingertip. After an examination glove has been donned over the fingertip carrying the device, a prostate examination is performed during which the first element is brought into constant but brief contact with the prostate region and the second element is similarly, simultaneously brought into contact with a dermal surface opposing the prostate region. Upon withdrawal of the fingertip from the rectum and removal of the glove, the two temperature sensing elements may be visually examined in order to determine the temperatures detected by each one. A significant difference in observed temperatures indicates the possibility of abnormal biological activity and the need for further diagnostic or medical procedures.

[0057] Infrared thermography is a temperature imaging technique, which measures thermal energy emitted from the body surface without contact, quickly and dynamically, and produces a temperature image for analysis. Harzbecker K, et al. report, based on thermic observations in 63 patients and a control experiment in 15 persons, on experiences with thermography in the diagnosis of diseases, which are local-

ized more profoundly in the thoracic cavity. (Harzbecker K, et al., "Thermographic thorax diagnostics," *Z Gesamte Inn Med.* Feb. 1, 1978;33(3):78-80.)

[0058] Similarly, Dexter L I, Kondrat'ev V B. report data concerning the use of lymphography and thermography for the purpose of establishing a differential diagnosis in 42 patients with edema of the lower limbs of a different origin. A comparative estimation of different methods of the differential diagnosis indicated the advantages of infrared thermography. (Dexter L I, Kondrat'ev V B., "Thermography in differential diagnosis of lymphostasis in the lower limbs," *Vestn Khir Im II Grek.* June 1976; 116(6):60-4.)

[0059] Various means for minimally invasive surgical removal, of a breast tumor and other tumors in a soft tissue are known.

[0060] For example, U.S. Pat. No. 6,375,634, to Carroll, entitled, apparatus and method to encapsulate, kill and remove malignancies, including selectively increasing absorption of x-rays and increasing free-radical damage to residual tumors targeted by ionizing and non-ionizing radiation therapy", whose disclosure is incorporated herein by reference, describes a coaxial bipolar needle electrode for applying radio-frequency diathermal heat.

[0061] U.S. Pat. No. 6,840,948 to Albrecht, et al. entitled, "Device for removal of tissue lesions," whose disclosure is incorporated herein by reference, describes an excisional biopsy device and method for excision and removal of neoplasms under real-time image guidance with minimal disruption of normal tissue while providing an optimal specimen to assess the completeness of the excision. The device and method are minimally invasive, and are used to remove cancerous lesions from soft tissue, including breast tissue, and are a less invasive alternative to open lumpectomy. The invention provides an RF loop for excision and removal of breast lesions which promotes hemostasis during excision through electrosurgical coagulation of blood vessels and channels to supply pressure and hemostatic fluids to the tissue cavity.

[0062] The method includes is as follows: The mass is localized, and the tunneling trajectory is determined. The skin is excised, and tunneling is begun by activating and using the semi-circular RF tunneling electrode. After tunneling is completed, but prior to cutting a sphere, the coordinates of the excision specimen are confirmed, preferably with the assistance of computer aided imaging and guidance technology. The semi-circular rotational electrode blade of the RF loop is then activated and used to cut the sphere, and is rotated by the drive electrical cables attached to the power drive. Simultaneously, the tissue is immobilized and any blood is aspirated by vacuum. As the RF loop is rotated, it pulls along the containment sheath or bag that surrounds the spherical specimen. After the sphere is fully cut, the RF loop is held in place and the containment sheath is pulled taught around the sphere by a draw cord to reduce the sphere's volume to aid in its removal. The device and sphere are then removed from the body simultaneously.

[0063] US Patent Application 20020120265, to Fowler, entitled, "Symmetric conization electrocautery device," whose disclosure is incorporated herein by reference, describes a tissue electrocautery device that accommodates anatomical structures lying at more than one longitudinal

axes. Such a circumstance is encountered when attempting to perform symmetric tissue electrocautery of an endocervical canal where the longitudinal axis of the vaginal vault is at an angle to the longitudinal axis of the endocervical canal. The device of the present invention uses a hollow housing, elongate along a first longitudinal axis, having a proximal portion with a proximal end and a distal end, and includes a distal portion from the distal end. The distal portion is elongate along a second longitudinal axis and pivotable in relation to the proximal portion at a selectable angle to the first longitudinal axis. Within the housing is a rotatable electrically conducting mechanism, adapted to conduct electrocautery energy from an electrode proximal to the housing proximal portion to a coupling proximate the distal portion, while rotating the coupling with a removable handle proximal to the housing proximal portion. The electrical energy is delivered to an electrocautery head, carrying an electrocautery wire, operably electrically engageable with the coupling and rotatable around a longitudinal axis parallel the second longitudinal axis, electrocauterizing tissue of a human patient s while rotating around its longitudinal axis.

[0064] In spite of these works, clean removal of malignancies, surrounded by definite and sufficient clean margins, remains an elusive goal.

#### SUMMARY OF THE INVENTION

[0065] The present invention provides a hand-held, integrated tool, having a tissue-type sensor, for determining the tissue type at a near zone volume of a tissue surface, and a distance-measuring sensor, for determining the distance to an interface with another tissue type. The tool is operable for (i) confirming an existence of a clean margin of healthy tissue around a malignant tumor, which is being removed, and (ii) determining the width of the clean margin, wherein both are performed in real time, while the malignant tumor is being removed. The tissue-type sensor may be selected from the group of a sensor for tissue electromagnetic properties, a dielectric sensor, an impedance sensor, a sensor for optical fluorescence spectroscopy, a sensor for optical reflectance spectroscopy, an MRI sensor, an RF sensor, an MW sensor, a temperature sensor, and infrared thermography sensor, or another tissue-characterization sensor, as known. The distance-measuring sensor may be an ultrasound transducer, an MRI probe, an invasive needle with a strain or pressure gauge, or another tissue distance measuring sensor, as known. The integrated tool may further include a position tracking device and an incision instrument. The soft tissue may be held within a fixed frame, while the tumor is being removed. Additionally a method for malignant tumor removal is provided, comprising, fixing the soft tissue within a frame, performing imaging with the hand-held, integrated tool, from a plurality of locations and orientations around the soft tissue, reconstructing a three-dimensional image of the soft tissue and the tumor within, defining a desired clean margin on the reconstructed image, calculating a recommended incision path, displaying the recommended path on the reconstructed image, and cutting the tissue while determining its type, at the near zone volume of the incision surface, by the hand-held integrated tool. The method may further include continuously imaging with the cutting, continuously correcting the reconstructed

image and the recommended incision path, and continuously determining the tissue type, at the near zone volume of the incision surface.

[0066] In accordance with one aspect of the present invention, there is provided an integrated tool, for clean-margin assessment, comprising:

[0067] a structure, which defines a proximal end with respect to a tissue and which is adapted for placement proximally to the tissue;

[0068] a tissue-type sensor, mounted on the structure, for determining a tissue type at a near zone volume of a tissue surface; and

[0069] a distance-measuring sensor, mounted on the structure, for determining a distance between the tissue surface and an interface with another tissue type,

[0070] wherein the integrated tool is configured as a hand-held tool.

[0071] In accordance with an additional aspect of the present invention, the another tissue type is a cancerous tissue, and the integrated tool may be used to assess:

[0072] whether the tissue type at the near zone volume of the tissue surface is healthy; and

[0073] the distance between the tissue surface and an interface with the cancerous tissue.

[0074] In accordance with an additional aspect of the present invention, the integrated tool is adapted for operation in tandem with a surgical tool, for a real-time correction of a clean margin, where necessary.

[0075] In accordance with an additional aspect of the present invention, the integrated tool includes an incision instrument, integrated therewith, for a real-time correction of a clean margin, where necessary.

[0076] In accordance with an additional aspect of the present invention, the incision instrument may be selectively retracted and selectively deployed.

[0077] In accordance with an additional aspect of the present invention, the incision instrument is a diathermic incision instrument.

[0078] In accordance with an additional aspect of the present invention, the tissue-type sensor is selected from the group consisting of a sensor for tissue electromagnetic properties, a dielectric sensor, an impedance sensor, a sensor for optical fluorescence spectroscopy, a sensor for optical reflectance spectroscopy, an MRI sensor, an RF sensor, an MW sensor, a temperature sensor, and infrared thermography sensor.

[0079] In accordance with an additional aspect of the present invention, the tissue-type sensor is a dielectric-property sensor, formed substantially as a coaxial cable.

[0080] In accordance with an additional aspect of the present invention, the tissue surface is selected from the group consisting of a skin, a tissue lumen, and an incision surface.

[0081] In accordance with an additional aspect of the present invention, the distance-measuring sensor is an ultrasound transducer.

[0082] In accordance with an additional aspect of the present invention, the distance-measuring sensor is formed of two ultrasound transducers.

[0083] In accordance with an additional aspect of the present invention, the distance-measuring sensor is formed of an array of ultrasound transducers, which may be selectively steered.

[0084] In accordance with an additional aspect of the present invention, the distance-measuring sensor is selected from the group consisting of a strain gauge and a pressure sensor.

[0085] In accordance with an additional aspect of the present invention, the distance-measuring sensor is an MRI probe.

[0086] In accordance with an additional aspect of the present invention, the integrated tool is operative with a guide wire, wherein a proximal tip of the guide wire, with respect to the tissue, is placed within the another tissue type.

[0087] In accordance with an alternative aspect of the present invention, the integrated tool is operative with a guide wire, wherein a proximal tip of the guide wire, with respect to the tissue, is placed in close proximity with the another tissue type.

[0088] In accordance with an additional aspect of the present invention, the integrated tool is operative with a guide wire, wherein the distance-measuring sensor is an ultrasound transducer, and the guide wire further includes a guide wire ultrasound transducer, at a proximal tip thereof, with respect to the tissue, for emitting ultrasound signals, indicative of the proximal-tip distance from the integrated tool.

[0089] In accordance with an additional aspect of the present invention, the integrated tool is operative with a guide wire, wherein the distance-measuring sensor is an ultrasound transducer, and the guide wire further includes a guide wire ultrasound transducer, at a proximal tip thereof, with respect to the tissue, for emitting ultrasound signals, indicative of the proximal-tip position with respect to the integrated tool, by triangulation.

[0090] In accordance with an additional aspect of the present invention, the integrated tool includes a position-tracking device.

[0091] In accordance with an additional aspect of the present invention, the position-tracking device is correlated with a coordinate system of a fixed frame, within which, the tissue is held fixed in place.

[0092] In accordance with another aspect of the present invention, there is provided a system for clean-margin assessment, comprising:

[0093] a hand-held, integrated tool, for clean-margin assessment, which comprises:

[0094] a structure, which defines a proximal end with respect to a tissue and which is adapted for placement proximally to the tissue;

[0095] a tissue-type sensor, mounted on the structure, for determining a tissue type at a near zone volume of a tissue surface; and

- [0096] a distance-measuring sensor, mounted on the structure, for determining a distance between the tissue surface and an interface with another tissue type;
- [0097] a computerized system, which comprises:
- [0098] a tissue-type-sensor analyzer, associated with the tissue-type sensor;
- [0099] a distance-measuring-sensor analyzer, associated with the distance-measuring sensor;
- [0100] an output device, which provides output of measurements by the tissue-type sensor and the distance-measuring sensor.
- [0101] In accordance with an additional aspect of the present invention, the system includes a fixed frame for holding the tissue therein.
- [0102] In accordance with an additional aspect of the present invention, the system includes a position-tracking device and a position-tracking-device analyzer.
- [0103] In accordance with an additional aspect of the present invention, the system includes a computer.
- [0104] In accordance with yet another aspect of the present invention, there is provided a system for clean-margin assessment, comprising:
- [0105] a fixed frame for holding a tissue therein, the frame defining a coordinate system;
- [0106] a hand-held, integrated tool, for clean-margin assessment, which comprises:
- [0107] a structure, which defines a proximal end with respect to the tissue and which is adapted for placement proximally to the tissue;
- [0108] a tissue-type sensor, mounted on the structure, for determining a tissue type at a near zone volume of a tissue surface;
- [0109] an imager, operative as a distance-measuring sensor, mounted on the structure, for determining a distance between the tissue surface and an interface with another tissue type; and
- [0110] a position-tracking device, mounted on the structure and correlated with the coordinate system;
- [0111] a computerized system, which comprises:
- [0112] a tissue-type-sensor-analyzer, associated with the tissue-type sensor;
- [0113] a distance-measuring-sensor analyzer, associated with the distance-measuring sensor;
- [0114] a position-tracking-device analyzer, associated with the position-tracking device;
- [0115] a computer, for receiving data from the tissue-type-sensor analyzer, the distance-measuring-sensor analyzer, and the position-tracking-device analyzer, and performing analysis thereof;
- [0116] an output device, associated with the computer.
- [0117] In accordance with still another aspect of the present invention, there is provided a method of clean-margin assessment, comprising:
- [0118] providing a hand-held, integrated tool, for clean-margin assessment, which comprises:
- [0119] a structure, which defines a proximal end with respect to a tissue and which is adapted for placement proximally to the tissue;
- [0120] a tissue-type sensor, mounted on the structure, for determining a tissue type at a near zone volume of a tissue surface; and
- [0121] a distance-measuring sensor, mounted on the structure, for determining a distance between the tissue surface and an interface with another tissue type;
- [0122] determining the tissue type at the near zone volume of the tissue surface; and
- [0123] determining the distance between the tissue surface and the interface with the another tissue type.
- [0124] In accordance with yet another aspect of the present invention, there is provided a method of clean-margin assessment, comprising:
- [0125] providing a hand-held, integrated tool, for clean-margin assessment, which comprises:
- [0126] a structure, which defines a proximal end with respect to a tissue and which is adapted for placement proximally to the tissue;
- [0127] a tissue-type sensor, mounted on the structure, for determining a tissue type at a near zone volume of a tissue surface; and
- [0128] a non-invasive imager, mounted on the structure; and
- [0129] a position-tracking device, mounted on the structure;
- [0130] fixing the tissue within a fixed frame, which defines a coordinate system;
- [0131] imaging the tissue, from at least two locations and orientations, by the hand-held, integrated tool;
- [0132] reconstructing a three dimensional image of the tissue;
- [0133] displaying the three dimensional image of the tissue;
- [0134] defining a desired clean margin around another tissue type;
- [0135] displaying the desired clean margin;
- [0136] calculating a recommended incision path;
- [0137] displaying the recommended incision path;
- [0138] providing an incision instrument;
- [0139] cutting along the recommended incision path; and
- [0140] determining the tissue type at the near zone volume of the tissue surface, by the hand-held, integrated tool.
- [0141] In accordance with an additional aspect of the present invention, the method includes:
- [0142] continuously imaging the tissue, from different locations and orientations along the tissue surface, by the hand-held, integrated tool;

[0143] continuously correcting the recommended incision path; and

[0144] continuously displaying the continuously corrected recommended incision path.

[0145] In accordance with an additional aspect of the present invention, the method includes continuously determining the tissue type, at the near zone volume of the incision surface, by the hand-held, integrated tool.

[0146] Unless otherwise defined, all technical and scientific terms used herein have the same meaning as commonly understood by one of ordinary skill in the art to which this invention belongs. Although methods and materials similar or equivalent to those described herein can be used in the practice or testing of the present invention, suitable methods and materials are described below. In case of conflict, the patent specification, including definitions, will control. In addition, the materials, methods, and examples are illustrative only and not intended to be limiting.

#### BRIEF DESCRIPTION OF THE DRAWINGS

[0147] The invention is herein described, by way of example only, with reference to the accompanying drawings. With specific reference now to the drawings in detail, it is stressed that the particulars shown are by way of example and for purposes of illustrative discussion of the preferred embodiments of the present invention only, and are presented in the cause of providing what is believed to be the most useful and readily understood description of the principles and conceptual aspects of the invention. In this regard, no attempt is made to show structural details of the invention in more detail than is necessary for a fundamental understanding of the invention, the description taken with the drawings making apparent to those skilled in the art how the several forms of the invention may be embodied in practice.

[0148] In the drawings:

[0149] **FIGS. 1a-1f** schematically illustrate the application of an integrated tool for clean-margin assessment to a soft tissue that contains a cancerous tissue within and the principles of clean-margin assessment, in accordance with the present invention;

[0150] **FIGS. 2a-2c** schematically illustrate an isometric view, a frontal view, and a cross-sectional view of the integrated tool for clean-margin assessment, in accordance with the present invention;

[0151] **FIG. 3** schematically illustrates an ultrasound distance-measuring sensor of the integrated tool for clean-margin assessment, in accordance with the present invention;

[0152] **FIGS. 4a-4d** further illustrate the operational manner of the integrated tool for clean-margin assessment, in accordance with the present invention;

[0153] **FIGS. 5a-5c** further illustrate the operational manner of the integrated tool for clean-margin assessment, in accordance with the present invention;

[0154] **FIG. 6** schematically illustrates an overall system for clean-margin assessment, in accordance with the present invention;

[0155] **FIGS. 7a-7d** schematically illustrate the integrated tool for clean-margin assessment, which further includes a retractable knife, in accordance with a preferred embodiment of the present invention;

[0156] **FIGS. 8a-8b** schematically illustrate the integrated tool for clean-margin assessment, operative with a frame for fixing a soft tissue, in accordance with a preferred embodiment of the present invention;

[0157] **FIGS. 9a and 9b** schematically illustrate the integrated tool for clean-margin assessment, wherein the tissue-type sensor is formed as a horn antenna, for RF or MW, in accordance with still another embodiment of the present invention;

[0158] **FIGS. 10a and 10b** schematically illustrate the integrated tool for clean-margin assessment, wherein the tissue-type sensor is formed as an optical sensor, in accordance with yet another embodiment of the present invention;

[0159] **FIGS. 11a and 11b** schematically illustrate the integrated tool for clean-margin assessment, wherein the tissue-type sensor is formed as an MRI sensor, in accordance with yet another embodiment of the present invention;

[0160] **FIGS. 12a and 12b** schematically illustrate the integrated tool for clean-margin assessment, wherein the distance-measuring sensor is formed as a strain gauge, in accordance with still another embodiment of the present invention;

[0161] **FIGS. 13a and 13b** schematically illustrate the integrated tool for clean-margin assessment, wherein the distance-measuring sensor is formed as a pressure sensor, in accordance with still another embodiment of the present invention; and

[0162] **FIGS. 14a and 14b** illustrate, in flowchart forms, surgical methods of tumor removal, using the integrated tool for clean-margin assessment, in accordance with embodiments of the present invention.

#### DESCRIPTION OF THE PREFERRED EMBODIMENTS

[0163] The present invention is of an integrated tool, having a tissue-type sensor, for determining the tissue type at a near zone volume of a tissue surface, and a distance-measuring sensor, for determining the distance to an interface with another tissue type. The tool is operable for (i) confirming an existence of a clean margin of healthy tissue around a malignant tumor, which is being removed, and (ii) determining the width of the clean margin, wherein both are performed in real time, while the malignant tumor is being removed. The tissue-type sensor may be selected from the group of a sensor for tissue electromagnetic properties, a dielectric sensor, an impedance sensor, a sensor for optical fluorescence spectroscopy, a sensor for optical reflectance spectroscopy, an MRI sensor, an RF sensor, an MW sensor, a temperature sensor, and infrared thermography sensor, or another tissue-characterization sensor, as known. The distance-measuring sensor may be an ultrasound transducer, an MRI probe, an invasive needle with a strain or pressure gauge, or another tissue distance measuring sensor, as known. The integrated tool may further include a position tracking device and an incision instrument. The soft tissue may be held within a fixed frame, while the tumor is being

removed. Additionally a method for malignant tumor removal is provided, comprising, fixing the soft tissue within a frame, performing imaging with the hand-held, integrated tool, from a plurality of locations and orientations around the soft tissue, reconstructing a three-dimensional image of the soft tissue and the tumor within, defining a desired clean margin on the reconstructed image, calculating a recommended incision path, displaying the recommended path on the reconstructed image, and cutting the tissue while determining its type, at the near zone volume of the incision surface, by the hand-held integrated tool. The method may further include continuously imaging with the cutting, continuously correcting the reconstructed image and the recommended incision path, and continuously determining the tissue type, at the near zone volume of the incision surface.

[0164] Before explaining at least one embodiment of the invention in detail, it should be understood that the invention is not limited in its application to the details of construction and the arrangement of the components set forth in the following description or illustrated in the drawings. The invention is capable of other embodiments or of being practiced or carried out in various ways. Also, it is to be understood that the phraseology and terminology employed herein is for the purpose of description and should not be regarded as limiting.

[0165] Referring now to the drawings, FIGS. 1a-1f schematically illustrate the principles of clean margin assessment and the application of a hand-held, integrated tool 10 for clean-margin assessment, in accordance with the present invention.

[0166] The principles of clean margin assessment may be understood using the examples of FIGS. 1a-1d. These illustrate tissue portions 15 which have been removed from the body. These portions include a first tissue type of healthy tissue 14, enclosing or partly enclosing a second tissue type of cancerous or otherwise abnormal tissue 16. A tissue surface 18, which is generally the incision surface, bounds each of the tissue portions 15.

[0167] However, it will be appreciated that the tissue surface 18 may be a skin, a body lumen, or an incision surface.

[0168] As seen in FIG. 1a, the incision surface 18 has a positive margin 27 at a location 19. This means that cancerous or otherwise abnormal cells have reached the surface 18 or the near zone volume of the surface 18, at the location 19. This may happen when the incision was performed right through the cancerous or abnormal second tissue type 16. Alternatively, this may happen when the incision is performed at the interface between the first and second tissue types, 14 and 16.

[0169] The near zone at the tissue surface 18 is at least one cell layer in thickness, and preferably several cell layers in thickness. In practice, it may range from about 100 microns to about 500 microns.

[0170] Thus, the positive margin 27 may be defined as a situation where the tissue surface 18, or the near zone at the tissue surface 18, contains at least one cancerous cell.

[0171] FIG. 1a further illustrates a clean margin at a location 17, where the tissue surface 18, or the near zone at the tissue surface 18, contains no cancerous cells, and thus has a clean margin 24.

[0172] FIG. 1b illustrates another example of the positive margin 27, this time at the location 17. The positive margin of FIG. 1b, however, is due to a shoot 29, which stems from the second tissue type 16 and which reaches to the surface 18.

[0173] By contrast, FIGS. 1c and 1d illustrate examples of tissue portions 15 that have been excised with clean margins 24, at all locations.

[0174] FIG. 1e illustrates a model for clean margin assessment, showing the second, cancerous tissue type 16 and a layer of a tissue 13, surrounding it. The tissue 13 may be a healthy tissue, but may be partly cancerous or otherwise abnormal. The aim in characterizing the tissue surface 18 is to determine the type of the tissue 13 at various locations along the surface 18. Additionally, when the tissue surface 18 is characterized as the clean margin 24, a depth 25 to an interface 22 with the second tissue type 16, may be defined. While a sufficient depth may be realized when the depth 25 is only 1 cell layer in thickness, or about 40 microns, it is generally desired that the depth 25 be between about 0.1 and 10 mm.

[0175] It will be appreciated that other dimensions for the depth 25 of the clean margin may be desired and may depend on the size and type of the cancerous tumor, forming the second tissue type 16.

[0176] During a surgical operation, for the removal of a cancerous tumor, in a breast for example, it is important to ensure that the incision is made through a healthy tissue, so that all the cancerous tissue is completely contained within the healthy tissue that is being removed. Thus, the indicated need is to remove the tissue portion 15, such that:

[0177] i. the cut is made through the first tissue type 14 of healthy tissue, so as to completely contain the second tissue type 16 within;

[0178] ii. the depth 25 of the clean margin 24 of the first tissue type 14 is sufficient.

[0179] In accordance with the present invention, as illustrated by FIG. 1f, this indicated need is fulfilled by the hand-held, integrated tool 10 for clean-margin assessment, by:

[0180] i. a first sensor for characterizing the near zone volume of the tissue surface 18, to ensure that it is of the first tissue type 14 of healthy tissue; and

[0181] ii. a second sensor for measuring the depth 25 of the clean margin 24, to verify that there is sufficient depth between the tissue surface 18 and the interface 22, which bounds the second tissue type 16.

[0182] It is important to note that either sensor alone would be insufficient for the task, since it would not give sufficient information about both the character of the near zone volume of the tissue surface and the depth of the clean margin. The prior art for example, includes methods for determining the depth of the margin but lacks the ability to characterize the tissue of which the margin is formed, so as to ensure that the margin which is measured is clean. It is by this aspect, of both characterizing the tissue of the margin and measuring its depth, that the present invention overcomes the shortcomings of prior art configurations.

[0183] FIG. 1*f* further illustrates the application of the hand-held, integrated tool 10 for clean-margin assessment, to a tissue 12. The tissue 12 includes the healthy tissue, which forms the first tissue type 14. Additionally, the tissue 12 includes the cancerous or otherwise abnormal tissue, which forms the second tissue type 16, enclosed within the first tissue type 14.

[0184] In the example of FIG. 1*f*, the integrated tool 10 determines that a distance 20 between the tissue surface 18 and the interface 22, which bounds the second tissue type 16, is about twice as much as the desired depth 25 of the clean margin 24. In that case, a surgeon may decide to approach the second tissue type 16 further, in order to keep the size of the portion for removal minimal.

[0185] It will be appreciated that the integrated tool 10 may be further used to characterize additional tissue types and determine the distances between their interfaces. The various tissue types may include bone tissue, fat tissue, muscle tissue, cancerous tissue, or blood clot tissue.

[0186] Referring further to the drawings, FIGS. 2*a-2c* schematically illustrate an isometric view, a proximal view, with respect to the tissue 12, and a cross-sectional view of the integrated tool 10 for clean-margin assessment, in accordance with a first embodiment of the present invention.

[0187] The integrated tool 10 has a proximal end 30 and a distal end 32, with respect to the surface 18 (FIG. 1). In accordance with the preferred embodiment of the present invention, a tissue-type sensor 33 determines the characteristics of the tissue in the near zone volume of the surface 18, for example, whether fat, muscle, bone, healthy, cancerous, or otherwise abnormal. Additionally, a distance-measuring sensor 38 measures the distance 20 from the surface 18 to the interface 22 with the second tissue type 16.

[0188] In accordance with the first embodiment of the present invention, the tissue-type sensor 33 measures the electrical properties of the tissue type 13. By comparing the results with known tissue properties, the characteristic of the tissue type 13 is determined.

[0189] For example, the tissue-type sensor 33 may be constructed as a coaxial cable 44, having an inner electrode 34 and an outer electrode 36, which together form the sensor 33. The outer electrode 36 may be grounded.

[0190] Further in accordance with the first embodiment of the present invention, the distance-measuring sensor 38 is at least one ultrasound transducer 38.

[0191] Preferably, the coaxial cable 44 is located within an overall structure 45. The distance-measuring sensor 38, such as the at least one ultrasound transducer 38 is also mounted on the structure 45, for example, along side the tissue-type sensor 33.

[0192] Additionally, the distance-measuring sensor 38 may be formed of at least two ultrasound transducers 38, one operating as a transmitter and the other as a receiver. The advantage there is that the instrumentation dead time is shorter.

[0193] Furthermore, the distance-measuring sensor 38 may be formed as an array of ultrasound transducers 38, for providing steering and focusing capabilities, as known.

[0194] Signals from the tissue-type sensor 33 and the distance-measuring sensor 38 are transferred for analysis through a cable 46 to a computerized system 95, described hereinbelow in conjunction with FIG. 6.

[0195] Preferably, the inner electrode 34 has a diameter 40 of between about 0.2 and 1.5 mm, and the outer electrode 36 has an inner diameter 42 of between about 3.0 and 10.0 mm, and is about 0.5 mm thick. Additionally, the outer electrode 36 is covered with an insulating sheath 49 made of an insulating material, for example, Teflon. It will be appreciated that other dimensions, which may be larger or smaller, may similarly be used. The sensors 38 and 33 may be encased in a filler material 39, for example epoxy, which may be formed as a plug that fits into the structure 45, for example, as shown in FIG. 2*c*.

[0196] Preferably, the ultrasound transducer 38 operates at a frequency range of between about 0.5 MHz and about 40 MHz. It has an accuracy of about 3 mm, when operating at the lower range of 0.5 MHz, and an accuracy of about 40 micron, when operating at the higher range of 40 MHz.

[0197] The integrated tool 10 may further include a position-tracking device 50, for example, the miniBIRD® 500 or the miniBIRD® 800, which are miniaturized magnetic tracking systems having six degrees of freedom and using sensors, which are merely 5 mm wide, produced by Ascension Technology Corporation, P.O. Box 527 Burlington, Vt. 05402, USA. They are described in <http://www.ascension-tech.com/products/minibird.php>, downloaded on Mar. 15, 2005. The position-tracking device 50 may provide the coordinates of the ultrasound measurements, thus enabling a three-dimensional image reconstruction of the ultrasound.

[0198] Referring further to the drawings, FIG. 3 schematically illustrates the ultrasound distance-measuring sensor 38 of the integrated tool 10, in operation, in accordance with the present invention.

[0199] For operation, the proximal end 30 of the integrated tool 10 is brought proximally to the tissue surface 18, of the tissue 12, so as to make contact or near contact with it. The tissue 12 includes the first tissue type 14 of healthy tissue, preferably at the outer portion thereof, and the second tissue type 16 of abnormal tissue, enclosed by the first tissue type 14 of healthy tissue, with tissue 13, which is suspicious as possibly containing cancerous or otherwise abnormal tissue, surrounding the second tissue type 16. Preferably, tissue 16 is bounded by the interface 22.

[0200] Preferably, at least two ultrasound transducers 38 are used, 38A and 38B, wherein the transducer 38A is a transmitter for transmitting an ultrasound wave 58, and the transducer 38B is the receiver, for receiving an ultrasound echo 60, from the interface 22 within the tissue 12. In this manner, instrumentation dead time is reduced.

[0201] Preferably, the ultrasound sensor 38 is preset for a focal distance of about 5 mm, which is the desired depth 25 of the clean margin 24, thus providing the most accurate results for this distance.

[0202] FIG. 3 further illustrates the structure 45 of the coaxial cable 44 and the tissue-type sensor 33. Additionally, the position-tracking device 50 is shown. When correlated with a tissue coordinate system 54, illustrated hereinbelow, in conjunction with FIG. 6, it may be used together with the

ultrasound sensor 38, to provide a three-dimensional image of the tissue 12 and the abnormal tissue type 16 within.

[0203] The cable 46 carries the measurements to the computerized system 95, described hereinbelow in conjunction with FIG. 6.

[0204] Referring further to the drawings, FIGS. 4a-4d further illustrate the operational manner of the integrated tool 10 for clean-margin assessment, in accordance with the present invention.

[0205] Generally, to localize the tumor within the breast, a radiologist may place a guide wire under x-ray or ultrasound guidance, so that the proximal tip of the guide wire, with respect to the tissue, is in the tumor. Alternatively, an imaging modality alone, for example, mammography, CT, ultrasound, or another imaging modality may be used to locate the tumor. The patient is then transported to the operating room, where the surgeon uses the guide wire, or the image, or palpation to locate the tumor in the breast and to excise a portion of tissue including the cancerous portion and a layer of healthy tissue surrounding the cancerous portion. The process of inserting a guide wire is termed, pre-procedure.

[0206] In accordance with the present invention, two methods are possible, without pre-procedure, as illustrated in FIGS. 4a-4c, and with pre-procedure, as illustrated in FIG. 4d.

[0207] Thus, FIGS. 4a-4c schematically illustrate the use of the integrated tool 10 when no guide wire is used.

[0208] As seen in FIG. 4a, the integrated tool 10 may be used on the tissue surface 18, during the removal of the portion 15, to verify that the cutting proceeds as planned. At this stage, the near zone volume of the surface 18 should be detected by the tissue type sensor 33 to be of the first tissue type 14 of healthy tissue, and the interface 22 with the second tissue type 16 should be detected at the desired depth 25. Corrections can be made in real time.

[0209] As seen in FIG. 4b, the integrated tool 10 may be used on the tissue surface 18, after the removal of the portion 15, to verify that the all the cancerous tissue has been eliminated. At this stage, the near zone volume of the surface 18 should be detected by the tissue type sensor 33 to be of the first tissue type 14 of healthy tissue, and no interface 22 and no second tissue type 16 should be detected. As seen in FIG. 4b, where a portion 72 of the second tissue type 16 remained, the integrated tool 10 will identify it both by the character of the near zone volume of the tissue surface 18 around the portion 72, and by the presence of the interface 22, in back of the second tissue type 16, indicating that two types of tissue remained.

[0210] As seen in FIG. 4c, the integrated tool 10 may be used on the tissue surface 18, of the removed portion 15, after removal. This, to verify that the all the cancerous tissue is surrounded by the clean margin 24 of the first tissue type 14 of healthy tissue, and of sufficient depth 25. At this stage, the near zone volume of the surface 18 should be of the first tissue type 14, and the interface 22 should be detected at the desired depth 25.

[0211] Additionally, as seen in FIG. 4c, where there is no clean margin, as shown by a surface 74, the integrated tool 10 will identify it both by the character of the near zone

volume of the tissue surface 18 at the surface 74, and by the absence of the interface 22, around the desired depth 25.

[0212] FIG. 4d schematically illustrates the use of the integrated tool 10 with a guide wire 78 that has been inserted during pre-procedure, with the help of x-ray or another imaging modality. This procedure often applies to non-palpable tumors, which are difficult to detect.

[0213] Preferably, the distance-measuring sensor 38 is an ultrasound transducer, and the guide wire 78 is visible by the ultrasound. Additionally, a guide-wire transducer 82 may be mounted on the tip 80, for sending signals that may be received by the distance-measuring sensor 38. Thus, the distance-measuring sensor 38 may estimate the distance to the tip 80, hence the distance to the second tissue type 16.

[0214] The guide wire transducer 82 may be, for example, a micro-electromechanical system (MEMS) ultrasound transducer, with a typical size of about 100  $\mu\text{m}$  in diameter. Furthermore, the distance-measuring sensor 38 may include three transducers, for calculating the exact position of the guide wire transducer 82, by triangulation. It will be appreciated that in the calculation of the distance between the guide wire transducer 82 and the distance-measuring sensor 38, it is assumed that the sound velocity in cancerous tissue and in healthy tissue is about the same.

[0215] Alternatively, the sensor 82 at the tip 80 of the guide wire 78 may be a magnetic positioning device, coupled with an RF transmitter, for transmitting its position, via RF signals, which may be received by an RF receiver on the integrated tool 10.

[0216] When the portion 15 has been removed, FIGS. 4b and 4c apply, as before.

[0217] Referring further to the drawings, FIGS. 5a-5c further illustrate the operational manner of the integrated tool 10 for clean-margin assessment, in accordance with the present invention.

[0218] As seen in FIG. 5a, as a first step, the integrated tool 10 is applied to an external surface 11, such as a skin, forming the surface 18, prior to cutting and prior to the removal of the portion 15 (FIG. 1). Alternatively, the surface 18 may be a lumen. The tissue-type sensor 33 will probably detect that the surface 18 is of the first tissue type 14 of healthy tissue, and the distance-measuring sensor 38 will detect the interface 22 with the second tissue type 16 at some depth.

[0219] As seen in FIG. 5b, when the incision begins, for the removal of the portion 15 (FIG. 1), the integrated tool 10 is applied to the tissue surface 18, now the tissue surface 18, to verify that the cutting proceeds as planned. At this stage, the tissue-type sensor 33 will detect that the near zone volume of the tissue surface 18 is of the first tissue type 14 of healthy tissue, and the distance-measuring sensor 38 will detect the interface 22 with the second tissue type 16 at some depth, approaching the desired depth 25 of the clean margin 24. Corrections and adjustments can be made in real time.

[0220] As seen in FIG. 5c, if cutting went too far, the tissue-type sensor 33 will detect that the near zone volume of the tissue surface 18 is of the second tissue type 16 of abnormal tissue, and the distance-measuring sensor 38 will not be able to provide useful information, as no clean margin exists.

[0221] Referring further to the drawings, **FIG. 6** schematically illustrates an overall computerized system **95**, for clean-margin assessment, in accordance with the present invention.

[0222] System **95** includes the integrated tool **10**, having the structure **45**, on which the tissue-type sensor **33** and the distance-measuring sensor **38** are mounted. Preferably, both sensors are located at the proximal end **30**, with respect to the tissue. Additionally, the integrated tool **10** may include the position-tracking device **50**, for providing its coordinates with respect to the frame of reference **54**, which defines a six-degree coordinate system, of x, y, z, and the rotational angles around them,  $\omega$ ,  $\theta$ , and  $\rho$ .

[0223] Data from the integrated tool **10** is carried to appropriate analyzers, preferably associated with a computer **90** for analysis. It will be appreciated that the computer **90** may be a personal computer, a laptop, a palmtop, a micro-computer, or another computer, as known.

[0224] For example, where the tissue-type sensor **33** is an electrical properties sensor, constructed essentially as the coaxial cable **44** (**FIGS. 2a-2c**), an electrical properties sensing module **94** includes, for example, an impedance analyzing external unit, such as Agilent 4396A, and a test fixture **89** connected via a coaxial cable to the impedance analyzing external unit.

[0225] Similarly, the distance-measuring sensor **38**, such as the ultrasound transducer **38** is associated with an ultrasound signal generator and analyzer **96**. The position-tracking device **50** may be associated with an analyzer **98**. The sensors may be battery operated or associated with power supply units.

[0226] The computer **90** which receives the data from the analyzers, preferably includes a user interface, for example, a keyboard **97**, or knobs, and may further include storage systems, such as a read and write drive **91**, a USB port **93**, and a display screen **92**.

[0227] It will be appreciated that where a different tissue-type sensor **33** is used, the unit **94** type will complement that sensor **33**. For example, where sensor **33** is an optical sensor, the unit **94** will be an optical analyzer. Similarly, where a different distance measuring sensor **38** is used, the unit **96** will complement that sensor **38**.

[0228] Information from the distance-measuring sensor **38** together with that of the position-tracking device **50** may be used for reconstructing a three-dimensional image of the tissue, by the computer **90**. Additionally, the three-dimensional image may be displayed on the screen **92**.

[0229] The system **95** may further include a guide wire **78**. At the proximal end **80**, the guide wire may include a sensor **82**, which may be an ultrasound transducer or a magnetic positioning device, coupled with a transmitter, for transmitting the positioning of the proximal tip, when inserted in the tissue, as taught hereinabove, in conjunction with **FIG. 4d**. Preferably, the sensor **82** is wireless, and operates via external interrogation, for example, from the distance-measuring sensor **38**, or on battery.

[0230] Referring further to the drawings, **FIGS. 7a-7d** schematically illustrate the integrated tool **10**, which further includes a retractable knife **106**, in accordance with a preferred embodiment of the present invention.

[0231] As seen in **FIG. 7a**, the knife is retracted, and the tool is used as described hereinabove.

[0232] As seen in **FIG. 7b**, the knife is deployed, and the tool is used for removing the portion **15**.

[0233] Thus the surgeon may use the integrated tool **10** both for measuring and characterizing the clean margin and for removing the portion **15**.

[0234] **FIG. 7c** illustrates the proximal view of the integrated tool **10**, in accordance with the present embodiment, while **FIG. 7d** provides a cross-sectional view.

[0235] Retraction and deployment are controlled by a knob **108**.

[0236] The knife **106** may be a cold knife, a diathermal knife, or another knife, as known.

[0237] Referring further to the drawings, **FIGS. 8a-8b** schematically illustrate the integrated tool **10**, operative with a frame **100** for fixing the soft tissue **12**, in accordance with a preferred embodiment of the present invention.

[0238] The frame **100** has a support plate **101** and a compression plate **102**. The compression plate **102** defines an opening **104**, through which the integrated tool **10** may be inserted.

[0239] In accordance with the present invention various sensors may be used for the tissue-type sensor **33**, for characterizing the near zone volume of the tissue surface **18** in contact with the integrated tool **10**. These are illustrated below, in conjunction with **FIGS. 9a-12b**.

[0240] Referring further to the drawings, **FIGS. 9a** and **9b** schematically illustrate the integrated tool **10**, wherein the tissue-type sensor **33** is formed as an RF or MW horn antenna **37**, mounted on the structure **45**, in accordance with still another embodiment of the present invention.

[0241] The RF or MW horn antenna **37** is associated with an RF/MW transmission line or wave guide **31**, while unit **94** (**FIG. 6**) is an RF/MW generation, collection and analysis unit.

[0242] The present embodiment relies on RF microwave characterization by the generation of propagating radiation in the RF microwave region of the electromagnetic spectrum, towards the tissue, and measuring its reflection. The radiation is usually transmitted and received by an antenna, for example the horn antenna **37**. The tissue characterization is done by analyzing the amplitude and phase difference between the original waves to the reflected wave.

[0243] Referring further to the drawings, **FIGS. 10a** and **10b** schematically illustrate the integrated tool **10**, wherein the tissue-type sensor **33** is formed as an optical sensor **47**, mounted on the structure **45**, in accordance with yet another embodiment of the present invention.

[0244] An optical signal is generated in an external unit, such as unit **94** (**FIG. 6**) and transmitted via an optical fiber **41** to the tissue. The reflection of the light is then received in a dedicated module inside the optical unit. The optical energy is usually transmitted to and from the tissue via a lens **43**.

[0245] The details of optical signal generation, receiving and analyzing depend on the specific optical method that is

chosen. For example, for reflection spectroscopy, tissue characterization relies on measuring the relative amplitude and phase of the reflected light versus the generated light. An example for the reflection spectroscopy method is described in commonly owned U.S. patent application 10/298196, whose disclosure is incorporated herein by reference. It will be appreciated that other methods may be used, as known.

[0246] Alternatively, auto fluorescence may be used, for measuring emitted radiation, from the tissue, at different a wavelength than that originally transmitted. The emitted radiation occurs in response to excitation by impinging radiation, and may be used for tissue characterization, for example, as used by Xillix Technologies Corp., #100-13775 Commerce Parkway, Richmond, British Columbia, Canada V6V 2V4, Telephone: 604-278-5000, and described in [http://www.xillix.com/index\\_home.cfm](http://www.xillix.com/index_home.cfm). It will be appreciated that other methods may be used, as known.

[0247] Referring further to the drawings, FIGS. 11a and 11b schematically illustrate the integrated tool for clean-margin assessment, wherein the tissue-type sensor 33 is formed as an MRI sensor 51, in accordance with yet another embodiment of the present invention.

[0248] The MRI sensor 51 has a permanent magnet 55, enclosed in an RF coil 53, for example, as taught in commonly owned US Patent Application 2005/0021019 to Hashimshony et al., entitled "Method and apparatus for examining substance, particularly tissue, to characterize its type," whose disclosure is incorporated herein by reference, and in U.S. Pat. No. 5,572,132, to Pulyer, et al., entitled, "MRI probe for external imaging," whose disclosure is incorporated herein by reference.

[0249] In accordance with the present invention various sensors may be used for the distance-measuring sensor 38, as illustrated below, in conjunction with FIG. 13.

[0250] It will be appreciated that many other tissue characterization sensors may be used, as known. These may include a sensor for tissue electromagnetic properties, a dielectric sensor, an impedance sensor, a sensor for optical fluorescence spectroscopy, a sensor for optical reflectance spectroscopy, an MRI sensor, a temperature sensor, and infrared thermography sensor, or another tissue-characterization sensor, as known.

[0251] Referring further to the drawings, FIGS. 12a and 12b schematically illustrate the integrated tool 10, wherein the distance-measuring sensor 38 is formed as a strain gauge 66, in accordance with still another embodiment of the present invention.

[0252] The present embodiment utilizes the approach of U.S. Pat. No. 6,546,787 to Schiller et al., whose disclosure is incorporated herein by reference, and which provides an apparatus and method for detecting a distance from a tissue edge to a malignant tissue, enclosed therein, i.e., a margin. The apparatus comprises a needle having a strain gage, mounted on one of the needles walls. Strain signals are collected as the needle is moved through the tissue. The needle is inserted at different points to allow data collection from different points within the tissue. The data is sent together with its spatial coordinates to a computerized system, which provides an image of the structure of the examined tissue.

[0253] As seen in FIGS. 12a and 12b, the structure 45 of the integrated tool 10 may include a lumen 65, wherein a needle 60 may be retracted and deployed, via a knob 62. The needle has a sharp edge 64, for penetrating the tissue. The strain gauge 66 senses the tissue resistance to the penetration, and provides data of resistance as a function of needle penetration depth. These measurements may be performed at various locations along the tissue surface 18.

[0254] Referring further to the drawings, FIGS. 13a and 13b schematically illustrate the integrated tool 10, wherein the distance-measuring sensor 38 is formed as a pressure sensor 68, at the needle's tip, in accordance with yet another embodiment of the present invention.

[0255] Again, the structure 45 of the integrated tool 10 may include the lumen 65, wherein the needle 60 may be retracted and deployed, via the knob 62. The pressure sensor 68 senses the tissue resistance to the penetration, and provides data of resistance as a function of needle penetration depth. These measurements may be performed at various locations along the tissue surface 18.

[0256] It will be appreciated that a non-invasive imager may be used for the distance-measuring sensor 38, for example, an MRI sensor.

[0257] Accordingly, the integrated tool 10 may be formed, for example, with the tissue-type sensor 33 being an optical sensor, and the distance-measuring sensor 38 being a non-invasive imager, such as an MRI sensor.

[0258] Referring further to the drawings, FIGS. 14a and 14b illustrate, in flowchart forms, surgical methods of tumor removal, using the integrated tool 10, in accordance with embodiments of the present invention,

[0259] As illustrated in FIG. 14a, a method 200 provides a computer-guided surgery, as follows:

[0260] in a box 202: providing the hand-held, integrated tool 10, which includes:

[0261] i. the tissue-type sensor 33, for determining a tissue type at a near zone volume of a tissue surface;

[0262] ii. the non-invasive imager 38, for example, an ultrasound sensor, or an MRI sensor; and

[0263] iii. the position tracking device 50.

[0264] in a box 204: fixing the tissue within a fixed frame, which defines a coordinate system, preferably of six-degrees, x, y, z, and the rotational angles around them,  $\omega$ ,  $\theta$ , and  $\rho$ .

[0265] in a box 206: imaging the tissue, within the fixed frame, from at least two, and preferably, a plurality of locations and orientations, by the hand-held, integrated tool 10.

[0266] in a box 208: reconstructing, by a computer, a three dimensional image of the tissue.

[0267] in a box 210: displaying the three dimensional image of the tissue.

[0268] in a box 212: defining a desired clean margin around a second tissue type.

[0269] in a box 214: displaying the desired clean margin.

- [0270] in a box 216: calculating a recommended incision path.
- [0271] in a box 218: displaying the recommended incision path.
- [0272] in a box 220: providing an incision instrument.
- [0273] in a box 222: cutting along the recommended incision path.
- [0274] in a box 224: determining the tissue type at the near zone volume of the tissue surface, by the hand-held, integrated tool 10.
- [0275] As illustrated in FIG. 14b, a method 230 further provides continuous correction to the method 200, as follows:
- [0276] in a box 232: continuously imaging the tissue, from different locations and orientations along the tissue surface, by the hand-held, integrated tool 10.
- [0277] in a box 234: continuously correcting the three dimensional image reconstruction of the tissue, as the tissue is being cut.
- [0278] in a box 236: continuously correcting the display of the three dimensional image of the tissue.
- [0279] in a box 238: continuously correcting the desired clean margin around the second tissue type.
- [0280] in a box 240: continuously displaying the continuously corrected desired clean margin.
- [0281] in a box 242: continuously correcting the recommended incision path.
- [0282] in a box 244: continuously displaying the continuously corrected recommended incision path.
- [0283] in a box 246 continuously determining the tissue type, at the near zone volume of the incision surface, by the hand-held, integrated tool 10.
- [0284] Preferably, the knife is integrated with the tool, as taught in conjunction with FIGS. 7a-7d.
- [0285] It is appreciated that certain features of the invention, which are, for clarity, described in the context of separate embodiments, may also be provided in combination in a single embodiment. Conversely, various features of the invention, which are, for brevity, described in the context of a single embodiment, may also be provided separately or in any suitable subcombination.
- [0286] Although the invention has been described in conjunction with specific embodiments thereof, it is evident that many alternatives, modifications and variations will be apparent to those skilled in the art. Accordingly, it is intended to embrace all such alternatives, modifications and variations that fall within the spirit and broad scope of the appended claims. All publications, patents and patent applications mentioned in this specification are herein incorporated in their entirety by reference into the specification, to the same extent as if each individual publication, patent or patent application was specifically and individually indicated to be incorporated herein by reference. In addition, citation or identification of any reference in this application shall not be construed as an admission that such reference is available as prior art to the present invention.

What is claimed:

1. An integrated tool, for clean-margin assessment, comprising:
  - a structure, which defines a proximal end with respect to a tissue and which is adapted for placement proximally to the tissue;
  - a tissue-type sensor, mounted on the structure, for determining a tissue type at a near zone volume of a tissue surface; and
  - a distance-measuring sensor, mounted on the structure, for determining a distance between the tissue surface and an interface with another tissue type,
 wherein the integrated tool is configured as a hand-held tool.
2. The integrated tool of claim 1, wherein the another tissue type is a cancerous tissue, and the integrated tool may be used to assess:
  - whether the tissue type at the near zone volume of the tissue surface is healthy; and
  - the distance between the tissue surface and an interface with the cancerous tissue.
3. The integrated tool of claim 1, adapted for operation in tandem with a surgical tool, for a real-time correction of a clean margin, where necessary.
4. The integrated tool of claim 1, and further including an incision instrument, integrated therewith, for a real-time correction of a clean margin, where necessary.
5. The integrated tool of claim 4, wherein the incision instrument may be selectively retracted and selectively deployed.
6. The integrated tool of claim 4, wherein the incision instrument is a diathermial incision instrument.
7. The integrated tool of claim 1, wherein the tissue-type sensor is selected from the group consisting of a sensor for tissue electromagnetic properties, a dielectric sensor, an impedance sensor, a sensor for optical fluorescence spectroscopy, a sensor for optical reflectance spectroscopy, an MRI sensor, an RF sensor, an MW sensor, a temperature sensor, and infrared thermography sensor.
8. The integrated tool of claim 1, wherein the tissue-type sensor is a dielectric-property sensor, formed substantially as a coaxial cable.
9. The integrated tool of claim 1, wherein the tissue surface is selected from the group consisting of a skin, a tissue lumen, and an incision surface.
10. The integrated tool of claim 1, wherein the distance-measuring sensor is an ultrasound transducer.
11. The integrated tool of claim 1, wherein the distance-measuring sensor is formed of two ultrasound transducers.
12. The integrated tool of claim 1, wherein the distance-measuring sensor is formed of an array of ultrasound transducers, which may be selectively steered.
13. The integrated tool of claim 1, wherein the distance-measuring sensor is selected from the group consisting of a strain gauge and a pressure sensor.
14. The integrated tool of claim 1, wherein the distance-measuring sensor is an MRI probe.
15. The integrated tool of claim 1, operative with a guide wire, wherein a proximal tip of the guide wire, with respect to the tissue, is placed within the another tissue type.

16. The integrated tool of claim 1, operative with a guide wire, wherein a proximal tip of the guide wire, with respect to the tissue, is placed in close proximity with the another tissue type.

17. The integrated tool of claim 1, operative with a guide wire, wherein the distance-measuring sensor is an ultrasound transducer, and the guide wire further includes a guide wire ultrasound transducer, at a proximal tip thereof, with respect to the tissue, for emitting ultrasound signals, indicative of the proximal-tip distance from the integrated tool.

18. The integrated tool of claim 1, operative with a guide wire, wherein the distance-measuring sensor is an ultrasound transducer, and the guide wire further includes a guide wire ultrasound transducer, at a proximal tip thereof, with respect to the tissue, for emitting ultrasound signals, indicative of the proximal-tip position with respect to the integrated tool, by triangulation.

19. The integrated tool of claim 1, and further including a position-tracking device.

20. The integrated tool of claim 19, wherein the position-tracking device is correlated with a coordinate system of a fixed frame, within which, the tissue is held fixed in place.

21. A system for clean-margin assessment, comprising:

a hand-held, integrated tool, for clean-margin assessment, which comprises:

a structure, which defines a proximal end with respect to a tissue and which is adapted for placement proximally to the tissue;

a tissue-type sensor, mounted on the structure, for determining a tissue type at a near zone volume of a tissue surface; and

a distance-measuring sensor, mounted on the structure, for determining a distance between the tissue surface and an interface with another tissue type; and

a computerized system, which comprises:

a tissue-type-sensor analyzer, associated with the tissue-type sensor;

a distance-measuring-sensor analyzer, associated with the distance-measuring sensor; and

an output device, which provides output of measurements by the tissue-type sensor and the distance-measuring sensor.

22. The system of claim 21, wherein the another tissue type is a cancerous tissue, and the integrated tool may be used to assess:

whether the tissue type at the near zone volume of the tissue surface is healthy; and

the depth to an interface with the cancerous tissue.

23. The system of claim 21, and further including a fixed frame for holding the tissue therein.

24. The system of claim 21, and further including a position-tracking device and a position-tracking-device analyzer.

25. The system of claim 21, and further including a computer.

26. A system for clean-margin assessment, comprising:

a fixed frame for holding a tissue therein, the frame defining a coordinate system;

a hand-held, integrated tool, for clean-margin assessment, which comprises:

a structure, which defines a proximal end with respect to the tissue and which is adapted for placement proximally to the tissue;

a tissue-type sensor, mounted on the structure, for determining a tissue type at a near zone volume of a tissue surface;

an imager, operative as a distance-measuring sensor, mounted on the structure, for determining a distance between the tissue surface and an interface with another tissue type; and

a position-tracking device, mounted on the structure and correlated with the coordinate system; and

a computerized system, which comprises:

a tissue-type-sensor-analyzer, associated with the tissue-type sensor;

a distance-measuring-sensor analyzer, associated with the distance-measuring sensor;

a position-tracking-device analyzer, associated with the position-tracking device;

a computer, for receiving data from the tissue-type-sensor analyzer, the distance-measuring-sensor analyzer, and the position-tracking-device analyzer, and performing analysis thereof; and

an output device, associated with the computer.

27. A method of clean-margin assessment, comprising:

providing a hand-held, integrated tool, for clean-margin assessment, which comprises:

a structure, which defines a proximal end with respect to a tissue and which is adapted for placement proximally to the tissue;

a tissue-type sensor, mounted on the structure, for determining a tissue type at a near zone volume of a tissue surface; and

a distance-measuring sensor, mounted on the structure, for determining a distance between the tissue surface and an interface with another tissue type;

determining the tissue type at the near zone volume of the tissue surface; and

determining the distance between the tissue surface and the interface with the another tissue type.

28. A method of clean-margin assessment, comprising:

providing a hand-held, integrated tool, for clean-margin assessment, which comprises:

a structure, which defines a proximal end with respect to a tissue and which is adapted for placement proximally to the tissue;

a tissue-type sensor, mounted on the structure, for determining a tissue type at a near zone volume of a tissue surface;

a non-invasive imager, mounted on the structure; and

a position-tracking device, mounted on the structure;

fixing the tissue within a fixed frame, which defines a coordinate system;

imaging the tissue, from at least two locations and orientations, by the hand-held, integrated tool;

reconstructing a three dimensional image of the tissue;

displaying the three dimensional image of the tissue;

defining a desired clean margin around another tissue type;

displaying the desired clean margin;

calculating a recommended incision path;

displaying the recommended incision path;

providing an incision instrument;

cutting along the recommended incision path; and

determining the tissue type at the near zone volume of the tissue surface, by the hand-held, integrated tool.

**29.** The method of claim 28, and further including:

continuously imaging the tissue, from different locations and orientations along the tissue surface, by the hand-held, integrated tool;

continuously correcting the recommended incision path; and

continuously displaying the continuously corrected recommended incision path.

**30.** The method of claim 29, and further including continuously determining the tissue type, at the near zone volume of the incision surface, by the hand-held, integrated tool.

\* \* \* \* \*

专利名称(译)	清洁保证金评估工具		
公开(公告)号	<a href="#">US20060253107A1</a>	公开(公告)日	2006-11-09
申请号	US10/558831	申请日	2005-03-23
[标]申请(专利权)人(译)	沙丘医疗设备有限公司		
申请(专利权)人(译)	DUNE医疗器械有限公司.		
当前申请(专利权)人(译)	DUNE医疗器械有限公司.		
[标]发明人	HASHIMSHONY DAN COHEN GIL GELTNER IDDO		
发明人	HASHIMSHONY, DAN COHEN, GIL GELTNER, IDDO		
IPC分类号	A61B17/00 A61B18/18 A61B8/00 A61B5/103 A61B5/117 A61B5/00 A61B5/05 A61B5/053 A61B5/055 A61B5/06 A61B8/08 A61B8/12 A61B18/08 A61B19/00		
CPC分类号	A61B5/0071 A61B2019/5295 A61B5/0084 A61B5/0086 A61B5/0091 A61B5/01 A61B5/015 A61B5/0507 A61B5/053 A61B5/055 A61B5/06 A61B5/415 A61B5/4312 A61B8/0858 A61B8/12 A61B8/4472 A61B18/082 A61B19/5244 A61B2017/00026 A61B2019/461 A61B2019/507 A61B2019/5251 A61B2019/5255 A61B2019/5276 A61B5/0075 A61B8/4245 A61B34/20 A61B2034/107 A61B2034/2051 A61B2034/2055 A61B2090/061 A61B2090/367 A61B2090/378		
优先权	60/555901 2004-03-23 US		
其他公开文献	US7720532		
外部链接	<a href="#">Espacenet</a> <a href="#">USPTO</a>		

摘要(译)

提供了一种集成工具，其具有组织型传感器，用于确定组织表面的近区域体积处的组织类型，以及距离测量传感器，用于确定到与另一组织类型的界面的距离，用于 (i) 确认在被移除的恶性肿瘤周围存在清洁的健康组织边缘，以及 (ii) 确定清洁边缘的深度。集成工具还可包括位置跟踪装置和切口器械。软组织可以保持在固定框架内，同时移除肿瘤。另外，提供了一种用于恶性肿瘤去除的方法，包括：将软组织固定在框架内，利用手持的集成工具从围绕软组织的多个位置和取向进行成像，重建三维图像。软组织和肿瘤，在重建图像上定义所需的清洁边缘，计算推荐的切口路径，在重建图像上显示推荐路径，并在确定其类型时切割组织，在切口的近区域体积表面。该方法还可以包括利用切割连续成像，连续地校正重建图像和推荐切口路径，并且在切口表面的近区域体积处连续地确定组织类型。

