



US 20040171914A1

(19) **United States**

(12) **Patent Application Publication**
Avni

(10) **Pub. No.: US 2004/0171914 A1**

(43) **Pub. Date: Sep. 2, 2004**

(54) **IN VIVO SENSING DEVICE WITH A
CIRCUIT BOARD HAVING RIGID SECTIONS
AND FLEXIBLE SECTIONS**

Related U.S. Application Data

(60) Provisional application No. 60/298,387, filed on Jun. 18, 2001.

(76) Inventor: **Dov Avni, Haifa (IL)**

Publication Classification

Correspondence Address:
**EITAN, PEARL, LATZER & COHEN ZEDEK
LLP
10 ROCKEFELLER PLAZA, SUITE 1001
NEW YORK, NY 10020 (US)**

(51) **Int. Cl.⁷ A61B 1/04**

(52) **U.S. Cl. 600/160; 600/109**

(57) **ABSTRACT**

A device including at least one image sensor and a circuit board having a plurality of rigid sections and a plurality of flexible sections. The image sensor is disposed on a rigid section of the circuit board. The circuit board may be folded into a housing configured for in vivo sensing.

(21) Appl. No.: **10/481,126**

(22) Filed: **Dec. 18, 2003**

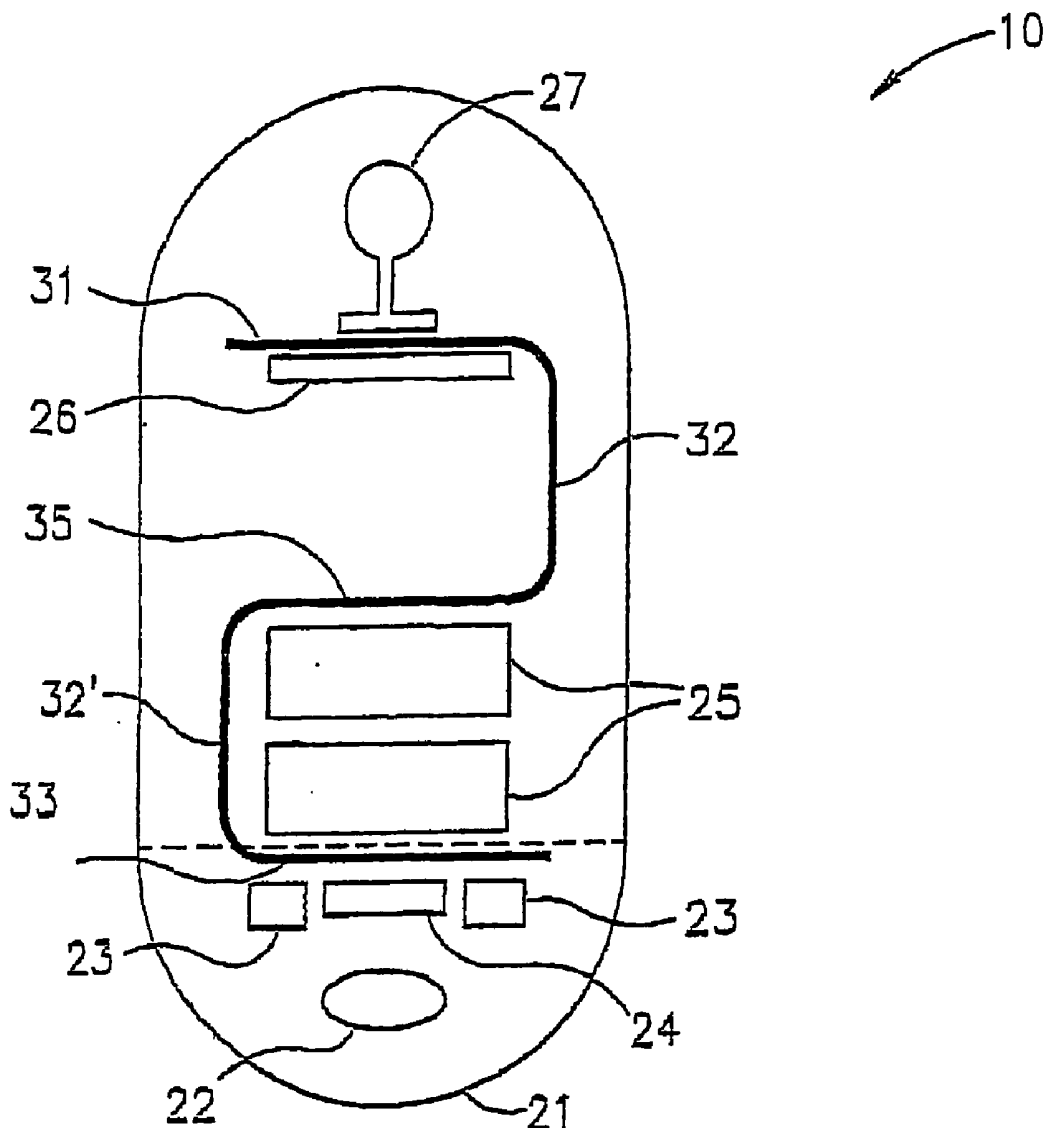

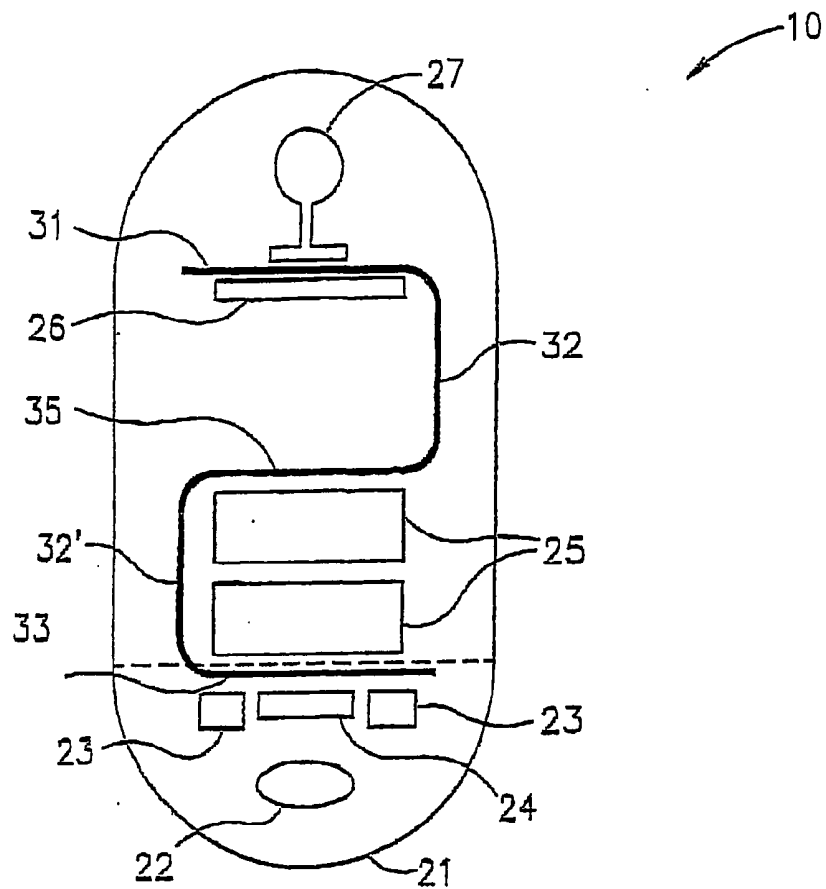

FIG. 1

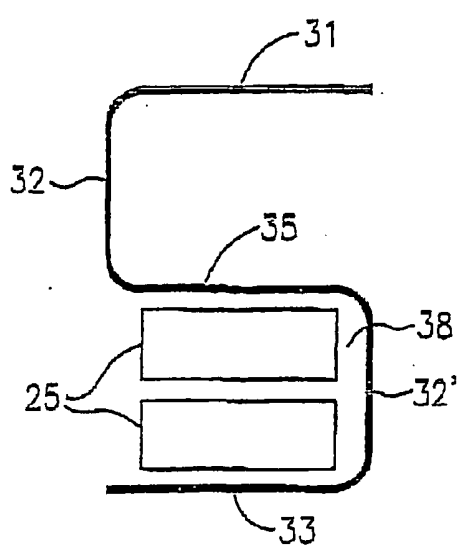

FIG. 2A

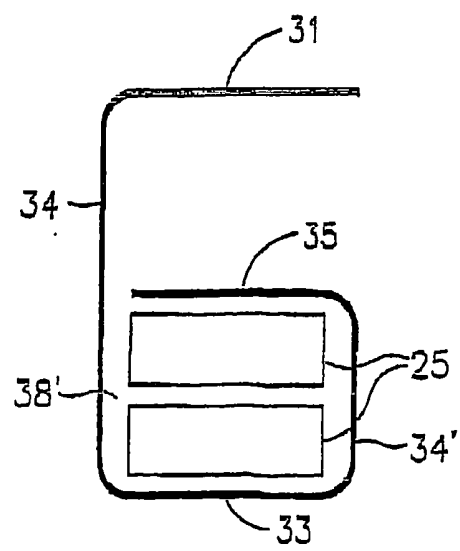

FIG. 2B

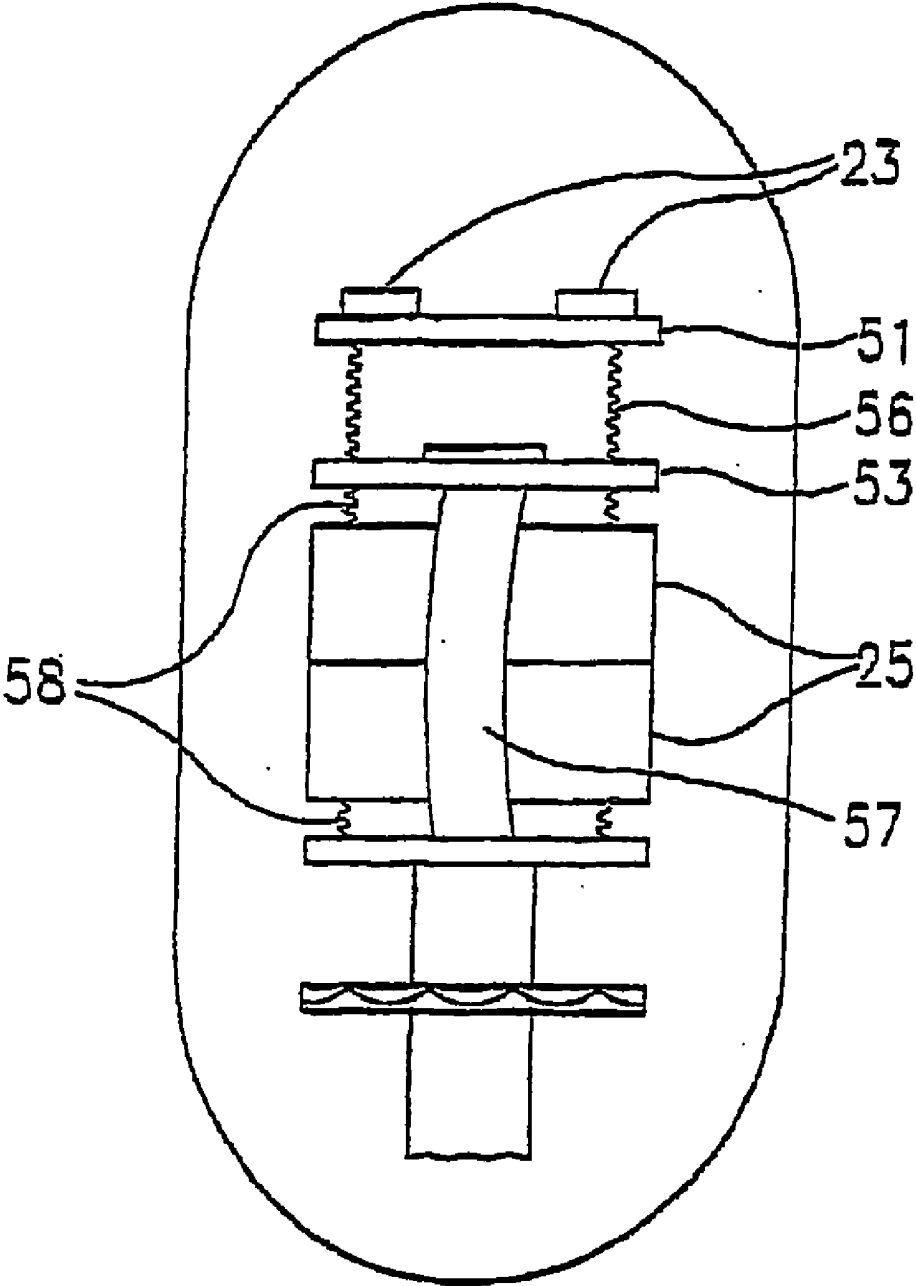

FIG. 3

IN VIVO SENSING DEVICE WITH A CIRCUIT BOARD HAVING RIGID SECTIONS AND FLEXIBLE SECTIONS

FIELD OF THE INVENTION

[0001] The present invention relates to an in vivo imaging device and system such as for imaging the digestive tract.

BACKGROUND OF THE INVENTION

[0002] In vivo imaging may include the use of an in vivo imager from which image data may be transmitted to an external receiving system. For example, an ingestible capsule comprising an image sensor and a transmitter for transmitting image data may be used for imaging the gastrointestinal (GI) tract. In some ingestible capsules the electronic components within the capsule may be arranged on several boards, each board containing different components of the capsule, for example, the image sensor, typically a silicon chip, may be positioned on one board whereas the transmitter may be positioned on a separate printed circuit board (PCB). In some cases the boards are aligned along an axis of the capsule and are electrically connected by a plurality of wires. Assembly of capsules having several boards connected by wires may be complex and may hinder, for example, large scale production.

SUMMARY OF THE INVENTION

[0003] Thus, the present invention provides, according to some embodiments an in vivo sensing device comprising a circuit board having a plurality of rigid sections and a plurality of flexible sections. According to one embodiment the rigid sections and flexible sections alternate. Optionally, the in vivo sensing device may include at least an image sensor. According to another embodiment the device may also include a transmitter for transmitting signals from a sensors such as an imaging camera, to a receiving system. In one embodiment various components in the device, such as the image sensor and transmitter, are disposed on different rigid circuit board sections. Preferably, the circuit board is folded and arranged in a stacked vertical fashion. In a further embodiment, the various rigid portions may be connected by vertical connectors such as springs.

BRIEF DESCRIPTION OF THE DRAWINGS

[0004] The present invention will be understood and appreciated more fully from the following detailed description taken in conjunction with the drawings in which:

[0005] **FIG. 1** schematically illustrates an in vivo imaging device according to one embodiment of the invention;

[0006] **FIGS. 2A** and **2B** schematically illustrate possible folding of the circuit board according to two embodiments of the invention; and

[0007] **FIG. 3** schematically illustrates an in vivo imaging device according to a third embodiment of the invention.

DETAILED DESCRIPTION OF THE INVENTION

[0008] In the following description, various aspects of the present invention will be described. For purposes of explanation, specific configurations and details are set forth in order to provide a thorough understanding of the present

invention. However, it will also be apparent to one skilled in the art that the present invention may be practiced without the specific details presented herein. Furthermore, well-known features may be omitted or simplified in order not to obscure the present invention.

[0009] The system and method of the present invention may be used with an imaging system such as that described in WO 01/65995. A further example of an imaging system with which the system and method of the present invention may be used is described in U.S. Pat. No. 5,604,531 to Iddan et al. Both these publications are assigned to the common assignee of the present application and are hereby incorporated by reference. Alternatively, the system of the present invention may be utilized in any suitable imaging device providing images of a body lumen or cavity. For example, a circuit board according to an embodiment of the invention may be utilized in probes used for in vivo imaging, such as endoscopes.

[0010] Reference is now made to **FIG. 1**, which schematically illustrates an in vivo imaging device according to an embodiment of the invention. The device **10** typically comprises an optical window **21** and an imaging system for obtaining images from inside a body lumen, such as the GI tract. The imaging system includes an illumination source **23**, such as a white LED, a CMOS imaging camera **24**, which detects the images and an optical system **22** which focuses the images onto the CMOS image sensor **24**. The illumination source **23** illuminates the inner portions of the body lumen through optical window **21**. Device **10** further includes a transmitter **26** and an antenna **27** for transmitting image signals from the CMOS image sensor **24**, and a power source **25**, such as a silver oxide battery, that provides power to the electrical elements of the device **10**. A suitable CMOS image sensor **24** is, for example, a "camera on a chip" type CMOS imager specified by Given Imaging Ltd. of Yokneam, Israel and designed by Photobit Corporation of California, USA. The single chip camera can provide either black and white or color signals. A suitable transmitter may comprise a modulator which receives the image signal (either digital or analog) from the CMOS imaging camera, a radio frequency (RF) amplifier, an impedance matcher and an antenna. A processor, e.g., for processing the image data may be included in the device. The processor or processing circuitry may be integrated in the sensor or in the transmitter.

[0011] The device **10** is capsule shaped and can operate as an autonomous endoscope for imaging the GI tract. However, other devices, such as devices designed to be incorporated in an endoscope, catheter, stent, needle, etc., may also be used, according to embodiments of the invention. Furthermore, the device **10** need not include all the elements described above. For example, the device **10** need not include an internal light source or an internal power source; illumination and/or power may be provided from an external source, as known in the art.

[0012] According to one embodiment of the invention, the various components of the device **10** are disposed on a circuit board including rigid and flexible portions; preferably the components are arranged in a stacked vertical fashion. For example, one rigid portion **31** of the circuit board may hold a transmitter and an antenna; preferably the antenna is at one end of the capsule to avoid screening of the signal by metal or other components in the capsule. Another rigid

portion **33** of the circuit board includes an LED **23** lighting system and an imager **24** on one side; the other side of this rigid portion **33** includes a battery **25** contact. The battery contact is preferably a spring, described below. Another rigid portion **35** of the circuit board includes another battery contact. Each rigid portion of the circuit board is connected to another rigid portion of the circuit board by a flexible connector portion (e.g. **32** and **32'**) of the circuit board. Preferably, each rigid portion of the circuit board comprises two rigid sections; sandwiched between the rigid sections is a flexible connector portion of the circuit board for connecting the rigid boards. In alternate embodiments, other arrangements of components may be placed on a circuit board having rigid portions connected by flexible portions.

[0013] In alternate embodiments, a circuit board having rigid portions and flexible portions may be used to arrange and hold components in other in vivo sensing devices, such as a swallowable capsule measuring acidity (having a pH sensor), temperature or pressure, or in a swallowable imaging capsule having components other than those described above.

[0014] Preferably, each flexible connector portion is equal to or less than $\frac{1}{1000}$ inch (4 mils) in thickness. Preferably, electrical connection is made from the outside portion of a rigid portion board (on which components are mounted) to the inside of the rigid portion and to the flexible portion contained within, by a small (equal to or less than 4 mils in diameter) hole leading from the outside portion to the flexible portion—a micro-via. Preferably the micro-via is created using a laser. Companies providing such flexible connector and micro-via technology are Eltech, of Petach-Tikva, Israel, and Ilfa, of Germany. In alternate embodiments, other types of rigid sections and flexible sections may be used to create a circuit board.

[0015] The circuit board may be folded, for example, as shown in FIGS. **2A** and **2B**. When folded, the battery contacts contact a set of one or more batteries, which are sandwiched between two rigid circuit board portions. The circuit board may be folded in various manners. For example, FIG. **2A** schematically shows a circuit board, according to an embodiment of the invention, arranged as an “S” with rigid portions **31**, **35** and **33** and alternating flexible portions **32** and **32'**. A set of batteries **25** may be sandwiched between one lobe **38** of the S. Another configuration, according to an embodiment of the invention is schematically shown in FIG. **2B**. The circuit board, according to an embodiment of the invention may be in the shape of a “6” with rigid portions **31**, **35** and **33** and alternating flexible portions **34** and **34'**. A set of batteries **25** may be positioned in the closed configuration **38'** of the “6”. Other configurations are possible. In alternate embodiments, batteries may be connected in different manners, or need not be used.

[0016] Preferably, a very thin flexible section is needed due to the radius of the diameter of the turns, given the size of the capsule, and also because the flexible section may be disposed between components, such as between the set of batteries and the side of the capsule. Preferably, the radius of the turn should be more than 6 or 10 times the thickness. In alternate embodiments, the rigid boards and flexible connectors may be of other dimensions.

[0017] In one embodiment, the rigid portions of the circuit board may include any sort of known material; preferably

FR4 flexiglass is used. The flexible portions may include any sort of known material; preferably, Kapton™ by DuPont is used.

[0018] Reference is made to FIG. **3**, which schematically illustrates another view of an embodiment of the invention. According to one embodiment, a vertical physical and electrical connection may be made between rigid portions of the circuit board. For example, the rigid portion **51** holding the LED **23** (which is preferably in the shape of a ring) may be connected physically and electrically to another rigid portion apart from being connected by flexible portion **57**. In one embodiment, mini springs **56** are used to connect a power supply from one circuit rigid portion **53** to the rigid portion **51** holding the LED **23**. Such springs **56** have two functions; to mechanically connect the two rigid portions (e.g., **51** and **53**) and also to conduct current between the two rigid portions. Preferably, the springs are glued to the two rigid portions, and current flows between two rigid portions.

[0019] In addition, a vertical connection is made between the set of batteries **25** and two rigid portions by springs **58**. Each contact spring **58** is preferably a conical spring, which, as it shrinks, allows each circle or coil of the spring to enter a larger encircling coil. Thus, when fully shrunken, the final thickness of the spring is thickness of a single circle of conductor wire.

[0020] There is also provided a method for the manufacture of a in vivo sensor, in accordance with an embodiment of the invention. The method includes the steps of disposing at least a sensor on a rigid section of a circuit board having a plurality of rigid sections and a plurality of flexible sections and folding the circuit board into a housing configured for in vivo sensing.

[0021] It will be appreciated by persons skilled in the art that the present invention is not limited to what has been particularly shown and described hereinabove. Rather the scope of the present invention is defined only by the claims which follow:

1. An in vivo sensing device comprising a circuit board having a plurality of rigid sections and a plurality of flexible sections.
2. The device according to claim 1 and also comprising a sensor.
3. The device according to claim 2 wherein the sensor is an image sensor.
4. The device according to claim 2 wherein the sensor is selected from the group consisting of a pH sensor, a temperature sensor and a pressure sensor.
5. The device according to claim 1 further comprising an image sensor.
6. The device according to claim 2 and also comprising a transmitter.
7. The device according to claim 1 further comprising at least one component selected from the group consisting of an illumination source, a power source, a sensor, a processor, a transmitter or a combination thereof.
8. The device according to claim 7 wherein at least one component is disposed on at least one rigid section of the circuit board.
9. The device according to claim 7 wherein a plurality of components are disposed on a plurality of rigid sections of the circuit board.

10. The device according to claim 6 wherein the sensor is disposed on a rigid section of the circuit board and the transmitter is disposed on another rigid section of the circuit board.

11. The device according to claim 1 wherein the rigid sections alternate with the flexible sections.

12. The device according to claim 1 wherein the circuit board is folded such that the rigid sections of the circuit board are stacked vertically.

13. The device according to claim 13 wherein the rigid sections are connected by vertical connectors.

14. The device according to claim 13 wherein the vertical connectors are electrical conductors.

15. The device according to claim 13 wherein the vertical connectors are springs.

16. The device according to claim 15 wherein the springs are conical springs.

17. The device according to claim 1 wherein the circuit board includes flexiglass.

18. The device according to claim 9 wherein the components are electrically connected through micro-via in the rigid sections.

19. A method for the manufacture of an in vivo sensor, the method comprising the steps of:

disposing at least a sensor on a rigid section of a circuit board having a plurality of rigid sections and a plurality of flexible sections; and

folding the circuit board into a housing configured for in vivo sensing.

20. The method according to claim 19 wherein the step of folding the circuit board includes folding the circuit board such that the rigid sections of the circuit board are stacked vertically.

21. A device comprising at least one in vivo sensor and a circuit board having a plurality of rigid sections and a plurality of flexible sections, wherein the sensor is disposed on at least one rigid section of the circuit board.

22. A device comprising at least one image sensor and a circuit board having a plurality of rigid sections and a plurality of flexible sections, wherein the image sensor is disposed on at least one rigid section of the circuit board.

23. The device according to claim 22 further comprising a transmitter for transmitting image signals, said transmitter disposed on another rigid section of the circuit board.

* * * * *

专利名称(译)	具有电路板的体内传感装置具有刚性部分和柔性部分		
公开(公告)号	US20040171914A1	公开(公告)日	2004-09-02
申请号	US10/481126	申请日	2002-06-18
[标]申请(专利权)人(译)	AVNI DOV		
申请(专利权)人(译)	AVNI DOV		
当前申请(专利权)人(译)	AVNI DOV		
[标]发明人	AVNI DOV		
发明人	AVNI, DOV		
IPC分类号	A61B5/01 A61B1/00 A61B1/04 A61B1/05 A61B5/00 A61B5/07 H05K1/00 H05K1/18		
CPC分类号	A61B1/04 A61B1/041 H05K3/3436 H05K1/189 H05K2201/10151 A61B5/0031 Y02P70/613		
优先权	60/298387 2001-06-18 US		
其他公开文献	US7998065		
外部链接	Espacenet USPTO		

摘要(译)

一种可吞咽的体内传感胶囊(10)，包括：电路板，包括多个刚性部分(31,33,35; 51,53)，所述刚性部分(33,35)中的至少两个通过柔性连接部分(32,32'和39;)和一个或多个电池(25)位于两个刚性部分之间，可吞咽的体内传感胶囊还包括设置在至少一个刚性部分(33,51)上的照明源(23)电路板。

