



(19) **United States**

(12) **Patent Application Publication**
Hochman et al.

(10) **Pub. No.: US 2003/0083590 A1**

(43) **Pub. Date: May 1, 2003**

(54) **SYSTEM AND METHOD FOR
TRANSDUCING, SENSING, OR AFFECTING
VAGINAL OR BODY CONDITIONS, AND/OR
STIMULATING PERINEAL MUSCULATURE
AND NERVES USING 2-WAY WIRELESS
COMMUNICATIONS**

Publication Classification

(51) **Int. Cl.⁷** **A61B 5/00**
(52) **U.S. Cl.** **600/549; 600/551; 600/591**

(75) **Inventors: Joel S. Hochman, Houston, TX (US);
George Sarkis, Orinda, CA (US)**

Correspondence Address:
ROBERT W. BECKER & ASSOCIATES
Suite B
11896 N. Highway 14
Tijeras, NM 87059 (US)

(73) **Assignee: Athena Feminine Technologies, Inc.,
Orinda, CA 94563 (US)**

(21) **Appl. No.: 10/007,393**

(22) **Filed: Oct. 26, 2001**

(57) **ABSTRACT**
A system and method are provided for transducing vaginal conditions, affecting vaginal or body conditions, and/or stimulating perineal musculature and nerves. A separate, portable, non-implanted intravaginally containable combination probe and transceiver is provided that can sense vaginal conditions, can deliver signals or medication, and/or can stimulate perineal musculature and nerves. This probe unit is provided with 2-way wireless communication for transmitting information that is transduced and for receiving control and programming signals. In addition, a separate combination controller and transceiver is provided for wirelessly sending signals to the probe unit and for receiving signals therefrom. A real time wireless signal feedback loop is thus provided between the controller and the probe and/or external devices, networks and databases.

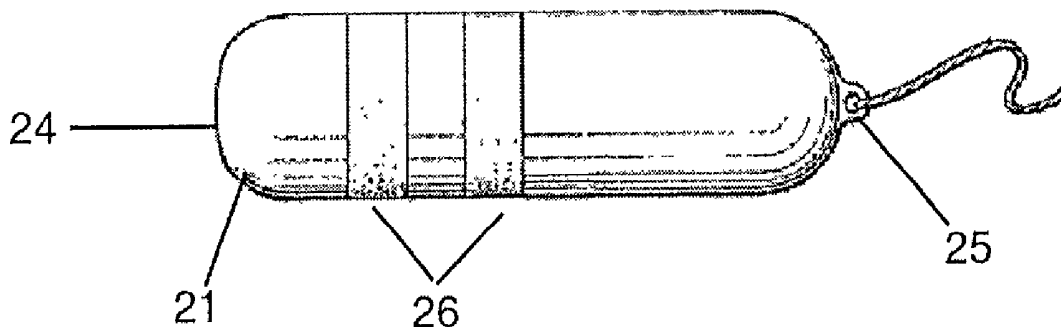

FIG 1

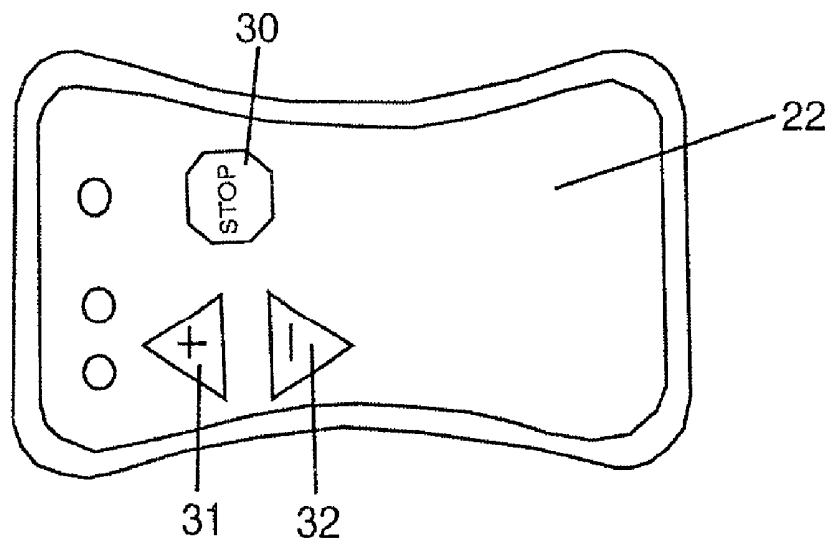
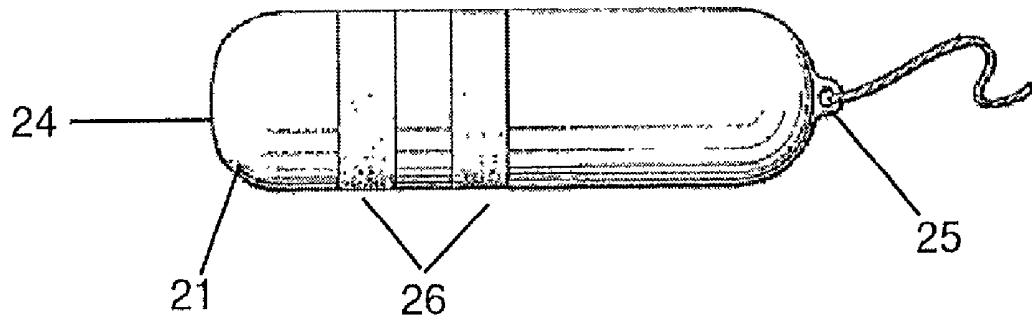
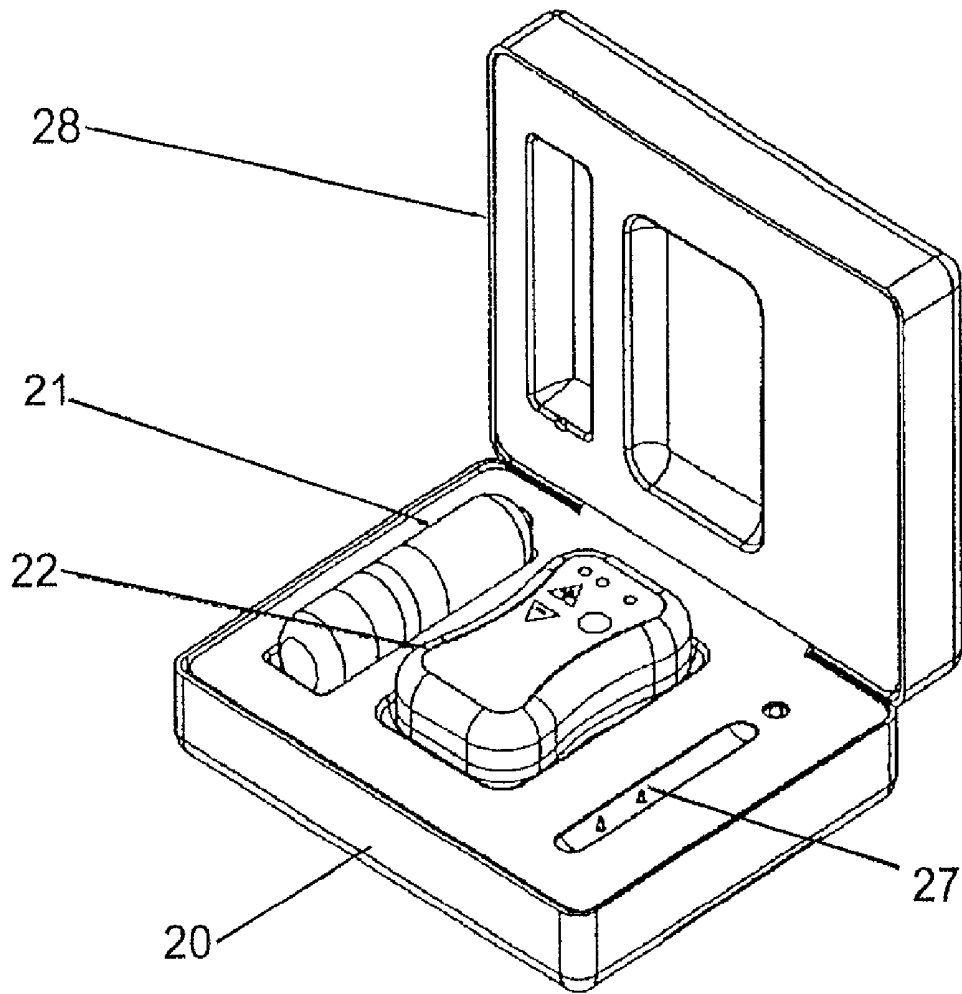

FIG 2

FIG 3



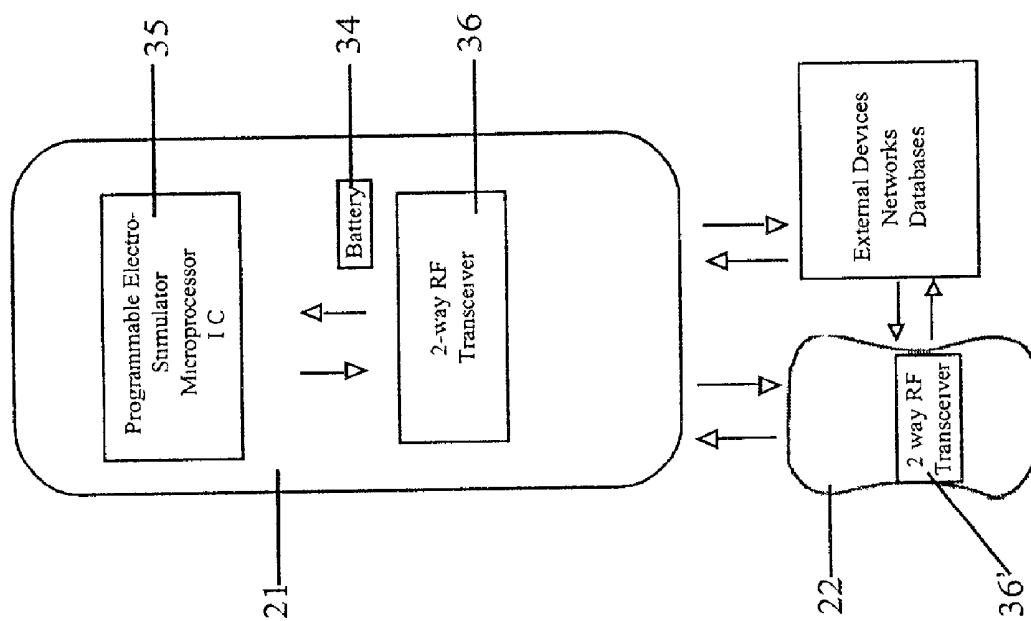

FIG. 4

FIG 5

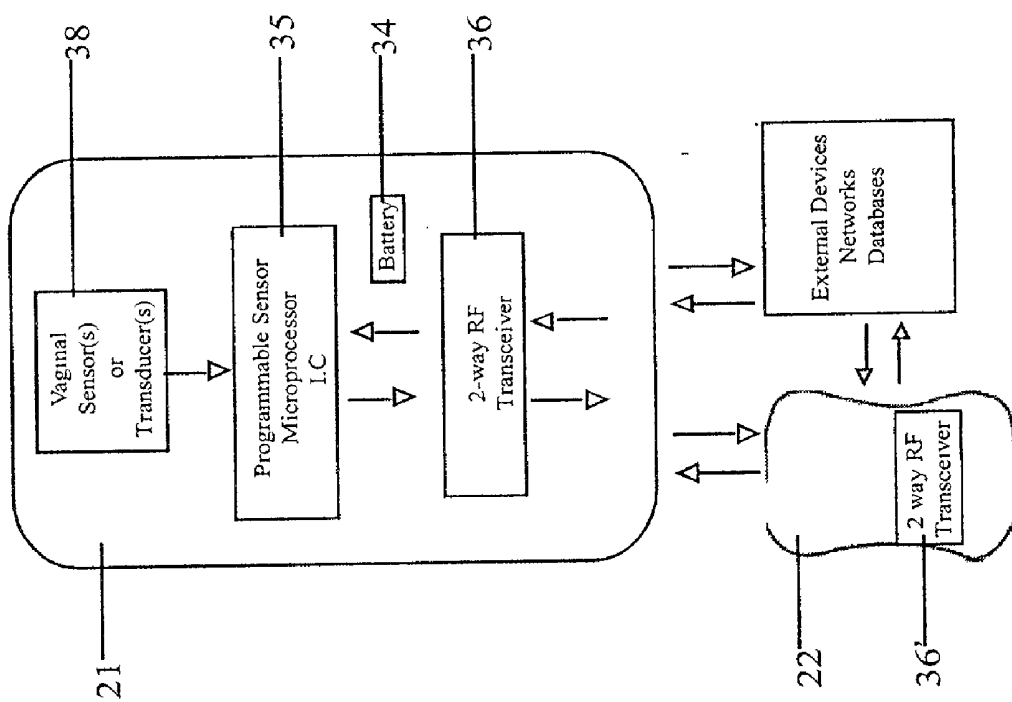
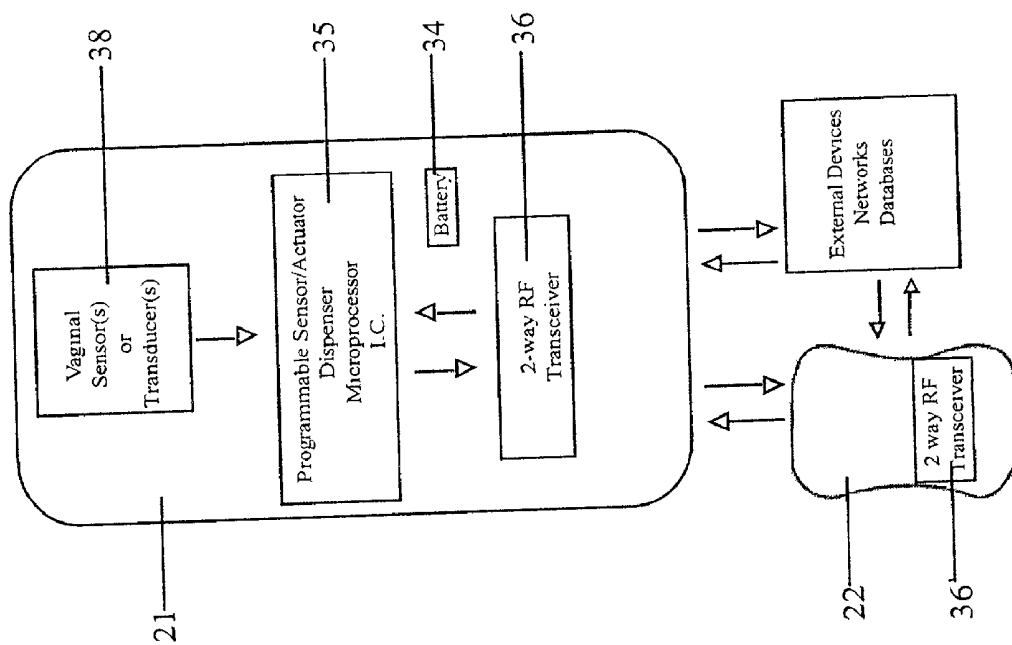

FIG 6



**SYSTEM AND METHOD FOR TRANSDUCING,
SENSING, OR AFFECTING VAGINAL OR BODY
CONDITIONS, AND/OR STIMULATING PERINEAL
MUSCULATURE AND NERVES USING 2-WAY
WIRELESS COMMUNICATIONS**

BACKGROUND OF THE INVENTION

[0001] The present invention relates to a system for transducing vaginal conditions, affecting vaginal or body conditions and/or stimulating perineal musculature and nerves. The present invention also relates to a method for accomplishing these functions.

[0002] U.S. Pat. No. 4,515,167, Hochman, discloses a self-contained stimulation device that was programmable, prior to use, using control buttons on the surface of the device itself. Signals could also be emitted from the device to an external unit for processing. The drawbacks of this known device include the inability to alter its operation during use. In addition, this known device is not very ergonomic due in particular to the surface control buttons that are necessarily present on the device for its programming and operation.

[0003] Other vaginally insertable probes are also known, such as the fertility probes of U.S. design Pat. No. 393,311 and U.S. Pat. No. 5,916,173, both to Kirsner. U.S. Pat. No. 4,753,247, Kirsner, discloses a probe that is connected by wires to an external housing containing batteries and electronic circuitry.

[0004] Prior known devices fail to provide a system that can provide stimulation, deliver medication, and/or obtain physiological data intravaginally, via a wireless 2-way communication and in real time.

[0005] It is therefore an object of the present invention to provide an ergonomic system and method that will allow, in a wireless manner and in real time, the transducing of vaginal conditions, the affecting of vaginal or body conditions, and the stimulation of perineal musculature and nerves in the human or other mammalian vagina, and in particular allows for real time remote control and/or programming of the intravaginally contained probe/transceiver unit.

BRIEF DESCRIPTION OF THE DRAWINGS

[0006] This object, and other objects and advantages of the present invention, will appear more clearly from the following specification in conjunction with the accompanying schematic drawings, in which:

[0007] **FIGS. 1 and 2** show the probe/transceiver and the controller/transceiver units respectively of the system of the present invention;

[0008] **FIG. 3** shows the probe and controller units in a case; and

[0009] **FIGS. 4-6** diagrammatically show the micro circuitry for various exemplary embodiments of the inventive probe and controller units.

SUMMARY OF THE INVENTION

[0010] The system of the present invention comprises: a separate, portable, non-implanted, intravaginally containable (i.e. in situ yet removable) combination probe and

transceiver that is provided with means for sensing vaginal conditions, delivering signals or medication, and/or stimulating perineal musculature and nerves, wherein such probe unit is provided with 2-way wireless real time communication means for transmitting information that is transduced and for receiving control and programming signals; and a separate combination controller and transceiver that is provided with wireless means for sending signals to the probe unit and for receiving signals therefrom, wherein a wireless signal feedback loop is provided between the controller and probe units and external devices, networks and databases.

[0011] The combination probe and transceiver is, in particular, a pre-programmed unit. The programming of this unit can, however, be altered. As indicated, 2-way communication is provided between the probe unit and the controller unit, which can be a hand-held unit, but could alternatively or in addition be a PC or other similar computer unit.

[0012] The probe of the inventive system contains no wires or similar external means or surface controls, and is therefore comfortable to use.

[0013] When the probe unit of the inventive system is used as a stimulation unit, women are provided a safe, easy and convenient way to strengthen and tone their pelvic muscles without professional intervention or special training.

[0014] In addition, or alternatively, the probe unit of the inventive system can be provided with solid state transducers or other sensor means that would be able to identify, for example, sexually transmitted pathogens, cancerous changes in the cervix and vaginal environment, metabolic abnormalities, physiological markers of the fertility cycle, and other physiological information. It may also be possible in this way to identify diseases by DNA sequences or by disease-specific molecular odors. The inventive system thus affords the ability of being able to provide the earliest possible diagnosis and treatment of pathological conditions, since it is now possible with the inventive system to obtain intracorporeal physiological information without the need for parenteral or invasive sampling. In other words, physiological information can be wirelessly tracked and monitored, allowing observation and supervision of metabolic and fertility activities, among others. This can even be done from a remote site, since the diagnostic data can be wirelessly transmitted to local hubs, local area networks, personal computers, and the internet. Thus, the inventive system can provide sophisticated diagnostic data to the user, to her physician, and to internet-hosted diagnostic services. Of particular significance is that this transfer of information is accomplished in real time.

[0015] Further specific features of the present invention will be explained in detail subsequently.

**DESCRIPTION OF PREFERRED
EMBODIMENTS**

[0016] Referring now to the drawings in detail, the inventive system, which is designated generally by the reference numeral **20 (FIG. 3)**, essentially comprises two separate straightforward, self-contained units, namely a combination probe and transceiver **21** and a combination controller and transceiver **22**. The required components of these units are integrated and, where appropriate, sealed into these two units. The bodies of the units **21,22** are made of a plastic,

such as those approved for medical use by the Food and Drug Administration. An example of such a plastic is medical grade level polycarbonate.

[0017] Although, as indicated previously, the inventive system 20 has numerous applications, including sensing or transducing vaginal conditions, affecting vaginal or body conditions, and/or stimulating perineal musculature and nerves, the system will now be explained in conjunction with use as a stimulation system.

[0018] When the system 20 is used as a stimulation system, the combination probe and transceiver unit is characterized as a stimulator unit. In one specific embodiment of the present invention, such a stimulator unit is less than 1 inch in diameter and less than 4 inches in length. The end 24 of the unit 21 is rounded to facilitate vaginal insertion. The opposite end of the unit can be provided with, for example, an eyelet 25 to which a cord or similar device can be attached to facilitate removal of the reusable unit. The body of the unit is provided with at least one electrode ring 26 (two such rings are shown in the embodiment illustrated in FIG. 1), with these electrode rings being flush with the outer surface of the unit. The electrode rings 26 are designed to deliver electrical pulses to the muscles and/or nerves of the pelvic floor, and are preferably metallic rings, although they could also be made of non-metallic conducting material such as doped silicon. The stimulator unit 21 is furthermore provided with a microprocessor, a radio transmitter and a receiver mounted on a circuit board, an antenna and a sealed battery, as will be discussed in detail subsequently.

[0019] The operation of the combination probe and transceiver in its function as a stimulator unit will now be described by way of example. To begin a session, a woman would remove the hand-held combination controller and transceiver (the control unit) 22 and the stimulator unit 21 from the holder or case 28 (see FIG. 3), which also includes a tester 27 for the probe or stimulator unit. The stimulator unit 21 is then inserted into the vagina. The stimulator unit 21 can be turned on automatically at a low level when it is removed from the case 28; this can be accomplished, for example, either by a signal from the control unit 22 or can be triggered by a non-illustrated magnet located in the case 28. Although automatic powering up is preferred, the stimulator unit 21 can also be turned on manually using the on/off button 30 of the control unit 22.

[0020] The stimulator unit 21 can operate entirely automatically by being preprogrammed. For example, the unit can start at a low level of about 2 volts, can hold this voltage for approximately 30 seconds or any other desired period of time, and can then automatically ramp up to, for example, 5 volts. The stimulator unit 21 could also be operated manually by the control unit 22, or the control unit could be used to override the programmed stimulator unit 21. For example, the hand-held control unit 22 can be used to increase the stimulation strength in small steps until a user feels the muscles contract. This would be accomplished by using the Increase button 31. Should the woman feel any discomfort, she can decrease the strength of stimulation by pushing the Decrease button 32, or can turn the system off by pushing the OFF button 30. The system can be programmed to run for a specified period of time, for example in fifteen minute cycles, after which it will automatically shut off. The stimulator unit 21 can then be removed.

[0021] During a session, which, as indicated above, could run for approximately 15 minutes, the stimulator unit 21 is programmed to follow a pattern of several stimulation cycles, each of which is followed by a rest period with a repeat of the set of stimulation cycles and rest periods. The stimulation patterns are the well known Kegel patterns. The stimulator unit 21 can be programmed so that it will automatically ramp up to the setting of a previous use; in other words, the stimulator unit and/or the control unit 22 is provided with a memory.

[0022] To accomplish the various functions of the system 20, namely of the control unit 22 and the stimulator or combination probe and transceiver unit 21, these units are provided with a number of components (see FIG. 4). In particular, the stimulator unit 21 and control unit 22 respectively include a battery 34, a microprocessor 35, and a radio transmitter and receiver, or preferably a transceiver 36, 36' which includes an antenna. The radio transmitters and receivers, or transceivers, of the control unit 22 and of the probe unit 21 are miniature radio transceivers of the same low power class as of the known remote keyless locking devices used in automobiles. The programmable microprocessors of the units are designed to receive signals from the other unit and to deliver signals thereto, all in a wireless signal feedback loop, which may be closed or interactive. By way of example, electrical stimulation pulses can be delivered to the perineal musculature via the aforementioned electrode rings 26.

[0023] The control unit 22 and the probe unit 21 can also be provided with wireless means to transmit signals to or receive signals from external devices, networks or databases, including a PC which may be located in a doctor's office, thereby facilitating data transmission and analysis.

[0024] It should also be noted that although the control unit 22 is preferably a hand-held unit, it could also be an appropriately programmed and equipped PC or the like.

[0025] As indicated above, the combination probe and transceiver unit 21 can be provided with means, such as one or more sensors with appropriate circuitry, for transducing vaginal conditions, delivering signals or medication, and/or stimulating perineal musculature and nerves. For this purpose, the combination probe and transceiver 21 is provided with the 2-way wireless communication means 36 for transmitting transduced information to the control unit 22, external devices, networks or databases and for receiving control and programming signals therefrom. Similarly, the control unit or combination controller and transceiver 22 is provided with wireless means, such as a transceiver 36', for sending wireless signals to the unit 21 and for receiving wireless signals therefrom. Thus, a wireless signal feedback loop is provided between the control unit 22 and the probe unit 21. Further inventive embodiments are illustrated in FIGS. 5 and 6.

[0026] In particular, the combination controller and transceiver 22 can include means for altering the operational settings of the probe unit 21. The combination probe and transceiver 21 can be provided with sensing or transducing means in the form of a muscle contraction sensor, and the unit 21 can also be provided with medication delivery means. In addition, the control unit 22 can be provided with means for altering stimulation signal levels and/or medication delivery signals.

[0027] The combination probe and transceiver unit **21** can also be provided with stimulating means (as in the embodiment of **FIG. 4**), which can be programmed to provide increasing stimulation and/or medication over a given period of time. The stimulating means can include means for automatic adjustment of stimulation levels in response to sensed muscle contractions and/or changes in the vaginal environment. Such stimulating means can be remotely adjustable, for example from the control unit **22** or from another source.

[0028] The combination probe and transceiver unit **21** can also be provided with means for sampling cervical fluid, and/or with means for sensing temperature, pH, secretion viscosity, vaginal pathogens and atypical cervical cells. The various sensors and transducers can be provided at any suitable location on the probe as long as the ergonomic character of the probe is maintained. Where appropriate, the sensors/transducers could even be in the form of the electrode rings **26**.

[0029] As indicated previously, the combination probe and transceiver unit **21** is a sealed unit.

[0030] The present invention is, of course, in no way restricted to the specific disclosure of the specification and drawings, but also encompasses any modifications within the scope of the appended claims.

We claim:

1. A system for at least one of transducing vaginal conditions, affecting vaginal or body conditions, and stimulating perineal musculature and nerves, comprising:

a separate, portable, non-implanted, intravaginally containable combination probe and transceiver that is provided with means for at least one of sensing vaginal conditions, delivering signals or medication, and stimulating perineal musculature and nerves;

wherein said combination probe and transceiver is provided with 2-way wireless communication means for transmitting information that is transduced and for receiving control and programming signals; and

a separate combination controller and transceiver that is provided with wireless means for sending signals to said probe and for receiving signals therefrom;

wherein a wireless signal feedback loop is provided between said controller and said probe and which may be an interactive or closed signal feedback wireless loop.

2. A system according to claim 1, wherein said means of said combination wireless controller and transceiver for sending signals includes means for wirelessly altering operation settings of said probe.

3. A system according to claim 2, wherein said probe is provided with means for transducing in the form of a muscle contraction sensor.

4. A system according to claim 2, wherein said probe is provided with means for transducing in the form of means for sampling cervical fluid or other changes in the vaginal environment.

5. A system according to claim 2, wherein said probe is provided with means for transducing in the form of means

for sensing at least one of temperature, pH, secretion viscosity, vaginal pathogens and atypical cervical cells.

6. A system according to claim 2, wherein said probe is a sealed unit which is inserted "in-situ" into the vaginal vault or removed therefrom.

7. A system according to claim 3, wherein said means of said controller and transceiver for sending signals includes means for wirelessly altering at least one of stimulation signal levels and medication.

8. A system according to claim 3, wherein said probe is provided with stimulating means that includes means for automatic adjustment of stimulation levels in response to at least one of sensed muscle contractions and changes in the vaginal environment.

9. A system according to claim 2, wherein said probe is provided with stimulating means, and wherein said stimulating means is programmed to provide at least one of increasing stimulation and medication over a given period of time.

10. A system according to claim 9, wherein said stimulating means is remotely adjustable via a wireless signal.

11. A system according to claim 6, wherein said probe is provided with at least one of at least one conductive band and a sensor transducer.

12. A system according to claim 1, wherein said controller and said probe are provided with a wireless means to transmit signals to and/or receive signals from external devices, networks, or databases.

13. A system according to claim 6, where said controller is a hand-held unit.

14. A method of accomplishing at least one of transducing vaginal conditions, affecting vaginal or body conditions, and stimulating perineal musculature and nerves, said method including the steps of:

intravaginally inserting a portable, combination probe and transceiver;

with said combination probe and transceiver accomplishing at least one of transducing vaginal conditions, delivering signals or medication, and stimulating perineal musculature and nerves;

providing said combination probe and transceiver with 2-way wireless communication means for transmitting transduced information and for receiving control and programming signals;

providing a separate combination controller and transceiver that is provided with wireless means for sending signals to said combination probe and transceiver and for receiving signals therefrom; and

providing a wireless signal feedback loop between said combination probe and transceiver on the one hand and said combination controller and transceiver on the other hand.

15. A method according to claim 14, which includes the step of transmitting and/or receiving signals, in a wireless manner, to and from external devices, networks or databases.

* * * * *

专利名称(译)	使用双向无线通信转换，感测或影响阴道或身体状况和/或刺激会阴肌肉组织和神经的系统和方法		
公开(公告)号	US20030083590A1	公开(公告)日	2003-05-01
申请号	US10/007393	申请日	2001-10-26
[标]申请(专利权)人(译)	雅典娜费米尼技术有限公司		
申请(专利权)人(译)	ATHENA FEMININE TECHNOLOGIES, INC.		
当前申请(专利权)人(译)	ATHENA FEMININE TECHNOLOGIES, INC.		
[标]发明人	HOCHMAN JOEL S SARKIS GEORGE		
发明人	HOCHMAN, JOEL S. SARKIS, GEORGE		
IPC分类号	A61B A61B5/00 A61B5/103 A61N1/36		
CPC分类号	A61B5/0002 A61B5/01 A61B5/04 A61B5/14539 A61B5/227 A61B5/4337 A61N1/36007 A61B2010/0019 A61B2010/0022 A61B2010/0074 A61B2562/242 A61H2201/5097 A61N1/0524 A61B10/0045		
其他公开文献	US7577476		
外部链接	Espacenet USPTO		

摘要(译)

提供了一种系统和方法，用于转导阴道病症，影响阴道或身体状况，和/或刺激会阴肌肉组织和神经。提供了单独的，便携式，非植入的阴道内可容纳的组合探针和收发器，其可以感测阴道状况，可以递送信号或药物，和/或可以刺激会阴肌肉组织和神经。该探测单元具有双向无线通信，用于发送被转换的信息以及用于接收控制和编程信号的信息。另外，提供单独的组合控制器和收发器，用于无线地向探测器单元发送信号并从中接收信号。因此，在控制器和探针和/或外部设备，网络和数据库之间提供实时无线信号反馈回路。

