



US 20090326416A1

(19) **United States**

(12) **Patent Application Publication**
McNulty et al.

(10) **Pub. No.: US 2009/0326416 A1**

(43) **Pub. Date: Dec. 31, 2009**

(54) **DETECTING INFECTION IN REDUCED PRESSURE WOUND TREATMENT**

(76) Inventors: **Amy McNulty**, San Antonio, TX (US); **Deepak Kilpadi**, San Antonio, TX (US); **George M. Hutchinson**, San Antonio, TX (US); **Nancy Price**, San Antonio, TX (US)

Correspondence Address:
KINETIC CONCEPTS, INC.
C/O SONNENSCHN NATH & ROSENTHAL LLP
P.O. BOX 061080, WACKER DRIVE STATION,
WILLIS TOWER
CHICAGO, IL 60606 (US)

(21) Appl. No.: **12/477,704**

(22) Filed: **Jun. 3, 2009**

Related U.S. Application Data

(60) Provisional application No. 61/058,819, filed on Jun. 4, 2008, provisional application No. 61/118,161, filed on Nov. 26, 2008.

Publication Classification

(51) **Int. Cl.**
A61B 5/00 (2006.01)
A61M 1/00 (2006.01)
G01N 33/53 (2006.01)
C12Q 1/66 (2006.01)
C12Q 1/68 (2006.01)
(52) **U.S. Cl.** **600/573; 604/319; 435/7.32; 435/8; 435/7.1; 435/6; 435/7.9**

(57) **ABSTRACT**

Provided is a method of detecting infection in a wound caused by an infecting organism at a wound site. Also provided is a system for detecting an infection in a wound at a wound site. Additionally, a porous pad comprising luciferase is provided.

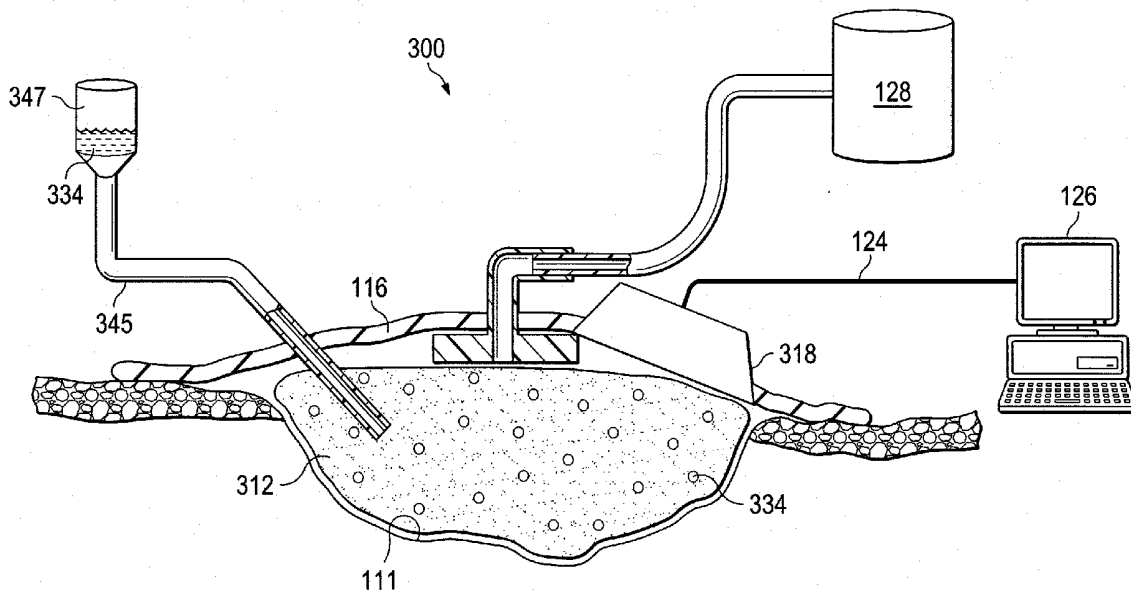

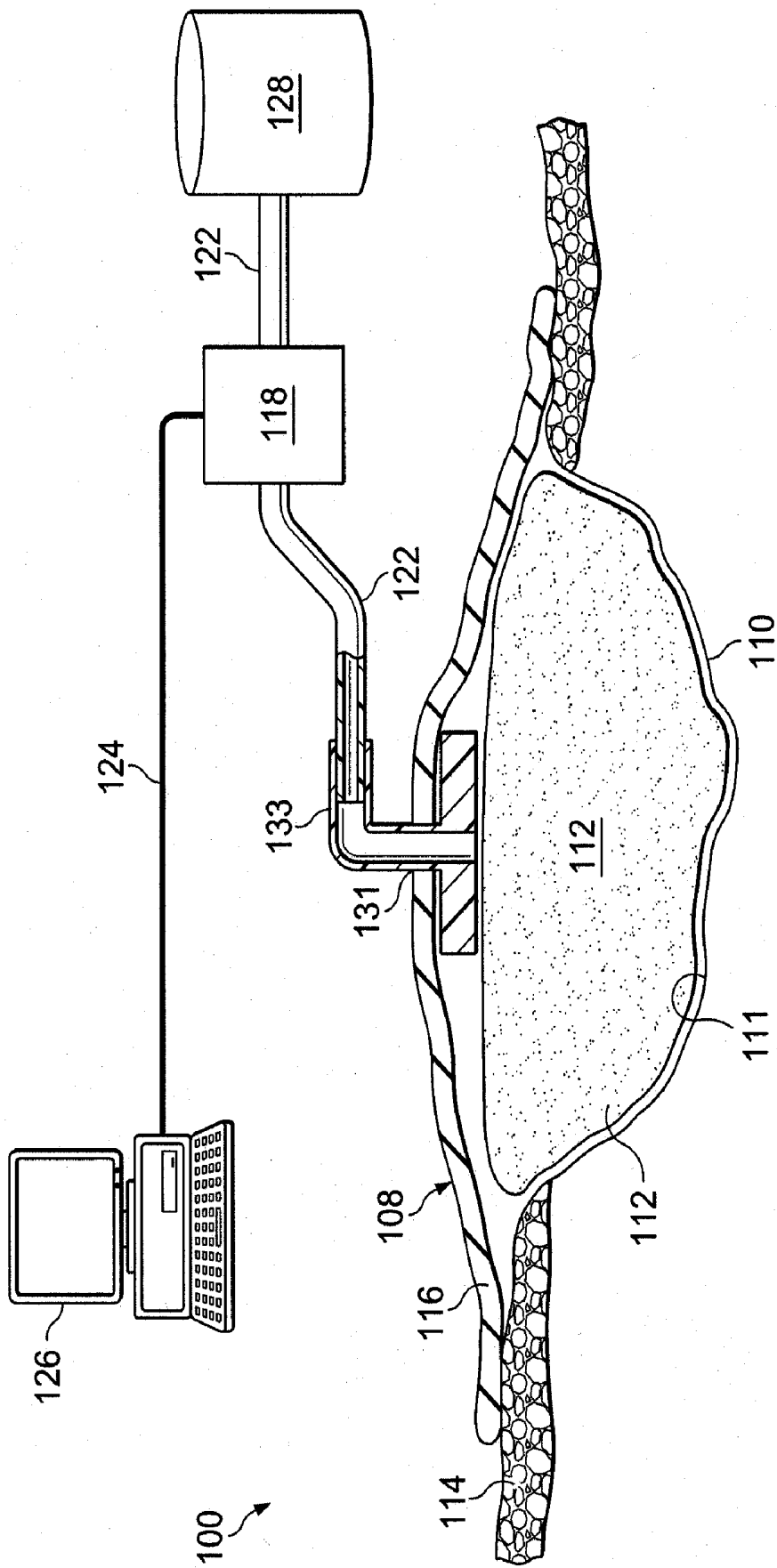

FIG. 1

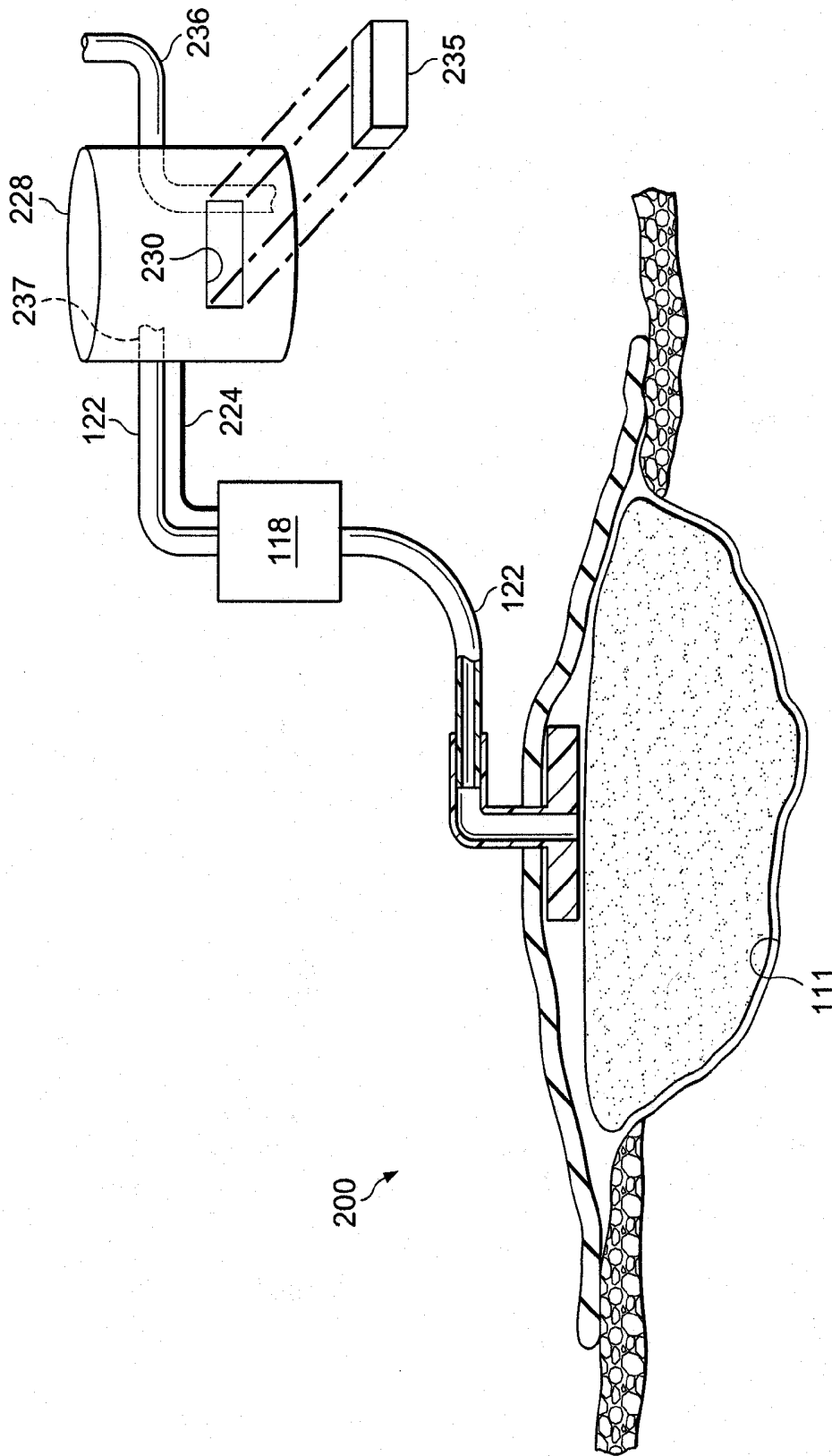

FIG. 2

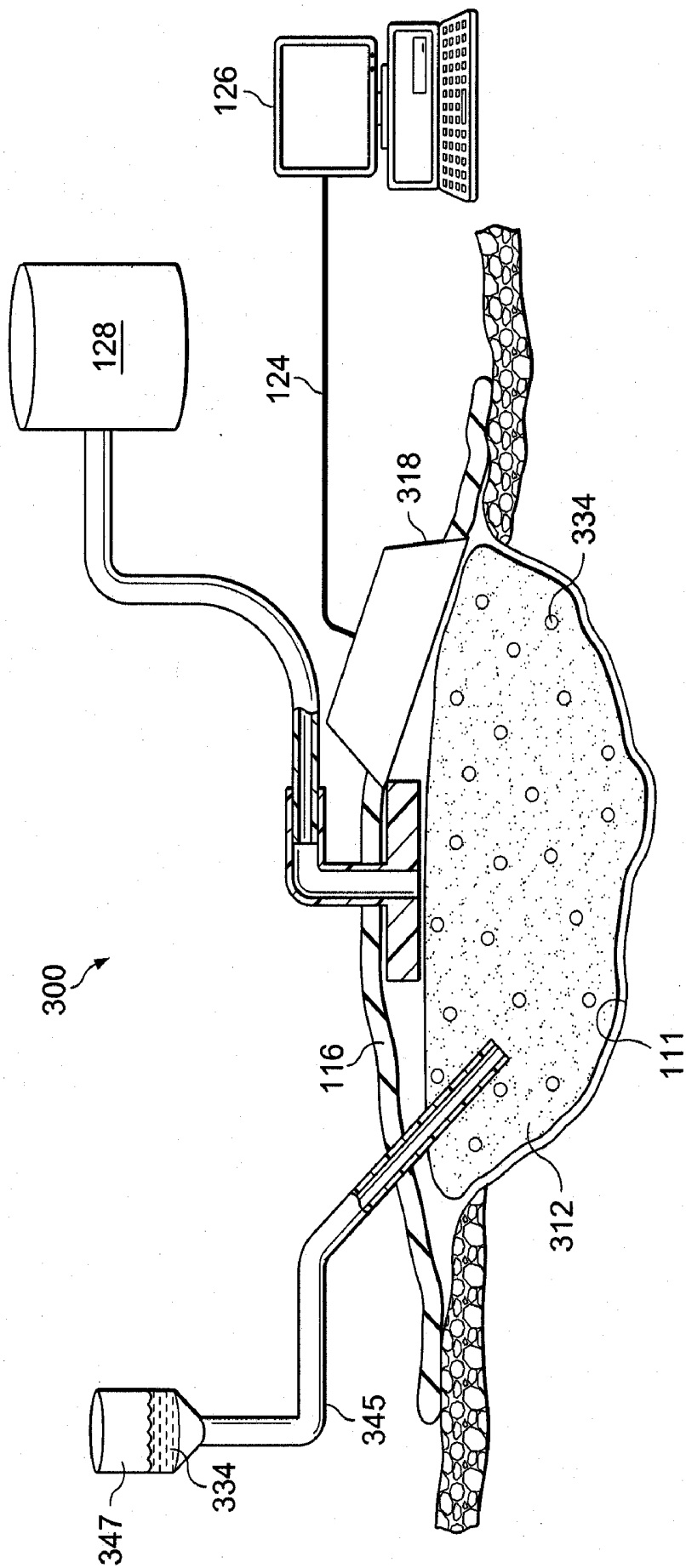

FIG. 3

DETECTING INFECTION IN REDUCED PRESSURE WOUND TREATMENT

CROSS-REFERENCE TO RELATED APPLICATIONS

[0001] This application claims the benefit of U.S. Provisional Application No. 61/058,819, filed Jun. 4, 2008, and U.S. Provisional Application No. 61/118,161, filed Nov. 26, 2008, both of which are incorporated by reference.

BACKGROUND

[0002] 1. Field of the Invention

[0003] The present invention relates generally to tissue treatment systems and in particular to methods and compositions for detecting infection in a wound.

[0004] 2. Description of Related Art

[0005] Clinical studies and practice have shown that a system for providing a reduced pressure in proximity to a tissue site augments and accelerates the growth of new tissue at the tissue site. The applications of this phenomenon are numerous, but application of reduced pressure has been particularly successful in treating wounds. This treatment (frequently referred to in the medical community as “negative pressure wound therapy,” “reduced pressure therapy,” or “vacuum therapy”) provides a number of benefits, including faster healing and increased formulation of granulation tissue. Typically, reduced pressure is applied to tissue through a porous pad or other manifold device. The porous pad contains cells or pores that are capable of distributing reduced pressure to the tissue and channeling fluids that are drawn from the tissue. The porous pad often is incorporated into a dressing having other components that facilitate treatment.

[0006] One difficulty associated with the use of such systems is detecting the presence or type of infection present in the wound without disturbing the airtight dressing covering the wound. Numerous methods have been developed relating to the detection of microorganisms. Various forms of those methods include the use of spectrometers, chromatographs, and other electronic sensors for detecting the presence of microorganisms. Exemplary U.S. patents include Lewis, et al. U.S. Pat. No. 6,017,440 issued Jan. 25, 2000; Chutjian, et al. U.S. Pat. No. 6,188,067 issued Feb. 13, 2001; Hunter, et al. U.S. Pat. No. 5,811,255 issued Sep. 22, 1998; Overton, et al. U.S. Pat. No. 5,611,846 issued Mar. 18, 1997; and Yu U.S. Pat. No. 5,583,281 issued Dec. 10, 1996.

[0007] While such systems have been highly successful in the promotion of wound closure, healing many wounds previously thought untreatable, some difficulty remains. Because the very nature of such systems require an atmospherically sealed wound site, it is difficult to detect the presence or concentration of contaminant microorganisms such as bacteria that may be present in the wound site, without removing the wound dressing. It has heretofore been necessary to disturb the wound site, and thereby interrupt the therapy, in order to test for the presence or concentration of bacterial infection. Furthermore, any disturbance to the wound site may increase the possibility of infection to the wound site. Additionally, removal of the wound dressing may cause pain or discomfort to the patient.

[0008] Some progress has been made to circumvent these problems with the invention described in United States Patent Application Publication US2002/0143286, incorporated herein by reference. That application describes the use of

sensing devices that optically sense the presence of a bacterial agent or other form of infection in the wound fluid. Other methods to more specifically identify and quantify the infectious agent are desirable.

[0009] Accordingly, a primary object of the present invention is to provide a vacuum assisted wound closure device that utilizes a means for detecting the presence of an infection present at a wound site during utilization of an airtight dressing without disturbing the dressing at the wound site.

[0010] A further object of the present invention is to provide a means for identifying the nature or specific type of infection present at a wound site during the utilization of an airtight dressing without disturbing the dressing at the wound site.

[0011] It is yet a further object of the present invention to provide a means for detecting the concentration of an infecting agent present at a wound site during utilization of an airtight dressing without disturbing the dressing at the wound site.

SUMMARY

[0012] The problems presented by existing means for detection of infection in reduced pressure treatment are solved by the methods and apparatuses of the illustrative embodiments described herein. In one embodiment, a method of detecting infection in a wound caused by an infecting organism at a wound site is provided that includes applying a reduced pressure to the wound site, withdrawing fluid from the wound site in response to the reduced pressure, collecting the fluid withdrawn from the wound site, and assaying the fluid collected from the wound site for a product of the infection or a component of the infecting organism, whereby the presence of the product or the component indicates the presence of an infection in the wound.

[0013] In an additional embodiment, a system for detecting an infection in a wound at a wound site is provided that includes a source of reduced pressure, a porous pad adapted to deliver the reduced pressure to the wound site, a drape adapted to provide a substantially airtight cover over the pad and the wound site, a conduit fluidly connecting the porous pad to the source of reduced pressure whereby fluid is withdrawn from the wound site in response to the reduced pressure, and a device for analyzing the fluid withdrawn from the wound site to identify a product of the infection or a component of an infecting organism, whereby the presence of the product of the component indicates the presence of an infection in the wound.

[0014] In a further embodiment, a porous pad adapted for distributing reduced pressure to a wound site is provided that includes luciferase.

[0015] Other objects, features, and advantages of the illustrative embodiments will become apparent with reference to the drawings and detailed description that follow.

BRIEF DESCRIPTION OF THE DRAWINGS

[0016] FIG. 1 is a diagram, shown in partial cross-section, of an illustrative embodiment of a reduced-pressure treatment system for detecting infection.

[0017] FIG. 2 is a diagram, shown in partial cross-section, of an illustrative embodiment of a reduced-pressure treatment system for detecting infection in which the reduced-pressure source includes a compartment for receiving a chip.

[0018] FIG. 3 is a diagram, shown in partial cross-section, of an illustrative embodiment of a reduced-pressure treatment system having a pad that contains a substance.

DETAILED DESCRIPTION

[0019] In the following detailed description of the illustrative embodiments, reference is made to the accompanying drawings that form a part hereof. These embodiments are described in sufficient detail to enable those skilled in the art to practice the invention, and it is understood that other embodiments may be utilized and that logical structural, mechanical, electrical, and chemical changes may be made without departing from the spirit or scope of the invention. To avoid detail not necessary to enable those skilled in the art to practice the embodiments described herein, the description may omit certain information known to those skilled in the art. The following detailed description is, therefore, not to be taken in a limiting sense, and the scope of the illustrative embodiments are defined only by the appended claims.

[0020] Referring to FIG. 1, an illustrative embodiment of a reduced-pressure treatment system 100 provides reduced-pressure treatment to a tissue site 110, which may include a wound 111, and detects infections in the tissue site 110. The reduced-pressure treatment system 100 includes a reduced-pressure source 128, fluidly connected to a conduit 122, that delivers reduced pressure to the tissue site 110 via a dressing 108. The dressing 108 includes a pad 112 that is disposed in the wound 111. A drape 116 is adhered to the patient's epidermis 114 and provides a fluid seal around the wound 111, allowing the maintenance of reduced pressure on the wound 111. Reduced pressure causes fluid, such as exudate, from the wound 111 to be drawn to a device 118 for analyzing the withdrawn fluid or extract thereof for a product of an infection or a component of an infecting organism or group of organisms.

[0021] The wound 111 may be an injury or defect located on or within any tissue site 110, including but not limited to, bone tissue, adipose tissue, muscle tissue, subcutaneous tissue, neural tissue, dermal tissue, vascular tissue, connective tissue, cartilage, tendons or ligaments. The wound 111 may also be any tissue that is not necessarily injured or defected, but instead is an area in which it is desired to add or promote growth of additional tissue.

[0022] As used herein, an "infecting organism" is a micro-organism (bacteria, fungi, protists, archaea, virus) that can cause wound infection. Non-limiting examples include *Staphylococcus aureus*, *Streptococcus pyrogenes*, *Escherichia coli*, *Pseudomonas aeruginosa*, *Proteus mirabilis*, *Klebsiella pneumoniae*, *Candida albicans* and *Bacteroides fragilis*. This includes (a) specific biotypes of a particular species or genus that has a particular characteristic or makes a particular product, where the characteristic or product can be detected by testing, e.g. *S. aureus* producing toxic shock syndrome toxin-1 (TSST-1); coagulase-negative staphylococci, or Group D streptococci; and (b) a group that has more than one species, e.g., Gram negative bacteria, *Corynebacterium* spp., Enterococci, *Enterobacter* spp., *Streptococcus* spp. In some embodiments, the infecting organism or group of organisms is a bacterium.

[0023] As used herein, a "product of an infection" is a specifically identifiable compound produced by either the host (i.e., patient) or the infecting organism during an infection. The host product might also be made when not infected, but for such a product to be useful in the present methods, it

should be produced in higher quantities in the fluid drawn from the wound during infection than fluid drawn from an uninfected wound. Nonlimiting examples of products of an infection include adenosine-5'-triphosphate (ATP) (made by bacteria) and certain cytokines, fibronectin fragments, neutrophil proteases, and macrophage protease (made by the host). A specifically identifiable compound is a compound that can be identified individually by its chemical composition or reactivity to a particular reagent such as an antibody or a nucleic acid probe of a particular sequence.

[0024] The drape 116 of the dressing 108 may be any material that provides a fluid seal. The drape 116 may, for example, be an impermeable or semi-permeable, elastomeric material. "Elastomeric" means having the properties of an elastomer. It generally refers to a polymeric material that has rubber-like properties. More specifically, most elastomers have elongation rates greater than 100% and a significant amount of resilience. The resilience of a material refers to the material's ability to recover from an elastic deformation. Examples of elastomers may include, but are not limited to, natural rubbers, polyisoprene, styrene butadiene rubber, chloroprene rubber, polybutadiene, nitrile rubber, butyl rubber, ethylene propylene rubber, ethylene propylene diene monomer, chlorosulfonated polyethylene, polysulfide rubber, polyurethane, EVA film, co-polyester, and silicones. Specific examples of drape 116 materials include a silicone drape, 3M Tegaderm® drape, acrylic drape such as one available from Avery Dennison, or an incise drape. The drape 116 can include an aperture 131 in which interface 133 is inserted. The interface 133 provides fluid communication between the conduit 122 and the sealed space formed by the drape 116.

[0025] The term "pad" as used herein generally refers to a substance or structure that is provided to assist in applying reduced pressure to, delivering fluids to, or removing fluids from a tissue site 110. The pad 112 typically includes a plurality of flow channels or pathways that distribute fluids provided to and removed from the tissue site 110 around the pad 112. In one illustrative embodiment, the flow channels or pathways are interconnected to improve distribution of fluids provided or removed from the tissue site 110. The pad 112 may be a biocompatible material that is capable of being placed in contact with the tissue site 110 and distributing reduced pressure to the tissue site 110. Examples of pads 112 may include, for example, without limitation, devices that have structural elements arranged to form flow channels, such as, for example, cellular foam, open-cell foam, porous tissue collections, liquids, gels, and foams that include, or cure to include, flow channels. The pad 112 may be porous and may be made from foam, gauze, felted mat, or any other material suited to a particular biological application. In one embodiment, the pad 112 is a porous foam and includes a plurality of interconnected cells or pores that act as flow channels. The porous foam may be a polyurethane, open-cell, reticulated foam such as GranuFoam® material manufactured by Kinetic Concepts, Incorporated of San Antonio, Texas. Other embodiments might include "closed cells." These closed-cell portions of the pad 112 may contain a plurality of cells, the majority of which are not fluidly connected to adjacent cells. The closed cells may be selectively disposed in the pad 112 to prevent transmission of fluids through perimeter surfaces of the pad 112. In some situations, the pad 112 may also be used to distribute fluids such as medications, antibacterials, growth factors, and various solutions to the tissue site 110. Other

layers may be included in or on the pad **112**, such as absorptive materials, wicking materials, hydrophobic materials, and hydrophilic materials

[0026] In some embodiments, the pad **112** includes a compound that reacts with a component of an infecting organism or a product of the infection in the wound **111**. As discussed above, the product of the infection can be either from the host (e.g., a compound such as a host protein produced in response to infection, for example a cytokine, a fibronectin fragment, a neutrophil protease, or a macrophage protease) or from the organism (e.g., ATP). In these embodiments, the product of the reaction between the compound and the component of the infecting organism or the product of the infection is drawn into the conduit **122** and detected by the device **118**. The device **118** may then notify a data processing system **126**, such as a computer, when the product of the reaction is detected via a communications connection **124**. The communications connection **124** includes both wire and wireless forms of communication. The data processing system **126** stores the data and may perform calculations to, e.g., calculate the concentration of the measured component or product, or the extent of the infection.

[0027] In another embodiment, the device **118** has the reacting compound to detect the component of an infecting organism or a product of the infection; in this embodiment, fluid from the wound **111** is pulled through the pad **112**, and into the device **118** to bring the fluid into the presence of the compound. The device **118** may also have the means for measuring the results of the reaction (e.g., charged coupled device [CCD] camera to measure the results from a microarray, chemistry chip or microfluidics device, or photodetector to measure light from the luciferase reaction).

[0028] A common product of bacterial infection that may be detected in the illustrative embodiments is adenosine-5'-triphosphate (ATP). In these methods, ATP may be detected by any means known in the art. In some embodiments, ATP is detected using the following luciferase-luciferin reaction, in the presence of Mg^{+2} :

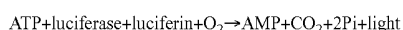

The light may be visualized, and optionally quantified, using, for example, a photodetector. In one embodiment, the device **118** is a photodetector.

[0029] Thus, in some embodiments, the ATP is detected by combining the fluid withdrawn from the wound **111** or an extract thereof with luciferase and luciferin, then measuring the light produced in an ensuing reaction. If the light produced exceeds the light produced by a wound that is not infected, then the wound **111** is infected. In various embodiments, the ATP is quantified by measuring the emitted light, where an increasing amount of ATP in the withdrawn fluid or extract thereof indicates an infection of the wound **111** of increasing severity. See, e.g., U.S. Pat. Nos. 4,833,075; 5,756,303; and 5,916,802 and European patent application 0025351 A1 for examples of methods of quantifying ATP to determine the presence of bacteria in a liquid.

[0030] In other embodiments, the product of the infection is a host protein associated with an inflammatory response. Any such host protein may be detected by the device **118** in these embodiments. In some of these embodiments, the host protein is a cytokine, a fibronectin fragment, a neutrophil protease, or a macrophage protease. See, e.g., PCT patent publication WO 2004/086043 and U.S. Patent Application Publication US 2005/0079542 A1.

[0031] The device **118** can also determine an infection in the wound fluid or extract by assaying for a component of an infecting organism or group of organisms. As used herein, a "component of an infecting organism" is a specifically identifiable piece of an organism capable of causing a wound infection. Nonlimiting examples of such components are lipopolysaccharide (LPS), lipoteichoic acid (LTA), antigens, and DNA having a particular sequence that is characteristic of a specific organism.

[0032] In certain embodiments where Gram negative bacteria is to be assayed, the withdrawn fluid or extract thereof is combined with a limulus amoebocyte lysate, which is sensitive for the lipopolysaccharide (LPS) of Gram negative bacteria. LPS can also be detected, e.g., with antibodies by known immunoassays, including assays that measure endotoxin activity by the priming host neutrophil respiratory burst activity via complement opsonized LPS-IgM immune complexes, such as the Endotoxin Activity Assay™ (Hilmi et al., J. Organ Dysfunction, advanced online publication, 23 Mar. 2009).

[0033] In various embodiments where Gram positive bacteria is to be assayed, a component to be assayed is lipoteichoic acid (LTA), which is detected by any means known in the art. In some of these embodiments, the LTA is detected with an assay comprising combining the withdrawn fluid or extract thereof with an antibody that specifically binds to LTA, then determining whether the antibody has bound to LTA.

[0034] In some embodiments, the wound fluid or extract thereof is tested for at least one specific genus or species of organism capable of causing a wound infection, e.g. *Streptococcus* sp., or *Streptococcus pyrogenes*. Such tests are desirable when the organism is identified to determine an infection treatment that affects a narrow host range, e.g., when an antibiotic is to be used that has a narrow host target range.

[0035] In some embodiments, assaying for a specific genus or species of organism capable of causing a wound infection involves the device **118** identifying, in an extract of the wound fluid, a nucleic acid sequence that is specific for an organism or group of organisms. In some of these methods, the withdrawn fluid is treated to release DNA or RNA from an infecting organism; the DNA, or a cDNA reverse-transcribed from the RNA, is labeled with a detectable label and applied to at least one immobilized nucleic acid specific for the at least one specific organism or group of organisms; and the immobilized nucleic acid is evaluated to determine whether the detectable label is specifically bound thereto. Here, the specific binding of the detectable label to the immobilized nucleic acid indicates that the wound **111** is infected with the specific organism or group of organisms. It is contemplated that microarrays or microfluidics chips can be used for these tests. See, e.g., Affymetrix (2005) Application Notes, Microarray Applications in Infectious Disease, at www.affymetrix.com. In some aspects of these embodiments, the labeled DNA or cDNA is applied to a microarray comprising at least five, ten, twenty, fifty or one hundred immobilized nucleic acids, each nucleic acid specific for a different organism or group of organisms capable of causing a wound infection.

[0036] In other embodiments, antibodies or aptamers are used to detect an antigen or aptamer binding site on the organism or group of organisms. In some of these embodiments, the withdrawn fluid or extract thereof is combined with an antibody or aptamer specific for a genus or species of organism or group of organisms, and the antibody or aptamer is then

evaluated to determine whether an antigen from the wound 111 is bound to the antibody or aptamer. Further, multiple antibodies or aptamers can be used to assay for multiple organisms. Thus, in some of these methods, the withdrawn fluid or extract thereof is combined with more than one antibody or aptamer, each antibody or aptamer specific for a different genus or species of organism capable of causing a wound infection; and the more than one antibody or aptamer is then evaluated to determine whether any of the more than one antibody or aptamer is bound to an antigen or aptamer binding site from the wound.

[0037] Numerous assays are known in the art for determining whether an antibody or aptamer is bound to an antigen or aptamer binding site. Examples include ELISA, western blot, and the assays described in U.S. Patent Application Publication US 2007/0292397 A1, incorporated herein by reference.

[0038] In one embodiment, the device 118 includes a compartment (not shown) for placing a substrate (not shown) comprising bound antibodies such that the fluid flows onto the antibodies as the fluid is drawn from the wound 111. These methods are not limited to any particular substrate for the device 118. Examples include polystyrene microtiter plates, nitrocellulose paper, and microchips. In further embodiments, the device comprises a limulus amoebocyte lysate.

[0039] One method for detecting infection in the wound 111 includes subjecting the wound 111 to reduced pressure sufficient to withdraw fluid from the wound 111. The fluid from the wound 111 may be collected in the device 118 or elsewhere, and the withdrawn fluid or an extract thereof may be assayed for a product of the infection or a component of the infecting organism or group of organisms. The presence of the product or component indicates infection in the wound 111. The illustrative embodiments can allow testing of the wound 111 for infection without removal of the dressing 108 for the wound, and detect specific organisms or groups of organisms.

[0040] In an alternative embodiment, the system 100 further comprises a reservoir (not shown) adapted for collection of the wound fluids. Such a reservoir may be used to collect fluids that are tested using a separate component of the system 100, such as the device 118. In another example, the device 118 or the reduced-pressure source 128 may have such a reservoir.

[0041] FIG. 2 shows an illustrative embodiment of a reduced-pressure treatment system 200 that includes a reduced-pressure source 228 that comprises a port 230 for a chip 235. The chip 235 may be a microfluidics or microarray or chemistry chip, as well as a detector (e.g., a CCD camera). The chip 235 may be used for detecting specific antigens or nucleic acids characteristic of an organism or group of organisms. The wound fluid is drawn through the conduit 122 to interact with the chip 235 in the port 230. The outlet 237 of the conduit 122 delivers the wound fluid to the chip 235 so that the chip 235 can interact with the wound fluid. The reduced-pressure source 228 can be configured to analyze the microarray or microfluidic data. In some embodiments using microarrays, the labeled DNA or cDNA is applied to a microarray comprising at least five, ten, twenty, fifty or one hundred immobilized nucleic acids, each nucleic acid specific for a different organism or group of organisms capable of causing a wound infection. Excess fluid is then removed through waste conduit 236.

[0042] Optionally, the system 200 may also have the device 118 and the communications cable 224. The device 118 or

separate data processing system (not shown) can be configured to analyze the microarray or microfluidic data. In the system 200, two measurements can be made on the wound fluid—from the device 118 and from the chip 235 in the port 230.

[0043] FIG. 3 is an illustrative embodiment of a reduced-pressure treatment system 300 that includes a pad 312 impregnated with luciferase and luciferin 334. In some embodiments, the luciferase is covalently bound to the pad 312, e.g., as described in U.S. Pat. No. 4,833,075. The reduced-pressure source 128 draws ATP from an infection in the wound 111 into the pad 312, and the ATP reacts with the luciferase and luciferin 334 to generate light. The light generated by the ATP/luciferase/luciferin reaction is detected by the device 318, which comprises a photodetector, and the light measurement is optionally transmitted to the data processing system 126 via the communications connection 124. The data processing system 126 can then record the light measurements. In this manner, the detection of light by the device 318 indicates the presence of ATP in the wound 111.

[0044] The device 318 is shown to be integrated with the drape 116. However, the device 318 may be located anywhere in the system 300 at which light from the ATP/luciferase/luciferin reaction can be detected.

[0045] In some embodiments, the system 300 further comprises a supply line 345 fluidly connected to the pad 312 for the introduction of luciferase and/or luciferin 334 from a reservoir 347. The supply line 345 may also be used to provide an infection-controlling compound to the wound 111, in which case the reservoir 347 includes such a compound.

[0046] It should be apparent from the foregoing that an invention having significant advantages has been provided. While the invention is shown in only a few of its forms, it is not just limited but is susceptible to various changes and modifications without departing from the spirit thereof.

[0047] All references cited in this specification are hereby incorporated by reference. The discussion of the references herein is intended merely to summarize the assertions made by the authors and no admission is made that any reference constitutes prior art. Applicants reserve the right to challenge the accuracy and pertinence of the cited references.

We claim:

1. A method of detecting infection in a wound caused by an infecting organism at a wound site, the method comprising:
 - applying a reduced pressure to the wound site;
 - withdrawing fluid from the wound site in response to the reduced pressure;
 - collecting the fluid withdrawn from the wound site; and
 - assaying the fluid collected from the wound site for a product of the infection or a component of the infecting organism;whereby the presence of the product or the component indicates the presence of an infection in the wound.
2. The method of claim 1, wherein the infecting organism is a bacterium.
3. The method of claim 1, wherein the wound comprises a tissue selected from the group consisting of dermal tissue, bone tissue, cartilage, tendon, ligament, muscle, nerve tissue, subcutaneous tissue, and adipose tissue.
4. The method of claim 1, wherein the fluid withdrawn is assayed for the product of the infection.
5. The method of claim 4, wherein the product of the infection is adenosine-5'-triphosphate (ATP).

6. The method of claim 5, wherein the ATP is detected by combining the fluid withdrawn with luciferase and luciferin, then measuring the light produced, wherein if light is produced above levels produced by a fluid from a wound that is not infected, then the wound is infected.

7. The method of claim 5, wherein the ATP is quantified, wherein an increasing amount of ATP in the fluid withdrawn indicates an infection of the wound of increasing severity.

8. The method of claim 4, wherein the product of the infection is a host protein associated with an inflammatory response.

9. The method of claim 8, wherein the host protein is a cytokine, a fibronectin fragment, a neutrophil protease, or a macrophage protease.

10. The method of claim 1, wherein the fluid withdrawn is assayed for the component of an infecting organism.

11. The method of claim 10, wherein the component of the infecting organism assayed is lipopolysaccharide (LPS) of Gram negative bacteria, which is detected with an assay comprising combining the fluid withdrawn with a limulus amoebocyte lysate or by an assay that primes host neutrophil respiratory burst activity via complement opsonized LPS-IgM immune complexes.

12. The method of claim 10, wherein the component of the infecting organism assayed is lipoteichoic acid (LTA) of Gram positive bacteria, which is detected with an assay comprising combining the fluid withdrawn with an antibody that specifically binds to LTA, then determining whether the antibody has bound to LTA.

13. The method of claim 10, wherein the fluid withdrawn is assayed for a component of at least one specific genus or species of organism capable of causing a wound infection.

14. The method of claim 13, wherein

the fluid withdrawn is treated to release DNA or RNA from the infecting organism;

the DNA, or a cDNA reverse transcribed from the RNA, is labeled with a detectable label and applied to at least one immobilized nucleic acid specific for the at least one specific organism; and

the immobilized nucleic acid is evaluated to determine whether the detectable label is specifically bound thereto,

wherein the specific binding of the detectable label to the immobilized nucleic acid indicates that the wound is infected with the genus or species of organism.

15. The method of claim 14, wherein the labeled DNA or cDNA is applied to a microarray comprising at least twenty immobilized nucleic acids, each nucleic acid specific for a different genus or species of organism capable of causing a wound infection.

16. The method of claim 13, wherein

the fluid withdrawn is combined with an antibody or aptamer specific for the at least one specific genus or species of organism; and

the antibody or aptamer is evaluated to determine whether the antibody or aptamer is bound to an antigen or aptamer binding site from the wound.

17. The method of claim 16, wherein

the fluid withdrawn is combined with more than one antibody or aptamer, each antibody or aptamer specific for a different genus or species of organism capable of causing a wound infection; and

the more than one antibody or aptamer is then evaluated to determine whether any of the more than one antibody or aptamer is bound to an antigen or aptamer binding site from the wound.

18. The method of claim 1, wherein the reduced pressure is applied from an apparatus comprising:

a source of reduced pressure;

a porous pad adapted to deliver the reduced pressure to the wound site;

a drape adapted to provide a cover over the pad and the wound site; and

a conduit fluidly connecting the porous pad to the source of reduced pressure whereby fluid is withdrawn from the wound site in response to the reduced pressure.

19. The method of claim 18, wherein the apparatus further comprises a reservoir adapted for collection of the fluid.

20. The method of claim 18, wherein the porous pad comprises luciferase and luciferin and the apparatus further comprises a photodetector capable of measuring light emitting from the porous pad.

21. The method of claim 20, wherein the luciferase is covalently bound to the porous pad.

22. The method of claim 20, wherein the apparatus further comprises a computer linked to the photodetector, wherein the computer is capable of recording the light measurements from the photodetector.

23. The method of claim 22, wherein the computer is further capable of determining whether the recorded light measurements indicate infection in the wound.

24. The method of claim 20, wherein the apparatus further comprises a supply line into the porous pad for the introduction of an infection-controlling compound to the wound.

25. A system for detecting an infection in a wound at a wound site, the system comprising:

a source of reduced pressure;

a porous pad adapted to deliver the reduced pressure to the wound site;

a drape adapted to provide a substantially airtight cover over the pad and the wound site;

a conduit fluidly connecting the porous pad to the source of reduced pressure whereby fluid is withdrawn from the wound site in response to the reduced pressure; and

a device for analyzing the fluid withdrawn from the wound site to identify a product of the infection or a component of an infecting organism;

whereby the presence of the product or the component indicates the presence of an infection in the wound.

26. The system of claim 25, wherein the device comprises a photodetector and the pad further comprises luciferase and luciferin.

27. The system of claim 26, wherein the luciferase is covalently bound to the pad.

28. The system of claim 29, wherein the device comprises a compartment for placing a substrate comprising bound antibodies such that the fluid flows onto the antibodies as the fluid is drawn from the wound.

29. The system of claim 29, wherein the device comprises a limulus amoebocyte lysate.

30. The system of claim 29, wherein the device comprises a microfluidics chip, a chemistry chip or a microarray.

31. The system of claim **30**, wherein the microfluidics chip, chemistry chip or microarray is in the reduced pressure source.

32. The system of claim **30**, further comprising a computer capable of recording results from the analysis.

33. A porous pad adapted for distributing reduced pressure to a wound site, wherein the pad comprises luciferase.

34. The porous pad of claim **33**, wherein the luciferase is covalently bound to the pad.

35. The porous pad of claim **33**, further comprising luciferin.

* * * * *

专利名称(译)	在减压伤口治疗中检测感染		
公开(公告)号	US20090326416A1	公开(公告)日	2009-12-31
申请号	US12/477704	申请日	2009-06-03
[标]申请(专利权)人(译)	MCNULTY AMY KILPADI DEEPAK 哈金森GEORGE中号 价格NANCY		
申请(专利权)人(译)	MCNULTY AMY KILPADI DEEPAK 哈金森GEORGE中号 价格NANCY		
当前申请(专利权)人(译)	MCNULTY AMY KILPADI DEEPAK 哈金森GEORGE中号 价格NANCY		
[标]发明人	MCNULTY AMY KILPADI DEEPAK HUTCHINSON GEORGE M PRICE NANCY		
发明人	MCNULTY, AMY KILPADI, DEEPAK HUTCHINSON, GEORGE M. PRICE, NANCY		
IPC分类号	A61B5/00 A61M1/00 G01N33/53 C12Q1/66 C12Q1/68		
CPC分类号	A61B5/145 A61M1/0025 A61B5/1459 A61B5/445 A61L15/38 A61L15/425 A61M1/0088 A61M2202/20 A61M2205/3306 A61M2205/583 C12Q1/66 G01N33/56911 G01N33/6893 G01N2800/26 A61B5/0082 A61B19/08 C12Q1/04 C12Q1/37 C12Q1/689 A61B5/14546 A61B46/00 A61B5/1455 A61B2562/0233 A61F13/00063 A61F13/00068		
优先权	61/058819 2008-06-04 US 61/118161 2008-11-26 US		
其他公开文献	US8460892		
外部链接	Espacenet USPTO		

摘要(译)

提供一种检测由伤口部位的感染生物引起的伤口感染的方法。还提供了一种用于检测伤口部位的伤口感染的系统。另外，提供了包含荧光素酶的多孔垫。

