



US 20080249360A1

(19) **United States**

(12) **Patent Application Publication**  
**Li et al.**

(10) **Pub. No.: US 2008/0249360 A1**  
(43) **Pub. Date: Oct. 9, 2008**

(54) **MEDICAL WIRELESS CAPSULE-TYPE  
ENDOSCOPE SYSTEM**

(30) **Foreign Application Priority Data**

Feb. 28, 2004 (CN)..... 200410021933.5

(75) Inventors: **Xiangdong Li**, Chongqing (CN);  
**Jinshan Wang**, Chongqing (CN)

**Publication Classification**

(51) **Int. Cl.**  
*A61B 1/04* (2006.01)  
*A61B 1/06* (2006.01)  
*A61B 1/00* (2006.01)  
(52) **U.S. Cl.** ..... **600/118; 600/160; 600/109**

Correspondence Address:

**COLLEN IP**  
**THE HOLYOKE MANHATTAN BUILDING**  
**80 SOUTH HIGHLAND AVENUE**  
**OSSINING, NY 10562 (US)**

(57) **ABSTRACT**

A medical wireless capsule-type endoscope system comprises a swallowable wireless endoscope capsule (100A) and a portable image recording device (100B). The wireless endoscope capsule (100A) includes an image sensor (5), the first microprocessor (6) for transforming the image information into a compressed JPEG format, the first RF transceiver module (9) and an antenna (10). The portable image recording device (100B) includes an antenna (100F), the second RF transceiver module (13) and the second microprocessor (14). The system also includes a wireless terminal (100G) which is connected to a medical imaging workstation (100E) to exchange information between the system and the medical imaging workstation (100E).

(73) Assignee: **CHONGQING JINSHAN SCIENCE &  
TECHNOLOGY (GROUP) CO.,**  
Chongqing (CN)

(21) Appl. No.: **10/598,347**

(22) PCT Filed: **Feb. 24, 2005**

(86) PCT No.: **PCT/CN05/00220**

§ 371(c)(1),  
(2), (4) Date: **Aug. 24, 2006**

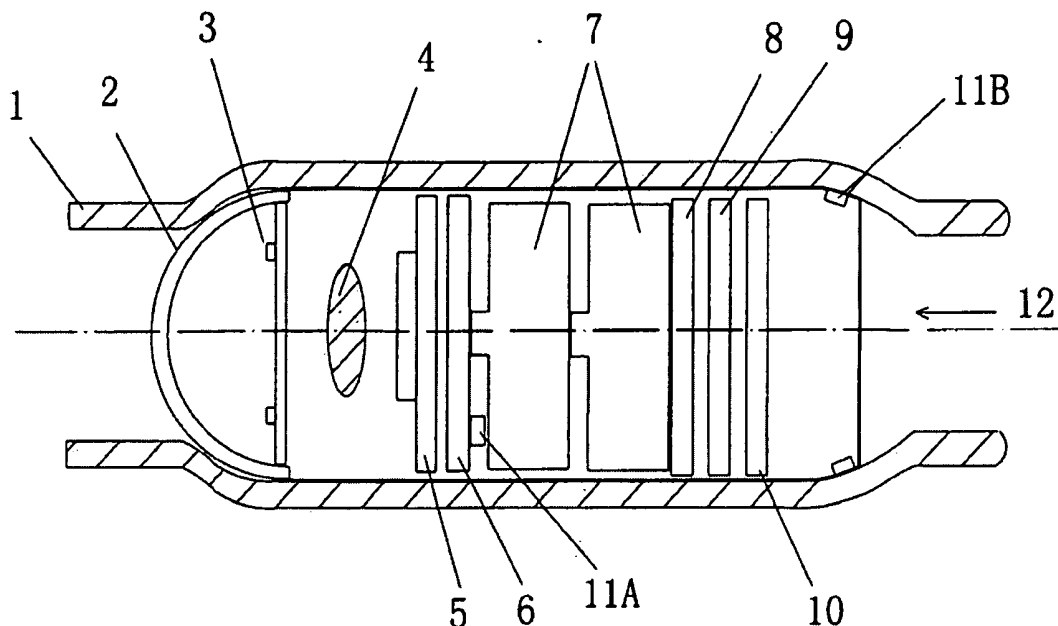

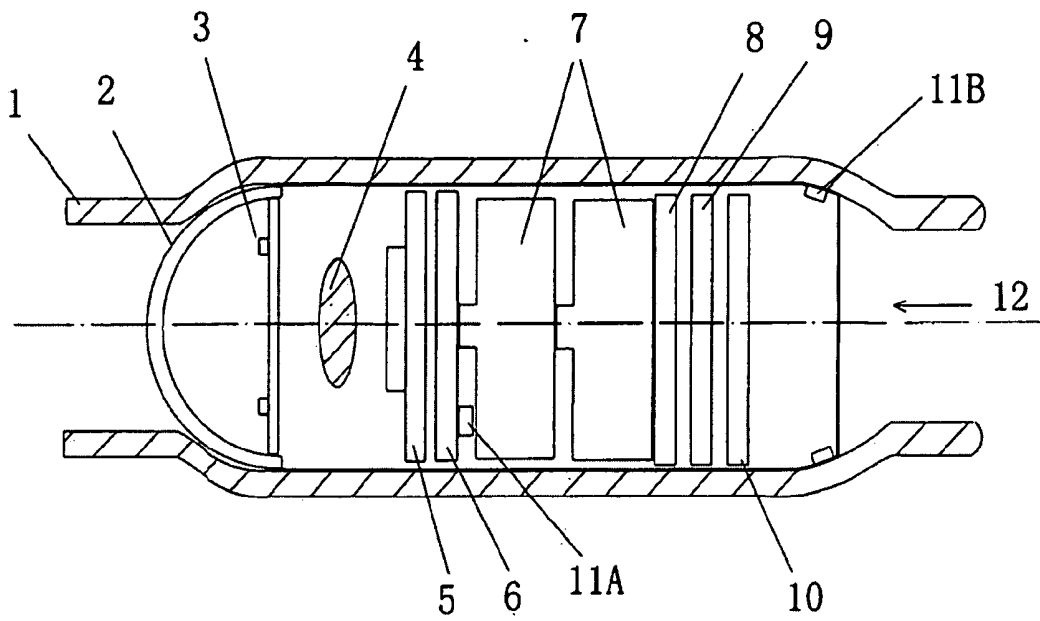

FIG. 1

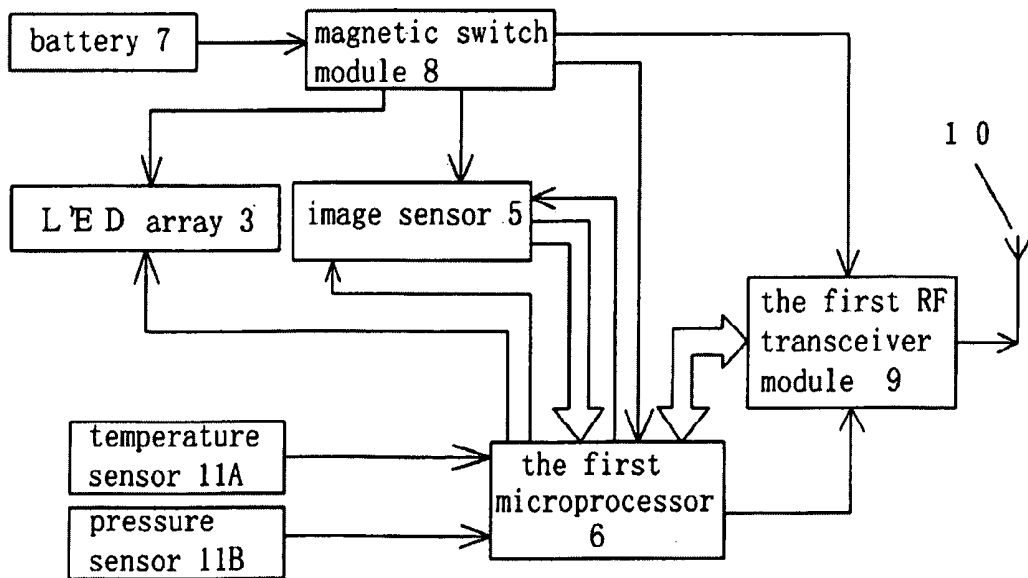

FIG. 2

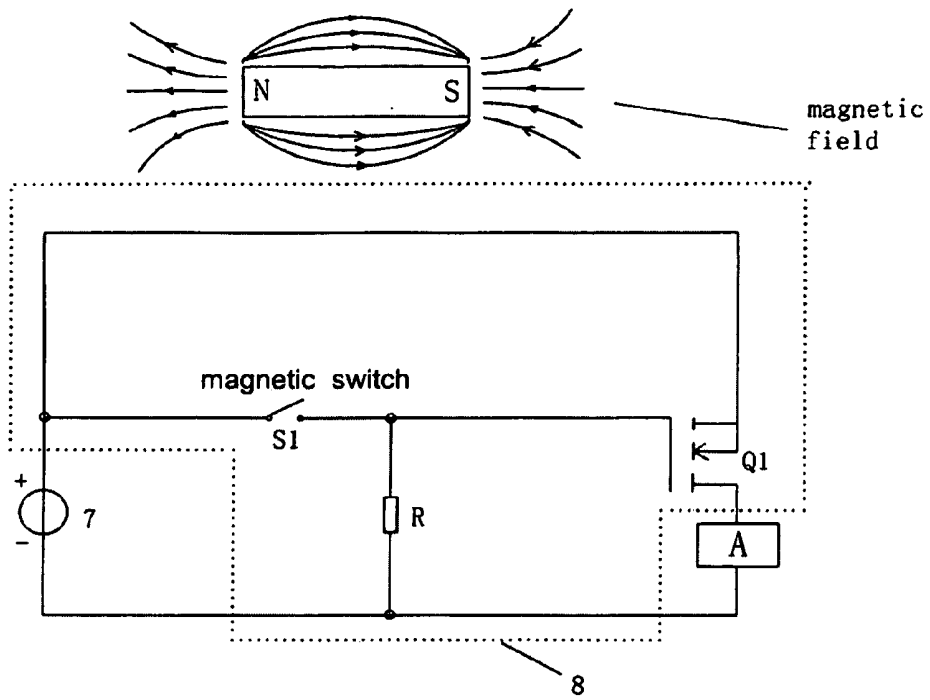

FIG. 3

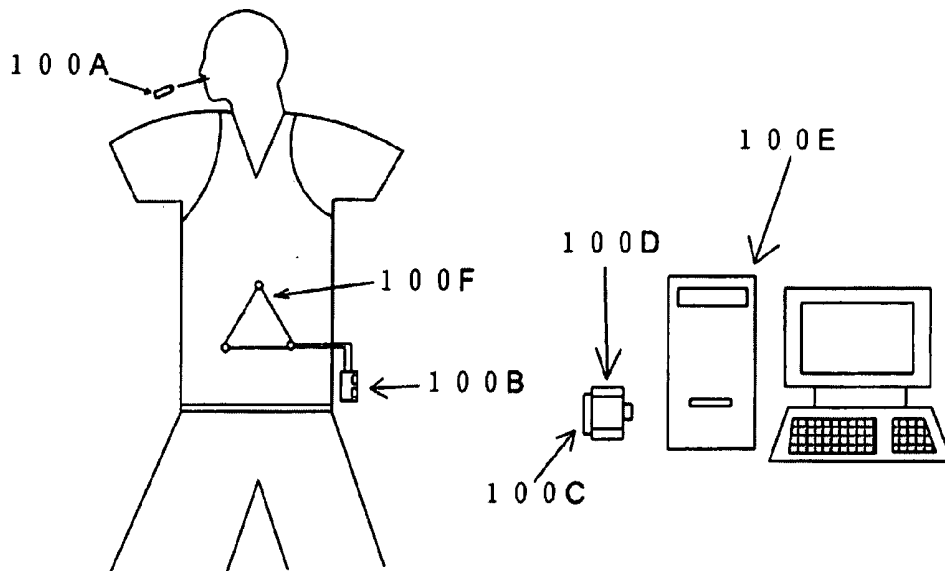

FIG. 4

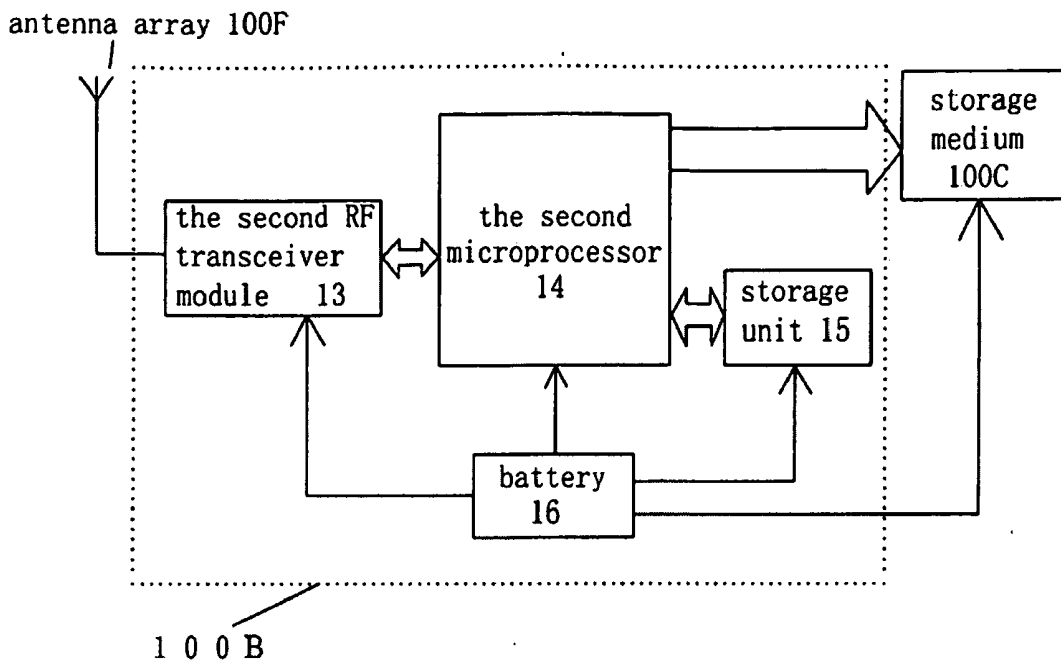

FIG. 5

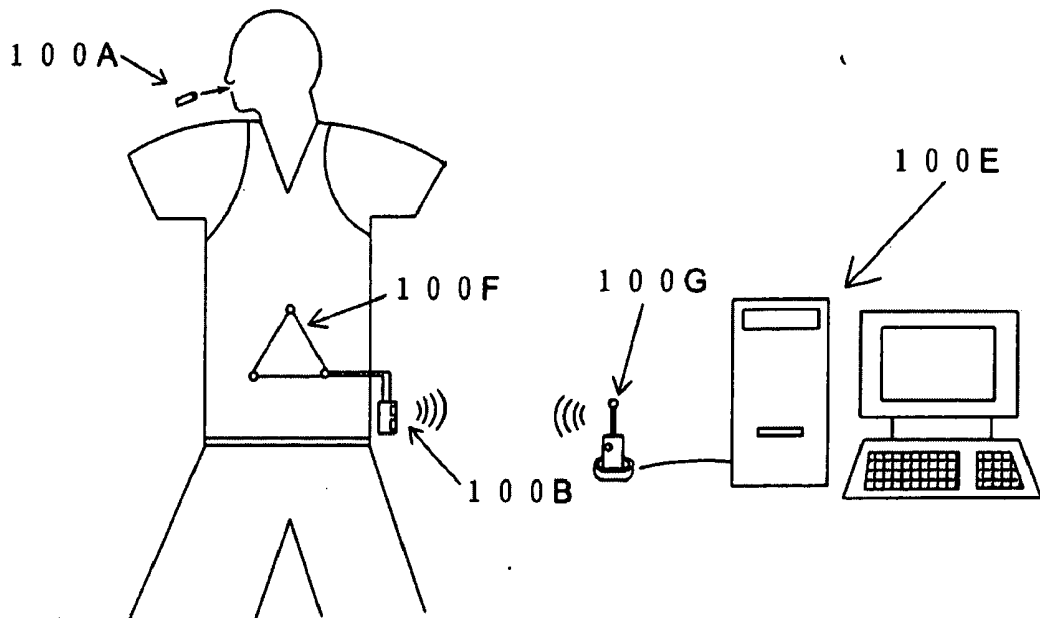
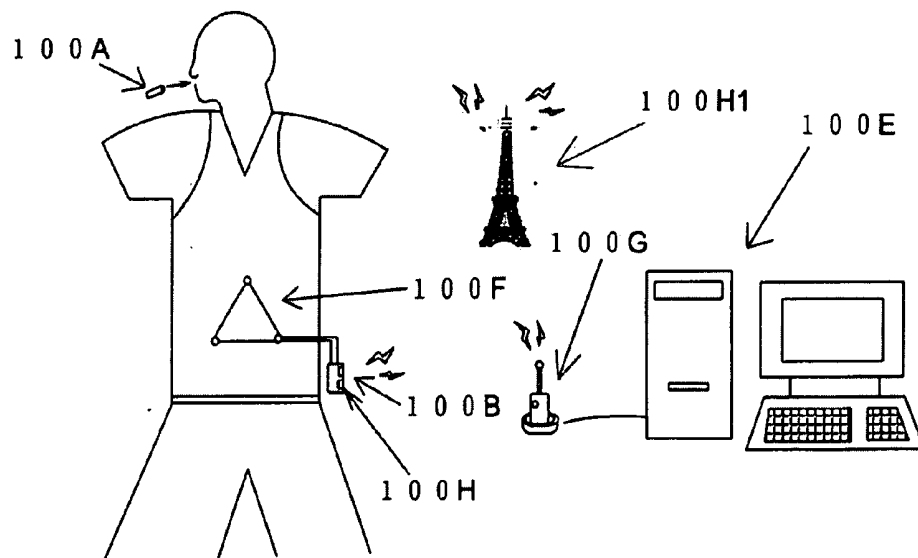
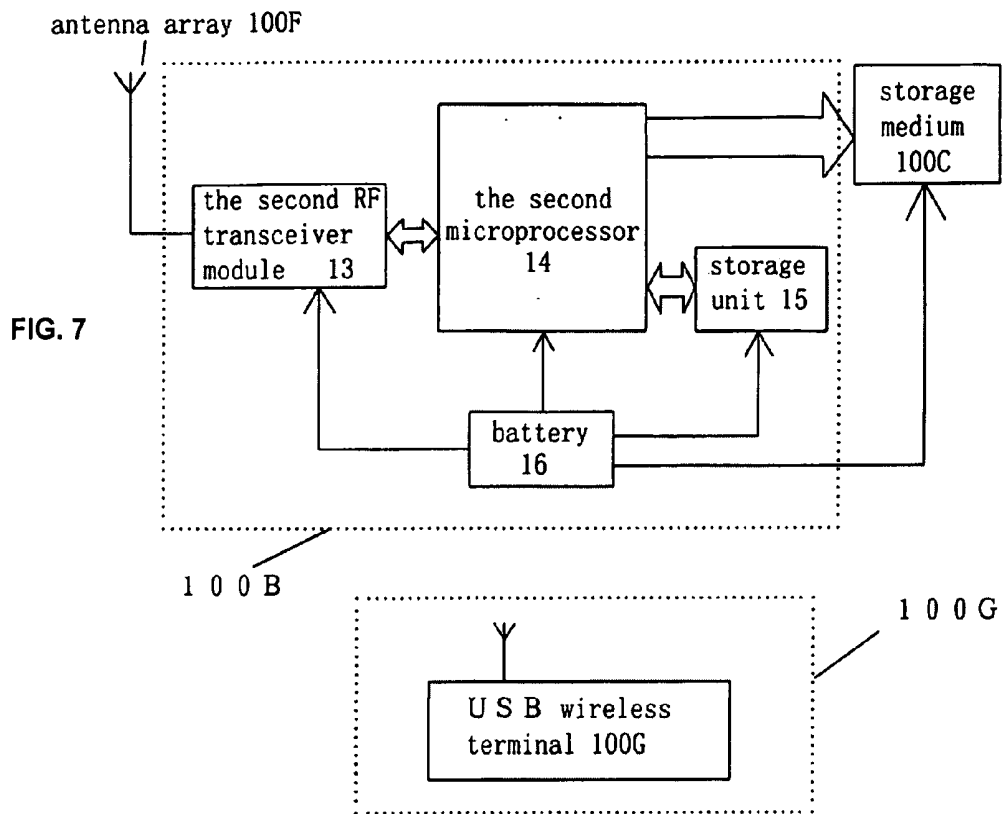

FIG. 6



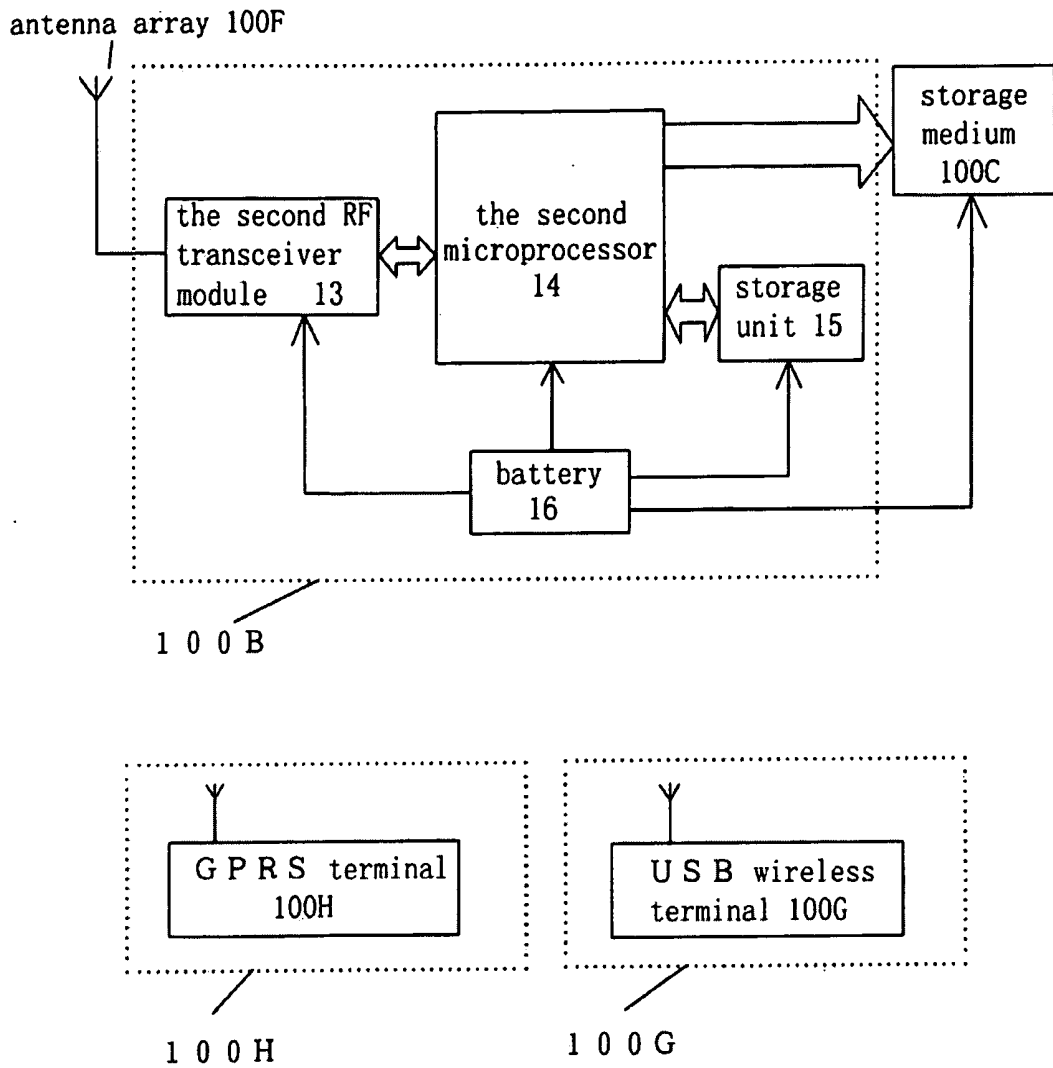

FIG. 9

## MEDICAL WIRELESS CAPSULE-TYPE ENDOSCOPE SYSTEM

### FIELD OF INVENTION

[0001] The present invention relates to a medical monitoring and inspecting system, and more particularly, to a medical wireless capsule-type endoscope system which is entered into the gastrointestinal tract for endoscopically observing.

### BACKGROUND OF THE INVENTION

[0002] Digestive endoscopes including gastroscopes, colonoscopes, duodenoscopes and small intestinoscopes not only have satisfactory visual field and strong controllability, but also could implement diagnostic biopsy, endoscopic ultrasonic inspection and various endoscopic treatment, such as microwave treatment, electrotomy treatment and the like. Therefore, the digestive endoscopes have become one of the most important endoscopically observing means for gastrointestinal tract diseases. However, the whole process of endoscopic check brings some pain and hurt to the subject, with the result that people fear the endoscopic check to some extent. Moreover, the existing gastroscopes, colonoscopes, duodenoscopes and small intestinoscopes could not conduct continuous complete check to the whole digestive tract except for particular parts.

[0003] An orally-taken capsule-type wireless endoscope system is disclosed in U.S. Pat. No. 5,604,531. Said orally-taken capsule is consist of a camera system, an optical system for imaging an area of interest onto said camera system and a transmitter which transmits the video output of said camera system. The patient needs to swallow such a capsule for checking the stomach and intestines. The capsule could be orally taken unpainfully due to its small volume, and no discomfort occurs after that. The micro camera in the capsule could continually send the recorded sharp image of the inner part of the intestines and stomach to the image recording device fixed at the subject's waist through the signal transmitter. The recording device is sent to the hospital after recording, where the doctors read and analyze the image data with aid of computers. Therefore, the conditions of the intestines and stomach could be known. A capsule could work over 6 hours. Upon finishing the desired task, the capsule will be entered into large intestines with the stomach and intestines peristalsis, and then excreted out of the body. The advantages of the capsule-type endoscope are apparent, such as small volume, easy administration and simple operation. In addition, the subject need not stay in hospital, and no complication disease is generated. Furthermore, the whole digestive tract could be checked, and the image data could be repeatedly reviewed and analyzed. However, said capsule-type endoscope still has some disadvantages as follows. The M2A-type capsule endoscope of GIVEN company of Israel with the operating modes of simplex, although it has the virtue of use handy, the effective check of capsule endoscope to the whole alimentary tract can not be achieved and the whole check process can not be controlled due to it can not adjust the sampling frequency of the capsule endoscope in real time. Therefore, some purposeful key checks can not be achieved.

### SUMMARY OF THE INVENTION

[0004] An object of the present invention is to provide a medical wireless capsule-type endoscope system which could not only wirelessly send digital image information outside, but also wirelessly receive control commands to control the operating modes of the capsule. A pressure sensor and a temperature sensor are contained in the system, so that the operating modes could be varied by control of the pressure values detected by the pressure sensor. Furthermore, the system could transport image information to the computerized medical image workstation and receive control commands from there through wired or wireless terminals.

[0005] In order to achieve the above goals, the present invention provides a medical wireless capsule-type endoscope system comprising a wireless endoscope capsule and a portable image recording device. The wireless endoscope capsule includes a housing, an optical front cover connected to the housing, a light emitting diode (LED) array arranged within the housing in sequence, a lens and a power switch module. The wireless endoscope capsule further includes an image sensor, the first microprocessor for transforming the image information into a compressed JPEG format, the first radio frequency (RF) transceiver module and a transceiver antenna. The signal output of the image sensor is connected with the I/O port of the first microprocessor. The image information received is transformed into the compressed JPEG format by the first microprocessor and then sent to the data receiving terminal of the first RF transceiver module. The information is sent to the portable image recording device via the antenna by the first RF transceiver module. After the control commands received from the image recording device by the antenna are sent by the first RF transceiver module to the first microprocessor for processing, the operating modes of the LED array, the image sensor and the first RF transceiver module are controlled by the I/O ports of the first microprocessor. The portable image recording device includes a transceiver antenna array, the second RF transceiver module, the second microprocessor and a storage unit connected with the bus thereof. The second RF transceiver module communicates the information received from the wireless endoscope capsule by the antenna array to the second microprocessor by the bus or sends the information from the control terminals of the second microprocessor to the wireless endoscope capsule by the antenna array.

[0006] The information from the control terminals of the second microprocessor of the portable image recording device is sent to the wireless terminal of computerized medical image workstation by the second RF transceiver module of the portable image recording device, and/or the information received from the wireless terminal of the computerized medical image workstation by the antenna array is sent by the wireless transceiver module of the portable image recording device to the second microprocessor by the bus for processing, and then sent to the wireless endoscope capsule.

[0007] The technical effects generated by the configuration of the invention are apparent. There is no fear for the subject to take the wireless endoscope capsule due to its small value and light weight. The wireless endoscope capsule takes no affect on walk and daily activity of the subject during check and is simple to operate. In addition, the subject need not stay

in hospital, and no complication disease is generated. Furthermore, the whole digestive tract could be checked, and the image data could be repeatedly reviewed and analyzed by the doctors. Particularly, said wireless endoscope capsule could be controlled from outside at any moment during check. The operating modes of the wireless endoscope capsule could be managed by detection pressure. The wireless endoscope capsule system could not only wirelessly send the image of the digestive tract to the portable image recording device, but also send the temperature and pressure information of the digestive tract to the portable image recording device in real time. Moreover, the wireless endoscope capsule system could exchange information with the computerized medical image workstation by the wireless terminal.

#### BRIEF DESCRIPTION OF THE DRAWINGS

[0008] The present invention will become more fully understood from the detailed description given herein below for illustration only, and thus are not limitative of the present invention, and wherein:

[0009] FIG. 1 is a sectional structural view of the wireless endoscope capsule;

[0010] FIG. 2 is a schematic circuit diagram of one embodiment of the wireless endoscope capsule;

[0011] FIG. 3 is a schematic circuit diagram of the magnetic switch module of the wireless endoscope capsule;

[0012] FIG. 4 is a schematic view of the first embodiment of the invention;

[0013] FIG. 5 is a schematic diagram of the portable image recording device according to the first embodiment of the invention;

[0014] FIG. 6 is a schematic view of the second embodiment of the invention;

[0015] FIG. 7 is a schematic diagram of the portable image recording device according to the second embodiment of the invention;

[0016] FIG. 8 is a schematic view of the third embodiment of the invention; and

[0017] FIG. 9 is a schematic diagram of the portable image recording device according to the third embodiment of the invention.

[0018] In the above mentioned drawings:

- [0019] 100A: wireless endoscope capsule
- [0020] 100B: portable image recording device
- [0021] 100C: storage medium
- [0022] 100D: storage medium reader
- [0023] 100E: computerized medical image workstation
- [0024] 100F: antenna array of portable image recording device
- [0025] 100G: USB wireless terminal
- [0026] 100H: GPRS, CDMA, GSM or WLAN terminal
- [0027] 100H1: GPRS mobile network
- [0028] 1: gastrointestinal tract

- [0029] 2: optical front cover
- [0030] 3: LED array
- [0031] 4: optical lens
- [0032] 5: image sensor
- [0033] 6: the first microprocessor
- [0034] 7: battery
- [0035] 8: power switch module
- [0036] 9: the first RF transceiver module
- [0037] 10: antenna
- [0038] 11A: temperature sensor
- [0039] 11B: pressure sensor
- [0040] 12: housing
- [0041] 13: the second RF transceiver module
- [0042] 14: the second microprocessor
- [0043] 15: storage unit
- [0044] 16: power supply
- [0045] A: the LED array 3, the image sensor 5, the first microprocessor 6 and the first RF transceiver module 9 of the wireless endoscope capsule 100A

#### DETAILED DESCRIPTION OF THE INVENTION

[0046] The medical wireless capsule-type endoscope system of the present invention includes a wireless endoscope capsule 100A, a portable image recording device 100B and the antenna array 100F thereof, a wireless terminal connected with the computerized medical image workstation 100E, a storage medium 100C and a storage medium reader 100D. The antenna array 100F consists of wireless receiving units, which is fixed around the abdomen of the subject by a specified vest. The antenna array 100F facilitates receiving the data sent by the wireless endoscope capsule 100A, and provides information for positioning the wireless endoscope capsule 100A in the subject body.

[0047] FIG. 1 shows a sectional structural view of one embodiment of the wireless endoscope capsule 100A within the gastrointestinal tract 1. From left to right, the wireless endoscope capsule 100A includes an optical front cover 2, a white light-emitting LED array 3, a lens 4, an image sensor 5, the first microprocessor 6, button battery 7, a magnetic switch module 8, regarded as power switch module, the first RF transceiver module 9 and an antenna 10. In this embodiment, the wireless endoscope capsule 100A further includes a temperature sensor 11A and/or a pressure sensor 11B. A housing 12 is adhered to the optical front cover 2 as one piece. The pressure sensor 11B is closely mounted on the inner wall of the housing 12.

[0048] The operational principle of said system is described as follows. The white light reflected by the inner wall of the gastrointestinal tract is passed through the optical front cover 2 and imaged on the photosensitive face of the image sensor 5 via the lens 4. Electrical signals are obtained by photoelectric conversion corresponding to the image of the inner wall of the gastrointestinal tract. Then, the electrical signals are subjected to signal processing, such as analog to digital conversion, image signal processing and JPEG encod-

ing and decoding, and stored in the first microprocessor 6 of the wireless endoscope capsule 100A. Finally, the first RF transceiver module 9 sends the resulting image information out or receives command information from outside.

[0049] Referring to FIG. 2, the image sensor 5 as shown could be embodied as CMOS (Complementary Metal Oxide Semiconductor) or CCD (Charged Coupled Device) image sensor, such as Image Sensor Module-VS6552 manufactured by ST Microelectronics. The first microprocessor MCU 6 could use MSP340 Series chips, and the first RF transceiver module 9 could use MK70110 chips. The outputs of the temperature sensor 11A and the pressure sensor 11B are connected to the I/O ports of the first microprocessor 6.

[0050] Referring to FIG. 3, the magnetic switch module 8 is switched on in the magnetic field, and after the magnet is removed, it is switched off. The magnetic switch module 8 includes a magnetically controlled switch S1 and a field effect tube Q1. When the switch S1 is switched on,  $V_{GS}$  of the field effect tube Q1 is equal to zero which is lower than the turn-on threshold voltage of the field effect tube Q1, so the field effect tube Q1 is turned off. In such a case, the field effect tube Q1 cuts the connection between the battery 7 and the load circuit A (the load circuit A means LED array 3, image sensor 5, the first microprocessor 6 and the first RF transceiver module 9 of the wireless endoscope capsule 100A), and the battery 7 can not supply power to the load circuit A. On the contrary, when the switch S1 is switched on,  $V_{GS}$  is equal to the battery voltage which is higher than the turn-on threshold voltage of the field effect tube Q1, so the field effect tube Q1 is turned on. In such a case, the battery 7 is connected with the load circuit A via the field effect tube Q1, and the battery 7 supplies power to the load circuit A.

[0051] The first embodiment of the invention is shown in FIGS. 4 and 5. The data exchange between the wireless endoscope capsule 100A powered on and the portable image recording device 100B should be accomplished firstly before use. The power-on process of the wireless endoscope capsule 100A means removing the magnet used to control the magnetic switch module 8 and switching on the loop of the wireless endoscope capsule 100A by the magnetic switch module 8 in the wireless endoscope capsule 100A. One purpose of the data exchange between the wireless endoscope capsule 100A powered on and the portable image recording device 100B is to check whether the wireless endoscope capsule 100A operates in the normal condition, and the other purpose is to accomplish downloading the configuration data of the wireless endoscope capsule 100A to the portable image recording device 100B. The configuration data of the wireless endoscope capsule 100A refers to the specific operating modes of the wireless endoscope capsule 100A, such as image resolution, image frame collection rate and exposure time. Whether the wireless endoscope capsule 100A operates in the normal condition could be determined by whether the configuration data is successfully downloaded. After the configuration data is downloaded successfully, the wireless endoscope capsule 100A enters the working state. According to the program in the first microprocessor 6 of the wireless endoscope capsule 100A, the images are shot in real time and the temperature of the wireless endoscope capsule 100A and the pressure applied thereon are recorded for further processing. Said processed information is sent to the portable image recording device 100B by way of wireless radio frequency.

[0052] After the wireless endoscope capsule 100A is orally taken by the subject, the micro camera system in the wireless endoscope capsule 100A could send the image, temperature and pressure of the inner wall of the human gastrointestinal tract 1, particularly the inner wall of small intestines, to the portable image recording device 100B worn by the subject by way of wireless RF transmission in a predetermined frame rate. The image, temperature and pressure information recorded in the storage medium 100C is read into the computerized medical image workstation 100E by the storage medium reader 100D for processing, displaying and analyzing.

[0053] The second embodiment of the invention is shown in FIGS. 6 and 7. The wireless endoscope capsule 100A is used in the same way as the first embodiment except the difference as follows. The information is sent by the portable image recording device 100B to the USB wireless terminal 100G connected with the computerized medical image workstation 100E by way of wireless radio frequency. Or the information is received by the portable image recording device 100B from the USB wireless terminal 100G connected with the computerized medical image workstation 100E by way of wireless radio frequency. After the information is received by the portable recording device 100B, it is processed by the second microprocessor 14 and then sent to the wireless endoscope capsule 100A by the antenna array 100F.

[0054] After the wireless endoscope capsule 100A is orally taken by the subject, the micro camera system in the wireless endoscope capsule 100A could send the image, temperature and pressure of the inner wall of the human gastrointestinal tract 1, particularly the inner wall of small intestines, to the portable image recording device 100B worn by the subject by way of wireless RF transmission in a predetermined frame rate. Then, the portable image recording device 100B sends said data to the USB wireless terminal 100G connected with the computerized medical image workstation 100E. In such a case, the image, temperature and pressure information of the human gastrointestinal tract 1 could be checked in real time by the doctors at the computerized medical image workstation 100E, and optionally, the operating modes of the wireless endoscope capsule 100A, such as image resolution, frame collection rate, exposure time, temperature sensing and pressure sensing, could be controlled in real time, so that as much as possible necessary information of the digestive tract is acquired. The second RF transceiver module 13 of the invention has a multi-channel working mode with up to 125 channels, and the switching speed between different channels is lower than 200  $\mu$ s. The wireless endoscope capsule system according to the second embodiment of the invention could be applied to check several patients simultaneously. Furthermore, the test data of the patients could be totally recorded in the computerized medical image workstation 100E for further processing, displaying and analyzing.

[0055] With reference to FIGS. 8 and 9, the wireless endoscope capsule system according to the third embodiment of the invention combines the benefits of the first embodiment with those of the second embodiment, in which the mobile application of the wireless endoscope capsule system could be achieved by GPRS (General Packet Radio Service) mobile network 100H1. On one hand, the wireless endoscope capsule system of the third embodiment has the mobility of the first embodiment, on the other hand, it could check and control the operating modes of the wireless endoscope capsule

**100A** in real time by GPRS mobile network **100H1**. The data exchange between the wireless endoscope capsule **100A** powered on and the portable image recording device **100B** should be accomplished firstly before use. Then, the portable image recording device **100B** exchanges data with the GPRS terminal **100H**. The GPRS terminal **100H** exchanges data with the USB wireless terminal **100G** of the computerized medical image workstation **100E** through GPRS mobile network **100H1**.

[0056] The system further includes a CDMA, GSM or WLAN terminal **100H**. The portable image recording device **100B** exchanges data with the CDMA, GSM or WLAN terminal **100H**, and said CDMA, GSM or WLAN terminal **100H** exchanges data with wireless terminal **100G** of the computerized medical image workstation **100E** through corresponding mobile network.

[0057] After the wireless endoscope capsule **100A** is orally taken by the subject, the micro camera system in the wireless endoscope capsule **100A** could send the image, temperature and pressure of the inner wall of the human gastrointestinal tract **1**, particularly the inner wall of small intestines, to the portable image recording device **100B** worn by the subject by way of wireless RF transmission in a predetermined frame rate. The portable image recording device **100B** exchanges the data with the GPRS terminal **100H**. Then, the GPRS terminal **100H** sends said data to the USB wireless terminal **100G** of the computerized medical image workstation **100E** by GPRS mobile network **100H1**. In such a case, the image, temperature and pressure information of the human gastrointestinal tract **1** could be checked in real time by the doctors at the computerized medical image workstation **100E**, and optionally, the operating modes of the wireless endoscope capsule **100A**, such as image resolution, frame collection rate, exposure time, temperature sensing and pressure sensing, could be controlled in real time, so that as much as possible necessary information of the digestive tract is acquired. The second RF transceiver module **13** of the invention has a multi-channel working mode with up to 125 channels, and the switching speed between different channels is lower than 200  $\mu$ s. The wireless endoscope capsule system according to the third embodiment of the invention could be adapted to prevent mutual interference between the wireless electrical signals emitted by the wireless endoscope capsules **100A** and the portable image recording devices **100B** worn by several subjects, thereby it could be used more freely. Therefore, several patients could be checked simultaneously, and the operating modes of the wireless endoscope capsule **100A** within the human body could be controlled by the doctors in real time. Furthermore, the test data of the patients could be totally recorded in the computerized medical image workstation **100E** for further processing, displaying and analyzing.

What is claimed is:

1. A medical wireless capsule-type endoscope system, comprising a wireless endoscope capsule (**100A**) and a portable image recording device (**100B**); the wireless endoscope capsule (**100A**) includes a housing (**12**), an optical front cover (**2**) connected to the housing (**12**), an LED array (**3**) arranged within the housing **X** in sequence, a lens (**4**) and a power switch module (**8**); characterized in that, the wireless endoscope capsule (**100A**) further includes an image sensor (**5**), the first microprocessor (**6**) for transforming the image information into a compressed JPEG format, the first RF transceiver module (**9**) and a transceiver antenna (**10**), wherein the

signal output of the image sensor (**5**) is connected with the I/O port of the first microprocessor **A**, the image information received is transformed into the compressed JPEG format by the first microprocessor (**6**) and then sent to the data receiving terminal of the first RF transceiver module (**9**), the information is sent to the portable image recording device (**100B**) via the antenna **C** by the first RF transceiver module (**9**) after the control commands received from the image recording device by the antenna (**10**) are sent by the first RF transceiver module (**9**) to the first microprocessor (**6**) for processing, the operating modes of the LED array (**3**), the image sensor (**5**) and the first RF transceiver module (**4**) are controlled by the I/O ports of the first microprocessor (**6**); the portable image recording device (**100B**) includes a transceiver antenna array (**100F**), the second RF transceiver module (**13**) the second microprocessor (**14**) and a storage unit (**15**) connected with the bus thereof, wherein the second RF transceiver module (**13**) communicates the information received from the wireless endoscope capsule (**100A**) by the antenna array (**100F**) to the second microprocessor (**14**) by the bus or sends the information from the control terminals of the second microprocessor (**WA**) to the wireless endoscope capsule (**100A**) by the antenna array (**100F**).

2. The medical wireless capsule-type endoscope system as claimed in claim 1, characterized in that, a temperature sensor (**11A**) and/or a pressure sensor (**11B**) are mounted within the housing (**12**) of the wireless endoscope capsule (**100A**), wherein the pressure sensor (**11B**) is closely mounted on the inner wall of the housing (**12**), and the outputs of the temperature sensor (**11A**) and the pressure sensor (**11B**) are connected to the I/O ports of the first microprocessor (**6**).

3. The medical wireless capsule-type endoscope system as claimed in claim 1, characterized in that, said system further includes a wireless terminal (**100G**) connected with the computerized medical image workstation (**100E**); the information from the control terminals of the second microprocessor (**14**) of the portable image recording device (**100B**) is sent to the wireless terminal (**100G**) of the computerized medical image workstation (**100E**) by the second RF transceiver module (**13**) of the portable image recording device (**100B**), and the information received from the wireless terminal (**100G**) of the computerized medical image workstation (**100E**) by the antenna array (**100F**) is sent by the wireless transceiver module (**13**) of the portable image recording device (**100B**) to the second microprocessor (**14**) by the bus for processing, and then sent to wireless endoscope capsule (**100A**).

4. The medical wireless capsule-type endoscope system as claimed in claim 1, characterized in that, said system also includes a GPRS terminal (**100H**) and a wireless terminal (**100G**) connected with the computerized medical image workstation (**100E**), the portable image recording device (**100B**) exchanges data with the GPRS terminal (**100H**), and the GPRS terminal (**100H**) exchanges data with wireless terminal (**100G**) of the computerized medical image workstation (**100E**) through GPRS mobile network (**100H1**).

5. The medical wireless capsule-type endoscope system as claimed in claim 3, characterized in that, said system further includes a storage medium reader (**100D**) wiredly connected with the computerized medical image workstation (**100E**) and a storage medium (**100C**), and the storage medium (**100C**) is connected with the second microprocessor (**14**) of the portable image recording device (**100B**) through the socket by the bus.

6. The medical wireless capsule-type endoscope system as claimed in claim 1, characterized in that, said power switch module (8) is magnetic switch module and the magnetically controlled switch (S1) of the magnetic switch module (8) is switched on in the magnetic field, and after the magnet is removed, it is switched off.

7. The medical wireless capsule-type endoscope system as claimed in claim 1, characterized in that, the system further includes a wireless terminal (100G) connected with the com-

puterized medical image workstation (100E) and a CDMA, GSM or WLAN terminal (100H); the portable image recording device (100B) exchanges data with the CDMA, GSM or WLAN terminal (100H), and said CDMA, GSM or WLAN terminal (100H) exchanges data with wireless terminal (100G) of the computerized medical image workstation (100E) through corresponding mobile network.

\* \* \* \* \*

专利名称(译)	医用无线胶囊型内窥镜系统		
公开(公告)号	<a href="#">US20080249360A1</a>	公开(公告)日	2008-10-09
申请号	US10/598347	申请日	2005-02-24
申请(专利权)人(译)	重庆金山科技科技(集团)有限公司.		
当前申请(专利权)人(译)	重庆金山科技学院学报(GROUP)CO.,LTD.		
[标]发明人	LI XIANGDONG WANG JINSHAN		
发明人	LI, XIANGDONG WANG, JINSHAN		
IPC分类号	A61B1/04 A61B1/06 A61B1/00 A61B1/05 A61B5/00 A61B5/03 A61B5/07 H04N7/18		
CPC分类号	A61B1/00016 A61B1/041 A61B5/0008 A61B5/0031 A61B5/03 A61B5/073 A61B2560/045		
优先权	200410021933.5 2004-02-28 CN		
外部链接	<a href="#">Espacenet</a> <a href="#">USPTO</a>		

摘要(译)

一种医用无线胶囊型内窥镜系统，包括可吞咽无线内窥镜胶囊(100A)和便携式图像记录装置(100B)。无线内窥镜胶囊(100A)包括图像传感器(5)，用于将图像信息转换为压缩JPEG格式的第一微处理器(6)，第一RF收发器模块(9)和天线(10)。便携式图像记录装置(100B)包括天线(100F)，第二RF收发器模块(13)和第二微处理器(14)。该系统还包括无线终端(100G)，其连接到医学成像工作站(100E)以在系统和医学成像工作站(100E)之间交换信息。

