



US 20040153008A1

(19) **United States**

(12) **Patent Application Publication**  
**Sharf et al.**

(10) **Pub. No.: US 2004/0153008 A1**

(43) **Pub. Date: Aug. 5, 2004**

(54) **PROBE ANCHOR**

**Related U.S. Application Data**

(76) Inventors: **Yehuda Sharf**, Tel Aviv (IL); **Moshe Betzalel**, Modiin (IL)

(60) Provisional application No. 60/295,569, filed on Jun. 5, 2001. Provisional application No. 60/295,573, filed on Jun. 5, 2001. Provisional application No. 60/309,783, filed on Aug. 6, 2001. Provisional application No. 60/338,671, filed on Dec. 11, 2001.

Correspondence Address:  
**William H Dippert**  
**Reed Smith**  
**29th Floor**  
**599 Lexington Avenue**  
**New York, NY 10022-7650 (US)**

**Publication Classification**

(51) **Int. Cl.<sup>7</sup>** ..... **A61B 5/103**

(52) **U.S. Cl.** ..... **600/588**

(57) **ABSTRACT**

A probe anchor that attaches a probe to a tissue adjacent a birth canal, comprising: (a) a soft tissue anchor including a release mechanism; (b) a cable sufficiently pliable that it will not harm a fetus during passage through the birth canal coupled at one end thereof to said release mechanism; and (c) a control coupled to an opposite end of said cable and operative to remotely release said release mechanism using said cable without requiring manual stabilization directly to said anchor.

(21) Appl. No.: **10/480,008**

(22) PCT Filed: **Jun. 5, 2002**

(86) PCT No.: **PCT/IL02/00441**

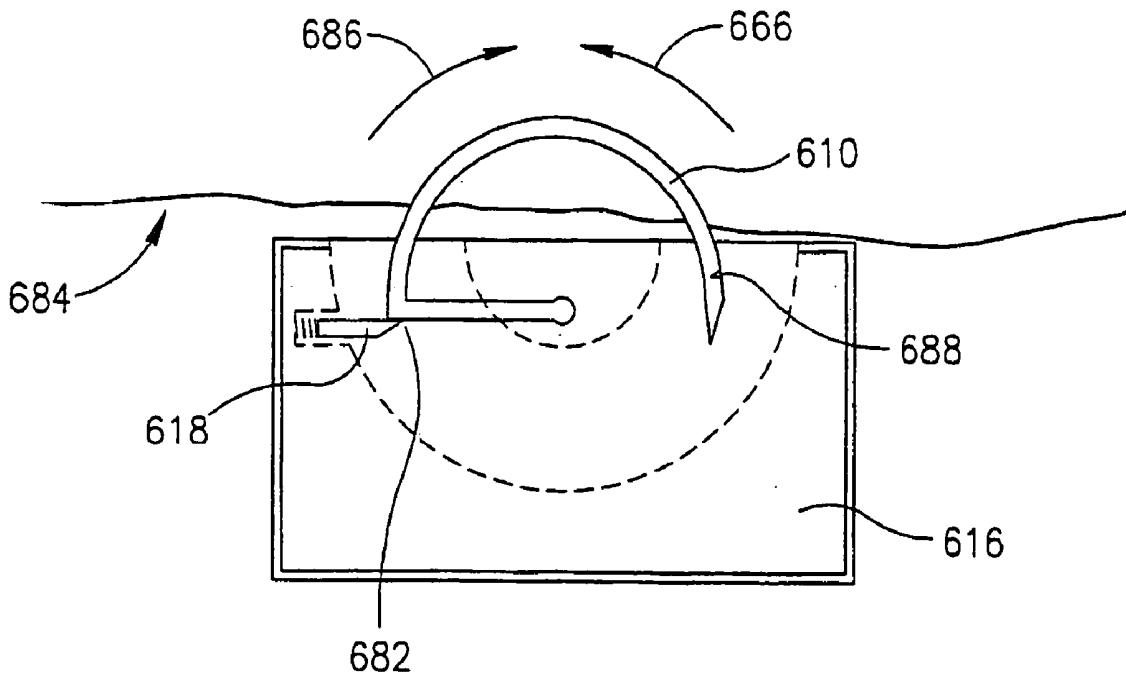

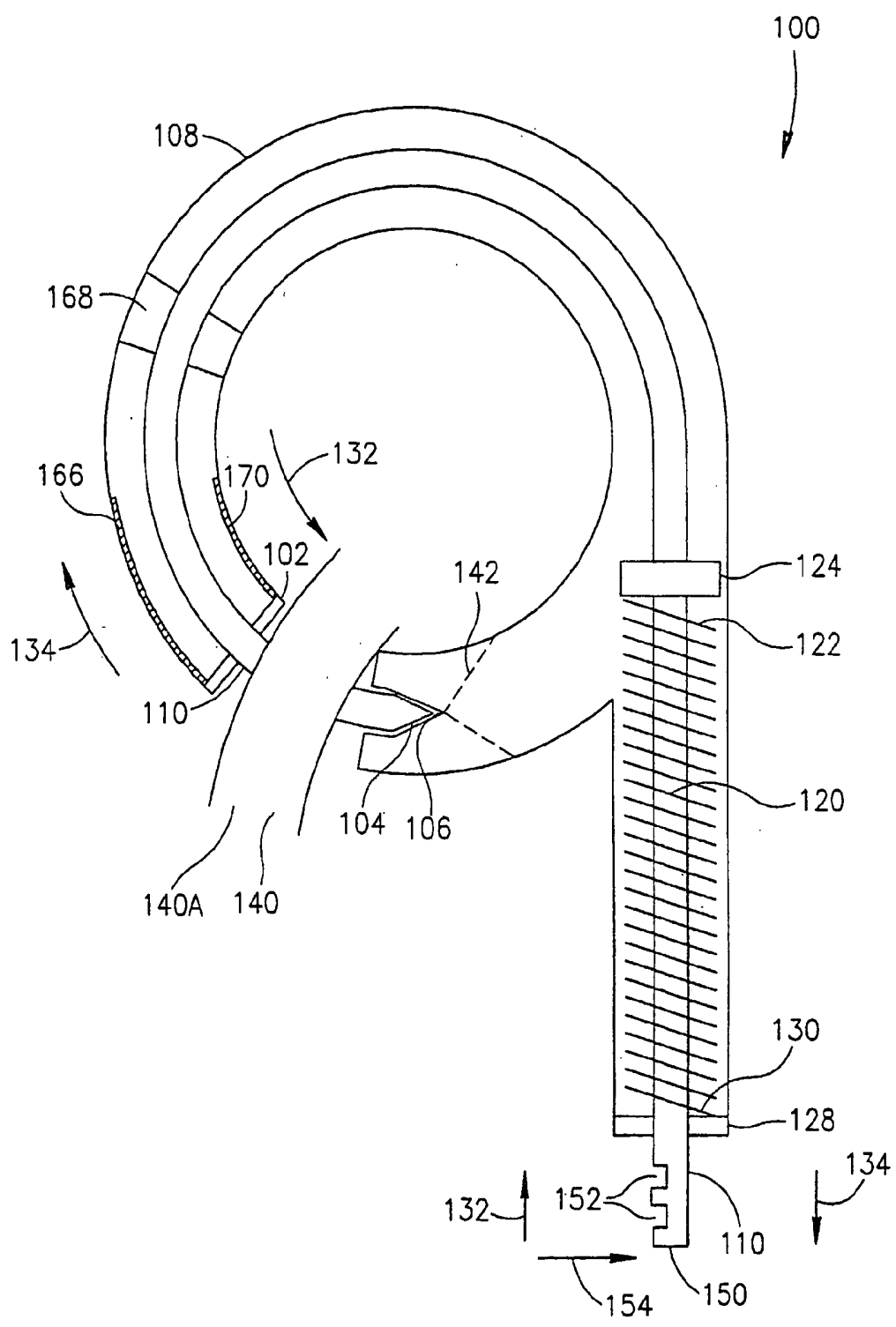

FIG.1

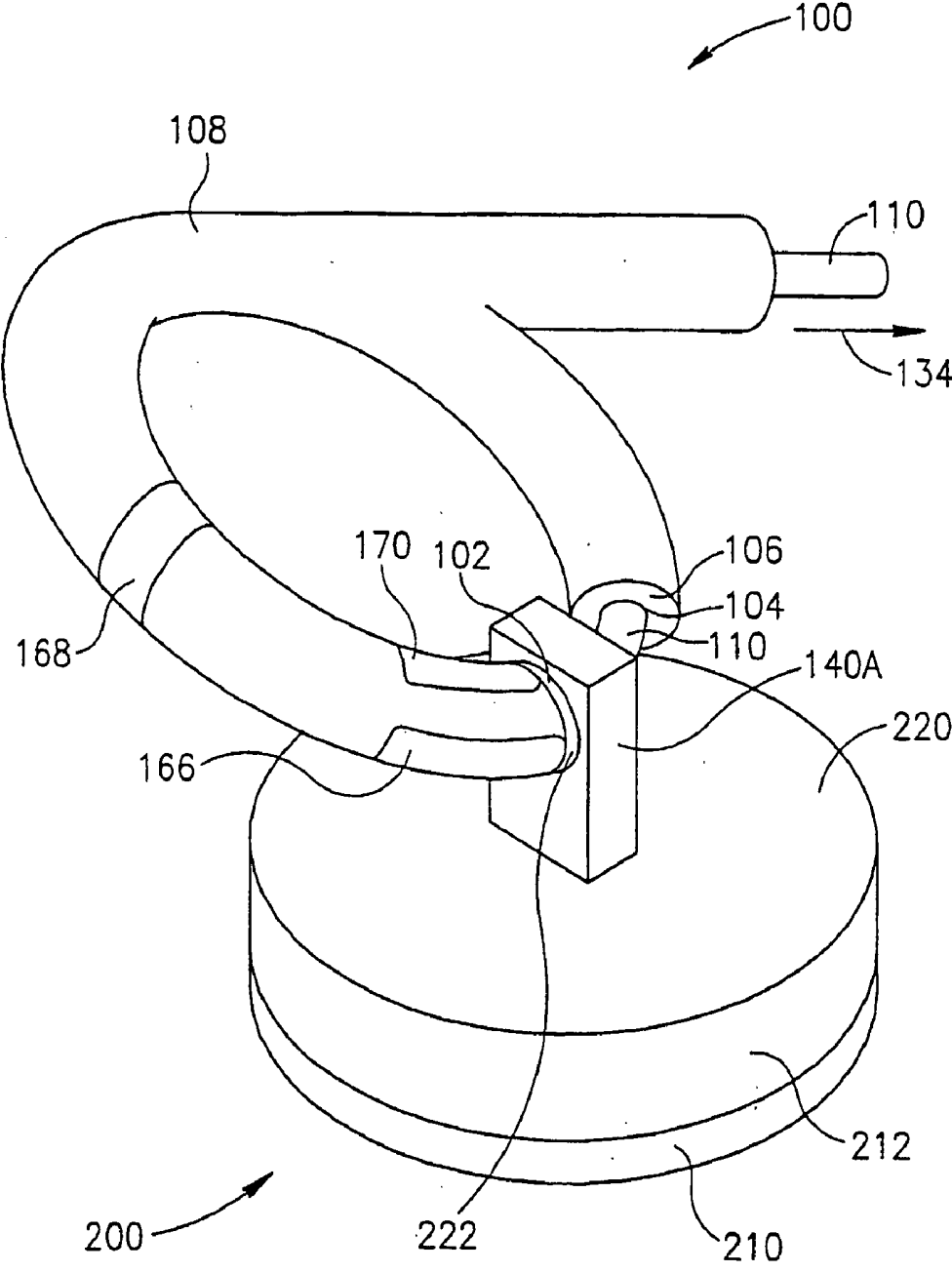

FIG.2

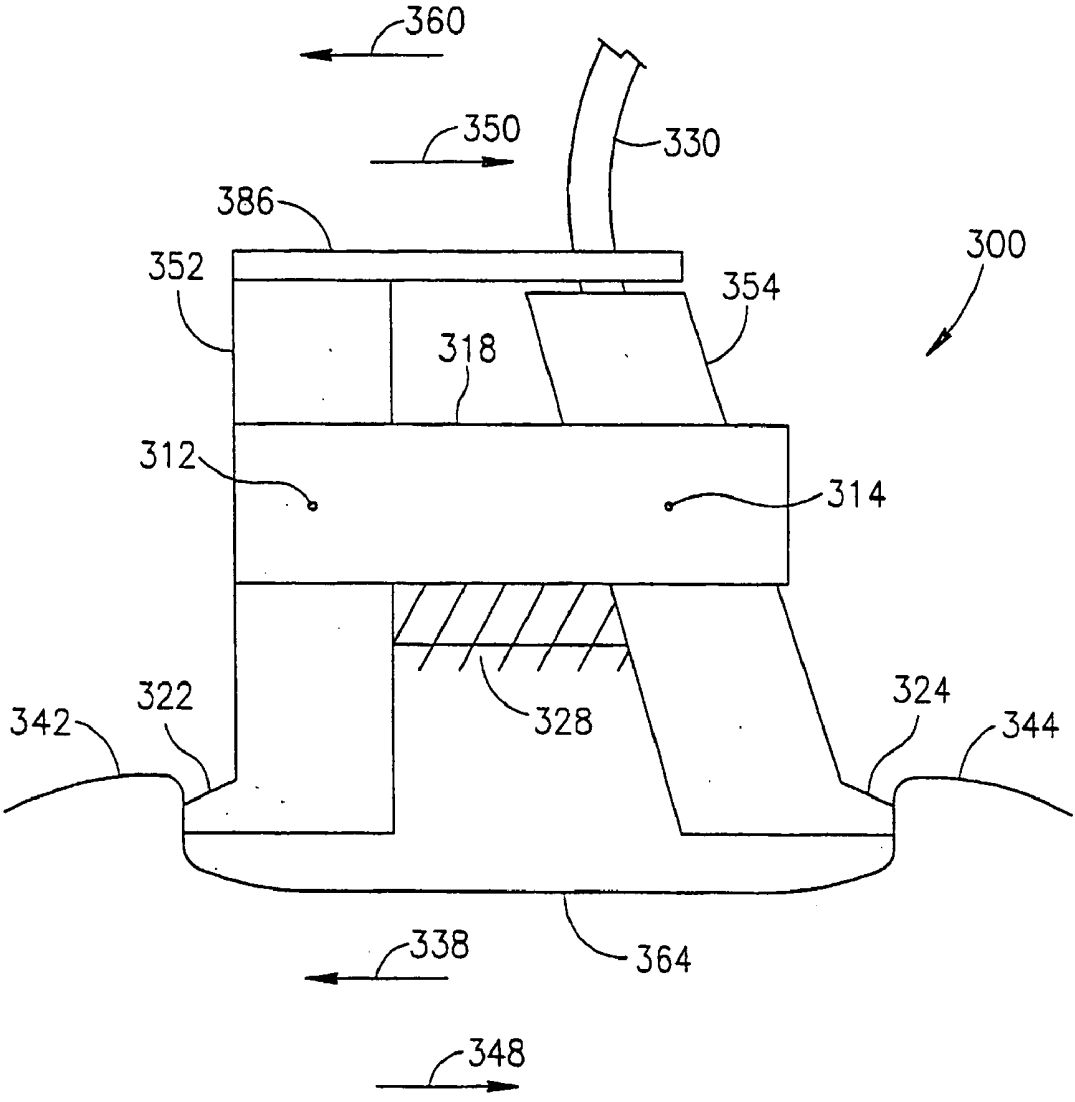

FIG. 3

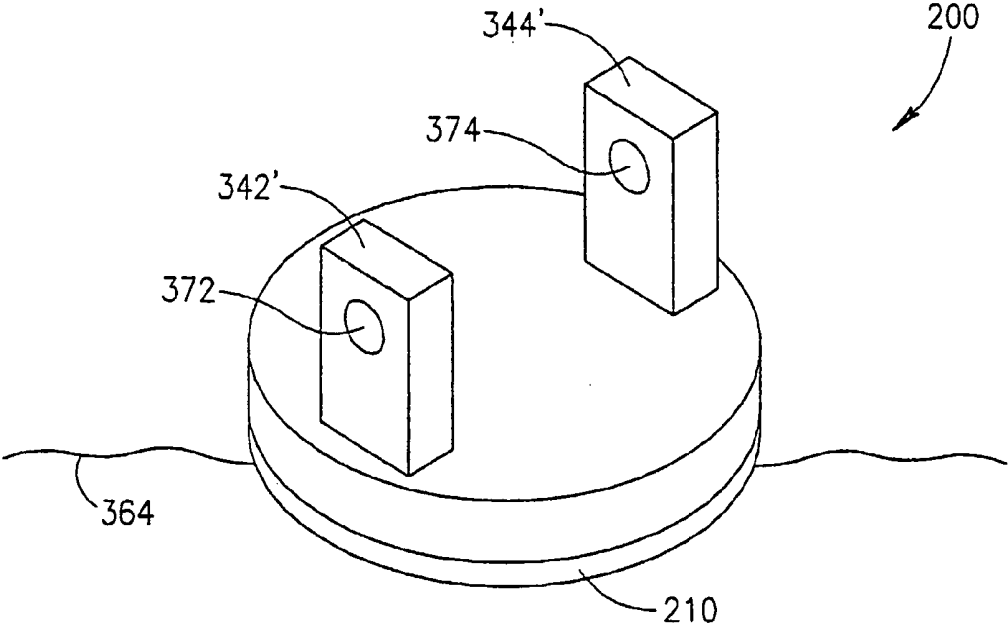

FIG. 4

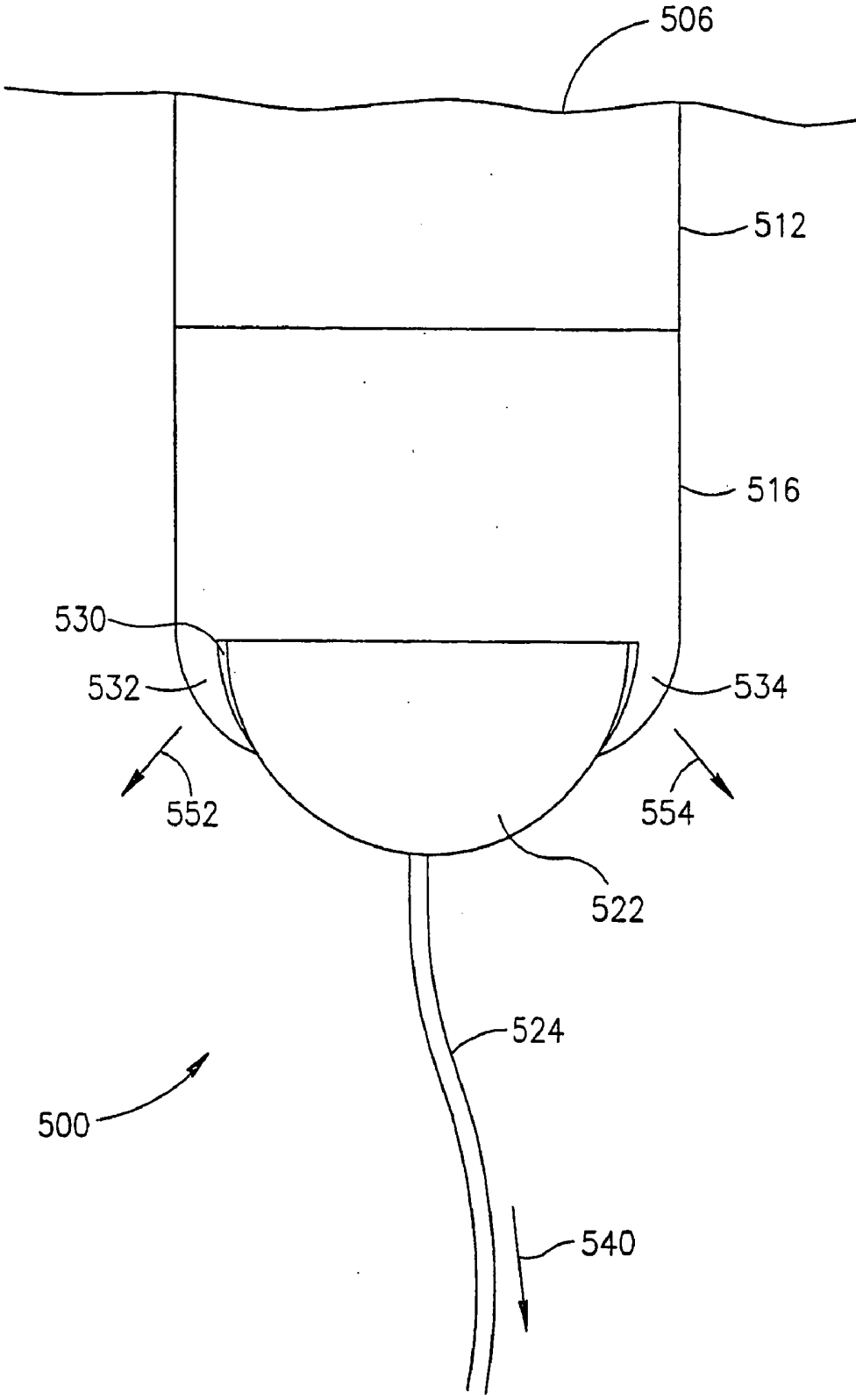

FIG.5

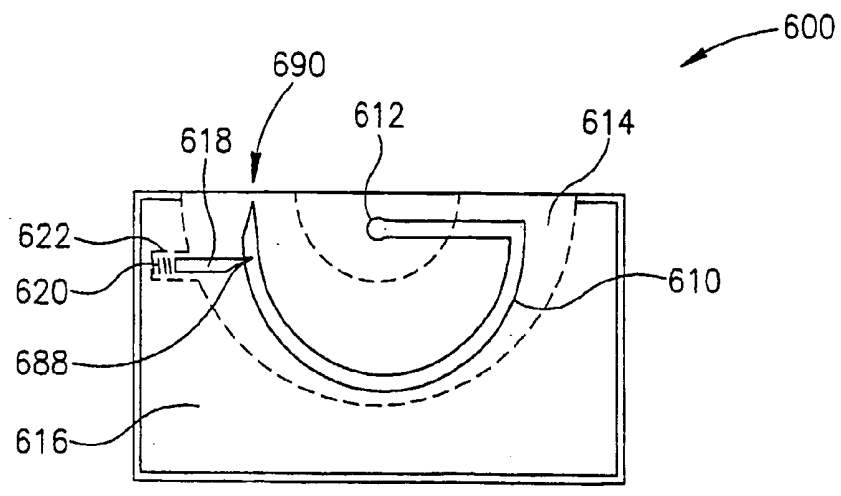

FIG. 6A

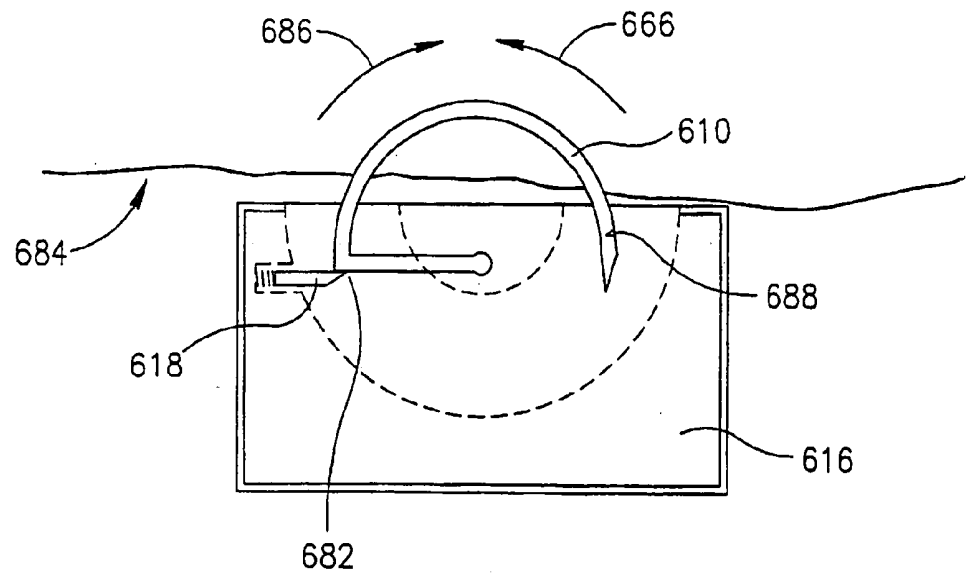

FIG. 6B

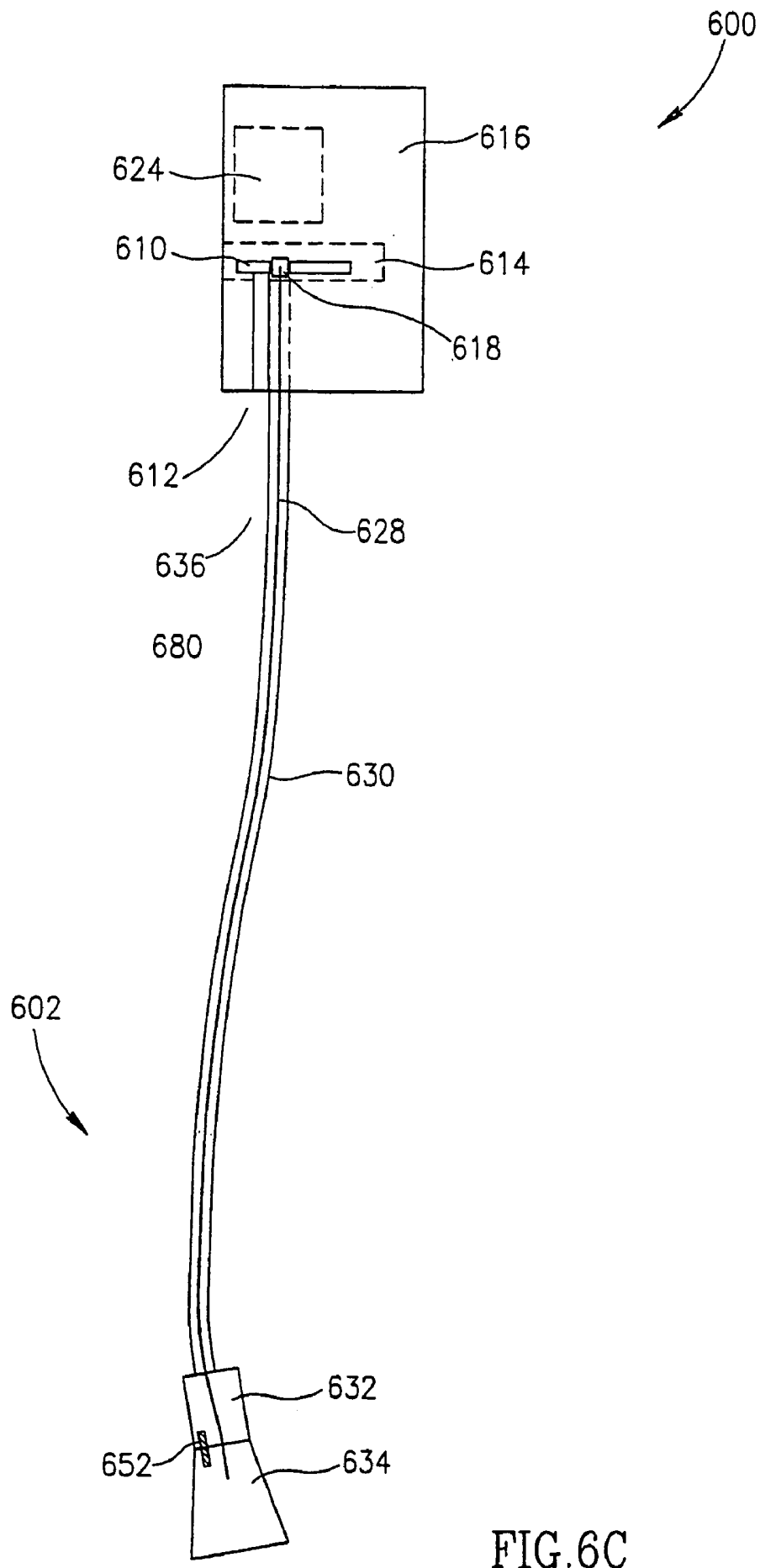

FIG. 6C

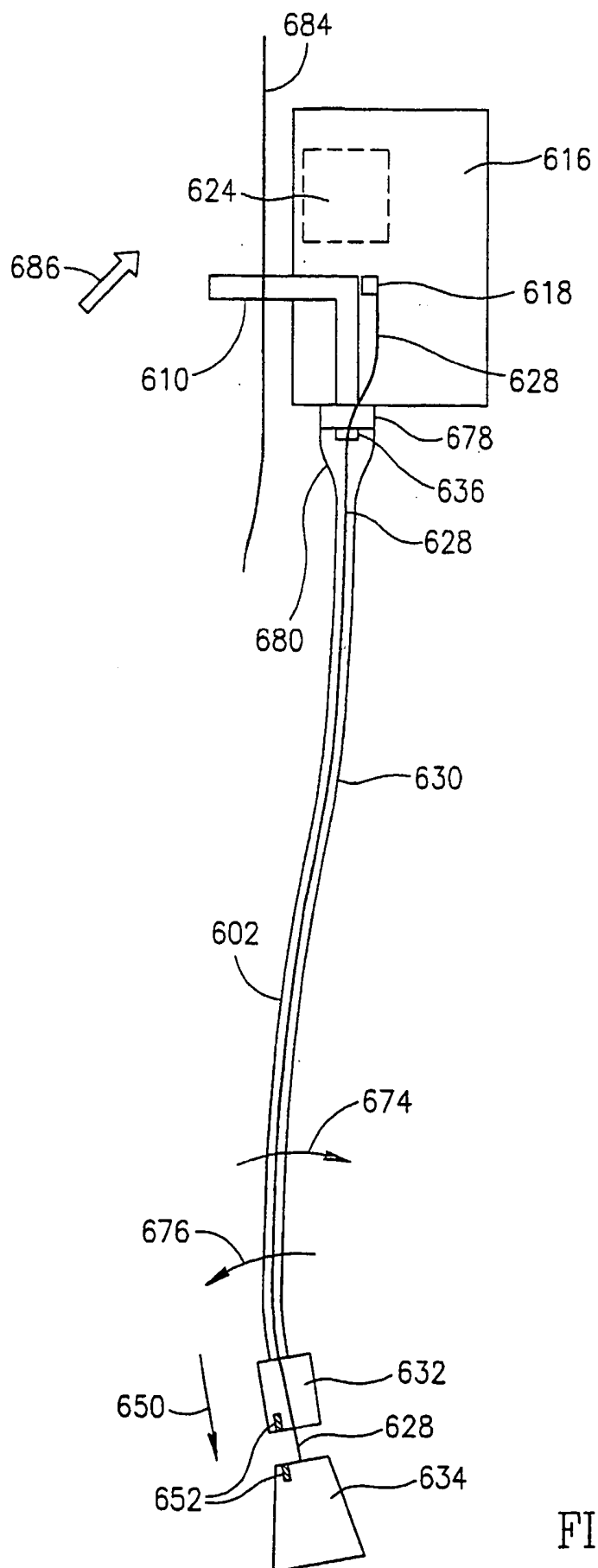

FIG. 6D

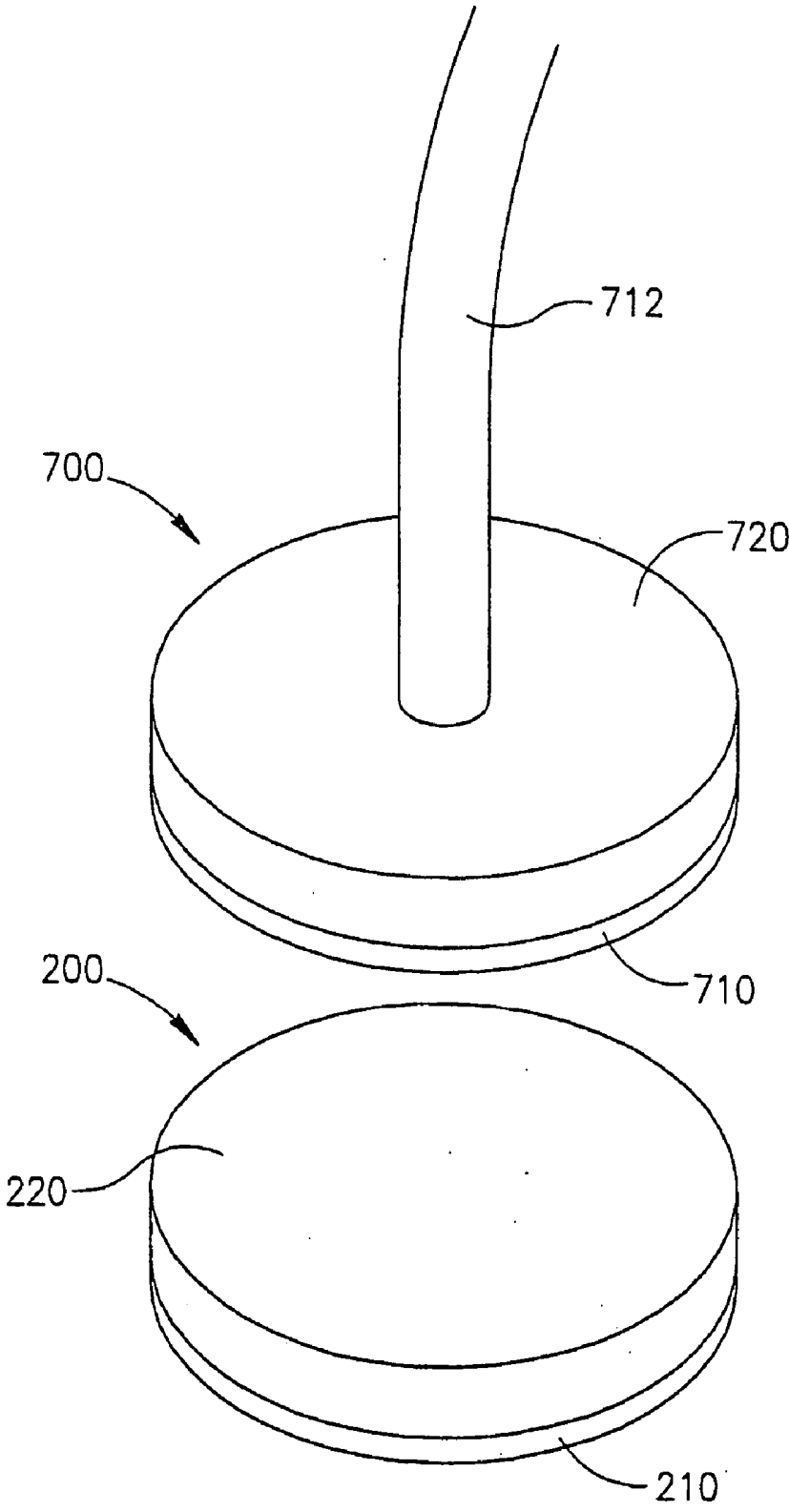

FIG. 7

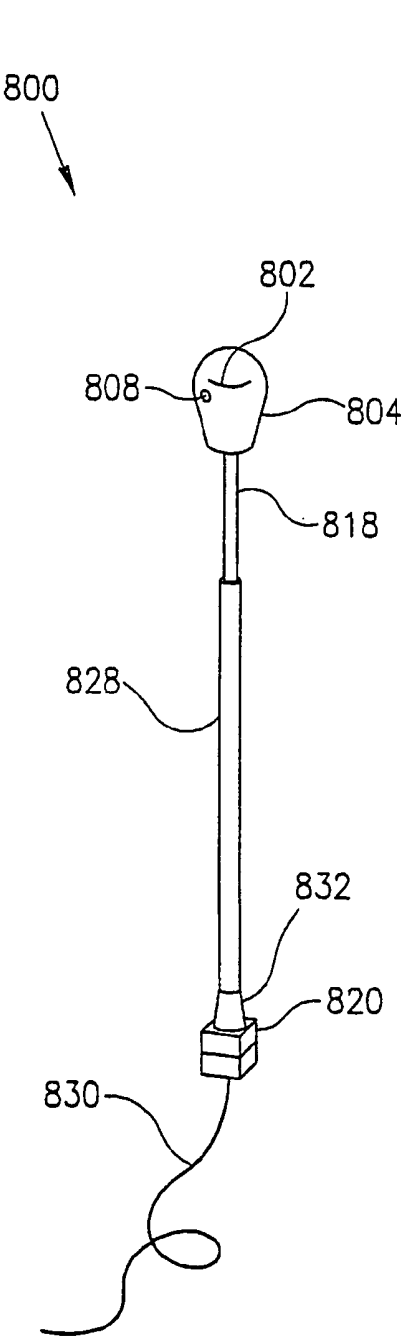

FIG. 8A

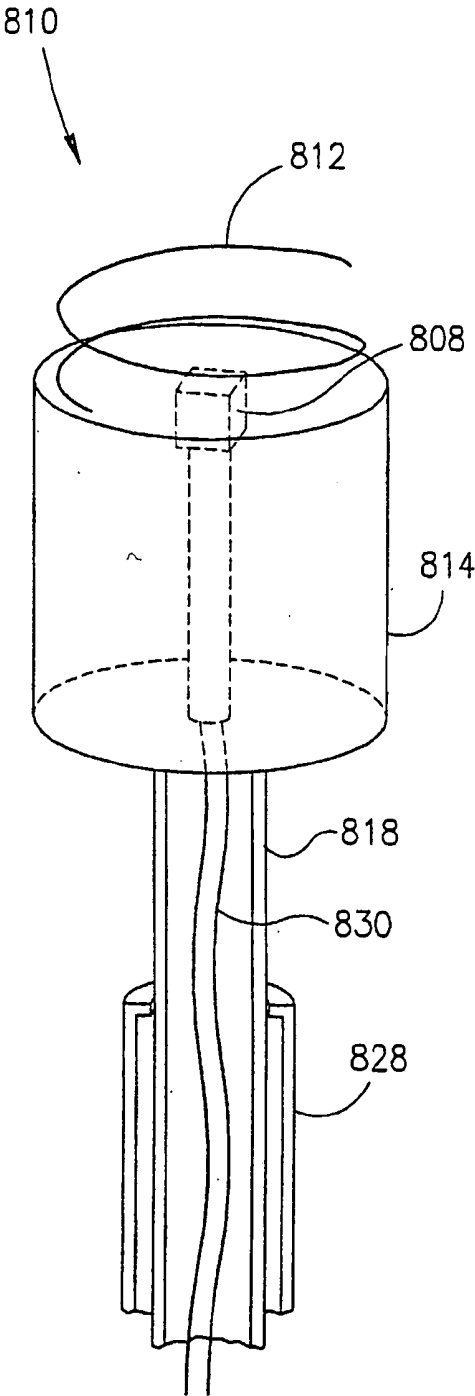

FIG. 8B

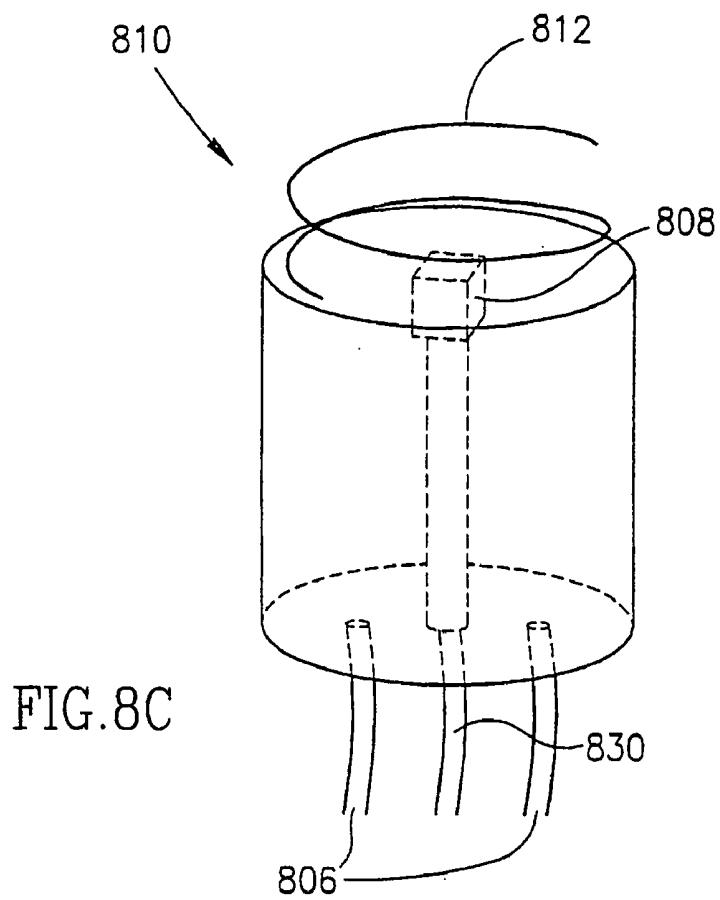

FIG. 8C

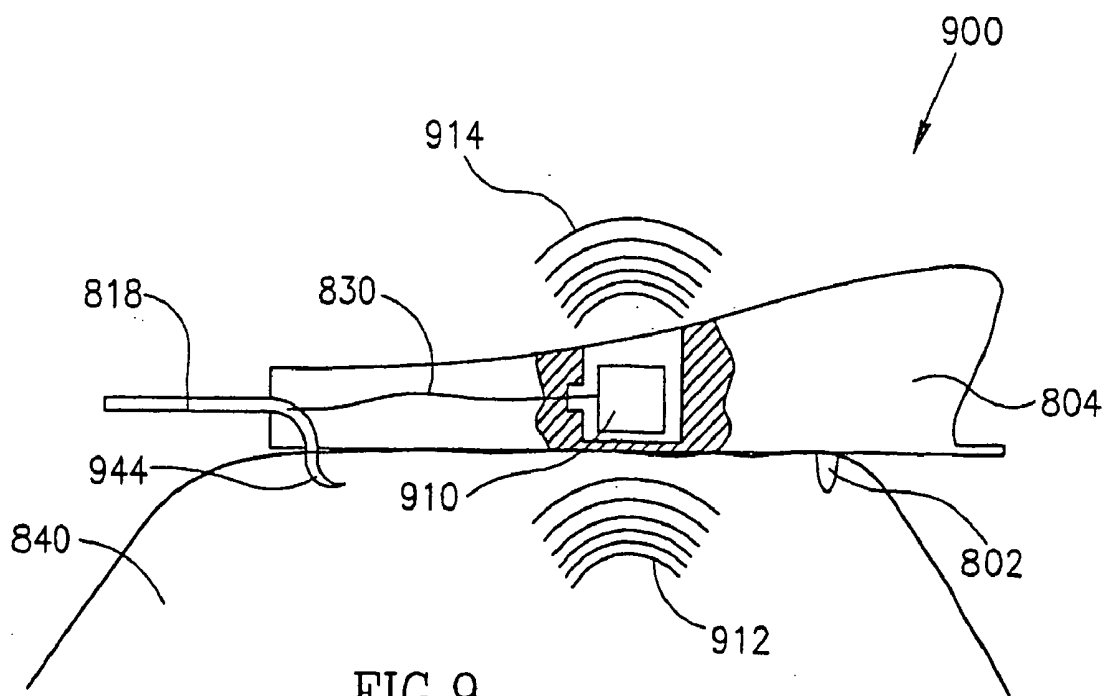

FIG. 9

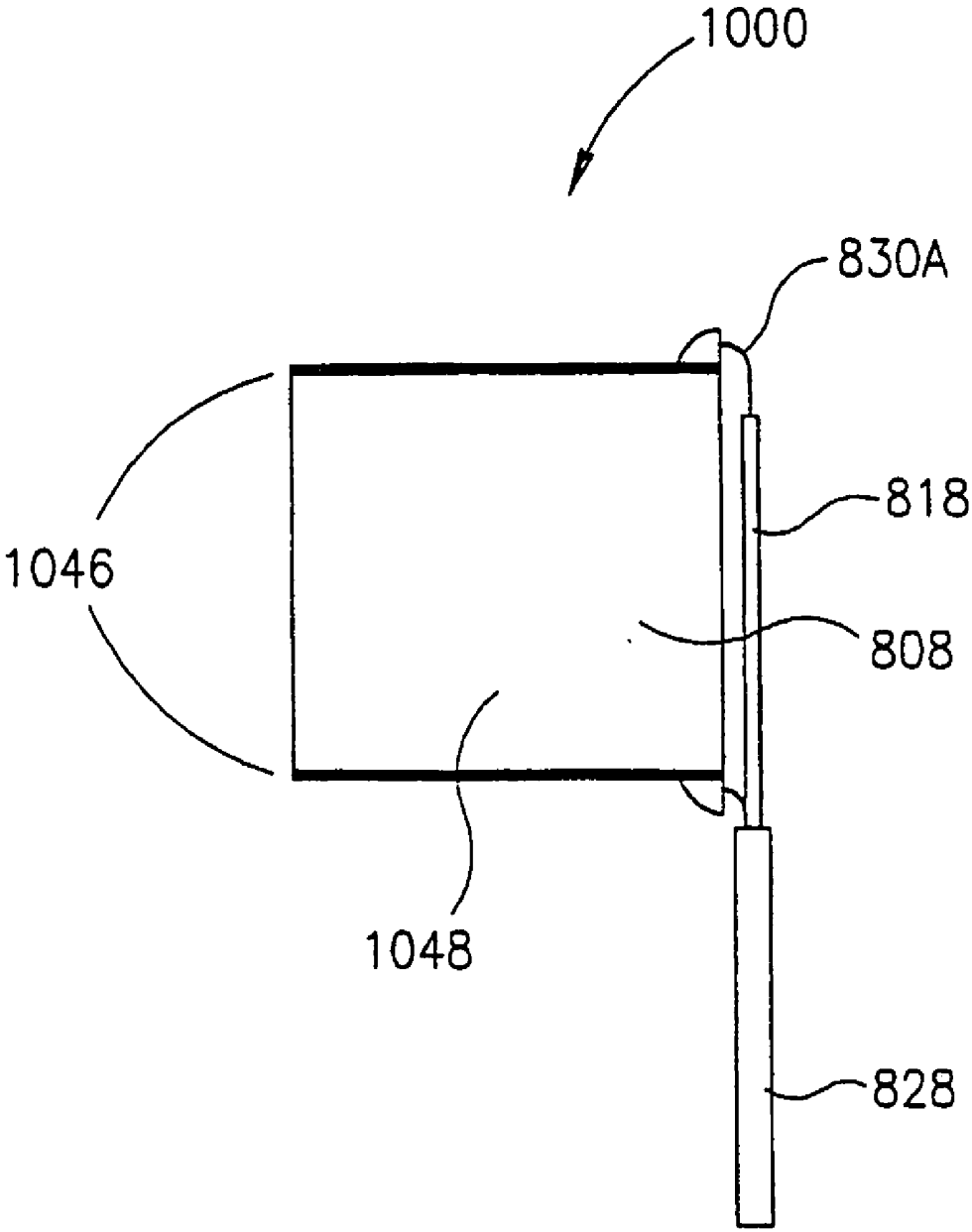

FIG.10

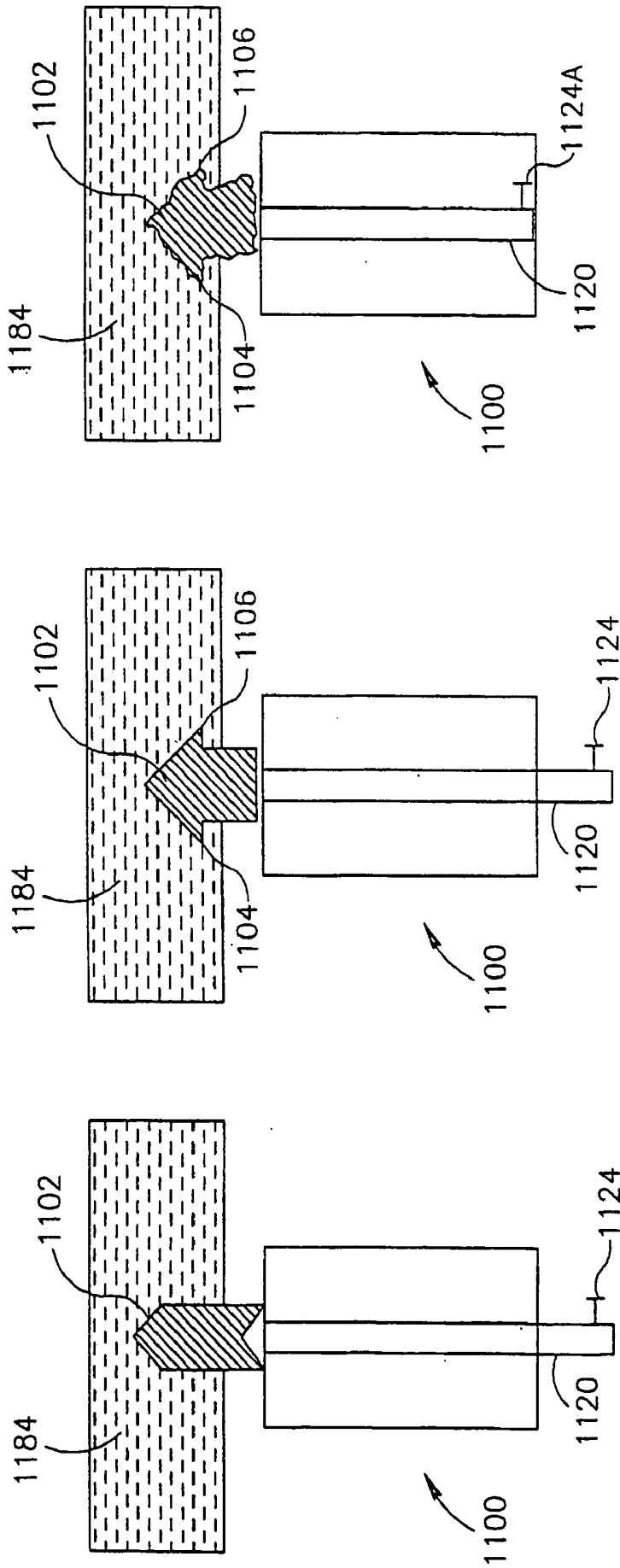

FIG. 11C

FIG. 11B

FIG. 11A

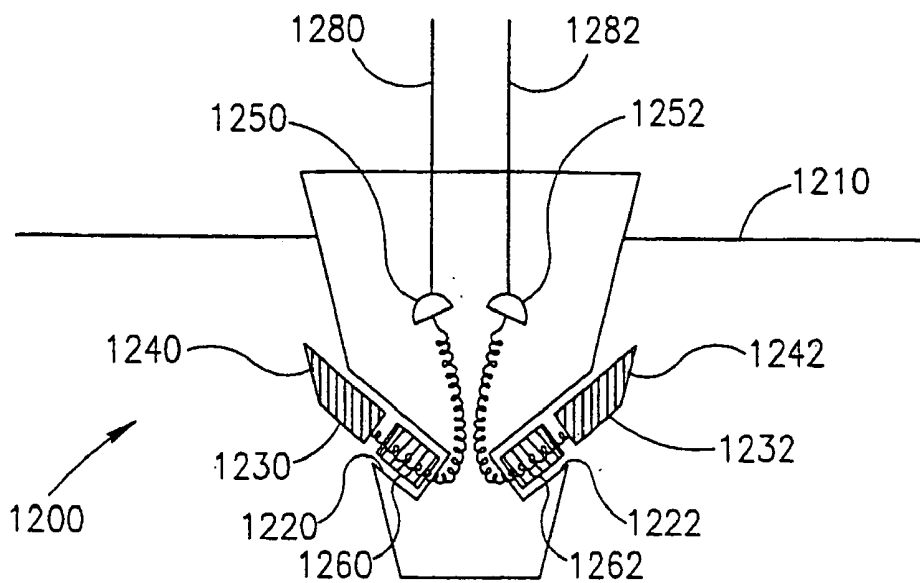

FIG. 12A

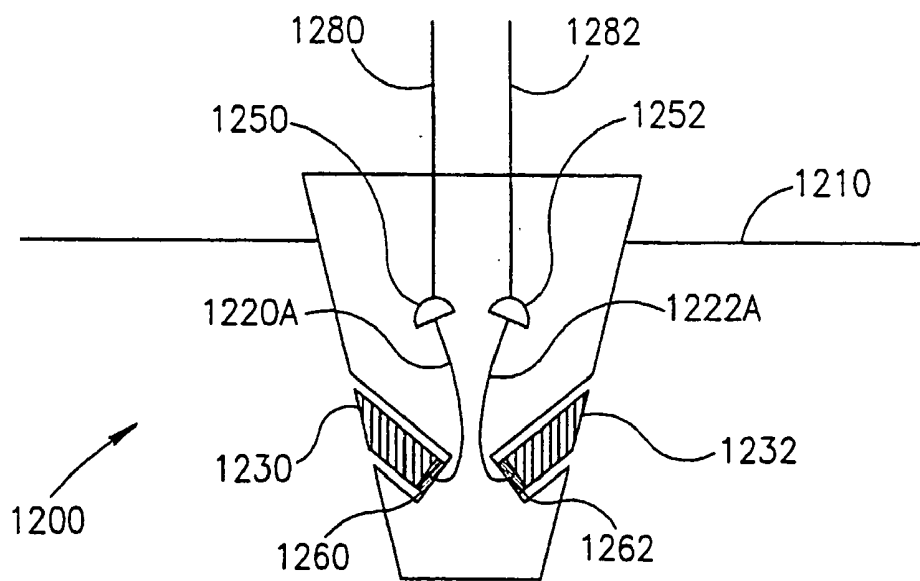
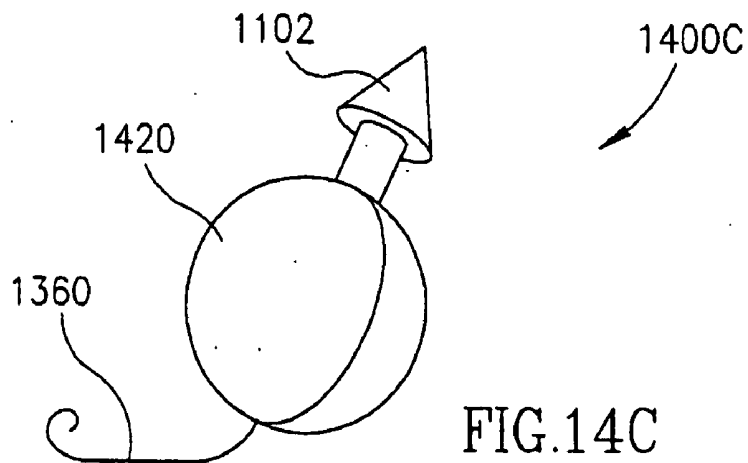
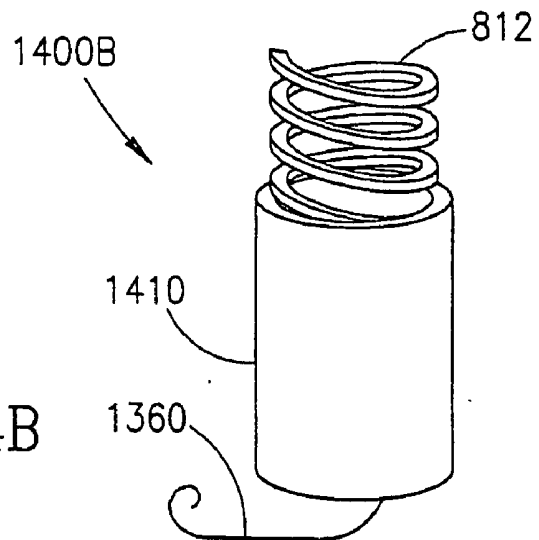
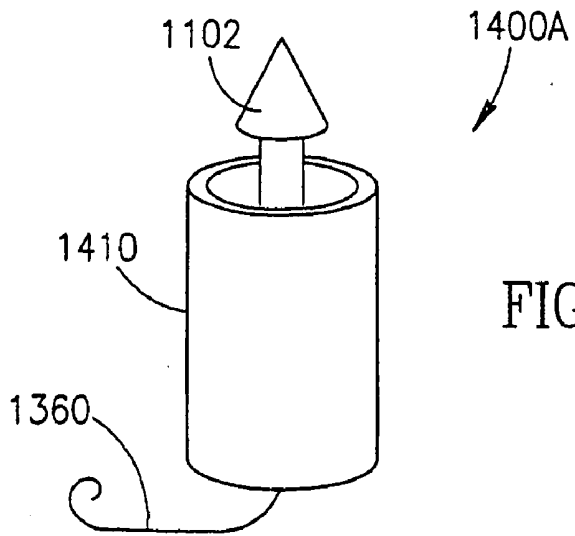

FIG. 12B





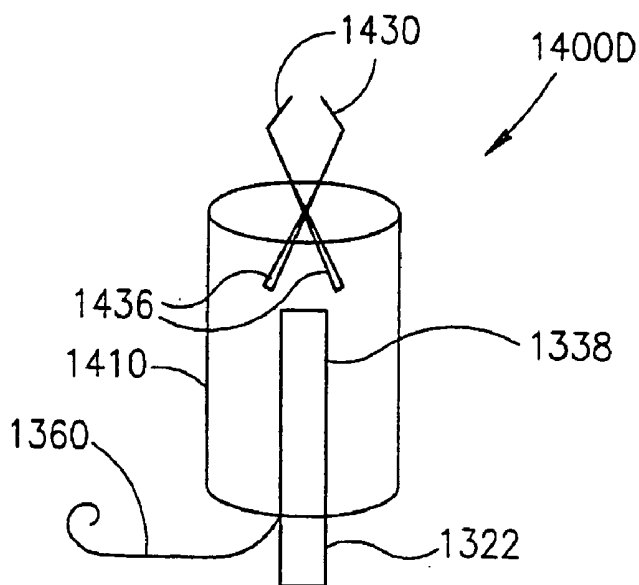

FIG. 14D

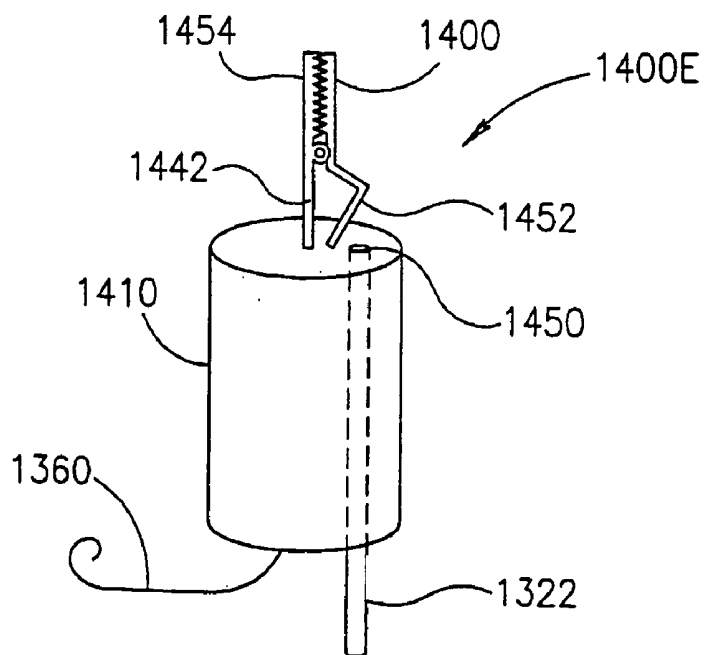

FIG. 14E

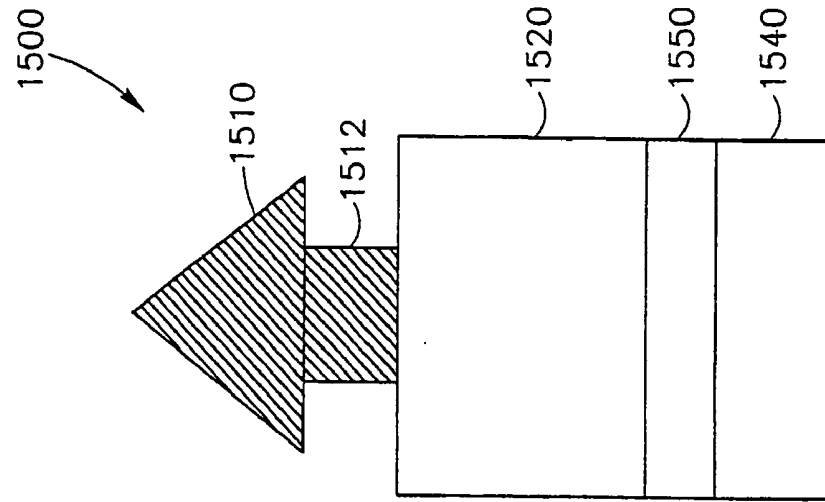

FIG. 15A

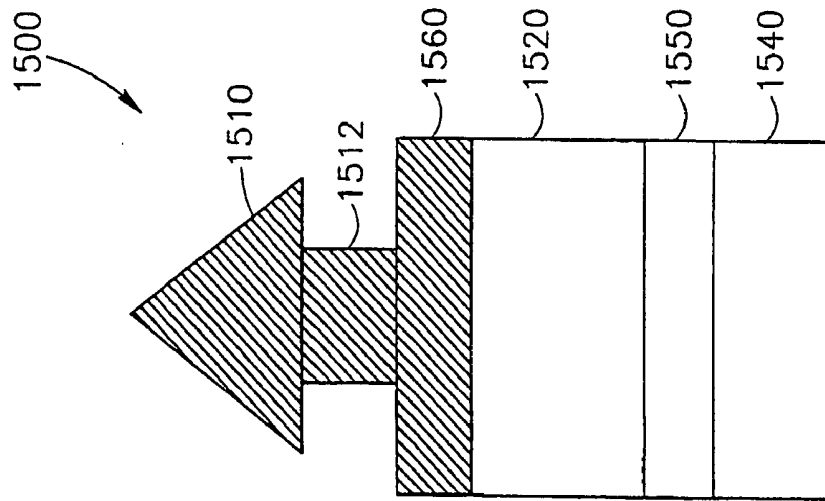

FIG. 15B

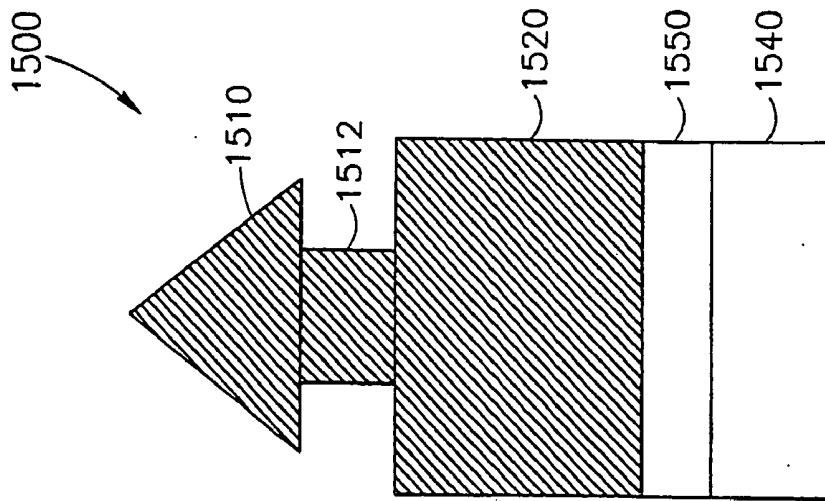

FIG. 15C

## PROBE ANCHOR

### RELATED APPLICATIONS

[0001] This application claims the benefit under 119(e) of the following US provisional applications: serial No. 60/295,569 filed 5 Jun. 2001, serial No. 60/295,573, filed 5 Jun. 2001, serial No. 60/309,783, filed 6 Aug. 2001 and serial No. 60/338,671, filed Dec. 11, 2001. This application is also related to a PCT application filed on even date with this application by applicant in the Israel receiving office and having attorney docket 330/02764, the disclosure of all of these applications is incorporated herein by reference.

### FIELD OF THE INVENTION

[0002] The present invention relates to anchoring a probe to biological tissue.

### BACKGROUND OF THE INVENTION

[0003] Measuring cervical dilation and/or the descent of the fetus in the birth canal, is considered an essential element for properly following the progress of the birth process. When birth canal measurements are made manually, a professional attendant makes, on the average, 10 examinations of the birth canal causing the mother discomfort and/or embarrassment. Additionally, such manual exams are subjective, possibly providing inaccurate information, introducing infection into the birth canal and/or missing key events in between examinations.

[0004] Securing a sterile probe to the tissue adjacent the birth canal, meaning the tissue lining the birth canal, the tissue of the cervix and/or the fetus, for the purpose of monitoring the mother and/or fetus during the birth process, presents difficulties in attaching a probe anchor to the wet, moving tissue adjacent the birth canal. Additionally or alternatively, the probe anchor is routinely subject to strong, sustained movement during birth contractures, jarring during fetal presentation and can be entirely displaced due to birth canal tissue distortion and/or the baby's movement through the birth canal.

[0005] A prior art measurement system, for example, uses V calipers with a strain gauge between its arms that spans the cervix and substantially blocks other monitoring and/or treatment services. Another prior art measurement system, for example, uses a multi-switch membrane that is inserted between the fetus and uterine wall. The placement of this membrane is technically difficult, creates obstruction of the birth area and is uncomfortable for the mother.

[0006] Probe anchors that are implanted in the tissue of the birth canal, for example clamps and/or sutures, may cause discomfort as the tissue of the cervix and/or birth canal expands during the birth process and squeezes and/or strains against the probe anchor. In addition, an implanted probe may cause harm to the fetus, for example if it protrudes significantly into the path of the fetal descent through the birth canal, or if it includes a sharp spike that can otherwise interact with the fetus or other birth canal adjacent tissue. Following the birth process, the implanted probe may be difficult to remove from the birth canal and/or cause harm to the mother. One possible cause for difficulty is that the birth canal tissues following birth are typically thinned, stressed and/or dilated.

[0007] Eibling in U.S. Pat. No. 5,284,141, Kemper et al. in U.S. Pat. No. 5,438,996, Bullard et al. in U.S. Pat. No. 5,851,188, Pettit et al. in U.S. Pat. No. 5,671,736, Sinanan et al. in U.S. Pat. No. 6,173,715 B1 and Urion et al. in U.S. Pat. No. 5,680,859, demonstrate a monitor probe with a barb that enters the skin through a single point to attach monitor wires to biological tissue that is easily dislodged from the tissue.

[0008] Levinson et al. in U.S. Pat. No. 5,727,547, demonstrate a fetal oximeter sensor that is secured in place using suture, possibly posing difficulties during installation.

[0009] Sliwa et al. in U.S. Pat. No. 6,039,701 and WO 98/09565, Zartman in U.S. Pat. No. 4,677,967, Meathrel et al. in U.S. Pat. No. 5,833,622 and Jerath in U.S. Pat. No. 5,222,485, define monitor probes that block a large area of the birth canal, possibly requiring removal to allow presentation of the fetus during the birth process.

[0010] Sherman et al. in U.S. Pat. No. 5,713,371 demonstrate a long spring-loaded jaw incorporating an ultrasound transmitter that attaches to tissue that may obstruct the birth canal.

[0011] Anderson et al. in U.S. Pat. No. 5,645,062, Ritson et al. in U.S. Pat. No. 5,851,179, Munro et al. in WO 00/46319 and Remon et al. in WO 00/47644, present probes with adhesive material that do not readily remove from the biological tissue following use.

[0012] Grafton et al. in U.S. Pat. No. 5,964,783 demonstrate a biodegradable attachment for attaching material to bone that is unsuitable for use in soft tissue probe attachment.

### SUMMARY OF THE INVENTION

[0013] An aspect of some embodiments of the present invention relates to providing a probe anchor for use during the birth process that readily attaches to and/or removes from tissue of the birth canal by operation of a control extension whose operation is effected external and/or internal to the birth canal. Operation of the control remote from the anchor allows the operator's hands to easily attach and/or remove the probe anchor in the wet, moving tissue associated with the birth process.

[0014] In an exemplary embodiment, a probe extension aids in the remote insertion and/or the removal of an anchor from an anchor area. For example, the extension is attached to the anchor mechanism of the probe and manipulation of the extension causes deployment and/or retraction of an anchor mechanism of the probe. Additionally or alternatively, the extension is a tubular structure whose rotation, for example, causes deployment and/or retraction of an anchor mechanism of the probe.

[0015] In an exemplary embodiment, a probe anchored in tissue adjacent the birth canal has one or more wires that connect said probe to a monitor and provide information on the birth process. In an exemplary embodiment, the probe, wires and/or their attachments provide information on fetal position and/or EKG information and can be placed in position with either left or right hand by a single operator, for example an obstetrician, without assistance from additional personnel. In an exemplary embodiment, the probe, wires and/or their connections are color coded, for example,

for proper positional placement. In an exemplary embodiment, the probe, wires and/or their connections are sufficiently pliant, for example, that they do not present a risk to the mother and/or fetus before, during and/or after the birth process. In an exemplary embodiment, the probe, wires and/or their connections do not prevent the mother from moving in association with the birth process, for example, leaning on the bed and/or walking. Additionally or alternatively, they do not obstruct the birth canal and/or manual examination of the birth canal, during the birth process.

[0016] In an exemplary embodiment, the wires are formed into an antenna that sends, for example radiofrequency signals, to a signal receptor connected to a monitor display. In an exemplary embodiment, passage of the fetus through the birth canal is unhindered by the antenna.

[0017] An aspect of some embodiments of the present invention relates to providing a probe anchor mechanism that secures a probe to and/or through one or more points in a tissue of the mother and/or the fetus during the birth process. In an exemplary embodiment, the anchor and/or its mechanism are operable in a sterile environment and/or are disposable following use. In an exemplary embodiment, the attachment is provided by a curved wire that extends from the probe through the tissue so the tissue is secured along a cord of the wire's curvature. As the cervical tissue expands and/or moves during labor, the tissue pierced by, and thus fastened with the curved wire, moves to a longer cord length position on the curved wire. The greater cord length allows expansion of the fastened tissue without increasing force on the tissue, affording greater comfort to the subject than, for example, a rigid clamping fastener. A rigid clamp, for example a rigid caliper operated by a screw mechanism that fixes the caliper jaw in place, does not expand as the amount of tissue between the jaws increases, resulting in pinching of the expanding tissue, reduction of blood supply within the fastened tissue and possible harm due to apoxia and/or local trauma as the tissue chaffs between the fixed clamp jaws.

[0018] In an exemplary embodiment, the probe anchor has two or more legs with sharp ends facing each other that secure in an anchor area and/or compress the tissue of the anchor area in between the sharp ends. Optionally, the two sharp ends are flexibly attached to the probe to allow for cervical tissue movement and/or expansion during the birth process. In an exemplary embodiment, a probe anchor comprises an expandable anchor that secures to a tissue by expanding within the tissue, for example a tissue adjacent the birth canal and/or other tissue areas in the body.

[0019] An aspect of some embodiments of the present invention relates to providing a probe anchor that secures in and/or against a tissue of the birth canal and/or another body tissue whose anchor mechanism, for example a curved wire or two or more legs with sharp ends, is tensioned towards the open position. In an exemplary embodiment, the curved wire and/or legs with sharp ends are pressed against a tension force, caused for example by a spring mechanism, to anchor in the tissue. Optionally, a pin or other restraining element is provided to prevent the anchor from opening.

[0020] In an exemplary embodiment of the invention, this type of normally open anchor (and other embodiments described below) may be used to provide an anchor in which the implantation technique is decoupled from the removal technique. This decoupling may be exhibited, for example,

by using a different method to attach and to detach the anchor. Alternatively or additionally, the decoupling is exhibited by the force required to open the device not be complementary to the force exerted by the device when it closes. This contrasts, for example, with normally closed anchors which are implanted by releasing the anchor to a closed position but require considerable force to be brought back to an open position. Other methods of providing this potential advantage are, for example, an anchor which is inserted easily and (possibly) after a while, deforms or otherwise changes so that it is also relatively easy to remove. In some embodiments of the invention described below, the easy removal is timed and/or designed to allow the anchor to stay attached during the monitoring of part or all of a birth process.

[0021] In an exemplary embodiment, a probe anchor readily removes from attachment to the birth canal and/or fetus at any stage of the birth process only by action of an operator and without intrusion of the operator's hands in the birth canal. Optionally, the anchor mechanism is maintained in the closed position with a retainer mechanism. Disengaging the retainer mechanism, for example following labor, allows the anchor mechanism to open so the probe is readily removed from the tissue. The open anchor mechanism adds a safety feature in that the retracted sharp end will not damage tissue during attachment and/or removal from the birth canal.

[0022] In an exemplary embodiment, when the anchor is implanted it is tensioned towards a closed position. Once deployed, it changes to a normally open position, for example at once, after a time period and/or due to the application of a causative effect, such as force or heat.

[0023] In an exemplary embodiment, a control which allows the anchor to open and/or close is located distant from the anchor area so that removal of the probe is optionally affected without necessitating placing the operator's hands in the cervix.

[0024] An aspect of some embodiments of the present invention relates to providing a probe with an anchor attachment for attachment to a body tissue, for example, the birth canal, heart and/or intestines, whose configuration and/or surface geometry on removal is altered in respect to its configuration and/or surface geometry during placement in the birth canal. For example a curved wire and/or two or more legs with sharp ends and/or an expandable anchor deforms and/or weakens over a period of time, for example due to a chemical reaction and/or interaction with the surrounding tissue.

[0025] In an exemplary embodiment, the probe, its connection to the probe anchor and/or the anchor itself, deforms and/or weakens, for example over several hours to several days due to, for example hydrolysis, so that with time the probe anchor becomes easier to remove and/or falls away from the anchor area. Additionally or alternatively, the probe, its connection to the probe anchor and/or the anchor itself, comprise a material that deforms due to increases in temperature and/or reverts to its original form when the original temperature returns. In an exemplary embodiment, an anchor probe comprises shape memory polymers that change shape in response to a temperature increase as identified by Steven Ashley in "Shape Shifters", *Scientific American*, May 2001.

[0026] An aspect of some embodiments of the invention relates to a two part soft tissue anchor, in which one part anchors directly to the soft tissue and a second part attaches to the first part. In an exemplary embodiment of the invention, the attachment method allows removing the second part from the anchored part. The anchoring may be of various kinds, for example adhesive or mechanical (e.g., at least one spike, a barb and/or a hook).

[0027] Optionally, if the anchoring is at a wrong location (or if removal is desired for other reasons), the second part is removed and then, optionally, a new anchoring is made at a new location. The old anchoring may fall out by itself (e.g., using various mechanism as described herein) or it may be removed manually, for example at a more convenient time. Optionally a safety tether is attached to the anchoring section, to prevent undesired migration and/or to assist removal.

[0028] An aspect of some embodiments of the present invention relates to providing a probe anchor that secures to an anchor area, for example in the birth canal or another tissue of the body, with an bioadhesive layer. In an exemplary embodiment the bioadhesive layer attaches to an area equal to or greater than 1 square centimeter so that forces from tissue movement, for example related to movement associated with the birth process, are spread over the attachment area to prevent premature detachment of the probe from the anchor area.

[0029] In an exemplary embodiment the bioadhesive layer and/or the probe anchor biodegrade and/or weaken after a base period, for example three, six, eight, twelve, eighteen and/or twenty-four hours or a period that encompasses a typical birth process or a part thereof, for example 48 hours. Following the base period, the bioadhesive layer and/or probe anchor weaken so they remove with decreasing force, such as by the pulling of the probe by an operator, or possibly they fall out by themselves. Alternatively or additionally, the time is shorter, for example 10, 20, 30 or 60 minutes or a different time suitable for a procedure, such as monitoring a small number of contractions.

[0030] In an exemplary embodiment, a probe anchor has a tissue bioadhesive surface that is adapted to adhere to the cervical and/or fetal tissue and a probe receiver surface adapted to receive one or more of a variety of probe attachments, for example that monitor the mother and/or fetus during childbirth. In an exemplary embodiment, the probe receiver surface is adapted to receive a probe with a bioadhesive layer. Additionally or alternatively, the probe receiver surface is adapted to receive a probe, for example, with a curved wire attachment end and/or a probe with two or more legs with sharp ends.

[0031] In an exemplary embodiment, the probe anchor and/or its tissue bioadhesive surface deform, weaken and/or dissolve in response to an externally applied agent, for example a catalytic agent and/or electromagnetic waves, such as heat, ultrasound and/or electricity.

[0032] Following the birth process, the electromagnetic waves and/or catalytic agent are applied so the probe, probe anchor and/or probe attachment can be easily removed from the birth canal.

[0033] An aspect of some embodiments of the present invention relates to providing a probe with an expandable

anchor to attach it to a tissue area. In an exemplary embodiment, fluid, for example contained in an internal reservoir, is released to effect expansion of the anchor once it is positioned in an anchor area. Additionally or alternatively, deflation of the expandable anchor is accomplished by releasing the fluid from within the anchor, for example, using an appropriate instrument that punctures the probe. Additionally or alternatively, the expandable anchor gradually deforms following a base period, so that it loses its securing aspects to the anchor area. Additionally or alternatively, the expandable anchor gradually dissolves following a base period and loses its fluid, deflates and removes from the anchor area and/or completely dissolves.

[0034] An aspect of some embodiments of the present invention relates to providing a probe anchor deployer apparatus that aids in deployment and/or placement of the probe anchor in, for example tissue of the os cervix and/or the tissue of the birth canal and easily separates from said probe following deployment. In an exemplary embodiment, one or more probe anchors are contained in a sterile cartridge that fits into the deployer apparatus. Additionally or alternatively, one or more probe anchors fit into a deployment compartment on the deployer apparatus without a cartridge. Optionally, the deployer apparatus cartridge and/or anchor, are fully sterile during use in the birth canal. Additionally or alternatively, the parts of the deployer apparatus cartridge and/or anchor, for example, that come into contact with the tissue of the birth canal area, are sterile. In an exemplary embodiment, the deployer apparatus installs a probe anchor into a tissue of the birth canal in a single action, causing deployment of the probe anchor and/or separates from said anchor and/or does not require further manual inspection.

[0035] In an exemplary embodiment of the invention, the deployer includes an anchoring activation mechanism that activates a corresponding anchoring mechanism of the probe. Alternatively or additionally, the deployer includes a release activator that can activate a release mechanism of the anchor, to assist in removal thereof from the cervix.

[0036] There is thus provided in accordance with an exemplary embodiment of the invention, a probe anchor that attaches a probe to a tissue adjacent a birth canal, comprising:

[0037] (a) a soft tissue anchor including a release mechanism;

[0038] (b) a cable sufficiently pliable that it will not harm a fetus during passage through the birth canal coupled at one end thereof to said release mechanism; and

[0039] (c) a control coupled to an opposite end of said cable and operative to remotely release said release mechanism using said cable without requiring manual stabilization directly to said anchor. Optionally, said release mechanism is mechanically operated. Alternatively or additionally, said release mechanism is electrically operated.

[0040] In an exemplary embodiment of the invention, said release mechanism stores a releasing energy and whereby said control releases said energy. Alternatively or additionally, the anchor comprises an energy retainer that prevents activation of said releasing energy until its release by said control.

[0041] In an exemplary embodiment of the invention, said probe anchor comprises two sections:

[0042] (a) an anchor section that connects to said tissue and is adapted for the attachment of a probe section; and

[0043] (b) a probe section that attaches to said anchor section.

[0044] Optionally, said anchor section defines a volume suitable for receiving said probe section. Optionally, said probe section fits in said volume and is removably coupled to said volume. Alternatively or additionally, said volume comprises one or more resilient projections that restrain said probe section from exiting said volume. Optionally, said resilient projections release said probe section from said volume upon application of a probe-displacing force.

[0045] In an exemplary embodiment of the invention, said anchor section weakens over time, facilitating its removal from said tissue. Optionally, said anchor section partially dissolves over time. Alternatively or additionally, said anchor section completely dissolves over time. Alternatively or additionally, said anchor section deforms over time. Optionally, said deformation occurs in response to a temperature change.

[0046] In an exemplary embodiment of the invention, pulling said cable away from said anchor activates said mechanical release mechanism. Alternatively or additionally, rotating said cable around its axis in relation to said anchor activates said mechanical release mechanism.

[0047] In an exemplary embodiment of the invention, said probe comprises a sensor that monitors said tissue. Optionally, said sensor comprises an ultrasound transducer ultrasonically coupled to said anchor section and ultrasonically coupled by said anchor section to said tissue.

[0048] In an exemplary embodiment of the invention, said cable comprises a conducting wire. Optionally, said conducting wire carries signal data. Alternatively or additionally, said conducting wire is visually coded to indicate function or placement of said conducting wire. Alternatively or additionally, said conducting wire is connected to an antenna that transmits signal data. Optionally, said probe comprises an electromagnetic RF transmitter coupled to said antenna.

[0049] In an exemplary embodiment of the invention, said anchor section is visually coded to indicate function or placement of said anchor section.

[0050] In an exemplary embodiment of the invention, said anchor section is configured so it does not obstruct the birth canal during a birth process. Alternatively or additionally, said anchor section is configured so it does not obstruct manual examination of the birth canal.

[0051] There is also provided in accordance with an exemplary embodiment of the invention, a probe anchor that attaches a probe to soft tissue adjacent a birth canal, comprising:

[0052] (a) an anchor that has a closed position and an open position;

[0053] (b) a tension element that urges said anchor toward said open position;

[0054] (c) a closure control operative to maintain said anchor in said closed position.

[0055] Optionally, said anchor comprises a wire passed through said tissue when said anchor is in the closed position. Alternatively or additionally, said anchor comprises one or more legs with sharp ends pressed into said tissue when said anchor is in the closed position. Alternatively or additionally, release of said closure control, allowing said anchor to return to the open position, is activated by an extension remote from said anchor.

[0056] In an exemplary embodiment of the invention, the anchor comprises a tensioning element urging said anchor to be in said closed position.

[0057] In an exemplary embodiment of the invention, said anchor is adapted to change from a normal closed to a normally open configuration following attachment of said probe to soft tissue.

[0058] In an exemplary embodiment of the invention, said tension element comprises a shape memory polymer. Optionally, said shape memory polymer is coupled to a delaying mechanism that delays said opening of said anchor. Optionally, said delaying mechanism comprises a material that biodegrades over a period of time during which period it prevents said a shape memory polymer from drawing said anchor into the open position. Alternatively or additionally, said delaying mechanism comprises a material that dissolves in response to an external causative factor.

[0059] There is also provided in accordance with an exemplary embodiment of the invention, a probe that anchors in soft tissue adjacent a birth canal, comprising:

[0060] a probe defining one or more lumens;

[0061] a spike element set in each of said one or more lumens with a front end extending out of said lumen; and

[0062] a deforming element that deforms in response to temperature increase above a base temperature, connecting said spike to said lumen;

[0063] wherein deformation of said deforming element causes said front end of said spike to retract into said lumen. Optionally, said lumen includes a delay plug that prevents retraction of said spike element. Optionally, said delay plug comprises a material that weakens over a period of time. Alternatively or additionally, said delay prevents retraction of said one or more spike elements for a minimum of eight hours. Alternatively or additionally, said delay plug comprises a biodegradable material. Alternatively or additionally, said delay plug comprises a material that degrades in response to an external causative factor. Optionally, said external causative factor comprises a compound. Alternatively or additionally, said external causative factor comprises electromagnetic waves.

[0064] There is also provided in accordance with an exemplary embodiment of the invention, an expanding probe anchor that attaches a probe to soft tissue adjacent a birth canal, comprising:

[0065] a probe with an expandable anchor member adapted to be inserted into said soft tissue;

- [0066] a fluid reservoir containing a fluid, external to said canal and connected to said expandable anchor by a fluid conduit; and
- [0067] a valve between said reservoir and said anchor that maintains said fluid in said anchor following its flow into said anchor from said reservoir. Optionally, said fluid reservoir is flexible and compression of said reservoir causes said fluid to move through said conduit into said anchor member. Alternatively or additionally, movement of said fluid into said anchor member causes expansion of said anchor member. Alternatively or additionally, said anchor member weakens over time and maintains said fluid for a base period of time following which it releases said fluid. Optionally, said release occurs following a minimum of eight hours. Alternatively or additionally, said anchor member comprises a material that releases said fluid in response to an external causative factor. Alternatively or additionally, said anchor member comprises a material that releases said fluid in response to a natural biological material contained in said canal.
- [0068] There is also provided in accordance with an exemplary embodiment of the invention, a probe anchor deployment apparatus that attaches a probe anchor to soft tissue adjacent a birth canal, comprising:
- [0069] (a) an anchor deployment apparatus with a grasping end that grasps a probe;
- [0070] (b) a probe with an anchor mechanism suitable for attachment to said tissue;
- [0071] (c) a handle extension extending from said grasping end out of said birth canal; and
- [0072] (d) a deployment mechanism along said handle extension that deploys said anchor mechanism. Optionally, said apparatus is adapted to carry two or more probes. Alternatively or additionally, said apparatus is adapted to carry two or more probes in a magazine. Optionally, a second probe moves into said grasping end following deployment of a first probe.
- [0073] In an exemplary embodiment of the invention, said anchor includes a release mechanism and wherein said apparatus is adapted to activate said release mechanism.
- [0074] There is also provided in accordance with an exemplary embodiment of the invention, an adhesive probe anchor, comprising:
- [0075] an adhesive on said probe that adheres to a mucosal surface adjacent a birth canal with sufficient adherence to resist detachment due to forces generated by the birth process for a base period of time; and
- [0076] a sensor removably connected to said probe. Optionally, said base period comprises a minimum of eight hours. Optionally, said adhesive weakens in response to biological compounds naturally contained within said canal. Alternatively or additionally, said adhesive weakens in response to an external causative factor. Alternatively or additionally, said connection between said sensor and said probe is a mechanical connection. Alternatively or additionally, said connection between said sensor and said probe is a biodegradable connection that weakens over a base period of time during which it resists detachment due to forces generated by the birth process. Optionally, said wherein said base period comprises a minimum of eight hours. Alternatively or additionally, said weakening occurs in response to biological compounds naturally contained within said canal. Alternatively or additionally, said biodegradable connection weakens in response to an external causative factor.
- [0077] There is also provided in accordance with an exemplary embodiment of the invention, a method for securing an anchor, having a base and a curved wire having a point, to the cervix, comprising:
- [0078] (a) positioning said anchor at a tissue of the cervix such that said base contacts the cervix;
- [0079] (b) transfixing said cervix with said curved wire, point first, so that said point is covered by said base when said transfixing is completed. Optionally, said probe anchor comprises an ultrasound transducer ultrasonically coupled to said anchor and attaching comprises attaching said ultrasonically coupled transducer to said cervix.
- [0080] There is also provided in accordance with an exemplary embodiment of the invention, a method for adhering a probe with a sensor to soft tissue adjacent a birth canal and monitoring fetal passage, comprising:
- [0081] grasping a probe apparatus, including a sensor and an adherent surface that weakens over time;
- [0082] pressing said adherent surface onto said soft tissue;
- [0083] monitoring fetal passage through said canal with said sensor; and
- [0084] confirming the removal of said adherent surface from said soft tissue following its weakening below its adherence threshold. Optionally, said confirming occurs following a minimum of eight hours of adherence. Alternatively or additionally, said weakening occurs in response to biological compounds naturally contained within said canal. Alternatively or additionally, said weakening occurs in response to an external causative factor. Alternatively or additionally, the method comprises removing said sensor from said soft tissue prior to said surface falling off said soft tissue.
- [0085] There is also provided in accordance with an exemplary embodiment of the invention, a two part anchor, comprising:
- [0086] an anchor portion adapted to be anchored to soft tissue and including an attachment element; and
- [0087] a selectively attachable rider portion adapted to be attached to said attachment element. Optionally, the anchor comprises a sensor coupled to said rider portion. Alternatively or additionally, said anchor portion is adhesive to said soft tissue. Alternatively or additionally, said anchor portion mechanically attaches to said soft tissue.

## BRIEF DESCRIPTION OF THE DRAWINGS

[0088] Exemplary non-limiting embodiments of the invention will be described with reference to the following description of embodiments in conjunction with the figures. Identical structures, elements or parts which appear in more than one figure are preferably labeled with a same or similar number in all the figures in which they appear.

[0089] FIG. 1 shows a cervical anchor ring attached to an anchor area, according to an embodiment of the present invention;

[0090] FIG. 2 shows an alternative view of the cervical anchor ring of FIG. 1, according to an embodiment of the present invention;

[0091] FIG. 3 shows a cervical anchor caliper attached to an anchor area, according to an embodiment of the present invention;

[0092] FIG. 4 shows a coupling anchor area, according to an embodiment of the present invention;

[0093] FIG. 5 shows a probe and bioadhesive probe attachment, according to an embodiment of the present invention;

[0094] FIGS. 6A-6D illustrate the operation of a cervical anchor hook in its attachment to an anchor area, according to an embodiment of the present invention;

[0095] FIG. 7 shows a bioadhesive probe attachment, according to an embodiment of the present invention;

[0096] FIG. 8A shows pin anchor mechanisms for use in the birth canal, according to an embodiment of the present invention;

[0097] FIGS. 8B and 8C shows embodiments of a round pin anchor, according to an embodiment of the present invention;

[0098] FIG. 9 shows a wireless signaler, according to an embodiment of the present invention;

[0099] FIG. 10 shows an ultrasound sensor, according to an embodiment of the present invention;

[0100] FIGS. 11A-11C show a probe with a dissolvable expandable anchor tip, according to an embodiment of the present invention;

[0101] FIGS. 12A and 12B show a probe with deforming anchors in tissue, according to an embodiment of the present invention;

[0102] FIG. 13 shows a probe delivery apparatus, according to an embodiment of the present invention;

[0103] FIGS. 14A-14E show different probe anchor tip designs, according to an embodiment of the present invention; and

[0104] FIGS. 15A-15C show probes that differ in the location of a biodegradable section, according to an embodiment of the present invention.

## DETAILED DESCRIPTION OF EMBODIMENTS

[0105] FIG. 1 shows a cervical anchor ring 100 with an exemplary attachment mechanism that attaches to an anchor area 140, for example adjacent the birth canal, comprising

tissue of the birth canal of the mother, her cervix and/or the fetus, according to an embodiment of the present invention. Anchor ring 100 potentially fosters robust attachment of a probe wire extension of a rod 110 to cervical tissue. Further, anchor ring 100 allows easy attachment using, for example, one hand at the anchor area and the other hand outside the birth canal and/or both hands outside the birth canal. Additionally or alternatively, anchor ring 100 allows easy removal using, for example, both hands outside the birth canal and/or one hand at the anchor area and the other hand outside the birth canal. In an exemplary embodiment, these potential advantages, for example one hand attachment from inside or outside the birth canal are able to be configured on all embodiments of the present invention described below.

[0106] In an exemplary embodiment, rod 110 passes through anchor area 140 with a sharp end 104 to secure cervical anchor ring 100 to anchor area 140. In an exemplary embodiment, multiple anchor rings 100 are packaged together in a single application kit that are appropriate for attachment at multiple sites, for example to the fetal scalp and/or one or more areas of tissue adjacent the birth canal, cervix and/or external to the mother. Optionally, the multiple electrodes apply separately to each area of tissue adjacent the birth canal and are removed separately from each area adjacent the birth canal and attach and/or remove in any order, at any time prior, during and/or following the birth process. Additionally or alternatively, the electrodes may be applied singly and/or in any combination to the birth canal tissue, for example so one or more probes are attached to the mother and not the fetus, for example prior to the breaking of the amniotic sac. Additionally or alternatively, multiple anchor rings 100 are utilized in other monitoring procedures, for example EKG and/or EMG testing and, in fact, all the anchor devices shown as exemplary embodiments of the present invention, can be utilized with a variety of monitoring procedures.

[0107] For rod 110 to pass through anchor area 140, sharp end 104 substantially removes from a receptacle 106 by pulling rod 110 in a direction 134. With sharp end 104 retracted from receptacle 106, anchor area 140 is placed between sharp end 104 and receptacle 106 and rod 110 is moved in a direction 132 to secure in anchor area 140 for example by a spring 120. In an exemplary embodiment, spring 120 has a first end 130 that presses against a housing stop 128 and a second end 122 that presses against a rod cam 124. With sharp end 104 retracted from receptacle 106, spring 120 is compressed in direction 134, creating pressure between rod cam 124 and housing stop 128.

[0108] As can be appreciated, some embodiments of the present invention provide an anchor ring 100 that can be configured for placement with either left or right hand by a single operator as the same device is easily operated ambidextrously. Additionally or alternatively, in an exemplary embodiment of the present invention, anchor ring 100, as is the case with other embodiments of the invention, can be placed in position by a single operator, for example an obstetrician, without additional assistance.

[0109] When rod 110 is released, it moves in direction 132, extending further out of a housing 108 toward anchor area 140 due to pressure of spring 120. Sharp end 104 passes through anchor area 140 and presses into receptacle 106 to attach cervical anchor ring 100 to anchor area 140. Addi-

tionally or alternatively, manual pressure in direction 132 is placed against an area of a shaft end 150 so that sharp end 104 passes through anchor area 140 into receptacle 106.

[0110] To remove cervical anchor ring 100 from anchor area 140 housing 108 is optionally stabilized with one hand, for example outside the birth canal, while rod 110 is pulled in direction 134 using the other hand, for example outside the birth canal, to cause sharp end 104 to move out of receptacle 106. Additionally or alternatively, one or both hands are placed in the birth canal during removal of anchor ring 100.

[0111] In an alternative embodiment, receptacle 106 is replaced with a sharp outcrop 142. When rod 110 is released and moves in direction 132, sharp end 104 and sharp outcrop 142 meet. This is useful in securing cervical anchor ring 100 directly to tissue anchor area 140A as sharp end 104 more easily pierces tissue anchor area 140A when sharp outcrop 142 focuses pressure on tissue 140A at the tip of sharp end 104. In an exemplary embodiment, the ability for sharp end 104 to move toward anchor area 140 and/or away from anchor area 140A, is a feature that is shared with embodiments of the present invention described below and optionally provides an advantage by allowing safer and/or more secure attachment of anchor ring 100 and/or other probes described below.

[0112] In an exemplary embodiment, spring 120 is designed to exert force that retracts sharp end 104 from receptacle 106. To install, anchor 100 is placed over anchor area 140 with spring 120 pulling rod 110 in direction 134 so that sharp end 104 remains retracted from receptacle 106. Pressure is placed on rod 110, for example at an end 150, against the action of spring 120 to cause rod 110 to extend in direction 132, of housing 108, through anchor area 140. The maintenance of spring 120 in the retracted position until pressed in direction 134 potentially averts damage to tissue during insertion.

[0113] In an exemplary embodiment, rod 110 has notches 152 that digitate with housing stop 128 to lock rod 110 in position through anchor area 140. To remove cervical anchor ring 100 from anchor area 140, shaft end area 150 is pushed in a direction 154 to disengage rod 110 from housing stop 128. Rod 110 is then pulled in direction 134 and/or spring 120 automatically moves in direction 134, and sharp end 104 disengages from receptacle 106. In an exemplary embodiment during removal, sharp end 104 is retracted by spring 120 into housing 108, so possible harm to the fetus and/or mother is averted. In an exemplary embodiment, anchor ring 100 can be removed from the tissue of the birth canal at any time during the birth process.

[0114] Optionally, housing 108 and/or rod 110 as well as the materials comprising probe anchors in other embodiments of the present invention, comprise one or more of the following materials: polyurethane, mylar, elastomer, kevlar, nylon, or metal, based upon, for example, desired strength of material and/or resistance to reactivity with body fluids. The variation in materials in construction of housing 108 and/or rod 110, and other embodiments, for example, is based upon the resilience of tissue around anchor area 140 and/or 140A, the anticipated length of implantation, and/or the proximity of housing 108 and/or rod 110 to areas of increased pressure such as adjacent the birth canal. Optionally, housing 108 and/or rod 110 include, for example, a radiopaque area that

allows it to be visible in a radiographic picture, as optionally provided in other embodiments of the present invention. Other materials may be used as well, for example as known in the art.

[0115] In an exemplary embodiment, housing 108, for example, has a diameter of between 3.0 millimeters and 10 millimeters dependent upon desired stiffness, diameter of rod 110 and materials from which it is made. Rod 110, for example, has an outer diameter of between 1 millimeter and 3 millimeters, depending on the material strength, ductility and desired material stiffness. Other embodiments of the present invention, including their anchors and/or base to which the anchors are attached, may have similar diameters with similar size variation based upon similar application considerations.

[0116] Typically, during the birth process tissue area 140A expands. In an exemplary embodiment, tissue area 140A occupies a chord along the radius of rod 110. As tissue area 140A expands with the birth process, it occupies a larger chord along the radius of rod 110, without causing additional pressure on tissue area 140A that might cause discomfort to the mother. The advantage of allowing tissue expansion along a larger cord of a curved anchor attachment such as rod 110 applies to other similar embodiments of the present invention. Alternatively or additionally, curved anchor is elastic. Optionally, the anchor is placed to be parallel, orthogonal or at another angle to an expected maximal distortion direction.

[0117] Additionally or alternatively, housing 108 and/or rod 110 comprise a material that degrades, so that sharp end 104, for example, weakens so that it is readily deformed to allow housing 108 to break free of tissue anchor area 140A. Additionally or alternatively, housing 108 and/or rod 110 biodegrade over a period of time so that they fall off anchor area 140A by themselves. In an exemplary embodiment, sharp end 104 and/or rod 110 is manufactured from shape memory polymers (SMP's) that deform, for example, due to the heat buildup, for example, from a body tissue. Optionally, insulation is provided, to slow down heating to a critical temperature. Deformation of sections of anchor ring 100, allows removal of anchor ring 100 from a tissue 140A, for example, with reduced force following a base period of attachment, as will be explained below.

[0118] FIGS. 15A-15C show a schematic diagram of a probe 1500, each with a biodegradable section in a different location, according to different embodiments of the present invention. Probe 1500 comprises, for example, an anchor element 1510 that inserts into an anchor area, for example a biological tissue within the birth canal, that is connected with an isthmus 1512 to a probe body 1520. Probe 1500 contains an instrumentation section 1540 that, for example, houses an ultrasound sensor that is connected to probe body 1520 by a linkage 1550 that, for example, comprises sharp end 104 or other types of attachment means noted below in other embodiments, for example, allowing removal of instrumentation section 1540 from probe body 1520.

[0119] In FIG. 15A, biodegradable sections include anchor element 1510, isthmus 1512 and probe body 1520.

[0120] In FIG. 15B, biodegradable sections include anchor element 1510, isthmus 1512 and a front body wall 1560 adjacent isthmus 1512.

[0121] In FIG. 15C, biodegradable sections include anchor element 1510 and isthmus 1512.

[0122] In the various biodegradable probe 1500 embodiments, the anchor element 1510 is implanted into an anchor area that causes the biodegradation of the various biodegradable sections. At the end of the birth process, instrumentation section 1540, optionally including a wire extension to a monitor and/or an antenna that broadcasts information to a monitor, is removed by manipulating linkage 1550, optionally with a mechanism located remote from probe 1500, for example outside the birth canal. Following the removal of instrumentation section 1540, biodegradation continues in each of the probe designs, resulting in probe 1500 falling away from the anchor area.

[0123] In an exemplary embodiment, probe 1500, instrumentation section 1540, linkage 1550 and/or a wire extension, for example, are manufactured from an SMP that deforms, for example, due to the heat buildup from a body tissue, so that it falls away and/or can easily be broken away from tissue 140A following a base period of attachment. In other embodiments, a melting material is used which slowly softens, melts or degrades due to body heat, pH, temperature and/or other birth canal ambient conditions.

[0124] In an exemplary embodiment, instrumentation section 1550 comprises an ultrasound probe, for example, that contacts the tissue area with anchor 1510. To facilitate proper coupling between the ultrasound probe and the tissue area, for example, isthmus 1512 is designed so that instrument section 1550 contacts the tissue over a large area. Additionally or alternatively, a coupling gel is provided between the tissue interface and instrument section 1540. In an exemplary embodiment of the invention, for example in a two part anchor as described below, the anchor attachment method is designed to be rigid enough so that ultrasonic waves easily travel from the surface of the birth canal tissue. Alternatively or additionally, the design provides a short distance between the sensor and the surface. Other sensors, for example oximetry sensors may also have special contact requirements, which are optionally provided by the anchoring and probe design, for example, optical oximetry sensors may require contact with the surface. In a two part probe such as described below, anchoring go section may include an aperture through which the sensor can reach and contact the tissue.

[0125] FIG. 2 shows a cervical anchor ring 100 attached to anchor area 140A, comprising an anchor projection 212 that projects out of a surface 220 of a coupling 200, according to an embodiment of the present invention. Cervical anchor ring 100 is, for example, assembled outside the birth canal by passing rod 110 through a passage 222 of anchor area 140A to secure cervical anchor ring 100 to coupling 200. Alternatively, it is assembled in the birth canal, for example, after anchor area 140A is attached. In this case, anchor area 140A may include a guiding design (e.g., include a cone shaped depression) to assist in blind guiding of ring 100.

[0126] To install cervical ring 100 assembled on coupling 200, an operator holds coupling 200 with two fingers of one hand and either housing 108 and/or wire 110 with the other hand. In an exemplary embodiment, housing 108 and/or wire 110 are of a length that allows manipulation of cervical anchor ring 100 with one hand outside the birth canal and/or cervix.

[0127] Optionally, coupling 200 comprises one of the materials used in the manufacture of housing 108 and/or rod 110 above. Additionally or alternatively, these materials and/or other materials specified in the invention description, can be used in the manufacture of the various other exemplary embodiments described below.

[0128] Additionally or alternatively, coupling 200 comprises, for example, biodegradable materials and dissolves, deforms and/or weakens following, for example, a base period of time. Additionally or alternatively, coupling 200 comprises an adhesive layer 210 that is, for example, a biodegradable adhesive that attaches to tissue. Adhesive layer 210 biodegrades during attachment so that its adherence gradually weakens. After a base period of time, according to its composition that is formulated based upon its use, adhesive layer 210 biodegrades to an adherence strength below a specific threshold level. Below this threshold level, for example, it falls off said tissue and/or removes from said with little force applied by the operator.

[0129] When coupling 200 is used in monitoring the progress of a birth and is attached to, for example, tissue in the human birth canal, adhesive layer 210 and/or coupling 200 and/or anchor 100, biodegrades below the threshold adherence level described above, over a period of 18 to 24 hours and/or a period allowing it to remain affixed through a long delivery period, for example maximally 48 hours. Additionally or alternatively, adhesive layer 210 is designed to remain attached to tissue for a longer period of time, for example a few days. At the end of labor and/or when removal of coupling 200 is desired, an external causative factor, for example hyaluronic acid or an alcohol derivative, is applied to adhesive layer 210 to cause biodegradation within a short period of time, for example a few hours. An example of a biodegradable bone fastener whose degradation is increased by addition of an external causative factor, incorporated by reference herein is shown by Freedland in WO 01/49189.

[0130] In an exemplary embodiment, should the birth occur in a shorter time so that coupling 200 and/or adhesive layer 210 remain intact and attached to anchor area 140A, an anchor attachment for example rod 110, is pulled in direction 134, to retract sharp end 104 from receptacle 106, allowing easy removal of cervical anchor ring 100 from coupling 200. Optionally, rod 110 comprises a biodegradable material and, in an exemplary embodiment, rod 110 weakens and is easily broken away from coupling 200, as potentially would all embodiments of the present invention when removal is required following a short period of time.

[0131] Additionally or alternatively, coupling 200 and/or adhesive layer 210 can be configured to remain above an adherence threshold for relatively short periods of time, for example, for as short a period as a half an hour. The potential advantage of such a short adherence period is the ability to rapidly monitor a short period of contractures to determine various tissue parameters. In an exemplary embodiment, coupling 0.100 and/or adhesive layer 210 for short observation periods, for example a half hour or less, can be designed without consideration of blocking fetal passages as they would be rapidly removed at an early stage of the birth process. Following this short monitoring period, probes with the design features notes in the other embodiments of the invention can be placed along the tissue adjacent the birth canal.

[0132] A potential advantage of using coupling 200 and/or adhesive layer 210 in attaching a probe, for example anchor ring 100, to a tissue adjacent the birth canal is that should coupling 200 be placed improperly, anchor ring 100 can be disconnected from it and, optionally, attached to another coupling 200 placed adjacent the birth canal. Additionally or alternatively, when a probe, for example anchor ring 100, requires multiple placement areas along a tissue of the birth canal, multiple couplings 200 can be placed throughout the area and anchor ring 100 can be moved from coupling 200 to coupling 200 as needed.

[0133] In an exemplary embodiment, housing 108 and/or rod 110 contains one or more piezoelectric areas, for example area 166 and/or area 170 that provide ultrasound signals to a biological tissue associated with anchor area 140 and/or 140A. In an exemplary embodiment, a housing surface 102 and/or receptacle 106 are spaced so that they make contact with anchor area 140A to provide appropriate monitoring of the birth process. Additionally or alternatively, housing 108 and/or rod 110 contains a piezoelectric area 170 or 166 that receives ultrasound signals from the biological tissue. Examples of materials from which piezoelectric material 170 and/or 166 can be made include PZT-4, PZT-5 PZT-8 quartz and/or PVdF, all of which can be configured to ensure appropriate output and/or receiving capabilities. These transducer materials are commercially available, for example, from Staveland Sensor, Inc. of East Hartford, Conn. or from Boston Piezo-Optics Inc. of Bellingham, Mass. In an exemplary embodiment, housing 108 and/or rod 110 contains a conversion coupling that transforms ultrasound signals to radio-frequency (RF) signals. As noted herein, the coupling between material 170 and anchor area 140 is designed to optionally allow appropriate transmission of monitoring signals and, for example, are appropriate to utilize in all embodiments that incorporate sensors of the present invention.

[0134] Optionally, rod 110 is elongated with a wire lead that attaches to a monitoring device and/or an antenna lead that sends signals to a monitoring device. Optionally, anchor ring 100, and/or its leads, will not prematurely displace or block access to the birth canal due to its small size and robust connection. Anchor ring 100, for example, does not block the birth canal due to its small size. A potential advantage of some embodiments of the present invention is the provision of robust connection of anchor ring 100 to tissue 140A potentially prevents premature disconnection and allows repeated manipulation of the leads out of the path of the birth canal, without risk that anchor ring 100 will displace and/or remove from tissue 140A. Additionally or alternatively, the small size and potentially robust connection of anchor ring 100 and/or other embodiments allows the mother to move freely during the birth process, for example, leaning on the bed and/or walking.

[0135] FIG. 3 shows a cervical anchor caliper 300 with a monitor wire 330 attached to an area of tissue 364, according to an embodiment of the present invention. Anchor areas 342 and 344 are, for example, tissue connection points for sharp ends 322 and 324 respectively adjacent the birth canal of the mother and/or on the fetal head. Additionally or alternatively, anchor areas 342 and 344 are part of a tissue area 364 of another body area, for example, skin and/or a mucosa. By attaching to two points along tissue 364, anchor caliper 300 potentially provides robust, safe attachment to anchor areas

342 and 344. In an exemplary embodiment, sharp end 322 and/or 324 are easily manipulated during attachment with one hand pressing upper leg areas 352 and/or 354. The other hand, for example, is positioned on wire 330, remote from tissue 364 and/or external to the birth canal, and aids in stabilizing anchor caliper 300 during attachment.

[0136] To secure cervical anchor caliper 300 to tissue 364, a leg 354, is pressed, so that it pivots on a pivot 314 and sharp end 324 moves in a direction 348 into tissue 344. Additionally or alternatively, a leg 352, is pressed so that it pivots on pivot 312 and pushes sharp end 322 in a direction 338 into tissue 342. In this manner sharp end 322 secures to tissue 342 and sharp end 324 secures to tissue 344 so cervical anchor caliper is attached to tissue 364.

[0137] In an exemplary embodiment, leg 352 is fixed to crosspiece 318 and does not pivot on pivot 312 and movement of leg 354 alone allows for tissue movement and/or expansion during the birth process. In an exemplary embodiment, fixed sharp end 324 is pressed into anchor tissue 342 with one hand and sharp end 324 is secured in anchor tissue 344 by manipulating wire 330 with the other hand, for example external to the birth canal.

[0138] In an exemplary embodiment, pivot 314 and/or pivot 312 allow legs 352 and/or 354 to move in response to tissue expansion as occurs, for example, during the birth process. Allowing for tissue expansion prevents undue discomfort to the mother and/or loosening of caliper 300, caused by expansion, thinning and/or movement of tissue 364 during the birth process. In an exemplary embodiment, expansion means for other embodiments of caliper 300 are included in other alternative embodiments of the present invention to allow comfort to the mother and/or fetus during the birth process.

[0139] In an exemplary embodiment, a spring 328 creates pressure to move sharp end 324 in a direction 350, toward anchor area 344 so that release of wire 330, for example, allows sharp end 324 to attach into anchor area 344. To release cervical anchor caliper 300 from anchor areas 342 and 344, wire 330 is manipulated, for example outside of the birth canal, causing sharp end 322 to move in direction 348, away from anchor area 342. Additionally or alternatively, the other hand is used to stabilize caliper 300, for example outside the birth canal, holding an extension of leg 352. In an exemplary embodiment, caliper 300 disengages from tissue areas 342 and 344 with a minimum discomfort to the mother. In an exemplary embodiment, spring 328 incorporates a mechanism that causes spring 328 to move in response to an electric current, for example provided from wire 330 that is configured as a conducting wire. This embodiment is applicable, for example, to all embodiment of anchors including spring mechanisms that cause movement of an anchor mechanism. In one exemplary embodiment of the invention, the electricity is used to heat a shape memory material that restraints the spring or forms a retraction element in itself.

[0140] In an alternative embodiment, spring 328 pulls sharp end 324 in a direction 360, away from anchor area 344 so that manipulation of wire 330 causes sharp end 324 to attach into anchor area 344. In an exemplary embodiment, after sharp end 324 has been manipulated to secure in anchor area 344, a holding bar 386 is pressed so that it encompasses legs 352 and 354 above crosspiece 318 maintaining the

extended position of sharp end 324. To remove caliper 300 from tissue 364, bar 386 is removed from its maintenance position, allowing sharp end 324 to retract in direction 360 by the action of spring 328, thus ensuring rapid removal of caliper 300 with both hands positioned outside the birth canal.

[0141] In an exemplary embodiment, attachment and/or removal of anchor caliper 300, and other exemplary embodiments of alternative anchor embodiments, are easily accomplished, for example, while the operator is wearing sterile gloves and, for example, while the birth canal and/or sterile gloves are coated with a lubricant, for example septalon. In an exemplary embodiment, caliper anchor 300 and/or one or more wires 330 are packaged in a sterile package that can be opened, for example, by a non-sterile assistant and/or passed to the operator, for example the obstetrician. Additionally or alternatively, caliper anchor 300 and/or one or more wires 330 can be transported in a tray of sterilizing liquid from which they are taken by the operator during the installation procedure. Additionally or alternatively, a probe wire, for example that is not sterile, is attached to the skin of the patient to provide grounding of anchor probe 300. Optionally following use, caliper anchor 300 and/or one or more wires 330 are easily deposited in a standard disposal container in the operating theater.

[0142] FIG. 4 shows coupling 200 by which an anchor, for example caliper anchor 300, attaches to tissue area 364. In an exemplary embodiment, coupling 200 has an anchor projection 344' and an anchor projection 342' and is attached to tissue 364 with adhesive layer 210. Anchor projection 342' has a passage 372 that is designed to receive sharp end 322 of cervical caliper 300. Anchor projection 344' has a passage 374 that is designed to receive sharp end 324 of cervical anchor caliper 300. Cervical anchor caliper 300 is secured to coupling 200 when sharp ends 322 and 324 are in passages 372 and 374 of anchor projections 342' and 344'. In an exemplary embodiment, caliper 300 is assembled with coupling 200 prior to insertion into the birth canal so that attachment of bioadhesive 210 can be accomplished so while holding coupling 200 with, for example, two fingers. Additionally or alternatively, as with other anchor embodiments, a variety of areas of caliper 300 may comprise biodegradable materials and/or SMP's so that caliper 300 weakens, deforms and/or dissolves for easy removal.

[0143] FIG. 5 shows an alternative embodiment of a probe apparatus 500 that allows attachment of a sensor 522 to tissue 506 with a force-operable release mechanism, providing an advantage of easy removal of probe 500. In an exemplary embodiment, probe 500 comprising a sensor 522 within a housing 516 attached to an area of tissue 506 with an adhesive attachment 512, according to an embodiment of the present invention. Sensor 522 is removed from housing 516, for example, by pulling a wire 524, for example, external to the birth canal. Additionally or alternatively, sensor 522 and/or wire 524 are removed from housing 516 by exerting force directly on sensor 522, for example internal to the birth canal.

[0144] In an exemplary embodiment, adhesive layer 512 and/or housing 516 are biodegradable and degrade until housing 516 falls away and/or completely dissolves, for example, sometime after completion of the birth process. Additionally or alternatively, adhesive layer 512 and/or

housing 516 partially degrade so that housing 516 and/or adhesive 512 weaken below a specific threshold level and are removed with relatively little force, for example following the birth process.

[0145] In an exemplary embodiment, sensor 522 is held in a sensor compartment 530 of housing 516 by bendable shoulders 532 and 534. Shoulders 532 and 534 secure sensor 522 in sensor compartment 530 against displacement forces that are typically generated in the birth canal.

[0146] To remove sensor 522 from sensor compartment 530, wire 524 and/or probe 550, for example, are pulled in a direction 540 causing sensor 522 to press shoulder 532 in a direction 552 and press shoulder 534 in a direction 554 until shoulder 532 and/or 534 move sufficiently to allow sensor 522 to pull out of compartment 530.

[0147] In an exemplary embodiment, removal of sensor 522 from compartment 530 is accomplished while adhesive layer 512 remains attached to tissue 506 without causing shearing separation within tissue 506. In an exemplary embodiment, the force required to bend shoulder 532 and/or shoulder 534 is between 2 and 3 Newtons, though it could be 4 or more Newtons and/or 0.5 Newtons or less, dependent, for example, on the strength of the connection between bioadhesive layer 512 and tissue 506 and/or the magnitude and/or direction of forces expected during birth. In an exemplary embodiment, a greater force is required in order to separate housing 516 from tissue 506 and/or causing shearing separation within tissue 506 so that housing 516 remains attached to tissue 506 following removal of sensor 522 from compartment 530.

[0148] Housing 516 is shown adhered in a perpendicular position to tissue 506. Additionally or alternatively, housing 516 can be designed to be adhered with the visible surface of housing 516, as seen in FIG. 5, parallel to the surface of tissue 506.

[0149] Optionally, housing 516 includes an aperture in its bottom, through which a sensor portion and/or protrusion of sensor 522 can directly contact the tissue. This type of design may also be used where housing 516 is attached to the soft tissue using a mechanical means, such as a spike or using methods described herein for other embodiments.

[0150] FIGS. 6A-6D illustrate the operation of a cervical anchor hook 600 that attaches to an anchor area 684 with a handle 634 that operates, for example, external to the birth canal in an exemplary embodiment, FIG. 6A shows a spring-loaded semi-circular hook 610 within a tunnel 614 in a housing 616 with a sharp end 690. Hook 610 rotates around a pivot hinge 612 that is attached to housing 616.

[0151] In an exemplary embodiment, a spring, not shown, causes cervical hook 600 to press out of tunnel 614. An engagement pin 618 in a pin passage 622 is pressed against hook 610 by a spring 620, locking hook 610 inside housing 616, preventing hook 610 from exiting housing 616. Pin 618 prevents movement of hook 610, for example, either by the friction between pin 618 tip and hook 610 or through articulating with a hook notch 688.

[0152] In FIG. 6B, engagement pin 618 has been retracted, allowing hook 610 to travel in a curved trajectory 686, exit housing 616 and pierce through a tissue area 684. Pin 618 presses forward to secure against an elbow 682 to

maintain hook 610 attached to tissue 684. Optionally, the closing spring disengages from hook 610, once hook 610 is secured.

[0153] FIG. 6C shows an activation mechanism 602 of cervical anchor hook 600, comprising a tube 630 that houses a cable 628, attached at one end to pin 618 and at the other end to handle 634. Pin 618 is retracted within pin passage 622.

[0154] In an exemplary embodiment, hook 610 normally remains in tunnel 614 by a spring action that presses hook 610 in a direction 666 (this force may be smaller, for example, than the force exerted by the not shown closing spring). In this fashion, housing 616 can be manipulated into position on tissue 684 without hook 610 causing irritation to tissue 684 or possibly catching on the fetus. With housing 616 in position, manipulation of tube 630, for example, causes hook 610 to travel in direction 686 to effect attachment to tissue 684. Once hook 610 is pressed through tissue 684, for example, pin 618 automatically extends out of housing 616 and presses elbow 682 to maintain hook 610 in the extended position.

[0155] To remove cervical hook 600 from tissue 684, for example, following completion of the birth process, pin 618 is retracted into housing 616, for example using cable 628 and hook 610 is pressed in direction 666 by spring action. In an exemplary embodiment, handle 634 is attached to grasp area 632 by a seal 652 that prevents inadvertent movement of handle 634 in relation to 632. Pulling on handle 634 while holding grasp area 632 breaks seal 652 and cable 628 pulls pin 618 into housing 616. As hook 610 is spring-loaded to travel in direction 686, it detaches from tissue 684.

[0156] Additionally or alternatively, pin 618 is pulled into housing 616 using, for example, a rotatable rod connected between handle 634 and pin 618, allowing retraction of hook 610. In an exemplary embodiment the rod is rotated to pull pin 618 into housing 616 and then detached from pin 618 following use, for example by continuing rotation following retraction of pin 618 into housing. Following detachment of the rod from pin 618, the rod is removed from the birth canal.

[0157] With hook 610 out of tissue 684, tube 630 and/or grasp area 632 are used to pull housing 616 from the birth canal, allowing removal of cervical anchor hook 600 from the birth canal with both operator's hands outside the birth canal.

[0158] In an exemplary embodiment, in FIG. 6D, handle 634 is attached to cable 628 and pulling handle 634 in a direction 650 in relation to a grasp area 632 causes cable 628 to retract pin 618 away from hook 610. Spring-loaded hook 610 exits housing 616 and pierces through tissue 684 so that cervical anchor hook 600 is attached to tissue 684. Housing 616 contains a sensor area 624 that monitors the subject through tissue 684.

[0159] In an exemplary embodiment, tube 630 has a widening 680 that ends in a washer 678 attached to a pivot control 636. In an embodiment where hook 610 is normally held in housing 616, by stabilizing grasp area 632 with one hand and rotating handle 634 with the other hand in a direction 674, movement of hook 610 out of tissue 684 is effected. In an embodiment where hook 610 is normally extended from housing 616, rotation of handle 634 in a

direction 676, while holding grasp area 632, causes hook 610 to retract into housing 616.

[0160] FIG. 7 shows an alternative embodiment of a probe apparatus 700 that allows attachment of a probe 720 to tissue with a non-mechanical hookup. Probe 700 has a bioadhesive probe attachment 700 with a probe wire 712 that attaches to coupling 200, according to an embodiment of the present invention. Optionally, probe attachment 700 has a bioadhesive layer 710 that is biodegradable to attach to surface 220 of coupling 200.

[0161] Probe attachment 700 comprises, for example, silicone or other non-dissolving and/or biodegradable materials specified in relation to the composition of coupling 200 while bioadhesive layer 710 may be similar in composition to that of adhesive layer 210.

[0162] In birth monitoring, for example, adhesive layer 710 biodegrades in the same fashion as does adhesive layer 210, over a period of time and/or through the addition of an agent or energy. For example, electromagnetic waves, such as heat, ultrasound or electricity, are applied in the vicinity of the flat section to cause dissolution of bioadhesives 710 and/or 210, probe 720, wire 712 and/or coupling 200. In an exemplary embodiment, electromagnetic waves are applied through an independent applicator that is brought near adhesive layer 710. Additionally or alternatively, wire 712 provides electric, heat or ultrasound energy that aids in of bioadhesives 710 and/or 210, probe 720, wire 712 and/or coupling 200.

[0163] FIGS. 8B and 8B shows some embodiments, of the many potentially different embodiments, of an anchor embodiment used in attaching a probe, for example, to a fetal scalp. In an exemplary embodiment, these embodiments, as other embodiments presented according to the present invention, can be used interchangeably for the fetal head and/or the birth canal. In addition, it should be noted that while some of the anchors described herein are especially useful for difficult to attach tissue, such as cervical tissue, which distorts, is mucal and/or experiences pressure and distortion during contraction and passage of the fetus and fetal scalp tissue which is wet and/or experiences large shearing forces during delivery, the anchors may be attached to other tissue, such as in the GI tract or in the mouth.

[0164] In an exemplary embodiment, FIG. 8A shows a straight pin anchor 800 with a housing 804 containing a sensor 808. Housing 804 is attached to a shaft 818 and has a hook 802 that embeds in a target tissue, for example the fetal head. To secure hook 802 into the target tissue, one of the operator's hands is placed on housing 804 and a second hand, outside the birth canal, is used to guide placement, for example, by holding onto a sheath 828 that covers shaft 818. Sensor 808 sends signals to a monitor, for example, connected with a wire 830.

[0165] FIG. 8B shows a round pin anchor 810 with a housing 814 containing sensor 808 with a with a round pin 812. In an exemplary embodiment, housing 814 is placed against a target tissue area and rotated to embed round pin 812 into the tissue.

[0166] Additionally or alternatively, housing 814 is attached to shaft 818. By rotating shaft 818 in relation to sheath 828, round pin 812 rotates and, when held against a target tissue, embeds into the target tissue. Rotation of shaft

**818** is accomplished, for example, by rotating a grasp area **820** with one hand while stabilizing sheath **828** with the other hand. In removing pin anchor **800**, both hands operate, for example, outside the birth canal, with one hand on sheath **828** and/or a shaft stabilizer **832** and the other hand is used to rotate grasp area **820**, causing round pin **812** to rotate out of the tissue area tissue.

[0167] FIG. 8C shows an alternative embodiment of round pin anchor **810** in which sensor **808** sends signals to a monitor through wire **830** and auxiliary wires **806**. In an exemplary embodiment, wire **830** sends an ultrasound signal to provide positioning information and auxiliary wires **806**, for example, transmit additional data from anchor area, for example, providing monitoring of the fetal heartbeat. Additionally or alternatively, wires **806** and/or **830** are connected to probes that are attached to tissue and provide measurement of EMG, optical devices, for example, for glucose monitoring and/or other skin-attached probes.

[0168] In an exemplary embodiment, wires **806** and/or **830** are color coded so that the operator is notified of the functions that sensor **808**, for example, provides. Additionally or alternatively, the color coding allows proper attachment to an appropriate monitor. Additionally or alternatively, wires **806** and/or **830** and/or round pin anchor **810** are color coded and/or labeled in a manner that notifies the operator of the proper placement, for example on the fetal head and/or on the, os cervix. Additionally or alternatively, wires **830** and/or **806** and/or round pin anchor **810** are color-coded and/or labeled in a manner that notifies the operator of proper placement on the skin, for example, for EKG and/or EMG monitoring. Such visual coding, for example, is available on other embodiments of the present invention as well.

[0169] Optionally, wires **806** and/or **830** are connected to one or more antennae that broadcast signals to a signal receptor that sends the signals to a monitor. In an exemplary embodiment, the different signals are broadcast in different formats so that they do not interfere with one another. For example, the positioning sensor provides ultrasound that operates in MHz, providing information on the relationship of the fetal crown to the birth canal. The ECG information is, for example, projected in the Hertz band. Additionally or alternatively, both sensors can operate in the MHz band and/or the Hz band, with significant separation of frequency to prevent interference. ECG information may be provided, for example, using one or more electrodes **168** (shown in FIG. 1), which may alternatively or additionally used for other sensing purposes.

[0170] FIG. 9 shows a wireless signaler **900** that transmits, for example, RF signals. In an exemplary embodiment, signaler **900** comprises housing **804** in which an incoming ultrasound energy **912** is converted by an RF converter **910**, for example, to electromagnetic RF energy **914**, possibly of same or similar frequency. RF energy **914** is then detected by a nearby detector (not shown) and shown, for example, on a display. Further details of an exemplary embodiment are provided for example in the above referenced PCT application file don even date.

[0171] In an exemplary embodiment, housing **804** contains straight hook **802** and a moveable pin **944**. To anchor wireless signaler **900** in tissue, for example, hook **802** is pressed into the tissue. Moveable pin **944** is retracted away

from hook **802** using shaft **818** and pressed against the tissue. Shaft **818** is then moved to cause moveable pin **944** to move toward hook **802** so that the tissue is secured between hook **802** and moveable pin **944**. Optionally, shaft **818** is spring-loaded so that upon release it moves toward hook **802** without further effort.

[0172] In an exemplary embodiment, to remove housing **804** from an anchor area **840**, sheath **828** is stabilized with one hand. Grasp area **820**, attached to shaft **818**, is manipulated so that moveable pin **944** moves away from hook **802** so that housing **804** removes from anchor area. As in other embodiments, both hands may be outside the cervix during removal.

[0173] Additionally or alternatively, shaft **818** is spring-loaded so that upon release, it moves away from hook **802**. In an exemplary embodiment, grasp area **820** moves shaft **818** forward against the pressure of its spring, while stabilizing sheath **828**. A ratchet (for example similar to notches **152** in FIG. 1) is located between shaft **818** and grasp area **820** and manipulated to keep moveable pin **944** in position toward hook **802** during childbirth. Following childbirth, the ratchet mechanism between shaft **818** and grasp area **820** is released so that moveable pin **944** retracts away from hook **802** and housing **804** is easily removed from the target tissue.

[0174] FIG. 10 shows ultrasound sensor **1000**, for example that sends and receives ultrasound signals. In an exemplary embodiment, sensor **1000** can be used, for example, in housing **804**. A small piezoelectric transducer **1048** has two active faces **1046** that are soldered, for example, to a coaxial cable **830A**. Additionally or alternatively, a twisted pair wire **830A** may be used.

[0175] FIGS. 11A-11C show a probe **1100** in a tissue **1184** with an expanding anchor tip **1102** that is adapted for use in soft tissue, for example adjacent the birth canal and that, for example, deflates and/or biodegrades following use. In FIG. 11A, anchor tip **1102** is shown in the pre-expanded state following being pressed into tissue **1184**. In an exemplary embodiment, anchor tip **1102** exhibits rigidity sufficient to be pressed into soft tissue **1184** by moving probe **1100** toward tissue **1184**. Additionally or alternatively, an anchor delivery system provides a rigid deployer guide that, for example, surrounds anchor tip **1102** to aid in pressing it into tissue **1184**.

[0176] FIG. 11B shows anchor tip **1102** expanded causing side points **1104** and **1106** to press laterally into tissue **1184**. Expansion for anchor tip **1102**, for example, is through the introduction of a fluid, for example, sterile saline and/or inert gas. Additionally or alternatively, anchor tip **1102** can anchor in tissue **1184** with a variety of alternative shapes, for example a sphere or single side point **1104**. Removal of anchor tip **1102**, for example, is accomplished by deflating tip **1102**.

[0177] In an exemplary embodiment anchor tip **1102** is attached to a tube **1120** that extends outside the cervix and expansion and/or shrinkage is accomplished, for example, by pressing an expansion gasket to press a fluid into anchor tip **1102**. A stop **1124**, for example on tube **1120** and/or the expansion gasket, maintains the fluid under pressure during the expansion period. Shrinkage and/or deflation, is accomplished by releasing stop **1124** so the fluid exits anchor tip **1102**.

[0178] FIG. 11C shows a dissolvable embodiment of expandable anchor tip 1102 in which a stop 1124A is contained on probe 1100 and tube 1120 has been removed past stop 1124, leaving tube 1120 within probe 1100. Additionally or alternatively, tube 1120 and/or gasket 1124 are external to probe 1100, for example, as part of an antenna housing. Following a base period of time, expand anchor tip 1102 begins to deform so that side points 1104 and 1106 lose their shape and probe 1100 can be removed from tissue 1184. Additionally or alternatively, the walls of anchor tip 1102 become thinner after a base period of time so tip 1102 deforms to gradually release the fluid it contains.

[0179] Additionally or alternatively, expandable anchor 1102 has an internal expansion mechanism, that expands side points 1104 and/or 1106 automatically in response to an activation stimulus. An activation stimulus, for example, comprises increased pressure during insertion that cause an internal fluid reservoir to break and fill anchor 1102 with pressurized fluid. Additionally or alternatively, an activation stimulus comprises application of electromagnetic waves or a catalytic agent that causes a fluid reservoir to break.

[0180] FIGS. 12A and 12B show an alternative embodiment of a probe 1200 that uses SMP technology in attaching to and removing from tissue. In an exemplary embodiment, FIGS. 12A and 12B show probe 1200 made of, for example, shape memory polymers (SMP's) as identified in "Shape Shifters" in *Scientific American*, May 2001, noted above. An SMP is capable of changing shape in response to a temperature increase. With the addition of heat, for example from the body, an SMP deforms into a temporary configuration. Upon removal of the temperature increase an SMP will revert to its former shape. An SMP can be formulated to deform at a wide variety of temperatures. For example SMP's made of polyurethane recover their shape as the temperature drops to between 30 and 70 degrees Celsius. The temperature at which the change occurs, for example, is dependent upon the formulation of the polyurethane-based SMP. SMP's, for example, are biocompatible and capable of 400 percent shape recovery.

[0181] In an exemplary embodiment, springs 1220 and 1222 are made of an SMP and anchored to anchors 1250 and/or 1252 at one end and to anchors 1230 and 1232 at the other end.

[0182] After a base period of time, for example encompassing the delivery period, SMP springs 1220 and 1222, reach a deforming temperature and deform into a shape, as shown in FIG. 12B that causes retraction of anchors 1240 and/or 1242 into probe 1200 so that it can be removed from a tissue 1210.

[0183] In an exemplary embodiment, a biodegradable polymer wedge 1260 that biodegrades as a result of, for example hydrolysis in the wet tissue environment, is located adjacent to anchor 1240 and a biodegradable polymer wedge 1262 is located adjacent to anchor 1242. Polymer wedges 1260 and 1262, for example, dissolve over a base period of time, for example 12-24 hours and/or a period that encompasses, for example, a typical birth process. Thus, even as SMP springs 1220 and 1222 change, for example, within several hours and exert force to pull anchors 1240 and 1242 within probe 1200, they are prevented from retracting due to the interposition of wedges 1260 and 1262. Following dissolution of wedges 1260 and 1262, SMP springs 1220 and 1222 pull anchors 1240 and 1242 into probe 1200.

[0184] FIG. 13 shows a probe deployer apparatus 1300 that can be utilized in a sterile field, according to an embodiment of the present invention. Probe deployer 1300 has a well 1340 or other receptacle in which probe 1200 is held. Probe 1200 is shown with a coiled wire extension 1360 and anchor tips 1230 and 1232 in the retracted position. Probe deployer 1300 has a handle 1326 and a lever 1310 that ends in a trigger 1320. Lever 1310 pivots on a pivot 1328 so that as trigger 1320 is pressed in a direction 1312, lever 1310 moves in a direction 1346. As lever 1310 moves in direction 1346, a prong 1322 moves against anchor tips 1230 and 1232 to cause them to exit probe 1200 and anchor in tissue 1210.

[0185] Additionally or alternatively, lever 1310 moves in direction 1346, pressing probe 1200 out of well 1340 so that probe 1200 easily separates from deployer apparatus 1300 following implantation into the tissue, for example, adjacent the birth canal. In an exemplary embodiment, deployer apparatus 1300 installs probe anchor 1200 into tissue 1210, for example of the birth canal, in a single action and/or does not require further manual inspection. Additionally or alternatively, deployer apparatus 1300 is disposable following a single use. Additionally or alternatively, deployer apparatus 1300 can be used multiple times and sterilized between uses.

[0186] In an exemplary embodiment, the entire probe deployer apparatus 1300 is sterile and handled by an operator with sterile gloved hands. Additionally or alternatively, handle 1326 is not sterile, being handled by an operator wearing non-sterile gloves while, for example, the area of deployer 1300 near tissue 1210 is sterile. Additionally or alternatively, the parts of the deployer apparatus cartridge and/or anchor that come into contact with the tissue of the birth canal area are sterile. In an exemplary embodiment, one or more probe anchors 1200 are contained in a sterile cartridge that fits into the deployer apparatus 1300 and advance forward to deploy in tissue, for example, with a spring mechanism so that one probe 1200 is always ready to be deployed until there are no further probe anchors 1200.

[0187] In an exemplary embodiment, the deployer apparatus may be adapted for use with other anchors, for example as described herein, optionally, including a release mechanism suitable for the particular anchoring method used, for example, a pin retraction for the embodiment of FIG. 6. Alternatively or additionally, the deployer apparatus includes a control for attaching to the anchor release mechanism, for assistance in removal of the device, for example, a pulley to pull on the cable (in FIG. 6).

[0188] In an exemplary embodiment of the invention, the anchors are provided on a conveyer line, so that when one is deployed, the next comes into position. Alternatively or additionally, a spring is used to advance the anchors. Mechanisms similar to those used in surgical clip deployers may be used as well known in the art.

[0189] Optionally, deployer apparatus 1300 is equipped with a first positioning prong 1320 and/or a second positioning prong that aid in centering probe 1200 automatically on an external surface of the cervical os. Additionally or alternatively, positioning prongs 1320 and/or 1322 are radiopaque to aid in proper placement of probe 1200 on an external surface of the cervical os so that the operator can readily assess the position of probe 1200 using a radiographic imager suitable for imaging during deployment.

[0190] In an exemplary embodiment, probe 1200 remains in tissue 1210 for a base period of time, following which it deforms, dissolves and/or is modified in shape so that it can be easily removed from tissue 1210, for example, by pulling on wire extension 1360.

[0191] FIGS. 14A-14E show several embodiments of different probe anchor tip designs, according to an embodiment of the present invention that optionally are deliverable with probe delivery apparatus 1300, according to an embodiment of the present invention. In an exemplary embodiment, delivery apparatus 1300 delivers a wide variety of probe anchors including those shown in FIGS. 14a-14E, the various embodiments demonstrated as exemplary embodiments of the present invention. Additionally or alternatively, as can be readily appreciated, delivery apparatus 1300 can be modified in various ways in order to deliver any number of probes with designs other than those specifically shown.

[0192] FIG. 14A shows anchor tip 1102 attached to a probe base 1410 that is cylindrical, for example allowing it to interface with well 1340. In an exemplary embodiment, anchor tip 1102 is in the deflated position as shown in FIG. 11A and it is delivered to tissue 1184 with delivery apparatus 1300. In an exemplary embodiment, prong 1322 presses against cylinder 1410 and causes the release of a pressurized fluid to expand anchor tip 1102. Additionally or alternatively, following the birth process, or, when used in alternative tissue following use, probe delivery apparatus 1300 is used to pierce probe 1410 and release the pressure so that tip 1102 deflates.

[0193] FIG. 14B shows a modification of round pin 812 that demonstrates more circular revolutions than round pin 812 pictured in FIG. 8B. In an exemplary embodiment, prong 1322 rotates as it moves in direction 1346. A probe 1400B, for example, is delivered to an anchor area and circular tip 810 rotates into the anchor area as prong 1322 presses on it in direction 1346, securing probe 1400B to the tissue. In an exemplary embodiment, following use of probe 1400B, delivery apparatus 1300 is attached to probe 1410 and, by causing prong 1322 to move in direction 1348, it reverses its rotation to cause round pin 812 to rotate opposite to its rotation during implantation, causing removal of probe 1400B.

[0194] FIG. 14C shows a probe 1400C with tip 1102 coupled with a pancake-shaped probe 1420. Pancake probe 1420 may have use where a low profile is important, for example in taking measurement within the pleural sac around the heart.

[0195] FIG. 14D shows probe 1400D with flexible tips 1130 that spread away from each other prior to deployment and contract toward each other to secure to a tissue. In an exemplary embodiment, prong 1322 presses into a passage 1338 of probe 1400D and presses against scissor ends 1436, causing the spreading of flexible tips 1130 away from each other. Release of prong 1322, for example, allow tips 1430 to contract toward each other and attach to an anchor area. In an exemplary embodiment, removal of probe 1400D is effected by pressing prong 1322 into scissor ends 1436, causing them to expand away from each other so that probe 1400D can be removed from the anchor area.

[0196] FIG. 14E shows probe 1400E with a pincer arm 1440 that has a slope edge 1452. Prong 1322, for example,

is pressed into a passage 1450 until its tip presses slope edge 1452, causing pincer arm 1440 to spread from a stationary arm 1442 as it pivots on a spring pivot 1454. Removal of prong 1322 from slope edge 1452, for example, allows pincer arm 1440 to move toward stationary arm 1442 and secure into an anchor area.

[0197] Removal of probe 1400E is effected by pressing prong 1322 into slope edge 1452, causing pincer arm 1440 to spread from stationary arm 1442 so that probe 1400D can be removed from the anchor area.

[0198] The present invention has been described using non-limiting detailed descriptions of embodiments thereof that are provided by way of example and are not intended to limit the scope of the invention. It should be understood that features and/or steps described with respect to one embodiment may be used with other embodiments and that not all embodiments of the invention have all of the features and/or steps shown in a particular figure or described with respect to one of the embodiments. Variations of embodiments described will occur to persons of the art.

[0199] Furthermore, the terms “comprise,” “include,” “have” and their conjugates, shall mean, when used in the claims, “including but not necessarily limited to.”

[0200] It is noted that some of the above described embodiments may describe the best mode contemplated by the inventors and therefore may include structure, acts or details of structures and acts that may not be essential to the invention and which are described as examples. Structure and acts described herein are replaceable by equivalents, which perform the same function, even if the structure or acts are different, as known in the art. Therefore, the scope of the invention is limited only by the elements and limitations as used in the claims.

1. A probe anchor that attaches a probe to a tissue adjacent a birth canal, comprising:

- (a) a soft tissue anchor including a release mechanism;
- (b) a cable sufficiently pliable that it will not harm a fetus during passage through the birth canal coupled at one end thereof to said release mechanism; and
- (c) a control coupled to an opposite end of said cable and operative to remotely release said release mechanism using said cable without requiring manual stabilization directly to said anchor.

2. A probe anchor according to claim 1 wherein said release mechanism is mechanically operated.

3. A probe anchor according to claim 1 wherein said release mechanism is electrically operated.

4. A probe anchor according to claim 2 wherein said release mechanism stores a releasing energy and whereby said control releases said energy.

5. A probe anchor according to claim 4 comprising an energy retainer that prevents activation of said releasing energy until its release by said control.

6. A probe anchor according to claim 1 wherein said probe anchor comprises two sections:

- (a) an anchor section that connects to said tissue and is adapted for the attachment of a probe section; and
- (b) a probe section that attaches to said anchor section.

7. A probe anchor according to claim 6 wherein said anchor section defines a volume suitable for receiving said probe section.

8. A probe anchor according to claim 7 wherein said probe section fits in said volume and is removably coupled to said volume.

9. A probe anchor according to claim 7 wherein said volume comprises one or more resilient projections that restrain said probe section from exiting said volume.

10. A probe anchor according to claim 9 wherein said resilient projections release said probe section from said volume upon application of a probe-displacing force.

11. A probe anchor according to claim 1 wherein said anchor section weakens over time, facilitating its removal from said tissue.

12. A probe anchor according to claim 11 wherein said anchor section partially dissolves over time.

13. A probe anchor according to claim 11 wherein said anchor section completely dissolves over time.

14. A probe anchor according to claim 11 wherein said anchor section deforms over time.

15. A probe anchor according to claim 14 wherein said deformation occurs in response to a temperature change.

16. A probe anchor according to claim 2 wherein pulling said cable away from said anchor activates said mechanical release mechanism.

17. A probe anchor according to claim 2 wherein rotating said cable around its axis in relation to said anchor activates said mechanical release mechanism.

18. A probe anchor according to claim 1 wherein said probe comprises a sensor that monitors said tissue.

19. A probe anchor according to claim 18 wherein said sensor comprises an ultrasound transducer ultrasonically coupled to said anchor section and ultrasonically coupled by said anchor section to said tissue.

20. A probe anchor according to claim 1 wherein said cable comprises a conducting wire.

21. A probe anchor according to claim 20 wherein said conducting wire carries signal data.

22. A probe anchor according to claim 20 wherein said conducting wire is visually coded to indicate function or placement of said conducting wire.

23. A probe anchor according to claim 20 wherein said conducting wire is connected to an antenna that transmits signal data.

24. A probe anchor according to claim 23 wherein said probe comprises an electromagnetic RF transmitter coupled to said antenna.

25. A probe anchor according to claim 1 wherein said anchor section is visually coded to indicate function or placement of said anchor section.

26. A probe anchor according to claim 1 wherein said anchor section is configured so it does not obstruct the birth canal during a birth process.

27. A probe anchor according to claim 1 wherein said anchor section is configured so it does not obstruct manual examination of the birth canal.

28. A probe anchor that attaches a probe to soft tissue adjacent a birth canal, comprising:

(a) an anchor that has a closed position and an open position;

(b) a tension element that urges said anchor toward said open position;

(c) a closure control operative to maintain said anchor in said closed position.

29. A probe according to claim 28 wherein said anchor comprises a wire passed through said tissue when said anchor is in the closed position.

30. A probe according to claim 28 wherein said anchor comprises one or more legs with sharp ends pressed into said tissue when said anchor is in the closed position.

31. A probe according to claim 28 wherein release of said closure control, allowing said anchor to return to the open position, is activated by an extension remote from said anchor.

32. A probe according to claim 28 comprising a tensioning element urging said anchor to be in said closed position.

33. A probe according to claim 28, wherein said anchor is adapted to change from a normal closed to a normally open configuration following attachment of said probe to soft tissue.

34. A probe anchor according to claim 28 wherein said tension element comprises a shape memory polymer.

35. A probe anchor according to claim 34 wherein said shape memory polymer is coupled to a delaying mechanism that delays said opening of said anchor.

36. A probe anchor according to claim 35 wherein said delaying mechanism comprises a material that biodegrades over a period of time during which period it prevents said a shape memory polymer from drawing said anchor into the open position.

37. A probe anchor according to claim 35 wherein said delaying mechanism comprises a material that dissolves in response to an external causative factor.

38. A probe that anchors in soft tissue adjacent a birth canal, comprising:

a probe defining one or more lumens;

a spike element set in each of said one or more lumens with a front end extending out of said lumen; and

a deforming element that deforms in response to temperature increase above a base temperature, connecting said spike to said lumen;

wherein deformation of said deforming element causes said front end of said spike to retract into said lumen.

39. A probe according to claim 38 wherein said lumen includes a delay plug that prevents retraction of said spike element.

40. A probe according to claim 39 wherein said delay plug comprises a material that weakens over a period of time.

41. A probe according to claim 39 wherein said delay plug prevents retraction of said one or more spike elements for a minimum of eight hours.

42. A probe according to claim 39 wherein said delay plug comprises a biodegradable material.

43. A probe according to claim 39 wherein said delay plug comprises a material that degrades in response to an external causative factor.

44. A probe according to claim 43 wherein said external causative factor comprises a compound.

45. A probe according to claim 43 wherein said external causative factor comprises electromagnetic waves.

46. An expanding probe anchor that attaches a probe to soft tissue adjacent a birth canal, comprising:

a probe with an expandable anchor member adapted to be inserted into said soft tissue;

- a fluid reservoir containing a fluid, external to said canal and connected to said expandable anchor by a fluid conduit; and
- a valve between said reservoir and said anchor that maintains said fluid in said anchor following its flow into said anchor from said reservoir.
- 47.** A probe according to claim 46 wherein said fluid reservoir is flexible and compression of said reservoir causes said fluid to move through said conduit into said anchor member.
- 48.** A probe according to claim 47 wherein movement of said fluid into said anchor member causes expansion of said anchor member.
- 49.** A probe according to claim 46 wherein said anchor member weakens over time and maintains said fluid for a base period of time following which it releases said fluid.
- 50.** A probe according to claim 49 wherein said release occurs following a minimum of eight hours.
- 51.** A probe according to claim 49 wherein said anchor member comprises a material that releases said fluid in response to an external causative factor.
- 52.** A probe according to claim 49 wherein said anchor member comprises a material that releases said fluid in response to a natural biological material contained in said canal.
- 53.** A probe anchor deployment apparatus that attaches a probe anchor to soft tissue adjacent a birth canal, comprising:
- (a) an anchor deployment apparatus with a grasping end that grasps a probe;
  - (b) a probe with an anchor mechanism suitable for attachment to said tissue;
  - (c) a handle extension extending from said grasping end out of said birth canal; and
  - (d) a deployment mechanism along said handle extension that deploys said anchor mechanism.
- 54.** Apparatus according to claim 53 wherein said apparatus is adapted to carry two or more probes.
- 55.** Apparatus according to claim 53 wherein said apparatus is adapted to carry two or more probes in a magazine.
- 56.** Apparatus according to claim 54 wherein a second probe moves into said grasping end following deployment of a first probe.
- 57.** Apparatus according to claim 53 wherein said anchor includes a release mechanism and wherein said apparatus is adapted to activate said release mechanism.
- 58.** An adhesive probe anchor, comprising:
- an adhesive on said probe that adheres to a mucosal surface adjacent a birth canal with sufficient adherence to resist detachment due to forces generated by the birth process for a base period of time; and
- a sensor removably connected to said probe.
- 59.** A probe according to claim 58 wherein said base period comprises a minimum of eight hours.
- 60.** A probe according to claim 59 wherein said adhesive weakens in response to biological compounds naturally contained within said canal.
- 61.** A probe according to claim 59 wherein said adhesive weakens in response to an external causative factor.
- 62.** A sensor according to claim 58 wherein said connection between said sensor and said probe is a mechanical connection.
- 63.** A sensor according to claim 58 wherein said connection between said sensor and said probe is a biodegradable connection that weakens over a base period of time during which it resists detachment due to forces generated by the birth process.
- 64.** A probe according to claim 63 wherein said wherein said base period comprises a minimum of eight hours.
- 65.** A probe according to claim 63 wherein said weakening occurs in response to biological compounds naturally contained within said canal.
- 66.** A probe according to claim 63 wherein said biodegradable connection weakens in response to an external causative factor.
- 67.** A method for securing an anchor, having a base and a curved wire having a point, to the cervix, comprising:
- (a) positioning said anchor at a tissue of the cervix such that said base contacts the cervix;
  - (b) transfixing said cervix with said curved wire, point first, so that said point is covered by said base when said transfixing is completed.
- 68.** A method according to claim 67 wherein said probe anchor comprises an ultrasound transducer ultrasonically coupled to said anchor and attaching comprises attaching said ultrasonically coupled transducer to said cervix.
- 69.** A method for adhering a probe with a sensor to soft tissue adjacent a birth canal and monitoring fetal passage, comprising:
- grasping a probe apparatus, including a sensor and an adherent surface that weakens over time;
- pressing said adherent surface onto said soft tissue;
- monitoring fetal passage through said canal with said sensor; and
- confirming the removal of said adherent surface from said soft tissue following its weakening below its adherence threshold.
- 70.** A method according to claim 69 wherein said confirming occurs following a minimum of eight hours of adherence.
- 71.** A method according to claim 69 wherein said weakening occurs in response to biological compounds naturally contained within said canal.
- 72.** A method according to claim 69 wherein said weakening occurs in response to an external causative factor.
- 73.** A method according to claim 69 wherein comprising removing said sensor from said soft tissue prior to said surface falling off said soft tissue.
- 74.** A two part anchor, comprising:
- an anchor portion adapted to be anchored to soft tissue and including an attachment element; and
- a selectively attachable rider portion adapted to be attached to said attachment element.
- 75.** An anchor according to claim 74, comprising a sensor coupled to said rider portion.
- 76.** An anchor according to claim 74, wherein said anchor portion is adhesive to said soft tissue.
- 77.** An anchor according to claim 74, wherein said anchor portion mechanically attaches to said soft tissue.

专利名称(译)	探针锚		
公开(公告)号	<a href="#">US20040153008A1</a>	公开(公告)日	2004-08-05
申请号	US10/480008	申请日	2002-06-05
[标]申请(专利权)人(译)	沙夫YEHUDA BETZALEL摩西		
申请(专利权)人(译)	沙夫YEHUDA BETZALEL摩西		
当前申请(专利权)人(译)	BARNEV LTD.		
[标]发明人	SHARF YEHUDA BETZALEL MOSHE		
发明人	SHARF, YEHUDA BETZALEL, MOSHE		
IPC分类号	A61B5/00 A61B5/024 A61B5/0448 A61B5/06 A61B5/07 A61B5/107 A61B5/11 A61B8/00 A61B8/08 A61B8/12 A61B17/42 A61D1/08 G01S13/74 G01S15/74 A61B5/103		
CPC分类号	A61B5/0031 A61B8/565 A61B5/0448 A61B5/06 A61B5/076 A61B5/1076 A61B5/1127 A61B5/6882 A61B8/0833 A61B8/0866 A61B8/12 A61B8/4281 A61B8/4472 A61B2503/02 A61B2562/226 A61B8/56 A61B5/02411		
优先权	60/295573 2001-06-12 US 60/338671 2001-12-11 US 60/295569 2001-06-05 US 60/309783 2001-08-06 US		
外部链接	<a href="#">Espacenet</a> <a href="#">USPTO</a>		

摘要(译)

一种探针锚，其将探针附接到与产道相邻的组织，包括：(a) 包括释放机构的软组织锚；(b) 足够柔韧的电缆，使其在通过产道的一端与所述释放机构连接时不会伤害胎儿；(c) 一个控制器，连接到所述电缆的另一端，并可操作以使用所述电缆远程释放所述释放机构，而不需要直接手动稳定到所述锚。

