



(19) **United States**

(12) **Patent Application Publication**  
**Zheng et al.**

(10) **Pub. No.: US 2003/0146385 A1**

(43) **Pub. Date: Aug. 7, 2003**

(54) **METHOD AND APPARATUS FOR  
ADJUSTING SIGNAL VARIATION OF AN  
ELECTRONICALLY CONTROLLED  
INFRARED TRANSMISSIVE WINDOW**

**Publication Classification**

(51) **Int. Cl.<sup>7</sup> ..... G01J 1/18**  
(52) **U.S. Cl. .... 250/339.04**

(76) **Inventors: Peng Zheng, Alameda, CA (US);  
Jennifer H. Gable, Walnut Creek, CA  
(US); W. Dale Hall, Oakland, CA (US);  
Kenneth G. Witte, San Jose, CA (US);  
James R. Braig, Piedmont, CA (US)**

(57) **ABSTRACT**

An analyte detection system non-invasively determines the concentration of an analyte in a sample generating a sample infrared signal indicative of the concentration of the analyte in the sample. The detection system includes a window assembly for receiving the sample infrared signal. The window assembly is adapted to allow the sample infrared signal to transmit therethrough, and generates a window infrared signal. The detection system further includes at least one detector configured to receive both the window infrared signal and the sample infrared signal transmitted through the window assembly. The detector is further adapted to generate a detector signal in response thereto. The detection system further includes a correction module configured to generate a corrected detector signal indicative of the concentration of the analyte in the sample.

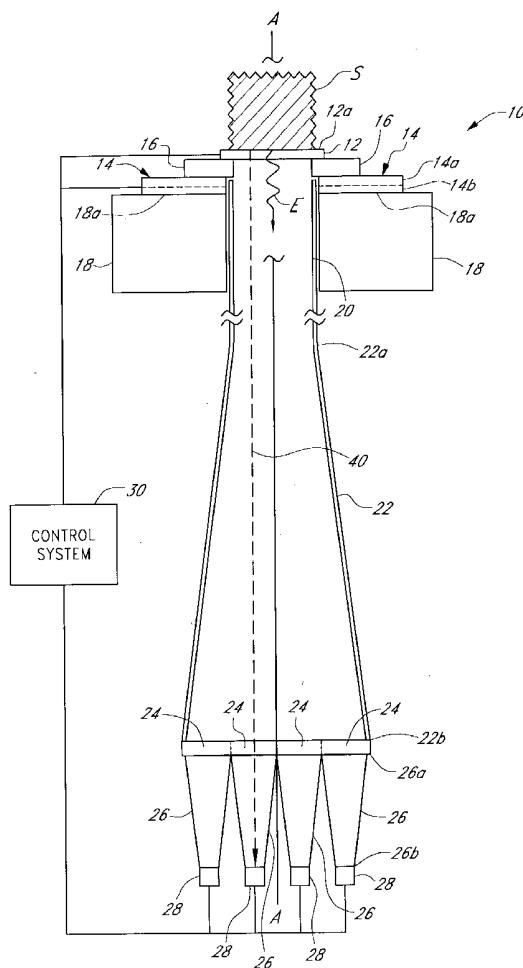
Correspondence Address:  
**KNOBBE MARTENS OLSON & BEAR LLP  
2040 MAIN STREET  
FOURTEENTH FLOOR  
IRVINE, CA 92614 (US)**

(21) **Appl. No.: 10/302,030**

(22) **Filed: Nov. 21, 2002**

**Related U.S. Application Data**

(60) **Provisional application No. 60/332,322, filed on Nov. 21, 2001.**



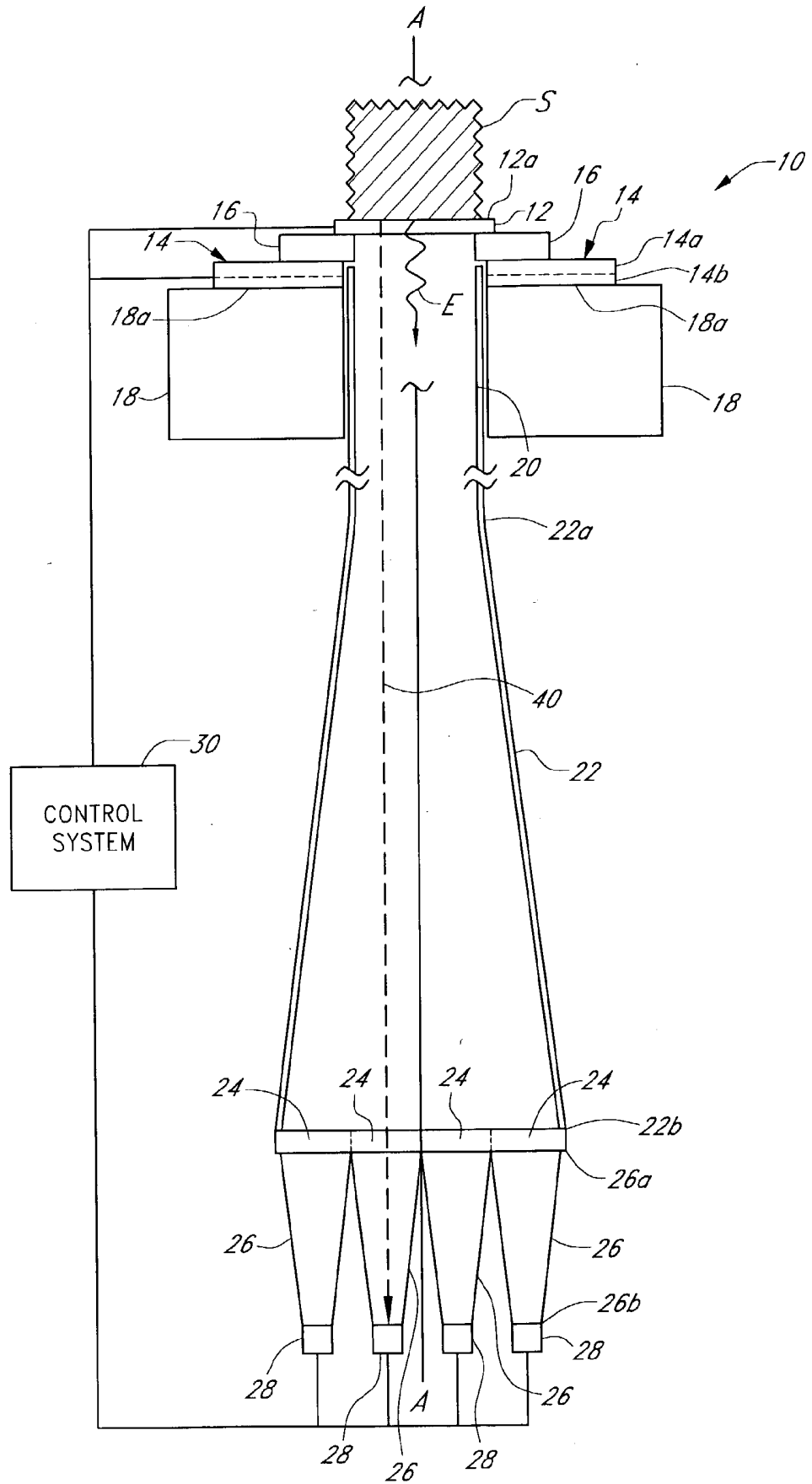
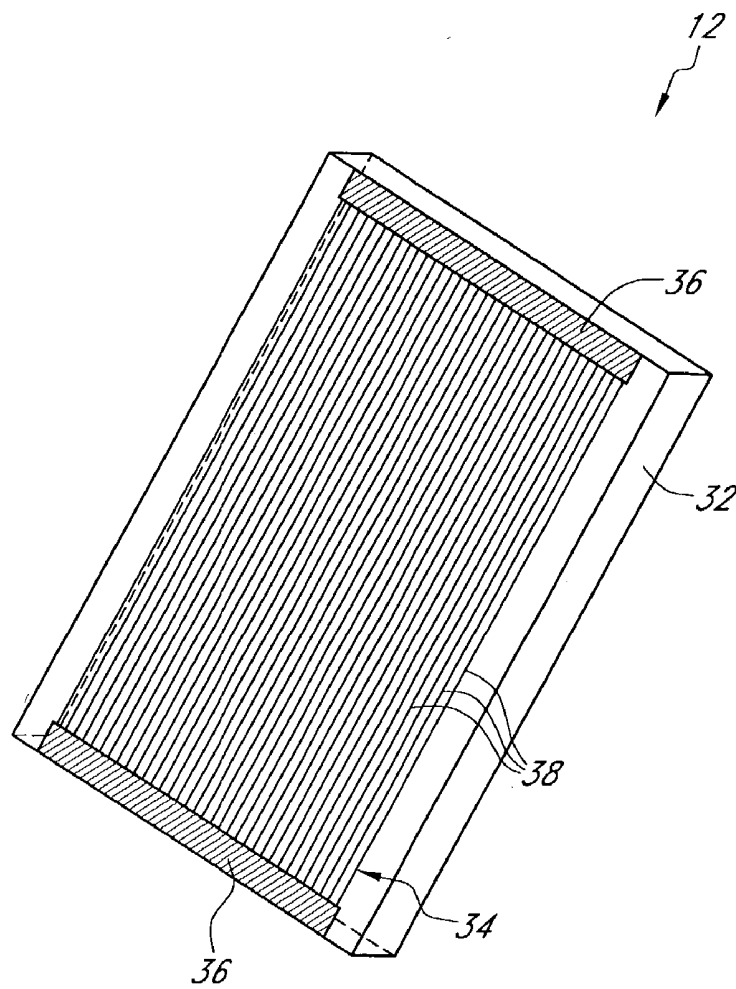


FIG. 1



*FIG. 2*

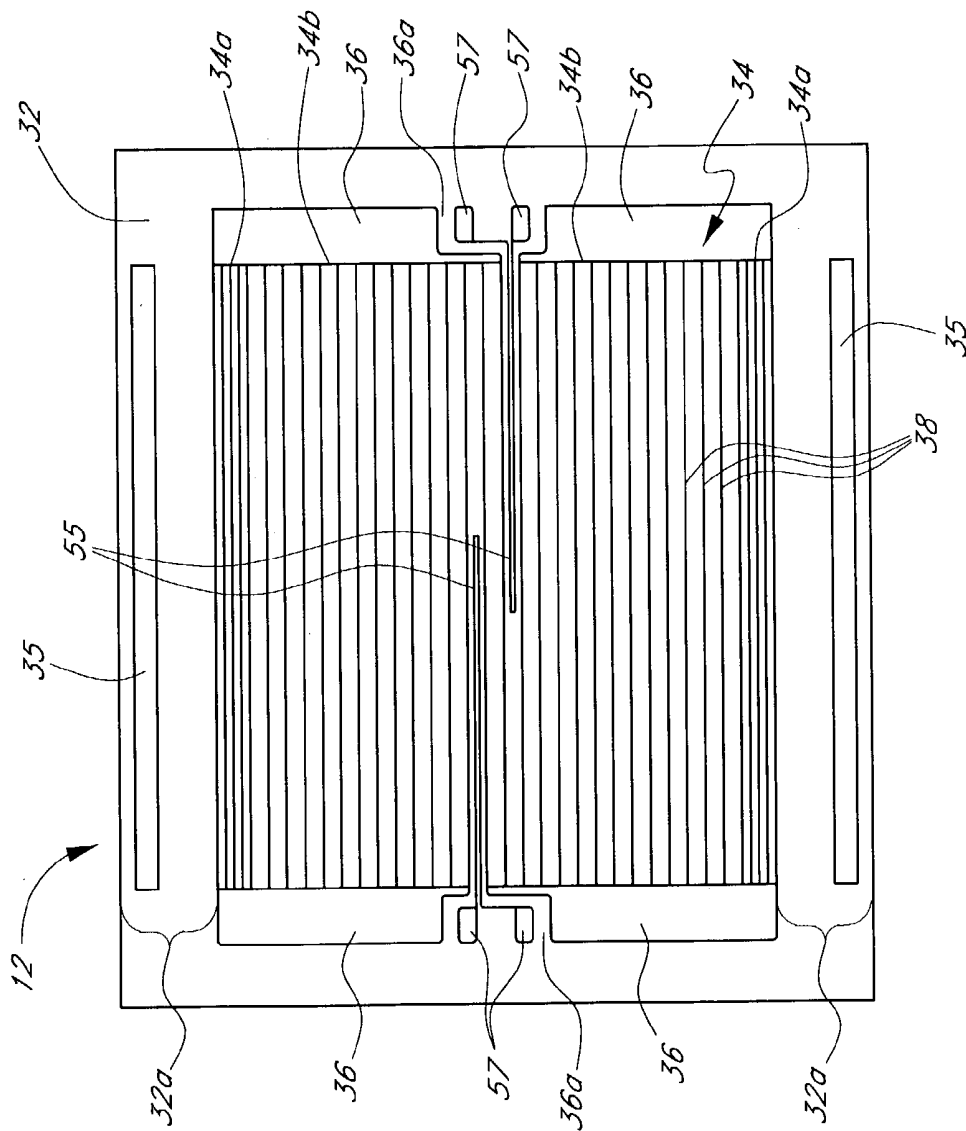
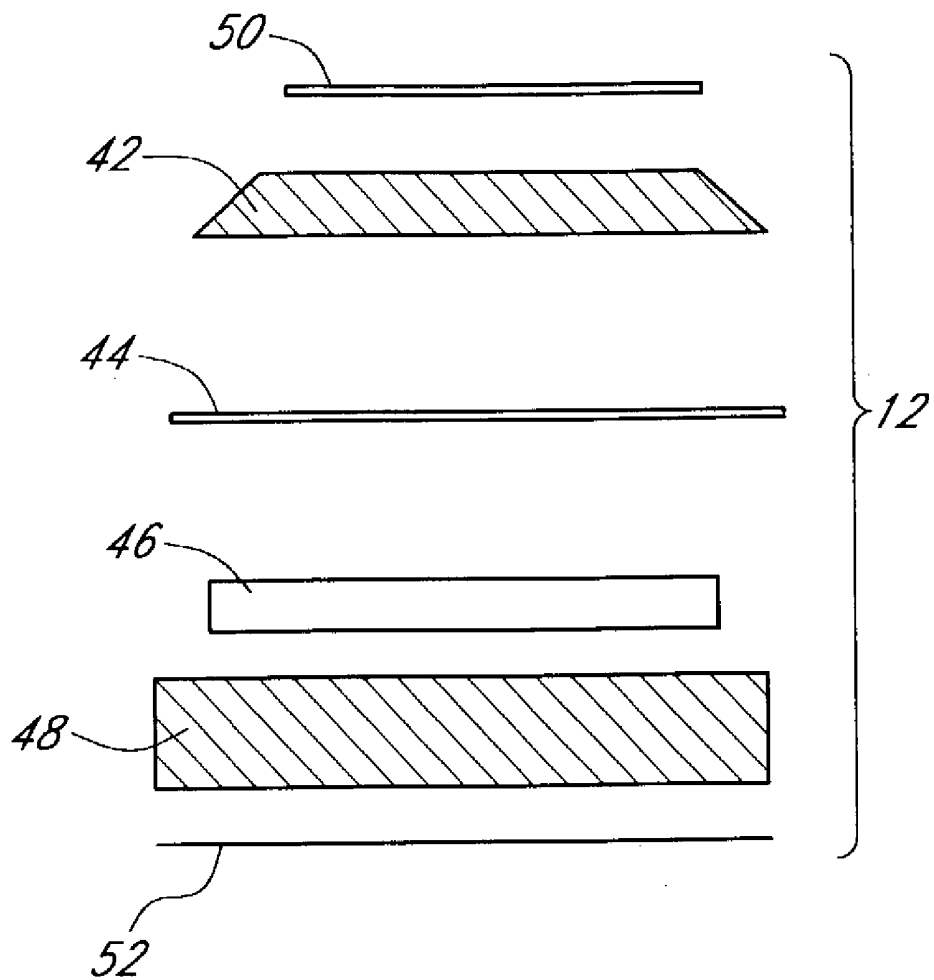
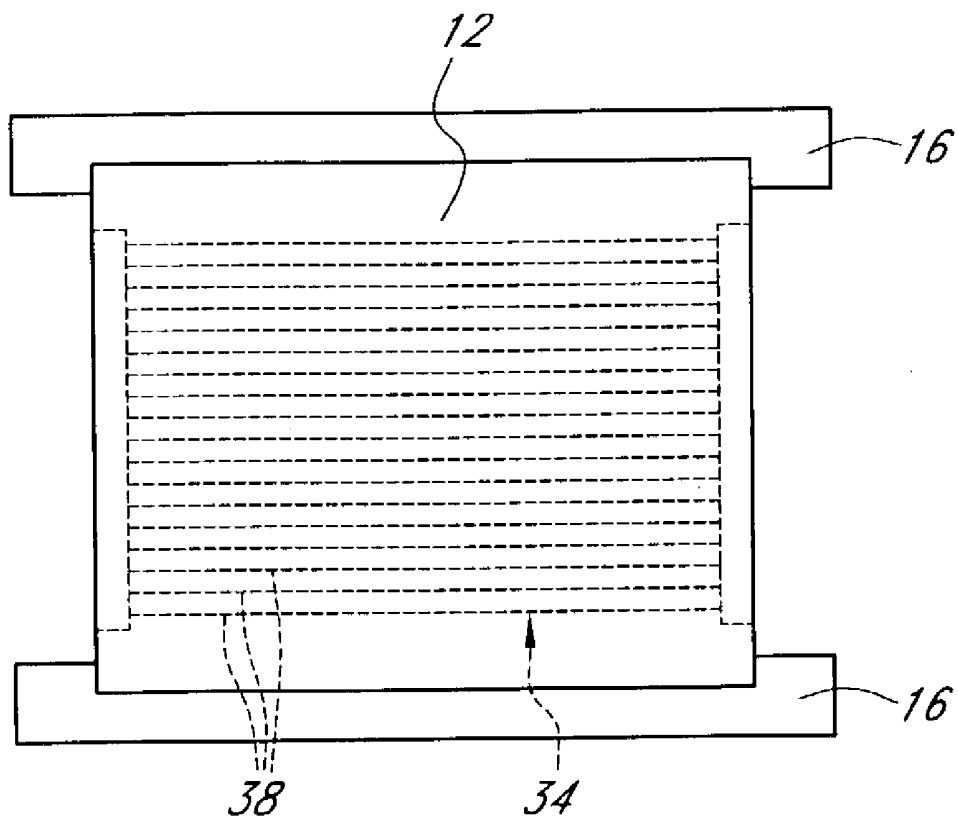


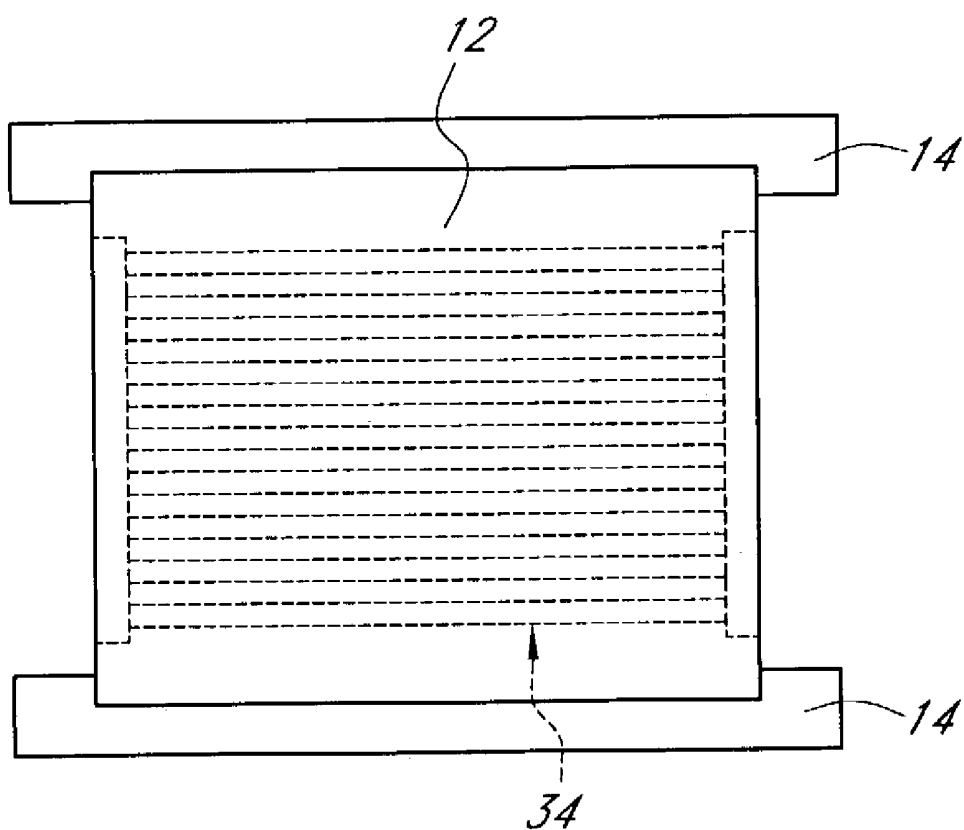
FIG. 2A



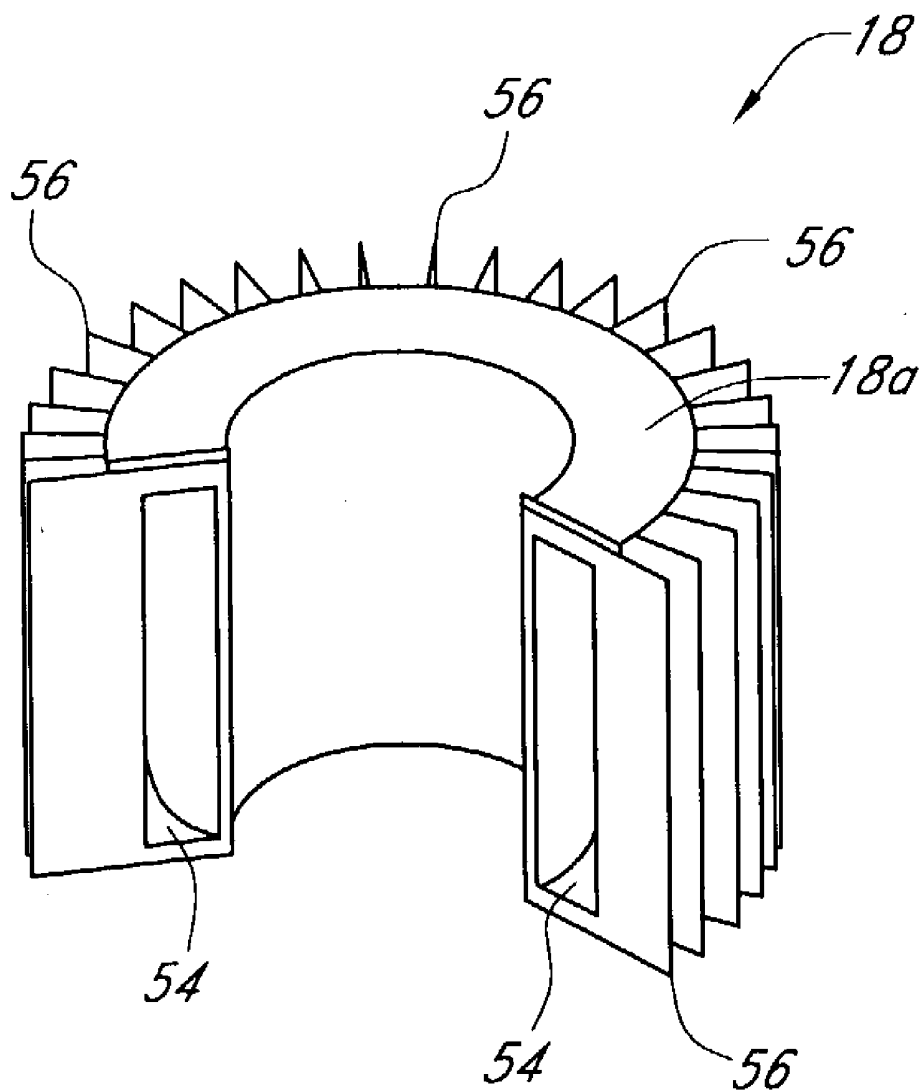
*FIG. 3*



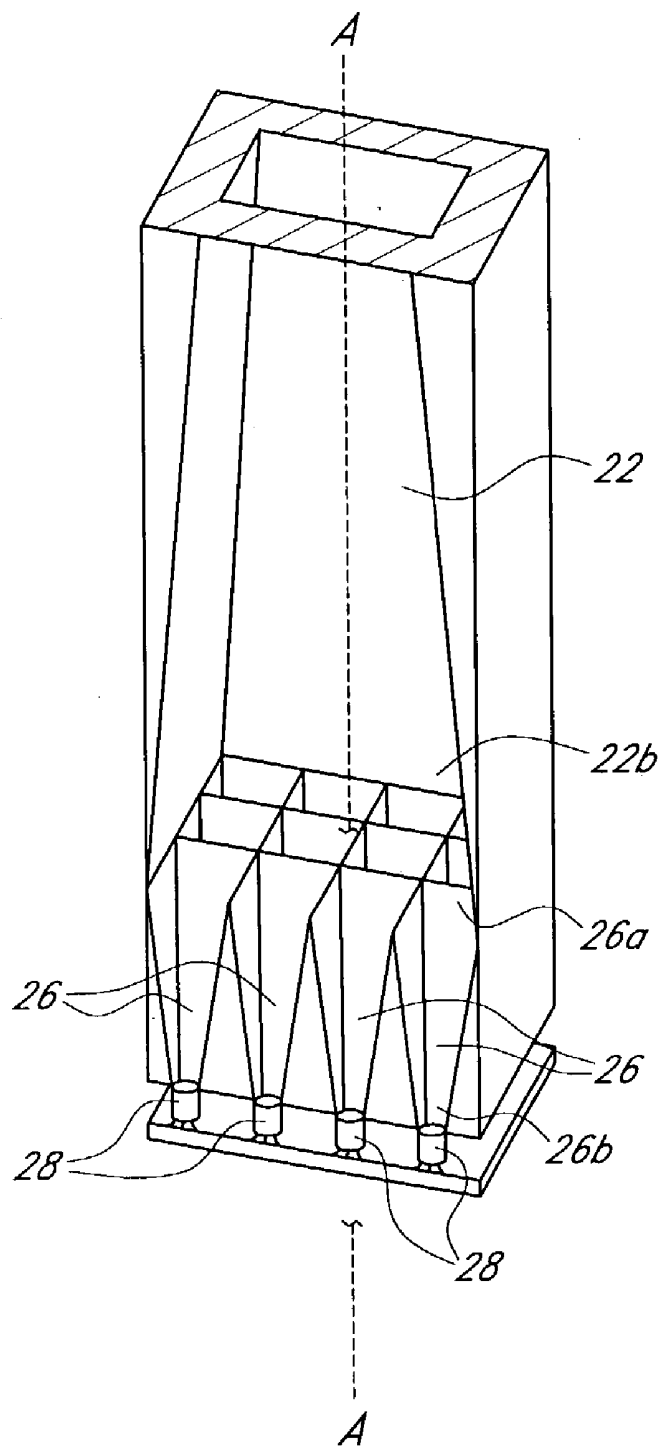
*FIG. 4*



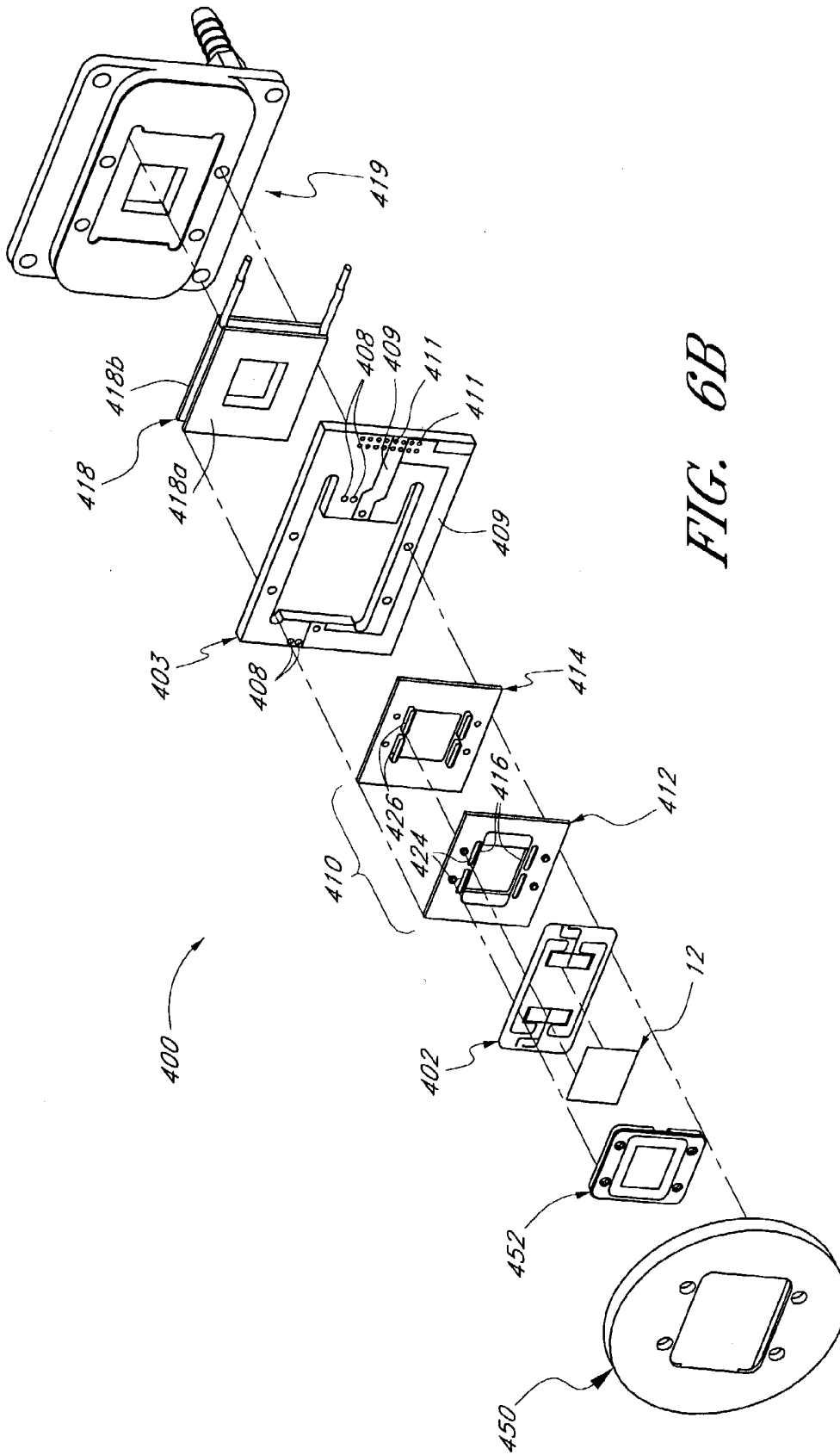
*FIG. 5*



*FIG. 6*



*FIG. 6A*



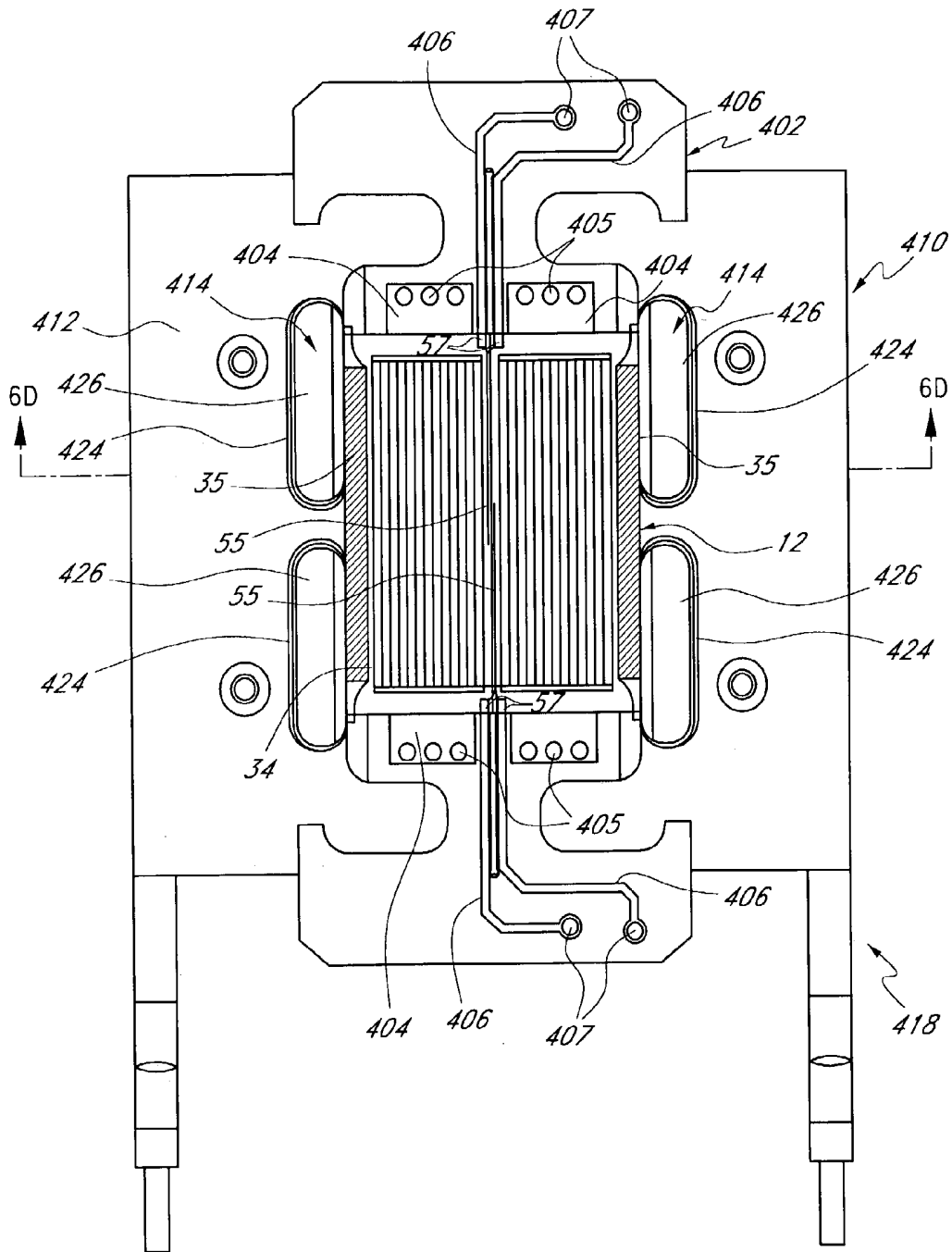
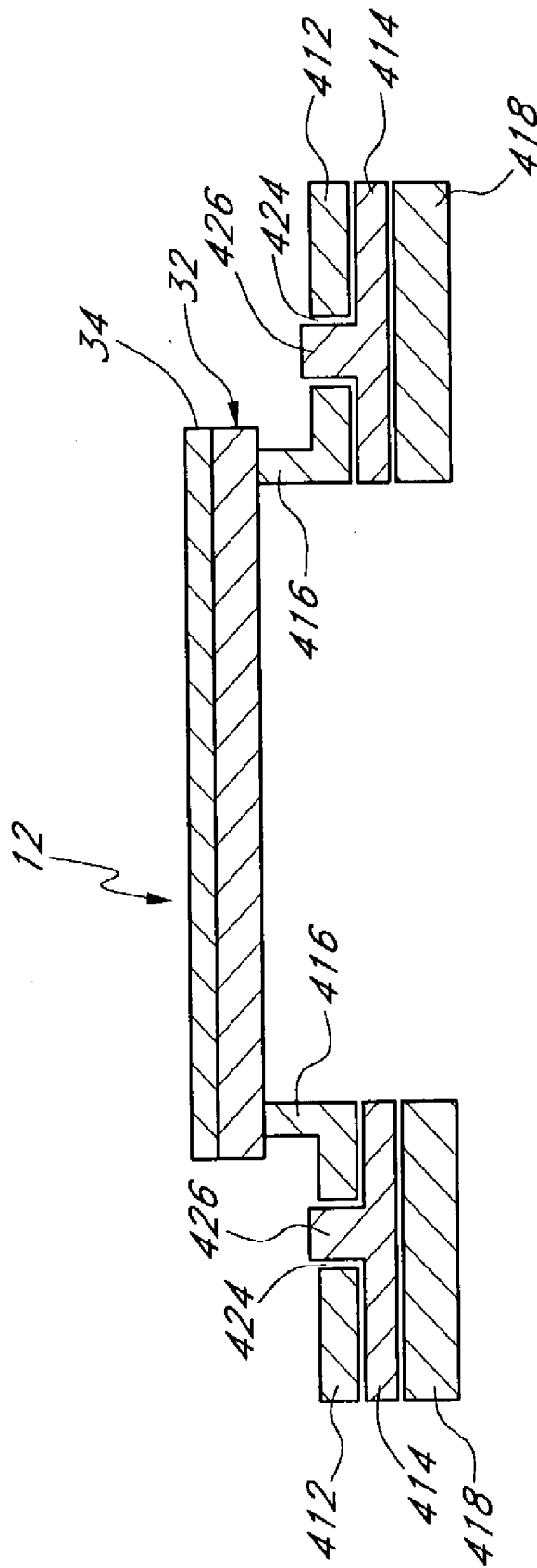


FIG. 6C



*FIG. 6D*

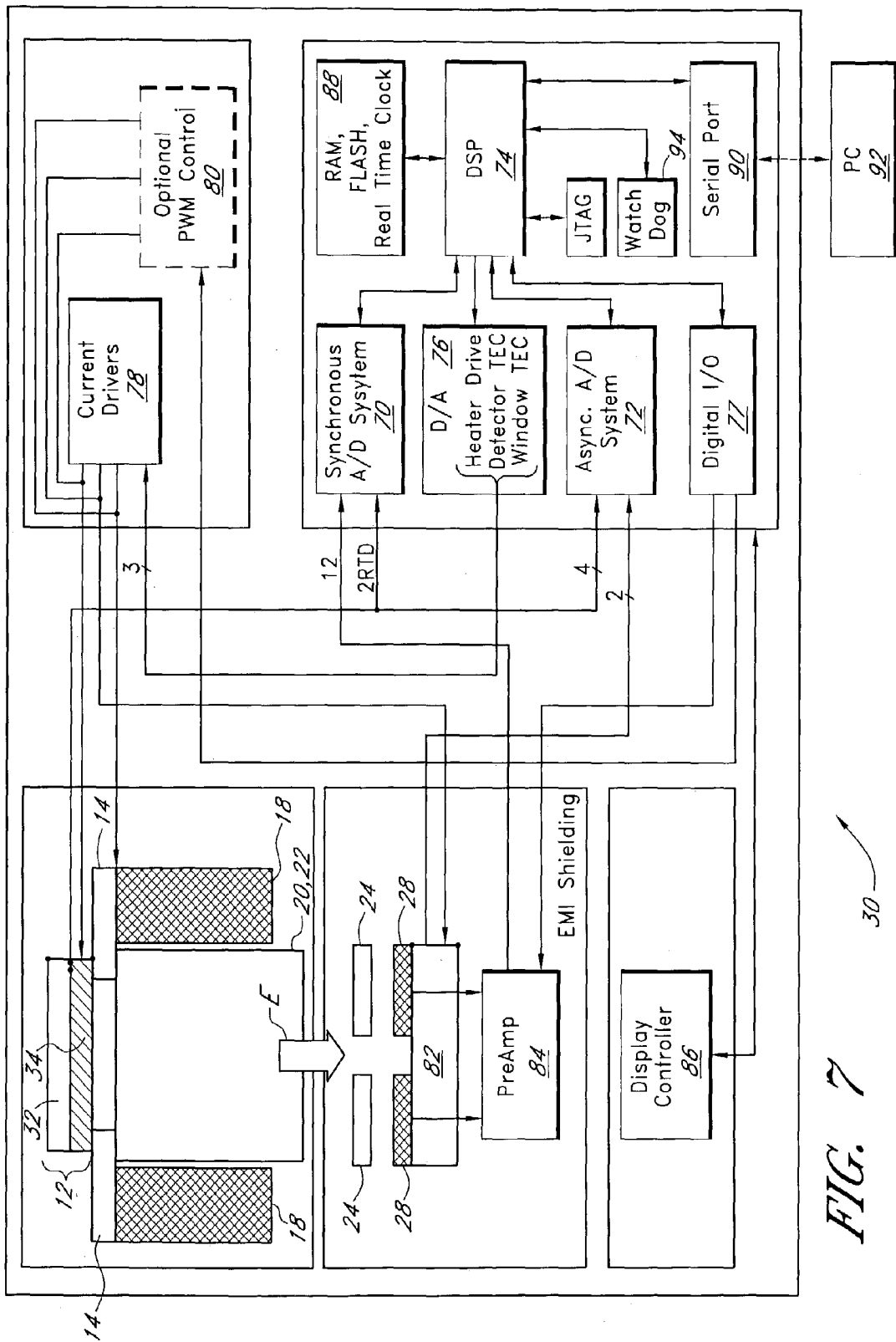
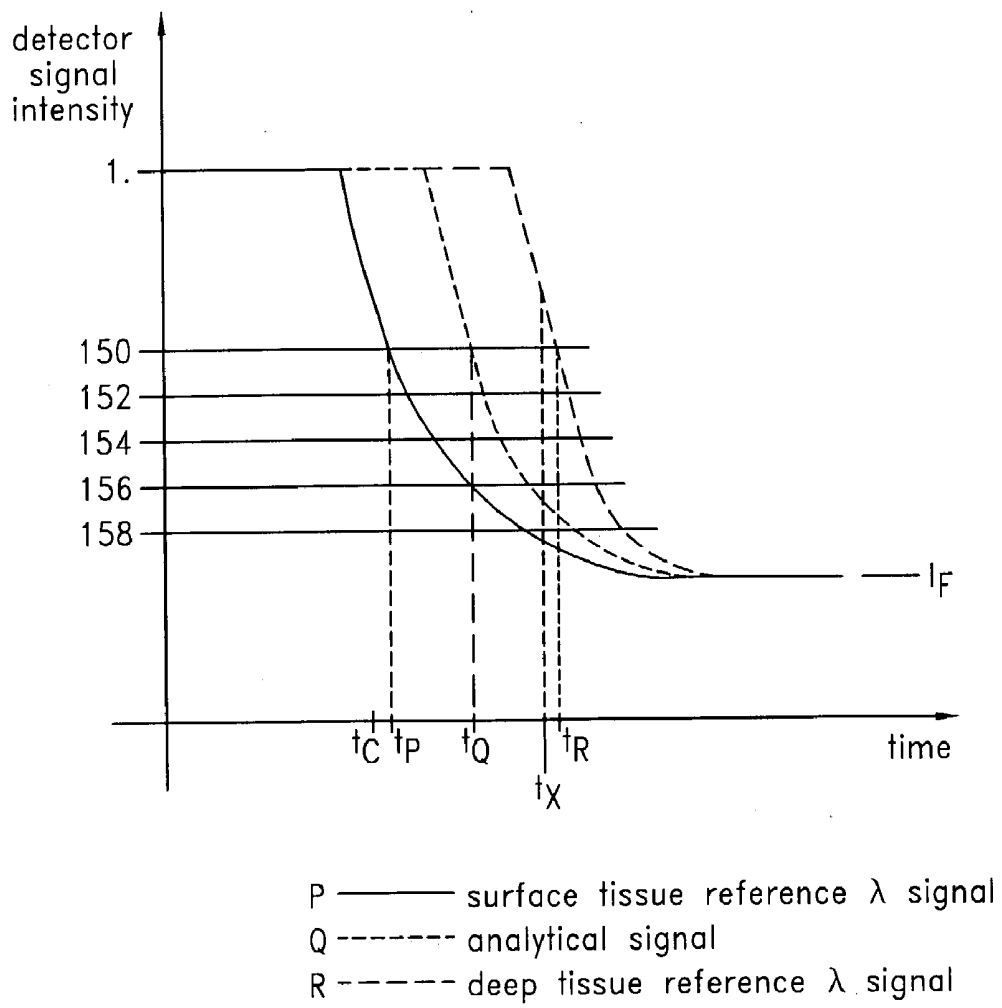
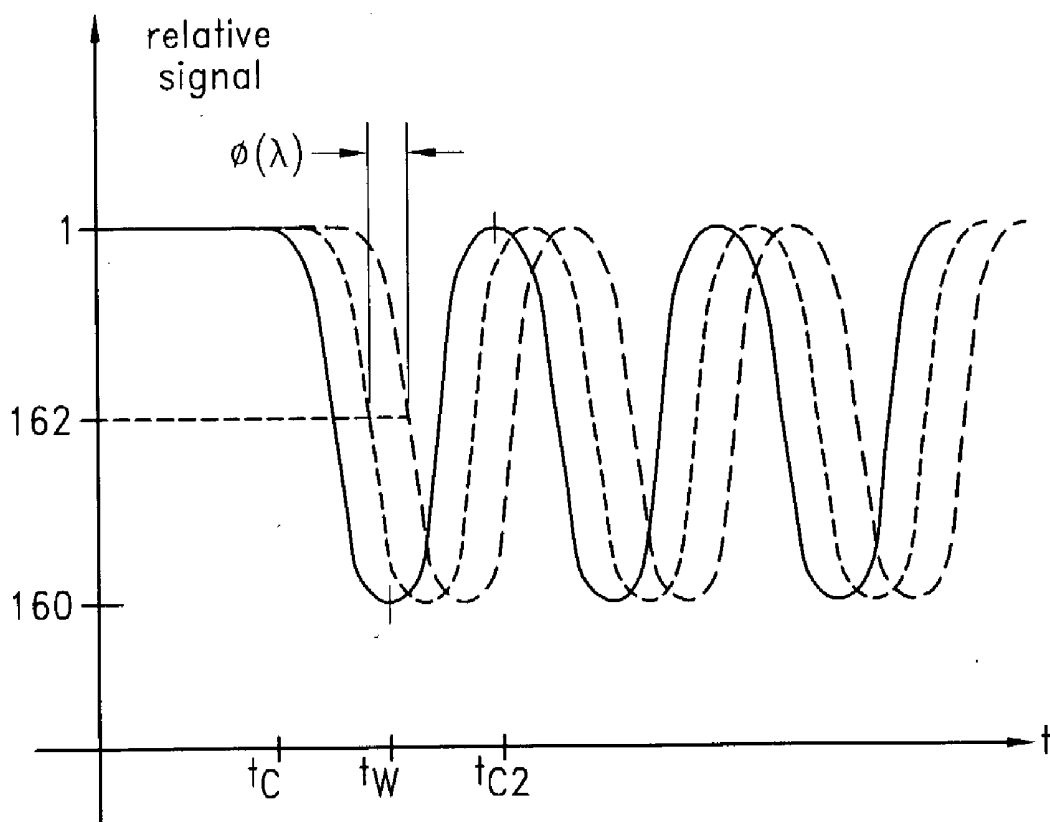


FIG. 7

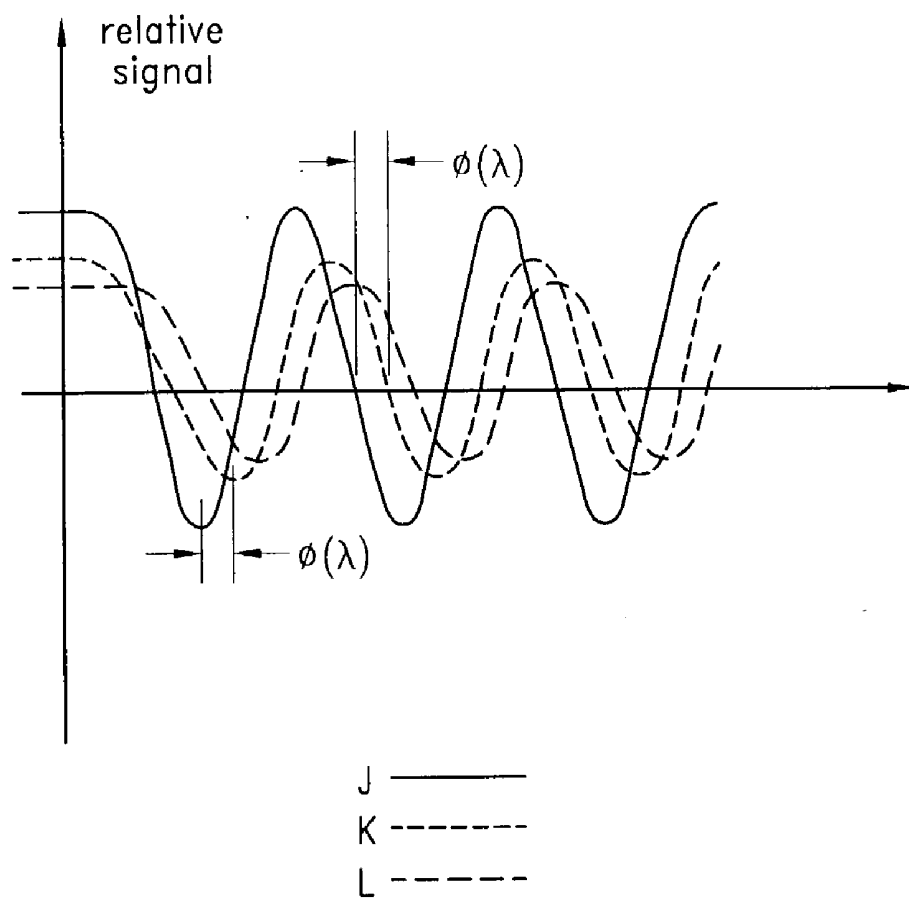


*FIG. 8*

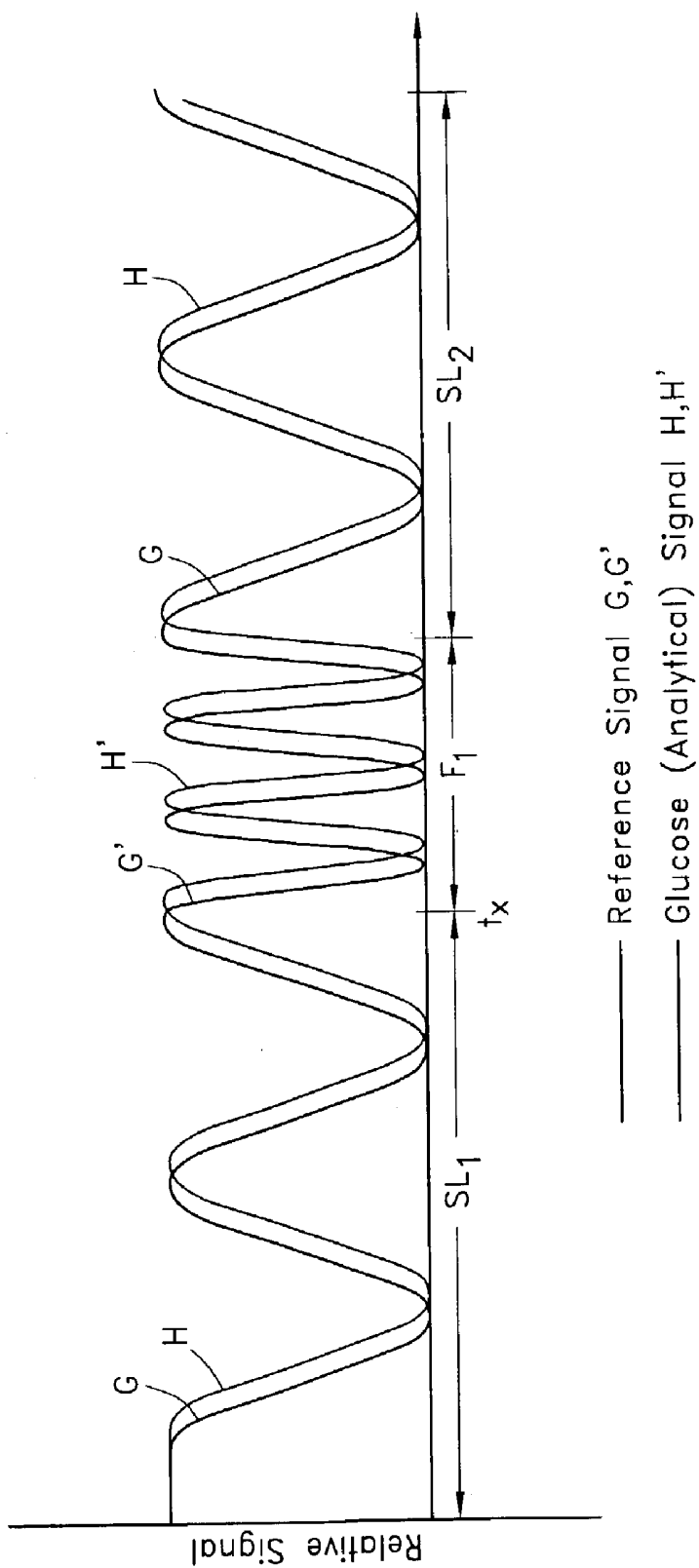


J ——— surface tissue reference signal  
K - - - - - analytical signal  
L - · - · - deep tissue reference signal

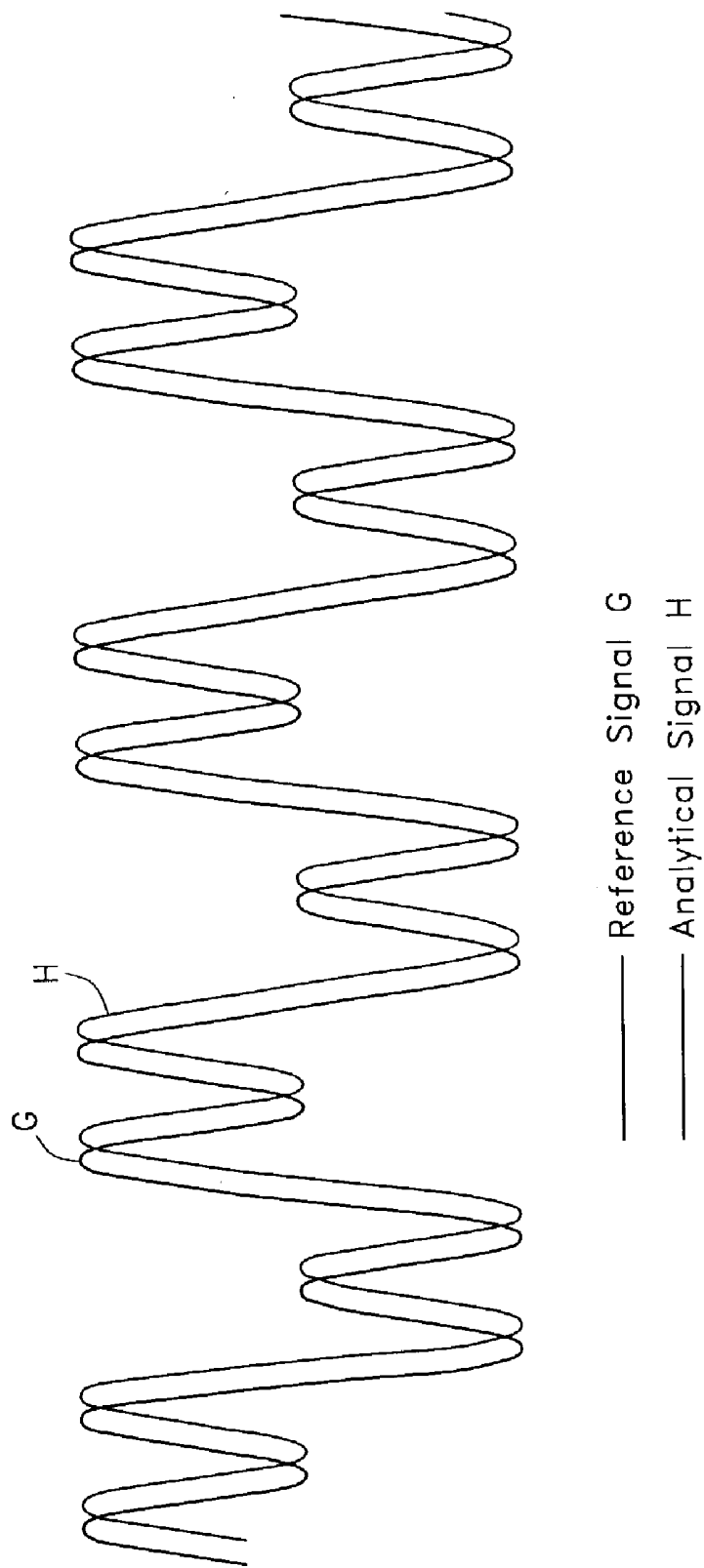
*FIG. 9*



*FIG. 10*



*FIG. 11*



*FIG. 12*

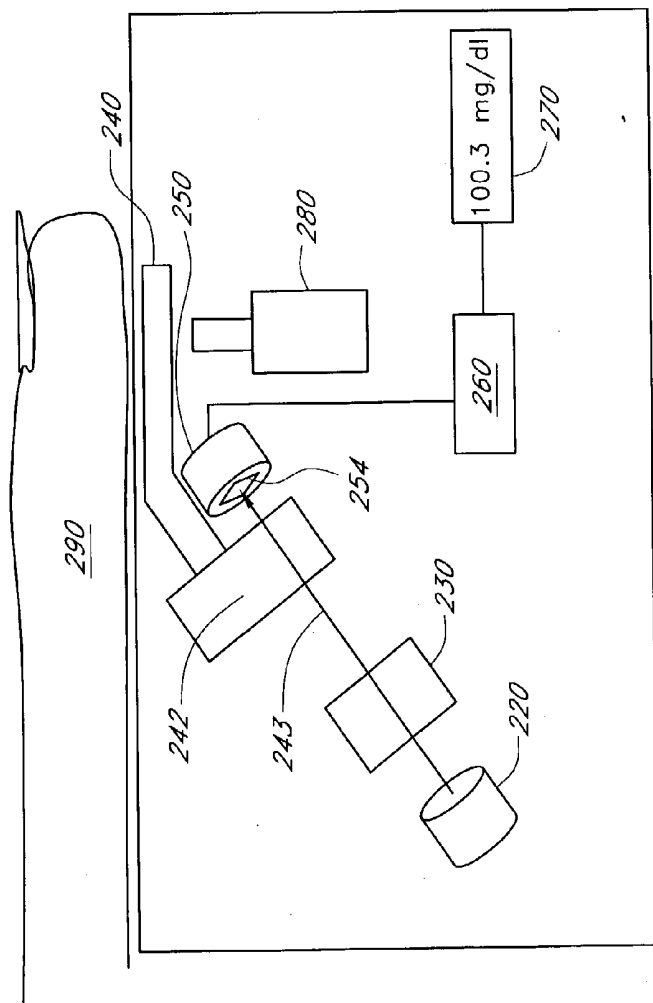


FIG. 13

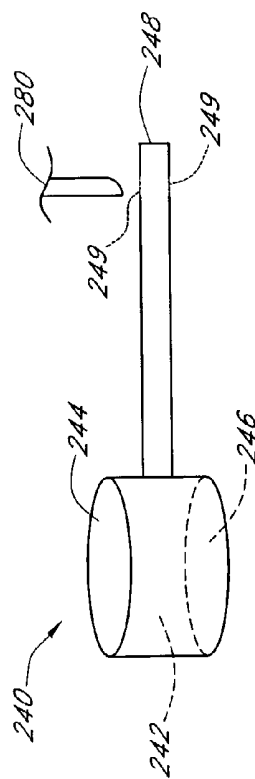


FIG. 14

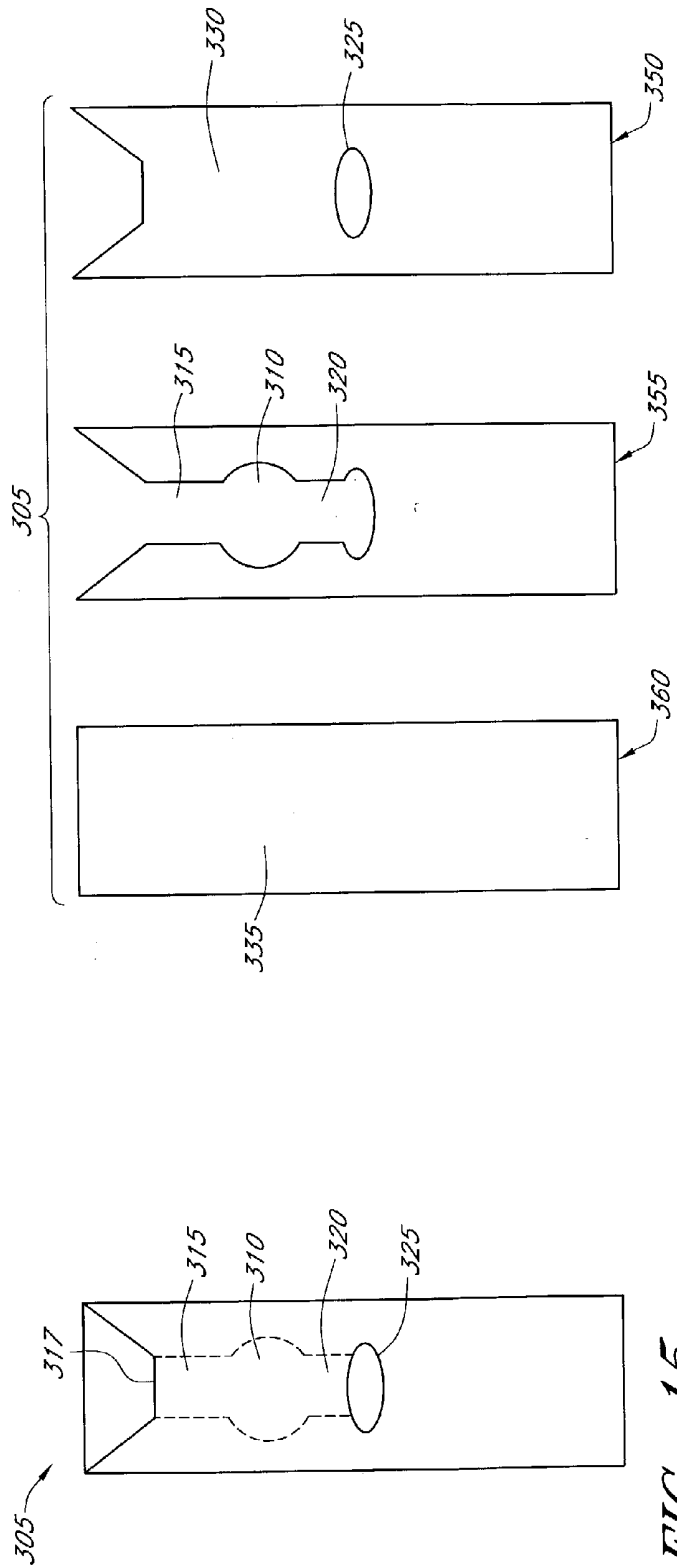


FIG. 15

FIG. 16

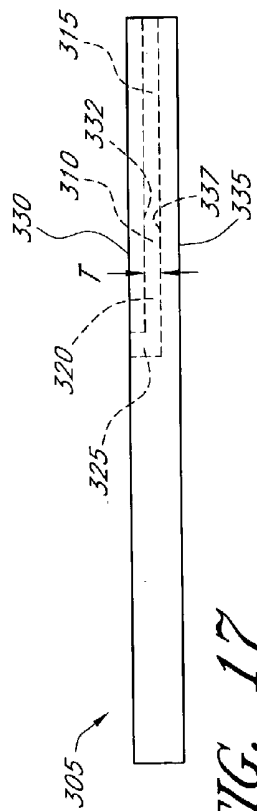


FIG. 17

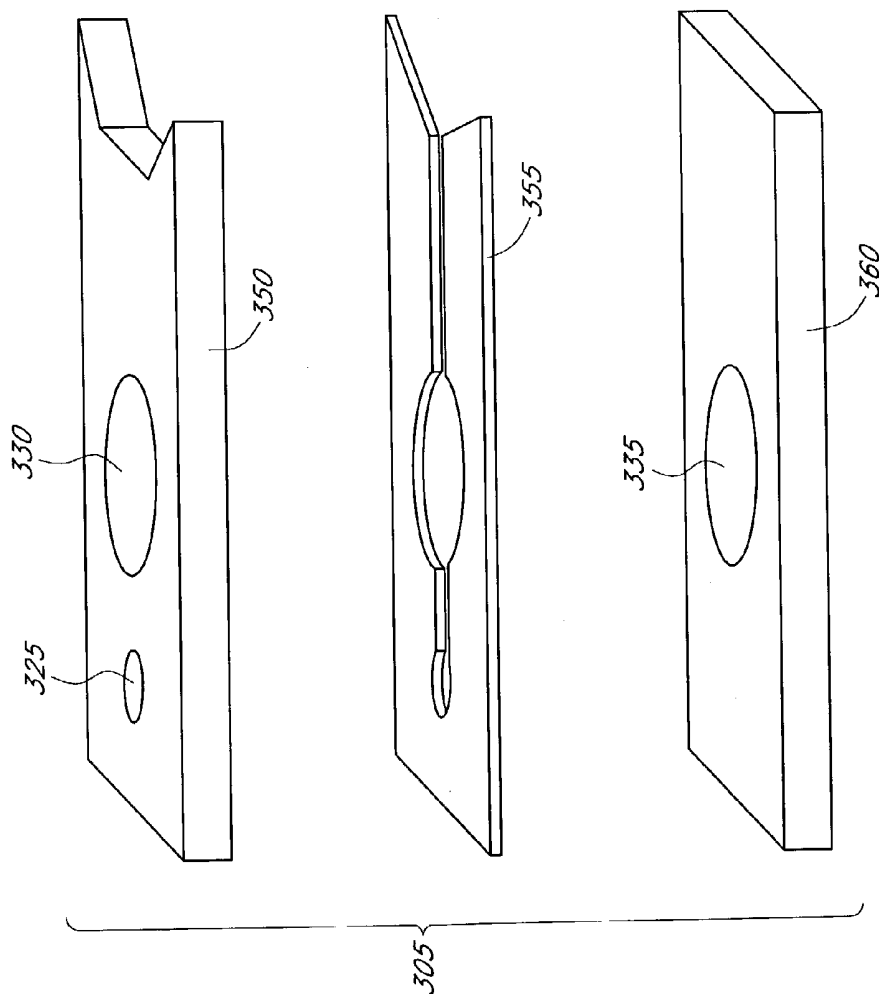
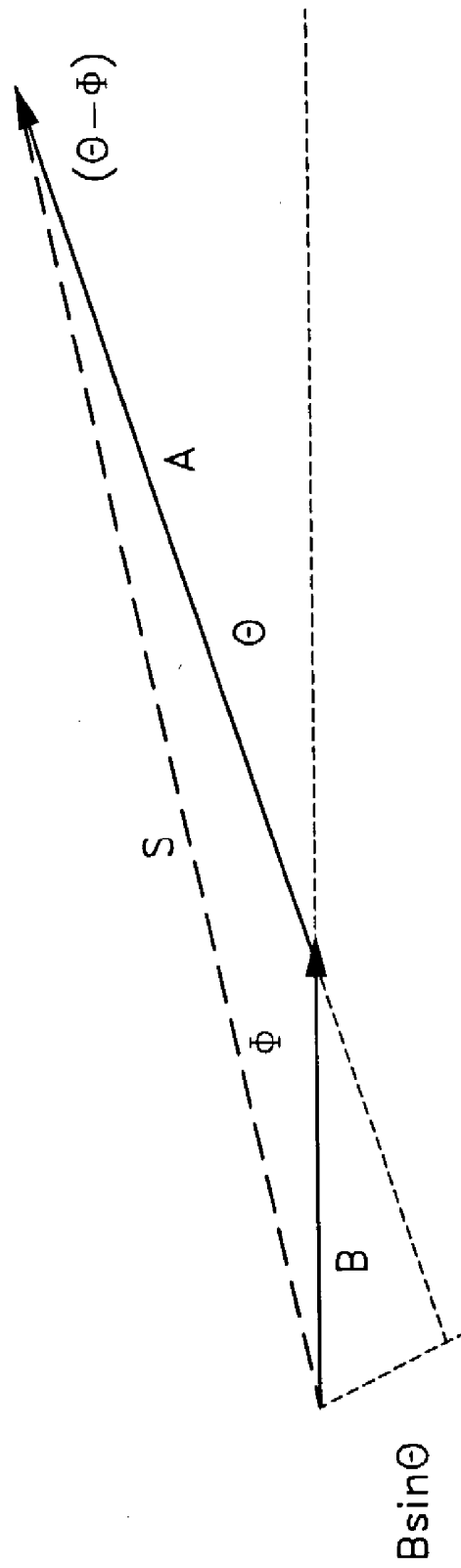
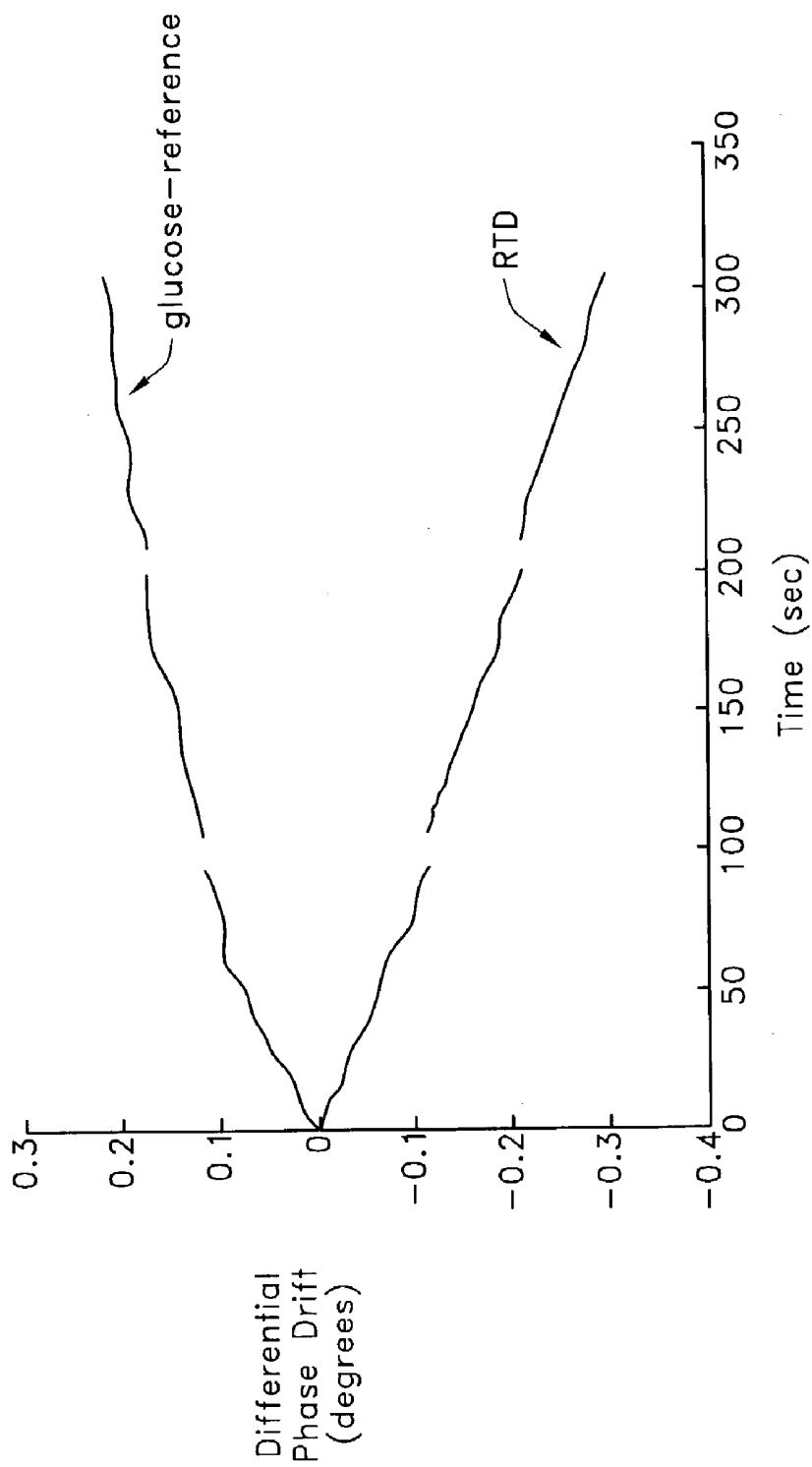


FIG. 16A



*FIG. 18*



*FIG. 19*

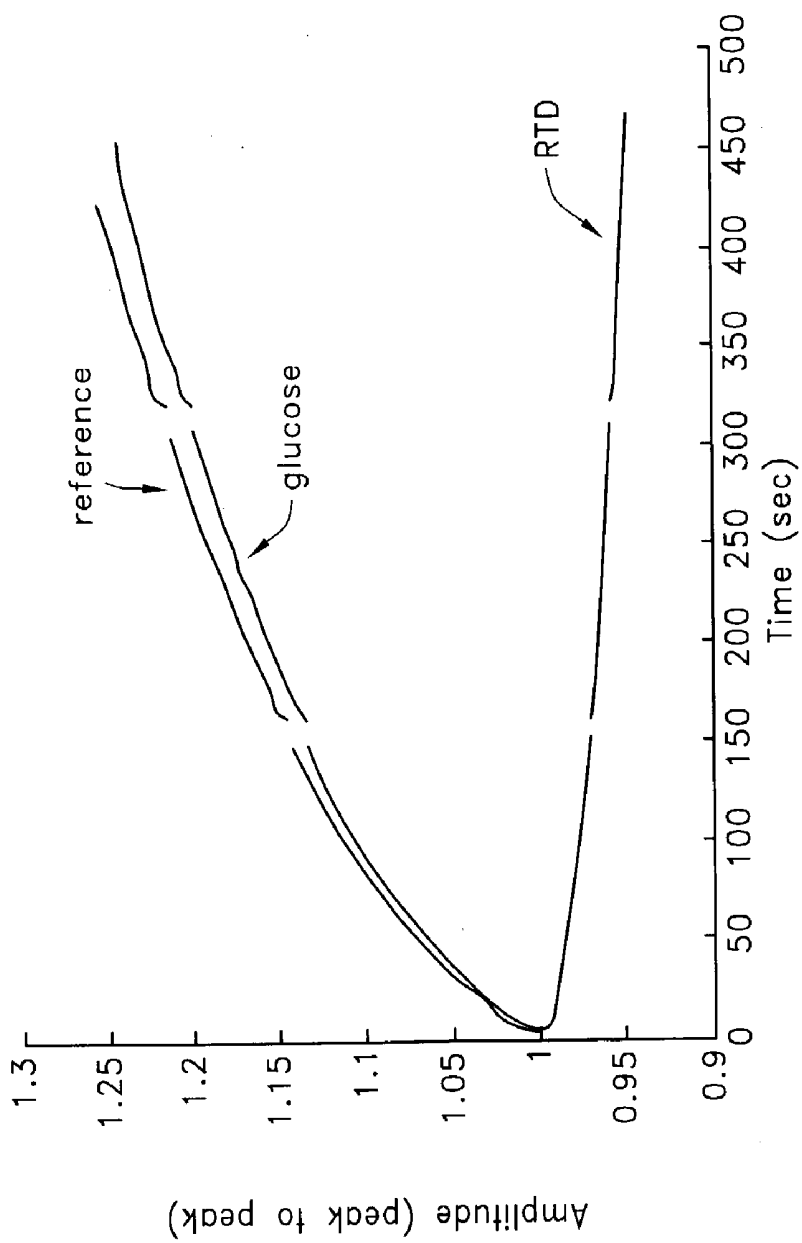
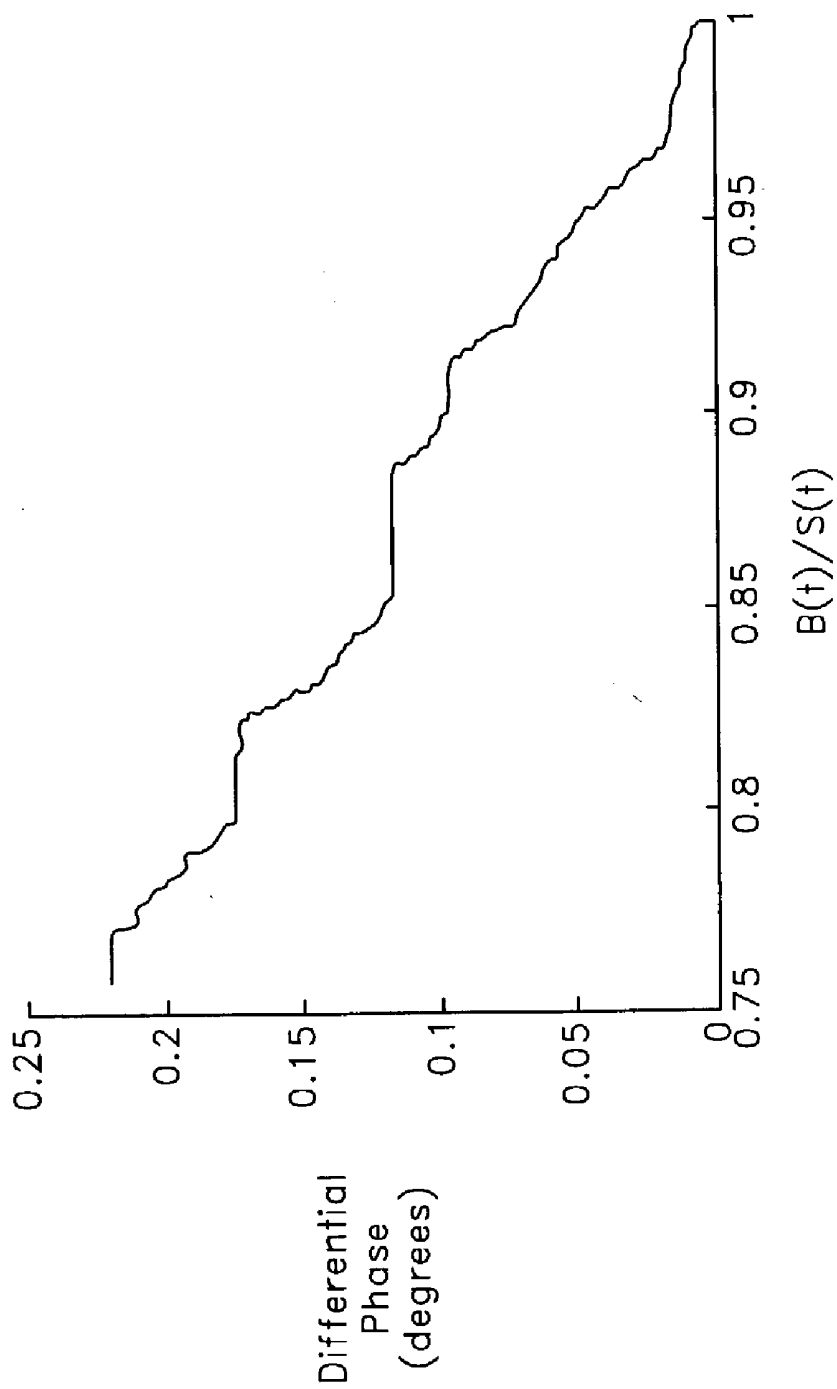
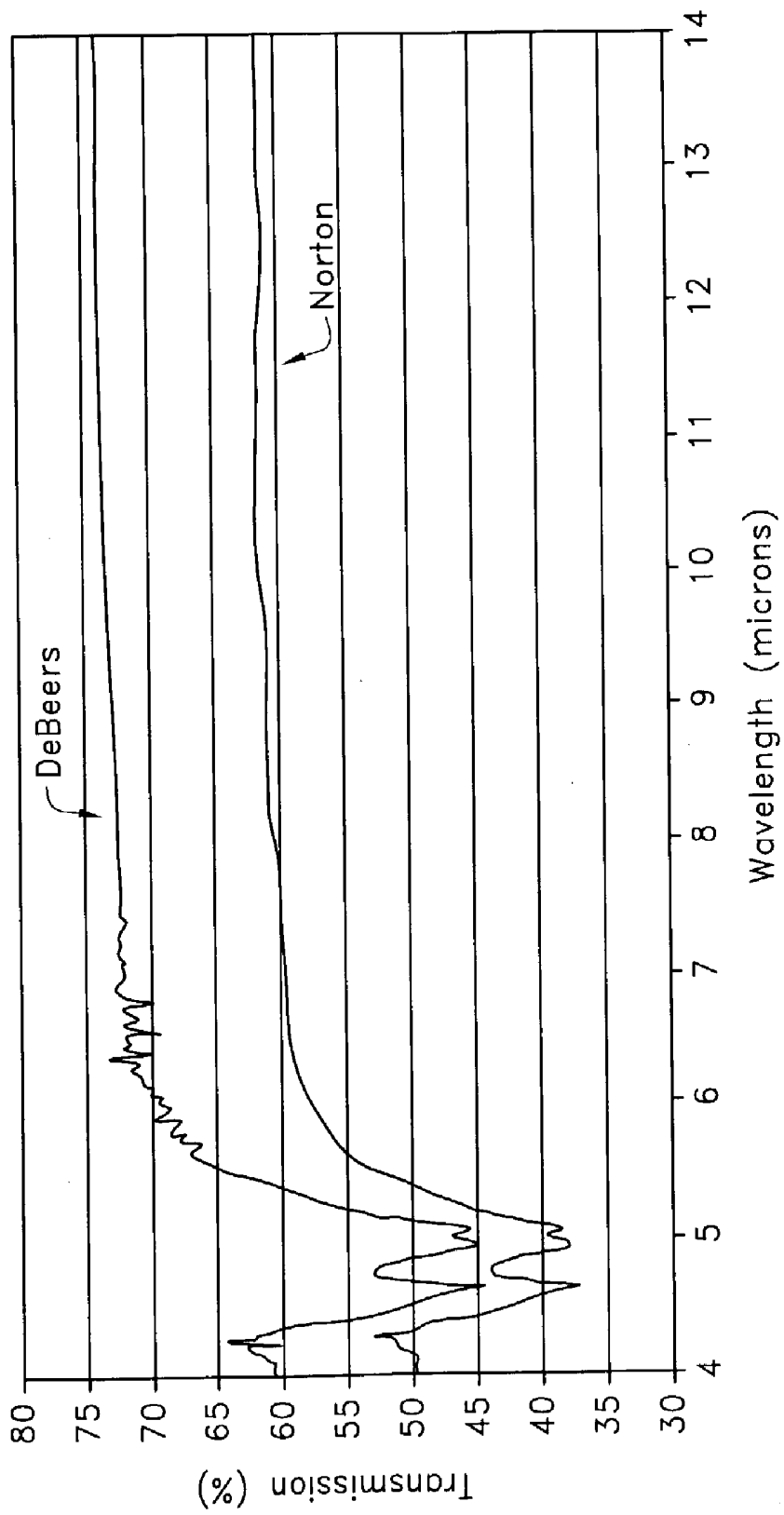


FIG. 20



*FIG. 21*



*FIG. 22*

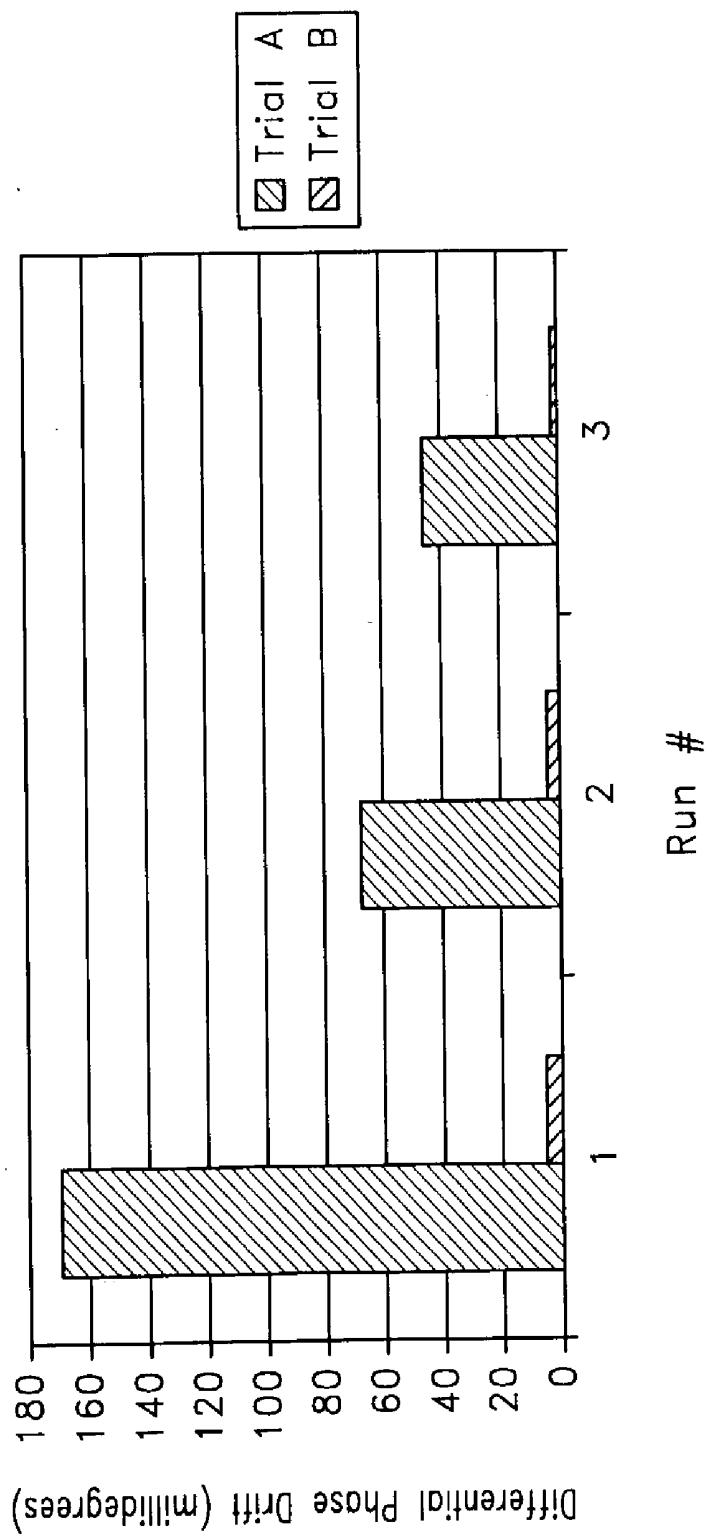


FIG. 23

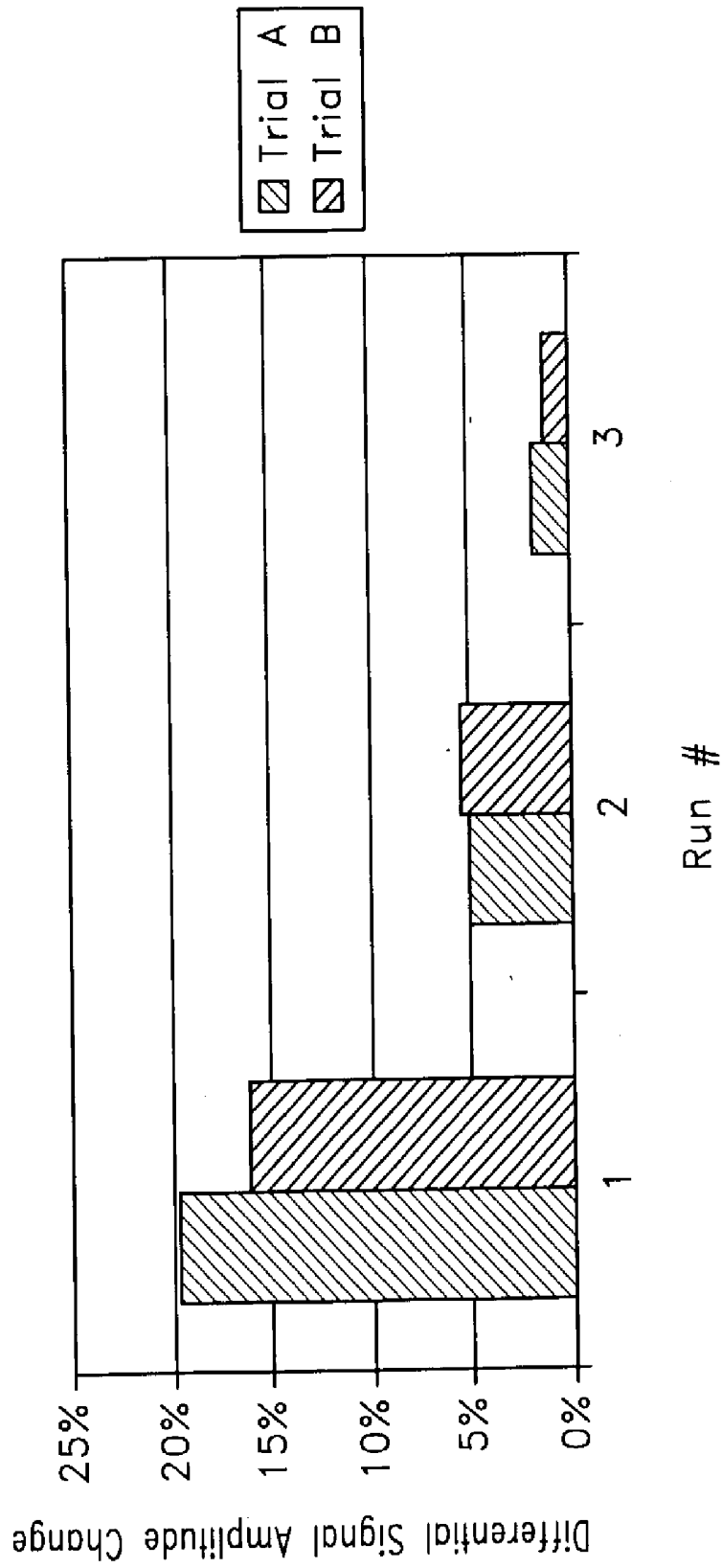
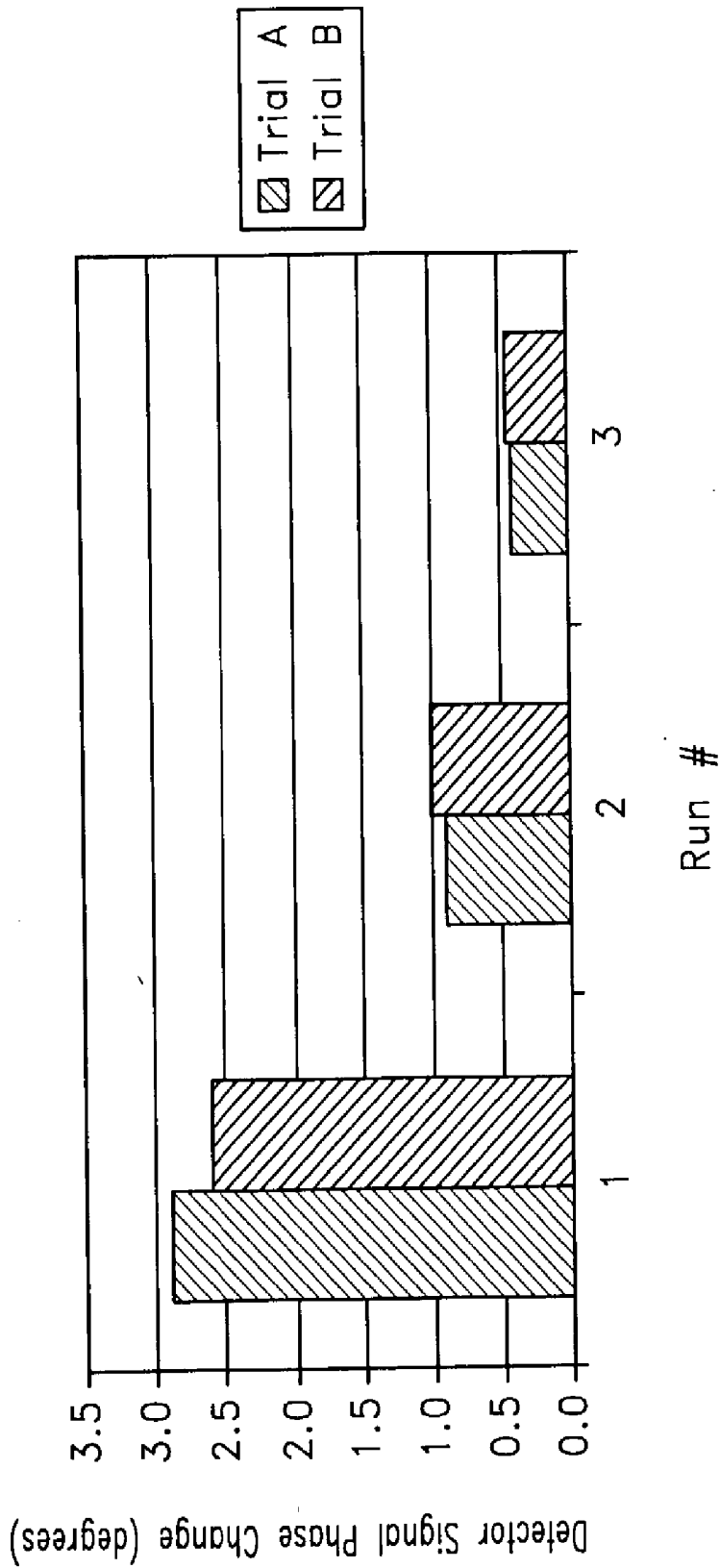
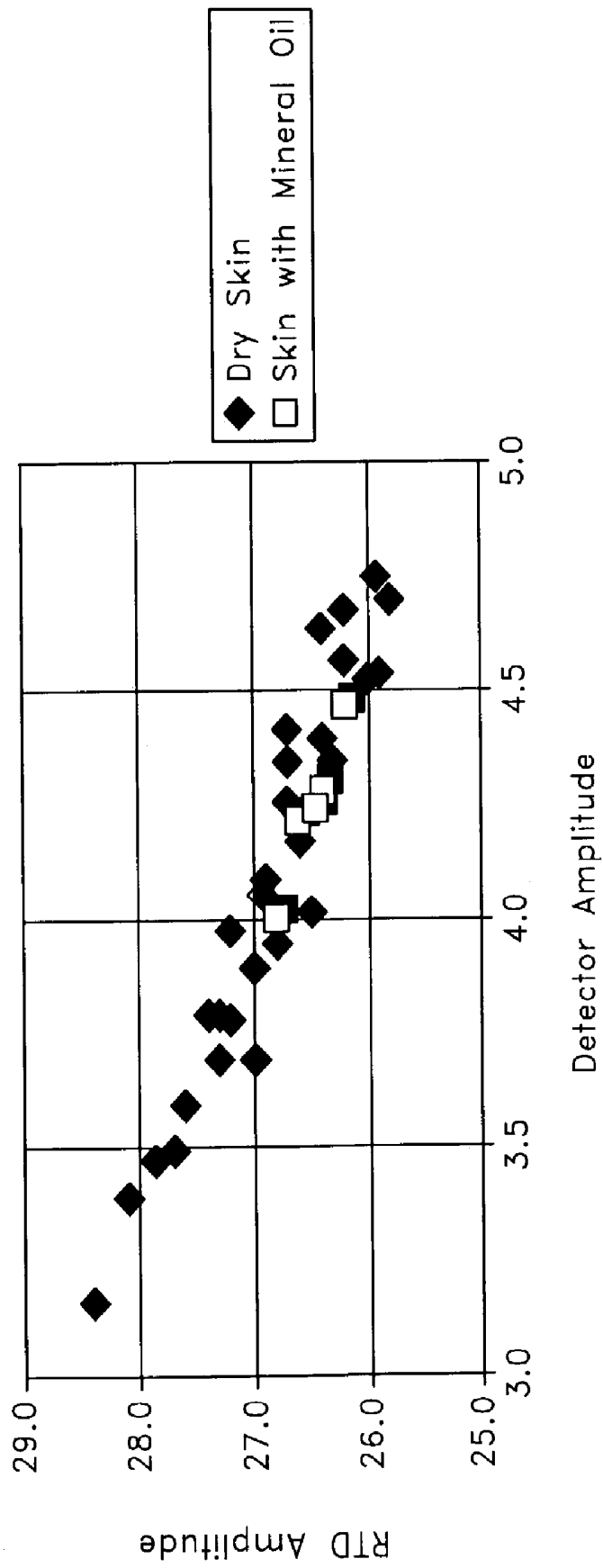


FIG. 24



*FIG. 25*



*FIG. 26*

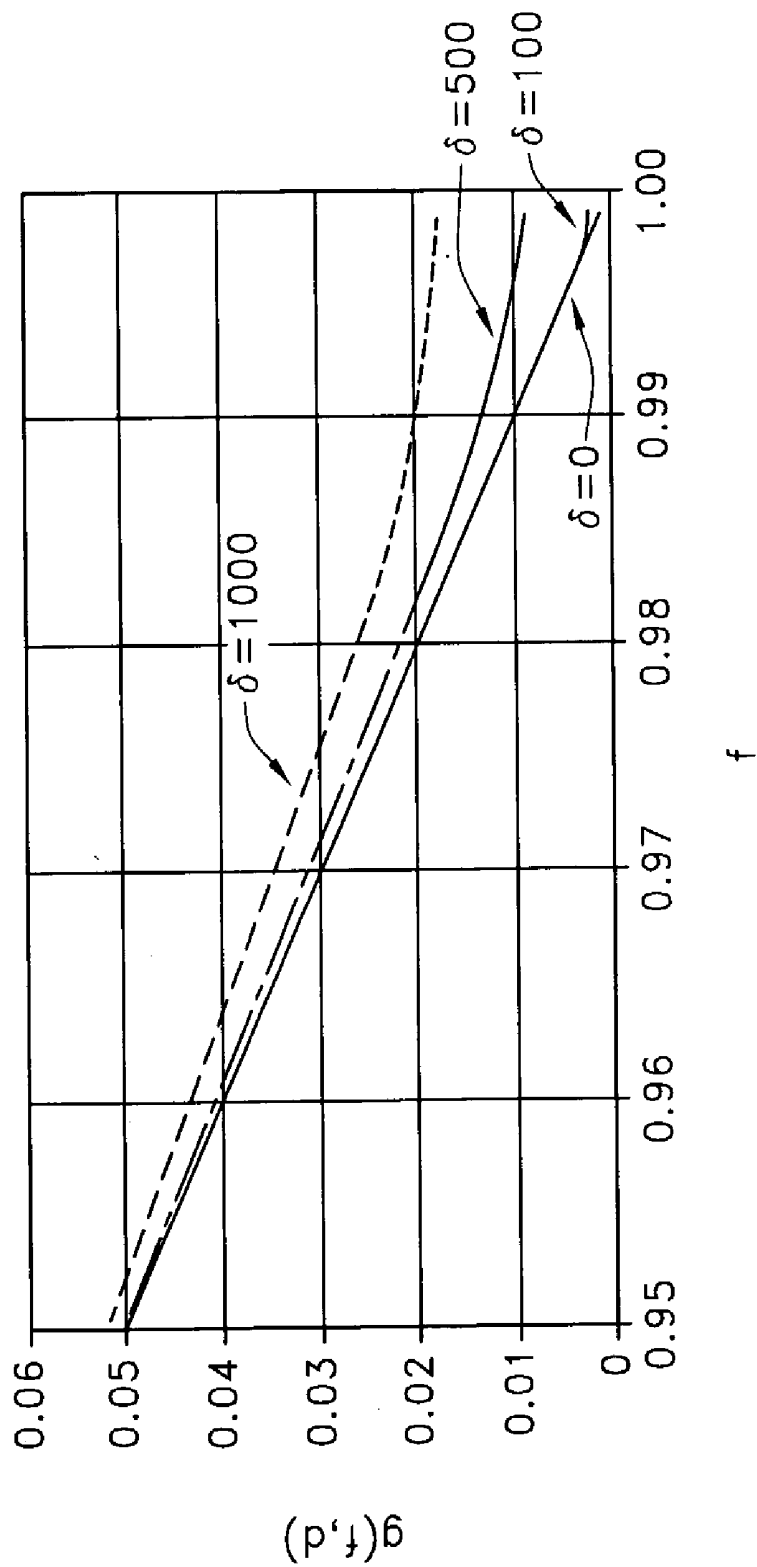
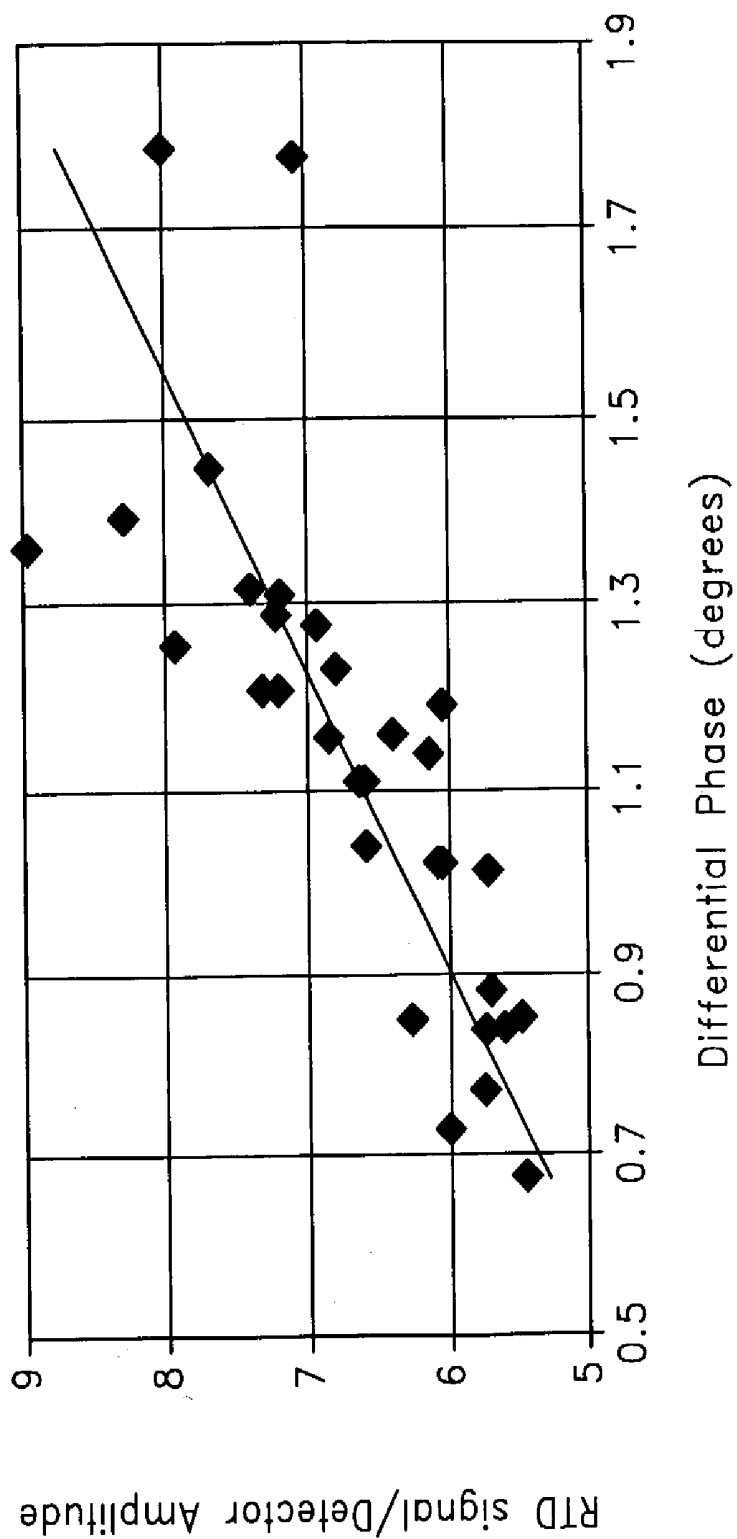
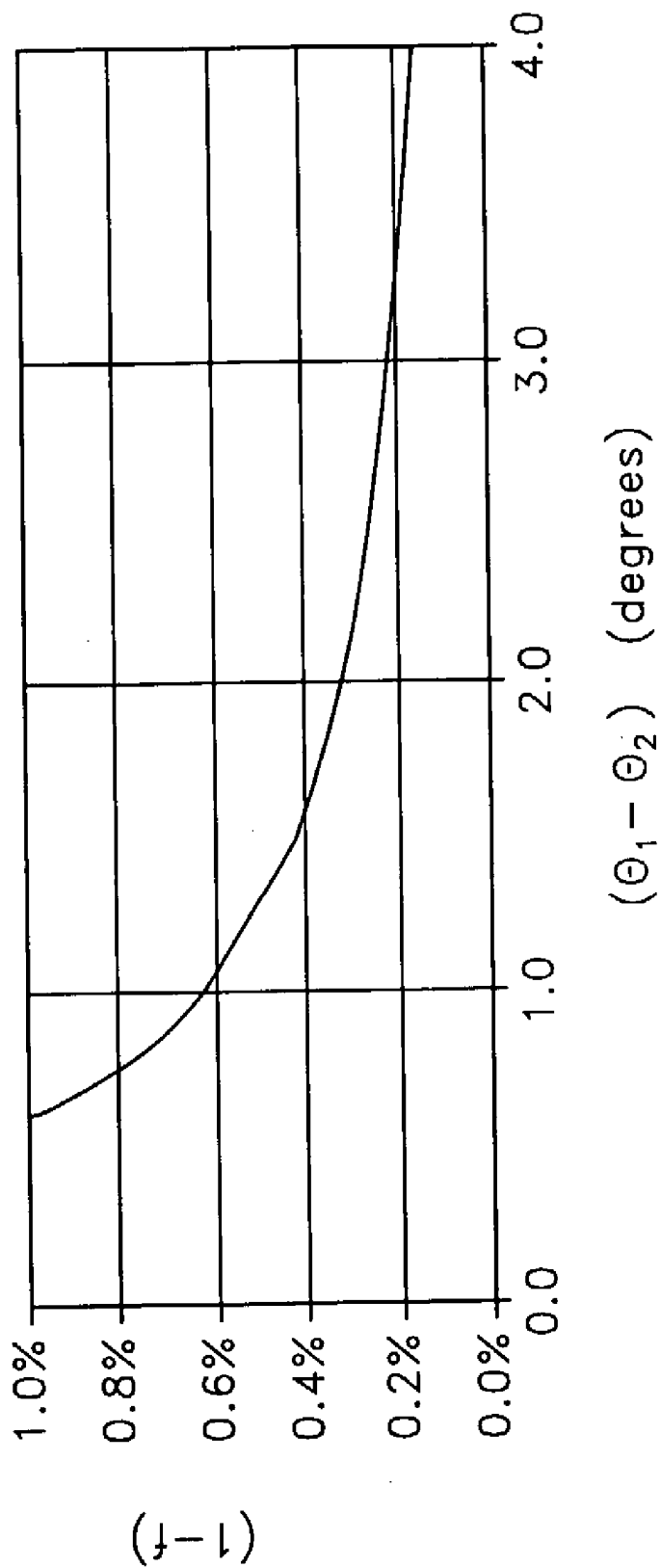


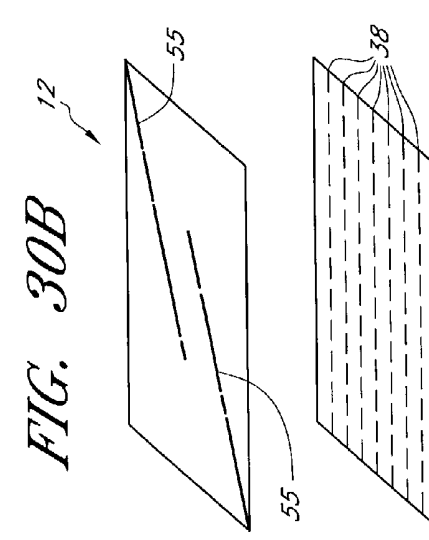
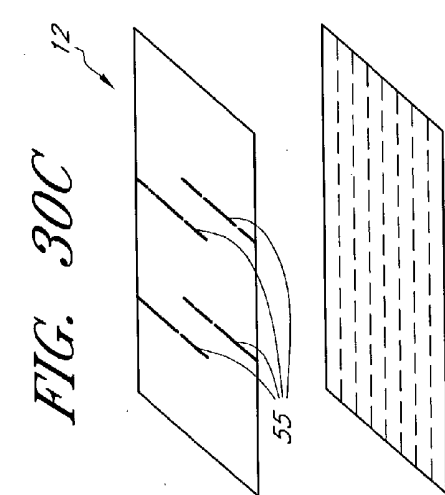
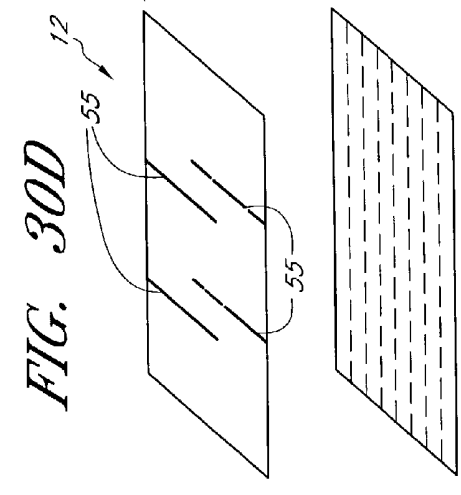
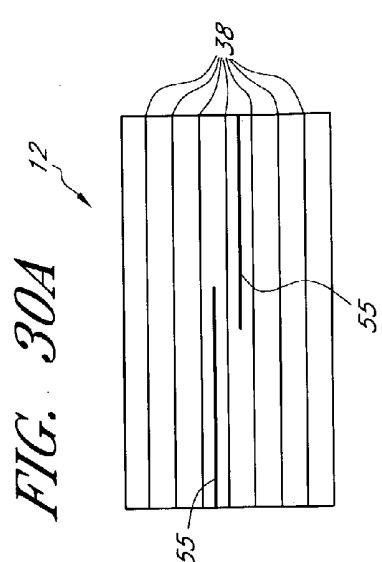
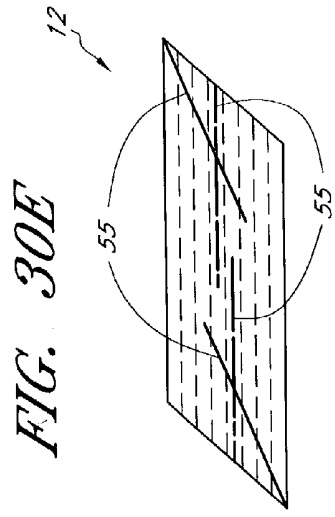
FIG. 27

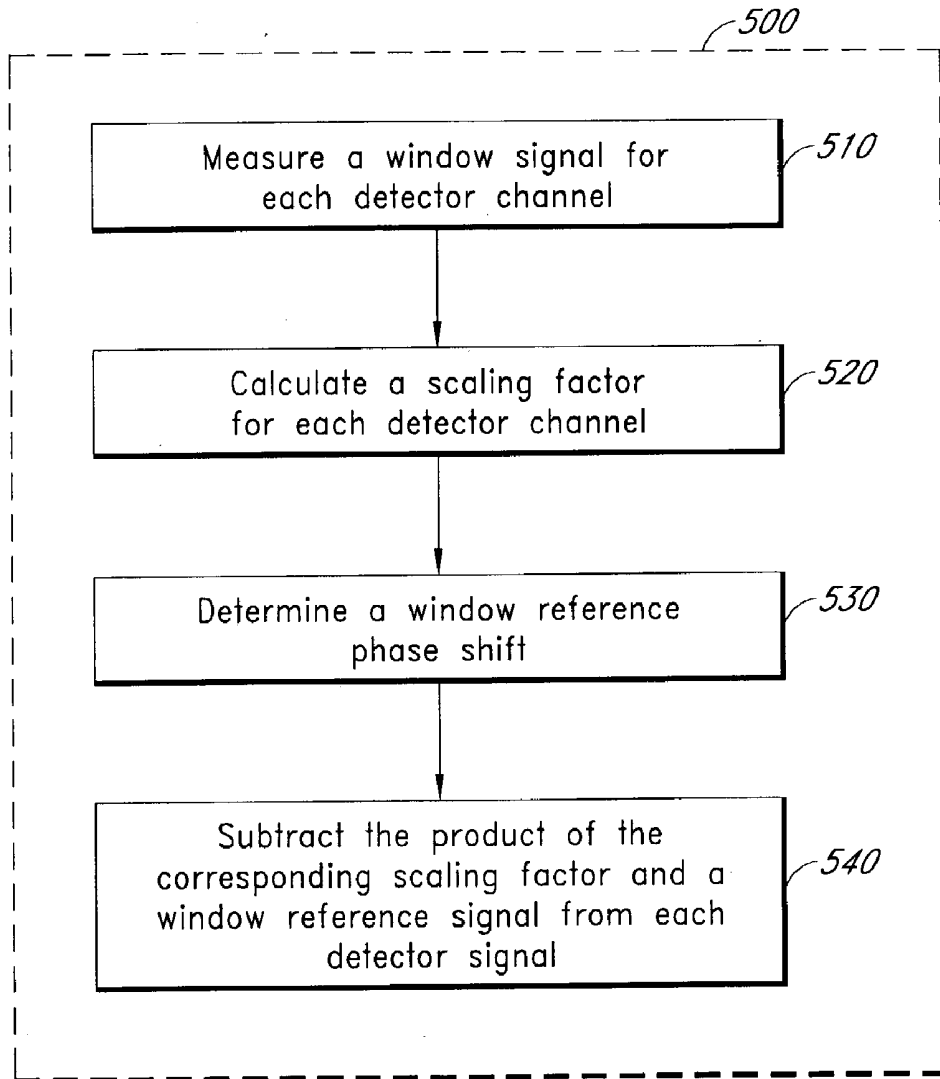


*FIG. 28*

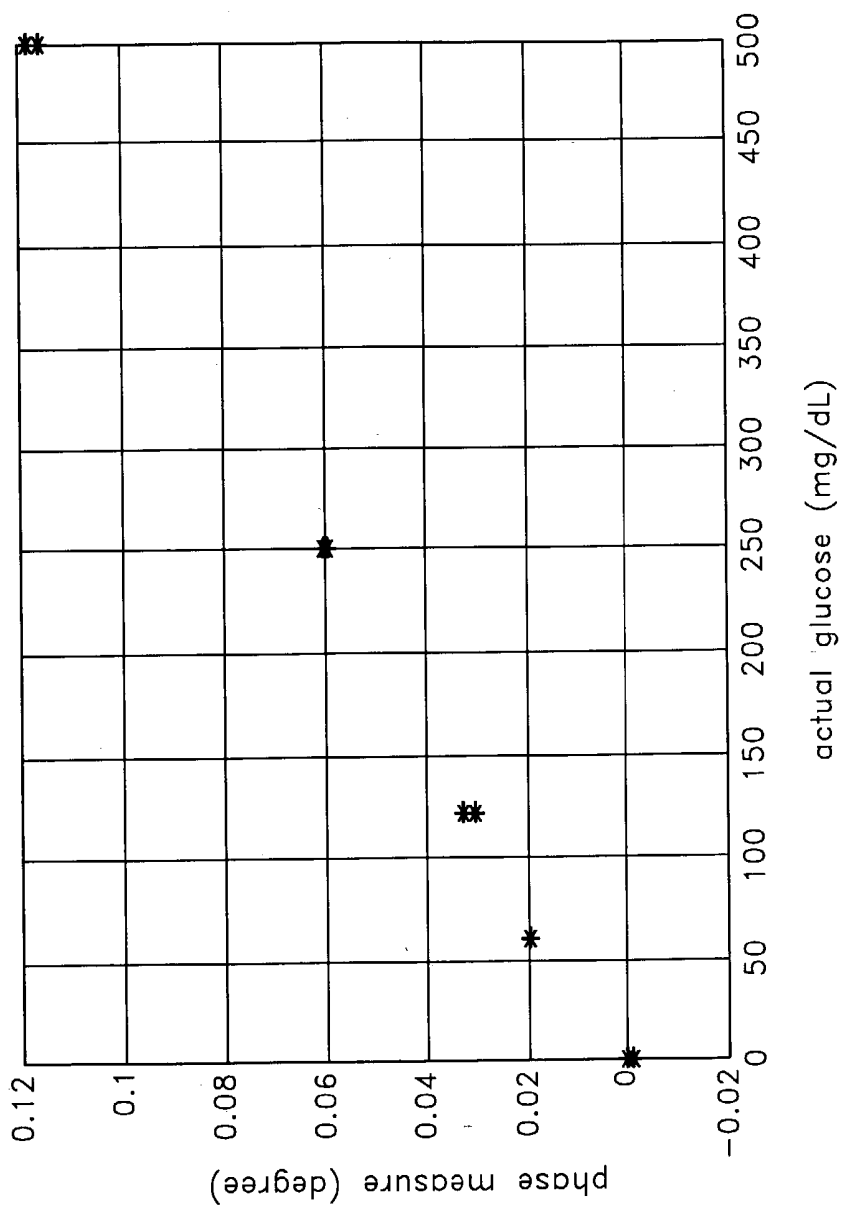


*FIG. 29*





*FIG. 31*



*FIG. 32A*

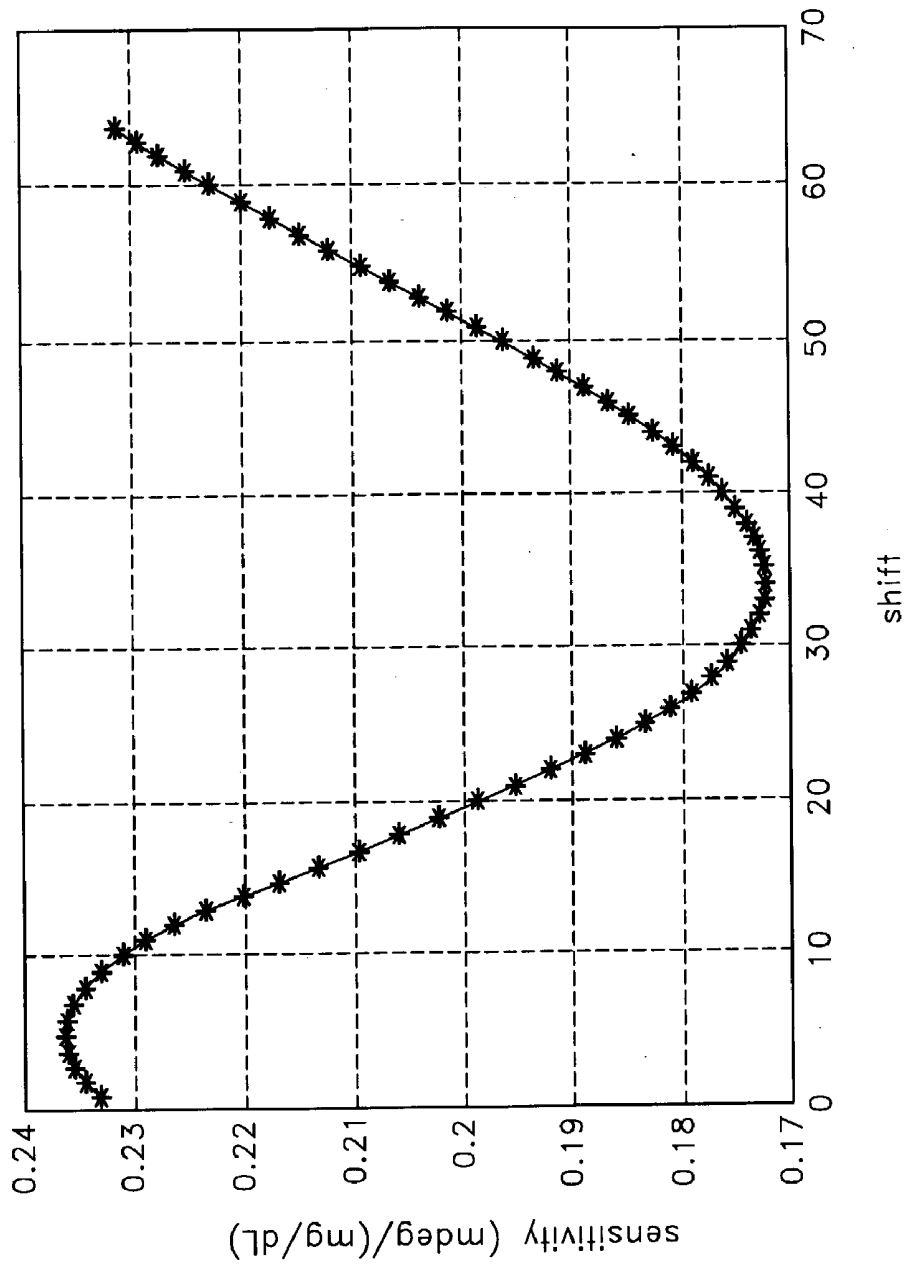
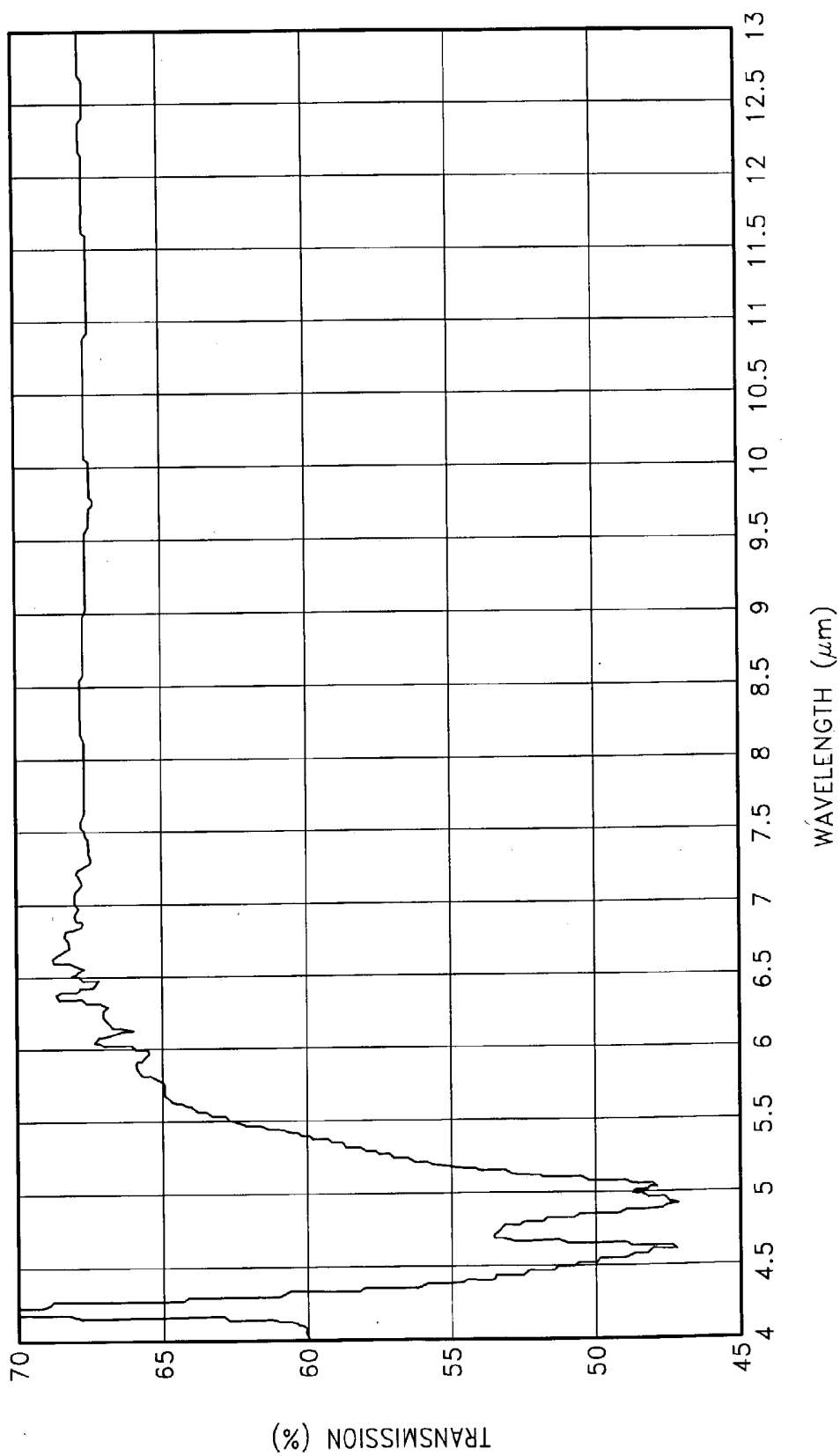
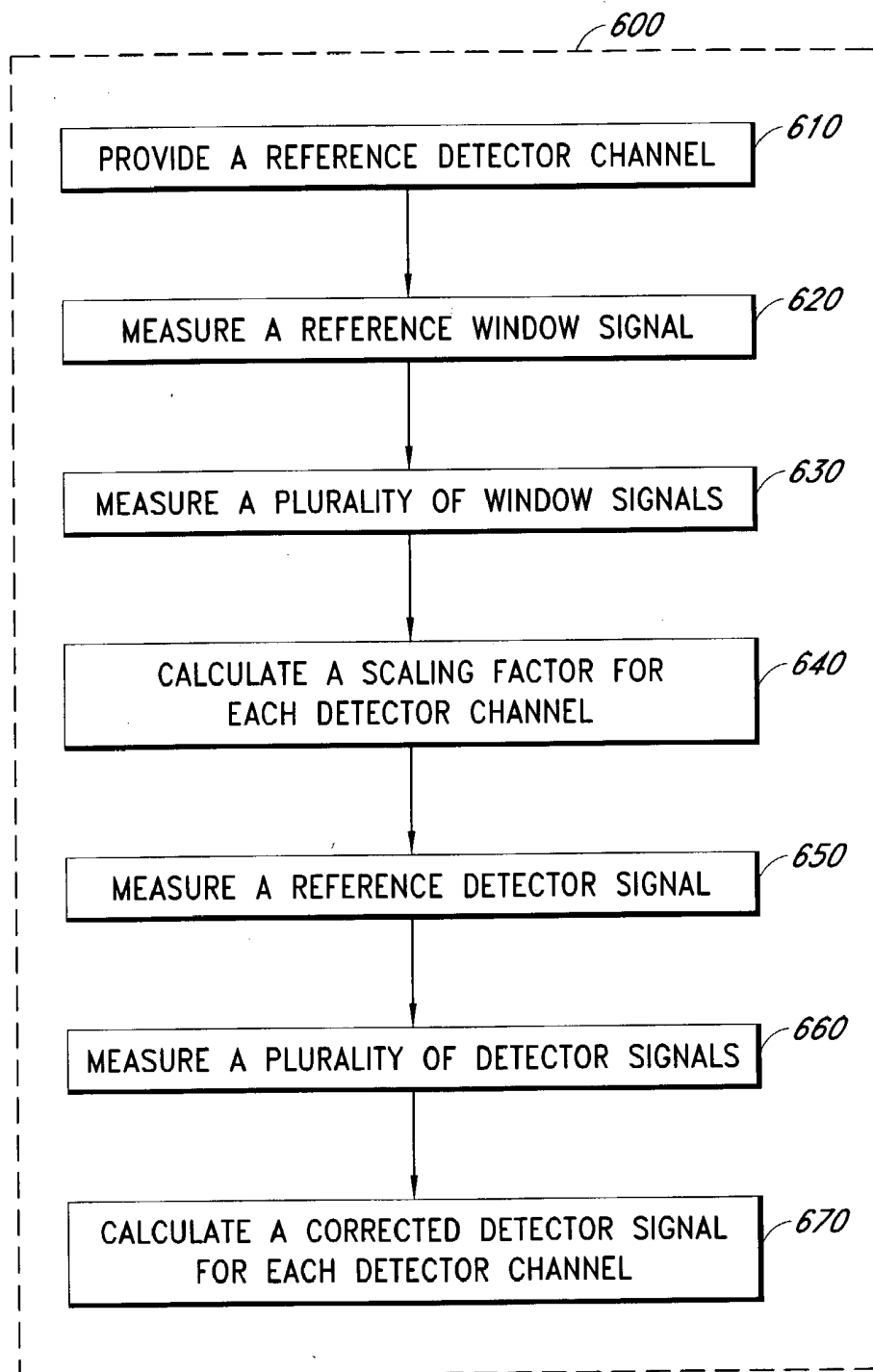


FIG. 32B



*FIG. 33*



*FIG. 34*

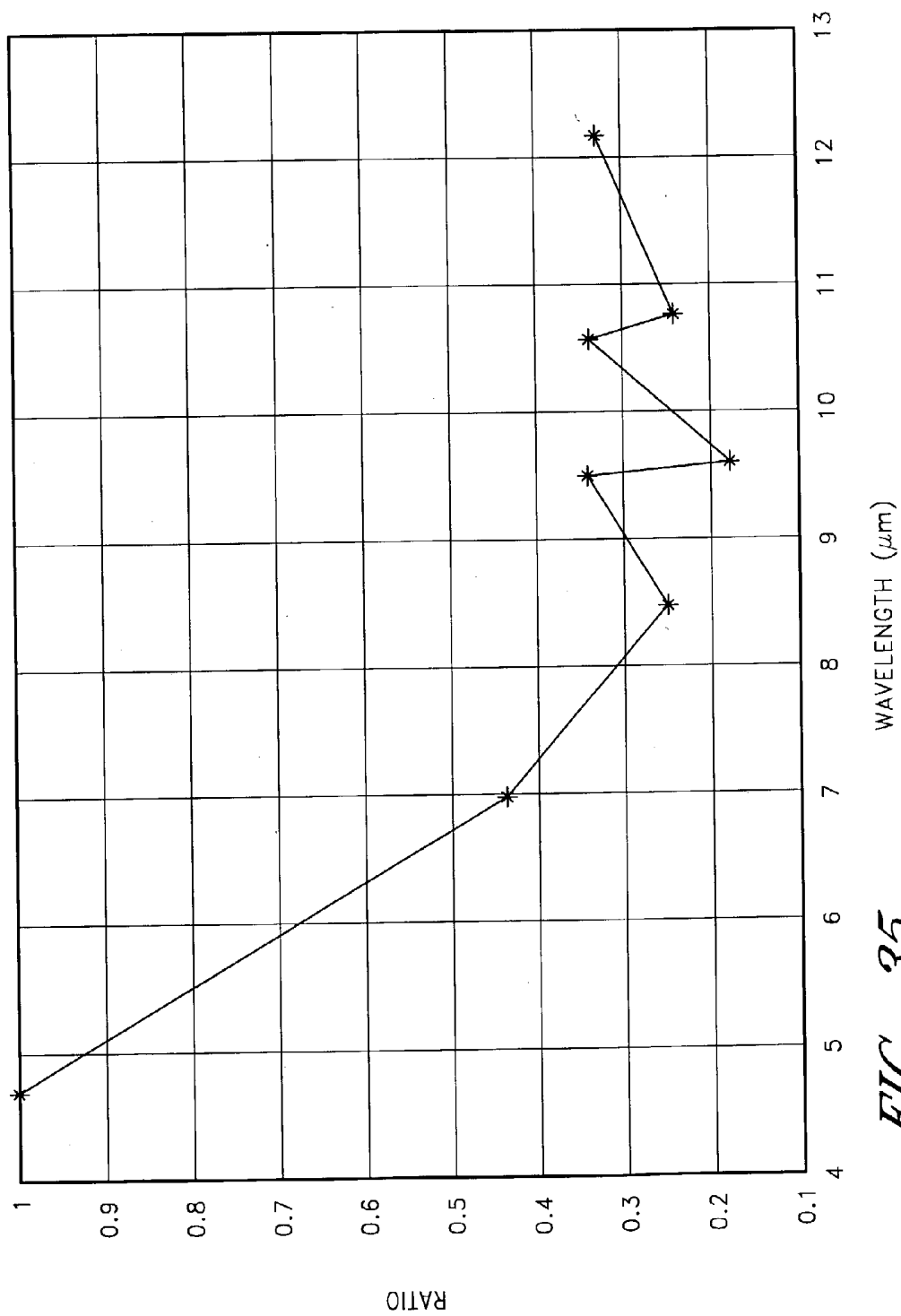


FIG. 35

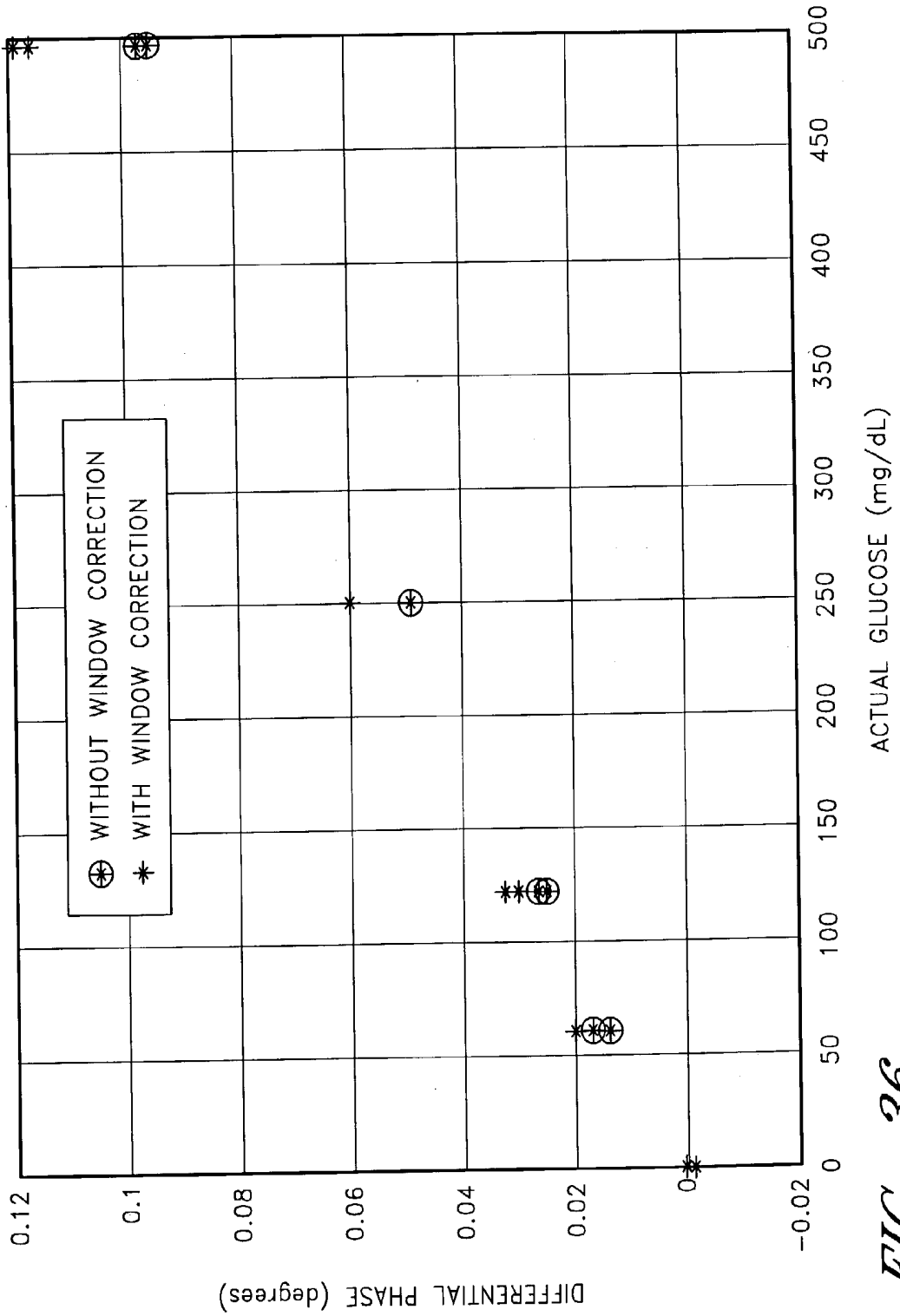


FIG. 36

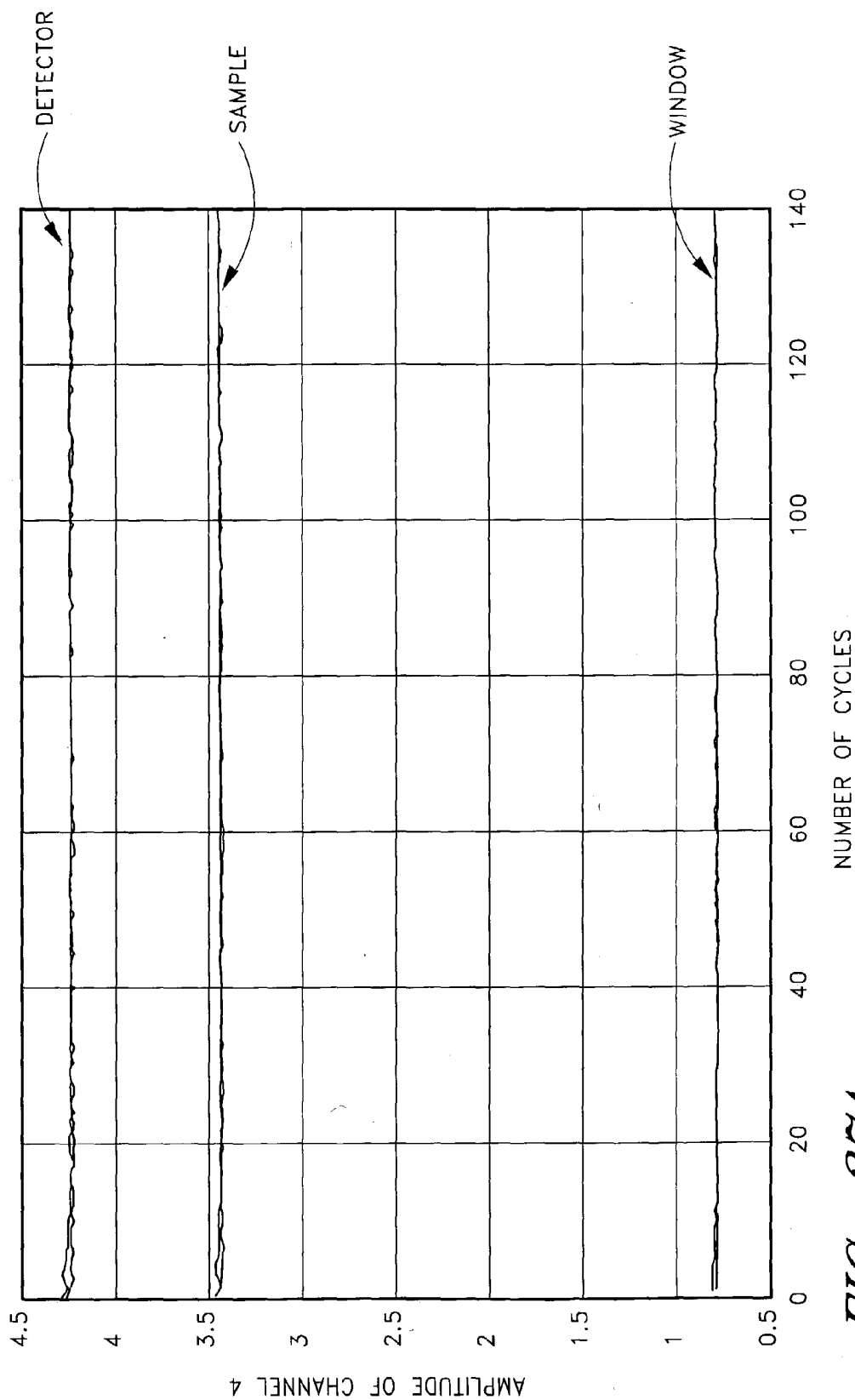


FIG. 37A

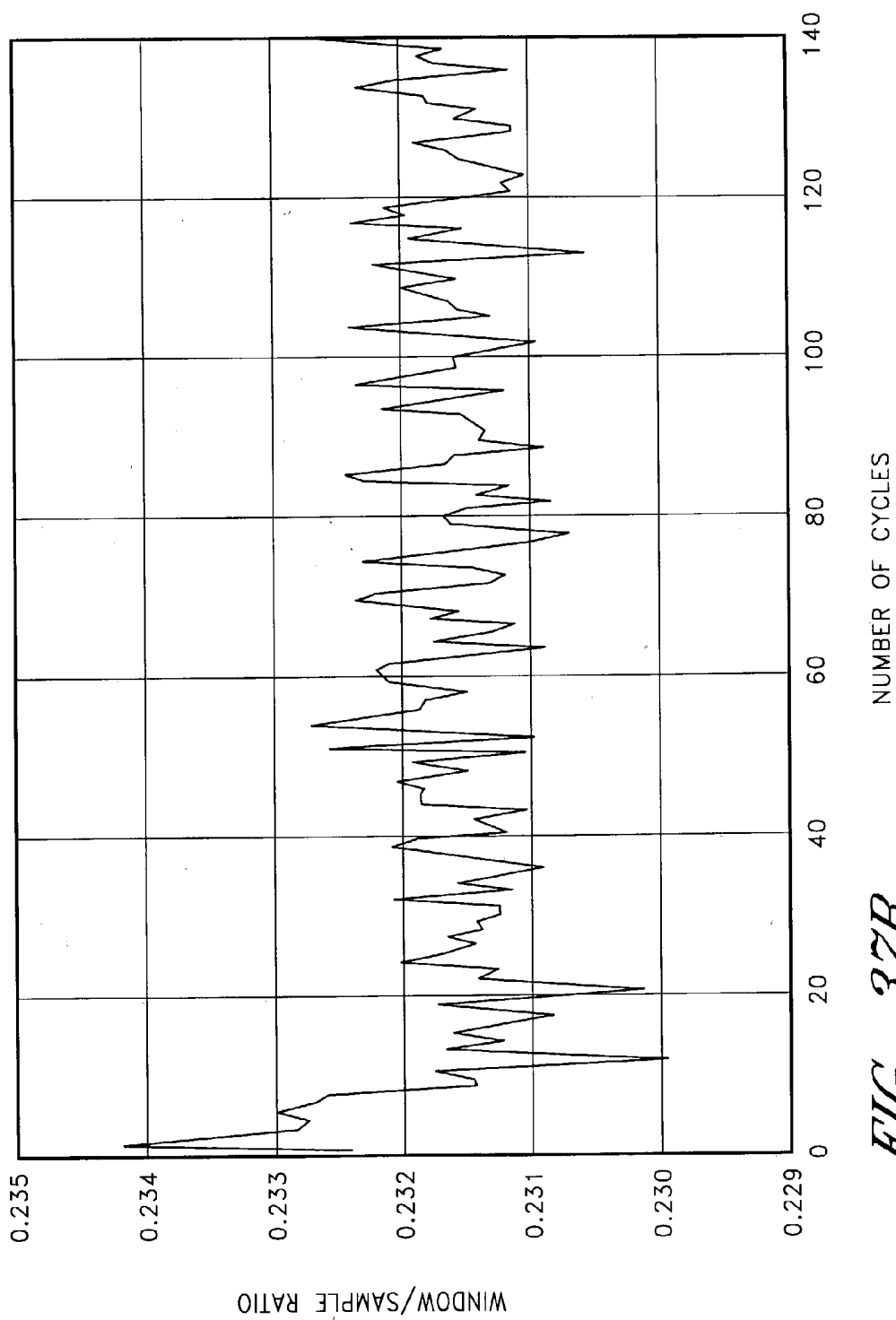


FIG. 37B

**METHOD AND APPARATUS FOR ADJUSTING  
SIGNAL VARIATION OF AN ELECTRONICALLY  
CONTROLLED INFRARED TRANSMISSIVE  
WINDOW**

**CLAIM OF PRIORITY**

[0001] This application claims priority from U.S. Provisional Application No. 60/332,322, filed Nov. 21, 2001, which is incorporated in its entirety by reference herein.

**BACKGROUND OF THE INVENTION**

[0002] 1. Field of the Invention

[0003] The present invention relates generally to optical noninvasive analyte detection systems, and more particularly to methods for correcting the output of such systems to remove contributions not from the sample under study.

[0004] 2. Description of the Related Art

[0005] Millions of diabetics are forced to draw blood on a daily basis to determine their blood glucose levels. In addition, the detection of other blood constituents, such as the determination of the concentration of alcohol in the bloodstream, often requires blood withdrawal in order to perform a precise analysis thereof. A search for a noninvasive methodology to accurately determine blood constituent levels has been substantially expanded in order to alleviate the discomfort of these individuals. A significant advance in the state of the art of noninvasive blood constituent analysis has been realized by the development of spectrometers, including "thermal gradient" spectrometers, which analyze the absorbance of particular wavelengths of infrared ("IR") energy passed through and/or emitted by a sample of tissue. These spectroscopic analytical devices typically employ a window or lens for admitting infrared energy into the device for analysis by infrared detectors.

**SUMMARY OF THE INVENTION**

[0006] In accordance with certain embodiments described herein, an analyte detection system non-invasively determines the concentration of an analyte in a sample generating a sample infrared signal indicative of the concentration of the analyte in the sample. The detection system includes a window assembly for receiving the sample infrared signal. The window assembly is adapted to allow the sample infrared signal to transmit therethrough, and generates a window infrared signal. The detection system further includes at least one detector configured to receive both the window infrared signal and the sample infrared signal transmitted through the window assembly. The detector is further adapted to generate a detector signal in response thereto. The detection system further includes a correction module configured to generate a corrected detector signal indicative of the concentration of the analyte in the sample.

[0007] In accordance with other embodiments described herein, a method improves the sensitivity of a noninvasive infrared analyte detection system having a window assembly and a plurality of detector channels. Each detector channel generates a detector signal in response to infrared emissions from a sample and infrared emissions from the window assembly. The method comprises measuring a window signal for each detector channel. Each window signal has a corresponding amplitude and a corresponding phase delay.

The method further comprises calculating a scaling factor for each detector channel. Each scaling factor is equal to the ratio of the corresponding window signal amplitude and a normalization signal amplitude. The method further comprises subtracting the product of the corresponding scaling factor and a phase-shifted window reference signal from each detector signal, thereby providing a corrected detector signal for each detector channel.

[0008] In accordance with still other embodiments described herein, a method improves the sensitivity of a noninvasive infrared analyte detection system having a window assembly and a plurality of detector channels. Each detector channel is configured to generate signals in response to infrared emissions at a characteristic wavelength. The method comprises providing a reference detector channel. The reference detector channel is configured to generate reference signals in response to infrared emissions at a reference wavelength. The method further comprises measuring a reference window signal using the reference detector channel. The reference window signal has an amplitude corresponding to infrared emissions at the reference wavelength from the window assembly. The method further comprises measuring a plurality of window signals using the plurality of detector channels. Each window signal has an amplitude corresponding to infrared emissions at the characteristic wavelength of the detector channel from the window assembly. The method further comprises calculating a scaling factor for each detector channel. Each scaling factor is equal to the ratio of the corresponding window signal amplitude and the reference window signal amplitude. The method further comprises measuring a reference detector signal using the reference detector channel. The reference detector signal has an amplitude corresponding to infrared emissions at the reference wavelength from the sample and the window assembly. The method further comprises measuring a plurality of detector signals using the plurality of detector channels. Each detector signal has an amplitude corresponding to infrared emissions at the characteristic wavelength of the detector channel from the sample and the window assembly. The method further comprises calculating a corrected detector signal for each detector channel. The corrected detector signal is equal to the corresponding detector signal minus the product of the scaling factor and the reference detector signal from each detector signal.

[0009] In accordance with still other embodiments described herein, a method enhances the accuracy of an analyte measuring system. The analyte measuring system comprises at least one infrared radiation detector and at least one window through which infrared radiation from a sample to be tested is received. The method comprises estimating at least one characteristic of the detector signal produced by infrared radiation generated by said window. The method further comprises compensating the total received detector signal using at least in part said estimated characteristic.

[0010] In accordance with still other embodiments described herein, a method enhances the accuracy of an analyte measuring system. The analyte measuring system comprises at least one infrared radiation detector responsive to infrared radiation in a wavelength range and at least one window through which infrared radiation from a sample to be tested is received. The method comprises reducing the response of the analyte measuring system to infrared radia-

tion emitted by the window. The reducing comprises increasing the transmission of the window in the wavelength range.

[0011] In accordance with still other embodiments described herein, a method enhances the accuracy of an analyte measuring system. The analyte measuring system comprises a first infrared radiation detector generating a first signal having a first phase shift in response to infrared radiation in a first wavelength range, a second infrared radiation detector generating a second signal having a second phase shift in response to infrared radiation in a second wavelength range, and at least one window through which infrared radiation from a sample to be tested is received. The method comprises reducing the response of the analyte measuring system to infrared radiation emitted by the window. The reducing comprises selecting the first wavelength range and the second wavelength range such that the first phase shift and the second phase shift are approximately equal.

[0012] In accordance with still other embodiments described herein, a method enhances the accuracy of an analyte measuring system. The analyte measuring system comprises a first infrared radiation detector generating a first signal having a first phase shift in response to infrared radiation in a first wavelength range, a second infrared radiation detector generating a second signal having a second phase shift in response to infrared radiation in a second wavelength range, and at least one window through which infrared radiation from a sample to be tested is received. The method comprises reducing the response of the analyte measuring system to infrared radiation emitted by the window. The reducing comprises selecting the first wavelength range and the second wavelength range such that the difference between the first phase shift and the second phase shift is minimized.

[0013] In accordance with still other embodiments described herein, a method enhances the accuracy of an analyte measuring system. The analyte measuring system comprises at least one infrared radiation detector responsive to infrared radiation in a wavelength range and at least one window through which infrared radiation from a sample to be tested is received. The sample is coupled to said window. The method comprises stabilizing the coupling between the sample and the window by placing a fluid film between the sample and the window.

#### BRIEF DESCRIPTION OF THE DRAWINGS

[0014] FIG. 1 is a schematic view of a noninvasive optical detection system.

[0015] FIG. 2 is a perspective view of a window assembly for use with the noninvasive detection system.

[0016] FIG. 2A is a plan view of another embodiment of a window assembly for use with the noninvasive detection system.

[0017] FIG. 3 is an exploded schematic view of another embodiment of a window assembly for use with the noninvasive detection system.

[0018] FIG. 4 is a plan view of the window assembly connected to a cooling system.

[0019] FIG. 5 is a plan view of the window assembly connected to a cold reservoir.

[0020] FIG. 6 is a cutaway view of a heat sink for use with the noninvasive detection system.

[0021] FIG. 6A is a cutaway perspective view of a lower portion of the noninvasive detection system of FIG. 1.

[0022] FIG. 6B is an exploded perspective view of a window mounting system for use with the noninvasive optical detection system.

[0023] FIG. 6C is a partial plan view of the window mounting system of FIG. 6B.

[0024] FIG. 6D is a sectional view of the window mounting system of FIG. 6C.

[0025] FIG. 7 is a schematic view of a control system for use with the noninvasive optical detection system.

[0026] FIG. 8 depicts a first methodology for determining the concentration of an analyte of interest.

[0027] FIG. 9 depicts a second methodology for determining the concentration of an analyte of interest.

[0028] FIG. 10 depicts a third methodology for determining the concentration of an analyte of interest.

[0029] FIG. 11 depicts a fourth methodology for determining the concentration of an analyte of interest.

[0030] FIG. 12 depicts a fifth methodology for determining the concentration of an analyte of interest.

[0031] FIG. 13 is a schematic view of a reagentless whole-blood detection system.

[0032] FIG. 14 is a perspective view of one embodiment of a cuvette for use with the reagentless whole-blood detection system.

[0033] FIG. 15 is a plan view of another embodiment of a cuvette for use with the reagentless whole-blood detection system.

[0034] FIG. 16 is a disassembled plan view of the cuvette shown in FIG. 15.

[0035] FIG. 16A is an exploded perspective view of the cuvette of FIG. 15.

[0036] FIG. 17 is a side view of the cuvette of FIG. 15.

[0037] FIG. 18 schematically illustrates the sum of the two infrared signals at the detector represented by the sum of two vectors.

[0038] FIG. 19 schematically illustrates the differential phase drift of the RTD signal and of the difference between the glucose detector and the reference detector signals as functions of time.

[0039] FIG. 20 schematically illustrates the amplitudes of the RTD signal, the glucose signal, and the reference signal as functions of time.

[0040] FIG. 21 schematically illustrates the differential phase (in degrees) plotted as a function of the ratio of the RTD amplitude to the detector amplitude.

[0041] FIG. 22 schematically illustrates the optical transmission of various CVD-diamond windows.

[0042] FIG. 23 schematically illustrates the differential phase drift for continuous measurements of three measurement runs for two trials.

[0043] FIG. 24 schematically illustrates the detector signal amplitude change for continuous measurements of three measurement runs for two trials.

[0044] FIG. 25 schematically illustrates the detector signal phase change for continuous measurements of three measurement runs for two trials.

[0045] FIG. 26 schematically illustrates the initial RTD amplitude plotted against the initial detector amplitude for a series of measurements comparing dry skin samples (in this case, human arms) with dry skin samples plus mineral oil.

[0046] FIG. 27 schematically illustrates a plot of  $g(f, \delta)$  as a function of  $f$  for various values of  $\delta$  in millidegrees.

[0047] FIG. 28 schematically illustrates the ratio of the RTD signal to the detector amplitude at the beginning of each measurement plotted against the differential phase at the beginning of each measurement for a series of dry arms measured over three days.

[0048] FIG. 29 schematically illustrates the accuracy needed for the amplitude of the correction signal as a function of the phase angle difference between the two spectral lines over a given range for the noninvasive system.

[0049] FIGS. 30A-E schematically illustrate various exemplary embodiments of the window assembly.

[0050] FIG. 31 is a flow diagram of an embodiment of a method for improving the sensitivity of a noninvasive infrared analyte detection system having a window assembly and a plurality of detector channels.

[0051] FIG. 32A schematically illustrates an exemplary plot of the measured phase difference as a function of glucose concentration for five calibration samples with known glucose concentration levels.

[0052] FIG. 32B schematically illustrates an exemplary plot of the sensitivity as a function of the window reference phase shift.

[0053] FIG. 33 schematically illustrates the wavelength dependence of the window transmission.

[0054] FIG. 34 is a flow diagram of an embodiment of a method for improving the sensitivity of a noninvasive infrared analyte detection system having a window assembly and a plurality of detector channels.

[0055] FIG. 35 schematically illustrates the scaling factors for various wavelengths in an exemplary embodiment.

[0056] FIG. 36 schematically illustrates the measured differential phase before and after performing the optical window signal correction in an exemplary embodiment.

[0057] FIG. 37A schematically illustrates the amplitudes of the detector signal, the sample signal, and the window signal for one of the detector channels.

[0058] FIG. 37B schematically illustrates the ratio of the window signal to the sample signal for one of the detector channels.

## DETAILED DESCRIPTION

[0059] Although certain preferred embodiments and examples are disclosed below, it will be understood by those skilled in the art that the invention extends beyond the specifically disclosed embodiments to other alternative embodiments and/or uses of the invention and obvious modifications and equivalents thereof. Thus, it is intended that the scope of the invention herein disclosed should not be limited by the particular disclosed embodiments described below.

### I. OVERVIEW OF ANALYTE DETECTION SYSTEMS

[0060] Disclosed herein are analyte detection systems, including a noninvasive system discussed largely in part A below and a whole-blood system discussed largely in part B below. Also disclosed are various methods, including methods for detecting the concentration of an analyte in a material sample. Both the noninvasive system/method and the whole-blood system/method can employ optical measurement. As used herein with reference to measurement apparatus and methods, "optical" is a broad term and is used in its ordinary sense and refers, without limitation, to identification of the presence or concentration of an analyte in a material sample without requiring a chemical reaction to take place. As discussed in more detail below, the two approaches each can operate independently to perform an optical analysis of a material sample. The two approaches can also be combined in an apparatus, or the two approaches can be used together to perform different steps of a method.

[0061] In one embodiment, the two approaches are combined to perform calibration of an apparatus, e.g., of an apparatus that employs a noninvasive approach. In another embodiment, an advantageous combination of the two approaches performs an invasive measurement to achieve greater accuracy and a whole-blood measurement to minimize discomfort to the patient. For example, the whole-blood technique may be more accurate than the noninvasive technique at certain times of the day, e.g., at certain times after a meal has been consumed, or after a drug has been administered.

[0062] It should be understood, however, that any of the disclosed devices may be operated in accordance with any suitable detection methodology, and that any disclosed method may be employed in the operation of any suitable device. Furthermore, the disclosed devices and methods are applicable in a wide variety of situations or modes of operation, including but not limited to invasive, noninvasive, intermittent or continuous measurement, subcutaneous implantation, wearable detection systems, or any combination thereof.

[0063] Any method which is described and illustrated herein is not limited to the exact sequence of acts described, nor is it necessarily limited to the practice of all of the acts set forth. Other sequences of events or acts, or less than all of the events, or simultaneous occurrence of the events, may be utilized in practicing the method(s) in question.

[0064] A. Noninvasive System

[0065] 1. Monitor Structure

[0066] FIG. 1 depicts a noninvasive optical detection system (hereinafter "noninvasive system") 10 in a presently

preferred configuration. The depicted noninvasive system **10** is particularly suited for noninvasively detecting the concentration of an analyte in a material sample S, by observing the infrared energy emitted by the sample, as will be discussed in further detail below.

[0067] As used herein, the term “noninvasive” is a broad term and is used in its ordinary sense and refers, without limitation, to analyte detection devices and methods which have the capability to determine the concentration of an analyte in in-vivo tissue samples or bodily fluids. It should be understood, however, that the noninvasive system **10** disclosed herein is not limited to noninvasive use, as the noninvasive system **10** may be employed to analyze an in-vitro fluid or tissue sample which has been obtained invasively or noninvasively. As used herein, the term “invasive” (or, alternatively, “traditional”) is a broad term and is used in its ordinary sense and refers, without limitation, to analyte detection methods which involve the removal of fluid samples through the skin. As used herein, the term “material sample” is a broad term and is used in its ordinary sense and refers, without limitation, to any collection of material which is suitable for analysis by the noninvasive system **10**. For example, the material sample S may comprise a tissue sample, such as a human forearm, placed against the noninvasive system **10**. The material sample S may also comprise a volume of a bodily fluid, such as whole blood, blood component(s), interstitial fluid or intercellular fluid obtained invasively, or saliva or urine obtained noninvasively, or any collection of organic or inorganic material. As used herein, the term “analyte” is a broad term and is used in its ordinary sense and refers, without limitation, to any chemical species the presence or concentration of which is sought in the material sample S by the noninvasive system **10**. For example, the analyte(s) which may be detected by the noninvasive system **10** include but not are limited to glucose, ethanol, insulin, water, carbon dioxide, blood oxygen, cholesterol, bilirubin, ketones, fatty acids, lipoproteins, albumin, urea, creatinine, white blood cells, red blood cells, hemoglobin, oxygenated hemoglobin, carboxyhemoglobin, organic molecules, inorganic molecules, pharmaceuticals, cytochrome, various proteins and chromophores, microcalcifications, electrolytes, sodium, potassium, chloride, bicarbonate, and hormones. As used herein to describe measurement techniques, the term “continuous” is a broad term and is used in its ordinary sense and refers, without limitation, to the taking of discrete measurements more frequently than about once every **10** minutes, and/or the taking of a stream or series of measurements or other data over any suitable time interval, for example, over an interval of one to several seconds, minutes, hours, days, or longer. As used herein to describe measurement techniques, the term “intermittent” is a broad term and is used in its ordinary sense and refers, without limitation, to the taking of measurements less frequently than about once every **10** minutes.

[0068] The noninvasive system **10** preferably comprises a window assembly **12**, although in some embodiments the window assembly **12** may be omitted. One function of the window assembly **12** is to permit infrared energy E to enter the noninvasive system **10** from the sample S when it is placed against an upper surface **12a** of the window assembly **12**. The window assembly **12** includes a heater layer (see discussion below) which is employed to heat the material sample S and stimulate emission of infrared energy therefrom. A cooling system **14**, preferably comprising a Peltier

type thermoelectric device, is in thermally conductive relation to the window assembly **12** so that the temperature of the window assembly **12** and the material sample S can be manipulated in accordance with a detection methodology discussed in greater detail below. The cooling system **14** includes a cold surface **14a** which is in thermally conductive relation to a cold reservoir **16** and the window assembly **12**, and a hot surface **14b** which is in thermally conductive relation to a heat sink **18**.

[0069] As the infrared energy E enters the noninvasive system **10**, it first passes through the window assembly **12**, then through an optical mixer **20**, and then through a collimator **22**. The optical mixer **20** preferably comprises a light pipe having highly reflective inner surfaces which randomize the directionality of the infrared energy E as it passes therethrough and reflects against the mixer walls. The collimator **22** also comprises a light pipe having highly-reflective inner walls, but the walls diverge as they extend away from the mixer **20**. The divergent walls cause the infrared energy E to tend to straighten as it advances toward the wider end of the collimator **22**, due to the angle of incidence of the infrared energy when reflecting against the collimator walls.

[0070] From the collimator **22** the infrared energy E passes through an array of filters **24**, each of which allows only a selected wavelength or band of wavelengths to pass therethrough. These wavelengths/bands are selected to highlight or isolate the absorptive effects of the analyte of interest in the detection methodology discussed in greater detail below. Each filter **24** is preferably in optical communication with a concentrator **26** and an infrared detector **28**. The concentrators **26** have highly reflective, converging inner walls which concentrate the infrared energy as it advances toward the detectors **28**, increasing the density of the energy incident upon the detectors **28**.

[0071] The detectors **28** are in electrical communication with a control system **30** which receives electrical signals from the detectors **28** and computes the concentration of the analyte in the sample S. The control system **30** is also in electrical communication with the window **12** and cooling system **14**, so as to monitor the temperature of the window **12** and/or cooling system **14** and control the delivery of electrical power to the window **12** and cooling system **14**.

[0072] a. Window Assembly

[0073] A preferred configuration of the window assembly **12** is shown in perspective, as viewed from its underside (in other words, the side of the window assembly **12** opposite the sample S), in FIG. 2. The window assembly **12** generally comprises a main layer **32** formed of a highly infrared-transmissive material and a heater layer **34** affixed to the underside of the main layer **32**. The main layer **32** is preferably formed from diamond, most preferably from chemical-vapor-deposited (“CVD”) diamond, with a preferred thickness of about 0.25 millimeters. In other embodiments alternative materials which are highly infrared-transmissive, such as silicon or germanium, may be used in forming the main layer **32**.

[0074] The heater layer **34** preferably comprises bus bars **36** located at opposing ends of an array of heater elements **38**. The bus bars **36** are in electrical communication with the elements **38** so that, upon connection of the bus bars **36** to

a suitable electrical power source (not shown) a current may be passed through the elements 38 to generate heat in the window assembly 12. The heater layer 34 may also include one or more temperature sensors (not shown), such as thermistors or resistance temperature devices (RTDs), to measure the temperature of the window assembly 12 and provide temperature feedback to the control system 30 (see FIG. 1).

[0075] Still referring to FIG. 2, the heater layer 34 preferably comprises a first adhesion layer of gold or platinum (hereinafter referred to as the "gold" layer) deposited over an alloy layer which is applied to the main layer 32. The alloy layer comprises a material suitable for implementation of the heater layer 34, such as, by way of example, 10/90 titanium/tungsten, titanium/platinum, nickel/chromium, or other similar material. The gold layer preferably has a thickness of about 4000 Å, and the alloy layer preferably has a thickness ranging between about 300 Å and about 500 Å. The gold layer and/or the alloy layer may be deposited onto the main layer 32 by chemical deposition including, but not necessarily limited to, vapor deposition, liquid deposition, plating, laminating, casting, sintering, or other forming or deposition methodologies well known to those of ordinary skill in the art. If desired, the heater layer 34 may be covered with an electrically insulating coating which also enhances adhesion to the main layer 32. One preferred coating material is aluminum oxide. Other acceptable materials include, but are not limited to, titanium dioxide or zinc selenide.

[0076] The heater layer 34 may incorporate a variable pitch distance between centerlines of adjacent heater elements 38 to maintain a constant power density, and promote a uniform temperature, across the entire layer 34. Where a constant pitch distance is employed, the preferred distance is at least about 50-100 microns. Although the heater elements 38 generally have a preferred width of about 25 microns, their width may also be varied as needed for the same reasons stated above.

[0077] Alternative structures suitable for use as the heater layer 34 include, but are not limited to, thermoelectric heaters, radiofrequency (RF) heaters, infrared radiation heaters, optical heaters, heat exchangers, electrical resistance heating grids, wire bridge heating grids, or laser heaters. Whichever type of heater layer is employed, it is preferred that the heater layer obscures about 10% or less of the window assembly 12.

[0078] In a preferred embodiment, the window assembly 12 comprises substantially only the main layer 32 and the heater layer 34. Thus, when installed in an optical detection system such as the noninvasive system 10 shown in FIG. 1, the window assembly 12 will facilitate a minimally obstructed optical path between a (preferably flat) upper surface 12a of the window assembly 12 and the infrared detectors 28 of the noninvasive system 10. The optical path 32 in the preferred noninvasive system 10 proceeds only through the main layer 32 and heater layer 34 of the window assembly 12 (including any antireflective, index-matching, electrical insulating or protective coatings applied thereto or placed therein), through the optical mixer 20 and collimator 22 and to the detectors 28.

[0079] FIG. 2A shows another embodiment of the window assembly 12, that may be used in place of the window assembly 12 depicted in FIG. 2. The window assembly 12

shown in FIG. 2A may be similar to that shown in FIG. 2, except as described below. In the embodiment of FIG. 2A the main layer 32 has a preferred thickness of up to about 0.012" and more preferably about 0.010" or less. The heater layer 34 may also include one or more resistance temperature devices (RTD's) 55 to measure the temperature of the window assembly 12 and provide temperature feedback to a control system 30. The RTDs 55 terminate in RTD connection pads 57.

[0080] In the embodiment of FIG. 2A, the heater elements 38 are typically provided with a width of about 25 microns. The pitch distance separating centerlines of adjacent heater elements 38 may be reduced, and/or the width of the heater elements 38 may be increased, in the regions of the window assembly 12 near the point(s) of contact with the thermal diffuser 410 (see FIGS. 6B-6D and discussion below). This arrangement advantageously promotes an isothermal temperature profile at the upper surface of the main layer 32 despite thermal contact with the thermal diffuser.

[0081] The embodiment shown in FIG. 2A includes a plurality of heater elements 38 of substantially equal width which are variably spaced across the width of the main layer 32. In the embodiment of FIG. 2A, the centerlines of the heater elements 38 are spaced at a first pitch distance of about 0.0070" at peripheral portions 34a of the heater layer 34, and at a second pitch distance of about 0.015" at a central portion 34b of the main layer 32. The heater elements 38 closest to the center are preferably sufficiently spaced to allow the RTDs 55 to extend therebetween. In the embodiment of FIG. 2A, the main layer 32 includes peripheral regions 32a which extend about 0.053" from the outermost heater element on each side of the heater layer 34 to the adjacent edge of the main layer 32. As shown, the bus bars 36 are preferably configured and segmented to allow space for the RTDs 55 and the RTD connection pads 57, in intermediate gaps 36a. The RTDs 55 preferably extend into the array of heater elements 38 by distance that is slightly longer than half of the length of an individual heater element 38. In alternative embodiments, the RTDs 55 may be located at the edges of the main layer 32, or at other locations as desired for a particular noninvasive system.

[0082] With continued reference to FIG. 2A, the peripheral regions of the main layer 32 may include metallized edge portions 35 for facilitating connection to the diffuser 410 (discussed below in connection with FIGS. 6B-6D). The metallized edge portions 35 may be formed by the same or similar processes used in forming the heater elements 38 and RTDs 55. In the embodiment of FIG. 2A, the edge portions 35 are typically between about 0.040" and about 0.060" wide by about 0.450" and about 0.650" long, and in one embodiment, they are about 0.050" by about 0.550". Other dimensions may be appropriately used so long as the window assembly 12 may be joined in thermal communication with the diffuser 410 as needed.

[0083] In the embodiment shown in FIG. 2A, the main layer 32 is about 0.690" long by about 0.571" wide, and the heater layer (excluding the metallized edge portions 35) is about 0.640" long by about 0.465" wide. The main layer 32 is about 0.010"-0.012" thick, and is advantageously thinner than about 0.010" where possible. Each heater element 38 is about 0.570" long, and each peripheral region 34a is about 0.280" wide. These dimensions are merely exemplary; of course, other dimensions may be used as desired.

[0084] FIG. 3 depicts an exploded side view of an alternative configuration for the window assembly 12, which may be used in place of the configuration shown in FIG. 2. The window assembly 12 depicted in FIG. 3 includes near its upper surface (the surface intended for contact with the sample S) a highly infrared-transmissive, thermally conductive spreader layer 42. Underlying the spreader layer 42 is a heater layer 44. A thin electrically insulating layer (not shown), such as layer of aluminum oxide, titanium dioxide or zinc selenide, may be disposed between the heater layer 44 and the spreader layer 42. (An aluminum oxide layer also increases adhesion of the heater layer 44 to the spreader layer 42.) Adjacent to the heater layer 44 is a thermal insulating and impedance matching layer 46. Adjacent to the thermal insulating layer 46 is a thermally conductive inner layer 48. The spreader layer 42 is coated on its top surface with a thin layer of protective coating 50. The bottom surface of the inner layer 48 is coated with a thin overcoat layer 52. Preferably, the protective coating 50 and the overcoat layer 52 have antireflective properties.

[0085] The spreader layer 42 is preferably formed of a highly infrared-transmissive material having a high thermal conductivity sufficient to facilitate heat transfer from the heater layer 44 uniformly into the material sample S when it is placed against the window assembly 12. Other effective materials include, but are not limited to, CVD diamond, diamondlike carbon, gallium arsenide, germanium, and other infrared-transmissive materials having sufficiently high thermal conductivity. Preferred dimensions for the spreader layer 42 are about one inch in diameter and about 0.010 inch thick. As shown in FIG. 3, a preferred embodiment of the spreader layer 42 incorporates a beveled edge. Although not required, an approximate 45-degree bevel is preferred.

[0086] The protective layer 50 is intended to protect the top surface of the spreader layer 42 from damage. Ideally, the protective layer is highly infrared-transmissive and highly resistant to mechanical damage, such as scratching or abrasion. It is also preferred that the protective layer 50 and the overcoat layer 52 have high thermal conductivity and antireflective and/or index-matching properties. A satisfactory material for use as the protective layer 50 and the overcoat layer 52 is the multi-layer Broad Band Anti-Reflective Coating produced by Deposition Research Laboratories, Inc. of St. Charles, Mo. Diamondlike carbon coatings are also suitable.

[0087] Except as noted below, the heater layer 44 is generally similar to the heater layer 34 employed in the window assembly shown in FIG. 2. Alternatively, the heater layer 44 may comprise a doped infrared-transmissive material, such as a doped silicon layer, with regions of higher and lower resistivity. The heater layer 44 preferably has a resistance of about 2 ohms and has a preferred thickness of about 1,500 angstroms. A preferred material for forming the heater layer 44 is a gold alloy, but other acceptable materials include, but are not limited to, platinum, titanium, tungsten, copper, and nickel.

[0088] The thermal insulating layer 46 prevents the dissipation of heat from the heater element 44 while allowing the cooling system 14 to effectively cool the material sample S (see FIG. 1). This layer 46 comprises a material having thermally insulative (e.g., lower thermal conductivity than

the spreader layer 42) and infrared transmissive qualities. A preferred material is a germanium-arsenic-selenium compound of the calcogenide glass family known as AMTIR-1 produced by Amorphous Materials, Inc. of Garland, Tex. The pictured embodiment has a diameter of about 0.85 inches and a preferred thickness in the range of about 0.005 to about 0.010 inches. As heat generated by the heater layer 44 passes through the spreader layer 42 into the material sample S, the thermal insulating layer 46 insulates this heat.

[0089] The inner layer 48 is formed of thermally conductive material, preferably crystalline silicon formed using a conventional floatzone crystal growth method. The purpose of the inner layer 48 is to serve as a cold-conducting mechanical base for the entire layered window assembly.

[0090] The overall optical transmission of the window assembly 12 shown in FIG. 3 is preferably at least 70%. The window assembly 12 of FIG. 3 is preferably held together and secured to the noninvasive system 10 by a holding bracket (not shown). The bracket is preferably formed of a glass-filled plastic, for example Ultem 2300, manufactured by General Electric. Ultem 2300 has low thermal conductivity which prevents heat transfer from the layered window assembly 12.

#### [0091] b. Cooling System

[0092] The cooling system 14 (see FIG. 1) preferably comprises a Peltier-type thermoelectric device. Thus, the application of an electrical current to the preferred cooling system 14 causes the cold surface 14a to cool and causes the opposing hot surface 14b to heat up. The cooling system 14 cools the window assembly 12 via the situation of the window assembly 12 in thermally conductive relation to the cold surface 14a of the cooling system 14. It is contemplated that the cooling system 14, the heater layer 34, or both, can be operated to induce a desired time-varying temperature in the window assembly 12 to create an oscillating thermal gradient in the sample S, in accordance with various analyte-detection methodologies discussed herein.

[0093] Preferably, the cold reservoir 16 is positioned between the cooling system 14 and the window assembly 12, and functions as a thermal conductor between the system 14 and the window assembly 12. The cold reservoir 16 is formed from a suitable thermally conductive material, preferably brass. Alternatively, the window assembly 12 can be situated in direct contact with the cold surface 14a of the cooling system 14.

[0094] In alternative embodiments, the cooling system 14 may comprise a heat exchanger through which a coolant, such as air, nitrogen or chilled water, is pumped, or a passive conduction cooler such as a heat sink. As a further alternative, a gas coolant such as nitrogen may be circulated through the interior of the noninvasive system 10 so as to contact the underside of the window assembly 12 (see FIG. 1) and conduct heat therefrom.

[0095] FIG. 4 is a top schematic view of a preferred arrangement of the window assembly 12 (of the types shown in FIGS. 2 or 2A) and the cold reservoir 16, and FIG. 5 is a top schematic view of an alternative arrangement in which the window assembly 12 directly contacts the cooling system 14. The cold reservoir 16/cooling system 14 preferably contacts the underside of the window assembly 12 along opposing edges thereof, on either side of the heater layer 34.

With thermal conductivity thus established between the window assembly 12 and the cooling system 14, the window assembly can be cooled as needed during operation of the noninvasive system 10. In order to promote a substantially uniform or isothermal temperature profile over the upper surface of the window assembly 12, the pitch distance between centerlines of adjacent heater elements 38 may be made smaller (thereby increasing the density of heater elements 38) near the region(s) of contact between the window assembly 12 and the cold reservoir 16/cooling system 14. As a supplement or alternative, the heater elements 38 themselves may be made wider near these regions of contact. As used herein, "isothermal" is a broad term and is used in its ordinary sense and refers, without limitation, to a condition in which, at a given point in time, the temperature of the window assembly 12 or other structure is substantially uniform across a surface intended for placement in thermally conductive relation to the material sample S. Thus, although the temperature of the structure or surface may fluctuate over time, at any given point in time the structure or surface may nonetheless be isothermal.

[0096] The heat sink 18 drains waste heat from the hot surface 14b of the cooling system 16 and stabilizes the operational temperature of the noninvasive system 10. The preferred heat sink 18 (see FIG. 6) comprises a hollow structure formed from brass or any other suitable material having a relatively high specific heat and high heat conductivity. The heat sink 18 has a conduction surface 18a which, when the heat sink 18 is installed in the noninvasive system 18, is in thermally conductive relation to the hot surface 14b of the cooling system 14 (see FIG. 1). A cavity 54 is formed in the heat sink 18 and preferably contains a phase-change material (not shown) to increase the capacity of the sink 18. A preferred phase change material is a hydrated salt, such as calciumchloride hexahydrate, available under the name TH29 from PCM Thermal Solutions, Inc., of Naperville, Ill. Alternatively, the cavity 54 may be omitted to create a heat sink 18 comprising a solid, unitary mass. The heat sink 18 also forms a number of fins 56 to further increase the conduction of heat from the sink 18 to surrounding air.

[0097] Alternatively, the heat sink 18 may be formed integrally with the optical mixer 20 and/or the collimator 22 as a unitary mass of rigid, heat-conductive material such as brass or aluminum. In such a heat sink, the mixer 20 and/or collimator 22 extend axially through the heat sink 18, and the heat sink defines the inner walls of the mixer 20 and/or collimator 22. These inner walls are coated and/or polished to have appropriate reflectivity and nonabsorbance in infrared wavelengths as will be further described below. Where such a unitary heat sink-mixer-collimator is employed, it is desirable to thermally insulate the detector array from the heat sink.

[0098] It should be understood that any suitable structure may be employed to heat and/or cool the material sample S, instead of or in addition to the window assembly 12/cooling system 14 disclosed above, so long a proper degree of cycled heating and/or cooling are imparted to the material sample S. In addition other forms of energy, such as but not limited to light, radiation, chemically induced heat, friction and vibration, may be employed to heat the material sample S. It will be further appreciated that heating of the sample can be achieved by any suitable method, such as convection, conduction, radiation, etc.

#### [0099] c. Window Mounting System

[0100] FIG. 6B illustrates an exploded view of a window mounting system 400 which, in one embodiment, is employed as part of the noninvasive system 10 disclosed above. Where employed in connection with the noninvasive system 10, the window mounting system 400 supplements or, where appropriate, replaces any of the window assembly 12, cooling system 14, cold reservoir 16 and heat sink 18 shown in FIG. 1. In one embodiment, the window mounting system 400 is employed in conjunction with the window assembly 12 depicted in FIG. 2A; in alternative embodiments, the window assemblies shown in FIGS. 2 and 3 and described above may also be used in conjunction with the window mounting system 400 illustrated in FIG. 6B.

[0101] In the window mounting system 400, the window assembly 12 is physically and electrically connected (typically by soldering) to a first printed circuit board ("first PCB") 402. The window assembly 12 is also in thermally conductive relation (typically by contact) to a thermal diffuser 410. The window assembly may also be fixed to the diffuser 410 by soldering.

[0102] The thermal diffuser 410 generally comprises a heat spreader layer 412 which, as mentioned, preferably contacts the window assembly 12, and a conductive layer 414 which is typically soldered to the heat spreader layer 412. The conductive layer 414 may then be placed in direct contact with a cold side 418a of a thermoelectric cooler (TEC) 418 or other cooling device. The TEC 418, which in one embodiment comprises a 25 W TEC manufactured by MELCOR, is in electrical communication with a second PCB 403, which includes TEC power leads 409 and TEC power terminals 411 for connection of the TEC 418 to an appropriate power source (not shown). The second PCB 403 also includes contacts 408 for connection with RTD terminals 407 (see FIG. 6C) of the first PCB 402. A heat sink 419, which may take the form of the illustrated water jacket, the heat sink 18 shown in FIG. 6, any other heat sink structures mentioned herein, or any other appropriate device, is in thermal communication with a hot side 418b of the TEC 418 (or other cooling device), in order to remove any excess heat created by the TEC 418.

[0103] FIG. 6C illustrates a plan view of the interconnection of the window assembly 12, the first PCB 402, the diffuser 410 and the thermoelectric cooler 418. The first PCB includes RTD bonding leads 406 and heater bonding pads 404 which permit attachment of the RTDs 55 and bus bars 36, respectively, of the window assembly 12 to the first PCB 402 via soldering or other conventional techniques. Electrical communication is thus established between the heater elements 38 of the heater layer 34, and heater terminals 405 formed in the heater bonding pads 404. Similarly, electrical communication is established between the RTDs 55 and RTD terminals 407 formed at the ends of the RTD bonding leads 406. Electrical connections can be established with the heater elements 38 and the RTDs 55 via simple connection to the terminals 405, 407 of the first PCB 402.

[0104] With further reference to FIGS. 2A and 6B-6C, the heat spreader layer 412 of the thermal diffuser 410 contacts the underside of the main layer 32 of the window assembly 12 via a pair of rails 416. The rails 416 may contact the main layer 32 at the metallized edge portions 35, or at any other

appropriate location. The physical and thermal connection between the rails 416 and the window main layer 32 may be achieved by soldering, as indicated above. Alternatively, the connection may be achieved by an adhesive such as epoxy, or any other appropriate method. The material chosen for the window main layer 32 is preferably sufficiently thermally conductive that heat may be quickly removed from the main layer 32 through the rails 416, the diffuser 410, and the TEC 128.

[0105] FIG. 6D shows a cross-sectional view of the assembly of FIG. 6C through line 22-22. As can be seen in FIG. 6D, the window assembly 12 contacts the rails 416 of the heat spreader layer 412. The conductive layer 414 underlies the spreader layer 412 and may comprise protrusions 426 configured to extend through openings 424 formed in the spreader layer 412. The openings 424 and protrusions 426 are sized to leave sufficient expansion space therebetween, to allow expansion and contraction of the conductive layer 414 without interference with, or causing deformation of, the window assembly 12 or the heat spreader layer 412. Moreover, the protrusions 426 and openings 424 coact to prevent displacement of the spreader layer 412 with respect to the conductive layer 414 as the conductive layer 414 expands and contracts.

[0106] The thermal diffuser 410 provides a thermal impedance between the TEC 418 and the window assembly 12, which impedance is selected to drain heat from the window assembly at a rate proportional to the power output of the heater layer 34. In this way, the temperature of the main layer 32 can be rapidly cycled between a "hot" and a "cold" temperatures, thereby allowing a time-varying thermal gradient to be induced in a sample S placed against the window assembly 12.

[0107] The heat spreader layer 412 is preferably made of a material which has substantially the same coefficient of thermal expansion as the material used to form the window assembly main layer 32, within the expected operating temperature range. Preferably, both the material used to form the main layer 32 and the material used to form the heat spreader layer 412 have substantially the same, extremely low, coefficient of thermal expansion. For this reason, CVD diamond is preferred for the main layer 32 (as mentioned above); with a CVD diamond main layer 32 the preferred material for the heat spreader layer 412 is Invar. Invar advantageously has an extremely low coefficient of thermal expansion and a relatively high thermal conductivity. Because Invar is a metal, the main layer 32 and the heat spreader layer 412 can be thermally bonded to one another with little difficulty. Alternatively, other materials may be used for the heat spreader layer 412; for example, any of a number of glass and ceramic materials with low coefficients of thermal expansion may be employed.

[0108] The conductive layer 414 of the thermal diffuser 410 is typically a highly thermally conductive material such as copper (or, alternatively, other metals or non-metals exhibiting comparable thermal conductivities). The conductive layer 414 is typically soldered or otherwise bonded to the underside of the heat spreader layer 412.

[0109] In the illustrated embodiment, the heat spreader layer 412 may be constructed according to the following dimensions, which are to be understood as exemplary; accordingly the dimensions may be varied as desired. The

heat spreader layer 412 has an overall length and width of about 1.170", with a central opening of about 0.590" long by 0.470" wide. Generally, the heat spreader layer 412 is about 0.030" thick; however, the rails 416 extend a further 0.045" above the basic thickness of the heat spreader layer 412. Each rail 416 has an overall length of about 0.710"; over the central 0.525" of this length each rail 416 is about 0.053" wide. On either side of the central width each rail 416 tapers, at a radius of about 0.6", down to a width of about 0.023". Each opening 424 is about 0.360" long by about 0.085" wide, with comers rounded at a radius of about 0.033".

[0110] In the illustrated embodiment, conductive layer 414 may be constructed according to the following dimensions, which are to be understood as exemplary; accordingly the dimensions may be varied as desired. The conductive layer 414 has an overall length and width of about 1.170", with a central opening of about 0.590" long by 0.470" wide. Generally, the conductive layer 412 is about 0.035" thick; however, the protrusions 426 extend a further 0.075"-0.085" above the basic thickness of the conductive layer 414. Each protrusion 426 is about 0.343" long by about 0.076" wide, with comers rounded at a radius of about 0.035".

[0111] As shown in FIG. 6B, first and second clamping plates 450 and 452 may be used to clamp the portions of the window mounting system 400 to one another. For example, the second clamping plate 452 is configured to clamp the window assembly 12 and the first PCB 402 to the diffuser 410 with screws or other fasteners extending through the openings shown in the second clamping plate 452, the heat spreader layer 412 and the conductive layer 414. Similarly, the first clamping plate 450 is configured overlies the second clamping plate 452 and clamp the rest of the window mounting system 400 to the heat sink 419, thus sandwiching the second clamping plate 452, the window assembly 12, the first PCB 402, the diffuser 410, the second PCB 403, and the TEC 418 therebetween. The first clamping plate 450 prevents undesired contact between the sample S and any portion of the window mounting system 400, other than the window assembly 12 itself. Other mounting plates and mechanisms may also be used as desired.

[0112] d. Optics

[0113] As shown in FIG. 1, the optical mixer 20 comprises a light pipe with an inner surface coating which is highly reflective and minimally absorptive in infrared wavelengths, preferably a polished gold coating, although other suitable coatings may be used where other wavelengths of electromagnetic radiation are employed. The pipe itself may be fabricated from a another rigid material such as aluminum or stainless steel, as long as the inner surfaces are coated or otherwise treated to be highly reflective. Preferably, the optical mixer 20 has a rectangular cross-section (as taken orthogonal to the longitudinal axis A-A of the mixer 20 and the collimator 22), although other cross-sectional shapes, such as other polygonal shapes or circular or elliptical shapes, may be employed in alternative embodiments. The inner walls of the optical mixer 20 are substantially parallel to the longitudinal axis A-A of the mixer 20 and the collimator 22. The highly reflective and substantially parallel inner walls of the mixer 20 maximize the number of times the infrared energy E will be reflected between the walls of the mixer 20, thoroughly mixing the infrared energy E as it propagates through the mixer 20. In a presently preferred

embodiment, the mixer **20** is about 1.2 inches to 2.4 inches in length and its cross-section is a rectangle of about 0.4 inches by about 0.6 inches. Of course, other dimensions may be employed in constructing the mixer **20**. In particular it is be advantageous to miniaturize the mixer or otherwise make it as small as possible

[0114] Still referring to **FIG. 1**, the collimator **22** comprises a tube with an inner surface coating which is highly reflective and minimally absorptive in infrared wavelengths, preferably a polished gold coating. The tube itself may be fabricated from another rigid material such as aluminum, nickel or stainless steel, as long as the inner surfaces are coated or otherwise treated to be highly reflective. Preferably, the collimator **22** has a rectangular cross-section, although other cross-sectional shapes, such as other polygonal shapes or circular, parabolic or elliptical shapes, may be employed in alternative embodiments. The inner walls of the collimator **22** diverge as they extend away from the mixer **20**. Preferably, the inner walls of the collimator **22** are substantially straight and form longitudinal axis A-A of the mixer **20** and the collimator **22**, so that the infrared energy E will strike the surface of the filters **24** at an angle as close to 90 degrees as possible.

[0115] In a presently preferred embodiment, the collimator is about 7.5 inches in length. At its narrow end **22a**, the cross-section of the collimator **22** is a rectangle of about 0.4 inches by 0.6 inches. At its wide end **22b**, the collimator **22** has a rectangular cross-section of about 1.8 inches by 2.6 inches. Preferably, the collimator **22** aligns the infrared energy E to an angle of incidence (with respect to the longitudinal axis A-A) of about 0-15 degrees before the energy E impinges upon the filters **24**. Of course, other dimensions or incidence angles may be employed in constructing and operating the collimator **22**.

[0116] With further reference to **FIGS. 1 and 6A**, each concentrator **26** comprises a tapered surface oriented such that its wide end **26a** is adapted to receive the infrared energy exiting the corresponding filter **24**, and such that its narrow end **26b** is adjacent to the corresponding detector **28**. The inward-facing surfaces of the concentrators **26** have an inner surface coating which is highly reflective and minimally absorptive in infrared wavelengths, preferably a polished gold coating. The concentrators **26** themselves may be fabricated from another rigid material such as aluminum, nickel or stainless steel, so long as their inner surfaces are coated or otherwise treated to be highly reflective.

[0117] Preferably, the concentrators **26** have a rectangular cross-section (as taken orthogonal to the longitudinal axis A-A), although other cross-sectional shapes, such as other polygonal shapes or circular, parabolic or elliptical shapes, may be employed in alternative embodiments. The inner walls of the concentrators converge as they extend toward the narrow end **26b**. Preferably, the inner walls of the collimators **26** are substantially straight and form an angle of about 8 degrees with respect to the longitudinal axis A-A. Such a configuration is adapted to concentrate infrared energy as it passes through the concentrators **26** from the wide end **26a** to the narrow end **26b**, before reaching the detectors **28**.

[0118] In a presently preferred embodiment, each concentrator **26** is about 1.5 inches in length. At the wide end **26a**, the cross-section of each concentrator **26** is a rectangle of

about 0.6 inches by 0.57 inches. At the narrow end **26b**, each concentrator **26** has a rectangular cross-section of about 0.177 inches by 0.177 inches. Of course, other dimensions or incidence angles may be employed in constructing the concentrators **26**.

#### [0119] e. Filters

[0120] The filters **24** preferably comprise standard interference-type infrared filters, widely available from manufacturers such as Optical Coating Laboratory, Inc. ("OCLI") of Santa Rosa, Calif. In the embodiment illustrated in **FIG. 1**, a 3x4 array of filters **24** is positioned above a 3x4 array of detectors **28** and concentrators **26**. As employed in this embodiment, the filters **24** are arranged in four groups of three filters having the same wavelength sensitivity. These four groups have bandpass center wavelengths of  $7.15 \mu\text{m} \pm 0.03 \mu\text{m}$ ,  $8.40 \mu\text{m} \pm 0.03 \mu\text{m}$ ,  $9.48 \mu\text{m} \pm 0.04 \mu\text{m}$ , and  $11.10 \mu\text{m} \pm 0.04 \mu\text{m}$ , respectively, which correspond to wavelengths around which water and glucose absorb electromagnetic radiation. Typical bandwidths for these filters range from 0.20  $\mu\text{m}$  to 0.50  $\mu\text{m}$ .

[0121] In an alternative embodiment, the array of wavelength-specific filters **24** may be replaced with a single Fabry-Perot interferometer, which can provide wavelength sensitivity which varies as a sample of infrared energy is taken from the material sample S. Thus, this embodiment permits the use of only one detector **28**, the output signal of which varies in wavelength specificity over time. The output signal can be de-multiplexed based on the wavelength sensitivities induced by the Fabry-Perot interferometer, to provide a multiple-wavelength profile of the infrared energy emitted by the material sample S. In this embodiment, the optical mixer **20** may be omitted, as only one detector **28** need be employed.

[0122] In still other embodiments, the array of filters **24** may comprise a filter wheel that rotates different filters with varying wavelength sensitivities over a single detector **24**. Alternatively, an electronically tunable infrared filter may be employed in a manner similar to the Fabry-Perot interferometer discussed above, to provide wavelength sensitivity which varies during the detection process. In either of these embodiments, the optical mixer **20** may be omitted, as only one detector **28** need be employed.

#### [0123] f. Detectors

[0124] The detectors **28** may comprise any detector type suitable for sensing infrared energy, preferably in the mid-infrared wavelengths. For example, the detectors **28** may comprise mercury-cadmium-telluride (MCT) detectors. A detector such as a Fermionics (Simi Valley, Calif.) model PV-9.1 with a PVA481-1 pre-amplifier is acceptable. Similar units from other manufacturers such as Graseby (Tampa, Fla.) can be substituted. Other suitable components for use as the detectors **28** include pyroelectric detectors, thermopiles, bolometers, silicon microbolometers and lead-salt focal plane arrays.

#### [0125] g. Control System

[0126] **FIG. 7** depicts the control system **30** in greater detail, as well as the interconnections between the control system and other relevant portions of the noninvasive system. The control system includes a temperature control subsystem and a data acquisition subsystem.

[0127] In the temperature control subsystem, temperature sensors (such as RTDs and/or thermistors) located in the window assembly 12 provide a window temperature signal to a synchronous analog-to-digital conversion system 70 and an asynchronous analog-to-digital conversion system 72. The A/D systems 70, 72 in turn provide a digital window temperature signal to a digital signal processor (DSP) 74. The processor 74 executes a window temperature control algorithm and determines appropriate control inputs for the heater layer 34 of the window assembly 12 and/or for the cooling system 14, based on the information contained in the window temperature signal. The processor 74 outputs one or more digital control signals to a digital-to-analog conversion system 76 which in turn provides one or more analog control signals to current drivers 78. In response to the control signal(s), the current drivers 78 regulate the power supplied to the heater layer 34 and/or to the cooling system 14. In one embodiment, the processor 74 provides a control signal through a digital I/O device 77 to a pulse-width modulator (PWM) control 80, which provides a signal that controls the operation of the current drivers 78. Alternatively, a low-pass filter (not shown) at the output of the PWM provides for continuous operation of the current drivers 78.

[0128] In another embodiment, temperature sensors may be located at the cooling system 14 and appropriately connected to the A

[0129] ID system(s) and processor to provide closed-loop control of the cooling system as well.

[0130] In yet another embodiment, a detector cooling system 82 is located in thermally conductive relation to one or more of the detectors 28. The detector cooling system 82 may comprise any of the devices disclosed above as comprising the cooling system 14, and preferably comprises a Peltier-type thermoelectric device. The temperature control subsystem may also include temperature sensors, such as RTDs and/or thermistors, located in or adjacent to the detector cooling system 82, and electrical connections between these sensors and the asynchronous A/D system 72. The temperature sensors of the detector cooling system 82 provide detector temperature signals to the processor 74. In one embodiment, the detector cooling system 82 operates independently of the window temperature control system, and the detector cooling system temperature signals are sampled using the asynchronous A/D system 72. In accordance with the temperature control algorithm, the processor 74 determines appropriate control inputs for the detector cooling system 82, based on the information contained in the detector temperature signal. The processor 74 outputs digital control signals to the D/A system 76 which in turn provides analog control signals to the current drivers 78. In response to the control signals, the current drivers 78 regulate the power supplied to the detector cooling system 14. In one embodiment, the processor 74 also provides a control signal through the digital I/O device 77 and the PWM control 80, to control the operation of the detector cooling system 82 by the current drivers 78. Alternatively, a low-pass filter (not shown) at the output of the PWM provides for continuous operation of the current drivers 78.

[0131] In the data acquisition subsystem, the detectors 28 respond to the infrared energy E incident thereon by passing one or more analog detector signals to a preamp 84. The preamp 84 amplifies the detector signals and passes them to

the synchronous A/D system 70, which converts the detector signals to digital form and passes them to the processor 74. The processor 74 determines the concentrations of the analyte(s) of interest, based on the detector signals and a concentration-analysis algorithm and/or phase/concentration regression model stored in a memory module 88. The concentration-analysis algorithm and/or phase/concentration regression model may be developed according to any of the analysis methodologies discussed herein. The processor may communicate the concentration results and/or other information to a display controller 86, which operates a display (not shown), such as an LCD display, to present the information to the user.

[0132] A watchdog timer 94 may be employed to ensure that the processor 74 is operating correctly. If the watchdog timer 94 does not receive a signal from the processor 74 within a specified time, the watchdog timer 94 resets the processor 74. The control system may also include a JTAG interface 96 to enable testing of the noninvasive system 10.

[0133] In one embodiment, the synchronous A/D system 70 comprises a 20-bit, 14 channel system, and the asynchronous A/D system 72 comprises a 16-bit, 16 channel system. The preamp may comprise a 12-channel preamp corresponding to an array of 12 detectors 28.

[0134] The control system may also include a serial port 90 or other conventional data port to permit connection to a personal computer 92. The personal computer can be employed to update the algorithm(s) and/or phase/concentration regression model(s) stored in the memory module 88, or to download a compilation of analyte-concentration data from the noninvasive system. A real-time clock or other timing device may be accessible by the processor 74 to make any time-dependent calculations which may be desirable to a user.

## [0135] 2. Analysis Methodology

[0136] The detector(s) 28 of the noninvasive system 10 are used to detect the infrared energy emitted by the material sample S in various desired wavelengths. At each measured wavelength, the material sample S emits infrared energy at an intensity which varies over time. The time-varying intensities arise largely in response to the use of the window assembly 12 (including its heater layer 34) and the cooling system 14 to induce a thermal gradient in the material sample S. As used herein, "thermal gradient" is a broad term and is used in its ordinary sense and refers, without limitation, to a difference in temperature and/or thermal energy between different locations, such as different depths, of a material sample, which can be induced by any suitable method of increasing or decreasing the temperature and/or thermal energy in one or more locations of the sample. As will be discussed in detail below, the concentration of an analyte of interest (such as glucose) in the material sample S can be determined with a device such as the noninvasive system 10, by comparing the time-varying intensity profiles of the various measured wavelengths.

[0137] Analysis methodologies are discussed herein within the context of detecting the concentration of glucose within a material sample, such as a tissue sample, which includes a large proportion of water. However, it will be evident that these methodologies are not limited to this context and may be applied to the detection of a wide variety of analytes

within a wide variety of sample types. It should also be understood that other suitable analysis methodologies and suitable variations of the disclosed methodologies may be employed in operating an analyte detection system, such as the noninvasive system **10**.

**[0138]** As shown in **FIG. 8**, a first reference signal P may be measured at a first reference wavelength. The first reference signal P is measured at a wavelength where water strongly absorbs (e.g., 2.9  $\mu\text{m}$  or 6.1  $\mu\text{m}$ ). Because water strongly absorbs radiation at these wavelengths, the detector signal intensity is reduced at those wavelengths. Moreover, at these wavelengths water absorbs the photon emissions emanating from deep inside the sample. The net effect is that a signal emitted at these wavelengths from deep inside the sample is not easily detected. The first reference signal P is thus a good indicator of thermal-gradient effects near the sample surface and may be known as a surface reference signal. This signal may be calibrated and normalized, in the absence of heating or cooling applied to the sample, to a baseline value of 1. For greater accuracy, more than one first reference wavelength may be measured. For example, both 2.9  $\mu\text{m}$  and 6.1  $\mu\text{m}$  may be chosen as first reference wavelengths.

**[0139]** As further shown in **FIG. 8**, a second reference signal R may also be measured. The second signal R may be measured at a wavelength where water has very low absorbance (e.g., 3.6  $\mu\text{m}$  or 4.2  $\mu\text{m}$ ). This second reference signal R thus provides the analyst with information concerning the deeper regions of the sample, whereas the first signal P provides information concerning the sample surface. This signal may also be calibrated and normalized, in the absence of heating or cooling applied to the sample, to a baseline value of 1. As with the first (surface) reference signal P, greater accuracy may be obtained by using more than one second (deep) reference signal R.

**[0140]** In order to determine analyte concentration, a third (analytical) signal Q is also measured. This signal is measured at an IR absorbance peak of the selected analyte. The IR absorbance peaks for glucose are in the range of about 6.5  $\mu\text{m}$  to 11.0  $\mu\text{m}$ . This detector signal may also be calibrated and normalized, in the absence of heating or cooling applied to the material sample S, to a baseline value of 1. As with the reference signals P, R, the analytical signal Q may be measured at more than one absorbance peak.

**[0141]** Optionally, or additionally, reference signals may be measured at wavelengths that bracket the analyte absorbance peak. These signals may be advantageously monitored at reference wavelengths which do not overlap the analyte absorbance peaks. Further, it is advantageous to measure reference wavelengths at absorbance peaks which do not overlap the absorbance peaks of other possible constituents contained in the sample.

**[0142]** a. Basic Thermal Gradient

**[0143]** As further shown in **FIG. 8**, the signal intensities P, Q, R are shown initially at the normalized baseline signal intensity of 1. This of course reflects the baseline radiative behavior of a test sample in the absence of applied heating or cooling. At a time  $t_c$ , the surface of the sample is subjected to a temperature event which induces a thermal gradient in the sample. The gradient can be induced by heating or cooling the sample surface. The example shown in **FIG. 8**

uses cooling, for example, using a 10° C. cooling event. In response to the cooling event, the intensities of the detector signals P, Q, R decrease over time.

**[0144]** Since the cooling of the sample is neither uniform nor instantaneous, the surface cools before the deeper regions of the sample cool. As each of the signals P, Q, R drop in intensity, a pattern emerges. Signal intensity declines as expected, but as the signals P, Q, R reach a given amplitude value (or series of amplitude values: **150**, **152**, **154**, **156**, **158**), certain temporal effects are noted. After the cooling event is induced at  $t_c$ , the first (surface) reference signal P declines in amplitude most rapidly, reaching a checkpoint **150** first, at time  $t_p$ . This is due to the fact that the first reference signal P mirrors the sample's radiative characteristics near the surface of the sample. Since the sample surface cools before the underlying regions, the surface (first) reference signal P drops in intensity first.

**[0145]** Simultaneously, the second reference signal R is monitored. Since the second reference signal R corresponds to the radiation characteristics of deeper regions of the sample, which do not cool as rapidly as the surface (due to the time needed for the surface cooling to propagate into the deeper regions of the, sample), the intensity of signal R does not decline until slightly later. Consequently, the signal R does not reach the magnitude **150** until some later time  $t_R$ . In other words, there exists a time delay between the time  $t_p$  at which the amplitude of the first reference signal P reaches the checkpoint **150** and the time  $t_R$  at which the second reference signal R reaches the same checkpoint **150**. This time delay can be expressed as a phase difference  $\Phi(\lambda)$ . Additionally, a phase difference may be measured between the analytical signal Q and either or both reference signals P, R.

**[0146]** As the concentration of analyte increases, the amount of absorbance at the analytical wavelength increases. This reduces the intensity of the analytical signal Q in a concentration-dependent way. Consequently, the analytical signal Q reaches intensity **150** at some intermediate time  $t_Q$ . The higher the concentration of analyte, the more the analytical signal Q shifts to the left in **FIG. 8**. As a result, with increasing analyte concentration, the phase difference  $\Phi(\lambda)$  decreases relative to the first (surface) reference signal P and increases relative to the second (deep tissue) reference signal R. The phase difference(s)  $\Phi(\lambda)$  are directly related to analyte concentration and can be used to make accurate determinations of analyte concentration.

**[0147]** The phase difference  $\Phi(\lambda)$  between the first (surface) reference signal P and the analytical signal Q is represented by the equation:

$$\Phi(\lambda)=|t_p-t_Q|$$

**[0148]** The magnitude of this phase difference decreases with increasing analyte concentration.

**[0149]** The phase difference  $\Phi(\lambda)$  between the second (deep tissue) reference signal R and the analytical signal Q signal is represented by the equation:

$$\Phi(\lambda)=|t_Q-t_R|$$

**[0150]** The magnitude of this phase difference increases with increasing analyte concentration.

**[0151]** Accuracy may be enhanced by choosing several checkpoints, for example, **150**, **152**, **154**, **156**, and **158** and

averaging the phase differences observed at each check-point. The accuracy of this method may be further enhanced by integrating the phase difference(s) continuously over the entire test period. Because in this example only a single temperature event (here, a cooling event) has been induced, the sample reaches a new lower equilibrium temperature and the signals stabilize at a new constant level  $I_F$ . Of course, the method works equally well with thermal gradients induced by heating or by the application or introduction of other forms of energy, such as but not limited to light, radiation, chemically induced heat, friction and vibration.

[0152] This methodology is not limited to the determination of phase difference. At any given time (for example, at a time  $t_x$ ) the amplitude of the analytical signal Q may be compared to the amplitude of either or both of the reference signals P, R. The difference in amplitude may be observed and processed to determine analyte concentration.

[0153] This method, the variants disclosed herein, and the apparatus disclosed as suitable for application of the method(s), are not limited to the detection of in-vivo glucose concentration. The method and disclosed variants and apparatus may be used on human, animal, or even plant subjects, or on organic or inorganic compositions in a non-medical setting. The method may be used to take measurements of in-vivo or in-vitro samples of virtually any kind. The method is useful for measuring the concentration of a wide range of additional chemical analytes, including but not limited to, glucose, ethanol, insulin, water, carbon dioxide, blood oxygen, cholesterol, bilirubin, ketones, fatty acids, lipoproteins, albumin, urea, creatinine, white blood cells, red blood cells, hemoglobin, oxygenated hemoglobin, carboxyhemoglobin, organic molecules, inorganic molecules, pharmaceuticals, cytochrome, various proteins and chromophores, microcalifications, hormones, as well as other chemical compounds. To detect a given analyte, one needs only to select appropriate analytical and reference wavelengths.

[0154] The method is adaptable and may be used to determine chemical concentrations in samples of body fluids (e.g., blood, urine or saliva) once they have been extracted from a patient. In fact, the method may be used for the measurement of in-vitro samples of virtually any kind.

[0155] b. Modulated Thermal Gradient

[0156] In some embodiments of the methodology described above, a periodically modulated thermal gradient can be employed to make accurate determinations of analyte concentration.

[0157] As previously shown in FIG. 8, once a thermal gradient is induced in the sample, the reference and analytical signals P, Q, R fall out of phase with respect to each other. This phase difference  $\Phi(\lambda)$  is present whether the thermal gradient is induced through heating or cooling. By alternatively subjecting the test sample to cyclic pattern of heating, cooling, or alternately heating and cooling, an oscillating thermal gradient may be induced in a sample for an extended period of time.

[0158] An oscillating thermal gradient is illustrated using a sinusoidally modulated gradient. FIG. 9 depicts detector signals emanating from a test sample. As with the methodology shown in FIG. 8, one or more reference signals J, L are measured. One or more analytical signals K are also monitored. These signals may be calibrated and normalized,

in the absence of heating or cooling applied to the sample, to a baseline value of 1. FIG. 9 shows the signals after normalization. At some time  $t_c$ , a temperature event (e.g., cooling) is induced at the sample surface. This causes a decline in the detector signal. As shown in FIG. 8, the signals (P, Q, R) decline until the thermal gradient disappears and a new equilibrium detector signal  $I_F$  is reached. In the method shown in FIG. 9, as the gradient begins to disappear at a signal intensity 160, a heating event, at a time  $t_w$ , is induced in the sample surface. As a result the detector output signals J, K, L will rise as the sample temperature rises. At some later time  $t_{c2}$ , another cooling event is induced, causing the temperature and detector signals to decline. This cycle of cooling and heating may be repeated over a time interval of arbitrary length. Moreover, if the cooling and heating events are timed properly, a periodically modulated thermal gradient may be induced in the test sample.

[0159] As previously explained in the discussions relating to FIG. 8, the phase difference  $\Phi(\lambda)$  may be measured and used to determine analyte concentration. FIG. 9 shows that the first (surface) reference signal J declines and rises in intensity first. The second (deep tissue) reference signal L declines and rises in a time-delayed manner relative to the first reference signal J. The analytical signal K exhibits a time/phase delay dependent on the analyte concentration. With increasing concentration, the analytical signal K shifts to the left in FIG. 9. As with FIG. 8, the phase difference  $\Phi(\lambda)$  may be measured. For example, a phase difference  $\Phi(\lambda)$  between the second reference signal L and the analytical signal K, may be measured at a set amplitude 162 as shown in FIG. 9. Again, the magnitude of the phase signal reflects the analyte concentration of the sample.

[0160] The phase-difference information compiled by any of the methodologies disclosed herein can be correlated by the control system 30 (see FIG. 1) with previously determined phase-difference information to determine the analyte concentration in the sample. This correlation could involve comparison of the phase-difference information received from analysis of the sample, with a data set containing the phase-difference profiles observed from analysis of wide variety of standards of known analyte concentration. In one embodiment, a phase/concentration curve or regression model is established by applying regression techniques to a set of phase-difference data observed in standards of known analyte concentration. This curve is used to estimate the analyte concentration in a sample based on the phase-difference information received from the sample.

[0161] Advantageously, the phase difference  $\Phi(\lambda)$  may be measured continuously throughout the test period. The phase-difference measurements may be integrated over the entire test period for an extremely accurate measure of phase difference  $\Phi(\lambda)$ . Accuracy may also be improved by using more than one reference signal and/or more than one analytical signal.

[0162] As an alternative or as a supplement to measuring phase difference(s), differences in amplitude between the analytical and reference signal(s) may be measured and employed to determine analyte concentration. Additional details relating to this technique and not necessary to repeat here may be found in the Assignee's U.S. patent application Ser. No. 09/538,164, incorporated by reference below.

[0163] Additionally, these methods may be advantageously employed to simultaneously measure the concentration of one or more analytes. By choosing reference and analyte wavelengths that do not overlap, phase differences can be simultaneously measured and processed to determine analyte concentrations. Although FIG. 9 illustrates the method used in conjunction with a sinusoidally modulated thermal gradient, the principle applies to thermal gradients conforming to any periodic function. In more complex cases, analysis using signal processing with Fourier transforms or other techniques allows accurate determinations of phase difference  $\Phi(\lambda)$  and analyte concentration.

[0164] As shown in FIG. 10, the magnitude of the phase differences may be determined by measuring the time intervals between the amplitude peaks (or troughs) of the reference signals J, L and the analytical signal K. Alternatively, the time intervals between the "zero crossings" (the point at which the signal amplitude changes from positive to negative, or negative to positive) may be used to determine the phase difference between the analytical signal K and the reference signals J, L. This information is subsequently processed and a determination of analyte concentration may then be made. This particular method has the advantage of not requiring normalized signals.

[0165] As a further alternative, two or more driving frequencies may be employed to determine analyte concentrations at selected depths within the sample. A slow (e.g., 1 Hz) driving frequency creates a thermal gradient which penetrates deeper into the sample than the gradient created by a fast (e.g., 3 Hz) driving frequency. This is because the individual heating and/or cooling events are longer in duration where the driving frequency is lower. Thus, the use of a slow driving frequency provides analyte-concentration information from a deeper "slice" of the sample than does the use of a fast driving frequency.

[0166] It has been found that when analyzing a sample of human skin, a temperature event of 10° C. creates a thermal gradient which penetrates to a depth of about 150  $\mu\text{m}$ , after about 500 ms of exposure. Consequently, a cooling/heating cycle or driving frequency of 1 Hz provides information to a depth of about 150  $\mu\text{m}$ . It has also been determined that exposure to a temperature event of 10° C. for about 167 ms creates a thermal gradient that penetrates to a depth of about 50  $\mu\text{m}$ . Therefore, a cooling/heating cycle of 3 Hz provides information to a depth of about 50  $\mu\text{m}$ . By subtracting the detector signal information measured at a 3 Hz driving frequency from the detector signal information measured at a 1 Hz driving frequency, one can determine the analyte concentration(s) in the region of skin between 50 and 150  $\mu\text{m}$ . Of course, a similar approach can be used to determine analyte concentrations at any desired depth range within any suitable type of sample.

[0167] As shown in FIG. 11, alternating deep and shallow thermal gradients may be induced by alternating slow and fast driving frequencies. As with the methods described above, this variation also involves the detection and measurement of phase differences  $\Phi(\lambda)$  between reference signals G, G' and analytical signals H, H'. Phase differences are measured at both fast (e.g., 3 Hz) and slow (e.g., 1 Hz) driving frequencies. The slow driving frequency may continue for an arbitrarily chosen number of cycles (in region SL<sub>1</sub>), for example, two full cycles. Then the fast driving frequency is employed for a selected duration, in region F<sub>1</sub>.

The phase difference data is compiled in the same manner as disclosed above. In addition, the fast frequency (shallow sample) phase difference data may be subtracted from the slow frequency (deep sample) data to provide an accurate determination of analyte concentration in the region of the sample between the gradient penetration depth associated with the fast driving frequency and that associated with the slow driving frequency.

[0168] The driving frequencies (e.g., 1 Hz and 3 Hz) can be multiplexed as shown in FIG. 12. The fast (3 Hz) and slow (1 Hz) driving frequencies can be superimposed rather than sequentially implemented. During analysis, the data can be separated by frequency (using Fourier transform or other techniques) and independent measurements of phase delay at each of the driving frequencies may be calculated. Once resolved, the two sets of phase delay data are processed to determine absorbance and analyte concentration.

[0169] Additional details not necessary to repeat here may be found in U.S. Pat. No. 6,198,949, titled SOLID-STATE NON-INVASIVE INFRARED ABSORPTION SPECTROMETER FOR THE GENERATION AND CAPTURE OF THERMAL GRADIENT SPECTRA FROM LIVING TISSUE, issued Mar. 6, 2001; U.S. Pat. No. 6,161,028, titled METHOD FOR DETERMINING ANALYTE CONCENTRATION USING PERIODIC TEMPERATURE MODULATION AND PHASE DETECTION, issued Dec. 12, 2000; U.S. Pat. No. 5,877,500, titled MULTICHANNEL INFRARED DETECTOR WITH OPTICAL CONCENTRATORS FOR EACH CHANNEL, issued on Mar. 2, 1999; U.S. patent application Ser. No. 09/538,164, filed Mar. 30, 2000 and titled METHOD AND APPARATUS FOR DETERMINING ANALYTE CONCENTRATION USING PHASE AND MAGNITUDE DETECTION OF A RADIATION TRANSFER FUNCTION; U.S. Provisional Patent Application No. 60/336,404, filed Oct. 29, 2001, titled WINDOW ASSEMBLY; U.S. Provisional Patent Application No. 60/340,435, filed Dec. 12, 2001, titled CONTROL SYSTEM FOR BLOOD CONSTITUENT MONITOR; U.S. Provisional Patent Application No. 60/340,654, filed Dec. 12, 2001, titled SYSTEM AND METHOD FOR CONDUCTING AND DETECTING INFRARED RADIATION; U.S. Provisional Patent Application No. 60/336,294, filed Oct. 29, 2001, titled METHOD AND DEVICE FOR INCREASING ACCURACY OF BLOOD CONSTITUENT MEASUREMENT; and U.S. Provisional Patent Application No. 60/339,116, filed Nov. 7, 2001, titled METHOD AND APPARATUS FOR IMPROVING CLINICALLY SIGNIFICANT ACCURACY OF ANALYTE MEASUREMENTS. All of the above-mentioned patents, patent applications and publications (including any appendices thereto) are hereby incorporated by reference herein and made a part of this specification.

#### [0170] B. Whole-Blood Detection System

[0171] FIG. 13 is a schematic view of a reagentless whole-blood analyte detection system 200 (hereinafter "whole-blood system") in a preferred configuration. The whole-blood system 200 may comprise a radiation source 220, a filter 230, a cuvette 240 that includes a sample cell 242, and a radiation detector 250. The whole-blood system 200 preferably also comprises a signal processor 260 and a display 270. Although a cuvette 240 is shown here, other

sample elements, as described below, could also be used in the system **200**. The whole-blood system **200** can also comprise a sample extractor **280**, which can be used to access bodily fluid from an appendage, such as the finger **290**, forearm, or any other suitable location.

[0172] As used herein, the terms “whole-blood analyte detection system” and “whole-blood system” are broad, synonymous terms and are used in their ordinary sense and refer, without limitation, to analyte detection devices which can determine the concentration of an analyte in a material sample by passing electromagnetic radiation into the sample and detecting the absorbance of the radiation by the sample. As used herein, the term “whole-blood” is a broad term and is used in its ordinary sense and refers, without limitation, to blood that has been withdrawn from a patient but that has not been otherwise processed, e.g., it has not been hemolysed, lyophilized, centrifuged, or separated in any other manner, after being removed from the patient. Whole-blood may contain amounts of other fluids, such as interstitial fluid or intracellular fluid, which may enter the sample during the withdrawal process or are naturally present in the blood. It should be understood, however, that the whole-blood system **200** disclosed herein is not limited to analysis of whole-blood, as the whole-blood system **10** may be employed to analyze other substances, such as saliva, urine, sweat, interstitial fluid, intracellular fluid, hemolysed, lyophilized, or centrifuged blood or any other organic or inorganic materials.

[0173] The whole-blood system **200** may comprise a near-patient testing system. As used herein, “near-patient testing system” is a broad term and is used in its ordinary sense, and includes, without limitation, test systems that are configured to be used where the patient is rather than exclusively in a laboratory, e.g., systems that can be used at a patient’s home, in a clinic, in a hospital, or even in a mobile environment. Users of near-patient testing systems can include patients, family members of patients, clinicians, nurses, or doctors. A “near-patient testing system” could also include a “point-of-care” system.

[0174] The whole-blood system **200** may in one embodiment be configured to be operated easily by the patient or user. As such, the system **200** is preferably a portable device. As used herein, “portable” is a broad term and is used in its ordinary sense and means, without limitation, that the system **200** can be easily transported by the patient and used where convenient. For example, the system **200** is advantageously small. In one preferred embodiment, the system **200** is small enough to fit into a purse or backpack. In another embodiment, the system **200** is small enough to fit into a pants pocket. In still another embodiment, the system **200** is small enough to be held in the palm of a hand of the user.

[0175] Some of the embodiments described herein employ a sample element to hold a material sample, such as a sample of biological fluid. As used herein, “sample element” is a broad term and is used in its ordinary sense and includes, without limitation, structures that have a sample cell and at least one sample cell wall, but more generally includes any of a number of structures that can hold, support or contain a material sample and that allow electromagnetic radiation to pass through a sample held, supported or contained thereby; e.g., a cuvette, test strip, etc. As used herein, the

term “disposable” when applied to a component, such as a sample element, is a broad term and is used in its ordinary sense and means, without limitation, that the component in question is used a finite number of times and then discarded. Some disposable components are used only once and then discarded. Other disposable components are used more than once and then discarded.

[0176] The radiation source **220** of the whole-blood system **200** emits electro-magnetic radiation in any of a number of spectral ranges, e.g., within infrared wavelengths; in the mid-infrared wavelengths; above about  $0.8 \mu\text{m}$ ; between about  $5.0 \mu\text{m}$  and about  $20.0 \mu\text{m}$ ; and/or between about  $5.25 \mu\text{m}$  and about  $12.0 \mu\text{m}$ . However, in other embodiments the whole-blood system **200** may employ a radiation source **220** which emits in wavelengths found anywhere from the visible spectrum through the microwave spectrum, for example anywhere from about  $0.4 \mu\text{m}$  to greater than about  $100 \mu\text{m}$ . In still further embodiments the radiation source emits electromagnetic radiation in wavelengths between about  $3.5 \mu\text{m}$  and about  $14 \mu\text{m}$ , or between about  $0.8 \mu\text{m}$  and about  $2.5 \mu\text{m}$ , or between about  $2.5 \mu\text{m}$  and about  $20 \mu\text{m}$ , or between about  $20 \mu\text{m}$  and about  $100 \mu\text{m}$ , or between about  $6.85 \mu\text{m}$  and about  $10.10 \mu\text{m}$ .

[0177] The radiation emitted from the source **220** is in one embodiment modulated at a frequency between about one-half hertz and about one hundred hertz, in another embodiment between about 2.5 hertz and about 7.5 hertz, in still another embodiment at about 50 hertz, and in yet another embodiment at about 5 hertz. With a modulated radiation source, ambient light sources, such as a flickering fluorescent lamp, can be more easily identified and rejected when analyzing the radiation incident on the detector **250**. One source that is suitable for this application is produced by ION OPTICS, INC. and sold under the part number NL5LNC.

[0178] The filter **230** permits electromagnetic radiation of selected wavelengths to pass through and impinge upon the cuvette/sample element **240**. Preferably, the filter **230** permits radiation at least at about the following wavelengths to pass through to the cuvette/sample elements:  $3.9 \mu\text{m}$ ,  $4.0 \mu\text{m}$ ,  $4.05 \mu\text{m}$ ,  $4.2 \mu\text{m}$ ,  $4.75 \mu\text{m}$ ,  $4.95 \mu\text{m}$ ,  $5.25 \mu\text{m}$ ,  $6.12 \mu\text{m}$ ,  $7.4 \mu\text{m}$ ,  $8.0 \mu\text{m}$ ,  $8.45 \mu\text{m}$ ,  $9.25 \mu\text{m}$ ,  $9.65 \mu\text{m}$ ,  $10.4 \mu\text{m}$ ,  $12.2 \mu\text{m}$ . In another embodiment, the filter **230** permits radiation at least at about the following wavelengths to pass through to the cuvette/sample element:  $5.25 \mu\text{m}$ ,  $6.12 \mu\text{m}$ ,  $6.8 \mu\text{m}$ ,  $8.03 \mu\text{m}$ ,  $8.45 \mu\text{m}$ ,  $9.25 \mu\text{m}$ ,  $9.65 \mu\text{m}$ ,  $10.4 \mu\text{m}$ ,  $12 \mu\text{m}$ . In still another embodiment, the filter **230** permits radiation at least at about the following wavelengths to pass through to the cuvette/sample element:  $6.85 \mu\text{m}$ ,  $6.97 \mu\text{m}$ ,  $7.39 \mu\text{m}$ ,  $8.23 \mu\text{m}$ ,  $8.62 \mu\text{m}$ ,  $9.02 \mu\text{m}$ ,  $9.22 \mu\text{m}$ ,  $9.43 \mu\text{m}$ ,  $9.62 \mu\text{m}$ , and  $10.10 \mu\text{m}$ . The sets of wavelengths recited above correspond to specific embodiments within the scope of this disclosure. Furthermore, other subsets of the foregoing sets or other combinations of wavelengths can be selected. Finally, other sets of wavelengths can be selected within the scope of this disclosure based on cost of production, development time, availability, and other factors relating to cost, manufacturability, and time to market of the filters used to generate the selected wavelengths, and/or to reduce the total number of filters needed.

[0179] In one embodiment, the filter **230** is capable of cycling its passband among a variety of narrow spectral

bands or a variety of selected wavelengths. The filter **230** may thus comprise a solid-state tunable infrared filter, such as that available from ION OPTICS INC. The filter **230** could also be implemented as a filter wheel with a plurality of fixed-passband filters mounted on the wheel, generally perpendicular to the direction of the radiation emitted by the source **220**. Rotation of the filter wheel alternately presents filters that pass radiation at wavelengths that vary in accordance with the filters as they pass through the field of view of the detector **250**.

[0180] The detector **250** preferably comprises a 3 mm long by 3 mm wide pyroelectric detector. Suitable examples are produced by DIAS Angewandte Sensorik GmbH of Dresden, Germany, or by BAE Systems (such as its TGS model detector). The detector **250** could alternatively comprise a thermopile, a bolometer, a silicon microbolometer, a lead-salt focal plane array, or a mercury-cadmium-telluride (MCT) detector. Whichever structure is used as the detector **250**, it is desirably configured to respond to the radiation incident upon its active surface **254** to produce electrical signals that correspond to the incident radiation.

[0181] In one embodiment, the sample element comprises a cuvette **240** which in turn comprises a sample cell **242** configured to hold a sample of tissue and/or fluid (such as whole-blood, blood components, interstitial fluid, intercellular fluid, saliva, urine, sweat and/or other organic or inorganic materials) from a patient within its sample cell. The cuvette **240** is installed in the whole-blood system **200** with the sample cell **242** located at least partially in the optical path **243** between the radiation source **220** and the detector **250**. Thus, when radiation is emitted from the source **220** through the filter **230** and the sample cell **242** of the cuvette **240**, the detector **250** detects the radiation signal strength at the wavelength(s) of interest. Based on this signal strength, the signal processor **260** determines the degree to which the sample in the cell **242** absorbs radiation at the detected wavelength(s). The concentration of the analyte of interest is then determined from the absorption data via any suitable spectroscopic technique.

[0182] As shown in FIG. 13, the whole-blood system **200** can also comprise a sample extractor **280**. As used herein, the term "sample extractor" is a broad term and is used in its ordinary sense and refers, without limitation, to any device which is suitable for drawing a sample material, such as whole-blood, other bodily fluids, or any other sample material, through the skin of a patient. In various embodiments, the sample extractor may comprise a lance, laser lance, iontophoretic sampler, gas-jet, fluid-jet or particle-jet perforator, ultrasonic enhancer (used with or without a chemical enhancer), or any other suitable device.

[0183] As shown in FIG. 13, the sample extractor **280** could form an opening in an appendage, such as the finger **290**, to make whole-blood available to the cuvette **240**. It should be understood that other appendages could be used to draw the sample, including but not limited to the forearm. With some embodiments of the sample extractor **280**, the user forms a tiny hole or slice through the skin, through which flows a sample of bodily fluid such as whole-blood. Where the sample extractor **280** comprises a lance (see FIG. 14), the sample extractor **280** may comprise a sharp cutting implement made of metal or other rigid materials. One suitable laser lance is the Lasette Plus® produced by Cell

Robotics International, Inc. of Albuquerque, New Mexico. If a laser lance, iontophoretic sampler, gas-jet or fluid-jet perforator is used as the sample extractor **280**, it could be incorporated into the whole-blood system **200** (see FIG. 13), or it could be a separate device.

[0184] Additional information on laser lances can be found in U.S. Pat. No. 5,908,416, issued Jun. 1, 1999, titled LASER DERMAL PERFORATOR; the entirety of this patent is hereby incorporated by reference herein and made a part of this specification. One suitable gas-jet, fluid-jet or particle-jet perforator is disclosed in U.S. Pat. No. 6,207,400, issued Mar. 27, 2001, titled NON- OR MINIMALLY INVASIVE MONITORING METHODS USING PARTICLE DELIVERY METHODS; the entirety of this patent is hereby incorporated by reference herein and made a part of this specification. One suitable iontophoretic sampler is disclosed in U.S. Pat. No. 6,298,254, issued Oct. 2, 2001, titled DEVICE FOR SAMPLING SUBSTANCES USING ALTERNATING POLARITY OF IONTOPHORETIC CURRENT; the entirety of this patent is hereby incorporated by reference herein and made a part of this specification. One suitable ultrasonic enhancer, and chemical enhancers suitable for use therewith, are disclosed in U.S. Pat. No. 5,458,140, titled ENHANCEMENT OF TRANSDERMAL MONITORING APPLICATIONS WITH ULTRASOUND AND CHEMICAL ENHANCERS, issued Oct. 17, 1995, the entire disclosure of which is hereby incorporated by reference and made a part of this specification.

[0185] FIG. 14 shows one embodiment of a sample element, in the form of a cuvette **240**, in greater detail. The cuvette **240** further comprises a sample supply passage **248**, a pierceable portion **249**, a first window **244**, and a second window **246**, with the sample cell **242** extending between the windows **244**, **246**. In one embodiment, the cuvette **240** does not have a second window **246**. The first window **244** (or second window **246**) is one form of a sample cell wall; in other embodiments of the sample elements and cuvettes disclosed herein, any sample cell wall may be used that at least partially contains, holds or supports a material sample, such as a biological fluid sample, and which is transmissive of at least some bands of electromagnetic radiation, and which may but need not be transmissive of electromagnetic radiation in the visible range. The pierceable portion **249** is an area of the sample supply passage **248** that can be pierced by suitable embodiments of the sample extractor **280**. Suitable embodiments of the sample extractor **280** can pierce the portion **249** and the appendage **290** to create a wound in the appendage **290** and to provide an inlet for the blood or other fluid from the wound to enter the cuvette **240**. (The sample extractor **280** is shown on the opposite side of the sample element in FIG. 14, as compared to FIG. 13, as it may pierce the portion **249** from either side.)

[0186] The windows **244**, **246** are preferably optically transmissive in the range of electromagnetic radiation that is emitted by the source **220**, or that is permitted to pass through the filter **230**. In one embodiment, the material that makes up the windows **244**, **246** is completely transmissive, i.e., it does not absorb any of the electromagnetic radiation from the source **220** and filter **230** that is incident upon it. In another embodiment, the material of the windows **244**, **246** has some absorption in the electromagnetic range of interest, but its absorption is negligible. In yet another embodiment, the absorption of the material of the windows **244**, **246** is not

negligible, but it is known and stable for a relatively long period of time. In another embodiment, the absorption of the windows **244**, **246** is stable for only a relatively short period of time, but the whole-blood system **200** is configured to observe the absorption of the material and eliminate it from the analyte measurement before the material properties can change measurably.

[0187] The windows **244**, **246** are made of polypropylene in one embodiment. In another embodiment, the windows **244**, **246** are made of polyethylene. Polyethylene and polypropylene are materials having particularly advantageous properties for handling and manufacturing, as is known in the art. Also, polypropylene can be arranged in a number of structures, e.g., isotactic, atactic and syndiotactic, which may enhance the flow characteristics of the sample in the sample element. Preferably the windows **244**, **246** are made of durable and easily manufactureable materials, such as the above-mentioned polypropylene or polyethylene, or silicon or any other suitable material. The windows **244**, **246** can be made of any suitable polymer, which can be isotactic, atactic or syndiotactic in structure.

[0188] The distance between the windows **244**, **246** comprises an optical pathlength and can be between about  $1\ \mu\text{m}$  and about  $100\ \mu\text{m}$ . In one embodiment, the optical pathlength is between about  $10\ \mu\text{m}$  and about  $40\ \mu\text{m}$ , or between about  $25\ \mu\text{m}$  and about  $60\ \mu\text{m}$ , or between about  $30\ \mu\text{m}$  and about  $50\ \mu\text{m}$ . In still another embodiment, the optical pathlength is about  $25\ \mu\text{m}$ . The transverse size of each of the windows **244**, **246** is preferably about equal to the size of the detector **250**. In one embodiment, the windows are round with a diameter of about  $3\ \text{mm}$ . In this embodiment, where the optical pathlength is about  $25\ \mu\text{m}$  the volume of the sample cell **242** is about  $0.177\ \mu\text{L}$ . In one embodiment, the length of the sample supply passage **248** is about  $6\ \text{mm}$ , the height of the sample supply passage **248** is about  $1\ \text{mm}$ , and the thickness of the sample supply passage **248** is about equal to the thickness of the sample cell, e.g.,  $25\ \mu\text{m}$ . The volume of the sample supply passage is about  $0.150\ \mu\text{L}$ . Thus, the total volume of the cuvette **240** in one embodiment is about  $0.327\ \mu\text{L}$ . Of course, the volume of the cuvette **240**/sample cell **242**/etc. can vary, depending on many variables, such as the size and sensitivity of the detectors **250**, the intensity of the radiation emitted by the source **220**, the expected flow properties of the sample, and whether flow enhancers (discussed below) are incorporated into the cuvette **240**. The transport of fluid to the sample cell **242** is achieved preferably through capillary action, but may also be achieved through wicking, or a combination of wicking and capillary action.

[0189] FIGS. 15-17 depict another embodiment of a cuvette **305** that could be used in connection with the whole-blood system **200**. The cuvette **305** comprises a sample cell **310**, a sample supply passage **315**, an air vent passage **320**, and a vent **325**. As best seen in FIGS. 16, 16A and 17, the cuvette also comprises a first sample cell window **330** having an inner side **332**, and a second sample cell window **335** having an inner side **337**. As discussed above, the window(s) **330**/**335** in some embodiments also comprise sample cell wall(s). The cuvette **305** also comprises an opening **317** at the end of the sample supply passage **315** opposite the sample cell **310**. The cuvette **305** is preferably

about  $\frac{1}{4}$ - $\frac{1}{8}$  inch wide and about  $\frac{3}{4}$  inch long; however, other dimensions are possible while still achieving the advantages of the cuvette **305**.

[0190] The sample cell **310** is defined between the inner side **332** of the first sample cell window **330** and the inner side **337** of the second sample cell window **335**. The perpendicular distance T between the two inner sides **332**, **337** comprises an optical pathlength that can be between about  $1\ \mu\text{m}$  and about  $1.22\ \text{mm}$ . The optical pathlength can alternatively be between about  $1\ \mu\text{m}$  and about  $100\ \mu\text{m}$ . The optical pathlength could still alternatively be about  $80\ \mu\text{m}$ , but is preferably between about  $10\ \mu\text{m}$  and about  $50\ \mu\text{m}$ . In another embodiment, the optical pathlength is about  $25\ \mu\text{m}$ . The windows **330**, **335** are preferably formed from any of the materials discussed above as possessing sufficient radiation transmissivity. The thickness of each window is preferably as small as possible without overly weakening the sample cell **310** or cuvette **305**.

[0191] Once a wound is made in the appendage **290**, the opening **317** of the sample supply passage **315** of the cuvette **305** is placed in contact with the fluid that flows from the wound. In another embodiment, the sample is obtained without creating a wound, e.g. as is done with a saliva sample. In that case, the opening **317** of the sample supply passage **315** of the cuvette **305** is placed in contact with the fluid obtained without creating a wound. The fluid is then transported through the sample supply passage **315** and into the sample cell **310** via capillary action. The air vent passage **320** improves the capillary action by preventing the buildup of air pressure within the cuvette and allowing the blood to displace the air as the blood flows therein.

[0192] Other mechanisms may be employed to transport the sample to the sample cell **310**. For example, wicking could be used by providing a wicking material in at least a portion of the sample supply passage **315**. In another variation, wicking and capillary action could be used together to transport the sample to the sample cell **310**. Membranes could also be positioned within the sample supply passage **315** to move the blood while at the same time filtering out components that might complicate the optical measurement performed by the whole-blood system **200**.

[0193] FIGS. 16 and 16A depict one approach to constructing the cuvette **305**. In this approach, the cuvette **305** comprises a first layer **350**, a second layer **355**, and a third layer **360**. The second layer **355** is positioned between the first layer **350** and the third layer **360**. The first layer **350** forms the first sample cell window **330** and the vent **325**. As mentioned above, the vent **325** provides an escape for the air that is in the sample cell **310**. While the vent **325** is shown on the first layer **350**, it could also be positioned on the third layer **360**, or could be a cutout in the second layer, and would then be located between the first layer **360** and the third layer **360**. The third layer **360** forms the second sample cell window **335**.

[0194] The second layer **355** may be formed entirely of an adhesive that joins the first and third layers **350**, **360**. In other embodiments, the second layer may be formed from similar materials as the first and third layers, or any other suitable material. The second layer **355** may also be formed as a carrier with an adhesive deposited on both sides thereof. The second layer **355** forms the sample supply passage **315**, the air vent passage **320**, and the sample cell **310**. The

thickness of the second layer **355** can be between about 1  $\mu\text{m}$  and about 1.22 mm. This thickness can alternatively be between about 1  $\mu\text{m}$  and about 100  $\mu\text{m}$ . This thickness could alternatively be about 80  $\mu\text{m}$ , but is preferably between about 10  $\mu\text{m}$  and about 50  $\mu\text{m}$ . In another embodiment, the second layer thickness is about 25  $\mu\text{m}$ .

[0195] In other embodiments, the second layer **355** can be constructed as an adhesive film having a cutout portion to define the passages **315**, **320**, or as a cutout surrounded by adhesive.

[0196] Further information can be found in U.S. patent application No. 10/055,875, filed Jan. 21, 2002, titled REAGENT-LESS WHOLE-BLOOD GLUCOSE METER. The entire contents of this patent application are hereby incorporated by reference herein and made a part of this specification.

## II. WINDOW SIGNAL CORRECTION

[0197] While the majority of the IR signal collected by the detectors **28** comes from the material sample S, IR emissions from the window assembly **12** itself can contribute approximately 10-20% of the total signal. During operation of the noninvasive system **10**, the window assembly **12** produces infrared radiation that is mixed at the detectors **28** with the infrared radiation from the material sample S. This “window signal” contribution to the total signal can reduce the sensitivity of the glucose measurement and is a major source of differential phase drift, thereby degrading the accuracy of calculations of the analyte concentration. It is therefore desirable to separate the window signal contribution from the total signal and to reduce or eliminate the window signal contribution to improve the accuracy of the analyte-concentration readings.

[0198] A. Model of the Total Signal and the Window Signal Contribution

[0199] It is helpful to construct a mathematical model of the total signal and the window signal contribution in order to reduce or eliminate the window signal contribution from the total signal.

[0200] 1. Phase Relation Between the Detector Signal and the Sample Signal

[0201] There are at least two signals impinging on each infrared detector **28** resulting in the “detector signal,” (i) the “sample signal” due to infrared radiation from the material sample S and (ii) the “window signal” due to infrared radiation from the window assembly **12**. As schematically illustrated in FIG. 18, the sum of the two infrared signals at the detector can be represented by the sum of two vectors. Defining the phase of the window signal as zero, the detector signal D(t) can be expressed as:

where

$$S = \sqrt{(A \sin \theta)^2 + (A \cos \theta + B)^2} \quad (2)$$

and

$$\tan \phi = \frac{A \sin \theta}{A \cos \theta + B} \quad (3)$$

[0202] In Equations (1)-(3),  $\omega$  is the angular frequency of the temperature cycle, S and  $\phi$  are respectively the amplitude and phase of the detector signal, A and  $\theta$  are respectively the amplitude and phase of the sample signal, and B is the amplitude of the window signal.

[0203] The phase ( $\phi$ ) measured by the detector is different from the phase ( $\theta$ ) of the sample signal. By using FIG. 18, the phase difference between the measured detector signal and window signal can be expressed as:

$$\sin(\theta - \phi) = \frac{B \sin \theta}{S} \quad (4)$$

[0204] Typically, for the noninvasive system **10**, the ratio B/S is less than or equal to approximately 0.2 and the sample signal phase ( $\theta$ ) is less than or equal to approximately 15 degrees. Therefore, the right-hand side of Equation (4) is small. Using the small-angle approximation for  $\sin(\theta - \phi)$  and rearranging terms, the basic relation of the measured detector signal phase ( $\phi$ ) to the sample signal phase ( $\theta$ ), detector signal amplitude (S), and window signal amplitude (B) can be expressed as:

$$\phi = \theta - \frac{B}{S} \sin \theta \quad (5)$$

[0205] For multiple detectors, subscripts are used to refer to each detector parameter. For detector “j” the measured detector signal phase is:

$$\phi_j = \theta_j - \frac{B_j}{S_j} \sin \theta_j \quad (6)$$

[0206] 2. Phase Change due to Analyte Concentration

[0207] Consider a two-detector system where Detector #1 is sensitive to both the sample and the analyte and the Detector #2 is sensitive to only the sample. Let the amplitude ratios remain constant throughout the measurement. The phase angles of the two sample signals at two different analyte concentrations can be expressed as:

	Detector #1	Detector #2
Concentration a	$\theta_1$	$\theta_2$
Concentration b	$\theta_1 + \delta\theta_1$	$\theta_2$

[0208] The phase differences between the two detector signals at each concentration are defined as follows:

$$\begin{aligned} \Delta\phi_a &= (\phi_1 - \phi_2)_a \\ \Delta\phi_b &= (\phi_1 - \phi_2)_b \end{aligned} \quad (7)$$

[0209] and then, using Equation (6):

$$\Delta\phi_a = (\theta_1 - \theta_2) - \left[ \frac{B_1}{S_1} \sin\theta_1 - \frac{B_2}{S_2} \sin\theta_2 \right] \quad (8)$$

and

$$\Delta\phi_b = [(\theta_1 + \delta\theta_1) - \theta_2] - \left[ \frac{B_1}{S_1} \sin(\theta_1 + \delta\theta_1) - \frac{B_2}{S_2} \sin\theta_2 \right]. \quad (9)$$

[0210] The phase change due to change in analyte concentration is very small, allowing expansion of  $\sin(\theta_1 + \delta\theta_1)$  in equation (9):

$$\Delta\phi_b = [(\theta_1 + \delta\theta_1) - \theta_2] - \left[ \frac{B_1}{S_1} (\sin\theta_1 + \delta\theta_1 \cos\theta_1) - \frac{B_2}{S_2} \sin\theta_2 \right]. \quad (10)$$

[0211] Rearranging terms and using Equation (8), the differential phase change ( $\Delta\phi_b - \Delta\phi_a$ ) between the two detector signals can be expressed as:

$$(\Delta\phi_b - \Delta\phi_a) = \delta\theta_1 \left( 1 - \frac{B_1}{S_1} \cos\theta_1 \right). \quad (11)$$

[0212] Equation (11) predicts that the differential phase change measured by the detectors due to the analyte concentration is less than the actual differential phase change ( $\delta\theta_1$ ) from the sample signal. Thus, the window signal contribution to the detector signal reduces the sensitivity of the analyte measurements.

### [0213] 3. Differential Phase Drift

[0214] When the sample and window signal amplitudes are not constant during a measurement, the phase of each detector will change. This change is not associated with a change in analyte concentration, but occurs because the ratio of the window signal amplitude (B) to the sample signal amplitude (S) is not constant. With the sample signal phases ( $\theta_1, \theta_2$ ) held constant, Equation (8) illustrates that allowing the amplitude ratios ( $B_1/S_1, B_2/S_2$ ) to vary over time results in variation of the differential phase ( $\Delta\phi$ ), which appears as a baseline drift in the detector signal.

[0215] Differential phase drift has been observed in glucose measurements from humans. FIGS. 19 and 20 illustrate typical glucose concentration data taken from a human subject with a dry arm and no coupling agent. FIG. 19 illustrates the differential phase drift, and FIG. 20 illustrates the amplitudes of the infrared and RTD signals. Because the RTD measures the temperature of the window, its amplitude should be a reasonable measure of the amplitude of the infrared signal emitted by the window. In FIG. 19, the top line shows drift in the differential phase as a function of time. The total drift is approximately 230 millidegrees. In FIG. 20, the top two lines show the relative amplitudes of the detector signals. Both signals increase approximately 25% during the measurement. The third line shows the relative amplitude of the RTD signal, which declines approximately 10%.

[0216] The data of FIGS. 19 and 20 were analyzed using the assumption that the window signal has the same value at

each detector, as does the detector signal. Under this assumption, the differential phase as a function of time can be expressed as:

$$\Delta\phi_a(t) = (\theta_1 - \theta_2) - \frac{B(t)}{S(t)} (\sin\theta_1 - \sin\theta_2) \quad (12)$$

[0217] where  $\Delta\theta_a(t)$ , B(t), and S(t) are functions of time, because the amplitudes of the window signal and the skin sample signal are changing with time. FIG. 21 illustrates the differential phase  $\Delta\theta_a(t)$  (in degrees) plotted as a function of the ratio of the RTD amplitude to the detector amplitude (S(t)). Taking the RTD amplitude as being proportional to the window signal (B(t)), FIG. 21 illustrates that the differential phase is linearly dependent on the ratio B(t)/S(t), as predicted by Equation (12).

[0218] Stabilizing the signal amplitudes from the sample and the window reduces or eliminates the time-dependent differential phase drift. This effect has been observed in measurements from water-glucose solutions where the amplitudes of the detector and RTD signals are constant throughout the measurement. Measurements from such water-glucose solutions have exhibited a reduction in the instrument's sensitivity without a differential phase drift.

[0219] However, the major source of the changing amplitudes with human subjects is the changing contact between the sample skin and the window. As the measurement proceeds, the skin conforms more closely to the window surface, thereby increasing the area of the skin in contact with the window and increasing the amplitude of the sample signal. The increased contact increases the thermal load on the window, thereby reducing the temperature swing and reducing the amplitude of the window signal. These two effects result in an overall change in the amplitude ratio B(t)/S(t) as the measurement proceeds.

[0220] The amplitude ratio for detector j can be expressed as:

$$\frac{B_j}{S_j} = \kappa_j \beta \quad (13)$$

[0221] where  $\kappa_j$  is a proportionality constant that relates the window signal amplitude at detector j to the amplitude of the RTD signal, and  $\beta$  is the ratio of the RTD signal amplitude to the detector signal amplitude.

[0222] Substituting Equation (13) into Equation (8), the differential phase drift can be expressed as:

$$\Delta\phi_a(t) - (\theta_1 - \theta_2) - \beta(t) (\kappa_1 \sin\theta_1 - \kappa_2 \sin\theta_2). \quad (14)$$

[0223] The phase angles ( $\theta_1$  and  $\theta_2$ ) each change by the same amount as a function of the contact between the sample and the window. This change of the phase angles can be expressed as:

$$\begin{aligned} \theta_1 &\rightarrow \theta_1 + \theta_c(t) \\ \theta_2 &\rightarrow \theta_2 + \theta_c(t) \end{aligned} \quad (15)$$

[0224] where  $\theta_j$  is the constant phase angle for detector j introduced by the sample, and  $\theta_c(t)$  is the phase angle change

due to the changing contact between the sample and the window. By substituting these values into Equation (14), the differential phase drift as a function of the time-varying contact can then be expressed as:

$$\Delta\phi_a(t)=\frac{(\theta_1-\theta_2)-\beta(t)[\kappa_1 \sin(\theta_1+\theta_c(t))-\kappa_2 \sin(\theta_2+\theta_c(t))]}{\theta_c(t)}. \quad (16)$$

#### [0225] 4. Reduction of the Window Signal Contribution

[0226] A number of design strategies may be employed with the noninvasive system 10 to reduce the effects of the differential phase drift from the window signal contribution on measurement accuracy. Using Equation (16) with the simplifying assumption that the proportionality constant ( $\kappa$ ) is the same for both detectors, the differential phase drift  $\Delta\phi_a(t)$  can be expressed as:

$$\Delta\phi_a(t)=\frac{(\theta_1-\theta_2)-\kappa\beta(t)[\sin(\theta_1+\theta_c(t))-\sin(\theta_2+\theta_c(t))]}{\theta_c(t)}. \quad (17)$$

[0227] By using the Identity:

$$\sin A-\sin B=2 \sin \frac{1}{2}(A-B) \cos \frac{1}{2}(A+B) \quad (18)$$

[0228] the differential phase drift can be expressed as:

$$\Delta\phi_a(t)=\frac{(\theta_1-\theta_2)-\{2\kappa \sin [\frac{1}{2}(\theta_1-\theta_2)]\beta(t) \cos [\frac{1}{2}(\theta_1+\theta_2)+\theta_c(t)]\}}{\theta_c(t)}. \quad (19)$$

[0229] The bracketed second term on the right-hand side of Equation (19) contains two factors that describe the effect of the window signal on the differential phase drift. The first factor ( $2\kappa \sin [\frac{1}{2}(\theta_1-\theta_2)]$ ) is a constant scale factor corresponding to the magnitude of the differential phase drift due to the window signal effect. The second factor corresponds to the time-dependent changes of the differential phase drift due to the window signal effect. Equation (19) suggests three ways to reduce the magnitude and time dependence of the differential phase drift due to the window effect: (i) reduce the proportionality constant  $\kappa$  by increasing the transmission of the window; (ii) minimize the quantity  $(\theta_1-\theta_2)$  by choosing filters at wavelengths having similar absorption as the sample; and (iii) minimize the change over time of  $\beta$  and  $\theta_c$  by stabilizing the physical contact between the sample S and window assembly 12.

[0230] In certain embodiments, the differential phase drift due to the window signal effect is reduced by reducing the proportionality constant  $\kappa$ . The proportionality constant  $\kappa$  relates the magnitude of the window signal at the detector to the magnitude of the RTD or heater-grid signal associated with the window's temperature oscillation. Reducing the proportionality constant  $\kappa$  can be achieved by reducing the emissivity, or, equivalently, increasing the transmission of the window, thereby reducing the magnitude of the differential phase drift due to the window signal. FIG. 22 illustrates the optical transmission of various CVD-diamond windows obtained from DeBeers Industrial Diamonds of Ascot, UK and from Norton Diamond Film of Northboro, Mass. As illustrated in FIG. 22, the window signal amplitude from the window from Norton Diamond Film is less than that of the DeBeers window.

[0231] In certain embodiments, the window effect is reduced by minimizing the quantity  $(\theta_1-\theta_2)$  by choosing filters, for analysis or reference, which transmits spectral lines that are similarly absorbed by the samples. To demonstrate this, the same subject was measured during two clinical trials (Trial A and Trial B). For both trials, the glucose detector had a 9.54 micron filter. Trial A used a reference detector with a 10.8 micron filter and Trial B used

a reference detector with a 8.5 micron filter. The table below shows the predicted values for  $\theta_1$  and  $\theta_2$ .

	Trial A	Trial B
Glucose detector (microns)	9.54	9.54
Reference detector (microns)	10.8	8.5
$(\theta_1 - \theta_2)$ (degrees)	3.7	0.6
$\sin \frac{1}{2} (\theta_1 - \theta_2)$	0.03	0.005

[0232] FIGS. 23, 24, and 25 respectively show the differential phase drift, detector signal amplitude change and detector signal phase change for continuous measurements of three measurement runs on Trial A and Trial B. As predicted, the differential phase drift is much less with Trial B even though the amplitude and phase changes of the detector signals are similar between the two trials.

[0233] In certain embodiments, the differential phase drift is reduced by stabilizing the contact between the sample S and the window assembly 12 to limit drift of the amplitude of the signals. In certain such embodiments, contact fluids are used to fill in the rough skin surface and to improve the thermal contact between the sample S and the window assembly 12. The choice of contact fluids is limited by the limitation that the contact fluid be transparent in the infrared region of the measurements. Exemplary fluids compatible with embodiments described herein includes, but are not limited to, mineral oil. Mineral oil does not completely eliminate the contact effect, since the amplitude of the skin infrared signal still increases during the measurement, although the contact effect is lessened as compared to that in the dry sample case. FIG. 26 shows the initial RTD amplitude plotted against the initial detector amplitude for a series of measurements comparing dry skin samples (in this case, human arms) with dry skin samples plus mineral oil. The spread of the initial angle is due to the initial contact condition, which changes from measurement to measurement. The differential phase drift during the measurement showed the same reduction with mineral oil.

#### [0234] B. Correction of the Window Signal Contribution

[0235] The amplitude and phase of the window signal can be subtracted in the time-domain from the detector signal to obtain the sample signal. In certain embodiments, a second signal, independent of the detector signal, provides information about the window signal amplitude and phase.

##### [0236] 1. Correction Signal

[0237] A correction signal derived from independent window signal measurements is defined as follows:

$$C_\kappa(t)=fB \cos(\omega t-\delta) \quad (20)$$

[0238] where  $f$  and  $\delta$  denote respectively the amplitude and phase deviations of the correction signal from the actual window signal. Subtracting the correction signal from the detector signal from Equation (1), the corrected detector signal  $D_\kappa(t)$  can be expressed as:

$$D_\kappa(t)=D(t)-C_\kappa(t)=A \cos(\omega t-\theta)+B[\cos(\omega t-\delta)]. \quad (21)$$

[0239] Combining the two terms in the brackets, the corrected detector signal can be expressed as:

$$D_\kappa(t)=A \cos(\omega t-\theta)+B_\kappa \cos(\omega t-\delta_\kappa) \quad (22)$$

[0240] where

$$\begin{aligned} B_k &= B\sqrt{(f\sin\delta)^2 + (1-f\cos\delta)^2} \\ &= B(1-f\cos\delta)\sqrt{1+\tan^2\delta_k} \\ \tan\delta_k &= \frac{-f\sin\delta}{1-f\cos\delta}. \end{aligned} \quad (23)$$

[0241]  $B_k$  and  $\delta_k$  are the amplitude and phase of the remaining "corrected" window signal of the corrected detector signal  $D_k(t)$ .

[0242] A time increment can be defined as:

$$\Delta T \equiv \frac{\delta_k}{\omega} \quad (24)$$

[0243] and  $D_k(t)$  at time  $(t+\Delta t)$  can be expressed as:

$$D_k(t+\Delta t) = S \cos[\omega t - (\phi - \delta_k)] = A \cos[\omega t - (\theta - \delta_k)] + B_k \cos \omega t. \quad (25)$$

[0244] Equation (25) has the same form as Equation (1) with the substitution:

$$\begin{aligned} \theta &\rightarrow \theta - \delta_k \\ \theta &\rightarrow \theta - \delta_k \end{aligned} \quad (26)$$

[0245] Substituting Equations (23) and (26) into Equation (19), the differential phase drift after correction can be expressed as a function of the parameters of the correction signal:

$$\Delta\Phi_k = (\theta_1 - \theta_2) - \left[ 2(1-f) \cos \delta \sqrt{1+\tan^2\delta_k} \sin \frac{1}{2}(\theta_1 - \theta_2) \right] - \left[ \kappa\beta(t) \cos \left[ \frac{1}{2}(\theta_1 + \theta_2) + \theta_c(t) - \delta_k \right] \right] \quad (27)$$

[0246] Using Equation (27), the maximum excursion  $\alpha\phi$  of the differential phase over a single measurement can be expressed as:

$$\alpha\phi = \left[ 2(1-f) \sqrt{1+\tan^2\delta_k} \sin \frac{1}{2}(\theta_1 - \theta_2) \right] + g(f, \delta, \beta_{\max}, \beta_{\min}, \theta_{c \max}, \theta_{c \min}) \quad (28)$$

[0247] where

$$g = \left\{ \kappa\beta_{\max} \cos \left[ \frac{1}{2}(\theta_1 + \theta_2) + \theta_{c \max} - \delta_k \right] \right\} - \left\{ \kappa\beta_{\min} \cos \left[ \frac{1}{2}(\theta_1 + \theta_2) + \theta_{c \min} - \delta_k \right] \right\} \quad (29)$$

[0248] and where  $\beta_{\max}$  is the maximum value of the amplitude ratio during a measurement,  $\beta_{\min}$  is the minimum value of the amplitude ratio during a measurement,  $\theta_{c \max}$  is the maximum value of the phase angle change due to changing contact between the sample and the window during a measurement, and  $\theta_{c \min}$  is the minimum value of the phase angle change due to changing contact during a measurement.

[0249] Equations (28) and (29) can be used to estimate the dependence of the differential phase drift on the correction signal parameters as follows:

$$\begin{aligned} g &\approx (\kappa\beta_{\max} - \kappa\beta_{\min}) \cos \left[ \frac{1}{2}(\theta_1 + \theta_2) + \frac{1}{2}(\theta_{c \max} - \theta_{c \min}) - \delta_k \right] \\ &\approx (\kappa\Delta\beta) \cos \left[ \frac{1}{2}(\theta_1 + \theta_2) + \frac{1}{2}(\theta_{c \max} + \theta_{c \min}) - \delta_k \right] \end{aligned} \quad (30)$$

[0250] and

$$\Delta\Phi \approx 2(\kappa\Delta\beta_m)(1-f) \cos \delta \sin \frac{1}{2}(\theta_1 - \theta_2) \sqrt{1+\tan^2\delta_k} \cos \left[ \frac{1}{2}(\theta_1 + \theta_2) + \frac{1}{2}(\theta_{c \max} + \theta_{c \min}) - \delta_k \right] \quad (31)$$

[0251] where  $\Delta\beta_m$  is the maximum change in the amplitude ratio over the measurement.

[0252] The upper bound for  $\Delta\Phi$  can be estimated by setting the cosine term of Equation (31) equal to one, so that:

$$\Delta\Phi \approx 2(\kappa\Delta\beta_m) \left[ \sin \frac{1}{2}(\theta_1 - \theta_2) \right] g(f, \delta) \quad (32)$$

[0253] where

$$g(f, \delta) = \left[ (1-f) \cos \delta \sqrt{1 + \left( \frac{-f\sin\delta}{1-f\cos\delta} \right)^2} \right] \quad (33)$$

[0254] The first two factors of Equation (32) depend on the change of the contact between the sample and the window, and on the absorptions of the analyte and reference spectral lines. The third factor of Equation (32), as shown in Equation (33), depends only on the parameters that correspond to how well the correction signal matches the actual window signal.

[0255] FIG. 27 illustrates a plot of  $g(f, \delta)$  as a function off for various values of  $\delta$  in millidegrees. When  $\delta$  is less than approximately 100 millidegrees,  $g$  is primarily a function of  $f$  and can be expressed as:

$$\Delta\Phi \approx 2(\kappa\Delta\beta_m) \left[ \sin \frac{1}{2}(\theta_1 - \theta_2) \right] (1-f) \quad (34)$$

[0256] where  $g \approx (1-f)$ .

[0257] The maximum excursion ( $\Delta\Phi$ ) of the differential phase drift that can be tolerated during a measurement is related to the required accuracy for the measurement. Rearranging Equation (34), the corresponding accuracy required for  $f$  can be expressed as:

$$(1-f) \leq \frac{\Delta\Phi}{2(\kappa\Delta\beta_m) \left[ \sin \frac{1}{2}(\theta_1 - \theta_2) \right]} \quad (35)$$

[0258] where  $\delta$  is less than approximately 100 millidegrees. In Equation (35),  $\Delta\beta_m$  is the change of the amplitude ratio during a measurement. The same relationship holds for the initial amplitude ratio for successive measurements, where  $(1-f)$  can be expressed as:

$$(1-f) \leq \frac{\Delta\Phi}{2(\kappa\Delta\beta_c) \left[ \sin \frac{1}{2}(\theta_1 - \theta_2) \right]} \quad (36)$$

[0259] where  $\delta$  is less than approximately 100 millidegrees and  $\Delta\beta_o$  is the change of the initial amplitude ratio for independent measurements.

[0260] The most stringent requirement on  $f$  is determined by which parameter has a larger variation,  $\Delta\beta_m$  or  $\Delta\beta_o$ . FIG. 28 illustrates the ratio of the RTD signal to the detector amplitude at the beginning of each measurement plotted against the differential phase at the beginning of each measurement for a series of dry arms measured over three days. The change in the starting amplitude ratio  $\beta$  illustrated in FIG. 28 is much larger than what is observed during a measurement. From FIG. 27, the change in  $\beta$  is approximately 80%. The typical value for  $\kappa\beta$  is around 0.2, so the change from measurement to measurement is approximately:  $\kappa\Delta\beta_o=(0.2)(0.8)=0.16$ . If the accuracy goal for the noninvasive system 10 is 5 milligrams per deciliter, at a sensitivity of 0.2 millidegrees per milligram per deciliter, this error magnitude corresponds to approximately 1 millidegree. Using 1 millidegree ( $1.7\times 10^{-5}$  radians) for  $\Delta\Phi$ , Equation (36) can be expressed as:

$$(1-f) \leq \frac{0.000054}{\left[\sin\frac{1}{2}(\theta_1-\theta_2)\right]} \quad (37)$$

[0261] FIG. 29 illustrates a plot of Equation (37), which is the desired result. FIG. 29 illustrates the accuracy needed for the amplitude of the correction signal as a function of the phase angle difference between the two spectral lines over a given range for the noninvasive system 10. In embodiments in which the noninvasive system has multiple wavelengths, the correction amplitude for the largest possible angle difference can be specified.

#### [0262] 2. Embodiments for Window Signal Correction

[0263] Certain embodiments of the window signal correction system involve obtaining a window reference signal and subtracting the window reference signal from the total signal received by the detectors. Two exemplary embodiments, as outlined below, can be used to correct the detector signal for the window signal contribution. These correction system embodiments can be implemented individually, or in cooperation with one another. Embodiments which incorporate both correction systems can advantageously use one correction system to provide a check and balance for the other correction system to ensure that extraneous signals are accurately filtered out of the final signal processed by the noninvasive system 10.

[0264] In certain embodiments, an analyte detection system 10 is used for non-invasively determining the concentration of an analyte in a sample from a sample infrared signal indicative of the analyte concentration. The detection system 10 comprises a window assembly 12 for receiving the sample infrared signal. The window assembly 12 is adapted to allow the sample infrared signal to transmit therethrough, and the window assembly 12 generates a window infrared signal. The detection system 10 further comprises at least one detector 28 configured to receive both the window infrared signal and the sample infrared signal transmitted through the window assembly. The detector 28 is adapted to generate a detector signal in response to both

the window infrared signal and the sample infrared signal. The detection system 10 further comprises a correction system in electrical communication with the detector 28. The correction system is configured to generate a corrected detector signal indicative of the concentration of the analyte in the sample.

#### [0265] a. Electrical Window Signal Correction

[0266] In certain embodiments of the “electrical window signal correction” system, the window assembly 12 comprises two types of electrical components directly connected to the window, each of which can be used to generate an electrical window reference signal. The first type of electrical component is the heater elements 38 which lie on the underside of the window. Current is applied to the heater elements 38 to heat the the window at a frequency of approximately 1 Hz for a given time to raise the temperature of the sample. The second type of electrical component is the RTDs 55 which provide signals indicative of the temperature of the window. Certain embodiments comprise a pair of RTDs 55 located generally in the center of the window, in between the heater elements 38 on the underside of the window. Other embodiments have the RTDs 55 at different positions and orientations, with the RTDs 55 not intersecting the heater elements 38 so as to avoid having the heater elements 38 undesirably impacting the RTD temperature readings. Other embodiments can use other types of electrical components which provide a signal indicative of the infrared emissions from the window assembly 12.

[0267] In certain embodiments, the correction system comprises the RTDs 55 while in other embodiments, the correction system comprises the heater elements 38. Use of the RTD signal to monitor the window signal avoids placing any other elements in the optical path, such as a mixer or filter.

[0268] Infrared radiation emitted from the window assembly 12 is a function of the temperature distribution throughout the window volume. Because an RTD 55 measures the temperature at only one spot on the window, in certain embodiments, multiple RTDs 55 are used to accurately predict the window signal. Placement of the RTDs 55 on the window assembly 12 can be chosen to allow for more accurate readings and to provide readings from various spots of the window assembly 12.

[0269] FIGS. 30A-E schematically illustrate various exemplary embodiments of the window assembly 12. In FIG. 30A, the window assembly 12 has at least one RTD 55 oriented generally parallel to the heater elements 38. In FIG. 30B, the window assembly 12 has at least one RTD 55 on the underside of a first half of the window and oriented at a non-zero angle relative to the heater elements 38 which are on the underside of a second half of the window. In FIG. 30C, the window assembly 12 has at least one RTD 55 on the underside of a first half of the window and oriented at generally perpendicularly to the heater elements 38 which are on the underside of a second half of the window. In FIG. 30D, the window assembly 12 has at least one RTD 55 on the upperside of a first half of the window and oriented at generally perpendicularly to the heater elements 38 which are on the underside of a second half of the window. In FIG. 30E, the window assembly 12 has at least one RTD 55 on the upperside of the window and oriented at a non-zero angle relative to the heater elements 38 and at least one RTD 55

on the underside of the window and oriented generally parallel to the heater elements 38.

[0270] In certain embodiments, the window reference signal is generated by a monitor configured to provide a signal indicative of the amount of current flowing through the heater elements 38. In such embodiments, the heater current measurements are generally correlated with the infrared transmissivity of the window assembly 12. In certain embodiments, the monitor directly measures the current flowing through the heater elements 38. Other embodiments measure the voltage across the heater elements 38, the resistance of the heater elements 38, or a combination of the current, voltage, or resistance parameters.

[0271] In an exemplary embodiment, a reference point is obtained by blocking out all potential infrared sources other than those directly connected to the window assembly 12. Eliminating the IR contributions from external sources can be accomplished by coating the top surface of a sample, window assembly 12 with a material with well-understood IR absorptive and reflective properties (e.g., gold or aluminum). The signals received by the detectors 28 are then specific to the window assembly 12. The detector data as a function of the heater current can then be used to characterize the IR signal generated by the window assembly 12 at different temperatures and can be appropriately subtracted from subsequent readings from an uncoated window assembly 12 to yield the IR signal generated from the sample.

[0272] FIG. 31 is a flow diagram of an embodiment of a method 500 for improving the sensitivity of a noninvasive infrared analyte detection system having a window assembly 12 and a plurality of detector channels. Each detector channel generates a detector signal in response to infrared emissions from a sample and infrared emissions from the window assembly 12. The method 500 comprises measuring a window signal for each detector channel in an operational block 510. Each window signal has a corresponding amplitude  $W_n$  and a corresponding phase delay  $\zeta_n$ . The method 500 further comprises calculating a scaling factor  $f_n$  for each detector channel in an operational block 520. Each scaling factor  $f_n$  is equal to the ratio of the corresponding window signal amplitude  $W_n$  and a normalization signal amplitude  $R$ . The method 500 further comprises determining a window reference phase shift  $\delta$  in an operational block 530. The method 500 further comprises subtracting the product of the corresponding scaling factor and a window reference signal from each detector signal in an operational block 540, thereby providing a corrected detector signal for each detector channel.

[0273] In the operational block 510, a window signal is measured for each detector channel, with each window signal having a corresponding amplitude  $W_n$  and a corresponding phase delay  $\zeta_n$ . Typically, the window signals are measured while the detector channels are maintained at an approximately stable temperature. In addition, as with detector signals in general, the window signal measurements of certain embodiments are quadrature demodulated and filtered to remove a 0.9375 Hz component.

[0274] In certain embodiments, the window signals are measured with no sample on the window assembly, while in other embodiments, the window signals are measured with a blanking sample on the window assembly. Exemplary

blanking samples compatible with embodiments described herein include, but are not limited to, non-contact black bodies (NCBB).

[0275] The phase delays  $\zeta_n$  represent the response times corresponding to each detector channel. In certain embodiments, the phase delays  $\zeta_n$  each reflect a delay between the corresponding detector channel and a selected one of the detector channels. For example, detector channel 1 can be used as the selected channel, thus having a phase delay  $\zeta_1=0$ , and the other detector channels have phase delays  $\zeta_n$  measured relative to the signal of detector channel 1. In certain embodiments, the input infrared signals received by the detector channels have approximately the same phase as one another. In certain such embodiments, this condition exists because the window assembly has an approximately constant phase over the whole area monitored by the detector channels. In other such embodiments, the detector channels each monitor the same area of the window assembly. As described more fully below, the phase delays  $\zeta_n$  are then stored in memory for use in calculating the corrected detector signals of a measurement.

[0276] In the operational block 520, a scaling factor  $f_n$  is calculated for each detector channel. Each scaling factor  $f_n$  is equal to the ratio of the corresponding window signal amplitude  $W_n$  and a normalization signal amplitude  $R$ . In certain embodiments, the normalization signal amplitude  $R$  is the amplitude of a window reference signal measured concurrently with the measurement of the window signals. In certain such embodiments, as described above, the normalization signal of certain embodiments is generated by one or more RTDs of the window assembly, while in other embodiments, the normalization signal is generated by a monitor configured to provide a normalization signal indicative of the amount of current flowing through the heater elements 38.

[0277] The set of scaling factors can be thought of as characterizing the infrared emissions from the window assembly, with each scaling factor expressed as the ratio of a window signal amplitude for each detector channel and a corresponding window reference amplitude. In certain embodiments, the window reference signal is generated with the sample on the window assembly by the same RTD which produced the normalization signal without the sample on the window assembly. As is described more fully below, the scaling factors are stored in memory so they can then be multiplied by measured window reference signals with the sample in place to provide a signal indicative of the infrared emissions from the window assembly 12.

[0278] In the operational block 530, a window reference phase shift 6 is determined. FIGS. 32A and 32 B schematically illustrate one embodiment of determining the window reference phase shift 6. In certain such embodiments, the analyte sensitivity of the analyte detection system is determined by measuring the response of the analyte detection system to known analyte concentrations. The phase difference  $\Delta\phi_n$  for a known analyte concentration is measured and plotted as a function of the analyte concentration. In certain embodiments, an average of the signals from all the detector channels is calculated for each analyte concentration, and the phase difference  $\Delta\phi_n$  is determined by subtracting a reference signal from the average of the detector signals. In certain embodiments, the reference signal is a window

reference signal measured concurrently with the measured detector signals. In such embodiments, the reference signal can be expressed as having a phase  $\theta_{ref}$  and the phase difference  $\Delta\phi_n$  is determined by subtracting  $\theta_{ref}$  from the phase of the average detector signal.

[0279] FIG. 32A schematically illustrates an exemplary plot of the measured phase difference  $\Delta\phi_n$  as a function of glucose concentration for five calibration samples with known glucose concentration levels. The slope of the line defined by these points corresponds to the glucose sensitivity of the detector channel (in units of millidegrees per milligram per deciliter).

[0280] As described above, the measured detector signals include contributions from the analyte sample and from the window assembly 12. The window signal contributions effectively reduce the sensitivity of the detector channels to analyte concentrations. Therefore, prior to calculating the slope of the measured phase difference  $\Delta\phi_n$  as a function of analyte concentration, it is desirable to subtract the window signal contribution from the measured phase difference  $\Delta 100_n$ . However, in order to use the window reference signal as a measure of the window signal contribution (i.e., the reference signal), the window reference phase shift  $\delta$  is determined.

[0281] In certain embodiments, the window reference phase shift  $\delta$  is defined to be the phase shift which yields the highest sensitivity. In such embodiments, the phase of the window reference signal is expressed as  $(\theta_{ref}+\delta)$ , and the value of  $\delta$  is varied to find the value which yields the largest slope of the phase difference versus glucose concentration. FIG. 32B schematically illustrates an exemplary plot of the sensitivity as a function of the window reference phase shift  $\delta$ . The window reference phase shift  $\delta$  which provides the highest sensitivity is then stored in memory for use as described below.

[0282] In certain other embodiments, the window reference phase shift  $\delta$  is defined to be the phase shift which results in a minimum value for the amplitude of the sample signal. Referring to FIG. 18, varying the window reference phase shift  $\delta$  effectively rotates the window signal vector B relative to the sample signal vector A. The window reference phase shift  $\delta$  is determined by selecting a detector signal S and then varying the window signal phase and subtracting B from S to minimize the sample signal amplitude A. The selected detector signal of certain embodiments is a stable and uniform signal from a calibrated glucose standard, while in other embodiments, the selected detector signal is obtained from the sample under study. The window reference phase shift  $\delta$  which provides the minimum sample signal amplitude A is then stored in memory for use as described below.

[0283] In an operational block 540, the product of the corresponding scaling factor  $f_n$  and a window reference signal is subtracted from each detector signal, thereby providing a corrected detector signal for each detector channel. In certain embodiments, a detector signal is measured from each detector channel with the sample in place on the window assembly 12 and a window reference signal is measured concurrently. The corrected detector signal for each detector channel can then be expressed as follows:

$$D_n = S_n e^{i(\theta_n + \zeta_n)} - f_n B e^{i(\theta_{ref} + \delta)}$$

[0284] where  $S_n$  is the amplitude of the measured detector signal,  $\theta_n$  is the phase of the measured detector signal, B is the amplitude of the measured window reference signal, and  $\theta_{ref}$  is the phase of the measured window reference signal. In certain embodiments, the values of  $\zeta_n$ ,  $f_n$ , and  $\delta$ , having been determined previously, are retrieved from memory.

[0285] b. Optical Window Signal Correction

[0286] As illustrated by FIG. 33, the window transmission at a wavelength of approximately 4.78 microns is low, approximately 53%. In comparison, at wavelengths of approximately 6.9 microns to approximately 12.2 microns, the window transmission is high, approximately 67%. This wavelength dependence of the window transmission is utilized in certain embodiments of the "optical window signal correction" system to measure the IR signal of the window, which includes the effects of ambient light and the temperature of the surrounding room.

[0287] FIG. 34 is a flow diagram of an embodiment of a method 600 for improving the sensitivity of a noninvasive infrared analyte detection system having a window assembly and a plurality of detector channels. Each detector channel is configured to generate signals in response to infrared emissions at a characteristic wavelength. The method 600 comprises providing a reference detector channel in an operational block 610. The reference detector channel is configured to generate reference signals in response to infrared emissions at a reference wavelength. The method 600 further comprises measuring a reference window signal using the reference detector channel in an operational block 620. The reference window signal has an amplitude corresponding to infrared emissions at the reference wavelength from the window assembly. The method 600 further comprises measuring a plurality of window signals using the plurality of detector channels in an operational block 630. Each window signal has an amplitude corresponding to infrared emissions at the characteristic wavelength of the detector channel from the window assembly. The method 600 further comprises calculating a scaling factor for each detector channel in an operational block 640. Each scaling factor is equal to the ratio of the corresponding window signal amplitude and the reference window signal amplitude. The method 600 further comprises measuring a reference detector signal using the reference detector channel in an operational block 650. The reference detector signal has an amplitude corresponding to infrared emissions at the reference wavelength from the sample and the window assembly. The method 600 further comprises measuring a plurality of detector signals using the plurality of detector channels in an operational block 660. Each detector signal has an amplitude corresponding to infrared emissions at the characteristic wavelength of the detector channel from the sample and the window assembly. The method 600 further comprises calculating a corrected detector signal for each detector channel in an operational block 670. The corrected detector signal is equal to the corresponding detector signal minus the product of the scaling factor and the reference detector signal from each detector signal.

[0288] In certain such embodiments, a 12-channel analyte detection system can be used, where the analyte detection system comprises a single window assembly and a 3x4 array of detector channels to receive the infrared signal. Each

detector channel has a corresponding filter so that each detector channel is sensitive to a particular range of wavelengths.

[0289] In the operational block 610, a reference detector channel is provided. In certain embodiments, the reference detector channel has a filter with peak absorption close to the “near IR” range (e.g., at approximately 5 microns). With reference to FIG. 33, the reference detector channel of certain embodiments has a peak absorption at approximately 4.78 microns (denoted by the bold line). Because the transmission of the window assembly 12 at this wavelength is greater than approximately 50%, the signal reaching the detector will contain appreciable signal content from the sample. However, for the purposes of certain embodiments of the method 600, measurements from this reference detector channel are treated as being indicative of infrared radiation emanating solely from the window assembly itself.

[0290] In certain embodiments, the reference detector channel is isolated from the other portions of the analyte detection system to avoid mirroring the instrument drift over time that is typical for single-test, intermittent-test, or continuous-test systems. Examples of isolation components include, but are not limited to, insulation, temperature control, or other monitoring options to ensure that the readings of the reference detector remain consistent.

[0291] In the operational block 620, the reference detector channel is used to measure a reference window signal. In certain embodiments, the reference window signal is measured with no sample on the window assembly (e.g., no arm or water on the window). In other embodiments, the reference window signal is measured with a blanking sample (e.g., NCBB) on the window assembly using a configuration similar to that used when taking readings with a sample in place. Thus, the amplitude  $A_0$  of the reference window signal corresponds to infrared emissions at the reference wavelength from the window assembly.

[0292] In the operational block 630, the plurality of detector channels are used to measure a plurality of window signals. In certain embodiments, the window signals are measured with no sample on the window assembly (e.g., no arm or water on the window). In other embodiments, the window signals are measured with a blanking sample (e.g., NCBB) on the window assembly using a configuration similar to that used when taking readings with a sample in place. In certain embodiments, the plurality of window signals are measured concurrently with the measurement of the reference window signal in the operational block 620. Thus, the amplitudes ( $A_1, A_2, A_3, \dots, A_n$ ) of the window signals correspond to infrared emissions at the corresponding wavelengths from the window assembly.

[0293] In the operational block 640, a scaling factor  $f_n$  is calculated for each detector channel. Each scaling factor  $f_n$  is equal to the ratio of the corresponding window signal amplitude and the reference window signal amplitude (i.e.,  $f_n = A_n/A_0$ ). The set of scaling factors can be thought of as characterizing the window signal contribution to the plurality of detector channels. FIG. 35 schematically illustrates the scaling factors for various wavelengths in an exemplary embodiment.

[0294] In the operational block 650, the reference detector channel is used to measure a reference detector signal. In

certain embodiments, the reference detector signal is measured with a sample (e.g., an arm of a patient) on the window assembly. Thus, the reference detector signal has an amplitude  $B_0$  corresponding to infrared emissions at the reference wavelength from the sample and the window assembly.

[0295] In the operational block 660, the plurality of detector channels are used to measure a plurality of detector signals. In certain embodiments, the plurality of detector signals are measured with a sample (e.g., an arm of a patient) on the window assembly. In certain embodiments, the plurality of detector signals are measured concurrently with the measurement of the reference detector signal. Thus, the amplitudes ( $B_1, B_2, B_3, \dots, B_n$ ) of the detector signals correspond to infrared emissions at the corresponding wavelengths from the sample and the window assembly. As described above, the window contribution dilutes the sample signal and decreases the sensitivity of the system.

[0296] In the operational block 670, a corrected detector signal amplitude is calculated for each detector channel. Each corrected detector signal amplitude is equal to the corresponding detector signal amplitude from each detector signal minus the product of the scaling factor and the reference detector signal amplitude (i.e.,  $C_n = B_n - f_n * B_0$ ). In certain embodiments, this correction is performed in the amplitude domain prior to demodulation to determine the differential phase. In such embodiments, the voltage of the  $B_0$  detector channel signal is multiplied by the scaling factor  $f_n$ , and this product is subtracted from the voltage of the detector channel signal  $B_n$ . The resultant signal  $C_n$  is then demodulated to determine the differential phase of the corrected detector signal.

[0297] FIG. 36 schematically illustrates the measured differential phase before and after performing the optical window signal correction in an exemplary embodiment. By removing the window signal contribution, the datapoints for each glucose concentration are shifted upwards. In addition, the sensitivity, given by the slope of the line through the datapoints, is higher for the corrected datapoints than for the uncorrected datapoints.

[0298] As illustrated in FIG. 36, without performing the optical window signal correction, the slope of the line is approximately 5259 milligram/deciliter/degree, corresponding to a sensitivity of approximately  $1.9 \times 10^{-4}$  degree/milligram/deciliter. After performing the optical window signal correction, the slope of the line is approximately 4296 milligram/deciliter/degree, corresponding to a sensitivity of approximately  $2.3 \times 10^{-4}$  degree/milligram/deciliter. Thus, the optical window signal correction resulted in an increase of the sensitivity of approximately 22%. As expected, the root-mean-square of the calculated lines through the two sets of datapoints are approximately equal.

[0299] FIG. 37A schematically illustrates the amplitudes of the detector signal, the sample signal, and the window signal for one of the detector channels. FIG. 37B schematically illustrates the ratio of the window signal to the sample signal. The mean ratio is approximately 23%, which matches the increase in sensitivity.

[0300] Various embodiments of the present invention have been described above. Although this invention has been described with reference to these specific embodiments, the descriptions are intended to be illustrative of the invention

and are not intended to be limiting. Various modifications and applications may occur to those skilled in the art without departing from the true spirit and scope of the invention as defined in the appended claims.

What is claimed is:

1. An analyte detection system for non-invasively determining the concentration of an analyte in a sample, the sample generating a sample infrared signal indicative of the concentration of the analyte in the sample, the detection system comprising:

a window assembly for receiving the sample infrared signal, the window assembly adapted to allow the sample infrared signal to transmit therethrough, the window assembly generating a window infrared signal;

at least one detector configured to receive both the window infrared signal and the sample infrared signal transmitted through the window assembly, the detector further adapted to generate a detector signal in response thereto; and

a correction module configured to generate a corrected detector signal indicative of the concentration of the analyte in the sample.

2. The analyte detection system of claim 1, wherein the correction module generates a correction signal indicative of the window infrared signal, and the correction module generates the corrected detector signal in response to both the correction signal and the detector signal.

3. The analyte detection system of claim 2, additionally comprising at least one resistance temperature device coupled to the window assembly.

4. The analyte detection system of claim 2, wherein the window assembly comprises a heater and at least one monitor.

5. The analyte detection system of claim 4, wherein the monitor comprises an ammeter.

6. The analyte detection system of claim 4, wherein the monitor comprises a voltmeter configured to measure a voltage across the heater.

7. The analyte detection system of claim 4, wherein the monitor comprises a resistance monitor configured to measure a resistance of the heater.

8. The analyte detection system of claim 2, additionally comprising at least one reference detector channel configured to generate the correction signal in response to infrared radiation from the window assembly.

9. A method for improving the sensitivity of a noninvasive infrared analyte detection system having a window assembly and a plurality of detector channels, each detector channel generating a detector signal in response to infrared emissions from a sample and infrared emissions from the window assembly, the method comprising:

measuring a window signal for each detector channel, each window signal having a corresponding amplitude and a corresponding phase delay;

calculating a scaling factor for each detector channel, each scaling factor equal to the ratio of the corresponding window signal amplitude and a normalization signal amplitude; and

subtracting the product of the corresponding scaling factor and a phase-shifted window reference signal from

each detector signal, thereby providing a corrected detector signal for each detector channel.

10. The method of claim 9, wherein the window signals are measured without a sample on the window assembly.

11. The method of claim 9, wherein the window signals are measured with a blanking sample on the window assembly.

12. The method of claim 9, wherein the normalization signal amplitude is measured concurrently with the measurement of the window signals.

13. The method of claim 9, wherein the normalization signal amplitude is generated by a resistance temperature device coupled to the window assembly.

14. The method of claim 9, wherein the window assembly comprises a heater and the normalization signal amplitude is indicative of a current flowing through the heater.

15. The method of claim 9, wherein determining the window reference phase shift comprises finding the value of the window reference phase shift which maximizes a sensitivity of the analyte detection system

16. The method of claim 9, wherein determining the window reference phase shift comprises finding the value of the window reference phase shift which minimizes a sample signal amplitude

17. The method of claim 9, wherein the window reference signal in measured with a sample on the window assembly.

18. A method for improving the sensitivity of a noninvasive infrared analyte detection system having a window assembly and a plurality of detector channels, each detector channel configured to generate signals in response to infrared emissions at a characteristic wavelength, the method comprising:

providing a reference detector channel, the reference detector channel configured to generate reference signals in response to infrared emissions at a reference wavelength;

measuring a reference window signal using the reference detector channel, the reference window signal having an amplitude corresponding to infrared emissions at the reference wavelength from the window assembly;

measuring a plurality of window signals using the plurality of detector channels, each window signal having an amplitude corresponding to infrared emissions at the characteristic wavelength of the detector channel from the window assembly;

calculating a scaling factor for each detector channel, each scaling factor equal to the ratio of the corresponding window signal amplitude and the reference window signal amplitude;

measuring a reference detector signal using the reference detector channel, the reference detector signal having an amplitude corresponding to infrared emissions at the reference wavelength from the sample and the window assembly;

measuring a plurality of detector signals using the plurality of detector channels, each detector signal having an amplitude corresponding to infrared emissions at the characteristic wavelength of the detector channel from the sample and the window assembly; and

calculating a corrected detector signal for each detector channel, the corrected detector signal equal to the

corresponding detector signal minus the product of the scaling factor and the reference detector signal from each detector signal.

19. The method of claim 18, wherein the reference wavelength is approximately 5 microns.

20. The method of claim 18, wherein the reference detector channel is isolated from other portions of the analyte detection system.

21. The method of claim 18, wherein the reference window signal is measured with no sample on the window assembly.

22. The method of claim 18, wherein the reference window signal is measured with a blanking sample on the window assembly.

23. The method of claim 18, wherein the plurality of window signals are measured concurrently with the measurement of the reference window signal.

24. The method of claim 18, wherein the reference detector signal is measured with a sample on the window assembly.

25. The method of claim 18, wherein the plurality of detector signals is measured with a sample on the window assembly.

26. The method of claim 18, wherein the plurality of detector signals is measured concurrently with the measurement of the reference detector signal.

27. A method of enhancing the accuracy of an analyte measuring system, wherein said analyte measuring system comprises at least one infrared radiation detector and at least one window through which infrared radiation from a sample to be tested is received, said method comprising:

estimating at least one characteristic of the detector signal produced by infrared radiation generated by said window; and

compensating the total received detector signal using at least in part said estimated characteristic.

28. A method of enhancing the accuracy of an analyte measuring system, wherein said analyte measuring system comprises at least one infrared radiation detector responsive to infrared radiation in a wavelength range and at least one window through which infrared radiation from a sample to be tested is received, said method comprising:

reducing the response of the analyte measuring system to infrared radiation emitted by the window, wherein said reducing comprises increasing the transmission of the window in the wavelength range.

29. The method of claim 28, wherein the wavelength range is between approximately 8 microns and approximately 12 microns and the transmission of the window in the wavelength range is greater than approximately 60%.

30. The method of claim 28, wherein the wavelength range is between approximately 8 microns and approximately 12 microns and the transmission of the window in the wavelength range is greater than approximately 70%.

31. A method of enhancing the accuracy of an analyte measuring system, wherein said analyte measuring system comprises a first infrared radiation detector generating a first signal having a first phase shift in response to infrared radiation in a first wavelength range, a second infrared radiation detector generating a second signal having a second phase shift in response to infrared radiation in a second wavelength range, and at least one window through which infrared radiation from a sample to be tested is received, said method comprising:

reducing the response of the analyte measuring system to infrared radiation emitted by the window, wherein said reducing comprises selecting the first wavelength range and the second wavelength range such that the first phase shift and the second phase shift are approximately equal.

32. A method of enhancing the accuracy of an analyte measuring system, wherein said analyte measuring system comprises a first infrared radiation detector generating a first signal having a first phase shift in response to infrared radiation in a first wavelength range, a second infrared radiation detector generating a second signal having a second phase shift in response to infrared radiation in a second wavelength range, and at least one window through which infrared radiation from a sample to be tested is received, said method comprising:

reducing the response of the analyte measuring system to infrared radiation emitted by the window, wherein said reducing comprises selecting the first wavelength range and the second wavelength range such that the difference between the first phase shift and the second phase shift is minimized.

33. A method of enhancing the accuracy of an analyte measuring system, wherein said analyte measuring system comprises at least one infrared radiation detector responsive to infrared radiation in a wavelength range and at least one window through which infrared radiation from a sample to be tested is received, said sample coupled to said window, said method comprising:

stabilizing the coupling between the sample and the window by placing a fluid film between the sample and the window.

34. The method of claim 33, wherein the fluid film comprises mineral oil.

\* \* \* \* \*

专利名称(译)	用于调整电子控制的红外透射窗的信号变化的方法和装置		
公开(公告)号	<a href="#">US20030146385A1</a>	公开(公告)日	2003-08-07
申请号	US10/302030	申请日	2002-11-21
[标]申请(专利权)人(译)	GABLE JENNIFER ^ h 霍尔与DALE 威特KENNETH摹 BRAIG JAMES - [R		
申请(专利权)人(译)	郑鹏 GABLE JENNIFER H. HALL W. DALE 威特KENNETH G. BRAIG JAMES R.		
当前申请(专利权)人(译)	郑鹏 GABLE JENNIFER H. HALL W. DALE 威特KENNETH G. BRAIG JAMES R.		
[标]发明人	ZHENG PENG GABLE JENNIFER H HALL W DALE WITTE KENNETH G BRAIG JAMES R		
发明人	ZHENG, PENG GABLE, JENNIFER H. HALL, W. DALE WITTE, KENNETH G. BRAIG, JAMES R.		
IPC分类号	A61B5/00 G01J1/18		
CPC分类号	A61B5/1455 A61B5/14532		
优先权	60/332322 2001-11-21 US		
其他公开文献	US6917038		
外部链接	<a href="#">Espacenet</a> <a href="#">USPTO</a>		

#### 摘要(译)

分析物检测系统非侵入性地确定样品中分析物的浓度，产生指示样品中分析物浓度的样品红外信号。检测系统包括用于接收样本红外信号的窗口组件。窗组件适于允许样品红外信号通过其传输，并产生窗口红外信号。检测系统还包括至少一个检测器，其配置成接收通过窗组件传输的窗口红外信号和样本红外信号。检测器还适于响应于此产生检测器信号。检测系统还包括校正模块，其配置成产生指示样品中分析物浓度的校正检测器信号。

