



(19) **United States**

(12) **Patent Application Publication**

(10) **Pub. No.: US 2002/0198441 A1**

Tsenkova

(43) **Pub. Date:**

Dec. 26, 2002

(54) **METHOD AND APPARATUS FOR DETECTING MASTITIS BY USING VISIBLE LIGHT RAYS AND/OR NEAR INFRARED LIGHT**

Publication Classification

(51) **Int. Cl.⁷** **A61B 5/00**; G01N 21/27; G01N 21/35; G01N 33/04
(52) **U.S. Cl.** **600/310**; 356/51; 356/300; 422/74; 422/82.09

(76) **Inventor:** Roumiana Tsenkova, Hyogo (JP)

Correspondence Address:
Robert G Mukai
Burns Doane Swecker & Mathis
PO Box 1404
Alexandria, VA 22313-1404 (US)

(57) **ABSTRACT**

A method for diagnosing mastitis of cows, includes the steps of (1) irradiating visual light rays and/or near infrared rays in a wavelength range of 400 to 2500 nm into urine, raw milk or a mammary gland of a cow, (2) detecting an intensity of transmitted light rays, reflected light rays or transmitted and reflected light rays from said urine, raw milk or mammary gland, and (3) effecting multivariate analysis while using a classification model based on probability, separability or similarity, and (4) diagnosing the presence of the mastitis of the cow.

(21) **Appl. No.:** 09/980,223

(22) **PCT Filed:** Mar. 14, 2001

(86) **PCT No.:** PCT/JP01/02017

(30) **Foreign Application Priority Data**

Mar. 31, 2000 (JP) 2000-99144

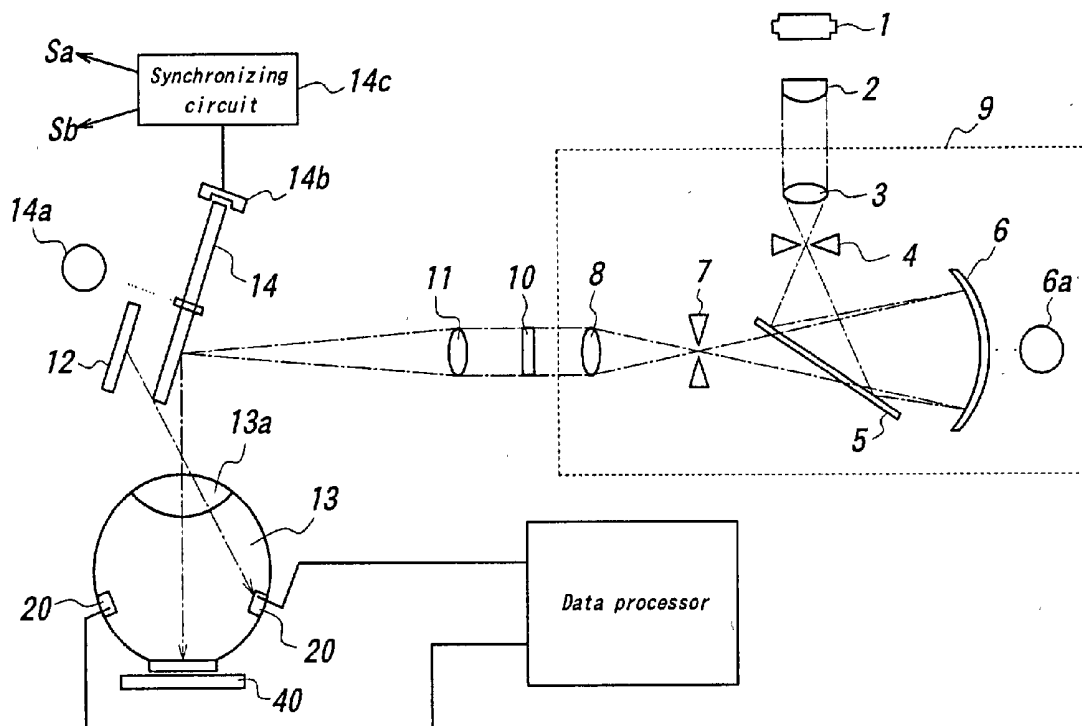

FIG. 1

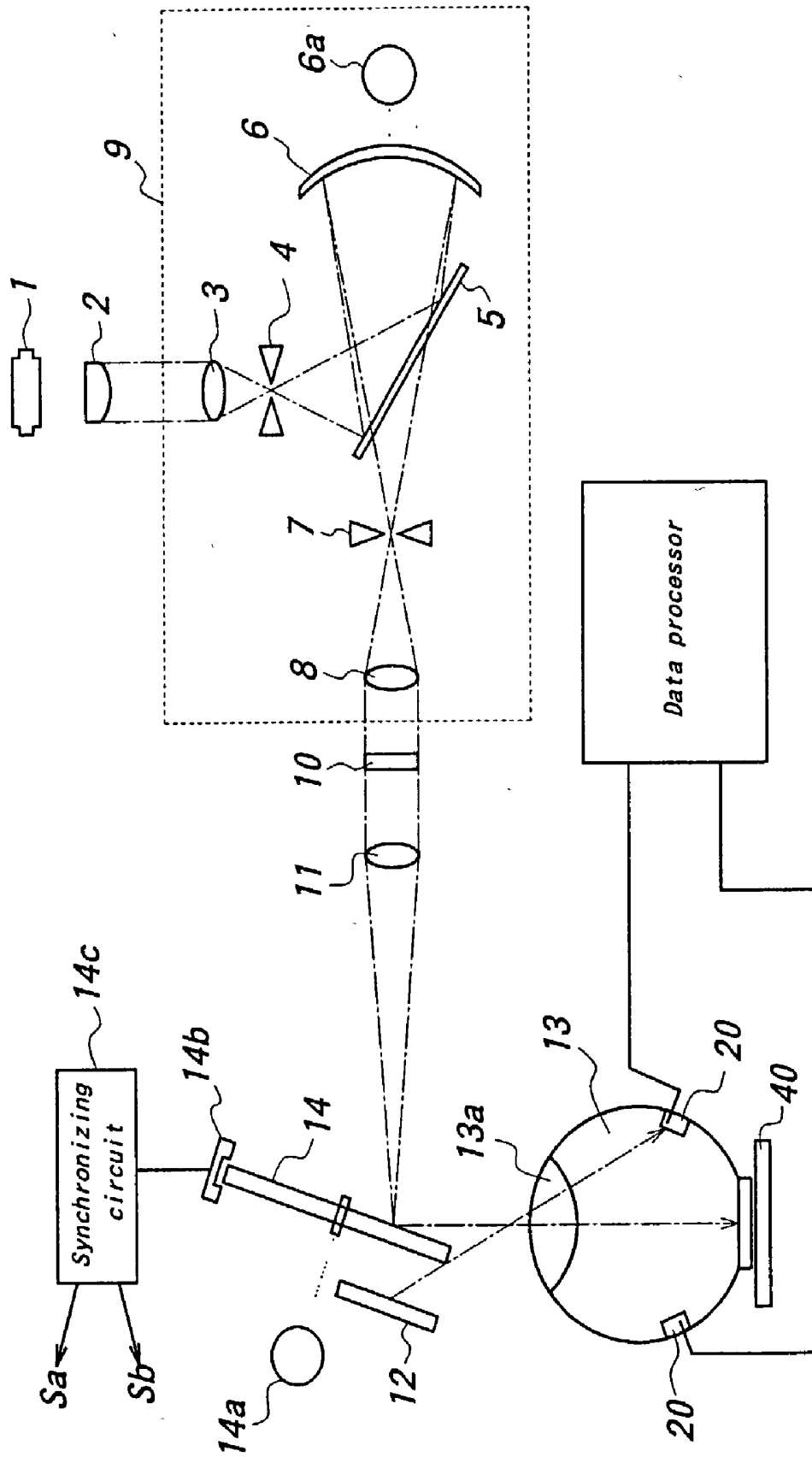

FIG. 2

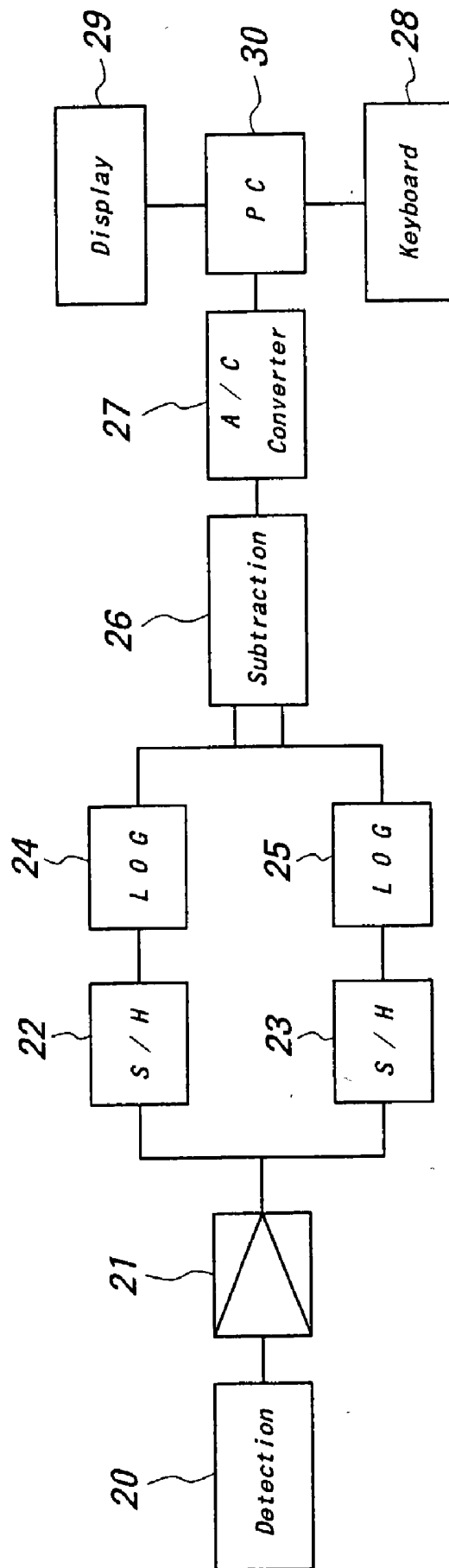

FIG. 3

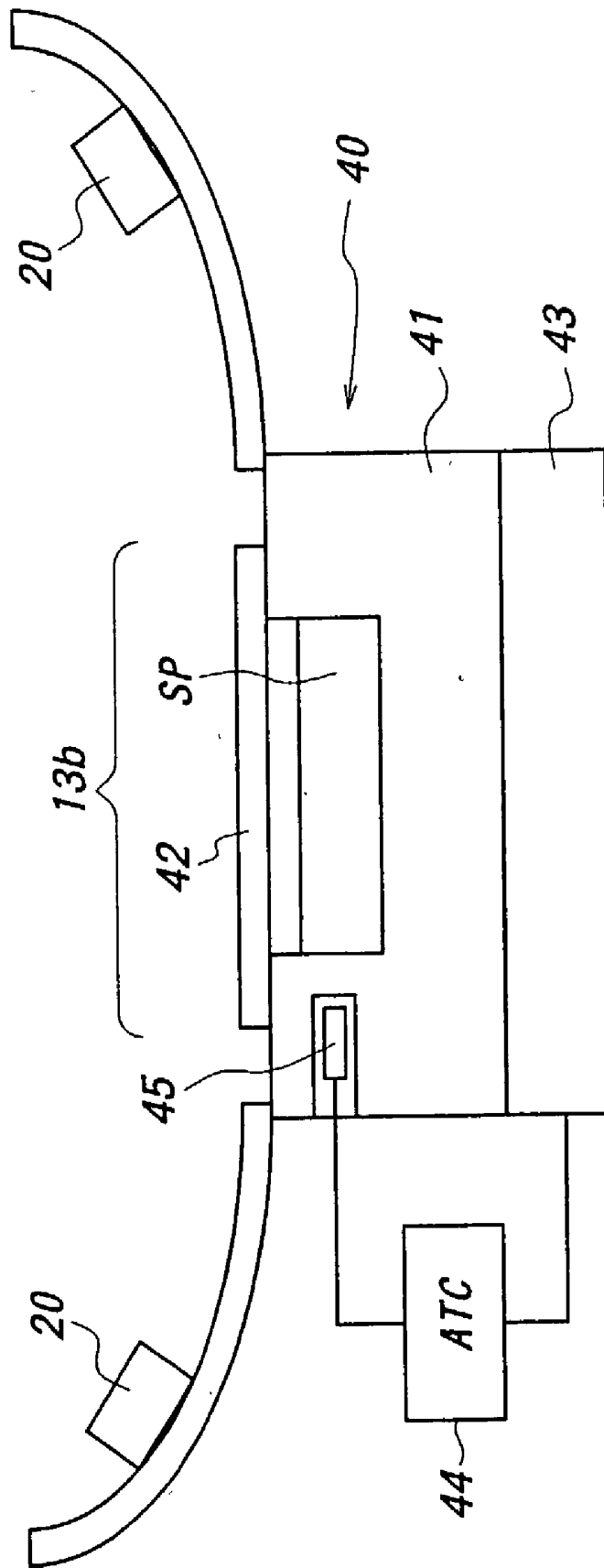

FIG. 4

VIS-NIR Spectra

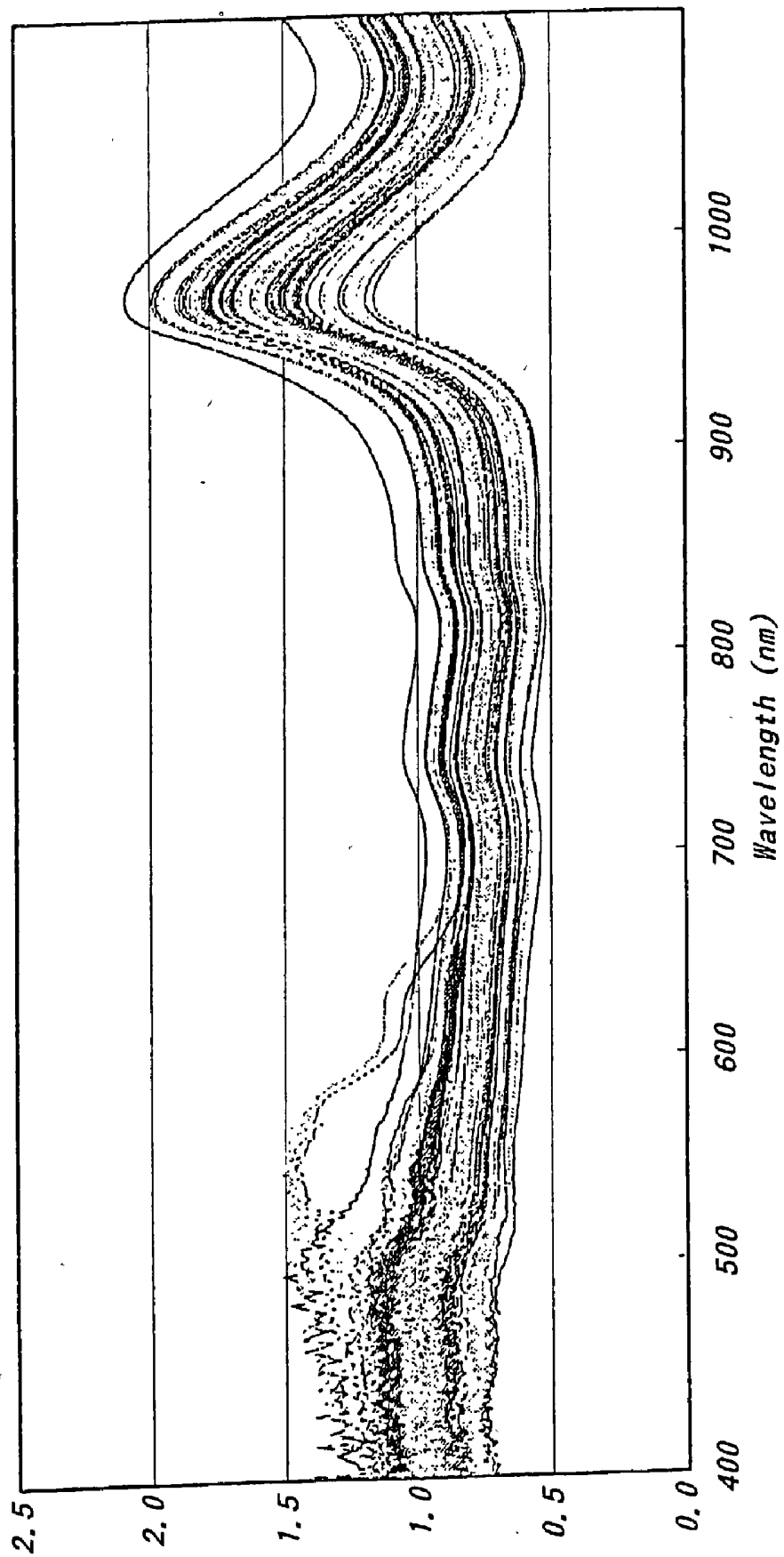

FIG. 5

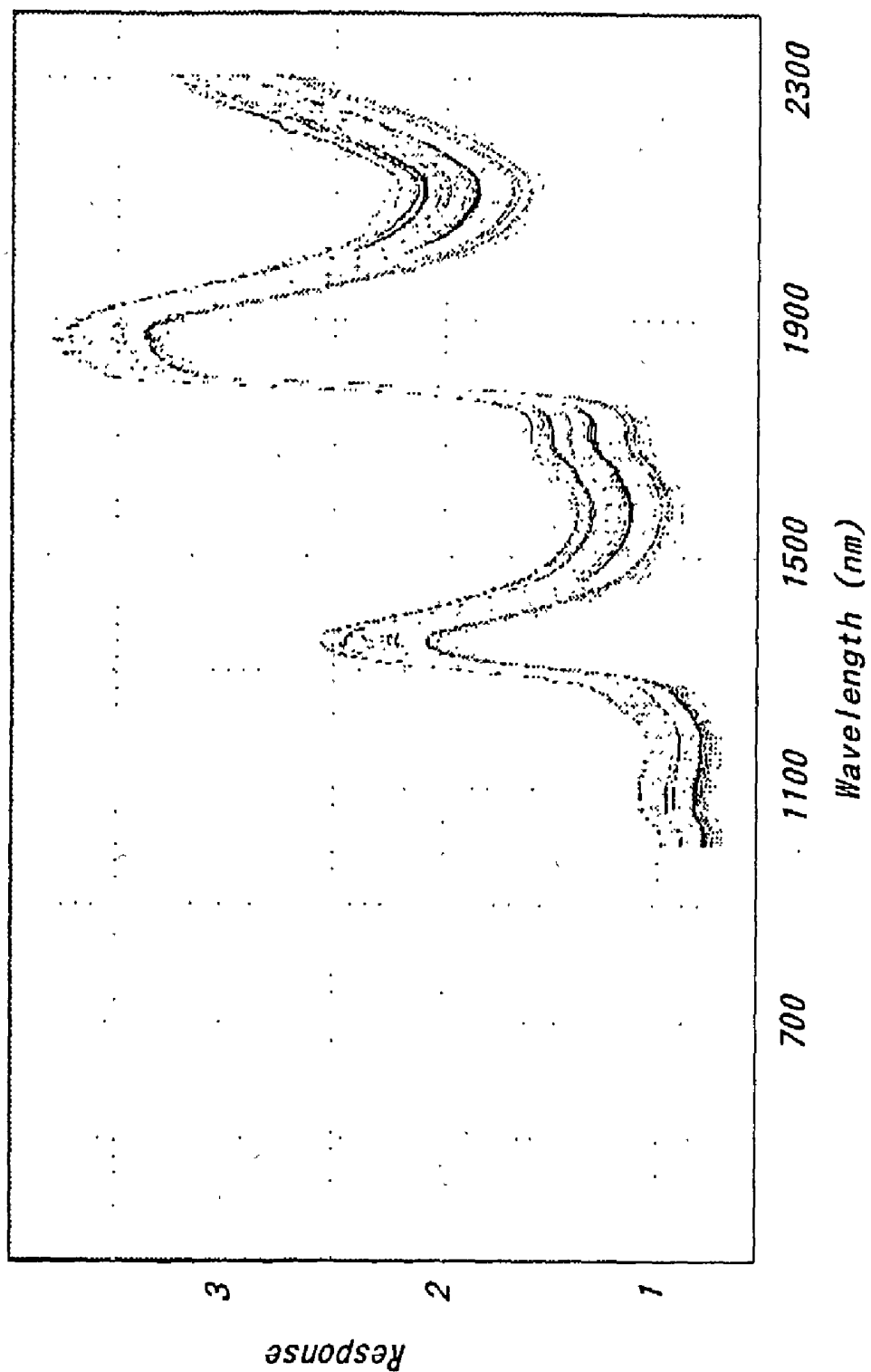

FIG. 6

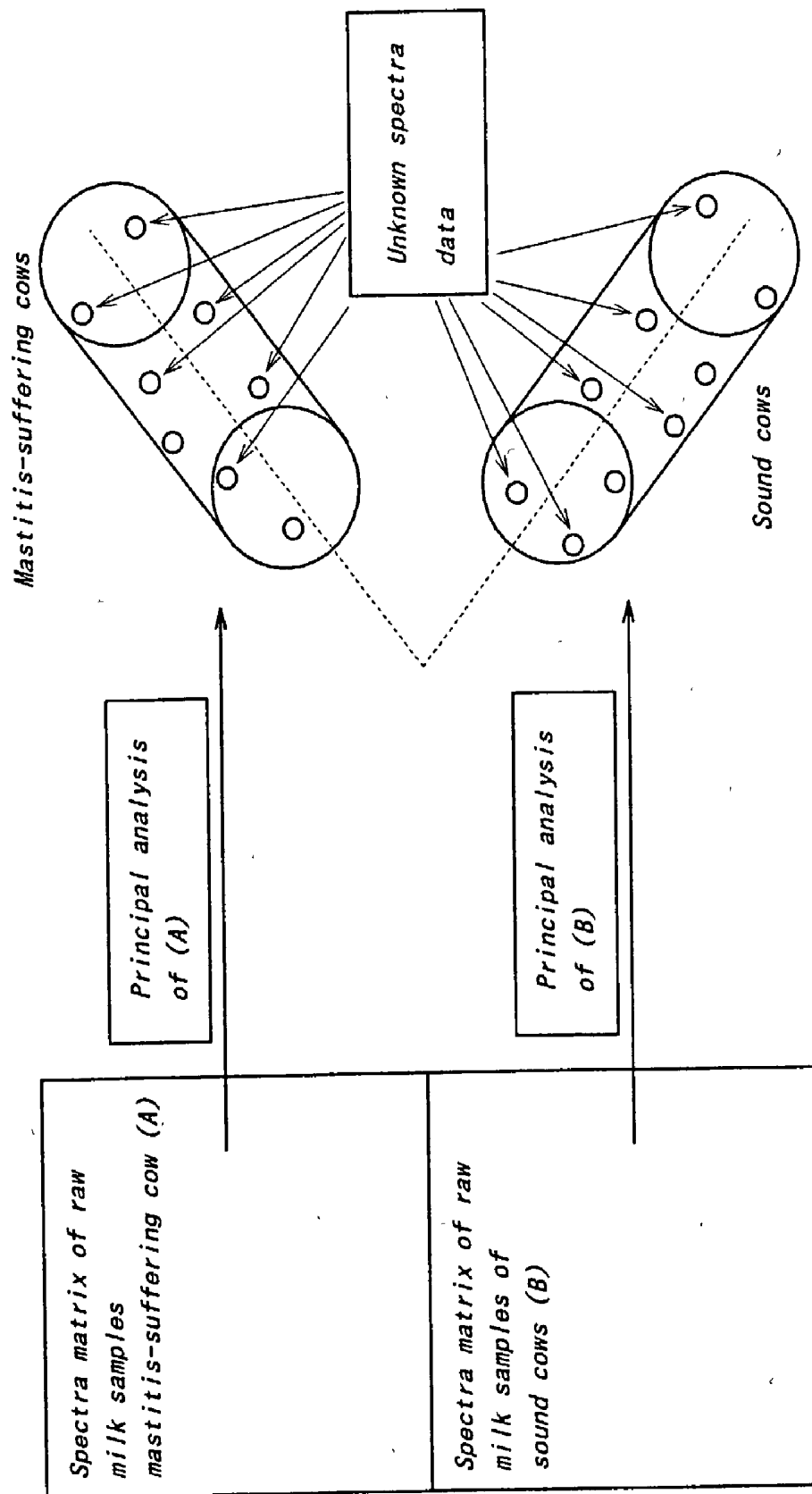
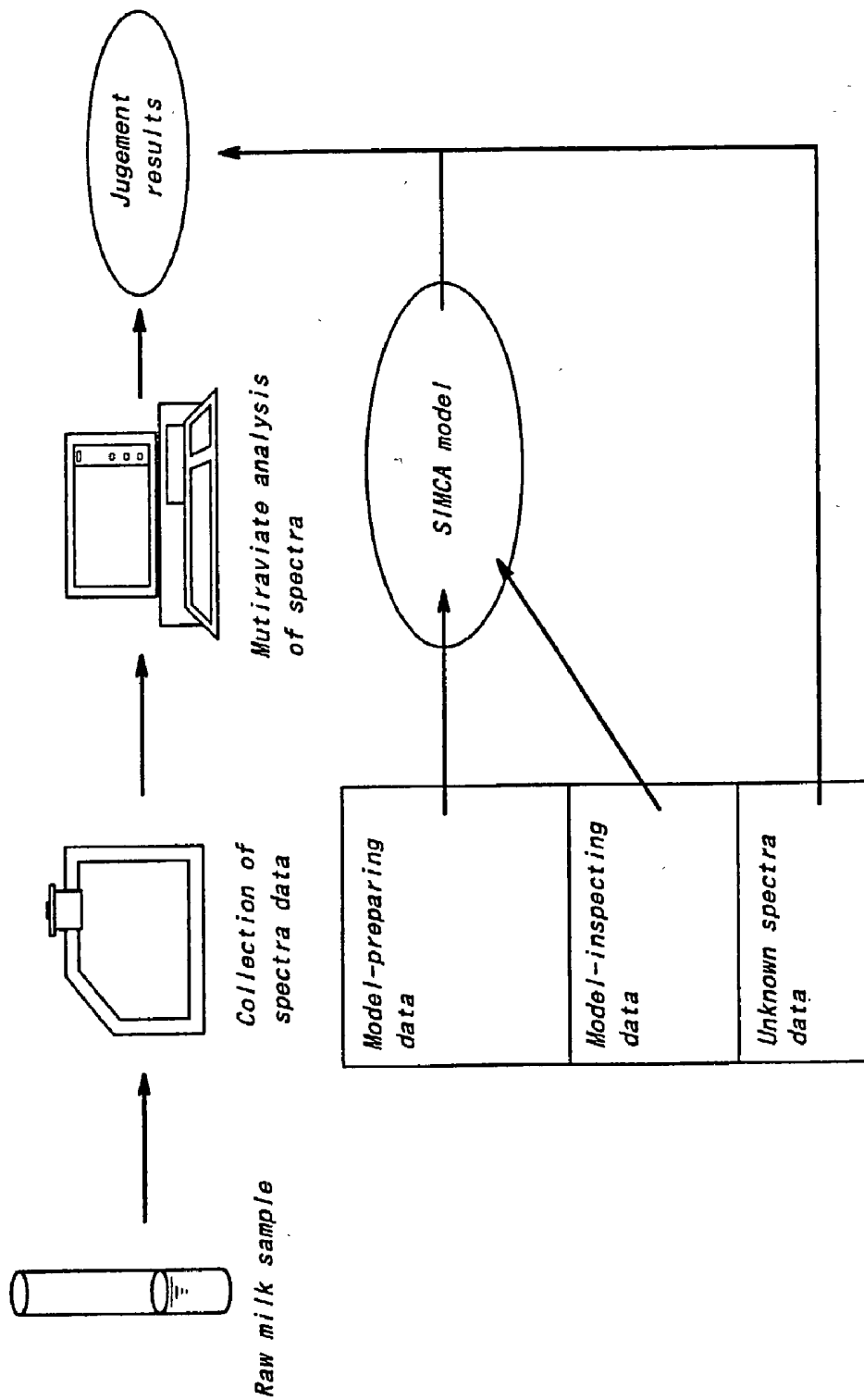

FIG. 7



METHOD AND APPARATUS FOR DETECTING MASTITIS BY USING VISIBLE LIGHT RAYS AND/OR NEAR INFRARED LIGHT

TECHNICAL FIELD TO WHICH THE INVENTION PERTAINS

[0001] The present invention relates to a method and an apparatus for diagnosing the mastitis based on visual light rays and/or near infrared rays from urine, raw milk or mammary gland of cows.

Prior Art Technique

[0002] The number of somatic cells in raw milk is an important factor for the mastitis diagnosis. Heretofore, a direct microscopy method, a CMT modified method, and a coal counter have been used for measuring the number of the somatic cells.

[0003] At present, a fluorometrical type somatic cell counter (Fossomatic) is used to measure the number of the somatic cells in the raw milk. This apparatus can calculate and display the number of the somatic cells per 1 ml through mixing a buffer solution and a dying liquid (ethidium bromide solution) to the raw milk, fluorescently staining cell nuclei of the somatic cells, scatteredly applying the resulting mixture to a peripheral portion of a disc continuously rotated with use of a microsyringe, and automatically measuring the number of the somatic cells with the fluorescent microscope.

[0004] In Japan, it is prescribed that if the number of the somatic cells is 300,000 or more per 1 ml in the measurement of the raw milk with the fluorometrical type somatic cell counter, the cow is judged to suffer the mastitis, and prohibited from being milked.

PROBLEMS TO BE SOLVED BY THE INVENTION

[0005] However, the conventional mastitis diagnosis method based on the measurement of the somatic cells with the fluorometrical type somatic cell counter has various problems to be solved, in that (1) the raw milk taken needs to be subjected to preliminary treatment with the addition of chemicals such as the buffer solution and the dying liquid; (2) the raw milk sample cannot be measured in a non-destructive manner; (3) the raw material is likely to be influenced with another substance; (4) the prices of the chemicals are high, which is disadvantageous from the standpoint of the cost performance; and (5) skillful technical [method is required to handle the apparatus and the sample.

[0006] It is an object of the present invention to provide a measuring method and apparatus and a judgment method therefor, which perform the diagnosis of the mastitis at a high precision in a short time through the optical measurement of the visual light rays and/or near infrared spectra from urine, raw milk or a mammary gland of a cow.

MEASURES TO SOLVE THE PROBLEMS

[0007] The present invention relates to the method for diagnosing mastitis of cows, comprising the steps of irradiating visual light rays and/or near infrared rays in a wavelength range of 400 to 2500 nm into urine, raw milk or a mammary gland of a cow, detecting an intensity of transmitted light rays, reflected light rays or transmitted and

reflected light rays from said urine, raw milk or mammary gland, effecting multivariate analysis by using a classification model based on probability, separability or similarity, and diagnosing the presence of the mastitis of the cow. With respect to the visual light rays and/or the near infrared rays to be used for the detection, those in a wavelength judged effective for the diagnosis of the mastitis are selected. The intensity of the light rays, etc. reflected from the mammary gland means the intensity of the reflected light rays, etc. from the tissues of the living body including mammal cells. As to the measurement of the transmitted light rays, the incident light rays are applied to a right side of the mammary gland through an optical fiber, and the transmitted light rays (on a side of the detector) are measured through another optical fiber applied to a left side of the mammary gland, while the optical fiber is applied to a left side. The light rays in the near infrared range pass an even thick mammary gland depending upon the wavelength range.

[0008] According to the present invention, the absorbance, which varies depending upon the number of the somatic cells in urine, raw milk or mammary gland, can be determined by detecting the intensity of the transmitted light rays, reflected light rays or transmitted and reflected light rays from the urine, raw milk or mammary gland of the cow. Thus, the mastitis of the cow can be diagnosed by performing the multivariate analysis using the thus obtained classification model based on probability, separability or similarity, and diagnosing the presence of the mastitis of the cow. Therefore, it is no need to effect the conventionally troublesome pretreatments, to use expensive chemicals, etc. and to skillfully handling samples.

[0009] The wavelength of the visual light rays and the near infrared rays to be used for the diagnosis of the mastitis in the present invention ranges from 400 nm to 2500 nm. If the visual light rays and the infrared rays in a range of 400 nm to 1100 nm are used, a silicon light detector is used. If the near infrared rays in the wavelength range of 700 nm to 2500 nm are used, a light detector of such as a PbSe, InGaAs or GaAs is used.

[0010] Since the visual light rays and the near infrared ray in the range of 400 nm to 700 nm have noises it is preferable to use the near infrared rays in the range of 700 to 2500 nm among the above-mentioned wavelength range of the visual light rays and the near infrared rays. Further, since the raw milk contains various ingredients such as water, proteins, fat, carbohydrates, minerals, etc. and light rays are absorbed principally by water as the main ingredient at various wavelength regions, it may be feared that such will interrupt the measurement of the near infrared spectra. However, the water-related influence is smaller in the wavelength region of 700 to 2500 nm as compared with those in the other wavelength region. In the wavelength region of 1100 to 2500 nm, changes in the absorbance of the somatic cells in the urine, raw milk or mammary gland appear as first harmonic tone or combination tone of molecular vibrations. Therefore, the measurement is preferably made with the near infrared rays in the wavelength range of 1100 nm to 2500 nm, which enables measurement of the somatic cells in the urine, raw milk or mammary gland in a short time.

[0011] Moreover, since the intensity of the light absorption in the urine, raw milk or mammary gland is relatively small in the wavelength region of the infrared rays, the thickness

of the sample can be ensured at a few or several mm in the measurement of the transmitted light rays or the transmitted and reflected light rays. Therefore, it is easy to handle and set a sample container.

[0012] The mastitis of the cows can be readily diagnosed at high precision through the optical measurement of the urine, raw milk or mammary gland and the data processing based on the multivariate analysis by utilizing a classification model based on probability, separability or similarity. The method for the diagnosis of the cow mastitis, which uses the optical measurement values for the urine, raw milk or mammary gland and the multivariate data processing utilizing the classification model based on probability, separability or similarity, will be explained later.

[0013] The present invention is characterized in that the incident light rays, transmitted light rays, reflected light rays or transmitted and reflected light rays from the urine, raw milk or mammary gland in the optical measurement is scanned over the wavelengths by using a spectroscope, and the multivariate analysis using the classification model based on the probability, separability or similarity is applied to the spectra obtained.

[0014] According to the present invention, since substantially continuous spectra having a high wavelength resolution can be obtained through scanning over the wavelengths with use of the spectroscope, such a large amount of data as required for the data analysis can be obtained. For example, if the scanning is effected in the wavelength region of 1100 to 2500 nm at a wavelength resolution of 2 nm, 701 data can be taken in per one scanning, resulting in enhanced precision of the data analysis.

[0015] The present invention also relates to the apparatus for diagnosing mastitis of cows, comprising: (1) a near infrared ray generator for generating visual light rays and/or near infrared rays in a wavelength range of 400 nm to 2500 nm; (2) an optical system for introducing the visual light rays and/or near infrared rays into urine, raw milk or a mammary gland of a cow; (3) a detector for detecting an intensity of transmitted light rays, reflected light rays or transmitted and reflected light rays from said urine, raw milk or mamma; (4) and a data processor for receiving signals from said detector, and effecting multivariate analysis by using a classification model based on probability, separability or similarity to diagnose the presence of the mastitis of the cow.

[0016] The mastitis diagnosis apparatus according to the present invention preferably further comprises an optical fiber for leading visual light rays and/or near infrared rays from said urine, raw milk or a mammary gland of the cow to the light detector, so that the intensity of transmitted light rays, reflected light rays or transmitted and reflected light rays from said urine, raw milk or mammary gland is detected with said detector through the optical fiber.

[0017] The utilization of the optical fiber can provide the portable, compact mastitis diagnosis apparatus.

[0018] The cow mastitis-diagnosing apparatus preferably further comprises a feeder for introducing said raw milk into a raw milk sample container via an in-line or at line.

[0019] The provision of the feeder for introducing said raw milk into the sample container via an in-line or at line

enables the continuous measurement of the visual light rays and/or near infrared rays with the lapse of time.

[0020] The cow mastitis-diagnosing apparatus further comprises a sample container for holding the raw milk, and a temperature controller for stabilizing the milk inside the sample container to a given temperature. When the mammary gland is to be measured, it is held with a milking machine, and the temperature is controlled in the same way as mentioned above, if necessary.

[0021] Stabilization of the temperature of the raw milk in the sample container can prevent variations in absorbance of the raw milk due to temperature, which can enhance the precision in the diagnosis of the mastitis.

[0022] The spectra for the mammary gland means the spectra of the light rays from the living tissues including the mammary gland cells. It is considered that mammary gland cells (including the raw milk) and the living tissues are milky and cuvette, respectively, in the mammary gland.

BRIEF DESCRIPTION OF THE DRAWINGS

[0023] FIG. 1 is a construction view of a raw milk spectra-measuring apparatus as one embodiment of the present invention.

[0024] FIG. 2 is a block diagram constituting an example of an electric construction of the raw milk spectra-measuring apparatus.

[0025] FIG. 3 is a sectional view of a sample holder 40.

[0026] FIG. 4 is a graph showing an example of near infrared ray spectra of a number of raw milk samples in a wavelength range of 400 nm to 1100 nm.

[0027] FIG. 5 is a graph showing an example of near infrared ray spectra of a number of raw milk samples in a wavelength range of 1100 nm to 2500 nm.

[0028] FIG. 6 is a figure for illustrating a procedure for performing a SIMCA method as one form of multivariate analyses using a classification model based on probability, separability or similarity according to the present invention.

[0029] FIG. 7 is a figure for illustrating the entire procedure for performing the SIMCA (Soft Independent Model of Class Analogy) method as one form of a multivariate analysis using a classification model based on probability, separability or similarity according to the present invention.

EMBODIMENTS OF WORKING THE PRESENT INVENTION

[0030] The mastitis-diagnosing apparatus according to the present invention will be explained with reference to FIG. 1.

[0031] FIG. 1 is a construction view of a raw milk spectra-measuring apparatus as one embodiment of the present invention. As viewed in the light-progressing direction, this apparatus comprises a light source for generating measuring light rays, a lens 2 for making light rays from the light source 1 in parallel to one another, a spectroscope 9 for taking out desired light rays through separating the light rays from the light source 1, a filter 10 for cutting off a high light portion of the light rays emitted from the spectroscope, a lens 11 for collecting the separated light rays, a reflection

mirror 12 for reflecting the light rays from the lens 11, a light chopper 14 interposed between the lens 11 and the reflection mirror 12, an integrating sphere 132 formed of a light-diffusing material, a sample holder 40 for holding a sample, etc.

[0032] The light source 1 is constituted by a tungsten halogen lamp or the like, which generates a wide wavelength range of the light rays including near infrared rays. The spectroscopy 9 comprises a lens 3 for collecting the incident light rays, a slit 4 for regulating the size and the amount of the light ray flux, a reflection mirror 5 for reflecting the light rays having passed the slit 4, a diffraction grating 6 having a curved surface, a motor 6a for controlling the diffraction angle of the diffraction grating 6, a slit 7 for passing only a desired light portion among the light rays diffracted at the diffraction grating 6, a light-emitting lens 8 for emitting the diffracted light rays in parallel to one another, etc. Only the light rays with the desired wavelength can be selectively taken out by the angular controlling with the motor 6a.

[0033] The light chopper 14 is designed in the form of a rotary disc in which light-reflecting sections and light-permeating sections are alternatively arranged, and the light rays coming from the lens 11 is periodically reflected or passed by rotating the optical chopper 14 through driving a motor 14a. A chopper sensor 14b detects the rotary phase of the light chopper 14, and a synchronizing circuit 14c outputs synchronizing signals Sa and Sb indicative of the reflected and passing states for the light rays from the lens 11, respectively, based on the signals from the chopper sensor 14b.

[0034] The integrating sphere 13 comprises an incident light window 13a opened upwardly, a light-emitting window 13b opened downwardly, and plural light detectors 20 for converting amounts of received light rays to electric signals. The integrating sphere 13 functions to diffuse the light rays entering the sphere to reduce measurement errors. The detector 20 is constituted by PbS or the like, which has a sensitivity in the near infrared ray region. The sample holder 40 is arranged near the light-emitting window 13b.

[0035] If the light rays, which are separated by the spectroscopy 9, are reflected with the light chopper 14, the light rays come into the sample holder 40 as it is through the integrating sphere 13 via the incident light window 13a. As a result, return light rays diffuse in the integrating sphere 13, so that a part of the light rays are received with the light detectors 20. On the other hand, if the light rays separated with the spectroscopy 9 passes the light chopper 14, the light rays are reflected with the reflection mirror 12, so that the light rays enter obliquely into the integrating sphere 13 via the incident light window 13a. Consequently, the light rays are diffused without reaching the sample, and a part of that light rays are received by the light detector 20. The above operation of the chopper takes out signals influenced with the sample and those not influenced with the sample.

[0036] FIG. 2 is an example of a block diagram showing an electric construction of the data processor of the raw milk spectra-measuring apparatus. Detection signals from light detectors 20 are amplified with an amplifier 21, and inputted to a sample holding circuit 22 for sampling with synchronizing signals Sa and a sample holding circuit 23 for sampling with synchronizing signals Sb. The sample holding circuit 22 holds a signal voltage only during a sampling

time period when the light rays enter the sample from the spectroscopy 9, whereas the sample holding circuit 23 holds the electric signals only during the sampling time period when the light rays do not enter the sample from the spectroscopy 9. Then, output signals from the sample holding circuits 22 and 23 are logarithmically converted with logarithmically converting circuits 24, 25 respectively, which are subjected to subtraction between them in a subtraction circuit 26. Disturbance components can be removed through detection in synchronization with the light chopper 14.

[0037] Output signals from the subtraction circuit is quantized with an AD (analogue/digital) converter 27, which is led into a personal computer (PC) 30 in which various programs are installed to effect data processing according to the SIMCA method. To the PC 30 are connected a keyboard 28 for inputting data, a display 29 for displaying the data, etc.

[0038] FIG. 3 is a sectional view showing the construction of a sample holder 40. This sample holder 40 fits to the configuration of the light-emitting window 13b of the integrating sphere 13. The sample holder, which is made of a heat-conductive material such as aluminum, comprises a sample container 41 for holding a liquid sample SP such as a raw milk, a transparent cover glass plate 42 for covering an opening of the sample container 41, a Peltier element for heating or cooling the sample container 41, a temperature sensor 45 for controlling the temperature of the sample container 41, a temperature-controlling circuit 44 for stabilizing the temperature of the sample SP by driving the Peltier element based on temperature signals from the temperature sensor 45, etc.

[0039] When the light rays reflected from the light chopper 14 enter the sample SP via the cover glass plate 42, they return into the integrating sphere 13 again after being attenuated and scattered depending upon the absorption spectra of the sample SP. Consequently, a part of the returned light rays are received by the light detector 210 where they are converted to electric signals.

[0040] Since the absorbance of the raw milk is sensitive to changes in temperature and less influence of fat in the raw milk has to be achieved, significance of the measurement may be lost if the measurement environmental temperature changes every measurement. Thus, according to this embodiment, the temperature of the sample SP is stabilized by the temperature feed-back system constituted by the temperature sensor 45, the temperature-controlling circuit 44 and the Peltier element 43, thereby enhancing the measuring precision.

[0041] FIG. 4 is a graph showing an example of near infrared spectra of the raw milk wherein an ordinate gives absorbances represented by figures obtained by logarithmically converting reciprocals of light reflectances, and an abscissa denotes wavelengths (nm). A curve corresponds to an absorption spectra obtained by scanning over a wavelength of 400 nm to 1100 nm with use of the spectroscopy 9 in FIG. 1. In FIG. 4, results obtained by measuring plural raw milk samples are displayed in an overlapped state. FIG. 5 is also a graph showing an example of near infrared spectra of the raw milk wherein an ordinate gives absorbances represented by figures obtained by logarithmically converting reciprocals of light reflectances, and an abscissa denotes

wavelengths (nm). A curve corresponds to an absorption spectra obtained by scanning over a wavelength of 1100 nm to 2500 nm with use of the spectroscopy 9. In FIG. 5, results obtained by measuring plural raw milk samples are displayed, while overlapped.

[0042] All the curves are attributable to absorption spectra of water, and large peaks particularly near 1400 nm to 1500 nm and near 1850 nm to 2050 nm are attributable to molecular vibrations of water.

[0043] The above explanation is made on the transmission and reflection type construction where the light rays to be measured pass the sample SP, reflected at the inner surface of the sample container 41 and pass the sample SP again. In addition, measurement may be also made by a transmission type where the sample container 41 is made of a transparent material, and a transmitted lights having passed the sample SP are detected or a reflection type where the light rays reflected from the surface of the sample SP are measured.

[0044] The above explanation is made on the construction example where the spectroscopy 9 is arranged between the light source 1 and the sample SP and the light rays to enter the sample SP are separated. In addition, a construction example may be used, where the spectroscopy 9 is arranged between the sample SP and the light detector 20, and the transmitted light rays from the sample SP or the transmitted and reflected light rays are split.

[0045] Next, the SIMCA method (Soft Independent Modeling of Class Analogy) which is one of the multivariate analyses using classified models based on probability, separability or similarity. FIG. 6 schematically shows a method for diagnosing the mastitis with use of a raw milk according to the SIMCA method. A group of each of known healthy cows and mastitic cows are subjected to the principal component analysis (grouping), thereby preparing principal component models for each of the groups. An unknown sample is compared with these groups, and is allotted to either one of the principal component models (healthy cow group or mastitic cow group) which the unknown sample generally fits. The overall concept of the SIMCA method is shown in FIG. 7. An optimum SIMCA model is prepared from absorbance detection data of $\frac{2}{3}$ of known samples and those detection data of $\frac{1}{3}$ of the known samples, the presence of the mastitis is diagnosed by spectral data of an unknown sample by subjecting the spectra data to the multivariate analysis. The SIMCA method is known, and details of it will be omitted. See Tetsuro Aijima, "Chemometrics-New Analytic Chemistry", published by Maruzen in 1992, Mutsuo Iwamoto, Sumio Kono and Jun Uozumi., "Introduction to Near Infrared Spectroscopy", published by Saiwai Shobou in 1994, and Sachihiko Ozaki and Akira Koda, "Near Infrared Analytical Method" published by Gakkai Publication Center in 1996.

[0046] Table 1 gives a graph showing mastitis-discriminated results obtained by the SIMCA method as one of the multivariate analysis methods using the classification model based on the probability, separability or similarity.

[0047] The SIMCA method makes judgments in two ways whether given raw milk is that from a mastitic cow or that of a healthy cow. The hitting ratio for the mastitis was 99.25% at the time of the preparation of the model, and that was 95.44% when the unknown data were used. That is, 134

raw milk samples (data for the model preparation and data for the model inspection) were prepared, a SIMCA model consisting of Class 1 for spectra data of raw milk samples in which the number of somatic cells was less than 300,000/ml and Class 2 for spectra data of raw milk samples in which the number of somatic cells was not less than 300,000/ml was prepared. At that time, 133 raw milk samples were classified into the correct classes, and one raw milk sample did not fit the SIMCA model. Further, unknown 66 raw milk samples were diagnosed according to the SIMCA model, which revealed that 63 raw milk samples were correctly diagnosed, and 3 raw milk samples were incorrectly diagnosed. Whether the diagnosis was correct or not was confirmed by a qualitative analysis or an expert diagnosis.

TABLE 1

	Diagnosis on preparation of SIMCA model		Diagnosis of Unknown raw	
	Erroneously diagnosed	Erroneously diagnosed	Erroneously diagnosed	Erroneously diagnosed
Number of milk (n)	133	1	63	3
Percentage (%)	99.25	0.75	95.45	4.55

[0048] Next, cow urine samples were subjected to the principal component analysis (grouping) in the same way as mentioned above with respect to respective groups of known healthy cows and mastitic cows, thereby preparing principal component models for the respective groups. An unknown urine sample is compared with these groups, and is allotted to either one of the principal component models (healthy cow group or mastitic cow group). An optimum SIMCA model is prepared, and whether the cow from which the urine is sampled is suffering the mastitis or not is diagnosed by subjecting the spectra data to the multivariate analysis.

[0049] Table 2 shows mastitis-discriminated results based on urine spectra obtained by the SIMCA method as one of the multivariate analysis methods using the classified models based on the probability, separability or similarity.

[0050] The SIMCA method makes judgments in two ways whether given urine is that from a mastitic cow or that of a healthy cow. The hitting ratio for the mastitis was 96% at the time of the preparation of the model, and that was 85% when the unknown data were used. That is, 79 urine samples (data for the model preparation and data for the model inspection) were prepared, a SIMCA model consisting of Class 1 for spectra data of urine samples for which the number of somatic cells was less than 300,000/ml and Class 2 for spectra data of urine samples for which the number of somatic cells was not less than 300,000/ml was prepared. At that time, 76 urine samples were classified into a correct classes, and 3 urine sample did not fit the SIMCA model. Further, unknown 39 urine samples were diagnosed according to the SIMCA model, which revealed that 33 urine samples were correctly diagnosed, and 3 urine samples were incorrectly diagnosed. Whether the diagnosis was correct or not was confirmed by a qualitative analysis or an expert diagnosis.

TABLE 2

	Diagnosis on preparation of SIMCA model		Diagnosis of Unknown raw	
	Erroneously diagnosed	Erroneously diagnosed	Erroneously diagnosed	Erroneously diagnosed
Number of milk (n)	76	3	33	6
Percentage (%)	96	2	85	15

[0051] As mentioned above, according to the present invention, the mastitis can be diagnosed by detecting the intensity of transmitted light rays, reflected light rays or transmitted and reflected light rays from urine, urine or mammary gland, effecting the multivariate analysis of the obtained absorbance data by using a classification model based on probability, separability or similarity.

[0052] The mastitis can be readily diagnosed at a high precision by the optical measurement of urine and data processing.

What is claimed is:

1. A method for diagnosing mastitis of cows, comprising the steps of irradiating visual light rays and/or near infrared rays in a wavelength range of 400 to 2500 nm into urine, raw milk or a mammary gland of a cow, detecting an intensity of transmitted light rays, reflected light rays or transmitted and reflected light rays from said urine, raw milk or mammary gland, effecting multivariate analysis by using a classification model based on probability, separability or similarity, and diagnosing the presence of the mastitis of the cow.

2. A method for diagnosing mastitis of cows set forth in claim 1, comprising the steps of irradiating near infrared rays in a wavelength range of 700 nm to 2500 nm into urine, raw milk or a mammary gland of a cow, detecting an intensity of transmitted light rays, reflected light rays or transmitted and reflected light rays from said urine, raw milk or mammary gland, effecting multivariate analysis by using a classification model based on probability, separability or similarity, and diagnosing the presence of the mastitis of the cow.

3. A method for diagnosing mastitis of cows, comprising the steps of irradiating near infrared rays in a wavelength range of 700 nm to 1100 nm or 1100 nm to 2500 nm into urine, raw milk or a mammary gland of a cow, detecting an intensity of transmitted light rays, reflected light rays or transmitted and reflected light rays from said urine, raw milk or mammary gland, effecting multivariate analysis by using a classification model based on probability, separability or similarity, and diagnosing the presence of the mastitis of the cow.

4. The cow mastitis-diagnosing method set forth in any of claims 1 to 3, which comprising scanning wavelengths of incident rays, transmitted light rays, reflected light rays or transmitted and reflected light rays from said urine, raw milk or mammary gland, and applying the multivariate analysis to

the thus obtained spectra of the visual light rays and/or the near infrared rays by using the classification model based on the probability, separability or similarity.

5. The cow mastitis-diagnosing method set forth in any of claims 1 to 4, wherein the multivariate analysis is effected of the visual light rays and/or the near infrared rays by using the classification model based on the probability, separability or similarity according to a SIMCA method.

6. An apparatus for diagnosing mastitis of cows, comprising:

a near infrared ray generator for generating visual light rays and/or near infrared rays in a wavelength range of 400 to 2500 nm;

an optical system for introducing the visual light rays and/or near infrared rays into urine, raw milk or a mammary gland of a cow;

a detector for detecting an intensity of transmitted light rays, reflected light rays or transmitted and reflected light rays from said urine, raw milk or mammary gland;

and a data processor for receiving signals from said detector, and effecting multivariate analysis by using a classification model based on probability, separability or similarity to diagnose the presence of the mastitis of the cow.

7. The cow mastitis-diagnosing apparatus set forth in claim 6, wherein said near infrared ray generator is an infrared ray generator for generating a near infrared rays in a wavelength range of 700 to 2500 nm, an infrared ray generator for generating a near infrared rays in a wavelength range of 700 to 1100 nm, or an infrared ray generator for generating a near infrared rays in a wavelength range of 1100 to 2500 nm.

8. The cow mastitis-diagnosing apparatus set forth in claim 6 or 7, which further comprises an optical fiber from said near infrared ray generator for introducing the visual light rays and/or near infrared rays into said urine, raw milk or a mammary gland of the cow, and transmitted light rays, reflected light rays or transmitted and reflected light rays from said urine, raw milk or mammary gland is led to said detector through the optical fiber.

9. The cow mastitis-diagnosing apparatus set forth in any of claims 6 to 8, which further comprises a feeder for introducing said raw milk into a sample container via an on-line or at line.

10. The cow mastitis-diagnosing apparatus set forth in any of claims 6 to 9, which further comprises a sample container for holding the raw milk, and a temperature controller for stabilizing the milk inside the sample container to a given temperature.

11. The cow mastitis-diagnosing apparatus set forth in any of claims 6 to 10, wherein the multivariate analysis is effected of the visual light rays and/or the near infrared rays by using the classification model based on the probability, separability or similarity according to a SIMCA method.

* * * * *

专利名称(译)	通过使用可见光线和/或近红外光检测乳腺炎的方法和设备		
公开(公告)号	US20020198441A1	公开(公告)日	2002-12-26
申请号	US09/980223	申请日	2001-03-14
[标]申请(专利权)人(译)	TSENKOVA ROUMIANA		
申请(专利权)人(译)	TSENKOVA ROUMIANA		
当前申请(专利权)人(译)	TSENKOVA, ROUMIANA 本地公司		
[标]发明人	TSENKOVA ROUMIANA		
发明人	TSENKOVA, ROUMIANA		
IPC分类号	G01N21/27 G01N21/35 G01N21/359 G01N33/04 G01N33/48 A61B5/00		
CPC分类号	G01N33/04 G01N21/359		
优先权	2000099144 2000-03-31 JP		
其他公开文献	US6793624		
外部链接	Espacenet USPTO		

摘要(译)

一种诊断奶牛乳房炎的方法，包括以下步骤：(1) 将400至2500nm波长范围内的可见光线和/或近红外线照射到尿液，生乳或奶牛的乳腺中，(2) 检测透射光线，反射光线或来自所述尿液，原料乳或乳腺的透射和反射光线的强度，以及(3) 在使用基于概率，可分离性或相似性的分类模型时进行多变量分析，并且(4) 诊断奶牛乳房炎的存在。

