



(19) **United States**

(12) **Patent Application Publication**

(10) **Pub. No.: US 2002/0013527 A1**

Hoek et al.

(43) **Pub. Date:**

Jan. 31, 2002

(54) **METHOD AND SENSOR FOR WIRELESS MEASUREMENT OF PHYSIOLOGICAL VARIABLES**

Related U.S. Application Data

(62) Division of application No. 09/219,798, filed on Dec. 23, 1998, now Pat. No. 6,312,380.

(76) Inventors: **Bertil Hoek**, Vaesteras (SE); **Lars Tenerz**, Uppsala (SE); **Ola Hammarstroem**, Lerdala (SE); **Per Benkowski**, Uppsala (SE); **Paer von Malmborg**, Uppsala (SE)

Publication Classification

(51) **Int. Cl.⁷** **A61B 8/00**
(52) **U.S. Cl.** **600/437**

Correspondence Address:
Glenn Law
FOLEY & LARDNER
Washington Harbour
3000 K Street, N.W., Suite 500
Washington, DC 20007-5109 (US)

(57) **ABSTRACT**

The sensor and guide wire assembly having a sensor element is inserted into the patient's body. Acoustic or electromagnetic waves are then emitted from an external source toward the sensor element. The sensor element receives the incident waves and enters into a resonating state. The characteristics of the resonance correspond to the variable or variables to be measured. A transducer is located externally from the patient's body and receives the scattered wave and transmits a resultant signal to an electronic drive end detection unit for signal analysis.

(21) Appl. No.: **09/949,951**

(22) Filed: **Sep. 12, 2001**

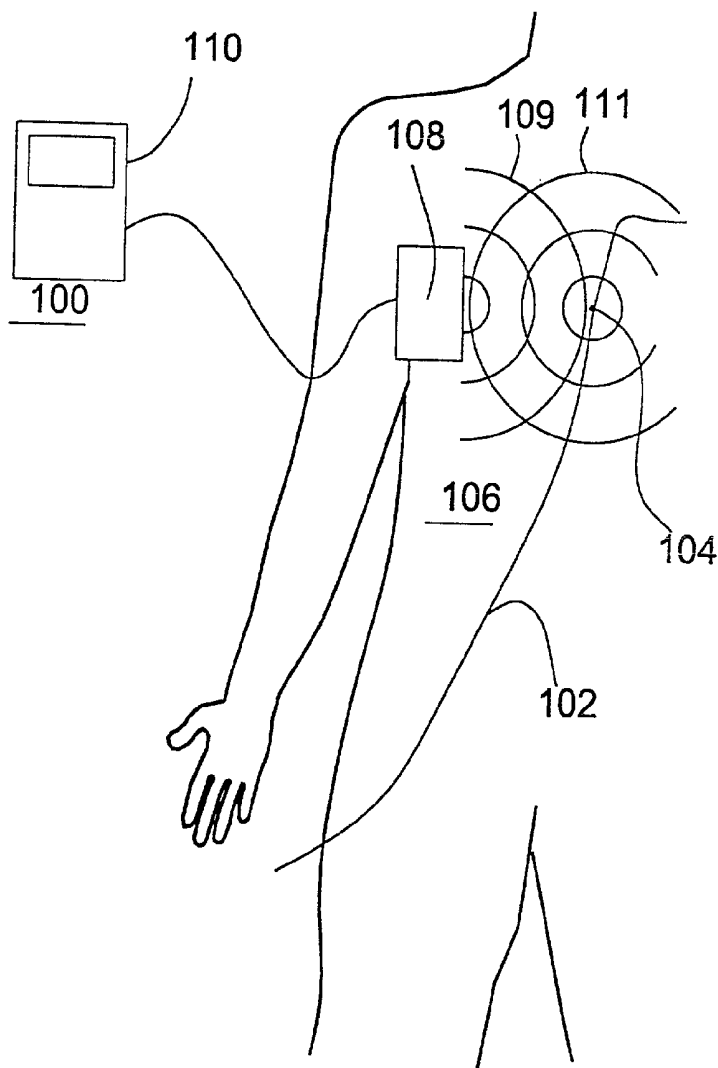

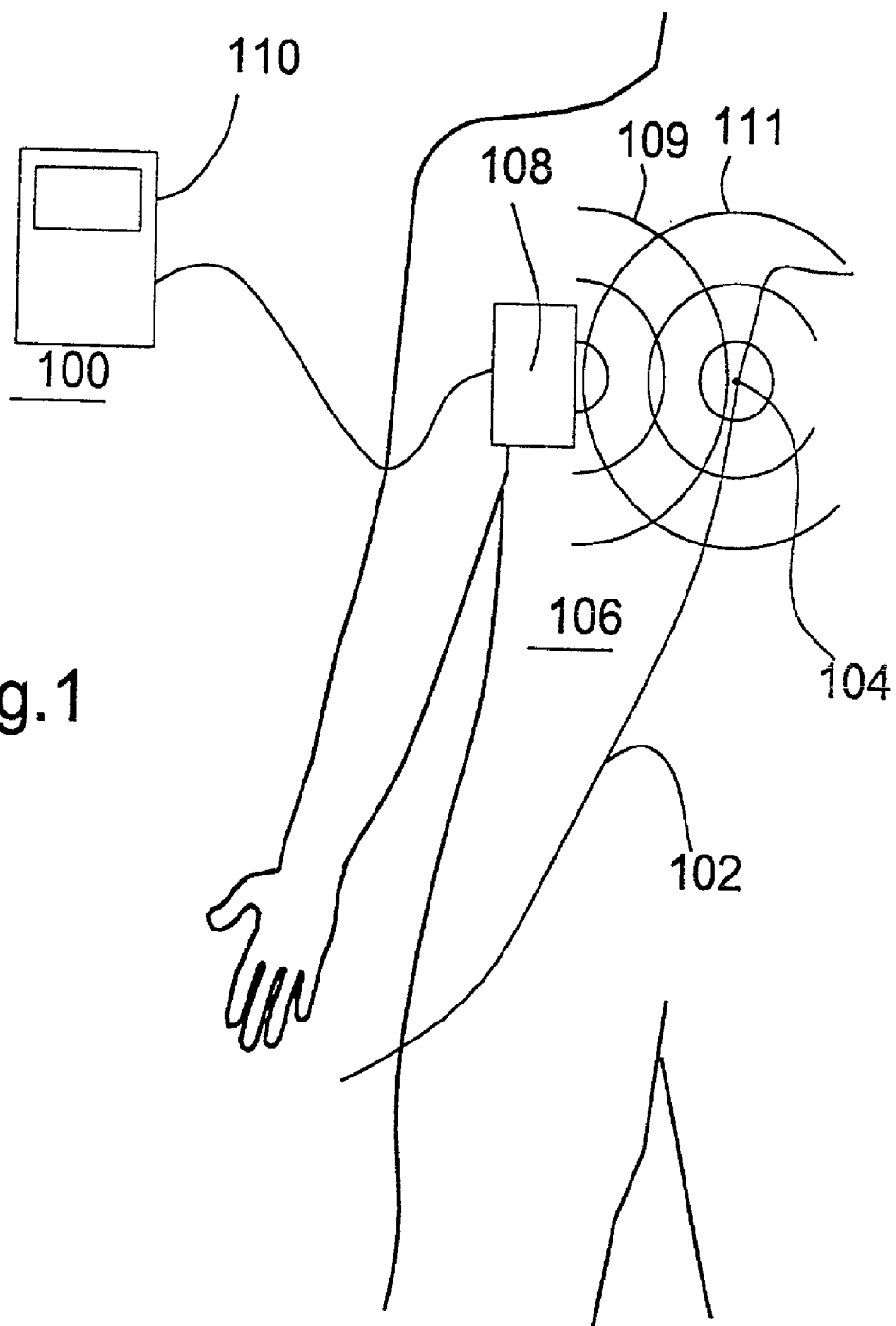

Fig.1

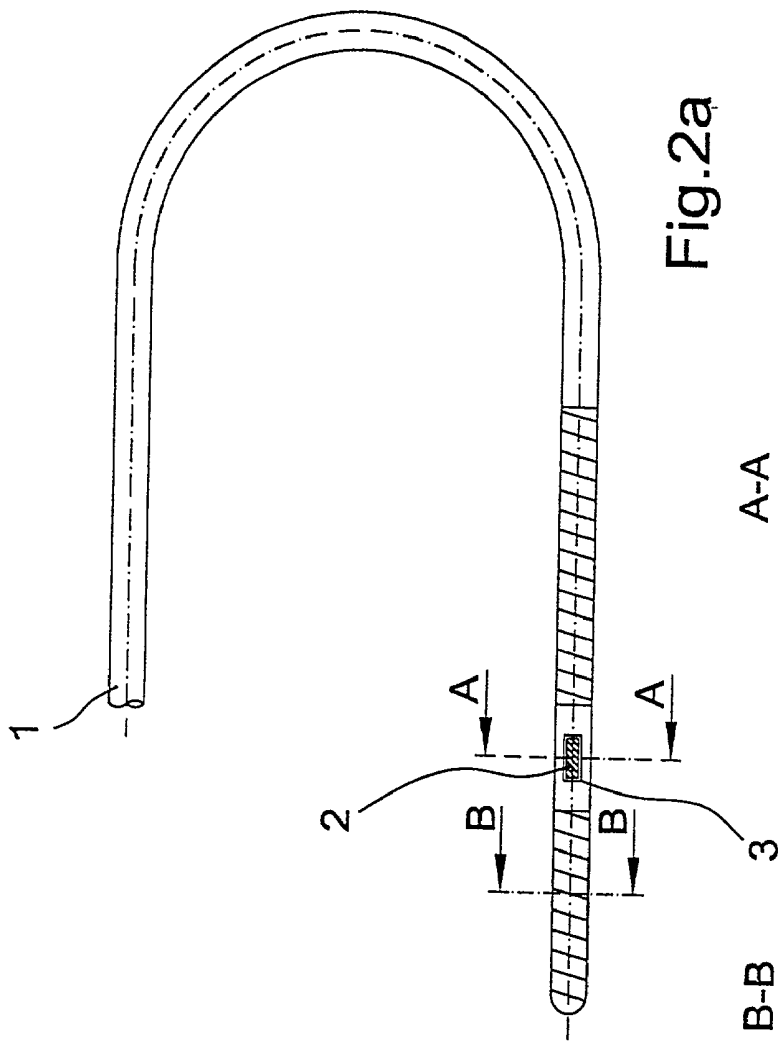

Fig. 2a

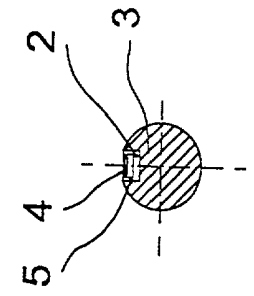

Fig. 2b

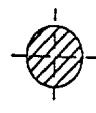
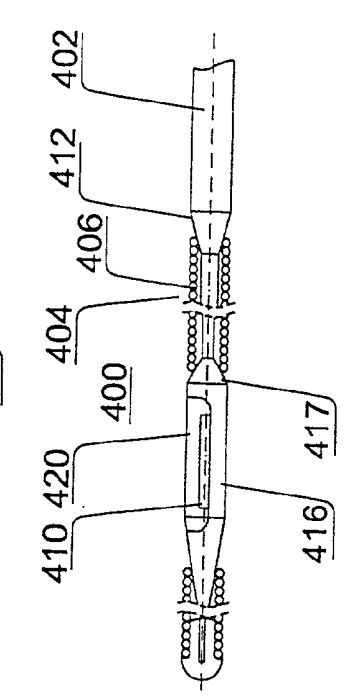
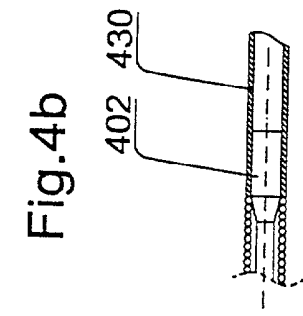
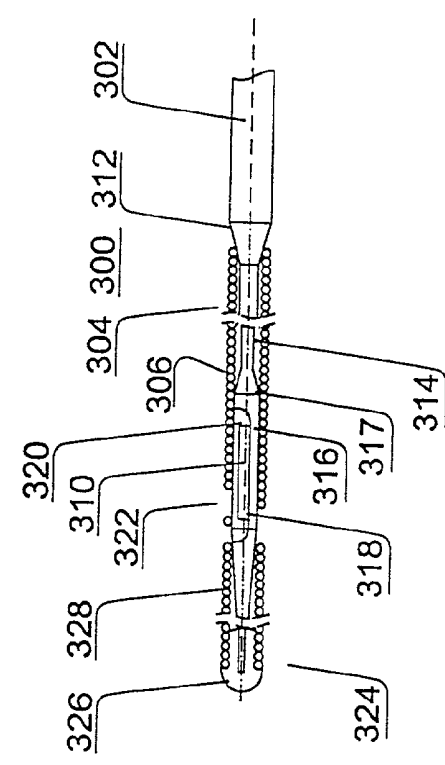
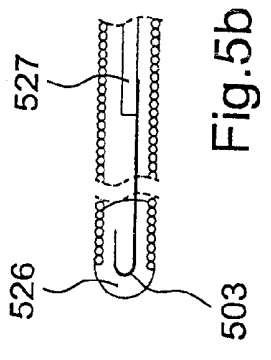
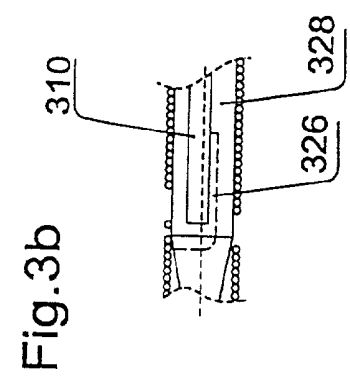

Fig. 2c



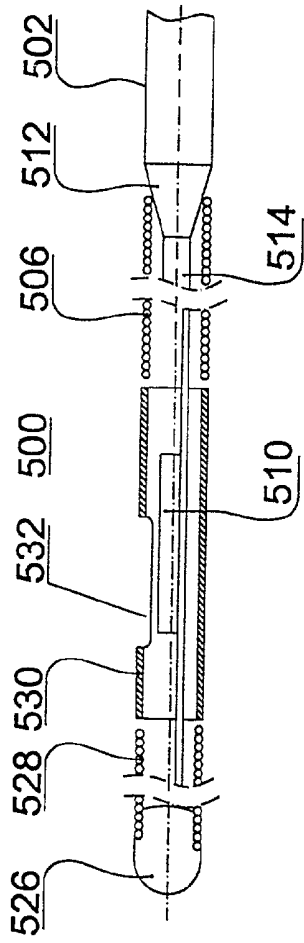

Fig. 5a

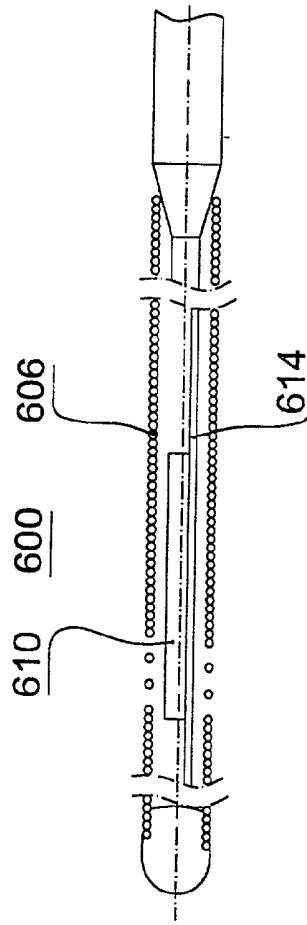

Fig. 6

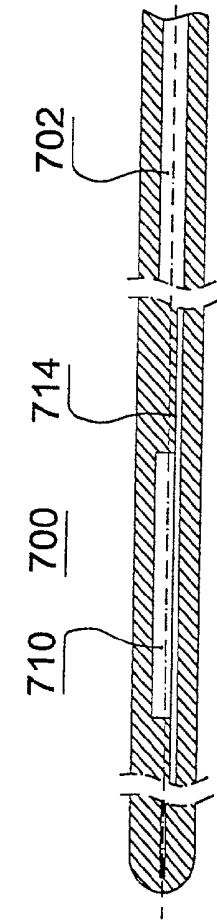

Fig. 7

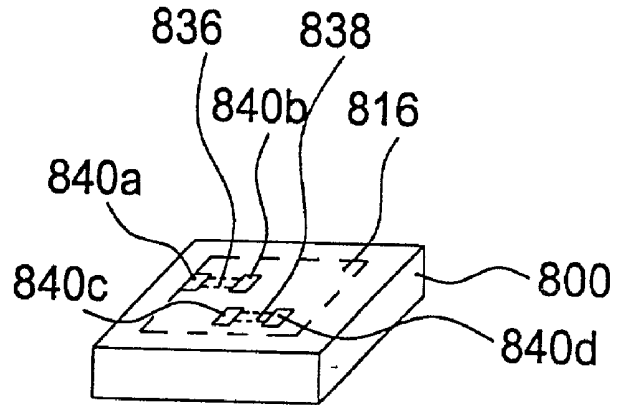

Fig. 8a

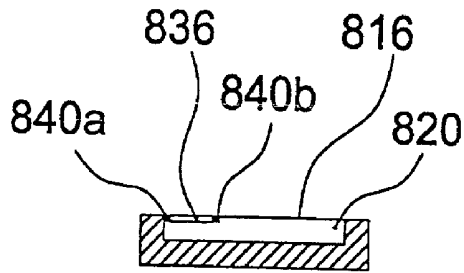

Fig. 8b

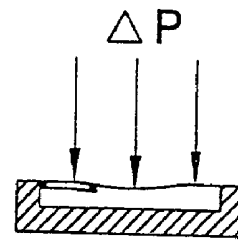

Fig. 8c

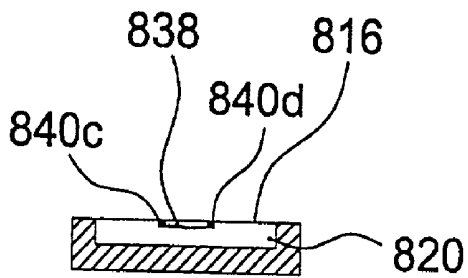

Fig. 8d

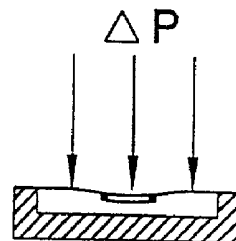

Fig. 8e

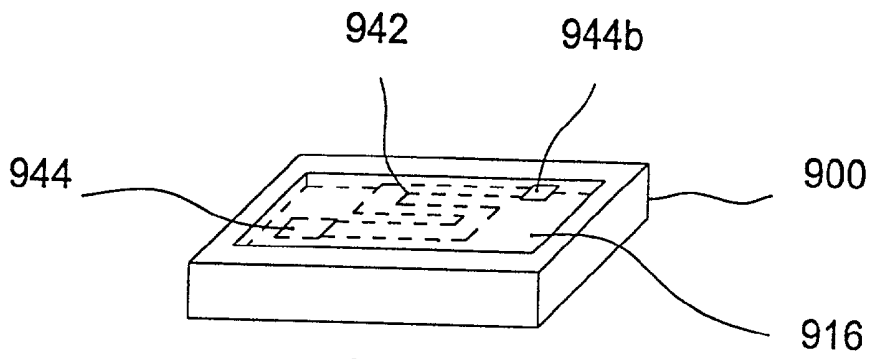

Fig. 9

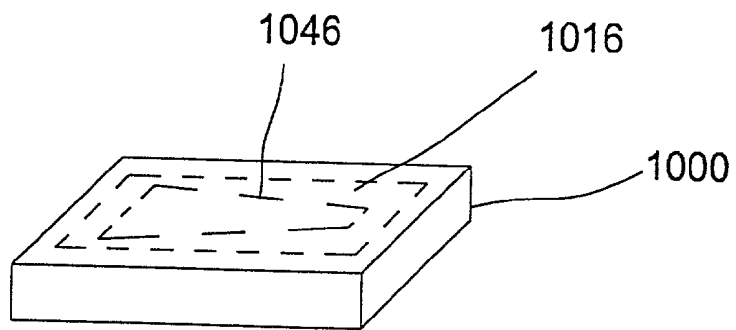

Fig. 10a

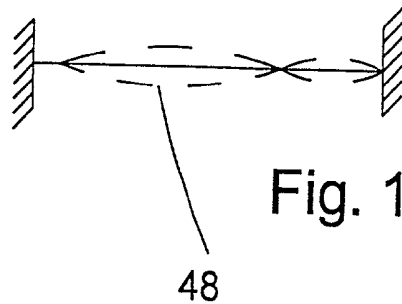

Fig. 10

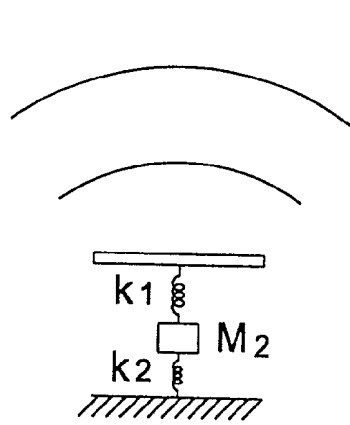

Fig. 11a

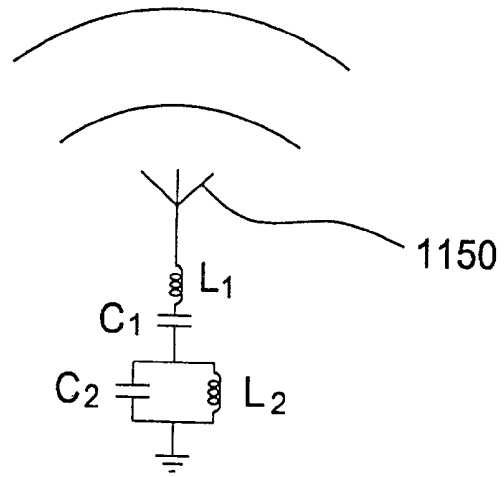

Fig. 11b

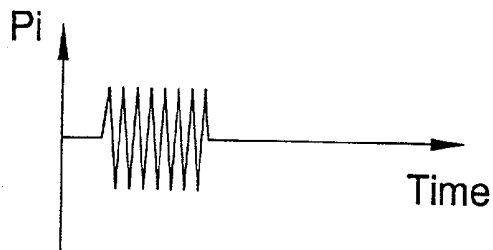

Fig. 12a

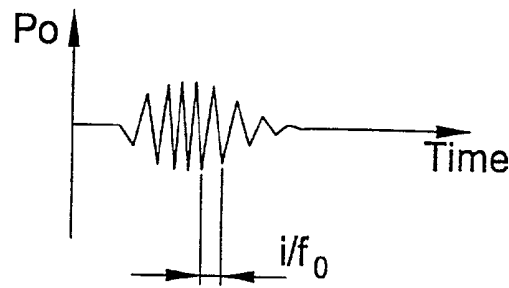

Fig. 12b

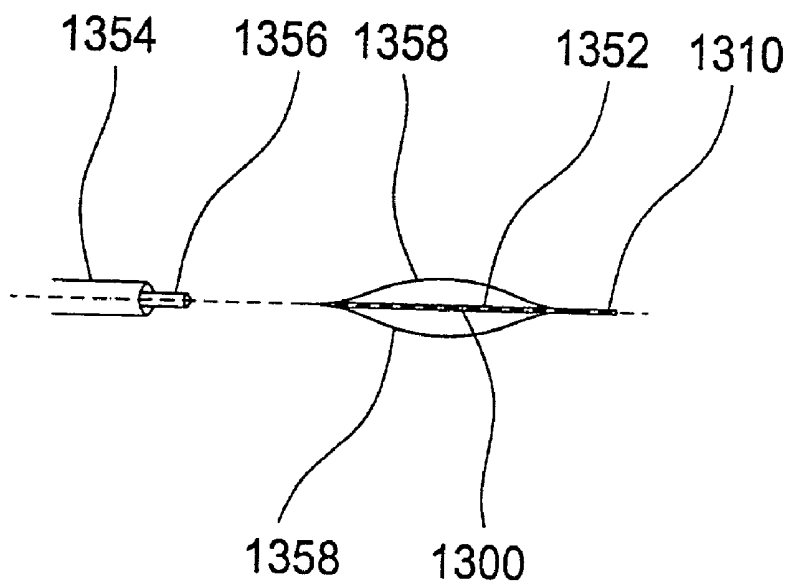

Fig. 13

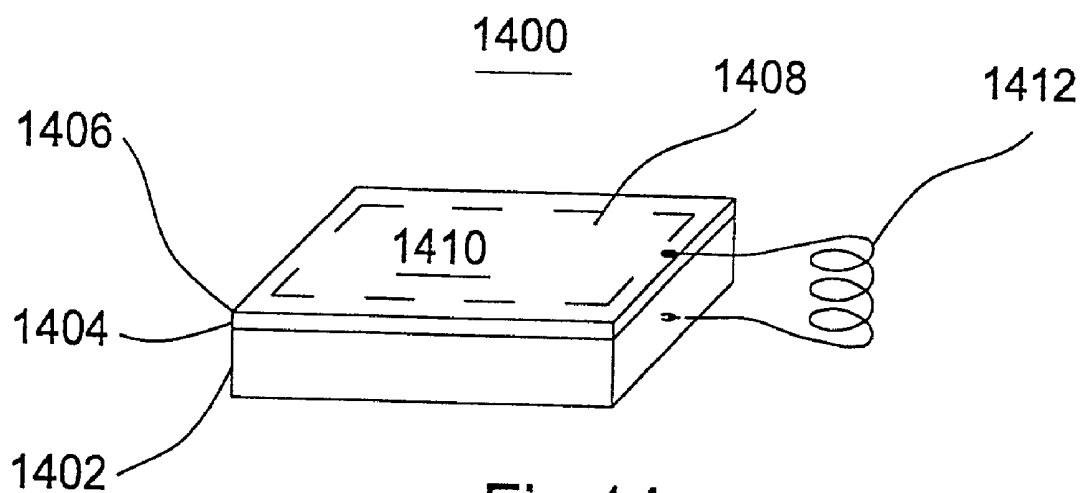

Fig. 14

METHOD AND SENSOR FOR WIRELESS MEASUREMENT OF PHYSIOLOGICAL VARIABLES

BACKGROUND OF THE INVENTION

[0001] 1. Field of the Invention

[0002] The invention relates to a novel method, system, sensor and sensor/guide wire assembly for measuring physiological variables inside the body of a human or an animal. More particularly, it relates to a wireless sensor having a diaphragm comprising elements responsive to resonance.

[0003] 2. Description of Related Art

[0004] Intravascular measurements of pressure, flow, and temperature via sensors mounted to guidewires, as disclosed in U.S. Pat. No. 5,226,423, Tenerz, reissued as Re. 35,648, are of particular interest to the health care industry, and serve as tangible examples of embodiments of system solutions, device designs, components and materials to be used in the realization of the invention.

[0005] Implantable devices for physiological measurements and therapy have been used for decades, for example, in combination with cardiac pacemakers. These device carry their own power supply, are relatively bulky, and require a surgical procedure to be implanted into the patient's body.

[0006] For short term diagnostic procedures, such as intravascular measurements of pressure, flow, and temperatures the current state of the art utilizes micromechanical sensor elements, mostly silicon devices based on well known piezoresistive, capacitive, or fiber optic principles. The devices communicate information and power along a guidewire via thin optical fibers or insulated electrical leads. The guidewire is extremely small, preferably with an overall diameter no larger than 0.4 mm. Housing multiple wires in a guide wire with such an extremely small area is very difficult from a technological standpoint and is also very costly. Other difficulties arise, including, maintaining the structural integrity and the mechanical properties of the guidewire while encompassing within the guide wire the power and information transmission media. Moreover, weak points, in terms of sensor performance (e.g., zero point stability) and mechanical reliability, exist at the connecting points between the sensor and the information and power transmission wires.

[0007] A wireless system for recording pressure in the eye is disclosed in the following articles "Passive Silicon Transensor Intended for Biomedical, Remote pressure Monitoring" by Bäcklund, Y. et al in *Sensors and Actuators*, A21-A23 (1990) 58-61, Elsevier Sequoia; "A System for Wireless Intra-ocular Pressure Measurements Using Silicon Micromachined sensor" by Rosengren, L. et al in *J. Of Micromech. Microeng.* 2(1992) 202-204, IOP Publishing Ltd; and "A system for Passive Pressure Implantable Pressure Sensors" by Rosengren, L. et al in *Sensors and Actuators A*, 1994, Elsevier Sequoia. The disclosures of these publications are hereby incorporated in this specification by reference.

[0008] The wireless system disclosed in these articles comprises an electromagnetic sensor device of an L-C circuit type: having the capability of resonating in response to an excitation by an externally applied electromagnetic

field, and to change its resonance frequency in response to a pressure change. The sensor is implanted/inserted into the eye, and excitation energy is applied. The shift in resonance frequency due to change in pressure exerted on the device is registered.

[0009] The difficulties suggested in the preceding are not intended to be exhaustive but rather are among many which tend to reduce the desirability of the known devices. Other noteworthy problems may exist; however, those presented above should be sufficient to demonstrate that such methods and apparatuses appearing in the past will admit to worthwhile improvement.

SUMMARY OF THE INVENTION

[0010] Accordingly, it is therefore a general object of the invention to provide a method and apparatus that will obviate or minimize difficulties of the type previously described.

[0011] It is a specific object of the invention to provide a method and device for measuring physiological variables able to transmit information without the use of wires.

[0012] It is another object of the invention to provide a device with high mechanical reliability for measuring physiological variables.

[0013] It is still another object to provide a relatively small device for measuring physiological variables.

[0014] It is a further object to provide a device for measuring physiological variables that has virtually no weak points.

[0015] It is yet a further object of the invention to provide a device that can be produced in a cost effective manner.

[0016] It is still a farther object of the invention to provide a method for measuring physiological variables inside a human or an animal body.

[0017] For the purpose of this application, a "resonance sensor" is meant to encompass any device that has the capability of resonating at a defined frequency upon excitation by energy/power from an external source, i.e. without physical contact between source and device, and in addition to have the capability of changing its resonance frequency in a defined way as a result of a change of a physical variable, such as pressure, temperature or fluid flow, that the device is being exposed to. Alternatively, the quality factor of the resonating device may be affected by said change, and can be used for detection purposes.

[0018] A preferred embodiment of the invention that is intended to accomplish at least some of the foregoing objects includes a guidewire and a sensor element attached to said guidewire, wherein said sensor element has no wires for transmitting or receiving information. A preferred method includes inserting a guidance into a patient's body; transmitting waves to a sensor mounted on the guidewire; redistributing the waves, the redistributing being a function of the physiological variable; and receiving the redistributed waves.

[0019] Additional objects and advantages of the invention will be set forth in the description that follows, and in part will be obvious from the description, or may be learned by practice of the invention. The objects and advantages of the

invention may be realized and obtained by means of the instruments and combinations particularly pointed out in the appended claims.

BRIEF DESCRIPTION OF THE DRAWINGS

[0020] The accompanying drawings, which are incorporated in and constitute a part of the specification, illustrate a number of presently preferred embodiments of the invention, and, together with the general description of the preferred embodiment below, serve to explain the principles of the invention.

[0021] FIG. 1 is a schematic overview of a system according to the present invention;

[0022] FIG. 2a is a schematic view of a sensor and guide wire assembly in general;

[0023] FIG. 2b is a crosssection at A-A FIG. 2a;

[0024] FIG. 2c is a crosssection at B-B in FIG. 2a

[0025] FIG. 3a is a longitudinal view of an embodiment of a sensor and guide wire assembly according to the invention;

[0026] FIG. 3b is a detail view of a sensor mounting site;

[0027] FIG. 4a is a longitudinal view of another embodiment of a sensor and guide wire assembly according to the invention;

[0028] FIG. 4b is a detail view of a part of a sensor and guide wire assembly according to the invention;

[0029] FIG. 5a is a longitudinal view of still another embodiment of a sensor and guide wire assembly according to the invention;

[0030] FIG. 5b is a cross section of the very distal part of a sensor and guide wire assembly according to the invention;

[0031] FIG. 6 is a longitudinal view of still another embodiment of a sensor and guide wire assembly according to the invention;

[0032] FIG. 7 is a longitudinal view of a still further embodiment of a sensor and guide wire assembly according to the invention;

[0033] FIGS. 8a-8e illustrate a first embodiment of the sensor element according to the invention;

[0034] FIG. 9 illustrates an alternative embodiment of a sensor element according to the invention;

[0035] FIG. 10a illustrates another embodiment of a sensor element according to the invention;

[0036] FIG. 10b shows a vibration mode of the embodiment of FIG. 10a;

[0037] FIG. 11a is a schematic of the mechanical elements of an acoustically coupled resonating structure, and FIG. 11b is a schematic of an electromagnetically coupled resonating structure;

[0038] FIGS. 12a-12b depict a graphical representation of incident and redistributed or modulated power according to one embodiment of the invention;

[0039] FIG. 13 is a side view of an embodiment of the sensor according to the invention adapted for permanent or temporary implantation within a human or animal body; and

[0040] FIG. 14 shows an embodiment of the sensor element based on electromagnetic resonance.

DETAILED DESCRIPTION OF THE PREFERRED EMBODIMENTS

[0041] In FIG. 1 a system according to the present invention, generally designated 100 is schematically illustrated.

[0042] It comprises a guide wire 102 provided with a resonance sensor 104 at its distal end portion. The resonance sensor may be of several types, and this will be discussed in further detail below. The guide wire and sensor is schematically shown to be inserted or implanted in the body of a patient 106. There is provided a transducer 108 for emitting excitation energy, said transducer being preferably located in the vicinity of the body, near the location where the sensor 104 is located, or even in contact with the body, and directed towards the sensor element 104, in such a manner that an emitted power (e.g. electromagnetic or ultrasonic) wave 109 hits the sensor element 104. The ultrasonic power incident on the sensor element is redistributed or modulated by the sensor element in such a way that the characteristics of modulation corresponds to the variable or variables to be measured. The scattered ultrasonic wave 111 thus carries information about the measurand, and conveys this information back to the transducer 108, which, when operating in the receiver mode brings a signal back to an electronic drive/control and detection unit 110, e.g. a PC, for signal analysis. Typically, the transducer 108 operates at a frequency of 0.1-10 MHz.

[0043] The transducer can be of various types depending on the type of sensor 104 being employed. Thus, if the sensor is of the electromagnetic type, i.e. being excitable by electromagnetic energy, the transducer may be of a type such disclosed in the articles mentioned in the discussion of the background of the invention.

[0044] Alternatively the sensor may be a mechanically resonating type sensor, in which case the transducer may be an ultrasonic transducer. An example of such a transducer is a piezoresistive plate made from a ceramic material, such as lead titanate-zirconate. By applying voltage pulses to such a material, mechanical deformations will appear, which in turn will give rise to the emission of ultrasonic power. Conversely, such an element will also function as a receiver of ultrasonic waves. The transducers are state of the art and do not per se belong to the invention.

[0045] In a preferred embodiment the sensor is mounted on a guide wire. This means of inserting a sensor into a body is per se well-known and does not form part of the invention. However, the provision of a resonance sensor of the type contemplated by the invention is novel and inventive, and bus about the possibility of wire less detection of physical variables, preferably physiological variables.

[0046] The present invention makes use of the transmission properties of human or animal tissue, to communicate power and information. In fact, power and information can be efficiently transmitted through human soft or hard tissue in a number of ways, including acoustic and electromagnetic waves. The invention makes efficient use of this property in

redistributing or modulating the incident power of an acoustic or electromagnetic wave in such a way that information gathered by a sensor element can be accessible by external means. More specifically, the redistribution or modulation of power is performed by one or several resonating elements, exhibiting a degree of coupling towards the incident wave. The property of these resonators is to carry and transmit information linked to the physiological variables to be measured, i.e., pressure, flow or temperature, at the sensor location. By redistributing, or modulating the incident power, information about the variables to be measured is thus transferred to the surrounding medium and is thus externally accessible. In a preferred embodiment, the guidewire includes one wire without joints along its length. This is a preferred solution from a reliability point of view. Moreover, the guidewire includes sections of different bending flexibility, notably with maximum flexibility in the vicinity of the distal end, to prevent issue perforation.

[0047] The present invention has significant advantages compared to the previous known devices. First, it eliminates the need for a mechanical connection between the sensor and external equipment. Second, its use in permanently implanted devices also minimizes the risk of contamination and infection. Third, it has a simplified construction and improved mechanical properties. Four, it reduces the cost of manufacture of the sensor guide assembly. Five, it has the potential of improving overall system reliability by eliminating weak points.

[0048] Referring now to FIG. 2a, there will be seen a guidewire 202 having a distal end 224 and a proximal end 225. The guidewire preferably has a length of between 60 and 350 centimeters and an outer diameter of between 0.3 and 1.5 millimeters in order to be accommodated with the usual catheters. The guidewire 202, preferably, is constructed of a wire of a non-corrosive and bio-compatible material, such as stainless steel, titanium, memory metal such as NITINOL®, platinum, tungsten or the like.

[0049] The guidewire 202 also preferably has a maximum bending flexibility at or near its distal end 224, 226. To create the maximum bending flexibility at the distal end 224, 226 of the guidewire 202, the distal end 224, 226, preferably, is constructed such that it has a smaller cross-sectional area than the proximal end 225, as seen in FIGS. 2b and 2c, sections A-A and B-B respectively. The appropriate bending and torsional flexibility is essential to ensure proper mechanical operation of the guidewire 202 while inserting it through the body, for example, through bifurcated blood vessels. Preferably, the section having the highest bending flexibility extends, approximately, 20 to 30 millimeters from the tip of the guidewire 202. The guidewire 202 then gradually increases in thickness as shown in FIG. 1a.

[0050] As shown in FIG. 2a, a coil 206 can be wrapped around the distal end 224, 226 of the guidewire 202 to increase the guidewire's strength without substantially decreasing, the bending flexibility of the guidewire 202.

[0051] The guidewire 202 has a slot 220 located about 30 to 50 millimeters from the tip of the guidewire. The slot 220, preferably, has a length of about 1 to 2 millimeters and a width of approximately 50 to 250 micrometers. The slot 220 contains the sensor element 210. The sensor element 210 is fixedly mounted in the slot 220, as seen in section B-B, for example, via an adhesive or without an adhesive.

[0052] In FIG. 3a a first preferred embodiment of the sensor and guide wire assembly 300 according to the invention is shown. It comprises a wire 302 of a non-corrosive and biocompatible material such as stainless steel, titanium, NITINOL®, platinum or tungsten, having a maximum bending flexibility in the vicinity of the distal end 304. As can be seen in the figure the wire 302 is of uniform thickness over the major part of its length from the proximal end towards the distal end, but about 30-35 cm from the distal it has been reduced in diameter in order to increase its flexibility. Preferably the diameter reduction is obtained by providing the major part of the reduction over a rather short distance, say 1-5 cm indicated at 312 in the figure, and then gradually further reducing the diameter along the next 30 cm or so, indicated at 314.

[0053] This section of the guide wire having the reduced diameter is enclosed in a coil 306, which is used in a preferred embodiment to maintain the same outer diameter over the entire length of the guide wire, while still retaining high bending flexibility. Also this coil will act as a kind of "roller bearing" inside a vessel, by virtue of the fact that the coil may rest against the inner walls of a vessel, while the core wire is rotatable. The coil 306 is attached by soldering or gluing, or possibly by threading it onto the wire. Alternatively it is contemplated to use a sleeve or tube of a polymer material enclosing a core wire made of memory metal.

[0054] After the 30 cm long section with reduced diameter and thereby increased flexibility, there is provided a thicker portion 316. The thickness is not abruptly increased but instead a tapered portion 317 is provided. This thicker portion forms the mounting site 318 for a resonance sensor 310. In this embodiment the mounting portion 316 has a diameter slightly smaller than that of the wire 302 at the proximal part, in order that the coil 306 may enclose the mounting portion 316 partially over its length. The mounting portion 316 is provided with a slot 320 in which the sensor 302 is located and attached by suitable means such as gluing, bonding or soldering, or by any other appropriate means that meets the requirements to achieve the objects of the invention. The slot is preferably made by spark machining. The coil 306 will, as indicated above, cover only a part of the mounting portion 316, leaving an opening 322 through which the surrounding medium, e.g. blood or other body fluids, will access the sensor 302, which thereby will respond to changes in the environment.

[0055] The distal end 324 of the mounting portion 316 will again have a reduced diameter, such that very tip of the wire is about only 10-20% of the nominal diameter of the wire. The very tip is anchored in an end plug 326. The part extending from the point where the diameter of the mounting portion 316 begins to be reduced is enclosed in a coil 328, similar to the coil 326.

[0056] In FIG. 3b there is shown an alternative embodiment of the mounting site for the sensor 310. Here the slot 320 is recessed 326 further so as to form a "shelf" 328 on which the sensor 310 is mounted, whereby the sensor cantilevers out from said shelf 328 over the recessed part 326. This alternative is equally applicable to the embodiment of the sensor and guide wire assembly shown in FIG. 4, to be described below.

[0057] In FIG. 4a there is disclosed an alternative embodiment, which in the main is the same as the embodi-

ment of FIG. 3a. Thus there is provided a wire 402 having increased bending flexibility near the distal end 404, achieved by a diameter reduction at 412 and then gradually over a distance. There is also provided a sensor mounting portion 416 having a recess 420 in which a sensor 410 is positioned. At the distal extension this embodiment is virtually identical to the embodiment of FIG. 3a.

[0058] However, there is one important difference, in that the mounting portion 416 is made thicker than in the embodiment of FIG. 3a. Thus, the diameter of the mounting portion 416 has substantially the same diameter as the nominal diameter of the wire 402. Therefore the coil 406 is not provided so as to cover the mounting portion, but will only be attached to it by gluing, soldering or threading at the tapered section 417.

[0059] In this embodiment the recess 420 can be made deeper, and if made sufficiently narrow it will offer adequate protection for the sensor without need for any protective cover.

[0060] In this embodiment it may be difficult to attach the coil 406 as shown in FIG. 4a. Thus, in FIG. 4b there is shown an alternative design where the core wire is made to a smaller diameter and thus the thicker portion 416 has a larger diameter. The coil is pulled over the core wire, and then the wire is inserted in a proximal tube 430. As shown, the wire 402 can extend only a small distance into the tube 430. However, it may equally well extend all the way up to the proximal end of the guide wire. This embodiment of the proximal portion is also applicable to the other embodiments of the assembly disclosed herein.

[0061] In FIG. 5a a still further embodiment of the sensor and guide wire assembly 500 is shown. It also comprises a wire 502 having a distal portion with higher flexibility. This is brought about by a first relatively short (1-5 cm) tapering portion 512, continuing in a thinner portion 514, gradually becoming thinner over a distance of about 35 cm, and finally anchored in an end plug 526. However, instead of providing a thicker mounting portion, as in the embodiments of FIGS. 3 and 4, a sensor 510 is simply mounted on the thin portion 514 of the wire 502, but at the same longitudinal position. The sensor 510 is protected by a protective a recess 532 through which the medium acting on the sensor 510 will have access.

[0062] Also in this embodiment there is provided a coil 506 covering the tapering part 512 and the thinner portion 515 for providing maximum strength while still retaining high bending flexibility. The coil is attached to the tube 530 at its ends by soldering, gluing or threading or any other suitable method. Thus the coil 506 does not cover the tube 530 but rather connects to it. Also on the distal side of the tube there is provided a coil 528.

[0063] In FIG. 5b, an alternative way of anchoring the wire in the distal end plug 526 is shown. It comprises a hook shaped structure 503 which is soldered to the tip 527 of the wire 502. This alternative anchoring principle is applicable to all embodiments disclosed herein.

[0064] FIG. 6 illustrates a fisher embodiment, similar in design to the embodiment of FIG. 5, except that the sensor 610 is not protected by a tube. Instead a coil 606 is provided over the entire thinner portion 614 of the wire. The sensor 610 is mounted on the thin section 614 of the wire, and

exposure to the surrounding medium is achieved by making the windings of the coil in a spaced apart configuration.

[0065] In FIG. 7 there is shown an embodiment of a sensor and guide wire assembly wherein the sensor 710 is mounted on a thinner section on 714 of the wire 702, and the entire assembly is embedded in polymer, which thus forms the external surface of the guide wire.

[0066] As indicated, it is to be understood that the different variations of components or functions of the illustrated embodiments are interchangeable between the overall assemblies as illustrated in FIGS. 3-7.

[0067] Matching of wires and tubes to desired shapes and structures is preferably made by spark machining, although etching or possibly photo lithographic techniques may be used.

[0068] It is to be understood that any type of resonance sensor according to the definition given previously herein, may be employed, as long as the desired functionality is achieved

[0069] One such prior art sensor that may be utilized in the system according to the present invention is disclosed in U.S. Pat. Nos. 5,808,210 and 5,747,705 (W. R. Herb et al), the disclosures of which are incorporated herein in their entirety.

[0070] Below detailed descriptions of some examples of other possible sensors that may be used in the system and method of the invention will be given with reference to FIGS. 8a-e.

[0071] One preferred embodiment of a sensor element 800 according to the invention is shown in FIGS. 8a-8e. The sensor element 800 of FIGS. 8a-8e responds to pressure. FIG. 8a corresponds to a perspective view, of the sensor element 800. FIGS. 8b and 8c show a cross-section of the sensor element 800 including a cross-section of a beam element 836, without and with pressure being applied to the element, respectively. FIGS. 8d and 8e show another cross-section of the sensor element 800, including a cross-section of another beam element 838, without and with pressure being applied to the element, respectively.

[0072] Thus, The sensor element 800 is comprised preferably of a silicon die. The sensor element 800 should be designed and fabricated for the specific purpose of modulating or redistributing the incident power of an acoustic or electromagnetic wave. Moreover, the sensor element 800 should allow one of several variables, for example, temperature, pressure or flow, to be accessed and determined using a device outside of the body, that is, located externally from the human or animal tissue. An advantageous simple acoustic modulator comprises a mechanical resonator using an elastic spring element combined with a mass element. The spring element preferably comprises a thin silicon diaphragm 816 that defines a cavity 820.

[0073] The top surface of the silicon die has a thin diaphragm 816 and two beam elements 836, 838. The beam elements 836, 838 are attached to the diaphragm by suspensions 840a-d at two points for each beam element 836, 838. The silicon substrate and the diaphragm enclose a cavity 820 to define a reference pressure for the pressure sensing element 800. The cavity 820 is preferably evacuated and hermetically sealed, allowing the sensor element 800 to measure absolute pressure.

[0074] The sensor element **800** preferably is $0.15 \times 0.15 \times 0.10$ mm and is advantageously comprised, for the most part, of a silicon die, fabricated from a full wafer by batch processing. The die is constructed using techniques generally known as silicon surface micro-machining, including, lithography, material deposition, etching, or the like.

[0075] The diaphragm **816** preferably has a thickness of 1 to 2 μm and lateral dimensions of $100 \times 100 \mu\text{m}$. The beam elements **836**, **838**, preferably, are thin, narrow polysilicon structures subjected to elongation strain, which can be controlled during deposition. The beam elements **836**, **838** preferably are 0.5-1 μm thick, 1-3 μm wide, and 30-50 μm long.

[0076] As seen in FIGS. **8c** and **8e**, when pressure is applied, the elongation strains of beam elements **836**, **838** will decrease and increase, respectively, due to the positions of the suspensions **840a-840d** and the characteristic bending movement of the diaphragm **816**. The characteristic bending movement of the diaphragm **816** results from the pressure difference, ΔP , over the diaphragm **816**.

[0077] The beam elements **836**, **838**, define mechanical resonating elements. The resonance frequency of each beam element **836**, **838** is determined by its elongation strain, which is analogous to a violin string. As seen in FIG. **8c**, when pressure is applied, the tension of the beam element **836** decreases resulting in decreased resonance frequency. The opposite relationship results for beam element **838**. The quality factor of the resonance frequencies may be very high because the vibrations may operate in vacuum.

[0078] If the diaphragm **816** is subjected to periodic pressure variations from an incident ultrasonic wave, as described above, the diaphragm **20** will vibrate at the same frequency. If this frequency is very close to the resonance frequency of the beam element **836** or **838**, then sustained oscillations of high amplitude will be induced in beam **836** or **838**. If the incident ultrasonic power is then abruptly shut off, then the oscillations will persist and decay at a rate determined by the quality factor of the beam resonator. The beam resonator is also coupled to the diaphragm **816**, which is connected to the surrounding tissue, thus, the beam oscillations will be radiated somewhat as ultrasound power. As a result, it is possible to detect the beam oscillations at a location that is remote from the sensor element **800**.

[0079] Accordingly, the beam elements **836**, **838** can be considered as temporary storage elements of acoustic power. When excited at a frequency close to the free oscillating frequency, or the resonance frequency, energy will be stored. The storage capacity is determined by the quality factor, and so is the rate of dissipation after the external ultrasonic source has been cut. In the sensor element of FIG. **8**, the pressure information is coded as frequency, because the resonance frequency of beam elements **836**, **838** is a function of pressure. The quality factor Q can also be used as the information carrier, rather than the frequency.

[0080] In another embodiment, the beam elements **836**, **838** have different resonance frequencies. Different transducers having different operating frequencies, therefore, may be used to excite the beam elements **836**, **838**. One advantage of this arrangement is a resulting higher output signal level and sensitivity due to two measurements being taken rather than a single measurement. Another advantage

is that, any common spurious factor will have a decreased effect on the efficacy of the system. One such spurious factor, in some instances, is temperature. Temperature can have a negative influence on the system for example, when the device was calibrated at room temperature, but the measurements are being taken at body temperature. Accordingly, it is necessary to compensate for the temperature drift of the pressure sensing elements **800**. The compensation is easy when the sensor element **800** has two beam elements **836**, **838** that have opposite sensitivity.

[0081] Another embodiment of the sensor element **800**, includes a beam element that has a relatively constant elongation strain, even when the diaphragm **816** is bent. A beam element according to this arrangement is insensitive to pressure. The resonance frequency of such a beam element is a function of temperature resulting from a finite difference in a temperature coefficient of expansion between the materials used to construct the diaphragm and the beam elements. For example, the diaphragm may be made from single crystalline silicon and the beam may be made from polycrystalline silicon, which creates a temperature coefficient of expansion differential. It is possible, therefore, to use the sensor element **800** to measure pressure or temperature, or both, by simply design the sensor element **800** in an appropriate manner. It is also possible to use the same sensor **800** to measure flow based on the principles of thermodilution.

[0082] Another embodiment of the sensor element **800** invention is shown in FIG. **9**. The sensor element **900** has a diaphragm **916** and a beam element **942** attached to the diaphragm **916** by suspensions **944a**, **944b**. The beam element **942** of FIG. **9** functions in a somewhat different manner as compared to beam elements **836**, **838** of FIG. **8**, in which the resonating frequency is a function of the elongation strain of the beam elements **836**, **938**. The beam element **942** of FIG. **9**, on the other hand, has a rectangular cross section with a preferable width to thickness ratio of 5 or more. The beam element **942** is formed generally in an 'S'-shape, i.e., following a more or less curved line between the suspensions, thereby subjecting the beam element **942** to torsional strain when the diaphragm is subjected to external pressure. This property, in turn results in a pressure dependence for resonant torsional vibrations. One advantage of the sensor element **800** of FIG. **0** over the sensor element **800** of FIG. **8** is that, to operate as a pressure dependent resonator, no internal strain is required. In all other respects, beam element **942** operates in the same manner as beam elements **836**, **838**.

[0083] Further sensor structures and manufacture thereof, usable for the purpose of this invention are disclosed in U.S. patent application Ser. No. _____, assigned to the same assignee as the present application and filed on the same day.

[0084] Yet another embodiment of the invention is shown in FIG. **10a**. FIG. **10b** shows a particular vibration mode **1048** of a stiffening element **1046**. In FIG. **10a**, the pressure sensor element **1000** has a diaphragm **1016** as in the embodiments of FIGS. **8** and **9**. The diaphragm **1016** incorporates a stiffening element **1046** that preferably is comprised of an area with increased diaphragm thickness. In a preferred embodiment, the element **1046** has a trapezoidal shape to augment a particular vibration mode **1048** of the diaphragm, as shown in FIG. **10b**, and to make this particular resonance frequency sensitive to pressure variations, which is analo-

gous to the aforementioned dependencies with respect to **FIGS. 8 and 9**. The vibration mode **1048** corresponds to a second order resonance frequency that can also be excited by ultrasonic waves impinging on the diaphragm **1016**. An advantage of the embodiment of **FIG. 10a** is that no separate beam elements are required to create a pressure dependent resonator.

[0085] **FIG. 11** shows two schematic drawings or circuit diagrams of resonator structures. A mechanical resonator network is shown in **FIG. 11a** and comprises two coupled resonators, having two mass-spring pairs, characterized by masses M_1 , M_2 and spring constants k_1 , k_2 . Referring to **FIG. 9**, one of the resonators corresponds to beam element **942**, and the other resonator corresponds to the diaphragm **916**. The beam element **942** is characterized by its torsional spring constant and its moment of inertia for torsional motion. The diaphragm **916** is characterized by its mass and bending stiffness. According to the elementary theory of second order vibration systems, a mechanical resonator of mass M and spring constant k has a resonance frequency f_{om} defined by

$$f_{om} = \frac{1}{2\pi} \sqrt{k/M} \quad (1)$$

[0086] Two weakly coupled resonators operating at different frequencies may be treated as mutually independent elements, which is one possible operational mode for sensor element **900** of **FIG. 9**. It is preferable to adjust the mass and stiffness of diaphragm **916** so that its resonant frequency is considerably higher than the resonance frequency of the beam **942**. Thus, the mutual dependence of the resonances will be minimal. The diaphragm **916** operates within its flat frequency range, and the resonant oscillations solely depend on the pressure sensitive beam element **942**. In some cases, however, it is advantageous to utilize the opposite condition, for example, to optimize power transfer to and from the resonator. For example, if the measured variable is coded as the quality factor Q of one of the resonators, it is advantageous to use two strongly coupled resonators operating at equal or nearly equal frequencies. Using the quality factor Q as the information carrying parameter is advantageous for temperature measurements, because the quality factor Q often strongly depends on temperature.

[0087] An embodiment of the sensor element **900**, in which electromagnetic resonators are used, is shown in **FIG. 11b**. The electromagnetic resonators consist of an L-C network having two capacitors C_1 , C_2 and two inductors L_1 , L_2 . This arrangement is wholly analogous to a mechanical resonator structure. The corresponding resonance frequency f_{oe} for an L-C resonator is

$$f_{oe} = \frac{1}{2\pi} \sqrt{1/LC} \quad (2)$$

[0088] The capacitance C of a parallel plate capacitor is

$$C = Ae\epsilon_0/d \quad (3)$$

[0089] where A is the area of the plate, e , ϵ_0 are the permittivity constants, and d is the distance between the plates. If one of the capacitor plates is a diaphragm of the kind shown in **FIGS. 3 and 4**, then its pressure-induced bending causes a variation of the capacitance, which, in turn, generates a change in the resonance frequency f_{oe} . Accordingly, a pressure sensor element having one or two L-C electromagnetic resonators responds to pressure analogously to the aforementioned mechanical resonator.

[0090] In the electromagnetic embodiment shown in **FIG. 11b**, the two L-C resonators are mutually coupled, which is analogous to the resonators M_1k_1 and M_2k_2 of **FIG. 6a**. Furthermore, a certain coupling to the ambient medium is necessary to ensure that incident electromagnetic waves induce oscillations in the L-C resonator, which carry information about the physiological variable to be measured. Likewise, a certain coupling is necessary to enable detection, via external means, of the free, sustained oscillations of the resonator after the incident electromagnetic wave has been cut. In **FIG. 11b**, an antenna **1150** couples the L-C network and the ambient medium.

[0091] In both the mechanical and the electromagnetic arrangements, at least one of the resonators must have a high quality factor Q . Otherwise, it may not be possible to detect the free oscillations, because of interference from scattering and reflecting of the primary incident wave. In practice, it is preferable that the quality factor Q be greater than 10. In high performance systems, the quality factor is preferably about 100. Higher Q factors are more easily realized in mechanical resonators operating in vacuum than in electromagnetic ones. Acoustic and mechanical implementations of the system are, therefore, preferred in applications that require high performance systems.

[0092] Typical waveforms for excitation and detection are shown in **FIGS. 12a and 12b**, respectively. The excitation waveform is a burst of sine waves. In an acoustic/mechanical system, a preferable excitation frequency is 1 MHz, and the burst consists of 10-1000 periods, depending on the quality factor Q of the resonator. A larger number of periods is more desired when the quality factor Q is high, because a larger oscillation amplitude is induced. **FIG. 12b** depicts such a buildup of the oscillations. When the external power source causing excitation is switched off, power will be emitted from the resonator and decays at a rate also determined by the quality factor Q . The frequency of the free oscillations f_o is equal to the resonance frequency of the resonator. These oscillations are detectable externally, because power is partially radiated as a result of the coupling between the resonator and the ambient medium.

[0093] The burst of sine waves according to **FIG. 12** is followed by a relaxation period until the next burst. The relaxation periods are preferably longer than the duration of the bursts.

[0094] Another embodiment of the sensor and guide wire assembly is shown in **FIG. 13**. This embodiment is preferable in situations where the sensor element **1300** is permanently or temporarily implanted in the patient's body. The sensor element **1300** may be placed in the patient on a long-term basis, for example, to monitor intrauterine, intraurinary pressure. For long-term applications, the sensor element **1300** is permanently attached to a tubular element **1352** that temporarily encloses the guidewire **1310**. The embodiment also includes a catheter **1354** having a relatively large inner diameter, to enclose both a thinner catheter **1356** and the tubular element **1352**, which includes the sensor element **1300**, the guidewire **1310**, and fixing spring elements **1358**. The fixing spring elements **1358** are permanently attached to the tubular element **1352**. The thinner catheter **1356** also encloses the guidewire **1310**, but its inner diameter, preferably, is not sufficient to enclose the tubular element **1352**. When the guidewire **1310** is with-

drawn (to the left in FIG. 13), the tubular element containing the sensor 1300 is detached and left in place. The fixing elements 1358, preferably comprising spring wires will keep the tubular element 1352 in a fixed radial position against, for example, the walls of a body fluidic chamber, such as an intracranial cavity, the uterine, or the urinary bladder.

[0095] In FIG. 14 there is shown an embodiment of a sensor exhibiting electromagnetic resonance. It comprises a silicon substrate 1402 on which there has been provided an insulating first layer 1404 of silicon dioxide. On top thereof is a second layer 1406 of e.g. silicon, that may be applied by direct bonding. In the second layer there has been formed a cavity 1410 such that a thin diaphragm 1408 is formed covering the cavity, which is evacuated. This diaphragm 1408 and the substrate 1402 form members of a parallel plate capacitor. When the diaphragm is subjected to pressure, it is deflected, thus causing a change in capacitance of the capacitor. To complete the L-C circuit an inductor 1412 is connected across the plates. i.e. the substrate 1402 and the diaphragm 1408.

[0096] Additional advantages and modifications will readily occur to those skilled in the art. Therefore, the invention in its broader aspects is not limited to the specific details, and representative devices, shown and described herein. Accordingly, various modifications may be made without departing from the spirit or scope of the general inventive concept as defined by the appended claims and their equivalents.

What is claimed is:

1. A system for measuring a physiological variable in vivo in a human or animal body, comprising

a sensor device responsive to said physiological variable, comprising at least one mechanical resonant member, a property of which changes in response to the influence of said physiological variable,

a transmitter of ultrasound power for exciting said resonant member through body tissue to cause said resonant member to enter into a resonating state,

a receiver for recording a resonance signal emitted from said resonant member.

2. The system according to claim 1, wherein said property is the resonance frequency.

3. The system according to claim 2, wherein the resonance frequency of said resonant member is a monotonous function of said variable in at least one interval.

4. The system according to claim 1, wherein said property is the quality factor of said resonant member(s), and which is a monotonous function of said variable in at least one interval.

5. The system according to claim 1 wherein said transmitter is provided with ultrasound power burst transmitting means, providing bursts of finite duration followed by periods of silence, said periods of silence having a longer duration than said bursts.

6. The system according to claim 5 wherein said bursts consist of sinusoidal waves with a number of periods in the interval 10 to 1000.

7. The system according to claim 1, comprising at least one electronic drive and detection unit connected to said transmitter and receiver, and adapted to provide said transmitter with driving power of preselected duration, amplitude

and frequency, and to provide the receiver with amplifying and signal analyzing capacity.

8. The system according to claim 1, wherein said sensor element is an incident ultrasonic power scattering element.

9. The system according to claim 2, adapted to transmit and receive ultrasonic waves in a frequency range of 0.1-10 MHz.

10. The system according to claim 1, wherein said sensor device is mounted on a guide wire for insertion into said body.

11. A sensor and guide wire assembly for localized measurements of physiological variables within a human or animal body, comprising:

a guide wire;

a sensor element, attached to said guide wire in the vicinity of the distal end thereof, and responsive to externally applied power by emitting a signal representative of said physiological variable, said signal being detectable by means located externally of the body, without physical connection to said sensor element.

12. The sensor and guide wire assembly according to claim 11, wherein said guide wire comprises a core wire including at least two sections, each having different bending flexibility, said flexibility being highest in the section in the vicinity of the distal end of said wire.

13. The sensor and guide wire assembly according to claim 11, wherein said sensor is adapted to detect physiological variables including pressure, flow and temperature.

14. The sensor and guide wire assembly according to claim 11, wherein said sensor element comprises at least one resonating element, the resonance frequency of which is a monotonous function of the variable to be measured.

15. The sensor and guide wire assembly according to claim 14 wherein said sensor element includes at least one mechanical resonator element.

16. The sensor and guide wire assembly according to claim 14 wherein said sensor element includes at least one electromagnetic resonator element.

17. The sensor and guide wire assembly according to claim 11, wherein said resonating element is coupled to a diaphragm, the static deflection of which is a function of hydrostatic pressure.

18. The sensor and guide wire assembly according to claim 11 wherein said sensor element includes at least one closed cavity, defining a pressure reference.

19. The sensor and guide wire assembly according to claim 11 wherein said wire is made from, noncorrosive and biocompatible metallic materials selected from the group consisting of stainless steel, memory metal, titanium, tungsten or platinum.

20. The sensor and guide wire assembly according to claim 11, comprising at least one coil wrapped around at least a portion of the distal end of said wire.

21. The sensor and guide wire assembly for measuring physiological variables as claimed in claim 11, wherein said sensor element comprises a silicon die.

22. The sensor and guide wire assembly for measuring physiological variables as claimed in claim 11 wherein said sensor element comprises a diaphragm defining a cavity.

23. The sensor and guide wire assembly for measuring physiological variables as claimed in claim 22, wherein said sensor element further comprises at least one beam element.

24. The sensor and guide wire assembly for measuring physiological variables as claimed in claim 23, wherein said sensor element has a plurality of beam elements attached to said diaphragm.

25. The sensor and guide wire assembly for measuring physiological variables as claimed in claim 24, wherein said plurality of beam elements are attached to said diaphragm by a corresponding plurality of suspensions.

26. The sensor and guide wire assembly for measuring physiological variables as claimed in claim 24, wherein a resonance frequency of at least two of said beam elements is different.

27. The sensor and guide wire assembly for measuring physiological variables as claimed in claim 24, wherein a resonance frequency of at least two of said beam elements is the same.

28. The sensor and guide wire assembly for measuring physiological variables as claimed in claim 11, wherein said sensor element comprises at least one beam element having a constant elongation strain.

29. The sensor and guide wire assembly for measuring physiological variables as claimed in claim 11, wherein said sensor element comprises a diaphragm and a beam element attached to said diaphragm.

30. The sensor and guide wire assembly for measuring physiological variables as claimed in claim 29, wherein said beam element is generally 'S'-shaped.

31. The sensor and guide wire assembly for measuring physiological variables as claimed in claim 30, wherein said beam element is subject to a torsional strain when said diaphragm is subject to an external pressure.

32. The sensor and guide wire assembly for measuring physiological variables as claimed in claim 11, wherein said sensor element comprises a diaphragm and a stiffening element on said diaphragm.

33. The sensor and guide wire assembly for measuring physiological variables as claimed in claim 11, wherein said stiffening element is shaped as a trapezoid.

34. The sensor and guide wire assembly for measuring physiological variables as claimed in claim 11, wherein said sensor element comprises at least one L-C network.

35. The sensor and guide wire assembly for measuring physiological variables as claimed in claim 34, wherein said L-C network comprises two capacitors and two inductors.

36. The sensor and guide wire assembly for measuring physiological variables as claimed in claim 11, wherein said sensor element comprises at least one resonator having a quality factor greater than 10.

37. The sensor and guide wire assembly for measuring physiological variables as claimed in claim 11, wherein said sensor element comprises at least one resonator having a quality factor greater than 100.

38. The sensor and guide wire assembly for measuring physiological variables as claimed in claim 11, wherein said sensor element is attached to a tubular element enclosing said guidewire.

39. The sensor and guide wire assembly for measuring physiological variables as claimed in claim 38, further comprising a catheter enclosing said tubular element.

40. A sensor and guide wire assembly for measuring physiological variables, comprising:

a guide wire having a proximal end and a distal end;

a sensor element attached to said guide wire nearer to said distal end than to said proximal end; and

wireless means for communicating information and power.

41. The sensor and guide wire assembly for measuring physiological variables as claimed in claim 40, wherein said sensor element includes at least one mechanical resonator element.

42. The sensor and guide wire assembly for measuring physiological variables as claimed in claim 41, wherein said at least one mechanical resonator element is acoustically coupled to an external acoustic wave.

43. The sensor and guide wire assembly for measuring physiological variables as claimed in claim 40, further comprising at least one electromagnetic resonator element.

44. The sensor and guide wire assembly for measuring physiological variables as claimed in claim 43, wherein said at least one electromagnetic resonator element is electromagnetically coupled to an external electromagnetic wave.

45. The sensor and guide wire assembly for measuring physiological variables as claimed in claim 40, wherein said sensor element includes a resonating element coupled to a diaphragm.

46. The sensor and guide wire assembly for measuring physiological variables as claimed in claim 45, wherein a static deflection of said diaphragm is a function of hydrostatic pressure.

47. The sensor and guide wire assembly for measuring physiological variables as claimed in claim 40, wherein said sensor element defines at least one closed cavity that defines a pressure reference.

48. The sensor and guide wire assembly for measuring physiological variables as claimed in claim 40, wherein said sensor element includes a first and a second resonator.

49. The sensor and guide wire assembly for measuring physiological variables as claimed in claim 48, wherein said second resonator is acoustically coupled to an ambient medium.

50. The sensor and guide wire assembly for measuring physiological variables as claimed in claim 48, wherein said first and second resonators are mutually coupled.

51. The sensor and guide wire assembly for measuring physiological variables as claimed in claim 40, wherein said sensor element comprises at least one mechanical resonator, wherein a resonance frequency of said at least one mechanical resonator is a function of temperature.

52. The sensor and guide wire assembly for measuring physiological variables as claimed in claim 40, further comprising at least one capacitor and at least one inductor mounted to said sensor element.

53. The sensor and guide wire assembly for measuring physiological variables as claimed in claim 40, wherein said sensor element comprises an inductive and capacitive network, and wherein a resonance frequency of said inductive and capacitive network is a function of at least one of said physiological variables.

54. The sensor and guide wire assembly for measuring physiological variables as claimed in claim 40, further comprising means for disassembly of a tubular member from said guidewire, allowing said sensor element to be implanted in the patient.

55. The sensor and guide wire assembly for measuring physiological variables as claimed in claim 40, further comprising means for fixing of said sensor element to be implanted inside said body.

56. A method for measuring physiological variables; comprising the steps of:

- (a) inserting a guidewire into a patient's body;
- (b) transmitting waves to a sensor mounted on said guidewire;
- (c) causing said sensor to resonate said waves, said resonance being a function of a physiological variable; and
- (c) receiving resonance waves.

57. A method for measuring physiological variables as claimed in claim 56 further comprising the step of analyzing said resonance waves.

58. A method for measuring physiological variables as claimed in claim 56, wherein said waves are transmitted through the body to the sensor, and said waves are redistributed by the sensor and received external to the body.

59. A method for measuring physiological variables as claimed in claim 56, further comprising the step of (e) ceasing transmitting waves.

60. A method for measuring physiological variables as claimed in claim 59, wherein steps (a) through (e) are repeated at least once.

61. A method for measuring physiological variables as claimed in claim 66, wherein said ceasing step is longer in duration than said transmitting step.

62. A sensor device responsive to a physical variable, comprising at least one mechanically resonant members the resonant frequency of which changes in response to the influence of said physical variable, said resonant member being excitable by external means without physical connections to said sensor device, and said resonance frequency of said resonant member being detectable by a receiver without physical connections to said sensor device.

63. The sensor device of claim 62, further comprising a substrate, a cavity, a diaphragm covering said cavity, said acoustically resonant member(s) being a beam structure attached to said diaphragm by suspensions.

64. The sensor device of claim 63, wherein said beam structure(s) is/are thin and narrow polysilicon structures.

65. The sensor device of claim 64, wherein the dimensions of said beam structure(s) are 0.5-3 μm in thickness, 1-3 μm in width, and 10-50 μm in length.

66. The sensor device of claim 64, wherein the beam structures are essentially straight.

67. The sensor device of claim 63, wherein the beam structure(s) are S-shaped.

68. The sensor device of claim 62, further comprising a substrate, a cavity, a diaphragm covering said cavity, wherein said acoustically resonant member(s) is the diaphragm itself.

69. The sensor device of claim 62, wherein said diaphragm is provided with a stiffening element.

70. The sensor device of claim 69, wherein said stiffening element is an area of the diaphragm with increased thickness.

71. The sensor device of claim, **69**, wherein said stiffening element has a trapezoidal shape.

72. A method of measuring a physical variable, comprising

providing a sensor device responsive to said physical variable at a measurement location, said sensor device comprising at least one resonant member, the resonance frequency of which changes in response to a change in said physical variable;

transmitting ultrasound energy from a source to said sensor device for exciting said resonant member;

exposing said sensor device to an environment where said physical variable is to be measured;

detecting the resonance frequency of said resonant member by a receiver located outside the body without physical connections to said sensor device.

73. The method of claim 12, wherein the measurement is performed in vivo in a human or animal body.

74. The method of claim 72, wherein the physical variable is selected from the group consisting of pressure, temperature and flow of a fluid.

75. The method of claim 73, wherein the sensor device is instead in said body by means of a guide wire, the sensor being attached at the distal end of said guide wire.

76. The method of claim 72, wherein the excitation energy is selected from acoustic energy and electromagnetic energy.

77. A sensor and guide wire assembly, comprising

a core wire having a high and a low flexible sections the low flexible section being located at the distal end of the core wire;

a thicker portion forming part of said high flexible section;

a slot formed in said thicker portion;

a resonance sensor mounted in said slot;

a coil wrapped around said high flexible section, but leaving an opening over a portion of said slot to expose the sensor.

78. A sensor and guide wire assembly, comprising

a core wire having a high and a low flexible section, the low flexible section being located at the distal end of the core wire;

a thicker portion forming part of said high flexible section, and having the same outer diameter as the low flexible section of said core wire;

a slot formed in said thicker portion;

a resonance sensor mounted in said slot;

a coil wrapped around said high flexible section, except for said thicker portion, and such that the outer diameter of the entire assembly is essentially equal over the length of the guide wire.

79. A sensor and guide wire assembly, comprising

a core wire having a high and a low flexible section, the low flexible section being located at the distal end of the core wire;

a resonance sensor mounted on the core wire at said high flexible section thereof;

a protective tube enclosing said sensor and provided with an opening disposed over a portion of said sensor;

a coil wrapped around said high flexible section, attached to said tube such that the outer diameter of the entire assembly is essentially equal over the length of the guide wire.

80. A sensor and guide wire assembly, comprising

a core wire having a high and a low flexible section, the low flexible section being located at the distal end of the core wire;

a resonance sensor mounted on the core wire at said high flexible section thereof;

a coil wrapped around said high flexible section, but leaving an opening over fraction of said section to expose the sensor.

81. A sensor and guide wire assembly, comprising

a core wire having a high and a low flexible section, the low flexible section being located at the distal end of the core wire;

a resonance sensor mounted on the core wire at said high flexible section thereof;

a polymer wrapping completely enclosing both the high and low flexible sections of the core wire, such that the core wire is embedded in polymer, which thus forms the external surface of the guide wire.

* * * * *

专利名称(译)	用于生理变量的无线测量的方法和传感器		
公开(公告)号	US20020013527A1	公开(公告)日	2002-01-31
申请号	US09/949951	申请日	2001-09-12
[标]申请(专利权)人(译)	霍克贝蒂尔 TENERZ LARS HAMMARSTROEM OLA BENKOWSKI PER MALMBORG PAER VON		
申请(专利权)人(译)	霍克贝蒂尔 TENERZ LARS HAMMARSTROEM OLA BENKOWSKI PER MALMBORG PAER VON		
当前申请(专利权)人(译)	ST.犹达医疗协调中心BVBA		
[标]发明人	HOEK BERTIL TENERZ LARS HAMMARSTROEM OLA BENKOWSKI PER MALMBORG PAER VON		
发明人	HOEK, BERTIL TENERZ, LARS HAMMARSTROEM, OLA BENKOWSKI, PER MALMBORG, PAER VON		
IPC分类号	A61B5/00 A61B8/08 A61B8/00		
CPC分类号	A61B5/0031 A61B5/6851 A61B8/0833 A61B8/4472		
其他公开文献	US6517481		
外部链接	Espacenet USPTO		

摘要(译)

具有传感器元件的传感器和导丝组件插入患者体内。然后，声波或电磁波从外部源朝向传感器元件发射。传感器元件接收入射波并进入共振状态。共振的特征对应于要测量的变量或变量。换能器位于患者身体外部并接收散射波并将得到的信号转移到电子驱动器末端检测单元以进行信号分析。

