



US009351658B2

(12) **United States Patent**  
**Lee et al.**

(10) **Patent No.:** **US 9,351,658 B2**  
(45) **Date of Patent:** **May 31, 2016**

(54) **DEVICE AND METHOD FOR SENSING ELECTRICAL ACTIVITY IN TISSUE**

(75) Inventors: **Michael J. Lee**, Carmel, CA (US); **Hans C. Lee**, Carmel, CA (US)

(73) Assignee: **The Nielsen Company (US), LLC**, Schaumburg, IL (US)

(\* ) Notice: Subject to any disclaimer, the term of this patent is extended or adjusted under 35 U.S.C. 154(b) by 86 days.

(21) Appl. No.: **11/500,678**

(22) Filed: **Aug. 8, 2006**

(65) **Prior Publication Data**  
US 2007/0055169 A1 Mar. 8, 2007

**Related U.S. Application Data**

(60) Provisional application No. 60/713,899, filed on Sep. 2, 2005.

(51) **Int. Cl.**  
*A61B 5/0476* (2006.01)  
*A61B 5/04* (2006.01)  
*A61B 5/048* (2006.01)  
*A61B 5/00* (2006.01)

(52) **U.S. Cl.**  
CPC ..... *A61B 5/0476* (2013.01); *A61B 5/0006* (2013.01); *A61B 5/048* (2013.01); *A61B 5/6814* (2013.01); *A61B 5/0002* (2013.01)

(58) **Field of Classification Search**  
CPC .... *A61B 5/0476*; *A61B 5/0478*; *A61B 5/048*; *A61B 5/0482*; *A61B 5/0484*  
USPC ..... 600/544, 545, 546; 128/925  
See application file for complete search history.

(56) **References Cited**

U.S. PATENT DOCUMENTS

4,695,879 A	9/1987	Weinblatt	
4,755,045 A	7/1988	Borah et al.	
4,846,190 A *	7/1989	John .....	600/544
4,931,934 A	6/1990	Snyder	
4,974,602 A	12/1990	Abraham-Fuchs et al.	
5,024,235 A *	6/1991	Ayers .....	600/545
5,243,517 A	9/1993	Schmidt et al.	
5,406,957 A	4/1995	Tansey	
5,447,166 A	9/1995	Gevins	
5,450,855 A	9/1995	Rosenfeld	
5,513,649 A	5/1996	Gevins et al.	
5,579,774 A	12/1996	Miller et al.	

(Continued)

FOREIGN PATENT DOCUMENTS

EP	1052582	11/2000
EP	1389012	2/2004

(Continued)

OTHER PUBLICATIONS

Egner, Tobias; Emilie Strawson, and John H Gruzelier. "EEG Signature and Phenomenology of Alpha/theta Neurofeedback Training Versus Mock Feedback." *Applied Psychophysiology and Biofeedback*. vol. 27, No. 4. Dec. 2002.\*

(Continued)

*Primary Examiner* — Adam J Eiseman

(74) *Attorney, Agent, or Firm* — Hanley, Flight & Zimmerman, LLC

(57) **ABSTRACT**

An exemplary embodiment providing one or more improvements includes apparatus and methods for sensing electrical activity in tissue of a person in a manner which is substantially limits or eliminates interference from noise in a surrounding environment.

**41 Claims, 7 Drawing Sheets**

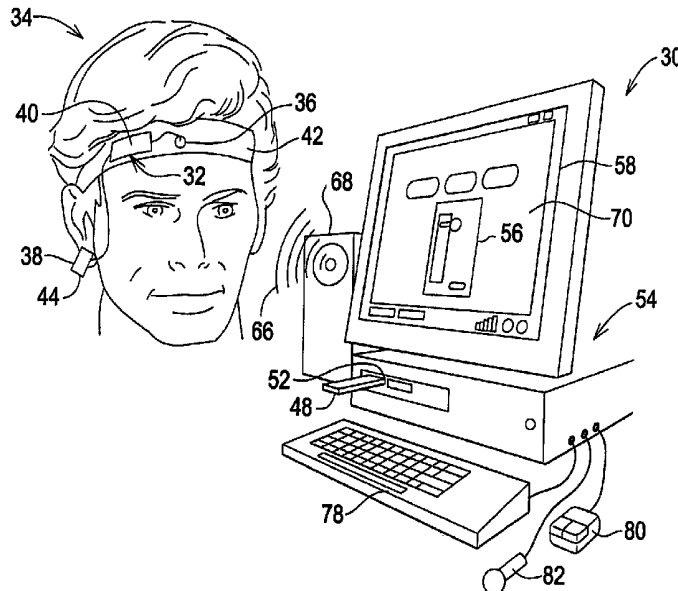

(56)

## References Cited

## U.S. PATENT DOCUMENTS

5,601,090	A	2/1997	Musha		2003/0081834	A1	5/2003	Philomin et al.
5,649,061	A	7/1997	Smyth		2003/0093784	A1	5/2003	Dimitrova et al.
5,676,138	A	10/1997	Zawilinski		2003/0126593	A1	7/2003	Mault
5,692,906	A	12/1997	Corder		2003/0153841	A1	8/2003	Kilborn et al.
5,724,987	A	3/1998	Gevins et al.		2004/0013398	A1	1/2004	Miura et al.
5,740,812	A	4/1998	Cowan		2004/0018476	A1	1/2004	Ladue
5,774,591	A	6/1998	Black et al.		2004/0039268	A1	2/2004	Barbour et al.
5,983,129	A	11/1999	Cowan et al.		2004/0072133	A1	4/2004	Kullock et al.
5,983,214	A	11/1999	Lang et al.		2004/0077934	A1	4/2004	Massad
5,995,868	A	11/1999	Dorfmeister et al.		2004/0088289	A1	5/2004	Xu et al.
6,001,065	A	12/1999	DeVito		2004/0111033	A1	6/2004	Oung et al.
6,016,444	A	1/2000	John		2004/0161730	A1	8/2004	Urman
6,099,319	A	8/2000	Zaltman et al.		2004/0193068	A1	9/2004	Burton et al.
6,117,092	A	9/2000	Weinstein et al.		2004/0208496	A1	10/2004	Pilu
6,254,536	B1	7/2001	DeVito		2004/0267141	A1	12/2004	Amano et al.
6,259,889	B1	7/2001	LaDue		2005/0010087	A1	1/2005	Banet et al.
6,270,466	B1	8/2001	Weinstein et al.		2005/0010116	A1	1/2005	Korhonen et al.
6,292,688	B1	9/2001	Patton		2005/0043774	A1	2/2005	Devlin et al.
6,309,342	B1	10/2001	Blazey et al.		2005/0045189	A1	3/2005	Jay
6,322,368	B1	11/2001	Young et al.		2005/0066307	A1	3/2005	Patel et al.
6,349,231	B1	2/2002	Musha		2005/0071865	A1	3/2005	Martins
6,422,999	B1	7/2002	Hill		2005/0096311	A1	5/2005	Suffin et al.
6,425,764	B1	7/2002	Lamson		2005/0097594	A1	5/2005	O'Donnell et al.
6,434,419	B1	8/2002	Gevins et al.		2005/0113656	A1	5/2005	Chance
6,453,194	B1	9/2002	Hill		2005/0120372	A1	6/2005	Itakura
6,481,013	B1	11/2002	Dinwiddie et al.		2005/0143629	A1	6/2005	Farwell
6,520,905	B1 *	2/2003	Surve et al. .... 600/26		2005/0165285	A1	7/2005	Iloff
6,585,521	B1	7/2003	Obrador		2005/0172311	A1	8/2005	Hjelt et al.
6,606,102	B1	8/2003	Odom		2005/0223237	A1	10/2005	Barletta et al.
6,609,024	B1	8/2003	Ryu et al.		2005/0289582	A1	12/2005	Tavares et al.
6,623,428	B2	9/2003	Miller et al.		2006/0010470	A1	1/2006	Kurosaki et al.
6,626,676	B2	9/2003	Freer		2006/0064037	A1	3/2006	Shalon et al.
6,648,822	B2	11/2003	Hamamoto et al.		2006/0094970	A1	5/2006	Drew
6,652,283	B1	11/2003	Van Schaack et al.		2006/0111621	A1	5/2006	Coppi et al.
6,656,116	B2	12/2003	Kim et al.		2006/0143647	A1	6/2006	Bill
6,678,866	B1	1/2004	Sugimoto et al.		2006/0217598	A1	9/2006	Miyajima et al.
6,699,188	B2	3/2004	Wessel		2006/0258926	A1	11/2006	Ali et al.
6,792,304	B1	9/2004	Silberstein		2006/0265022	A1	11/2006	John et al.
6,839,682	B1	1/2005	Blume		2006/0277102	A1	12/2006	Agliozzo
6,978,115	B2	12/2005	Whitehurst et al.		2006/0293608	A1 *	12/2006	Rothman et al. .... 600/545
7,035,685	B2 *	4/2006	Ryu et al. .... 600/544		2006/0293921	A1	12/2006	McCarthy et al.
7,050,753	B2	5/2006	Knutson		2007/0031798	A1	2/2007	Gottfried
7,113,916	B1	9/2006	Hill		2007/0048707	A1	3/2007	Caamano et al.
7,127,283	B2	10/2006	Kageyama		2007/0053513	A1	3/2007	Hoffberg
7,194,186	B1	3/2007	Strub et al.		2007/0055169	A1	3/2007	Lee et al.
7,246,081	B2	7/2007	Hill		2007/0060830	A1	3/2007	Le et al.
D565,735	S	4/2008	Washbon		2007/0060831	A1	3/2007	Le et al.
7,383,728	B2	6/2008	Noble et al.		2007/0066914	A1	3/2007	Le et al.
7,627,880	B2	12/2009	Itakura		2007/0116037	A1	5/2007	Moore
7,630,757	B2	12/2009	Dorfmeister et al.		2007/0168461	A1	7/2007	Moore
7,689,272	B2	3/2010	Farwell		2007/0173733	A1	7/2007	Le et al.
7,716,697	B2	5/2010	Morikawa et al.		2007/0179396	A1	8/2007	Le et al.
7,739,140	B2	6/2010	Vinson et al.		2007/0184420	A1	8/2007	Mathan et al.
7,742,623	B1	6/2010	Moon et al.		2007/0225585	A1	9/2007	Washbon et al.
7,751,878	B1	7/2010	Merkle et al.		2007/0235716	A1	10/2007	Delic et al.
7,805,009	B2	9/2010	Everett et al.		2007/0238945	A1	10/2007	Delic et al.
7,853,122	B2	12/2010	Miura et al.		2007/0249952	A1	10/2007	Rubin et al.
7,930,199	B1	4/2011	Hill		2007/0265507	A1	11/2007	De Lemos
7,942,816	B2	5/2011	Satoh et al.		2008/0039737	A1	2/2008	Breiter et al.
8,235,725	B1	8/2012	Hill		2008/0091512	A1	4/2008	Marci et al.
8,326,002	B2	12/2012	Hill		2008/0144882	A1	6/2008	Leinbach et al.
8,600,100	B2	12/2013	Hill		2008/0159365	A1	7/2008	Dubocanin et al.
2001/0016874	A1	8/2001	Ono et al.		2008/0161651	A1	7/2008	Peterson et al.
2001/0056225	A1	12/2001	DeVito		2008/0162182	A1	7/2008	Cazares et al.
2002/0103429	A1	8/2002	deCharms		2008/0177197	A1	7/2008	Lee et al.
2002/0107454	A1	8/2002	Collura et al.		2008/0201731	A1	8/2008	Howcroft
2002/0154833	A1	10/2002	Koch et al.		2008/0211768	A1	9/2008	Breen et al.
2002/0182574	A1	12/2002	Freer		2008/0218472	A1	9/2008	Breen et al.
2002/0188216	A1 *	12/2002	Kayyali et al. .... 600/544		2009/0024049	A1	1/2009	Pradeep et al.
2003/0003433	A1	1/2003	Carpenter et al.		2009/0024447	A1	1/2009	Pradeep et al.
2003/0055355	A1	3/2003	Viertio-Oja		2009/0024448	A1	1/2009	Pradeep et al.
2003/0063780	A1	4/2003	Gutta et al.		2009/0024449	A1	1/2009	Pradeep et al.
2003/0066071	A1	4/2003	Gutta et al.		2009/0024475	A1	1/2009	Pradeep et al.
2003/0067486	A1	4/2003	Lee et al.		2009/0025023	A1	1/2009	Pradeep et al.
2003/0076369	A1	4/2003	Resner		2009/0030287	A1	1/2009	Pradeep et al.
					2009/0030303	A1	1/2009	Pradeep et al.
					2009/0030717	A1	1/2009	Pradeep et al.
					2009/0030930	A1	1/2009	Pradeep et al.
					2009/0036755	A1	2/2009	Pradeep et al.

(56) **References Cited**

## U.S. PATENT DOCUMENTS

2009/0036756	A1	2/2009	Pradeep et al.
2009/0062629	A1	3/2009	Pradeep et al.
2009/0062681	A1	3/2009	Pradeep et al.
2009/0063255	A1	3/2009	Pradeep et al.
2009/0063256	A1	3/2009	Pradeep et al.
2009/0082643	A1	3/2009	Pradeep et al.
2009/0083129	A1	3/2009	Pradeep et al.
2009/0105576	A1	4/2009	Do et al.
2009/0112077	A1	4/2009	Nguyen et al.
2009/0156907	A1	6/2009	Jung et al.
2009/0156925	A1	6/2009	Jin et al.
2009/0156955	A1	6/2009	Jung et al.
2009/0163777	A1	6/2009	Jung et al.
2009/0171164	A1	7/2009	Jung et al.
2009/0214060	A1	8/2009	Chuang et al.
2009/0222330	A1	9/2009	Leinbach
2010/0076333	A9	3/2010	Burton et al.
2012/0002848	A1	1/2012	Hill
2012/0046993	A1	2/2012	Hill
2012/0289794	A1	11/2012	Jain et al.
2013/0094722	A1	4/2013	Hill
2013/0121591	A1	5/2013	Hill
2014/0039857	A1	2/2014	Hill
2014/0039975	A1	2/2014	Hill
2014/0162225	A1	6/2014	Hill

## FOREIGN PATENT DOCUMENTS

EP	1607842	12/2005
JP	05293172	11/1993
JP	07-329657	12/1995
JP	2002-000577	1/2002
JP	2002056500	2/2002
JP	2002-344904	11/2002
JP	2003-016095	1/2003
JP	2003-111106	4/2003
JP	2003-178078	6/2003
JP	2003522580	7/2003
JP	2005084770	3/2005
JP	2006-323547	11/2006
KR	10-2000-0072489	12/2000
KR	10-2001-0104579	11/2001
WO	00/17824	3/2000
WO	01/97070	12/2001
WO	2004/100765	11/2004
WO	2006005767	1/2006
WO	2007/019584	2/2007

## OTHER PUBLICATIONS

Form PCT/ISA/220, PCT/US07/15019, "PCT Notification of Transmittal of The International Search Report and the Written Opinion of the International Searching Authority, or the Declaration," 1 pg.  
 Form PCT/ISA/210, PCT/US07/15019, "PCT International Search Report," 2 pgs.  
 Form PCT/ISA/237, PCT/US07/15019, "PCT Written Opinion of the International Searching Authority," 5 pgs.  
 Form PCT/IB/326, PCT/US07/015019, "Notification Concerning Transmittal of International Preliminary Report on Patentability."  
 Form PCT/IB/373, PCT/US07/15019, "International Preliminary Report on Patentability."  
 Form PCT/ISA/220, PCT/US07/14955, "PCT Notification of Transmittal of The International Search Report and the Written Opinion of the International Searching Authority, or the Declaration," 1 pg.  
 Form PCT/ISA/210, PCT/US07/14955, "PCT International Search Report," 2 pgs.  
 Form PCT/ISA/237, PCT/US07/14955, "PCT Written Opinion of the International Searching Authority," 6 pgs.  
 Form PCT/IB/326, PCT/US07/14955, "Notification Concerning Transmittal of International Preliminary Report on Patentability," 1 page.  
 Form PCT/IB/373, PCT/US07/14955, "International Preliminary Report on Patentability," 1 page.

Form PCT/ISA/220, PCT/US07/16796, "PCT Notification of Transmittal of The International Search Report and the Written Opinion of the International Searching Authority, or the Declaration," 1 pg.  
 Form PCT/ISA/210, PCT/US07/16796, "PCT International Search Report," 2 pgs.  
 Form PCT/ISA/237, PCT/US07/16796, "PCT Written Opinion of the International Searching Authority," 6 pgs.  
 Form PCT/IB/326, PCT/US07/16796, "Notification Concerning Transmittal of International Preliminary Report on Patentability," 1 page.  
 Form PCT/IB/373, PCT/US07/16796, "International Preliminary Report on Patentability," 1 page.  
 Form PCT/ISA/220, PCT/US06/31569, "PCT Notification of Transmittal of the International Search Report and the Written Opinion of the International Searching Authority, or the Declaration," 1 pg.  
 Form PCT/ISA/210, PCT/US06/31569, "PCT International Search Report," 3 pgs.  
 Form PCT/ISA/237, PCT/US06/31569, "PCT Written Opinion of the International Searching Authority," 6 pgs.  
 Form PCT/IB/326, PCT/US06/31569, "Notification Concerning Transmittal of International Preliminary Report on Patentability," 1 page.  
 Form PCT/IB/373, PCT/US06/31569, "International Preliminary Report on Patentability," 1 page.  
 Form PCT/ISA/220, PCT/US07/20714, "PCT Notification of Transmittal of The International Search Report and the Written Opinion of the International Searching Authority, or the Declaration," 1 pg.  
 Form PCT/ISA/210, PCT/US07/20714, "PCT International Search Report," 2 pgs.  
 Form PCT/ISA/237, PCT/US07/20714, "PCT Written Opinion of the International Searching Authority," 6 pgs.  
 Form PCT/IB/326, PCT/US07/20714, "Notification Concerning Transmittal of International Preliminary Report on Patentability," 1 page.  
 Form PCT/IB/373, PCT/US07/20714, "International Preliminary Report on Patentability," 1 page.  
 Form PCT/ISA/220, PCT/US07/17764, "PCT Notification of Transmittal of The International Search Report and the Written Opinion of the International Searching Authority, or the Declaration," 1 pg.  
 Form PCT/ISA/210, PCT/US07/17764, "PCT International Search Report," 2 pgs.  
 Form PCT/ISA/237, PCT/US07/17764, "PCT Written Opinion of the International Searching Authority," 7 pgs.  
 Form PCT/IB/326, PCT/US07/17764, "Notification Concerning Transmittal of International Preliminary Report on Patentability," 1 page.  
 Form PCT/IB/373, PCT/US07/17764, "International Preliminary Report on Patentability," 1 page.  
 Form PCT/ISA/220, PCT/US07/20713, "PCT Notification of Transmittal of The International Search Report and the Written Opinion of the International Searching Authority, or the Declaration," 1 pg.  
 Form PCT/ISA/210, PCT/US07/20713, "PCT International Search Report," 2 pgs.  
 Form PCT/ISA/237, PCT/US07/20713, "PCT Written Opinion of the International Searching Authority," 5 pgs.  
 Form PCT/IB/326, PCT/US07/20713, "Notification Concerning Transmittal of International Preliminary Report on Patentability," 1 page.  
 Form PCT/IB/373, PCT/US07/20713, "International Preliminary Report on Patentability," 1 page.  
 Form PCT/ISA/220, PCT/US08/09110, "PCT Notification of Transmittal of the International Search Report and the Written Opinion of the International Searching Authority, or the Declaration," 1 pg.  
 Form PCT/ISA/210, PCT/US08/09110, "PCT International Search Report," 3 pgs.  
 Form PCT/ISA/237, PCT/US08/09110, "PCT Written Opinion of the International Searching Authority," 4 pgs.  
 Form PCT/ISA/220, PCT/US08/75640, "PCT Notification of Transmittal of The International Search Report and the Written Opinion of the International Searching Authority, or the Declaration," 1 pg.  
 Form PCT/ISA/210, PCT/US08/75640, "PCT International Search Report," 2 pgs.

(56)

## References Cited

## OTHER PUBLICATIONS

Form PCT/ISA/237, PCT/US08/75640, "PCT Written Opinion of the International Searching Authority," 3 pgs.

Form PCT/ISA/220, PCT/US08/78633, "PCT Notification of Transmittal of The International Search Report and the Written Opinion of the International Searching Authority, or the Declaration," 1 pg.

Form PCT/ISA/210, PCT/US08/78633, "PCT International Search Report," 2 pgs.

Form PCT/ISA/237, PCT/US08/78633, "PCT Written Opinion of the International Searching Authority," 6 pgs.

Form PCT/ISA/220, PCT/US08/82147, "PCT Notification of Transmittal of The International Search Report and the Written Opinion of the International Searching Authority, or the Declaration," 1 pg.

Form PCT/ISA/210, PCT/US08/82147, "PCT International Search Report," 2 pgs.

Form PCT/ISA/237, PCT/US08/82147, "PCT Written Opinion of the International Searching Authority," 13 pgs.

Form PCT/ISA/220, PCT/US08/82149, "PCT Notification of Transmittal of The International Search Report and the Written Opinion of the International Searching Authority, or the Declaration," 1 pg.

Form PCT/ISA/210, PCT/US08/82149, "PCT International Search Report," 2 pgs.

Form PCT/ISA/237, PCT/US08/82149, "PCT Written Opinion of the International Searching Authority," 14 pgs.

Form PCT/ISA/220, PCT/US08/75651, "PCT Notification of Transmittal of The International Search Report and the Written Opinion of the International Searching Authority, or the Declaration," 1 pg.

Form PCT/ISA/210, PCT/US08/75651, "PCT International Search Report," 2 pgs.

Form PCT/ISA/237, PCT/US08/75651, "PCT Written Opinion of the International Searching Authority," 9 pgs.

Form PCT/ISA/220, PCT/US08/85723, "PCT Notification of Transmittal of The International Search Report and the Written Opinion of the International Searching Authority, or The Declaration," 1 pg.

Form PCT/ISA/210, PCT/US08/85723, "PCT International Search Report," 2 pgs.

Form PCT/ISA/237, PCT/US08/85723, "PCT Written Opinion of the International Searching Authority," 7 pgs.

Form PCT/ISA/220, PCT/US08/85203, "PCT Notification of Transmittal of The International Search Report and the Written Opinion of the International Searching Authority, or The Declaration," 1 pg.

Form PCT/ISA/210, PCT/US08/85203, "PCT International Search Report," 2 pgs.

Form PCT/ISA/237, PCT/US08/85203, "PCT Written Opinion of the International Searching Authority," 6 pgs.

Form PCT/ISA/220, PCT/US08/75649, "PCT Notification of Transmittal of The International Search Report and the Written Opinion of the International Searching Authority, or the Declaration," 1 pg.

Form PCT/ISA/210, PCT/US08/75649, "PCT International Search Report," 3 pgs.

Form PCT/ISA/237, PCT/US08/75649, "PCT Written Opinion of the International Searching Authority," 5 pgs.

Technology Platform: SmartShirt + Eye-Tracking Innerscope Research, Mar. 2007.

Egner, Tobias; Emilie Strawson, and John H. Gruzelier, "EEG Signature and Phenomenology of Alpha/theta Neurofeedback Training Versus Mock Feedback." *Applied Psychophysiology and Biofeedback*. vol. 27, No. 4. Dec. 2002.

Clarke, Adam R. et al., EEG Analysis of Children with Attention-Deficit/Hyperactivity Disorder and Comorbid Reading Disabilities, *Journal of Learning Disabilities*, vol. 35, No. 3, (May-Jun. 2002), pp. 276-285.

Carter, R., "Mapping the Mind" 1998 p. 182 University of California Press, Berkeley.

Harmony et al. (2004) Specific EEG frequencies signal general common cognitive processes as well as specific tasks processes in man. *Int. Journal of Psychophysiology* 53(3): 207-16.

Klimesch, W., Schimke, H., Schwaiger, J. (1994) Episodic and semantic memory: an analysis in the EEG theta and alpha band. *Electroencephalography Clinical Neurophysiology*.

Mizuhara, H., Wang LQ, Kobayashi, K., Yamaguchi, Y., (2004) A long range cortical network emerging with theta oscillation in mental task. *Neuroreport* 15(8): 1233-1238.

Seldon, G (1981) "Machines that Read Minds." *Science Digest*, October.

Willis, M. & Hodson, V.; *Discover Your Child's Learning Style: Children Learn in Unique Ways-Here's the Key to Every Child's Learning Success*, Prime Publishing, Roseville, CA.

Wise, A (1996) *The High Performance Mind, Mastering Brainwaves for Insight, Healing and Creativity*. G.P. Putnam's Son, New York. pp. 13-15; 20-22; 143-156.

Wise, A (1996) *The High Performance Mind, Mastering Brainwaves for Insight, Healing and Creativity*. G.P. Putnam's Son, New York. pp. 156-158; 165-170; 186-187, 189-192.

El-Bab, M. (2001) *Cognitive event related potentials during a learning task*. Doctoral Dissertation, Faculty of Medicine, University of Southampton, UK.

Gevins et al. (1997) High resolution EEG mapping of cortical activation related to a working memory, *Cereb Cortex*. 7: 374-385.

Hughes, J.R. & John, E.R. (1999) *Conventional and Quantitative Electroencephalography in Psychiatry*. *Journal of Neuropsychiatry and Clinical Neurosciences*. vol. 11(2): 190-208.

Decision of Rejection, English Language, issued by the State Intellectual Property Office of the P.R. China, in connection with Chinese application No. 201210063607.5, on Nov. 19, 2013, 10 pages.

Decision of Rejection, Chinese Language, issued by the State Intellectual Property Office of the P.R. China, in connection with Chinese application No. 201210063607.5, on Nov. 19, 2013, 6 pages.

Final Office Action, issued by the United States Patent and Trademark Office in connection with U.S. Appl. No. 13/553,515 on Jan. 9, 2014, 13 pages.

European office action, issued by the European Patent Office in connection with European patent application No. 07 852 430.3, on Feb. 6, 2013, 5 pages.

Final Decision of Rejection, English Language, issued by the Japanese Intellectual Property Office in connection with Japanese application No. 2009-552656, on Jan. 21, 2013, 3 pages.

Notice of Reason for Rejection, English Language, issued by the Japanese Intellectual Property Office in connection with Japanese application No. 2009-552660, on Mar. 13, 2013, 3 pages.

Notification of the Fourth Office Action, English Language, issued by the State Intellectual Property Office of the P.R. China, in connection with Chinese application No. 2006-80031159.3, on Oct. 18, 2012, 5 pages.

Advisory Action, issued by the United States Patent and Trademark Office in connection with U.S. Appl. No. 11/804,555, on Mar. 6, 2013, 3 pages.

Notice of Panel Decision from Pre-Appeal Brief Review, issued by the United States Patent and Trademark Office in connection with U.S. Appl. No. 11/804,555, on Mar. 25, 2013, 2 pages.

Notice for Reasons for Rejection, English Language, issued by the Intellectual Property Office of Japan, in connection with Japanese application No. 2009-552661, on Apr. 24, 2013, 2 pages.

Decision of Rejection, English Language, issued by the State Intellectual Property Office of the P.R. China, in connection with Chinese application No. 200780052879.2, on May 29, 2013, 11 pages.

Decision of Rejection, Chinese Language, issued by the State Intellectual Property Office of the P.R. China, in connection with Chinese application No. 200780052879.2, on May 29, 2013, 7 pages.

Final Office Action, issued by the United States Patent and Trademark Office in connection with U.S. Appl. No. 11/835,634 on Jun. 20, 2013, 23 pages.

First Office Action and Search Report, with English Language Version, issued by the State Intellectual Property Office of the Peoples' Republic of China, in connection with Chinese Patent Application No. 201210244954.8, on Jan. 2, 2014, 25 pages.

Notification of Reasons(s) for Rejection, issued by the Japanese Intellectual Property Office in connection with Japanese Patent Application No. 2012-152836, Jan. 14, 2014, 5 pages.

Notice of Allowance and Fee(s) Due, issued by the United States Patent and Trademark Office in connection with U.S. Appl. No. 11/845,993, on Feb. 19, 2014, 10 pages.

(56)

**References Cited**

## OTHER PUBLICATIONS

European Office Action, issued by the European Patent Office in connection with European Patent Application 07 852 430.3, on Feb. 3, 2014, 3 pages.

Office Action, issued by the United States Patent and Trademark Office in connection with U.S. Appl. No. 11/835,634, issued on Feb. 26, 2013, 24 pages.

Interrogative Statement, English Language, issued by the Intellectual Property Office of Japan, in connection with Japanese application No. 2009-552656, on Oct. 25, 2013, 4 pages.

European Office Action, issued by the European Patent Office in connection with European Patent Application No. 07796518.4, on Sep. 13, 2013, 7 pages.

European Office Action, issued by the European Patent Office in connection with European Patent Application No. 07838838.6, on Oct. 23, 2013, 4 pages.

Office Action, issued by the United States Patent and Trademark Office in connection with U.S. Appl. No. 13/553,515 on Jul. 17, 2013, 12 pages.

Notice of Allowance and Fee(s) Due, issued by the United States Patent and Trademark Office in connection with U.S. Appl. No. 11/804,555, on Mar. 3, 2014, 7 pages.

Notification of Reasons(s) for Rejection, issued by the Japanese Intellectual Property Office in connection with Japanese Patent Application No. 2009-552660 Jan. 21, 2014, 4 pages.

Notification of Grant of Patent Right for Invention, issued by the State Intellectual Property Office of the P.R. China, in connection with Chinese Patent Application No. 200780052869.9, on Aug. 31, 2012, 1 page.

Notification of the Third Office Action, issued by the State Intellectual Property Office of the P.R. China, in connection with Chinese Patent Application No. 200780052868.4, on Aug. 9, 2012, 7 pages.

Notification of the Second Office Action, issued by the State Intellectual Property Office of the P.R. China, in connection with Chinese Patent Application No. 200780052879.2, on May 4, 2012, 11 pages.

Notification of the Third Office Action, issued by the State Intellectual Property Office of the P.R. China, in connection with Chinese Patent Application No. 200680031159.3, on Mar. 28, 2012, 6 pages.

Notification of the Second Office Action, issued by the State Intellectual Property Office of the P.R. China, in connection with Chinese Patent Application No. 200680031159.3, on Oct. 19, 2011, 8 pages.

Notification of the Third Office Action, issued by the State Intellectual Property Office of the P.R. China, in connection with Chinese Patent Application No. 200780052879.2, on Dec. 31, 2012, 10 pages.

European Office Action, issued by the European Patent Office in connection with European Patent Application 07 838 838.6, on Sep. 5, 2012, 5 pages.

Supplemental European Search Report, issued by the European Patent Office in connection with European Patent Application No. 07796518.4, on Jul. 11, 2012, 8 pages.

European Office Action, issued by the European Patent Office in connection with European Patent Application No. 07 810 808.1, on Dec. 1, 2011, 6 pages.

Supplemental European Search Report, issued by the European Patent Office in connection with European Patent Application No. 06824810.3, on Nov. 22, 2011, 14 pages.

European Office Action, issued by the European Patent Office in connection with European Patent Application No. 07 852 430.3, on Mar. 6, 2012, 5 pages.

Supplemental European Search Report, issued by the European Patent Office in connection with European Patent Application No. 07811241.4, on Feb. 14, 2012, 6 pages.

European Office Action, issued by the European Patent Office in connection with European Patent Application No. 07 838 838.6, on Sep. 23, 2011, 4 pages.

Supplemental European Search Report, issued by the European Patent Office in connection with European Patent Application No. 06824810.3, on Nov. 3, 2011, 13 pages.

Supplemental European Search Report, issued by the European Patent Office in connection with European Patent Application No. 07796518.4, on Jul. 30, 2012, 9 pages.

Notification of Reason(s) for Rejection, issued by the Japanese Intellectual Property Office in connection with Japanese Patent Application No. 2009-552658, on Apr. 19, 2012, 2 pages.

Notification of Reason(s) for Rejection, issued by the Japanese Intellectual Property Office in connection with Japanese Patent Application No. 2009-552657, on May 2, 2012, 5 pages.

Notification of Reason(s) for Rejection, issued by the Japanese Intellectual Property Office in connection with Japanese Patent Application No. 2009-552656, on Mar. 30, 2012, 3 pages.

Notification of Reasons(s) for Rejection, issued by the Japanese Intellectual Property Office in connection with Japanese Patent Application No. 2008-529085, Nov. 29, 2011, 2 pages.

Notification of Reasons(s) for Rejection, issued by the Japanese Intellectual Property Office in connection with Japanese Patent Application No. 2009-552661, Nov. 13, 2012, 3 pages.

Notification of Reasons(s) for Rejection, issued by the Japanese Intellectual Property Office in connection with Japanese Patent Application No. 2009-552659, Nov. 16, 2012, 4 pages.

Notification of Reasons(s) for Rejection, issued by the Japanese Intellectual Property Office in connection with Japanese Patent Application No. 2009-552660, Nov. 16, 2012, 3 pages.

Notice of Allowance and Fee(s) Due, issued by the United States Patent and Trademark Office in connection with U.S. Appl. No. 11/804,517, on Mar. 21, 2012, 8 pages.

Final Rejection, issued by the United States Patent and Trademark Office in connection with U.S. Appl. No. 11/804,517, on Sep. 1, 2011, 11 pages.

Office Action, issued by the United States Patent and Trademark Office in connection with U.S. Appl. No. 11/804,517, on Feb. 3, 2011, 15 pages.

Final Rejection, issued by the United States Patent and Trademark Office in connection with U.S. Appl. No. 11/804,517, on Jun. 23, 2010, 14 pages.

Office Action, issued by the United States Patent and Trademark Office in connection with U.S. Appl. No. 11/804,517, on Sep. 17, 2009, 15 pages.

Office Action, issued by the United States Patent and Trademark Office in connection with U.S. Appl. No. 11/804,555, on Mar. 15, 2012, 15 pages.

Final Rejection, issued by the United States Patent and Trademark Office in connection with U.S. Appl. No. 11/804,555, on Oct. 9, 2012, 11 pages.

Final Rejection, issued by the United States Patent and Trademark Office in connection with U.S. Appl. No. 11/804,555, on Jul. 21, 2010, 14 pages.

Office Action, issued by the United States Patent and Trademark Office in connection with U.S. Appl. No. 11/804,555, on Oct. 1, 2009, 17 pages.

Office Action, issued by the United States Patent and Trademark Office in connection with U.S. Appl. No. 11/779,814, on Feb. 13, 2012, 19 pages.

Final Rejection, issued by the United States Patent and Trademark Office in connection with U.S. Appl. No. 11/779,814, on Jun. 28, 2012, 18 pages.

Final Rejection, issued by the United States Patent and Trademark Office in connection with U.S. Appl. No. 11/779,814, on Jun. 18, 2010, 24 pages.

Office Action, issued by the United States Patent and Trademark Office in connection with U.S. Appl. No. 11/779,814, on Oct. 5, 2009, 24 pages.

Final Rejection, issued by the United States Patent and Trademark Office in connection with U.S. Appl. No. 11/845,993, on Apr. 24, 2012, 8 pages.

Advisory Action, issued by the United States Patent and Trademark Office in connection with U.S. Appl. No. 11/845,993, on Jul. 20, 2012, 4 pages.

Office Action, issued by the United States Patent and Trademark Office in connection with U.S. Appl. No. 11/845,993, Aug. 4, 2011, 12 pages.

(56)

## References Cited

## OTHER PUBLICATIONS

- Final Rejection, issued by the United States Patent and Trademark Office in connection with U.S. Appl. No. 11/835,634, on Apr. 25, 2012, 23 pages.
- Office Action, issued by the United States Patent and Trademark Office in connection with U.S. Appl. No. 11/835,634, on Sep. 1, 2011, 16 pages.
- Final Rejection, issued by the United States Patent and Trademark Office in connection with U.S. Appl. No. 12/206,676, on Mar. 6, 2012, 9 pages.
- Office Action, issued by the United States Patent and Trademark Office in connection with U.S. Appl. No. 12/206,676, on May 10, 2011, 9 pages.
- Final Rejection, issued by the United States Patent and Trademark Office in connection with U.S. Appl. No. 12/206,702, on Jun. 3, 2010, 8 pages.
- Office Action, issued by the United States Patent and Trademark Office in connection with U.S. Appl. No. 12/206,702, on May 28, 2009, 8 pages.
- Final Rejection, issued by the United States Patent and Trademark Office in connection with U.S. Appl. No. 11/681,265, on Apr. 10, 2012, 18 pages.
- Office Action, issued by the United States Patent and Trademark Office in connection with U.S. Appl. No. 11/681,265, on Jun. 21, 2011, 15 pages.
- Restriction and/or Election Requirement, issued by the United States Patent and Trademark Office in connection with U.S. Appl. No. 11/846,068, on Feb. 21, 2012, 6 pages.
- Office Action, issued by the United States Patent and Trademark Office in connection with U.S. Appl. No. 11/846,068, on Apr. 27, 2012, 9 pages.
- Notice of Allowance and Fee(s) Due, issued by the United States Patent and Trademark Office in connection with U.S. Appl. No. 11/846,068, on Dec. 26, 2012, 9 pages.
- Office Action, issued by the United States Patent and Trademark Office in connection with U.S. Appl. No. 12/835,714, on Jan. 22, 2013, 34 pages.
- Adamic et al., "The political blogosphere and the 2004 U.S. election: Divided they blog," Proceedings WWW-2005 2nd Annual Workshop on the Weblogging Ecosystem, 2005, Chiba, Japan, 16 pages.
- Adar et al., "Implicit structure and the dynamics of blogspace," Proceedings WWW-2004 Workshop on the Weblogging Ecosystem, 2004, New York, NY, 8 pages.
- Aliod et al., "A Real World Implementation of Answer Extraction," Department of Computer Science, University of Zurich, Winterthurerstr. 190, CH-8057 Zurich, Switzerland, 6 pages.
- Bishop, Mike, "ARROW Question/Answering Systems," Language Computer Corporation, 1999, 3 pages.
- Bizrate, archived version of www.bizrate.com, Jan. 1999, 22 pages.
- Blum, "Empirical Support for Winnow and Weighted-Majority Algorithms: Results on a Calendar Scheduling Domain," in Machine Learning, vol. 26, Kluwer Academic Publishers, Boston, USA, 1997, 19 pages.
- Bournellis, Cynthia, "Tracking the hits on Web Sites," Communications International: vol. 22, Issue 9, London, Sep. 1995, 3 pages.
- Chaum et al., "A Secure and Privacy-Protecting Protocol for Transmitting Personal Information Between Organizations," A.M. Odlyzko (Ed.): Advances in Cryptology, CRYPTO '86, LNCS 263, 1987, 51 pages.
- Chaum, David L., "Untraceable Electronic Mail, Return Addresses, and Digital Pseudonyms," Communication of the ACM, vol. 24, No. 2, 1981, 5 pages.
- Cohen, William W., "Data Integration using similarity joins and a word-based information representation language," ACM Transactions on Information Systems, vol. 18, No. 3, Jul. 2000, 34 pages.
- Cohn et al., "Active Learning with Statistical Models," Journal of Artificial Intelligence Research 4, AI Access Foundation and Morgan Kaufmann Publishers, USA, 1996, 17 pages.
- Dagan et al., "Mistake-Driven Learning in Text Categorization," in EMNLP '97, 2<sup>nd</sup> Conference on Empirical Methods in Natural Language Processing, 1997, 9 pages.
- Delahaye Group, "Delahaye Group to Offer Nets Bench: High Level Web-Site Qualitative Analysis and Reporting; NetBench Builds on Systems provided by I/PRO and Internet Media Services," 1995 Business Wire, Inc., May 31, 1995, 3 pages.
- Dialogic, www.dialogic.com as archived on May 12, 2000, 34 pages.
- Dillon et al., "Marketing research in a Marketing Environment," Times Mirror/Mosby College, USA, 1987, 5 pages.
- Ewatch, eWatch's archived web site retrieved from [URL: http://web.archive.org/web/19980522190526/www.ewatch.com] on Sep. 8, 2004, archived May 22, 1998, 50 pages.
- Egner et al., "EEG Signature and Phenomenology of Alpha/theta Neurofeedback Training Versus Mock Feedback," Applied Psychophysiology and Biofeedback, vol. 27, No. 4, Dec. 2002, 10 pages.
- Farber, Dave, "IP: eWatch and Cybersleuth," retrieved from [URL: http://www.interesting-people.org/archives/interesting-people/200006/msg00090.html] Jun. 29, 2000, 4 pages.
- Freund et al., "Selective Sampling Using the Query by Committee Algorithm," Machine Learning 28 Kluwer Academic Publishers, The Netherlands, 1997, 36 pages.
- Glance et al., "Analyzing online discussion for marketing intelligence," Proceedings WWW-2005 2nd Annual Workshop on the Weblogging Ecosystem, Chiba, Japan, 2005, 2 pages.
- Glance et al., "Deriving marketing intelligence from online discussion," 11th ACM SIGKDD International Conference on Knowledge Discovery and Data Mining, Chicago, IL, Aug. 21-24, 2005, 10 pages.
- Grefenstette et al., "Validating the Coverage of Lexical Resources for Affect Analysis and Automatically Classifying New Words along Semantic Axes," Chapter X, Mar. 3, 2004, 16 pages.
- Harabagiu, Sanda M., "An Intelligent System for Question Answering," University of Southern California; Modlovan, Dan, Southern Methodist University, 1996, 5 pages.
- Harabagiu, Sanda M., "Experiments with Open-Domain Textual Question Answering," Department of Computer Science and Engineering at Southern Methodist University, 2000, 7 pages.
- Harabagiu, Sanda M., "Mining Textual Answers with Knowledge-Based Indicators," Department of Computer Science and Engineering at Southern Methodist University, 2000, 5 pages.
- Housley et al., "Internet X.509 Public Key Infrastructure Certificate and CRL Profile," Network Working Group Request for Comments: 2459, Jan. 1999, 121 pages.
- Joachims, Thorsten, "Text Categorization with Support Vector Machines: Learning with Many Relevant Features," in Machine Learning: ECML-98, Tenth European Conference on Machine Learning, 1998, 7 pages.
- Kahn et al., "Categorizing Web Documents using Competitive Learning: An ingredient of a Personal Adaptive Agent," IEEE 1997, 4 pages.
- Katz, Boris, "From Sentence Processing to Information Access on the World Wide Web," MIT Artificial Intelligence Laboratory, Feb. 27, 1997, 20 pages.
- Kleppner, "Advertising Procedure," 6th edition, 1977, Prentice-Hall, Inc., Englewood Cliffs, NJ, p. 492, 3 pages.
- Kotler, "Marketing Management," PrenticeHall International Inc., Upper Saddle River, NJ, 1997, 10 pages.
- Klimesch, "EEG alpha and theta oscillations reflect cognitive and memory performance: a review and analysis," Brain Research Reviews, vol. 29, 1999, 27 pages.
- Lenz et al., "Question answering with Textual CBR," Department of Computer Science, Humboldt University Berlin, D-10099 Berlin, 1998, 12 pages.
- Littlestone, Nick, "Learning Quickly When Irrelevant Attributes Abound: A New Linear-threshold Algorithm," in Machine Learning, vol. 2, Kluwer Academic Publishers, Boston, MA, 1988, 34 pages.
- Marlow, "Audience, structure and authority in the weblog community," International Communication Association Conference, MIT Media Laboratory, New Orleans, LA 2004, 9 pages.

(56)

## References Cited

## OTHER PUBLICATIONS

McCallum et al., "Text Classification by Bootstrapping with the Keywords, EM and Shrinkage," Just Research and Carnegie Mellon University, Pittsburgh, PA, circa 1999, 7 pages.

McLachlan et al., "The EM Algorithm and Extensions," John Wiley & Sons, Inc., New York, NY, 1997, 301 pages.

Moldovan et al., "LASSO: A Tool for Surfing the Answer Net," Department of Computer Science and Engineering at Southern Methodist University, 1999, 9 pages.

Nakashima et al., "Information Filtering for the Newspaper," IEEE 1997, 4 pages.

Nanno et al., "Automatic collection and monitoring of Japanese Weblogs," Proceedings WWW-2004 Workshop on the weblogging Ecosystem, 2004, New York, NY, 7 pages.

Netcurrent, NetCurrent's web site, <http://web.archive.org/web/20000622024845/www.netcurrents.com>, retrieved on Jan. 17, 2005, archived on Jun. 22, 2000 and Sep. 18, 2000, 17 pages.

Pang et al., "Thumbs up? Sentiment Classification using Machine Learning Techniques," in Proceedings of EMNLP 2002, 8 pages.

Reguly, "Caveat Emptor Rules on the Internet," The Globe and Mail (Canada): Report on Business Column, Apr. 10, 1999, 2 pages.

Reinartz, "Customer Lifetime Value Analysis: An Integrated Empirical Framework for Measurement and Explanation," dissertation: Apr. 1999, 68 pages.

Schmidt et al., "Frontal brain electrical activity (EEG) distinguishes valence and intensity of musical emotions," *Cognition and Emotion*, vol. 15 (4), Psychology Press Ltd, 2001, 14 pages.

Sammler, "Music and emotion: Electrophysiological correlates of the processing of pleasant and unpleasant music," *Psychophysiology*, vol. 44, Blackwell Publishing Inc., 2007, 12 pages.

Soderland et al., "Customer Satisfaction and Links to Customer Profitability: An Empirical Examination of the Association Between Attitudes and Behavior," SSE/EFI Working Paper Series in Business Administration, Jan. 1999, 22 pages.

Thomas, "International Marketing," International Textbook Company, Scranton, PA 1971, 3 pages.

Trigaux, Robert, "Cyberwar Erupts Over Free Speech Across Florida, Nation," Knight-Ridder Tribune Business News, May 29, 2000, 4 pages.

Tull et al., "Marketing Research Measurement and Method," MacMillan Publishing Company, New York, NY, 1984, 9 pages.

Voorhees, Ellen M., "The TREC-8 Question Answering Track Report," National Institute of Standards and Technology, 1999, 6 pages.

Wiebe et al., "Identifying Collocations for Recognizing Opinions," in proceedings of ACL/EACL '01 Workshop on Collocation, Toulouse, France, Apr. 9, 2001, 9 pages.

Word of Mouth Research Case Study, "The Trans Fat Issue, Analysis of online consumer conversation to understand how the Oreo lawsuit impacted word-of-mouth on trans fats," Aug. 16, 2004, 35 pages.

Yang, "An Evaluation of Statistical Approaches to Text Categorization," *Information Retrieval* 1 (1/2) Apr. 10, 1999, 12 pages.

Zagat, [www.zagat.com](http://www.zagat.com), archived on Apr. 29, 1999, 33 pages.

Zagat, [www.zagat.com](http://www.zagat.com), archived version of p. 34, Feb. 1999, 1 page.

Notification of the Second Office Action, issued by the State Intellectual Property Office of the P.R. China, in connection with Chinese Patent Application No. 201210063607.5, on Aug. 28, 2014, 9 pages.

Office Action, issued by the United States Patent and Trademark Office in connection with U.S. Appl. No. 12/206,676, on Oct. 2, 2014, 13 pages.

Notification of Reason(s) for Rejection, issued by the Japanese Intellectual Property Office in connection with Japanese Patent Application No. JP2009552656, on Aug. 27, 2014, 13 pages.

Coan, J. A., et al., "Voluntary Facial Expression and Hemispheric Asymmetry Over the Frontal Cortex," *Psychophysiology*, 38 (Nov. 2001), pp. 912-925, 14 pages.

European Office Action, issued by the European Patent Office in connection with European Patent Application No. 07838838.6 on Mar. 12, 2014, 3 pages.

Office Action, issued by the United States Patent and Trademark Office in connection with U.S. Appl. No. 13/553,515, on Jun. 20, 2014, 12 pages.

Notification of the Second Office Action, issued by the State Intellectual Property Office of the P.R. China, in connection with Chinese Patent Application No. 201210244954.8 on Jul. 10, 2014, 26 pages.

Summons to Attend Oral Proceedings Pursuant to Rule 115(1) EPC, issued by the European Patent Office in connection with European Patent Application No. 07796518A on Sep. 4, 2014, 7 pages.

Office Action, issued by the United States Patent and Trademark Office in connection with U.S. Appl. No. 11/681,265 on Dec. 2, 2014, 18 pages.

Notification of Grant of Patent Right for Invention, issued by the State Intellectual Property Office of the P.R. China, in connection with Chinese Patent Application No. 201210244954.8 on Dec. 16, 2014, 6 pages.

Notification of Reexamination, issued by the State Intellectual Property Office of the P.R. China, in connection with Chinese Patent Application No. 200780052879.2 on Feb. 4, 2015, 21 pages.

European Office Action, issued by the European Patent Office in connection with European Patent Application 07838838.6, on Feb. 23, 2015, 3 pages.

European Decision and Minutes, issued by the European Patent Office in connection with European Patent Application 07796518.4 on Mar. 12 and 13, 2015, 65 pages.

Notification on Grant of Patent Right for Invention, issued by the State Intellectual Property Office of the P.R. China, in connection with Chinese Patent Application No. 201210063607.5, on Mar. 31, 2015, 4 pages.

Final Rejection, issued by the United States Patent and Trademark Office in connection with U.S. Appl. No. 12/206,676, on Jun. 19, 2015, 16 pages.

Notification of Reexamination, issued by the State Intellectual Property Office of the P.R. China, in connection with Chinese Patent Application No. 200780052879.2, on Jul. 1, 2015, 12 pages.

Notice of Allowance and Fee(s) Due, issued by the United States Patent and Trademark Office in connection with U.S. Appl. No. 11/681,265, Jul. 17, 2015, 8 pages.

\* cited by examiner

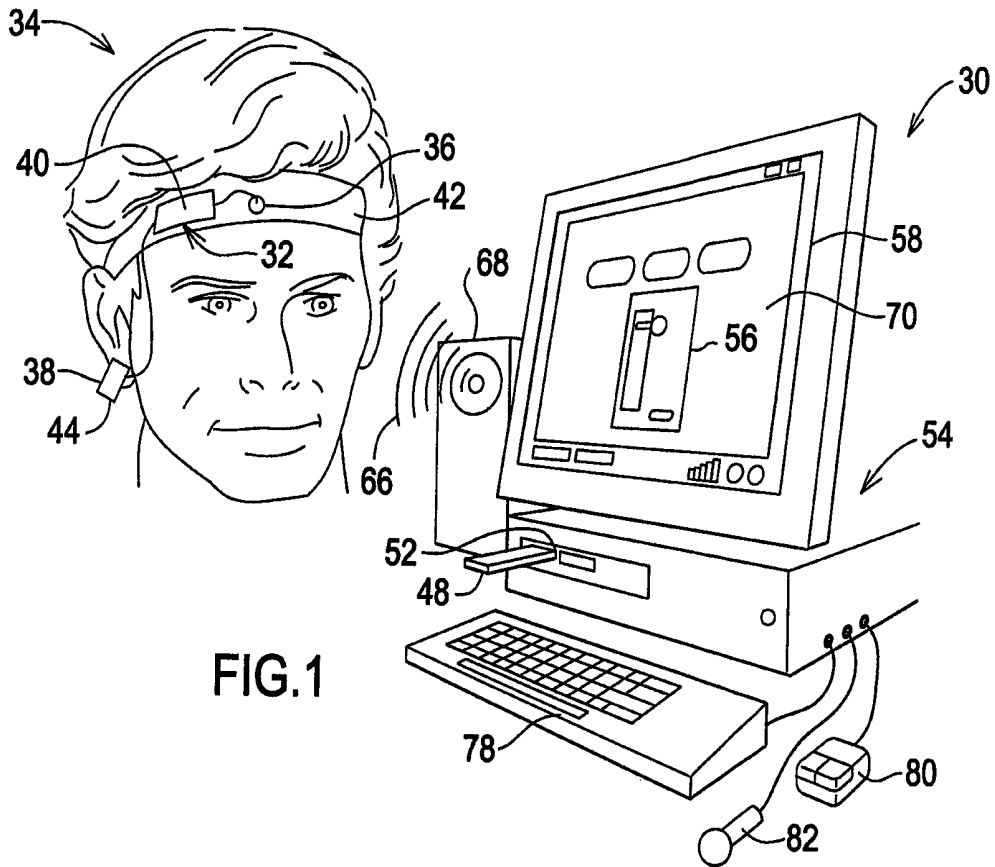

FIG. 1

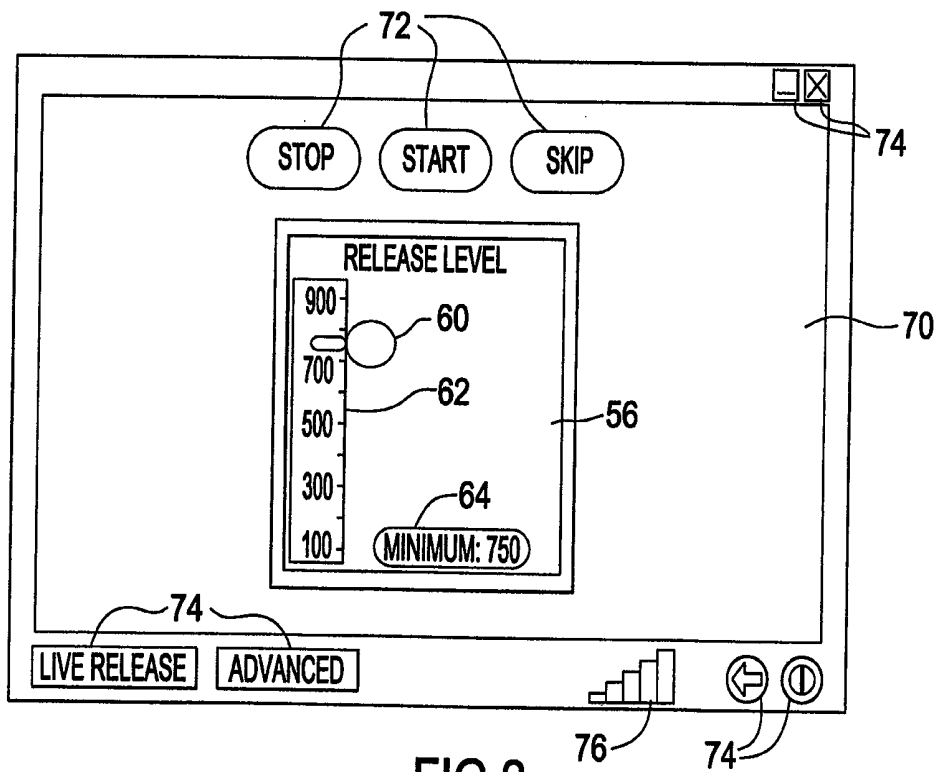

FIG. 2

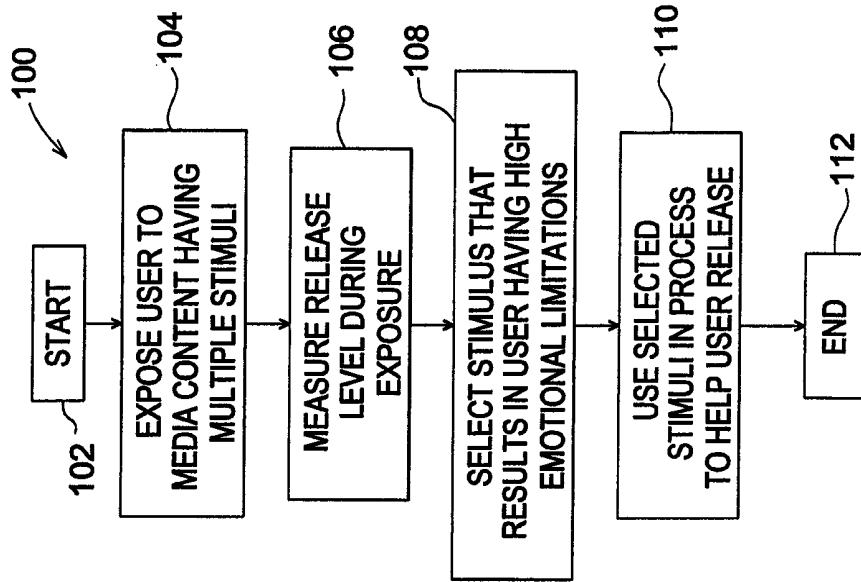

FIG.4

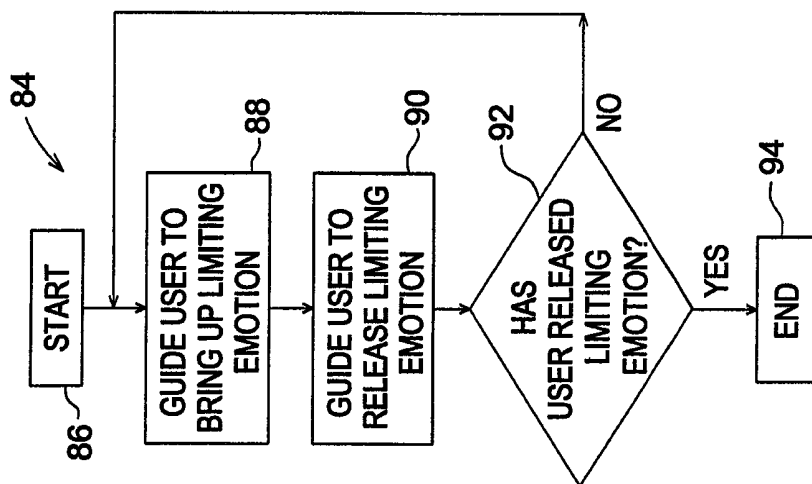

FIG.3

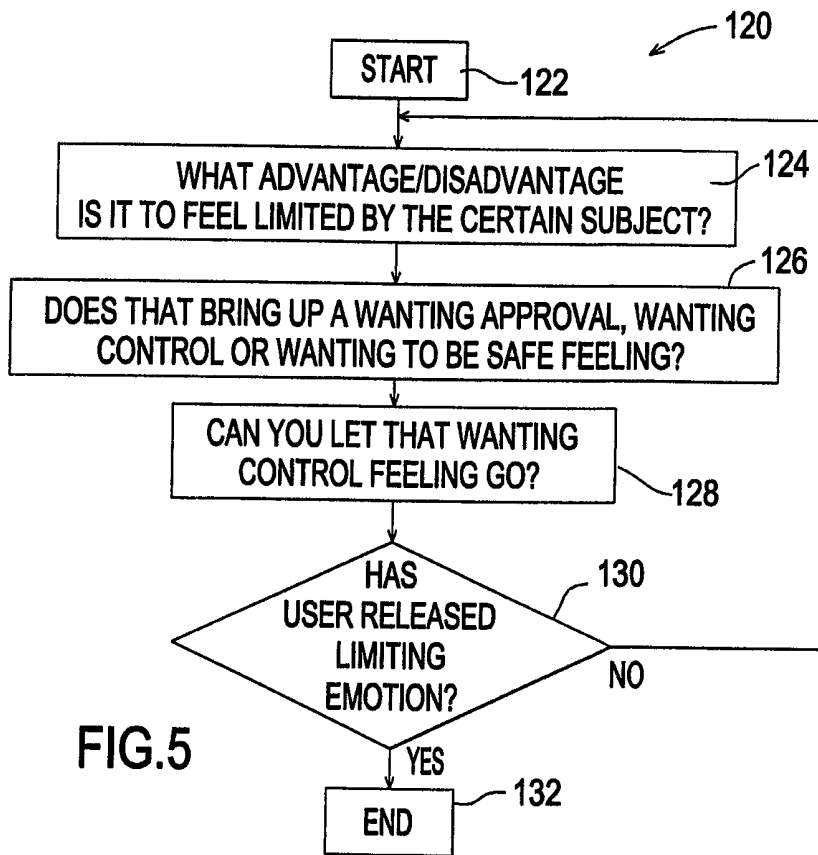

FIG.5

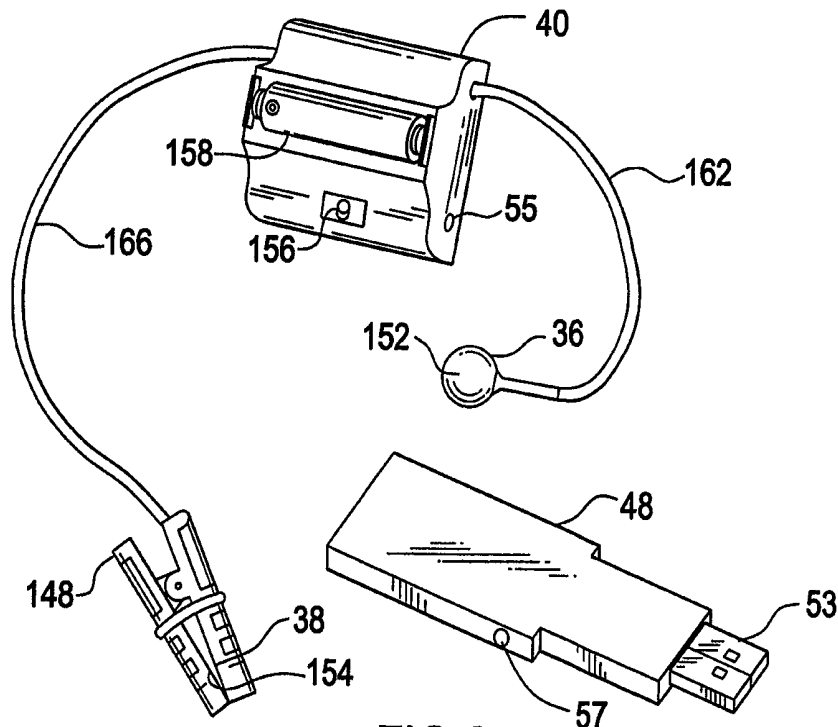

FIG.6

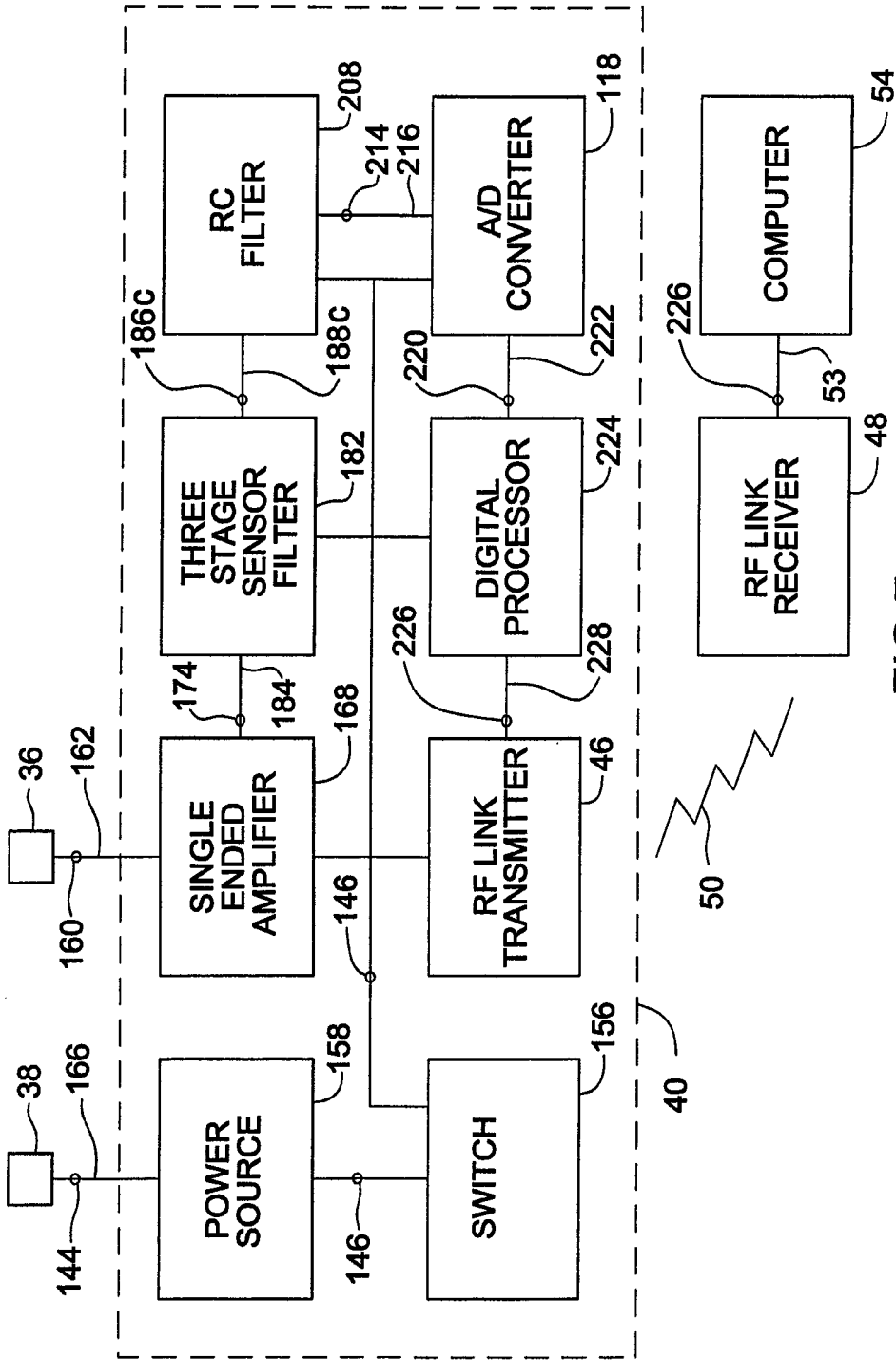

FIG. 7

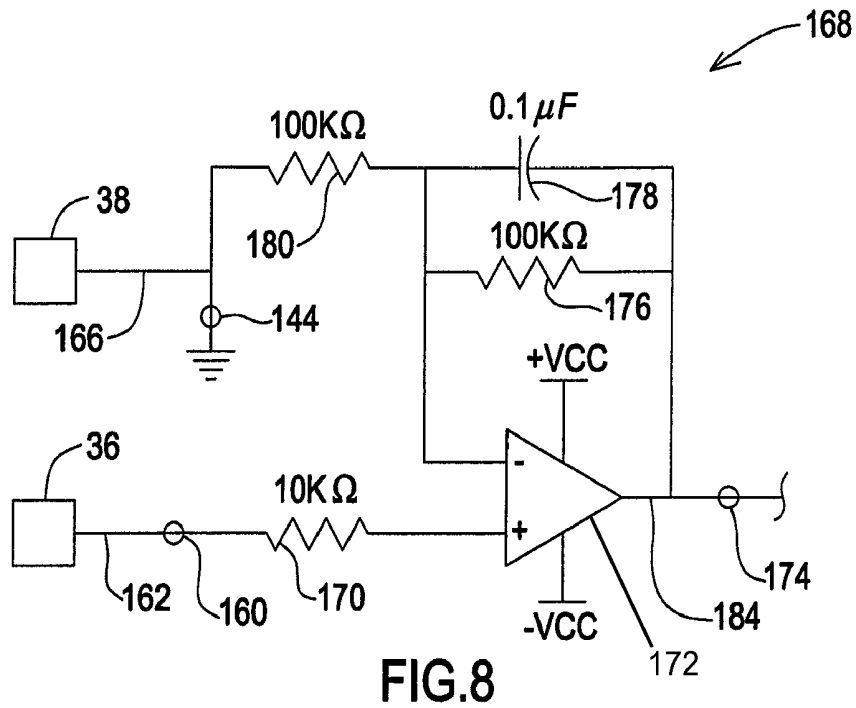

FIG.8

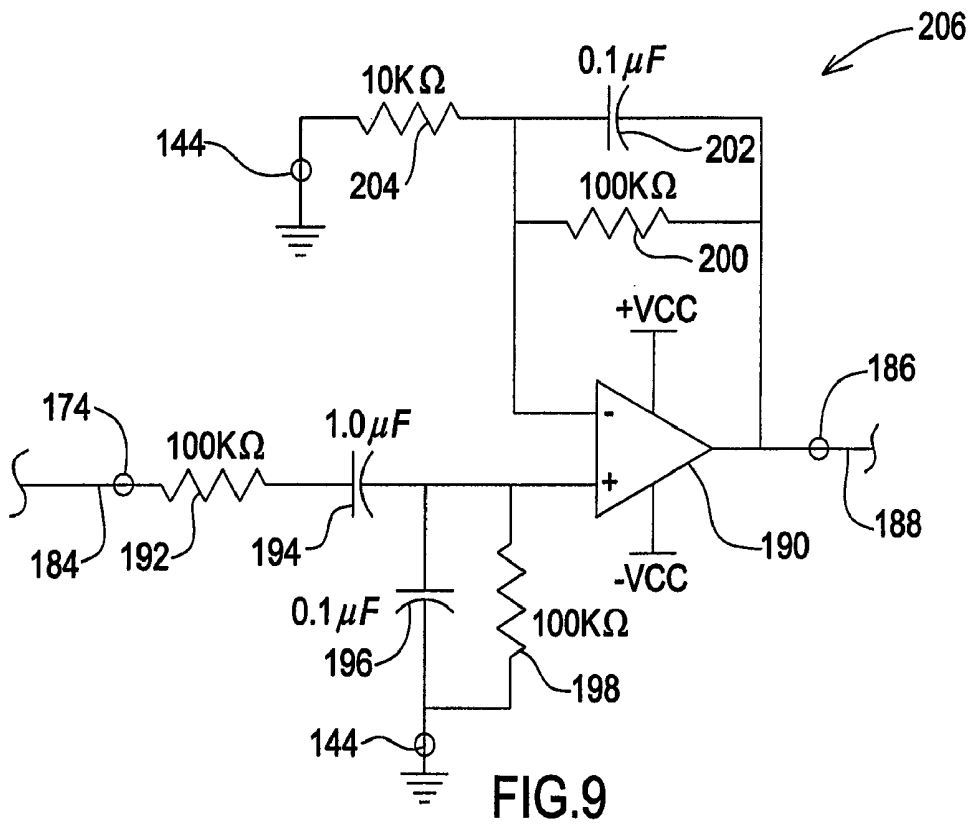

FIG.9

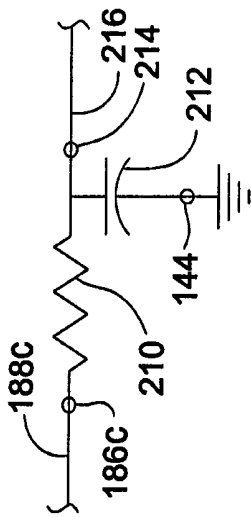

FIG. 10

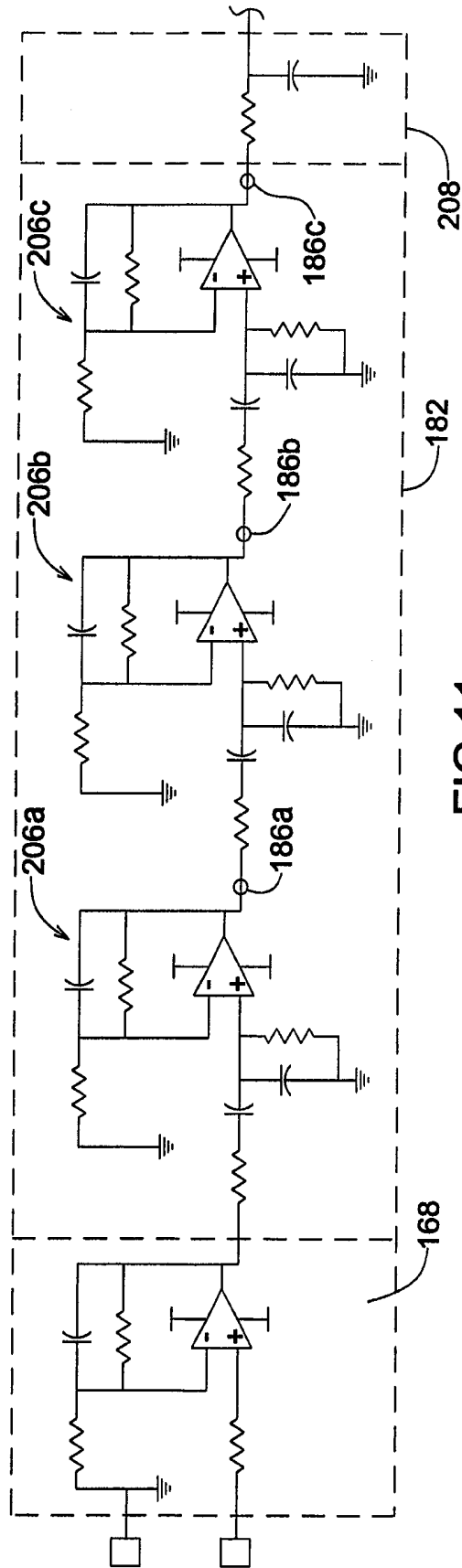

FIG. 11

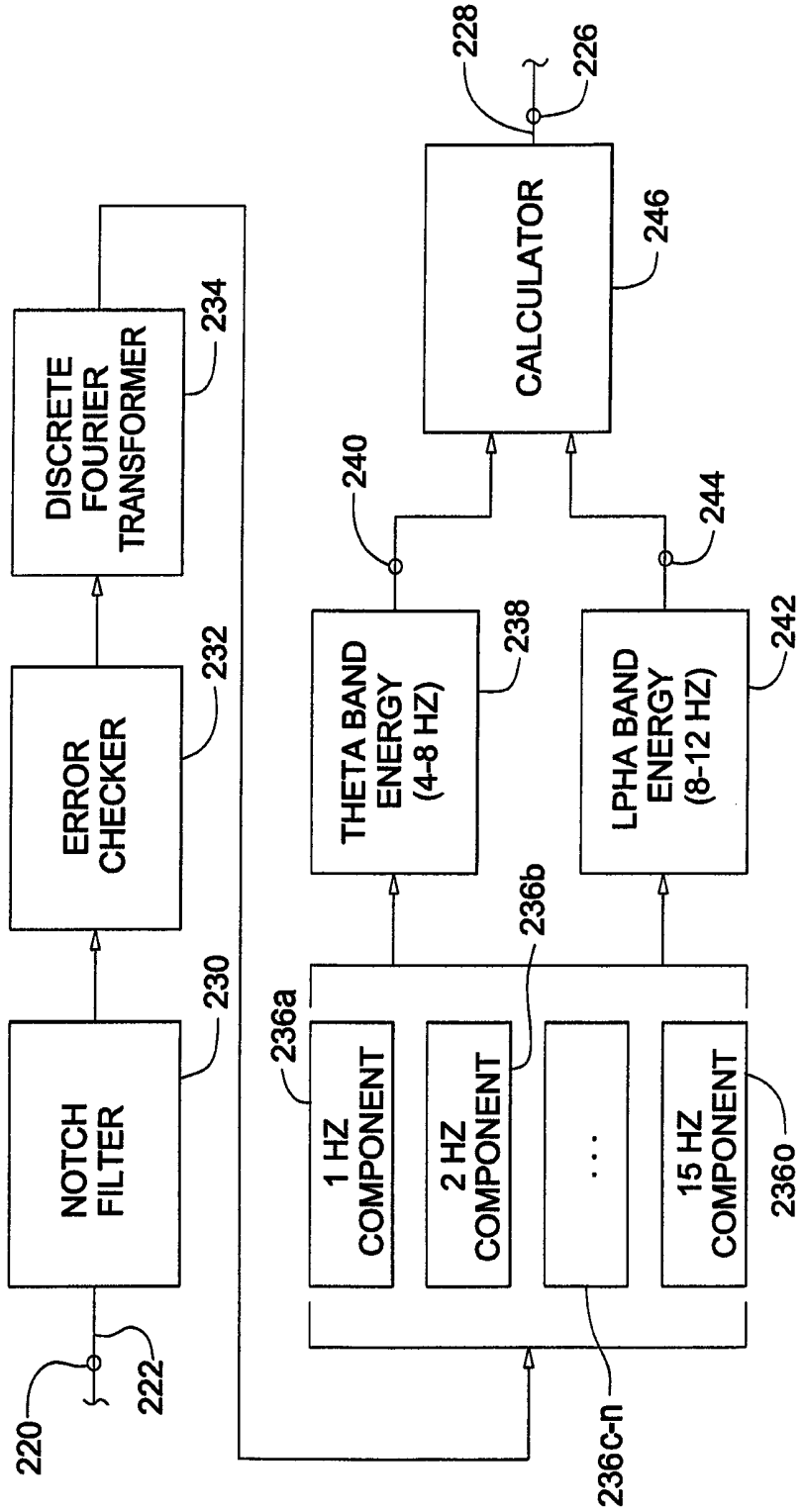

FIG. 12

## DEVICE AND METHOD FOR SENSING ELECTRICAL ACTIVITY IN TISSUE

### RELATED APPLICATIONS

The present application claims the benefit of U.S. Provisional Application Ser. No. 60/713,899, filed on Sep. 2, 2005, which is incorporated herein by reference. In addition, the present application arises from a continuation of U.S. patent application Ser. No. 11/500,679, filed Aug. 8, 2006, which claims the benefit of U.S. Provisional Application Ser. No. 60/706,580, filed on Aug. 9, 2005, both of which are hereby incorporated by reference.

### BACKGROUND

Devices used for sensing electrical activity in tissue have many uses in modern society. In particular modern electroencephalograms (EEGs) are used for measuring electrical activity in the brains of people for anesthesia monitoring, attention deficit disorder treatment, epilepsy prediction, and sleep monitoring, among other uses. Unfortunately, the complexity and cost of prior modern EEGs typically limits their use to clinics or other facilities where the device can be used on numerous people under the expert attention of a trained medical professional. Using the EEG on numerous people in a clinical setting helps to distribute the cost of the machine to the people which use it. EEGs can cost several thousand dollars.

Trained personnel are used for setting up and operating EEGs because of the complexities involved. Setting up prior EEGs involves preparing the skin of the person for connection of electrodes. The skin is typically prepared by shaving the hair from the area, sanding the skin to remove the outer surface and applying a conductive gel or liquid to the skin before attaching the electrode to the skin. Such extensive skin preparation is needed because contact resistance between the electrode and the skin must be reduced in order for prior EEGs to work properly. Contact resistance in these prior EEGs typically needs to be 20 k ohms or less.

Typical prior EEGs are subject to errors caused by electrical and magnetic noise from the environment surrounding the person. Errors are also caused by slight variations in internal components of the EEG and other sources, such as movement of the person during the operation of the EEG. Environmental noise can be caused by 60 Hz power in electrical wiring and lights in the area where the EEG is used, and other sources. Even the friction of any object moving through the air can cause noise from static electricity. Most or all prior EEGs have two electrodes are connected to the person's head and wires which are run from each of the electrodes to the EEG machine. The routing of the wires and the positions of the noise causing elements in the environment can cause significant errors in the measurements done by the EEG.

Measuring the electrical activity in the brain is difficult because the electrical signal being measured is many times smaller than the noise in the system. In many instances, the noise is on the order of a few volts or a few tens of volts while the electrical signal being measured is only in the microvolt range. This gives a signal-to-noise ratio of  $10^6$ .

Prior EEGs have used very precise differential amplifiers, such as instrumentation amplifiers, to measure the electrical signal. The amplifier is referenced to a common reference such as the leg of the user. Each of the two wires from the two electrodes on the person's head are connected to the inputs of the differential amplifier. The output of the differential amplifier is a voltage relative to the reference which is proportional

to the difference in voltage between the two electrodes times a constant. The measurement in this case is very sensitive because the differential amplifier is finding a small difference, the brain signal, between two signals which are  $10^6$  times as large. These are reasons why small variations in components, the routing of the wires and other factors cause significant errors in the measurement and why prior EEGs are expensive and hard to use.

Another problem with the prior EEGs is that the 60 Hz noise is amplified at the first stage which saturates the signals before they are subtracted. In prior EEGs, designers go to great lengths to design systems that balance or shield the noise to avoid saturation. Systems which use the principle of subtracting two large numbers in measuring a small number are prone to these kinds of problems.

The foregoing examples of the related art and limitations related therewith are intended to be illustrative and not exclusive. Other limitations of the related art will become apparent to those of skill in the art upon reading of the specification and a study of the drawings.

### SUMMARY

The following embodiments and aspects thereof are described and illustrated in conjunction with systems, tools and methods which are meant to be exemplary and illustrative, not limiting in scope. In various embodiments, one or more of the above-described problems have been reduced or eliminated, while other embodiments are directed to other improvements.

A method is described for sensing electrical activity in tissue of a user. Electrical activity is detected from the tissue between a first point and a second point on skin of the user and a voltage signal is generated in response thereto which contains a signal of interest and undesired signals. The voltage signal is amplified to amplify the signal of interest and undesired signals without substantially amplifying the noise. The amplification results in an output signal.

Another method is disclosed for sensing electrical activity in tissue of a user in a noise environment that is subjected to electrical noise. A sensor electrode is connected to skin of the user at a first point. A reference electrode is connected to skin of the user at a second point which is in a spaced apart relationship to the first point to allow the sensor electrode to sense the electrical activity in the tissue at the first point relative to the second point. An amplifier is provided which is configured to amplify the electrical activity while substantially reducing the influence from the noise environment.

A sensor circuit is described for sensing electrical activity in tissue of a user and isolating and amplifying a signal of interest from the sensed electrical activity. The sensor circuit includes a sensor electrode for placing on skin of the user at a first point. A reference electrode for placing at a second point which is a distance away from the first point to allow the sensor electrode to sense the electrical activity and to produce a voltage signal relative to the second point which includes the signal of interest in response. An electronic module of the sensor circuit includes a power source with positive and negative source voltages and a source reference voltage which is electrically connected to the reference electrode. An amplifier is connected to receive power from the power source and to receive the voltage signal from the sensor electrode and the power source reference voltage. The amplifier produces an output signal which is proportional to the voltage signal relative to the power source reference voltage. A filter portion

receives the output signal from the amplifier and attenuates electrical activity unrelated to the signal of interest while passing the signal of interest.

In addition to the exemplary aspects and embodiments described above, further aspects and embodiments will become apparent by reference to the drawings and by study of the following descriptions.

#### BRIEF DESCRIPTION OF THE DRAWINGS

FIG. 1 is an illustration of a system which uses a sensor device which measures electrical activity to determine a present time emotional state of a user.

FIG. 2 is an illustration of a program which contains a display of a level of the present time emotional state of the user and has controls for media material used in guiding the user in relation to the present time emotional state of the user.

FIG. 3 is a diagram of one example in which the media material guides the user based on the present time emotional state of the user.

FIG. 4 is a diagram of another example in which the media material guides the user based on the present time emotional state of the user.

FIG. 5 is a diagram of yet another example in which the media material guides the user based on the present time emotional state of the user.

FIG. 6 is a perspective view of the sensor device shown in FIG. 1.

FIG. 7 is a block diagram of the sensor device and a computer shown in FIG. 1.

FIG. 8 is a circuit diagram of an amplifier used in the sensor device shown in FIG. 7.

FIG. 9 is a circuit diagram of a filter stage used in the sensor device shown in FIG. 7.

FIG. 10 is a circuit diagram of a resistor-capacitor RC filter used in the sensor device shown in FIG. 7.

FIG. 11 is a circuit diagram of the amplifier, three filter stages and the RC filter shown in FIGS. 8, 9 and 10.

FIG. 12 is a block diagram of a digital processor of the sensor device shown in FIG. 7.

#### DETAILED DESCRIPTION

A system 30 which incorporates the present discussion is shown in FIG. 1. Exemplary system 30 includes a sensor device 32 which is connected to a user 34 for sensing and isolating a signal of interest from electrical activity in the user's pre-frontal lobe. The signal of interest has a measurable characteristic of electrical activity, or signal of interest, which relates to a present time emotional state (PTES) of user 34. PTES relates to the emotional state of the user at a given time. For instance, if the user is thinking about something that causes the user emotional distress, then the PTES is different than when the user is thinking about something which has a calming affect on the emotions of the user. In another example, when the user feels a limiting emotion regarding thoughts, then the PTES is different than when the user feels a state of release regarding those thoughts. Because of the relationship between the signal of interest and PTES, system 30 is able to determine a level of PTES experienced by user 34 by measuring the electrical activity and isolating a signal of interest from other electrical activity in the user's brain.

In the present example, sensor device 32 includes a sensor electrode 36 which is positioned at a first point and a reference electrode 38 which is positioned at a second point. The first and second points are placed in a spaced apart relationship while remaining in close proximity to one another. The points

are preferably within about 8 inches of one another, and in one instance the points are about 4 inches apart. In the present example, sensor electrode 36 is positioned on the skin of the user's forehead and reference electrode 38 is connected to the user's ear. The reference electrode can also be attached to the user's forehead, which may include positioning the reference electrode over the ear of the user.

Sensor electrode 36 and reference electrode 38 are connected to an electronics module 40 of sensor device 32, which is positioned near the reference electrode 38 to that they are located substantially in the same noise environment. The electronics module 40 may be located at or above the temple of the user or in other locations where the electronics module 40 is in close proximity to the reference electrode 38. In the present example, a head band 42 or other mounting device holds sensor electrode 36 and electronics module 40 in place near the temple while a clip 44 holds reference electrode 38 to the user's ear. In one instance, the electronics module and reference electrode are positioned relative to one another such that they are capacitively coupled.

Sensor electrode 36 senses the electrical activity in the user's pre-frontal lobe and electronics module 40 isolates the signal of interest from the other electrical activity present and detected by the sensor electrode. Electronics module 40 includes a wireless transmitter 46, (FIG. 6), which transmits the signal of interest to a wireless receiver 48 over a wireless link 50. Wireless receiver 48, FIG. 1, receives the signal of interest from electronics module 40 and connects to a port 52 of a computer 54, or other device having a processor, with a port connector 53 to transfer the signal of interest from wireless receiver 48 to computer 54. Electronics module 40 includes an LED 55 (FIG. 6), and wireless receiver 48 includes an LED 57 which both illuminate when the wireless transmitter and the wireless receiver are powered.

In the present example, levels of PTES derived from the signal of interest are displayed in a meter 56, (FIGS. 1 and 2), on a computer screen 58 of computer 54. In this instance, computer 54, and screen 58 displaying meter 56 serve as an indicator. Levels of detail of meter 56 can be adjusted to suit the user. Viewing meter 56 allows user 34 to determine their level of PTES at any particular time in a manner which is objective. The objective feedback obtained from meter 56 is used for guiding the user to improve their PTES and to determine levels of PTES related to particular memories or thoughts which can be brought up in the mind of user 34 when the user is exposed to certain stimuli. Meter 56 includes an indicator 60 which moves vertically up and down a numbered bar 62 to indicated the level of the user's PTES. Meter 56 also includes a minimum level indicator 64 which indicates a minimum level of PTES achieved over a certain period of time or during a session in which user 34 is exposed to stimuli from media material 66. Meter 56 can also include the user's maximum, minimum and average levels of release during a session. Levels of PTES may also be audibly communicated to the user, and in this instance, the computer and speaker serve as the indicator. The levels can also be indicated to the user by printing them on paper.

In another instance, different release levels relating to reaction to the same media material can be stored over time on a memory device. These different release levels can be displayed next to one another to inform the user on his or her progress in releasing the negative emotions related to the media material.

In system 30, media material 66 is used to expose user 34 to stimuli designed to cause user 34 to bring up particular thoughts or emotions which are related to a high level of PTES in the user. In the present example, media material 66

includes audio material that is played through computer **54** over a speaker **68**. Media material **66** and meter **56** are integrated into a computer program **70** which runs on computer **54** and is displayed on computer screen **58**. Media material **66** is controlled using on-screen buttons **72**, in this instance. Computer program **70** also has other menu buttons **74** for manipulation of program functions and an indicator **76** which indicates connection strength of the wireless link **50**. Program **70** is typically stored in memory of computer **54**, this or another memory device can also contain a database for storing self-reported journals and self-observed progress.

In some instances, program **70** may require a response or other input from user **34**. In these and other circumstances, user **34** may interact with program **70** using any one or more suitable peripheral or input device, such as a keyboard **78**, mouse **80** and/or microphone **82**. For instance, mouse **80** may be used to select one of buttons **72** for controlling media material **66**.

Media material **66** allows user **34** to interact with computer **54** for self or assisted inquiry. Media material **66** can be audio, visual, audio and visual, and/or can include written material files or other types of files which are played on or presented by computer **54**. Media material **66** can be based on one or more processes, such as "The Release Technique" or others. In some instances, generic topics can be provided in the form of audio-video files presented in the form of pre-described exercises. These exercises can involve typical significant life issues or goals for most individuals, such as money, winning, relationships, and many other popular topics that allow the user to achieve a freedom state regarding these topics. The freedom state about the goal can be displayed when a very low level of PTES, (under some preset threshold) is achieved by the user regarding the goal. The release technique is used as an example in some instances; other processes may also be used with the technological approach described herein.

In one instance, media material **66** involving "The Release Technique" causes user **34** to bring up a limiting emotion or an emotion-laden experience type of PTES, which results in a disturbance in the nervous system of the user. The process then guides user **34** to normalize the nervous system or release the emotion while the user is focused on the perceived cause of the disturbance. When it is determined that the level of PTES, or release level in this instance, is below a preset threshold then the process is completed.

The signal of interest which relates to the release level PTES are brain waves or electrical activity in the pre-frontal lobe of the user's brain in the range of 4-12 Hz. These characteristic frequencies of electrical activity are in the Alpha and Theta bands. Alpha band activity is in the 8 to 12 Hz range and Theta band activity is in the 4 to 7 Hz range. A linear relationship between amplitudes of the Alpha and Theta bands is an indication of the release level. When user **34** is in a non-release state, the activity is predominantly in the Theta band and the Alpha band is diminished; and when user **34** is in a release state the activity is predominantly in the Alpha band and the energy in the Theta band is diminished.

When user **34** releases the emotion, totality of thoughts that remain in the subconscious mind is lowered in the brain as the disturbance is incrementally released from the mind. A high number of thoughts in the subconscious mind results in what is known as unhappiness or melancholy feelings, which are disturbances in the nervous system. A low number of thoughts in the subconscious mind results in what is known as happiness or joyful feelings, which results in a normalization or absence of disturbances in the nervous system.

An exemplary method **84** which makes use of one or more self or assisted inquiry processes is shown in FIG. **3**. Method

**84** begins at a start **86** from which the method moves to a step **88**. At step **88**, program **70** uses stimuli in media material **66** to guide user **34** to bring up thoughts or subjects which causes an emotional disturbance in the PTES such as a limiting emotion. In the present example, media material **66** involves questions or statements directed to user **34** through speaker **68**. In this and other instances, the computer can insert statements about goals or issue which were input by the user into the media material **66**. For example, user **34** may input a goal statement using keyboard **78** and the computer may generate a voice which inserts the goal statement into the media material. In another example, the user may input the goal statement using microphone **82** and the computer may insert the goal statement into the media material.

Method **84** then proceeds to step **90** where program **70** uses media material **66** to guide user **34** to release the limiting emotions while still focusing on the thought or subject which causes the limiting emotion. From step **90**, the program proceeds to step **92** where a determination is made as to whether user **34** has released the limiting emotions. This determination is made using the signal of interest from sensor device **32**. In the instance case, the level of release is indicated by the position of indicator **60** on bar **62** in meter **56**, as shown in FIG. **2**. If the meter indicates that user **34** has released the limiting emotions to an appropriate degree, such as below the preset threshold, then the determination at **92** is yes and method **84** proceeds to end at step **94**. If the determination at **92** is that user **34** has not release the limiting emotions to an appropriate degree, then the determination at **92** is no, and method **84** returns to step **88** to again guide the user to bring up the thought or subject causing the limiting emotion. Method **84** can be continued as long as needed for user **34** to release the limiting emotions and achieve the freedom state. Processes can also include clean up sessions in which the user is guided by the media material to release many typical limiting emotions to assist the user in achieving a low thought frequency releasing the limiting emotions.

By observing meter **56** while attempting to release the limiting emotions, user **34** is able to correlate feelings with the release of limiting emotions. Repeating this process reinforces the correlation so that the user learns what it feels like to release and is able to release effectively with or without the meter **56** by having an increased releasing skill. A loop feature allows the user to click on a button to enter a loop session in which the releasing part of an exercise is repeated continuously. The levels of the user's PTES are indicated to the user and the levels are automatically recorded during these loop sessions for later review. Loop sessions provide a fast way in which to guide a user to let go of limiting emotions surrounding particular thoughts related to particular subjects. The loop session does not require the user to do anything between repetitions which allows them to maintain the desirable state of low thought activity, or the release state. Loop sessions can be included in any process for guiding the user to improve their PTES.

Computer **54** is also able to record release levels over time to a memory device to enable user **34** to review the releasing progress achieved during a recorded session. Other sessions can be reviewed along side of more recent sessions to illustrate the progress of the user's releasing ability by recalling the sessions from the memory device.

System **30** is also used for helping user **34** to determine what particular thoughts or subjects affect the user's PTES. An example of this use is a method **100**, shown in FIG. **4**. Method **100** begins at start **102** from which the method proceeds to step **104**. At step **104**, user **34** is exposed to a session of media content **42** which contains multiple stimuli that are

presented to user 34 over time. Method 100 proceeds to step 106 where the levels of PTES of user 34 are determined during the session while the user is exposed to the multiple stimuli. Following step 106 method proceeds to step 108 where stimulus is selected from the media content 42 which resulted in negative affects on the PTES, such as high emotional limitations. Method 100 therefore identifies for the user areas which results in the negative affects on the PTES. Method 100 then proceeds to step 110 where the selected stimuli is used in a process to help the user release the negative emotions. Method 100 ends at step 112.

In one example, program 70 uses a method 120, FIG. 5, which includes a questioning pattern called "Advantages/Disadvantages." In this method, the media file asks user 34 several questions in sequence related to advantages/disadvantages of a "certain subject", which causes the user to experience negative emotions. Words or phrases of the "certain subject" can be entered into the computer by the user using one of the input devices, such as keyboard 78, mouse 80 and/or microphone 82 which allows the computer to insert the words or phrases into the questions. System 30 may also have goal documents that have the user's goal statements displayed along with the questioning patterns about the goal and release level data of the user regarding the goal. As an example, the user may have an issue which relates to control, such as a fear of being late for an airline flight. In this instance, the user would enter something like "fear of being late for a flight" as the "certain subject."

Series of questions related to advantages and disadvantage can be alternated until the state of release, or other PTES, is stabilized as low as possible, that is with the greatest amount of release. Method 120, shown in FIG. 5, starts at a start 122 from which it proceeds to step 124 where program 70 asks user 34 "What advantage/disadvantage is it to me to feel limited by the certain subject?" Program 70 then waits for feedback from the user through one of the input devices.

Program then proceeds to step 126 where program 70 asks user 34 "Does that bring up a wanting approval, wanting control or wanting to be safe feeling?" Program 70 waits for a response from user 34 from the input device and deciphers which one of the feelings the user responds with, such as "control feeling" for instance. Method 120 then proceeds to step 128 where program 70 questions the user based on the response given to step 128 by asking "Can you let that wanting control feeling go?" in this instance. At this point method 120 proceeds to step 130 where sensor device 32 determines the signal of interest to determine the release level of user 34. The release level is monitored and the media file stops playing when the release level has stabilized at its lowest point. At this time method 120 proceeds to step 132 and the session is complete. When the session is complete, user 34 will feel a sense of freedom regarding the certain subject. If some unwanted emotional residue is left, this same process can be repeated until complete freedom regarding the issue is realized by the user.

The above method is an example of "polarity releasing" in which an individual is guided to think about positives and negatives about a certain subject or particular issue, until the mind gives up on the negative emotions generated by the thoughts. There are other polarity releasing methods, such as "Likes/Dislikes" and other concepts and methods that help user's to achieve lower though frequency which may also be used along with a sensor device such as sensor device 32 for the purposes described herein.

Program 70 can store the history of responses to media on a memory device, and combine multiple iterations of responses to the same media in order to create a chart of

improvement for user 34. Plotting these responses on the same chart using varying colors and dimensional effects demonstrates to user 34 the various PTES reactions over time to the same media stimulus, demonstrating improvement.

Program 70 can store reaction to live content as well. Live content can consist of listening to a person or audio in the same physical location, or listening to audio streaming over a telecommunications medium like telephone or the Internet, or text communications. Program 70 can send the PTES data from point-to-point using a communication medium like the Internet. With live content flowing in one direction, and PTES data flowing in the other, the deliverer of live content has a powerful new ability to react and change the content immediately, depending on the PTES data reaction of the individual. This deliverer may be a person or a web server application with the ability to understand and react to changing PTES.

Program 70 can detect the version of the electronic module 40 latently, based on the type of data and number of bytes being sent. This information is used to turn on and off various features in the program 70, depending on the feature's availability in the electronic module 40.

With certain types of computers and when certain types of wireless links are used, an incompatibility between wireless receiver 48 and computer 54 may occur. This incompatibility between an open host controller interface (OHCI) of the computer 54 and a universal host controller interface (UHCI) chip in the wireless receiver 48 causes a failure of communication. Program 70 has an ability to detect the symptom of this specific incompatibility and report it to the user. The detection scheme looks for a single response to a ping 'P' from the wireless receiver 48, and all future responses to a ping are ignored. Program 70 then displays a modal warning to the user suggesting workarounds for the incompatibility.

Program 70 detects the disconnecting of wireless link 50 by continually checking for the arrival of new data. If new data stops coming in, it assumes a wireless link failure, and automatically pauses the media being played and recording of PTES data. On detection of new data coming into the computer 54, the program 70 automatically resumes the media and recording.

Program 70 can create exercises and set goals for specific PTES levels. For example, it asks the user to set a target level of PTES and continues indefinitely until the user has reached that goal. Program 70 can also store reactions during numerous other activities. These other activities include but are not limited to telephone conversations, meetings, chores, meditation, and organizing. In addition, program 70 can allow users to customize their sessions by selecting audio, title, and length of session.

Other computing devices, which can include processor based computing devices, (not shown) can be used with sensor device 32 to play media material 66 and display or otherwise indicate the PTES. These devices may be connected to the sensor device 32 utilizing an integrated wireless receiver rather than the separate wireless receiver 48 which plugs into the port of the computer. These devices are more portable than computer 54 which allows the user to monitor the level PTES throughout the day or night which allows the user to liberate the subconscious mind more rapidly. These computing devices can include a camera with an audio recorder for storing and transmitting data to the receiver to store incidents of reactivity on a memory device for review at a later time. These computing devices can also upload reactivity incidents, intensity of these incidents and/or audio-video recordings of these incidents into computer 54 where the Attach-

ment and Aversions process or other process can be used to permanently reduce or eliminate reactivity regarding these incidents.

One example of sensor device **32** is shown in FIGS. 6 and 7. Sensor device **32** includes sensor electrode **36**, reference electrode **38** and electronics module **40**. The electronics module **40** amplifies the signal of interest by 1,000 to 100,000 times while at the same time insuring that 60 Hz noise is not amplified at any point. Electronics module **40** isolates the signal of interest from undesired electrical activity.

Sensor device **32** in the present example also includes wireless receiver **48** which receives the signal of interest from the electronics module over wireless link **50** and communicates the signal of interest to computer **54**. In the present example, wireless link **50** uses radiofrequency energy; however other wireless technologies may also be used, such as infrared. Using a wireless connection eliminates the need for wires to be connected between the sensor device **32** and computer **54** which electrically isolates sensor device **32** from computer **54**.

Reference electrode **38** is connected to a clip **148** which is used for attaching reference electrode **38** to an ear **150** of user **34**, in the present example. Sensor electrode **36** includes a snap or other spring loaded device for attaching sensor electrode **36** to headband **42**. Headband **42** also includes a pocket for housing electronics module **40** at a position at the user's temple. Headband **42** is one example of an elastic band which is used for holding the sensor electrode and/or the electronics module **40**, another types of elastic bands which provide the same function could also be used, including having the elastic band form a portion of a hat.

Other types of mounting devices, in addition to the elastic bands, can also be used for holding the sensor electrode against the skin of the user. A holding force holding the sensor electrode against the skin of the user can be in the range of 1 to 4 oz. The holding force can be, for instance, 1.5 oz.

In another example of a mounting device involves a frame that is similar to an eyeglass frame, which holds the sensor electrode against the skin of the user. The frame can also be used for supporting electronics module **40**. The frame is worn by user **34** in a way which is supported by the ears and bridge of the nose of the user, where the sensor electrode **36** contacts the skin of the user.

Sensor electrode **36** and reference electrode **38** include conductive surface **152** and **154**, respectively, that are used for placing in contact with the skin of the user at points where the measurements are to be made. In the present example, the conductive surfaces are composed of a non-reactive material, such as copper, gold, conductive rubber or conductive plastic. Conductive surface **152** of sensor electrode **36** may have a surface area of approximately  $\frac{1}{2}$  square inch. The conductive surfaces **152** are used to directly contact the skin of the user without having to specially prepare the skin and without having to use a substance to reduce a contact resistance found between the skin and the conductive surfaces.

Sensor device **32** works with contact resistances as high as 500,000 ohms which allows the device to work with conductive surfaces in direct contact with skin that is not specially prepared. In contrast, special skin preparation and conductive gels or other substances are used with prior EEG electrodes to reduce the contact resistances to around 20,000 ohms or less. One consequence of dealing with higher contact resistance is that noise may be coupled into the measurement. The noise comes from lights and other equipment connected to 60 Hz power, and also from friction of any object moving through the air which creates static electricity. The amplitude of the noise is proportional to the distance between the electronics

module **40** and the reference electrode **38**. In the present example, by placing the electronics module over the temple area, right above the ear and connecting the reference electrode to the ear, the sensor device **32** does not pick up the noise, or is substantially unaffected by the noise. By positioning the electronics module in the same physical space with the reference electrode and capacitively coupling the electronics module with the reference electrode ensures that a local reference potential **144** in the electronics module and the ear are practically identical in potential. Reference electrode **38** is electrically connected to local reference potential **144** used in a power source **158** for the sensor device **32**.

Power source **158** provides power **146** to electronic components in the module over power conductors. Power source **158** provides the sensor device **32** with reference potential **144** at 0 volts as well as positive and negative source voltages,  $-VCC$  and  $+VCC$ . Power source **158** makes use of a charge pump for generating the source voltages at a level which is suitable for the electronics module.

Power source is connected to the other components in the module **40** though a switch **156**. Power source **158** can include a timer circuit which causes electronics module **40** to be powered for a certain time before power is disconnected. This feature conserves power for instances where user **34** accidentally leaves the power to electronics module **40** turned on. The power **146** is referenced locally to measurements and does not have any reference connection to an external ground system since sensor circuit **32** uses wireless link **50**.

Sensor electrode **36** is placed in contact with the skin of the user at a point where the electrical activity in the brain is to be sensed or measured. Reference electrode **38** is placed in contact with the skin at a point a small distance away from the point where the sensor electrode is placed. In the present example, this distance is 4 inches, although the distance may be as much as about 8 inches. Longer lengths may add noise to the system since the amplitude of the noise is proportional to the distance between the electronics module and the reference electrode. Electronics module **40** is placed in close proximity to the reference electrode **38**. This causes the electronics module **40** to be in the same of electrical and magnetic environment is the reference electrode **38** and electronics module **40** is connected capacitively and through mutual inductance to reference electrode **38**. Reference electrode **38** and amplifier **168** are coupled together into the noise environment, and sensor electrode **36** measures the signal of interest a short distance away from the reference electrode to reduce or eliminate the influence of noise on sensor device **32**. Reference electrode **38** is connected to the 0V in the power source **158** with a conductor **166**.

Sensor electrode **36** senses electrical activity in the user's brain and generates a voltage signal **160** related thereto which is the potential of the electrical activity at the point where the sensor electrode **36** contacts the user's skin relative to the local reference potential **144**. Voltage signal **160** is communicated from the electrode **36** to electronics module **40** over conductor **162**. Conductors **162** and **166** are connected to electrodes **36** and **38** in such a way that there is no solder on conductive surfaces **152** and **154**. Conductor **162** is as short as practical, and in the present example is approximately 3 inches long. When sensor device **32** is used, conductor **162** is held a distance away from user **34** so that conductor **162** does not couple signals to or from user **34**. In the present example, conductor **162** is held at a distance of approximately  $\frac{1}{2}$ " from user **34**. No other wires, optical fibers or other types of extensions extend from the electronics module **40**, other than the

conductors **162** and **166** extending between module **40** and electrodes **36** and **38**, since these types of structure tend to pick up electronic noise.

The electronics module **40** measures or determines electrical activity, which includes the signal of interest and other electrical activity unrelated to the signal of interest which is undesired. Electronics module **40** uses a single ended amplifier **168**, (FIGS. **7** and **8**), which is closely coupled to noise in the environment of the measurement with the reference electrode **38**. The single ended amplifier **168** provides a gain of 2 for frequencies up to 12 Hz, which includes electrical activity in the Alpha and Theta bands, and a gain of less than 1 for frequencies 60 Hz and above, including harmonics of 60 Hz.

Amplifier **168**, FIGS. **8** and **11**, receives the voltage signal **160** from electrode **36** and power **146** from power source **158**. Single ended amplifier **168** generates an output signal **174** which is proportional to voltage signal **160**. Output signal **174** contains the signal of interest. In the present example, voltage signal **160** is supplied on conductor **162** to a resistor **170** which is connected to non-inverting input of high impedance, low power op amp **172**. Output signal **174** is used as feedback to the inverting input of op amp **172** through resistor **176** and capacitor **178** which are connected in parallel. The inverting input of op amp **172** is also connected to reference voltage **144** through a resistor **180**.

Amplifier **168** is connected to a three-stage sensor filter **182** with an output conductor **184** which carries output signal **174**. The electrical activity or voltage signal **160** is amplified by each of the stages **168** and **182** while undesired signals, such as those 60 Hz and above, are attenuated by each of the stages. Three-stage sensor filter has three stages **206a**, **206b** and **206c** each having the same design to provide a bandpass filter function which allows signals between 1.2 and 12 Hz to pass with a gain of 5 while attenuating signal lower and higher than these frequencies. The bandpass filter function allows signals in the Alpha and Theta bands to pass while attenuating noise such as 60 Hz and harmonics of the 60 Hz. The three stage sensor filter **182** removes offsets in the signal that are due to biases and offsets in the parts. Each of the three stages is connected to source voltage **146** and reference voltage **144**. Each of the three stages generates an output signal **186a**, **186b** and **186c** on an output conductor **188a**, **186b** and **188c**, respectively.

In the first stage **206a**, FIGS. **9** and **11**, of three-stage sensor filter **182**, output signal **174** is supplied to a non-inverting input of a first stage op-amp **190a** through a resistor **192a** and capacitor **194a**. A capacitor **196a** and another resistor **198a** are connected between the non-inverting input and reference voltage **144**. Feedback of the output signal **186a** from the first stage is connected to the inverting input of op amp **190a** through a resistor **200a** and a capacitor **202a** which are connected in parallel. The inverting input of op amp **190a** is also connected to reference voltage **144** through resistor **204a**.

Second and third stages **206b** and **206c**, respectively, are arranged in series with first stage **206a**. First stage output signal **186a** is supplied to second stage **206b** through resistor **192b** and capacitor **194b** to the non-inverting input of op-amp **190b**. Second stage output signal **186b** is supplied to third stage **206c** through resistor **192c** and capacitor **194c**. Resistor **198b** and capacitor **196b** are connected between the non-inverting input of op-amp **190b** and reference potential **144**, and resistor **198c** and capacitor **196c** are connected between the non-inverting input of op-amp **190c** and reference potential **144**. Feedback from output conductor **188b** to the inverting input of op-amp **190b** is through resistor **200b** and capacitor **202b** and the inverting input of op-amp **190b** is also connected to reference potential **144** with resistor **204b**. Feed-

back from output conductor **188c** to the inverting input of op-amp **190c** is through resistor **200c** and capacitor **202c** and the inverting input of op-amp **190c** is also connected to reference potential **144** with resistor **204c**.

Three stage sensor filter **182** is connected to an RC filter **208**, FIGS. **10** and **11**, with the output conductor **188c** which carries the output signal **186c** from third stage **206c** of three stage sensor filter **182**, FIG. **7**. RC filter **208** includes a resistor **210** which is connected in series to an output conductor **216**, and a capacitor **212** which connects between reference potential **144** and output conductor **216**. RC filter serves as a low pass filter to further filter out frequencies above 12 Hz. RC filter **208** produces a filter signal **214** on output conductor **216**. RC filter **208** is connected to an analog to digital (A/D) converter **218**, FIG. **7**.

A/D converter **218** converts the analog filter signal **214** from the RC filter to a digital signal **220** by sampling the analog filter signal **214** at a sample rate that is a multiple of 60 Hz. In the present example the sample rate is 9600 samples per second. Digital signal **220** is carried to a digital processor **224** on an output conductor **222**.

Digital processor **224**, FIGS. **7** and **12** provides additional gain, removal of 60 Hz noise, and attenuation of high frequency data. Digital processor **224** may be implemented in software operating on a computing device. Digital processor **224** includes a notch filter **230**, FIG. **12** which sums 160 data points of digital signal **220** at a time to produce a 60 Hz data stream that is free from any information at 60 Hz. Following notch filter **230** is an error checker **232**. Error checker **232**, removes data points that are out of range from the 60 Hz data stream. These out of range data points are either erroneous data or they are caused by some external source other than brain activity.

After error checker **232**, digital processor **224** transforms the data stream using a discrete Fourier transformer **234**. While prior EEG systems use band pass filters to select out the Alpha and Theta frequencies, among others, these filters are limited to processing and selecting out continuous periodic functions. By using a Fourier transform, digital processor **224** is able to identify randomly spaced events. Each event has energy in all frequencies, but shorter events will have more energy in higher frequencies and longer events will have more energy in lower frequencies. By looking at the difference between the energy in Alpha and Theta frequencies, the system is able to identify the predominance of longer or shorter events. The difference is then scaled by the total energy in the bands. This causes the output to be based on the type of energy and removes anything tied to amount of energy.

The Fourier transformer **234** creates a spectrum signal that separates the energy into bins **236a** to **236o** which each have a different width of frequency. In one example, the spectrum signal has 30 samples and separates the energy spectrum into 2 Hz wide bins; in another example, the spectrum signal has 60 samples and separates the bins into 1 Hz wide bins. Bins **236** are added to create energy signals in certain bands. In the present example, bins **236** between 4 and 8 Hz are passed to a summer **238** which sums these bins to create a Theta band energy signal **240**; and bins between 8 and 12 Hz are passed to a summer **242** which sums these bins to create an Alpha band energy signal **244**.

In the present example, the Alpha and Theta band energy signals **240** and **244** are passed to a calculator **246** which calculates  $(\text{Theta}-\text{Alpha})/(\text{Theta}+\text{Alpha})$  and produces an output signal **226** on a conductor **228** as a result.

Output signal **226**, FIG. **7**, is passed to wireless transmitter **46** which transmits the output signal **226** to wireless receiver **48** over wireless link **50**. In the present example, output signal

226 is the signal of interest which is passed to computer 54 through port 52 and which is used by the computer to produce the PTES for display in meter 56.

Computer 54 may provide additional processing of output signal 226 in some instances. In the example using the Release Technique, the computer 54 manipulates output signal 226 to determine relative amounts of Alpha and Theta band signals in the output signal to determine levels of release experienced by user 34.

A sensor device utilizing the above described principles and feature can be used for determining electrical activity in other tissue of the user in addition to the brain tissue just described, such as electrical activity in muscle and heart tissue. In these instances, the sensor electrode is positioned on the skin at the point where the electrical activity is to be measured and the reference electrode and electronics module are positioned nearby with the reference electrode attached to a point near the sensor electrode. The electronics module, in these instances, includes amplification and filtering to isolate the frequencies of the muscle or heart electrical activity while filtering out other frequencies.

While a number of exemplary aspects and embodiments have been discussed above, those of skill in the art will recognize certain modifications, permutations, additions and sub-combinations thereof. It is therefore intended that the following appended claims and claims hereafter introduced are interpreted to include all such modifications, permutations, additions and sub-combinations as are within their true spirit and scope.

What is claimed is:

1. A method comprising:

detecting electrical activity from a tissue of a user via a sensor of a headpiece worn by the user, the sensor including:

a sensor electrode to contact a first point on skin of the user;

a reference electrode to contact a second point on the skin of the user, the contact between the reference electrode and the skin of the user to cause a contact resistance between a surface of the reference electrode and the skin of the user; and

an electronics module positioned proximate the reference electrode to reduce noise, a local reference potential in the electronics module and a potential of the second point on the skin being approximately equal to allow the surface of the reference electrode to be in direct contact with the skin of the user at the second point without having to prepare the skin or use a material that decreases the contact resistance, the electrical activity represented by a voltage signal including a signal of interest, undesired signals, and noise, the electronics module including:

an amplifier to (1) amplify the signal of interest and the undesired signals within a first frequency range while (2) filtering the noise occurring in a second frequency range, which includes frequencies higher than the first frequency range, prior to transmitting the amplified signal of interest and undesired signals to one or more filters; and

transforming, with a processor and a Fourier transform, the signal of interest to form an output signal.

2. A method as defined in claim 1, wherein the amplifier is to amplify the signal of interest and the undesired signals by using the local reference potential of the electronics module, and connecting the second point directly to the local reference potential.

3. A method as defined in claim 1, wherein the amplifier is to amplify the signal of interest at the electronics module by using the local reference potential and source voltages, and positioning the electronics module in a region of the headpiece adjacent to the second point so as to electrically couple the local reference potential and source voltages to the second point.

4. A method as defined in claim 1, wherein the amplifier is to amplify the signal of interest at the electronics module and detecting the electrical activity includes using conductors extending from the electronics module to the sensor and reference electrodes at the first and second points, and electrically isolating the electronics module by keeping the electronics module free of wires, optical fibers or other extensions other than the conductors extending to the sensor and reference electrodes.

5. A method as defined in claim 1 further including filtering an output signal of the amplifier with the electronics module to attenuate the undesired signals and to isolate the signal of interest from the undesired signals.

6. A method as defined in claim 5 further including communicating the signal of interest to a computing device.

7. A method as defined in claim 6, wherein the computing device is to display information relating to the signal of interest.

8. A method as defined in claim 6, wherein the computing device is to produce audio related to the signal of interest.

9. A method as defined in claim 5, wherein the signal of interest relates to electrical activity in brain tissue of the user.

10. A method as defined in claim 5, wherein the signal of interest relates to electrical activity in muscle tissue of the user.

11. A method as defined in claim 5, wherein the signal of interest relates to electrical activity in heart tissue of the user.

12. A method as defined in claim 5, wherein filtering the output signal of the amplifier attenuates undesired signals below about 4 Hz and above about 12 Hz.

13. A method as defined in claim 5, wherein the signal of interest includes Alpha and Theta band brain waves.

14. A method as defined in claim 1, wherein the second point is on an ear of the user.

15. A method as defined in claim 1, wherein the second point is approximately 4 inches from the first point.

16. A method as defined in claim 1, wherein the second point is on a forehead of the user.

17. A method as defined in claim 1, wherein the second point is within approximately 8 inches of the first point.

18. A method as defined in claim 1, wherein the undesired signals include noise signals caused by environmental noise.

19. A method as defined in claim 1, wherein a contact resistance of the sensor electrode and the reference electrode can be as high as 500,000 ohms.

20. A method as defined in claim 1 further including positioning the electronics module with the processor at a temple of the user and positioning the reference electrode at an ear of the user.

21. A method as defined in claim 20, wherein the processor and reference electrode are to be positioned at the right temple and ear of the user.

22. A method as defined in claim 1 further including: isolating the signal of interest from the undesired signals by filtering the output signal.

23. A method as defined in claim 1, wherein the processor is to convert the output signal from analog to digital, wherein the output signal is converted at a rate that is a multiple of 60 Hz.

15

24. A method as defined in claim 1 further including testing the output signal for data that is inconsistent with EEG data, and removing the inconsistent data from the output signal.

25. A method as defined in claim 1 further including transforming the output signal using the Fourier Transform to determine an energy spectrum signal based on an energy spectrum of the output signal.

26. A method as defined in claim 25 further including dividing the energy spectrum signal into groups of 60 samples and separating the energy spectrum into 1 Hz wide bins.

27. A method as defined in claim 25 further including dividing the energy spectrum signal into groups of 30 samples and separating the energy spectrum into 2 Hz wide bins.

28. A method as defined in claim 25 further including dividing the energy spectrum signal into groups of samples and separating the energy spectrum into bins which each represent energy in a certain range of frequencies, and summing energy in bins that have about 4-8 Hz to create a Theta band energy signal.

29. A method as defined in claim 28 further including summing energy in bins that have about 8-12 Hz to create an Alpha band energy signal.

30. A method as defined in claim 29 further including generating the signal of interest by determining a ratio of the Alpha and Theta band energy signals.

31. A method comprising:

detecting electrical activity from a tissue of a user via a sensor of a headpiece worn by the user, the sensor including an electronics module, a sensor electrode and a reference electrode, the sensor electrode is to contact a first point on skin of the user and the reference electrode is to contact a second point on the skin of the user, the contact between the reference electrode and the skin of the user to cause a contact resistance between a surface of the reference electrode and the skin of the user, the electronics module being positioned proximate the reference electrode to reduce noise, a local reference potential in the electronics module and a potential of the second point on the skin being approximately equal to allow the surface of the reference electrode to be in direct contact with the skin of the user at the second point without having to prepare the skin or use a material that decreases the contact resistance, the electrical activity represented by a voltage signal including a signal of interest and undesired signals;

transforming, with a processor, the voltage signal using a Fourier Transform to determine an energy spectrum signal based on an energy spectrum of the voltage signal;

16

dividing the energy spectrum signal into groups of samples and separating the energy spectrum into bins that represent energy in a certain range of frequencies;

summing energy in bins that have about 4-8 Hz to create a Theta band energy signal;

summing energy in bins that have about 8-12 Hz to create an Alpha band energy signal; and

generating the signal of interest by determining a ratio of the Alpha and Theta band energy signals, wherein the ratio includes (Theta signal-Alpha signal)/(Theta signal+Alpha signal).

32. A method as defined in claim 1 further including: sampling the output signal for a certain number of samples in each  $\frac{1}{60}$ <sup>th</sup> of a second; and

summing the samples from each  $\frac{1}{60}$ <sup>th</sup> of a second to create a processed signal with no 60 Hz interference.

33. A method as defined in claim 1, wherein the sensor electrode is electrically coupled to a first input of the amplifier, the reference electrode is electrically coupled to a second input of the amplifier, and an output of the amplifier is electrically coupled to the second input of the amplifier via a low pass filter.

34. A method as defined in claim 33, wherein the reference electrode is in circuit with the local reference potential in the electronics module.

35. A method as defined in claim 34, wherein a signal path of the sensor electrode to the first input is electrically isolated from a signal path of the reference electrode to the second input.

36. A method as defined in claim 1, wherein the amplifier is a low pass operational amplifier.

37. A method as defined in claim 36, wherein the noise includes signals above about 60 Hz.

38. A method as defined in claim 1, wherein the electronics module further includes a filter electrically coupled to an output of the amplifier, wherein the filter is to isolate the signal of interest and further attenuate the noise.

39. A method as defined in claim 38, wherein the amplifier is a first amplifier, and the filter includes a second amplifier, and wherein the output of the first amplifier is electrically coupled to a first input of the second amplifier, and an output of the second filter is electrically coupled to a second input of the second filter via a low pass filter.

40. A method as defined in claim 1, wherein the electronics module includes a converter to convert the signal of interest into digital form prior to transforming the signal of interest with the Fourier transform.

41. A method as defined in claim 1, wherein the electrical activity is from a muscle and a heart of the user.

\* \* \* \* \*

UNITED STATES PATENT AND TRADEMARK OFFICE  
**CERTIFICATE OF CORRECTION**

PATENT NO. : 9,351,658 B2  
APPLICATION NO. : 11/500678  
DATED : May 31, 2016  
INVENTOR(S) : Michael J. Lee et al.

Page 1 of 1

It is certified that error appears in the above-identified patent and that said Letters Patent is hereby corrected as shown below:

On the Title Page

Item (60) Related U.S. Application Data, insert:

-- Continuation of application No. 11/500,679, filed on Aug. 8, 2006, which claims priority to provisional application No. 60/706,580, filed on Aug. 9, 2005. --

In the Specification

Column 1, Lines 6-13 under "RELATED APPLICATIONS", delete the first two sentences:

"The present application claims priority from U.S. Provisional Application Ser. No. 60/713,899, filed on September 2, 2005 which is incorporated herein by reference. In addition, U.S. Patent Application Serial No. XX (Attorney Docket No. CAM-2) titled A Device and Method for Determining and Improving Present Time Emotional State of a Person which was invented by Ray Caamaiio et al. and which has the same filing date as the present application, is hereby incorporated by reference."

Insert, under "RELATED APPLICATIONS":

-- The present application claims the benefit of U.S. Provisional Application Ser. No. 60/713,899, filed on Sep. 2, 2005, which is hereby incorporated herein by reference. In addition, the present application arises from a continuation of U.S. Patent Application Ser. No. 11/500,679, filed August 8, 2006, which is hereby incorporated by reference. U.S. Patent Application Ser. No. 11/500,679 claims the benefit of U.S. Provisional Application Ser. No. 60/706,580, filed on August 9, 2005. --

Signed and Sealed this  
Thirty-first Day of January, 2017

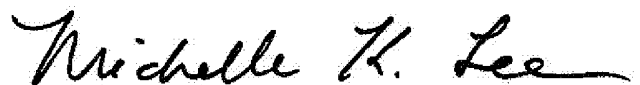

Michelle K. Lee  
Director of the United States Patent and Trademark Office

专利名称(译)	用于感测组织中的电活动的装置和方法		
公开(公告)号	<a href="#">US9351658</a>	公开(公告)日	2016-05-31
申请号	US11/500678	申请日	2006-08-08
[标]申请(专利权)人(译)	LEE MICHAEL J LEE HANS Ç		
申请(专利权)人(译)	LEE MICHAEL J LEE HANS Ç		
当前申请(专利权)人(译)	尼尔森公司 ( 美国 ) 有限责任公司		
[标]发明人	LEE MICHAEL J LEE HANS C		
发明人	LEE, MICHAEL J. LEE, HANS C.		
IPC分类号	A61B5/0476 A61B5/04 A61B5/048 A61B5/00		
CPC分类号	A61B5/0476 A61B5/0006 A61B5/048 A61B5/6814 A61B5/0002 A61B5/0015 A61B5/04012 A61B5/0478 A61B5/165 A61B5/6803 A61B5/742		
优先权	60/713899 2005-09-02 US		
其他公开文献	US20070055169A1		
外部链接	<a href="#">Espacenet</a> <a href="#">USPTO</a>		

摘要(译)

提供一个或多个改进的示例性实施例包括用于以基本上限制或消除周围环境中的噪声干扰的方式感测人的组织中的电活动的装置和方法。

