



US009104788B2

(12) **United States Patent**
Friedman et al.

(10) **Patent No.:** **US 9,104,788 B2**
(45) **Date of Patent:** **Aug. 11, 2015**

(54) **SYSTEM AND METHOD OF USING LOCATION TECHNOLOGY TO AID PATIENT RECOVERY**

(75) Inventors: **Bruce A. Friedman**, Jasper, GA (US); **Matthew Grubis**, New Berlin, WI (US); **Brian W. Nantz**, Milwaukee, WI (US); **Carl C. Davis**, Menomonee Falls, WI (US)

(73) Assignee: **General Electric Company**, Schenectady, NY (US)

(*) Notice: Subject to any disclaimer, the term of this patent is extended or adjusted under 35 U.S.C. 154(b) by 597 days.

(21) Appl. No.: **12/849,557**

(22) Filed: **Aug. 3, 2010**

(65) **Prior Publication Data**

US 2012/0035427 A1 Feb. 9, 2012

(51) **Int. Cl.**

- A61B 5/00** (2006.01)
- G01S 19/01** (2010.01)
- A61B 5/11** (2006.01)
- G01S 17/08** (2006.01)
- G06F 19/00** (2011.01)
- G01S 5/00** (2006.01)
- G01S 17/00** (2006.01)
- G01S 13/46** (2006.01)
- G07C 1/10** (2006.01)
- G07C 9/00** (2006.01)

(52) **U.S. Cl.**

CPC **G06F 19/327** (2013.01); **A61B 5/0002** (2013.01); **A61B 5/112** (2013.01); **G01S 17/08** (2013.01); **G01S 19/01** (2013.01); **G06F 19/34** (2013.01); **G06F 19/345** (2013.01); **G01S 2013/468** (2013.01); **G06F 19/3418** (2013.01); **G07C 1/10** (2013.01); **G07C 9/00111** (2013.01)

(58) **Field of Classification Search**

CPC A61B 5/0002; A61B 5/1113; A61B 5/02; A61B 5/72; G06F 19/3418; G06F 19/3406; G06F 19/345; G01S 5/0231; G01S 2013/468; G01S 19/01
USPC 340/853.1, 870.01, 870.05, 500-538, 340/539.1, 539.11, 539.12, 539.13, 539.14, 340/539.15, 539.2, 540, 546, 1.1, 2.1, 3.1, 340/4.1, 992, 993, 435, 286.01, 286.02, 340/286.07, 999; 600/300-301, 363-365, 600/372-374, 377-379, 382-384, 386-394, 600/481, 485, 500-503, 508, 515-519, 600/529-531, 544-547, 549, 587-595; 128/920-925; 705/2-3

See application file for complete search history.

(56) **References Cited**

U.S. PATENT DOCUMENTS

- 5,652,570 A * 7/1997 Lepkofker 340/573.4
- 6,135,970 A 10/2000 Kadhiresan et al.
- 6,838,992 B2 1/2005 Tenarvitz
- 6,847,892 B2 1/2005 Zhou et al.
- 6,998,978 B2 2/2006 Kirkeby

(Continued)

Primary Examiner — William Thomson

Assistant Examiner — Marie Archer

(74) *Attorney, Agent, or Firm* — Andrus Intellectual Property Law, LLP

(57) **ABSTRACT**

A system for telemetrically monitoring a patient includes a remote monitoring device associated with the patient. A location services system tracks a location of the remote monitoring device. A patient tracking computer calculates a distance and a duration of patient ambulation from the tracked location. A method of monitoring an ambulatory patient monitors the location of a remote monitoring device and derives ambulatory event data from the monitored location.

23 Claims, 6 Drawing Sheets

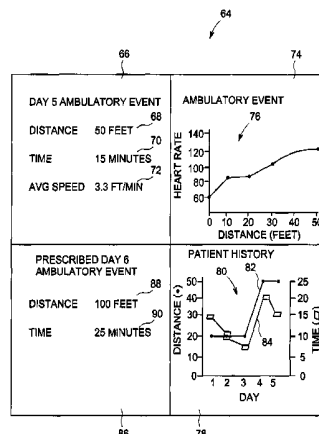
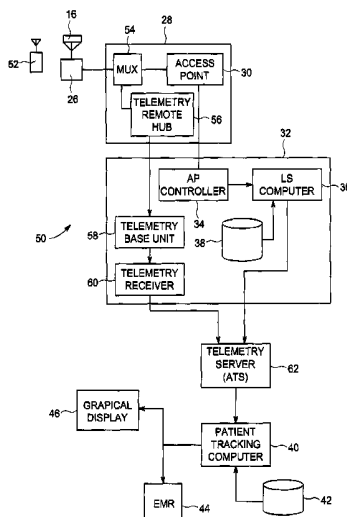

(56)

References Cited

U.S. PATENT DOCUMENTS

7,091,863	B2	8/2006	Ravet	2008/0274713	A1*	11/2008	Rofougaran	455/334
7,328,131	B2	2/2008	Donofrio et al.	2009/0184823	A1*	7/2009	Tessier	340/568.1
7,978,085	B1*	7/2011	Kearns et al.	2009/0224909	A1*	9/2009	Derrick et al.	340/539.13
2005/0258957	A1*	11/2005	Krumm et al.	2009/0322513	A1*	12/2009	Hwang et al.	340/539.12
2005/0270236	A1*	12/2005	Krumm et al.	2010/0022352	A1*	1/2010	Kasama et al.	482/1
2007/0085690	A1*	4/2007	Tran	2010/0094534	A1*	4/2010	Naick et al.	701/200
2007/0132577	A1*	6/2007	Kolavennu	2010/0097208	A1*	4/2010	Rosing et al.	340/539.13
2007/0273504	A1*	11/2007	Tran	2010/0097209	A1*	4/2010	Wong	340/539.13
2008/0001735	A1*	1/2008	Tran	2010/0134276	A1*	6/2010	Zaruba et al.	340/539.13
2008/0208446	A1*	8/2008	Geelen et al.	2010/0141432	A1*	6/2010	Sugla	340/539.13
2008/0221928	A1*	9/2008	Garcia et al.	2010/0249541	A1*	9/2010	Geva et al.	600/301
				2011/0125514	A1	5/2011	Molaison	
				2011/0172904	A1*	7/2011	Dayaratne	701/201
				2012/0290217	A1*	11/2012	Shoval et al.	702/19

* cited by examiner

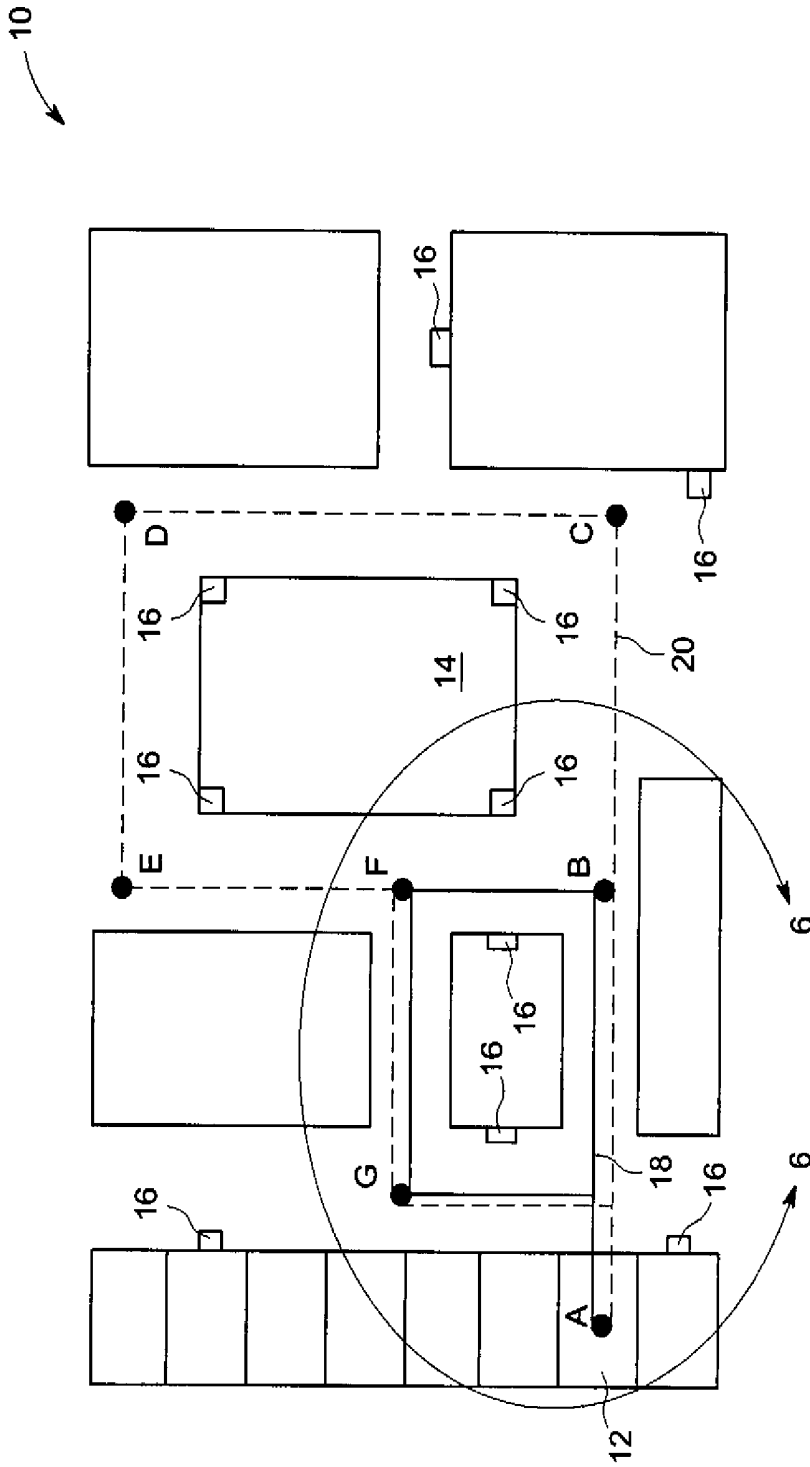

FIG. 1

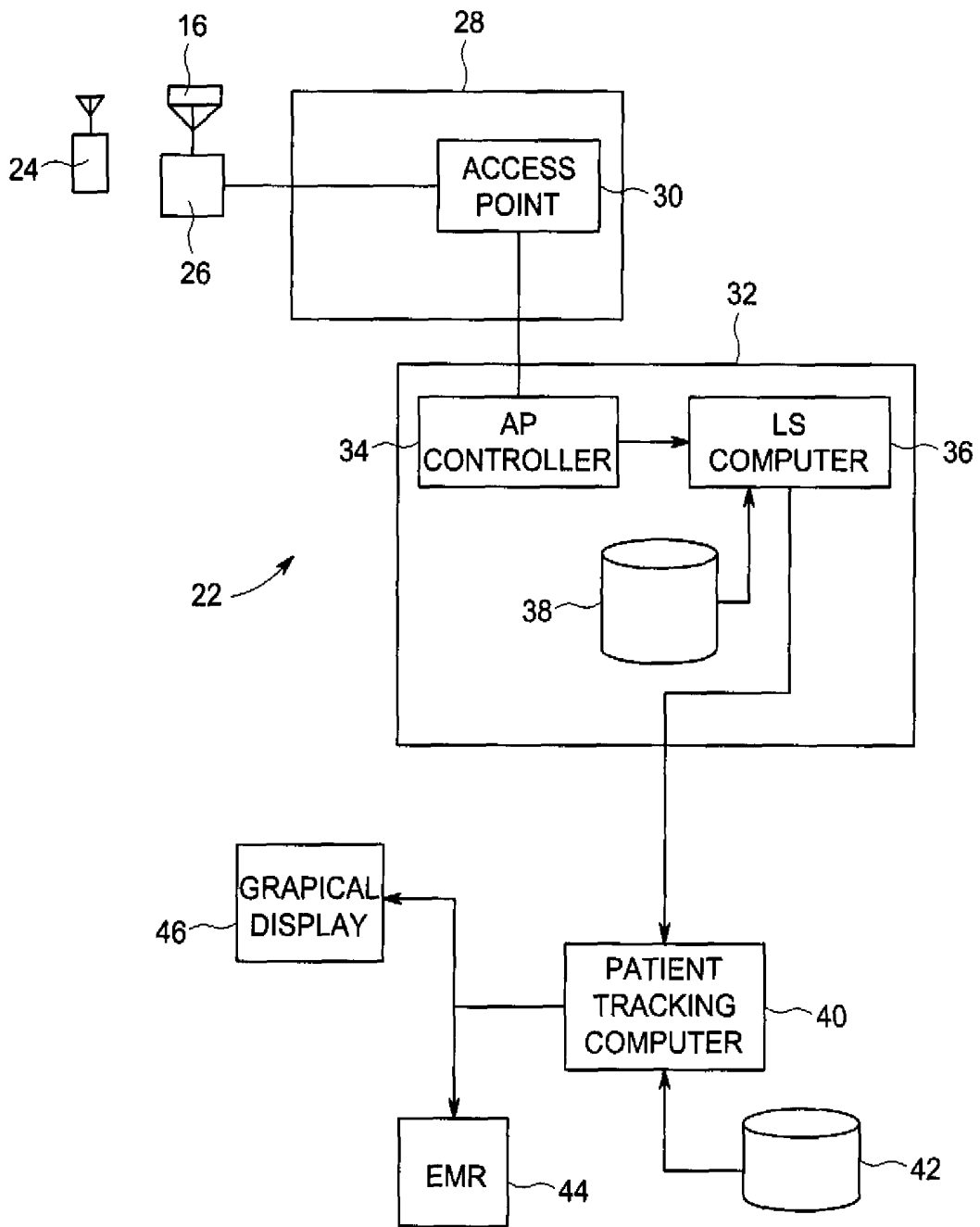

FIG. 2

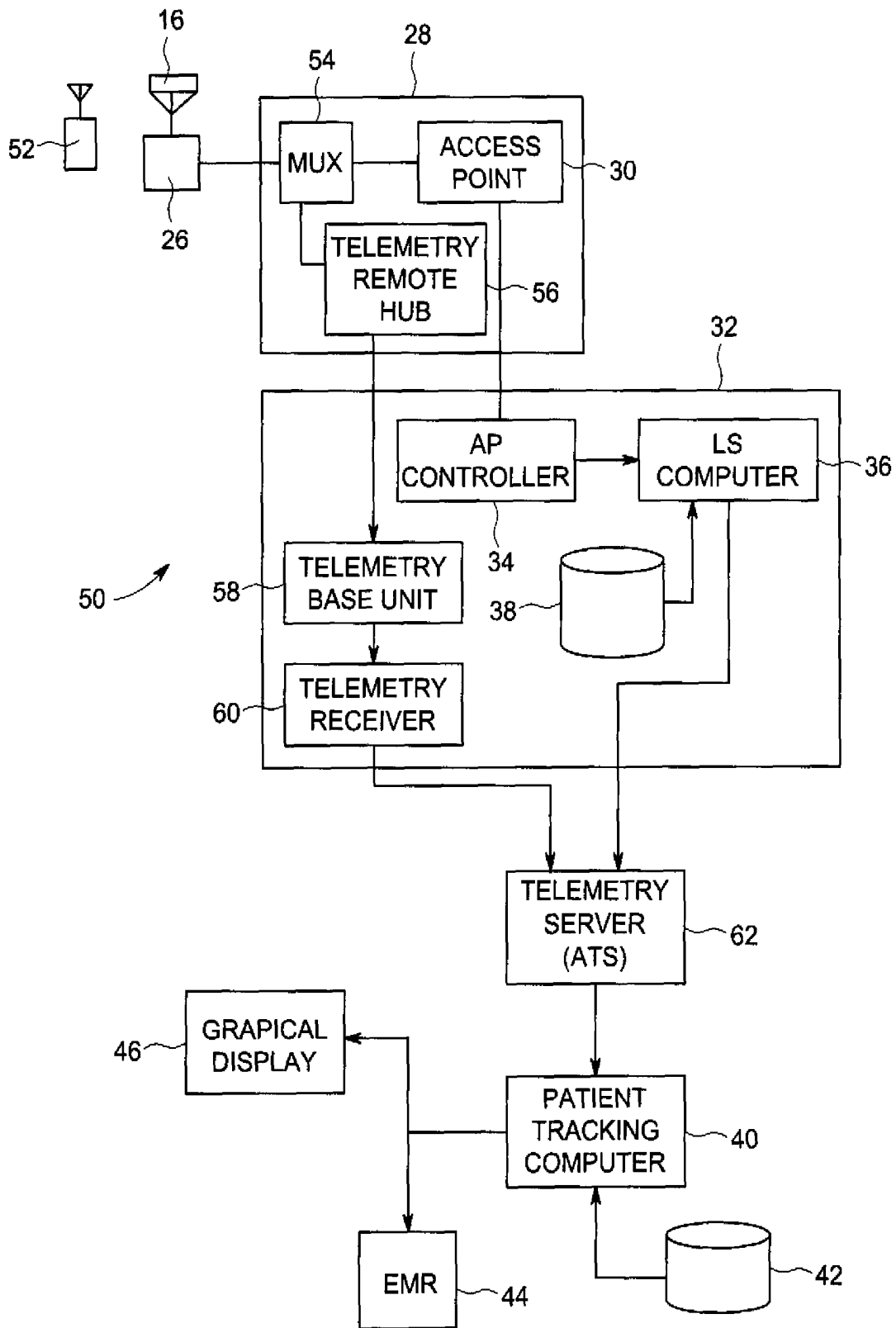

FIG. 3

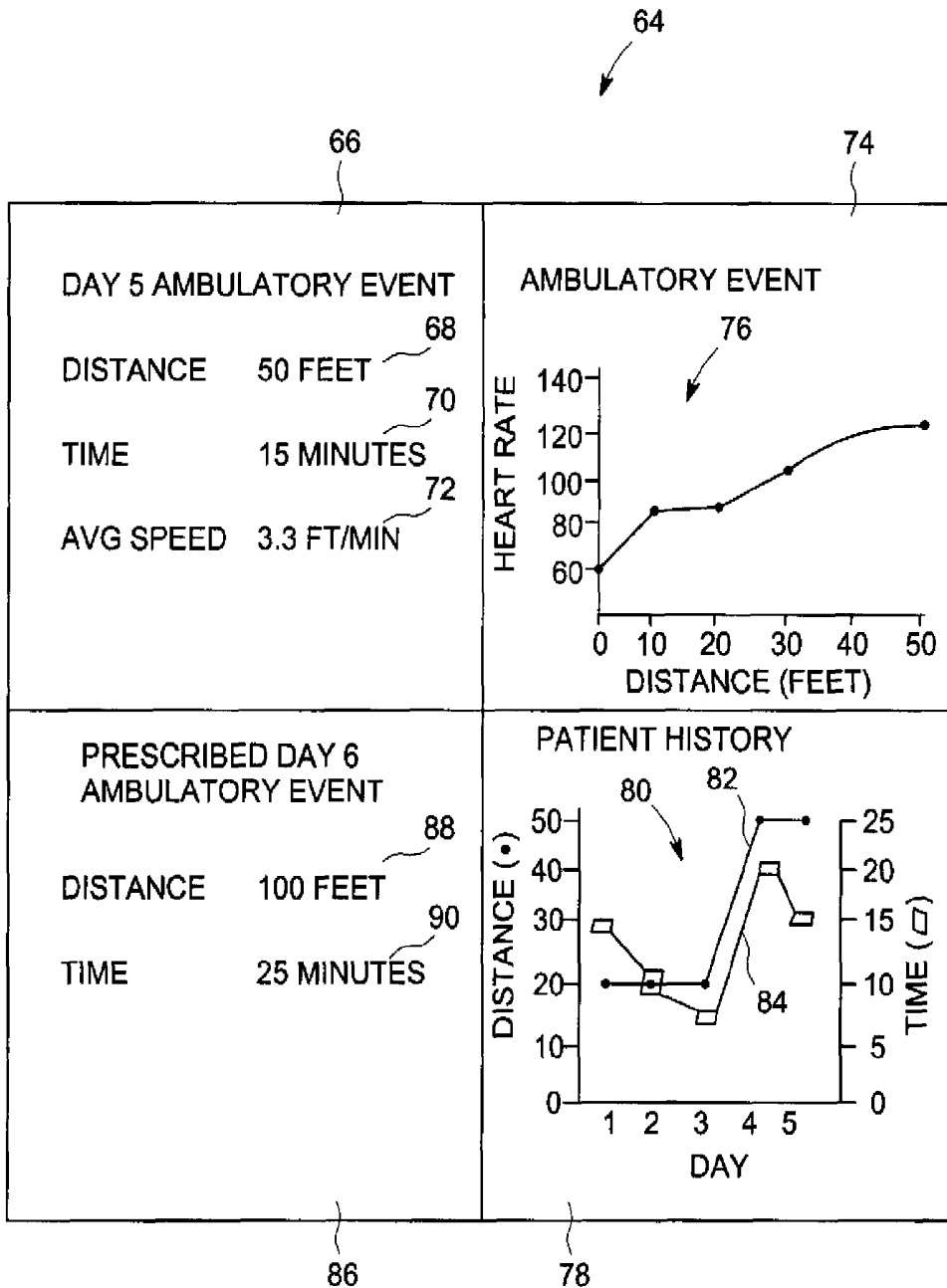

FIG. 4

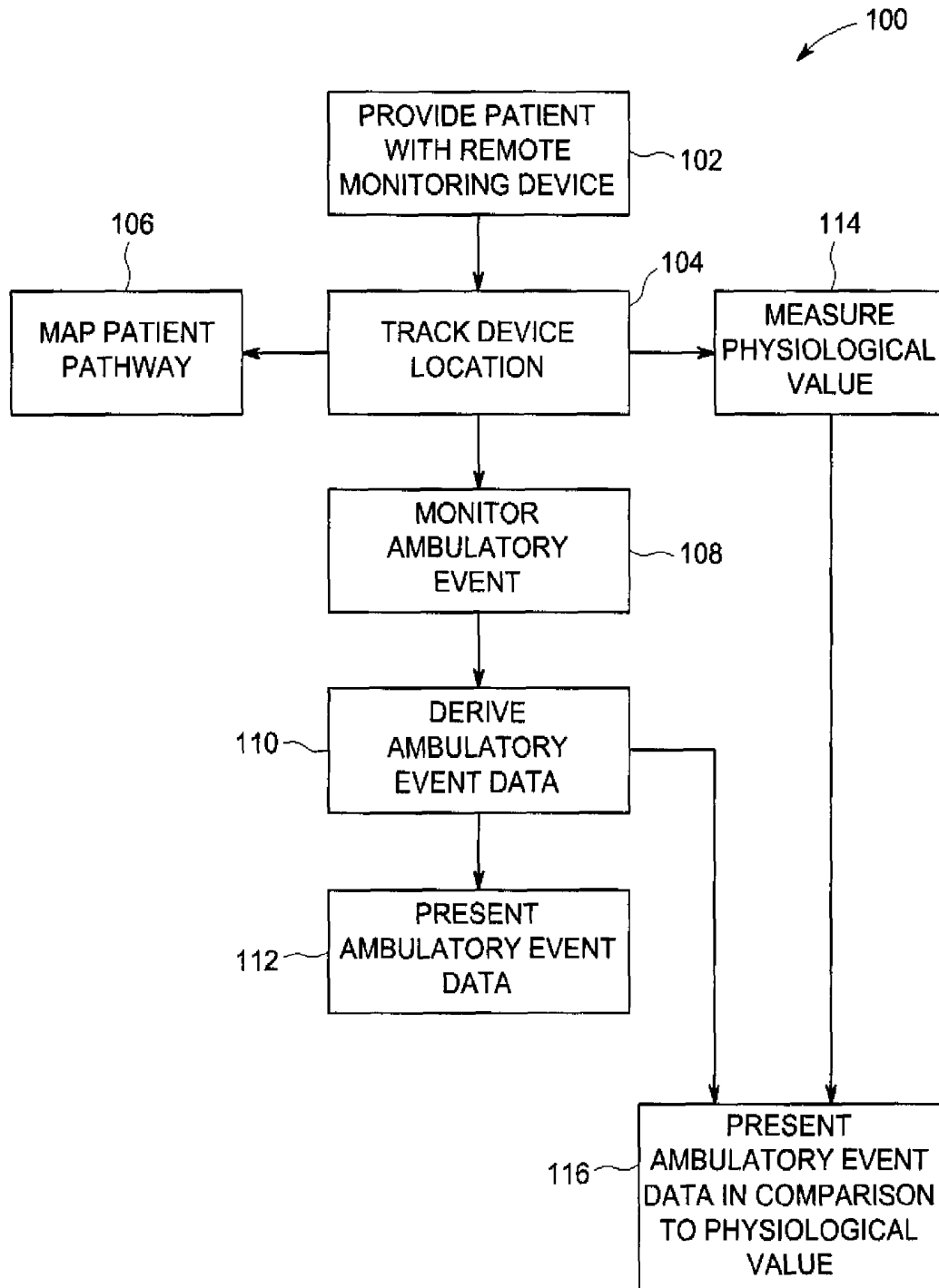

FIG. 5

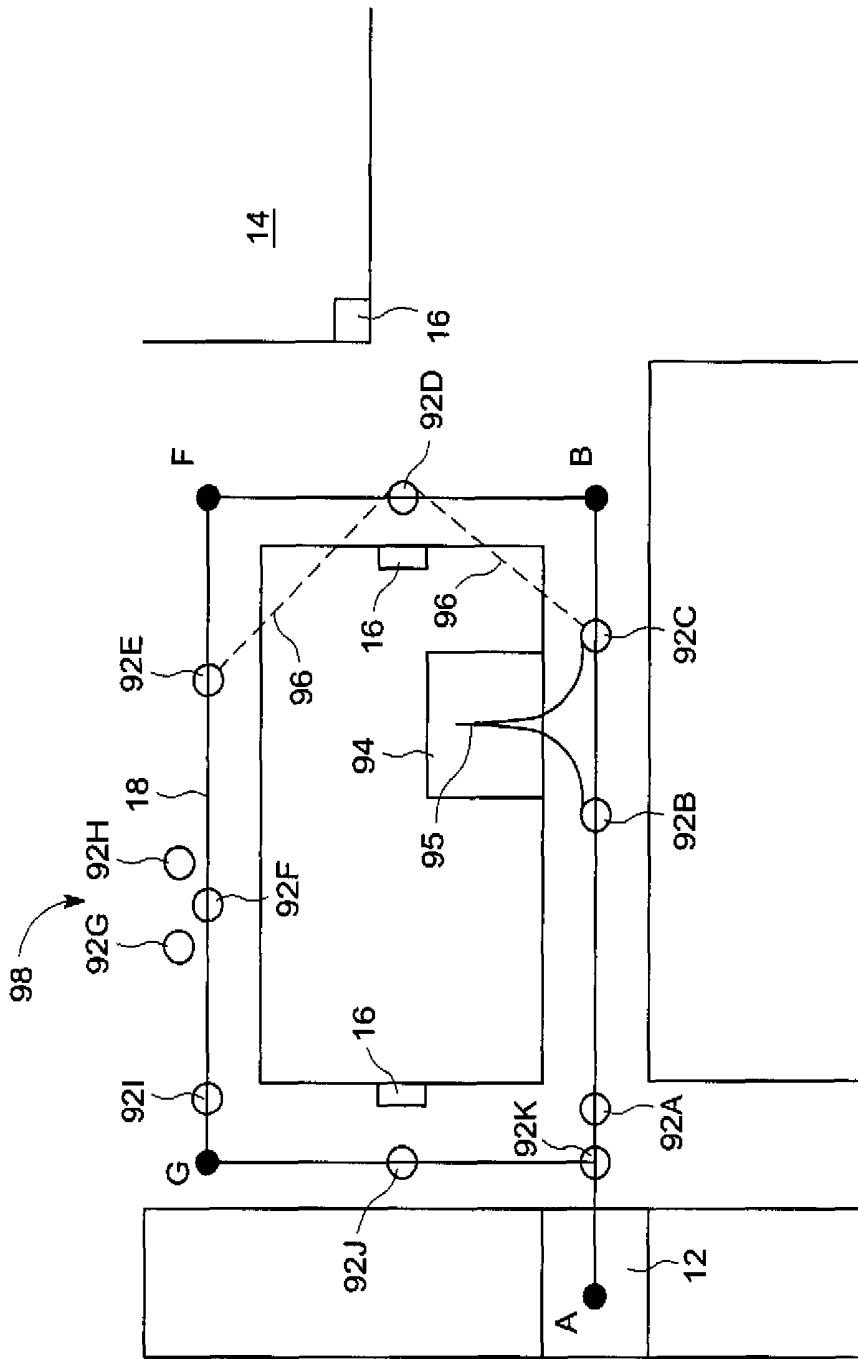

FIG. 6

SYSTEM AND METHOD OF USING LOCATION TECHNOLOGY TO AID PATIENT RECOVERY

BACKGROUND

The present disclosure is related to the field of telemetry. More particularly, the present disclosure is related to systems and methods of monitoring patient location in order to aid in patient recovery.

Patients recovering in telemetry wards or other hospital settings are often encouraged to exercise, if possible, by walking. Currently, this is merely encouraged or requested of the patient, but no specific demands are made.

In some settings, a patient may be provided with a pedometer that measures distance traveled by the patient over the course of a day, but this information must be manually recorded by a clinician and there is no ability to differentiate types of patient movement.

BRIEF DISCLOSURE

A system for telemetrically monitoring a patient includes a remote monitoring device associated with the patient. The remote monitoring device obtains a physiological value from the patient and broadcasts the physiological value. A location services (LS) system tracks a location of the remote monitoring device. A patient tracking computer is communicatively connected to the remote monitoring device and the LS. The patient tracking computer receives the physiological value and the location of the remote monitoring device and calculates a distance and a duration of a patient ambulation from the received locations.

An alternative embodiment of a system of monitoring an ambulatory patient includes a remote monitoring device associated with the ambulatory patient. A location services (LS) system tracks a position of the remote monitoring device. A patient tracking computer is communicatively connected to the LS system. The patient tracking computer receives the position of the remote monitoring device and the patient tracking computer calculates a distance traveled and an elapsed duration of an ambulatory event from the received positions of the remote monitoring device.

A method of monitoring an ambulatory patient includes providing the ambulatory patient with a remote monitoring device. A location of the remote monitoring device is tracked with a location services (LS) system. An ambulatory event is monitored with a patient tracking computer. The patient tracking computer is communicatively connected to the remote monitoring device and the LS. Ambulatory event data is derived from the tracked location. The ambulatory event data includes an ambulatory event distance and an ambulatory event time.

BRIEF DESCRIPTION OF THE DRAWINGS

FIG. 1 depicts a floor plan with alternative ambulatory event routes and a plurality of telemetry receivers.

FIG. 2 is a schematic diagram depicting an embodiment of a telemetry system.

FIG. 3 is a schematic diagram depicting an alternative embodiment of a telemetry system.

FIG. 4 depicts an exemplary embodiment of a graphical user interface used in connection with embodiments of the system and method.

FIG. 5 is a flow chart depicting an embodiment of the method of monitoring an ambulatory patient.

FIG. 6 is a more detailed depiction of a portion of the floor plan of FIG. 1 denoted by line 6-6 of FIG. 1.

DETAILED DISCLOSURE

FIG. 1 depicts a floor plan 10 of a telemetry ward or other clinical setting. The floor plan 10 includes a variety of exemplary landmarks on the floor. These landmarks include a patient's room 12 and a nursing station 14. Additionally, the floor plan 10 exemplarily includes a plurality of telemetry receivers 16 disposed throughout the floor plan 10. Embodiments of the systems and methods incorporating one or more of these telemetry receivers 16 will be described in further detail herein. It is to be understood that alternative embodiments do not include a plurality of telemetry receivers 16, as will also be explained in further detail herein.

The floor plan 10 further includes two alternative routes 18, 20 for an ambulatory patient to travel. A short route 18 is represented by a solid line that connects the path A-B-F-G. A long route 20 is represented by a dashed line and follows the path represented by A-B-C-D-E-F-G.

FIG. 2 is a schematic diagram of one possible arrangement for a location services (LS) system 22. This includes a remote monitoring device 24. The remote monitoring device 24 is associated with a particular patient within the telemetry ward. In an embodiment, the remote monitoring device 24 is a wireless electronic communication device that is worn or otherwise attached to the patient.

The remote monitoring device 24 broadcasts a location signal in radio frequency (RF) that is indicative of the location of the remote monitoring device 24 and the associated patient. The location signal may take a variety of forms. Non-limiting examples of location signals may include a beacon that is triangulated by beacon sensors, such as telemetry receivers 16. Alternatively, the remote monitoring device 24 may include a global positioning system (GPS) technology such that the remote monitoring device 24 is able to determine a coordinate for its location. The location signal may then be a broadcast of this determined location coordinate. In a still further embodiment, the remote monitoring device may be a physiological monitoring device, as will be described in greater detail herein with respect to an alternative embodiment. In such an embodiment, the remote monitoring device 24 may obtain and broadcast physiological data from the patient. The broadcast signal with the physiological data may also be triangulated in order to determine the location of the remote monitoring device 24.

The technology used by the monitoring device 24 to broadcast the location signal may be any of a variety of known broadcast technology. This includes the above-referenced radio frequency (RF) technology. Alternatively, the location signal may be broadcast in the form of infrared (IR) or ultrasound; however, these are not limiting on the technologies that may be used to broadcast the location signal.

As noted above, embodiments of the location services system 22 may include a plurality of telemetry receivers 16 that receive the signals broadcast by the remote monitoring device 24. It is to be understood that the plurality of telemetry receivers 16 will be designed to receive the type of signal broadcast by the remote monitoring device 24. As such, the telemetry receivers 16 may be receivers configured to receive RF, IR, ultrasound, or other broadcast technology. It is to be further understood that the number and location of telemetry receivers distributed throughout a telemetry ward may be dependent upon the broadcast technology used. Therefore, in some embodiments a plurality of telemetry receivers 16 may be

distributed throughout the area, while in other embodiments only a single telemetry receiver may be necessary.

The telemetry receivers **16** are connected to an amplifier that amplifies the signal received by the telemetry receiver **16**. Although not depicted, the amplifier **26** may also include other forms of signal conditioning or processing, including, but not limited to, filtering and/or digitization.

Signals from the amplifier **26** are transmitted to a remote closet **28**. The remote closet **28** is connected to each of the plurality of telemetry receivers **16** located in a defined area. In one example, the medical care facility includes a telemetry ward that expands to multiple floors of the medical care facility. In such an example, a remote closet **28** may be placed at each of the floors in order to collect and process the signals received by the telemetry receivers **16** on that floor.

The remote closet **28** directs the received location signals from the telemetry receiver **16** to an access point **30**. The access point **30** measures the strength of the location signals from the remote monitoring device **24** that are received by one or more telemetry receivers **16**. In the location services system **22** wherein a plurality of telemetry receivers **16** are distributed throughout the telemetry coverage area, the strength of the location signals received at each of the telemetry receivers **16** as determined by the access point **30** can be used to triangulate the remote monitoring device as the varying signal strength from a plurality of telemetry receivers **16** may be used to determine the patient location with reference to each of the telemetry receivers **16** receiving the location signal.

The access point **30** of the remote closet **28** provides the location information, including the received signal strengths, to a main closet **32**. The main closet **32** collects all of the information from the plurality of remote closets **28** distributed throughout the location services system **22**. The access point **30** of the remote closet **28** provides the location information, including the received signal strengths, to the main closet **32** through any number of information transmission technologies, including wired, wireless, or fiber optic technologies. An access point (AP) controller **34** is connected to each of the access points **30** when a plurality of remote closets **28** exist in the location services system **22**. The AP controller **34** coordinates the transmission and reception of the location information from the access points **30** of each of the remote closets **28**.

The location information is provided from the AP controller **34** to a location services (LS) computer **36**. The LS computer includes computer readable code stored on a computer readable medium **38** that embodies software as detailed further herein for calculating location information regarding a patient.

The LS computer **36** operates according to the computer readable code embodied on the computer readable medium **38** such that the LS computer **36** tracks the location of the remote monitoring device **24** based upon a received location signal. The LS computer **36** may track the location of the remote monitoring device **24** as a plurality of locations in real-time (RI), or in near-real-time, as determined by the refresh rates of the access point **30** and AP controller **34**. Alternatively, the LS computer **36** may track the location of the remote monitoring device **24** at any alternative appropriate time interval as would be recognized by one of ordinary skill in the art. Therefore, some embodiments may refresh the tracked patient location every second, while alternative embodiments may determine location every minute; however, these are merely exemplary and are not intended to be limiting on this disclosure.

The tracked patient location of the remote monitoring device **24** is transmitted from the LS computer **36** of the main closet **32** to a patient tracking computer **40**. The patient tracking computer **40** can be connected to a computer readable medium **42** which contains computer readable code that upon execution by the patient tracking computer **40**, causes the patient tracking computer **40** to carry out the processes and functions as disclosed herein.

The patient tracking computer **40** receives the plurality of tracked patient locations of the remote monitoring device **24** from the LS computer **36** and calculates at least one of a variety of patient ambulatory event data from the received plurality of tracked patient locations. The ambulatory event data may include a total distance traveled by the remote monitoring device **24**.

In order to facilitate data processing, the tracking of the remote monitoring device **24** location may be broken into one or more ambulatory events. Each ambulatory event would have a defined beginning and a defined end. Therefore, the patient tracking computer **40** may determine a distance traveled by the remote monitoring device **24** over the course of an ambulatory event. Alternatively, the patient tracking computer **40** may calculate a time duration of the ambulatory event. In still further embodiments, the patient tracking computer **40** may calculate an average or an instantaneous speed of the patient during the ambulatory event from the calculated distance and the calculated duration, as disclosed above with respect to alternative embodiments.

The patient tracking computer **40** may calculate the ambulatory event data using one or more algorithms stored on the computer readable medium **42**. In an exemplary embodiment of the algorithms used to calculate the ambulatory event data, the patient tracking computer may calculate the distance traveled between track patient location as a straight line between the two locations. A more advanced algorithm may be used to calculate the distance traveled as an average distance traveled by tracked patients between similar locations.

In a still further embodiment, which will be described in greater detail herein, and particularly with respect to FIG. **6**, the algorithms used by the patient tracking computer **42** to calculate the ambulatory event data may calculate the distance traveled by the patient between two tracked patient locations based upon a probability analysis of various patient paths. Such probabilities may be developed over time by monitoring location information for various ambulatory patients. This patient location information may be analyzed using an advanced neural network (ANN) or Bayesian analysis to determine likely patient routes between two tracked patient locations. These likely patient routes are then used to derive the distance traveled by the patient between the two tracked patient locations. The advanced neural network or Bayesian analysis of historical patient location information may result in an algorithm that consists of probabilities or Gaussian distributions related to the actual path taken by a patient between two tracked patient locations.

The patient tracking computer **40** is communicatively connected to an electronic medical record (EMR) **44** of the patient such that the ambulatory event data may be stored as part of the patient's electronic medical record **44**. The recording of the ambulatory event data in the patient's EMR **44** allows for the ambulatory event data to be used as a physiological parameter to be considered in the evaluation of the patient's medical status. Furthermore, the ambulatory event data calculated by the patient tracking computer **40** may be sent to a graphical display **46**. The graphical display **46** presents the calculated ambulatory data to a clinician, the patient, or the patient's friends or family. As will be disclosed in

further detail herein, the presentation of ambulatory data to non-medical personnel, such as the patient or the patient's friends and family, may provide additional benefits in expressing the patient's condition and/or progression towards recovery in a non-technical format.

FIG. 3 depicts a schematic diagram of a telemetry system 50 that incorporates the location services system 22 (depicted in FIG. 2). It is to be noted that like numerals between FIGS. 2 and 3 represent like elements to which the description with respect to FIG. 2 applies. Therefore, only those new elements found in the telemetry system 50 will be described in greater detail herein with respect to FIG. 3. The telemetry system 50 is an exemplary embodiment of a system wherein an RF signal bearing physiological data from the remotely monitored patient is triangulated and used to identify the patient's location.

The remote monitoring device 52 of the telemetry system 50 further monitors at least one physiological value from the patient and broadcasts the at least one physiological value exemplarily using RF, although other technologies such as IR or ultrasound may be potentially used. A non-limiting example of the types of physiological values that may be obtained by the remote monitoring device 52 includes heart rate, an electrocardiogram (ECG), non-invasive blood pressure (NIBP), and SpO₂. However, this list is merely exemplary and is not intended to be limiting on the scope of physiological values that may be obtained from the patient by the remote monitoring device 52.

The remote monitoring device 52 broadcasts the at least one physiological value obtained from the patient. In such an embodiment the location of the remote monitoring device 52 may be derived from the broadcast at least one physiological value. In an alternative embodiment, the remote monitoring device 52 may also broadcast an independent location signal, as described above with respect to FIG. 2. In one such embodiment, the telemetry signals are broadcast at a low frequency and the location signals are broadcast at a high frequency. This facilitates the separation of the broadcasted physiological values from the broadcasted location. In an alternative embodiment the telemetry signals and the location signals are broadcast using two different broadcast modalities. In one exemplary embodiment, the telemetry signal is broadcast in RF while the location signal is broadcast in IR.

The at least one physiological value is transmitted through the telemetry receiver 16 and amplifier 26 to the remote closet 28. A multiplexer 54 receives the broadcast physiological signal and the location information. In one embodiment, the multiplexer 54 separates a lower frequency telemetry signal from a higher frequency location signal and directs the received signals to the appropriate components of the telemetry system 50 for further processing. In an alternative embodiment separate receivers are distributed to receive separate broadcasts of telemetry and location signals.

From the multiplexer 54, the physiological values are provided to a telemetry remote hub 56 that prepares the physiological values for transmission from the remote closet 28 to the main closet 32. The telemetry remote hub 56 may transmit the physiological values to a telemetry base unit 58 in the main closet 32. The telemetry base unit 58 receives and processes the physiological values. In an embodiment, the transmission of the physiological values from the telemetry remote hub 56 to the telemetry base unit 58 is performed by fiber optic transmission technology and the telemetry remote hub 56 and the telemetry base unit 58 perform the signal conditioning required for the optical fiber conversion necessary for the transmission.

After the physiological values are transmitted from the telemetry remote hub 56 to the telemetry base unit 58, the telemetry base unit 58 processes the fiber optic signal to extract the physiological values embedded thereon. The telemetry base unit 58 sends the physiological values to a telemetry receiver 60 that receives physiological values and further directs the physiological values to a telemetry server (ATS) 62. The ATS 62 performs further analysis of the received physiological values, such as to process the received physiological values into appropriate forms for storage and interpretation. Additionally, if the telemetry system 50 is part of a broader system for telemetrically monitoring the physiological condition of a patient, the ATS 62 may derive additional physiological data from the received physiological values and/or apply institutional diagnostic rules such as to perform automatic or automated diagnostic tests or other patient monitoring.

The ATS 62 also receives the broadcast locations of the patient from the LS computer 36. The ATS 62 may coordinate the physiological values and the locations from the patient with other patient, facility, or services information that may be necessary for the operation of other features of the telemetry system 50 that are not central to the present disclosure. Such additional telemetry systems functionalities include patient medical history and EMR access, clinical staff information, medical care facility availability, and facility capacity.

The ATS 62 transmits all of the physiological values and the patient locations to the patient tracking computer 40. In addition to the ambulatory event data calculated by the patient tracking computer 40 as disclosed with respect to FIG. 2, when the patient tracking computer 40 further receives physiological values from the ATS 62, the patient tracking computer may further calculate a correlation or other relationship between the at least one physiological value and the ambulatory event data. Merely exemplary embodiments of such correlations may include a comparison of ambulatory event duration to patient heart rate, S_pO₂, or blood pressure. Alternative comparisons may similarly be drawn between the ambulatory event distance and the physiological values noted above.

In still further embodiments, because the distance, duration, and/or speed of the ambulatory event is known, this ambulatory event data may be compared to a physiological value such as a measurement of the patient's ECG. In this embodiment, the ambulatory event monitored by the telemetry system 50 can be analyzed as a form of stress test wherein changes to ECG morphology may be monitored with respect to an ongoing physical stress to the patient. The types of morphological analyses performed on ECG data are known to persons of ordinary skill in the art of stress tests. It is understood that while ECG has exemplarily been identified as the physiological value evaluated in the stress test, alternative physiological values may also be used in this analysis.

The patient tracking computer 40 is connected to the patient's electronic medical record (EMR) 44 such that the results of these correlative analysis may be recorded as part of the patient's electronic file. Similarly, the results of these comparison between ambulatory event data and physiological values may be sent to a graphical display 46 for presentation to clinicians, the patient, or others.

FIG. 6 is a more detailed depiction of an embodiment of a portion of the floor plan of FIG. 1 denoted by line 6-6. FIG. 6 will herein be used to describe additional features of embodiments of the system and method for monitoring an ambulatory event. More specifically, the floor plan of FIG. 6 depicts

an embodiment wherein the patient location is only intermittently determined or broadcast by the remote monitoring device.

In FIG. 6, a plurality of position beacons 92 A-K denote the actual position of the patient as determined by the location services system. These beacons 92 A-K exemplarily represent constant time intervals. As a merely exemplarily embodiment, the location services system determines actual patient location identified by the beacons 92 A-K once every minute; however, it is understood that the intervals between the beacons 92 A-K may be more or less including intervals that approach or achieve real-time or near-real-time.

Returning to the exemplary embodiment of FIG. 6, the patient completes the short route 18 while on the path of A-B-F-G-A over the course of approximately 11 minutes, as represented by the eleven beacons 92 A-K.

When the patient location is only intermittently derived, algorithms must be implemented in order to sufficiently track the ambulatory event, and accurately monitor the distance traveled by the patient during the ambulatory event.

As mentioned above, the algorithms used to calculate the distance traveled by the patient during the ambulatory event may range in complexity from a simple straight line path between position beacons to a more detailed analysis that incorporates information regarding the likelihood of a patient to travel along a particular path between two position beacons. These algorithms may be derived through an analysis of historical patient movements across a large number of patients on the same ambulatory route or in the same ambulatory ward. Additionally, the algorithms may be nuanced or particularized to specific patients after sufficient ambulatory information for a particular patient is acquired. This historical patient location information may be used to identify percentages or likelihoods that a patient will take a particular path (with a defined distance) between two position beacons. The algorithms used to calculate the distance traveled between two position beacons may be derived using a form of analysis such as an advanced neural network or Bayesian analysis. As noted above, the results of this analysis of historical patient location information may be probability or Gaussian distributions related to particular patient paths between position beacons.

Information regarding the likelihood of patients to choose particular paths and/or destinations may be incorporated into both the tracking of patient location during the ambulatory event and the calculation of the distance traveled during the ambulatory event. For example, a room 94, such as a bathroom, may exist between beacons 92B and 92C. Due to the interval between these two beacons, it may be that the distance traveled by the patient may be accurately represented by a straight line between beacons 92B and 92C. Alternatively, the patient's path may be more correctly represented by line 95 that quickly enters the bathroom 94 and exits the bathroom 94 before the patient's location is determined again.

The above-noted analysis of historical patient location information may identify that it is very unlikely that the patient would enter a room, such as bathroom 94, for only a few seconds, such that a location beacon would not appear in the bathroom 94. Exemplarily, the algorithm may identify that there is a 10% chance that the patient traveled path 95 while there is a 75% chance that the patient traveled directly between 92B and 92C. Thus, in such a situation, it may be accurately reflected that the patient most likely proceeded directly between beacon 92B and 92C during the ambulatory event. A travel distance calculated by the algorithm may be adjusted to account for these percentages, either selecting the distance of the most likely path or by providing a weighted

average of the alternative path distances weighted by their likelihood percentages. These models or estimates may be adjusted based upon the patient's average speed or instantaneous speed at the previous beacon (92B). This additional ambulatory event data can promote more accurate tracking of patient ambulation paths and distances.

Another consideration is the specific layout of the short ambulatory route 18 itself. While a direct positional measurement between beacons 92C and 92D would represent the shortest distance between these two adjacent beacons, information regarding the ambulatory route itself may be programmed such that it is known by the system that a direct path 96, such as between beacon 92C and 92D or 92D and 92E, is not possible due to the physical constraints of the hallway of the short route 18 itself. In such an instance, an algorithm executed by the patient tracking computer may assign a probability of 0% to a direct path between beacons 92C and 92D, or any other possible path that intersects the wall of the hallway. Thus, the ambulation distance respectively between beacons 92C and 92D or 92D and 92E must compensate for the corner of the hallways that must be traversed by the patient. As with the example above, a favored or most probable path between 92C and 92D (and an associated distance) may be identified through the analysis of historical patient location information.

A still further example of intermittent beacon interpretation is represented by group 98 of beacons 92F, 92G, and 92H. Since each of the beacons in group 98 are within close proximity to one another, the location services system may interpret this group 98 in a variety of ways. In one embodiment, the location services system may interpret that the patient has moved great distances between consecutive beacons, however, was in roughly the same position each time that these beacons were obtained. Alternatively, the location services system may interpret that the patient has remained generally still and thus little total distance was traversed during this time interval. As with the interpretation regarding the bathroom 94, compiled ambulatory data from a plurality of historical patients traversing the short ambulatory route 18 may be used to provide statistical guidance with respect to the proper interpretation of beacon group 98.

It is unlikely that a slowly moving patient would quickly cover distances back and forth while beacons are obtained at roughly the same position. Therefore, an exemplary patient location algorithm may assign a low probability of 5% to that analysis. Alternatively, the analysis of historical patient location information may identify that such a group 98 or pattern of position beacons likely (80%) can be interpreted that the patient paused during the ambulatory event, for example to converse with another patient or a caregiver. In this exemplary embodiment the location services system may assume that beacon group 98 is a result of the patient stopping, and process the beacon group 98 by removing the two "unused" intervals (namely 92F-92G and 92G-92H) from the ambulatory event and simply interpret the event as though the patient moved from beacon 92E to beacon 92F and then to beacon 92I. Alternative embodiments of the location services system may include a most probable path that incorporates all of the beacons of beacon group 98. This would have the effect of increasing the calculated time required by the patient to complete the ambulatory event while minimally increasing the distance covered. These adjustments would result in a lowered calculated average speed over the course of the ambulatory event.

FIG. 4 depicts an embodiment of a graphical user interface (GUI) 64 that may be presented on the graphical display 46 (FIGS. 2 and 3). The GUI 64 depicts exemplary embodiments

of the ambulatory event data that may be presented on the graphical display **46**. The merely exemplary GUI **64** is divided into four regions that each generally represent a different type of ambulatory event data that may be presented on the GUI **64**. It is to be understood that alternative embodiments of the GUI **64** may include more or fewer of these types of ambulatory event data.

Region **66** identifies information regarding the current day's (exemplarily Day 5) ambulatory event. This includes reporting a distance **68** traveled by the patient during the ambulatory event. A time **70** is reported for the patient to complete the prescribed ambulatory event. Finally, an average speed **72** is calculated from the distance **68** and time **70** and reported in region **66**.

Region **74** presents a graph **76** depicting a comparison between a physiological value and ambulatory event data from the Day 5 ambulatory event. The chart depicts the change in a patient's heart rate over the course of this single ambulatory event. The progress of the ambulatory event may be represented in terms of distance (feet) as in graph **76**. Alternatively, the ambulatory event progress may be represented in terms of event duration (time). As represented in the graph **76**, over the course of the ambulatory event the patient's heart rate increases from approximately 60 beats per minute to approximately 120 beats per minute. However, the graph **76** also shows that this increase is step-wise with plateaus rather than a steady increase. This graphical representation of the change in the patient's heart rate may provide assistance in evaluating patient condition as the patient's physiological response in the form of heart rate is correlated to the stress of the prescribed ambulatory event.

Region **78** presents a historical representation of a series of daily ambulatory events. This graphic may be obtained from information in the patient's EMR. Region **78** includes a chart **80** that reports the varying distances and times for each daily ambulatory event of the patient. Looking at the distance graph **82**, it can be seen that the ambulatory event distance increased from 20 feet to 50 feet between Day 3 and Day 4. By reviewing the distance graph **82** with the context provided by the time graph **84**, it can be readily identified that the patient's time to complete the prescribed 20 foot ambulatory event steadily decreases from 15 minutes to 7 minutes. After the patient completed the 20 foot ambulatory event on Day 3 in 7 minutes, the distance for the ambulatory event in Day 4 was increased to 50 feet. While the specific distances and times used in the present description are merely exemplary, this example shows how an improvement in patient performance in a prescribed ambulatory event over time can result in adjusting the ambulatory event in order to continue the patient's recovery process. This recovery process can also be noted in the decrease in time for the patient to complete the 50 foot ambulatory event between Day 4 and Day 5.

The graphical depiction of historical ambulatory event data as presented in chart **80** can be a useful tool for presenting patient condition and recovery to patients, or their family and friends who do not have medical training. By relating patient recovery and improvement to a real world task, such as an ambulatory event (walking a defined distance), patients and others presented with this data, may have a better understanding of their physiological condition. The graphical presentation of the ambulatory event data can provide a goal or other motivation in order to improve. Such improvement is visually seen and reinforced with each decrease in time for the completion of an ambulatory event. The patient is rewarded and challenged due to their improvements by increasing the distance of the next ambulatory event.

Region **86** presents a prescribed ambulatory event for the next day (Day 6). Since the patient reduced the time needed to complete the 50 foot ambulatory event between Day 4 and Day 5, the prescribed ambulatory event for Day 6, presented in region **86**, is established at a distance **88** of 100 feet. The prescribed completion time **90** for this ambulatory event is set at 25 minutes. This presents the patient with a new ambulatory goal, thus motivating the patient to continue progress towards recovery.

The GUI **64**, presented in FIG. 4, thus provides a patient without medical training a visual report that shows current ambulatory performance in relation to physiological parameters and previous ambulatory event performance. This presentation of monitored physiological parameters in context with a real-world activity can facilitate an understanding of current medical status by the patient and motivate the patient to improve in ambulatory performance, aiding in recovery. The patient is further positively challenged by a prescribed ambulatory event that is based upon the patient's previous ambulatory event performance.

Relating FIG. 1 to FIG. 4, the short route **18** and the long route **20** depicted on the floor plan **10** of the telemetry ward, may relate to actual predetermined ambulatory event routes. In an exemplary embodiment, the short route **18** may represent a prescribed ambulatory event of a distance of 20 feet. Thus, when the patient is prescribed a 20 foot ambulatory event, the patient is instructed to follow the route A-B-F-G. In some telemetry wards, this may be represented by a physical line drawn with a specified color on the floor of the halls of the telemetry ward. Continuing with this example, the long route **20** may be representative of an ambulatory event distance of 50 feet. Therefore, when prescribed with a 50 foot ambulatory event, the patient will follow the route A-B-C-D-E-F-G. For longer ambulatory events, the patient may combine routes or make multiple laps of defined routes. Therefore, for the prescribed Day 6 ambulatory event distance of 100 feet, the patient may be instructed to follow the long route **20** for two laps before completion. In another example, a 70 foot ambulatory event may be prescribed by completing one lap of the short route **18** and one lap of the long route **20**; however, these are intended to be merely exemplary of prescribed ambulatory event routes.

FIG. 5 is a flow chart depicting an embodiment of a method of monitoring an ambulatory patient **100**. The method **100** begins with providing the ambulatory patient with a remote monitoring device **102**. As noted above, the remote monitoring device may be a wireless device that is attached to, located on, or associated with the patient. The remote monitoring device may be specifically designed to track patient location; however, alternative embodiments of the remote monitoring device may also monitor physiological parameters from the patient. Such physiological parameters may include, but are not limited to, heart rate, NIBP, ECG, and SpO₂.

At **104**, the location of the remote monitoring device is tracked. As noted above, the tracking of the remote monitoring device location may be performed in a variety of manners by a location services system. The location services system may be based upon GPS coordinates that are transmitted from the remote monitoring device. Alternatively, the local services system may track a radio frequency (RF) or infrared (IR) signal from the remote monitoring device that is indicative of the location of the remote monitoring device. In some embodiments, the RF or IR signal may be triangulated by the location services system to track the device location. Additionally, the location services system may be a real-time location services (RTLS) system.

In an optional embodiment, a patient pathway may be tracked at **106** by the LS system. By concatenating a series of tracked device locations from **104** over time, a pathway of the patient during an ambulatory event may be mapped. The mapping of the patient pathway at **106** may be performed using a probability analysis as disclosed above using historical patient location information to provide a likelihood, which may be a percentage, that the patient took a particular path between detected location beacons. The mapped pathway may be stored for later reference, such as in the development of more detailed algorithms to interpret patient movement between location beacons. Alternatively, the mapped pathway may be presented on a graphical display to the patient or a clinician.

At **108**, the ambulatory event is monitored with a patient tracking computer. The patient tracking computer receives the tracked location of the remote monitoring device from the LS system and monitors the device location over the course of the ambulatory event. The patient tracking computer may apply one or more algorithms derived from historical patient location information to calculate a distance traveled between location beacons over the course of the ambulatory event. In some embodiments, monitoring the ambulatory event includes determining a start of an ambulatory event and an end of an ambulatory event and monitoring the device location during the ambulatory event.

Next, at **110**, the patient tracking computer derives ambulatory event data from the tracked locations across the ambulatory event. As noted above, the ambulatory event data may include a variety of data, including: a distance traveled during the ambulatory event, a duration of the ambulatory event, and an average speed across the ambulatory event; however, these are not intended to be limiting on the types of ambulatory event data that may be derived by the patient tracking computer at **110**.

At **112**, the ambulatory event data derived at **110** is presented to a patient or clinician. The presentation of the ambulatory event data at **112** may be performed by a graphical display and may be presented in the form of a GUI or may alternatively be presented to the patient or clinician in a textual format as sent in e-mail or SMS communications.

In an alternative embodiment, while the remote monitoring device location is tracked at **104**, the remote monitoring device is also measuring a physiological value from the patient at **114**. The remote monitoring device transmits the measured physiological value to the patient tracking computer. In one embodiment, the LS system uses the transmission signal of the transmitted physiological value from the remote monitoring device in order to triangulate and track the remote monitoring device location at **104**.

After the physiological value has been measured and transmitted to the patient tracking computer, the patient tracking computer at **116** presents the ambulatory event data and the physiological value in a comparative format. As noted above with respect to **112**, the presentation of the ambulatory event data and the physiological value in a comparative format may be performed by a graphical display using a GUI or textual based communication.

As noted above, the comparative presentation of ambulatory event data and physiological values may relate a change in physiological value over the progress or course of the ambulatory event. In one non-limiting example, at **116**, the patient is presented with a plurality of SpO₂ values measured during the course of an ambulatory event. The SpO₂ values are presented in relation to the progress of the patient in the ambulatory event such as determined by distance traveled or ambulatory event duration.

This written description uses examples to disclose the invention, including the best mode, and also to enable any person skilled in the art to make and use the invention. The patentable scope of the invention is defined by the claims, and may include other examples that occur to those skilled in the art. Such other examples are intended to be within the scope of the claims if they have structural elements that do not differ from the literal language of the claims, or if they include equivalent structural elements with insubstantial differences from the literal languages of the claims.

We claim:

1. A system for telemetrically monitoring a patient, the system comprising:

a remote monitoring device associated with the patient, the remote monitoring device obtains a physiological value from the patient and broadcasts the physiological value; a location services (LS) system that tracks a plurality of locations of the remote monitoring device; and

a patient tracking computer communicatively connected to the remote monitoring device and the LS system, the patient tracking computer receives the physiological value and the plurality of locations of the remote monitoring device and executes computer readable code embodying an algorithm to calculate a distance traveled by the patient and a duration of patient ambulation to travel the calculated distance from the tracked plurality of locations received from the LS system, wherein the patient tracking computer applies an algorithm that identifies a plurality of possible paths between a first location of the plurality of locations of the remote monitoring device and a second location of the remote monitoring device, and calculates a probability that the remote monitoring device traveled a possible path associated with each of the plurality of possible paths, to calculate the distance traveled by the patient.

2. The system of claim 1, further comprising a global positioning system (GPS) within the remote monitoring device, wherein the GPS determines the plurality of locations of the remote monitoring device and the remote monitoring device broadcasts each of the plurality of locations determined by the GPS to the LS system.

3. The system of claim 1, further comprising at least two telemetry receivers that receive the physiological value broadcast by the remote monitoring device, wherein the LS system determines the plurality of locations of the remote monitoring device by triangulating the broadcast physiological value.

4. The system of claim 1, wherein the patient tracking computer further executes computer readable code that causes the patient tracking computer to monitor an ambulatory event prescribed by a clinician, the ambulatory event being defined in the computer readable code by a predetermined distance and a predetermined duration.

5. The system of claim 4, wherein the patient tracking computer further monitors an elapsed time for the ambulatory event.

6. The system of claim 5, further comprising a graphical display communicatively connected to the patient tracking computer, the graphical display presents the physiological value, the distance of the ambulatory event, and the elapsed time of the ambulatory event.

7. The system of claim 4, wherein the patient tracking computer executes computer readable code such that the computer identifies the ambulatory event within the plurality of locations of the remote monitoring device received by the patient tracking computer.

8. The system of claim 7, wherein the patient tracking computer executes computer readable code such that the calculated distance and calculated duration are a calculated distance of the ambulatory event and a calculated duration of the ambulatory event.

9. The system of claim 8, further comprising a graphical display communicatively connected to the patient tracking computer, the graphical display presents predetermined distance and predetermined duration in comparison to the calculated distance and the calculated duration.

10. The system of claim 1, wherein the algorithm applied by the patient tracking computer is derived from analysis of historical patient location information.

11. The system of claim 10, wherein the algorithm is derived using an advanced neural network (ANN).

12. The system of claim 1 wherein the patient tracking computer calculates the distance traveled by the patient as an average of distances of each of the plurality of possible paths weighted by the probability associated with each of the possible paths.

13. The system of claim 1 wherein the patient tracking computer calculates the distance traveled by the patient at a distance of a selected path of the plurality of possible paths having a highest probability associated with the path.

14. The system of claim 1 wherein the patient tracking computer further calculates an average speed from the duration of patient ambulation and the calculated distance traveled by the patient.

15. The system of claim 1 wherein the patient tracking computer further correlates the physiological value to the duration of patient ambulation and the calculated distance traveled by the patient.

16. A system for telemetrically monitoring a patient, the system comprising:

a remote monitoring device associated with the patient, the remote monitoring device obtains physiological values from the patient and broadcasts the physiological values;

a location service (LS) system that tracks a plurality of locations of the remote monitoring device; and

a patient tracking computer connected to the remote monitoring device and the LS system, the patient tracking computer receives the physiological values and the tracked plurality of locations of the remote monitoring device, and executes computer readable code that causes the patient tracking computer to determine an ambulatory event with a start and an end within the received plurality of locations, calculate a distance traveled by the patient during the ambulatory event, and calculate a duration for the ambulatory event, wherein the patient tracking computer applies an algorithm that identifies a plurality of possible paths between a first location of the plurality of locations and a second location of the plurality of locations of the remote monitoring device and calculates a probability associated with each of the possible paths in calculating the distance traveled by the patient during the ambulatory event.

17. The system of claim 16 wherein the patient tracking computer receives a prescribed route and the patient tracking computer determines the ambulatory event start and end based upon the prescribed route.

18. The system of claim 17, wherein the prescribed route comprises a plurality of locations tracked by the LS system.

19. The system of claim 18, wherein the patient tracking computer executes computer readable code that causes the patient tracking computer to calculate at least one correlation between the physiological values and at least one of the ambulatory event, distance traveled, and duration, and stores the calculated at least one correlation in a patient electronic medical record.

20. The system of claim 16 wherein the patient tracking computer calculates the distance traveled by the patient during the ambulatory event as a distance of a selected path of the plurality of possible paths having a highest probability associated with the path.

21. the system of claim 16 wherein the patient tracking computer calculates the distance traveled by the patient during the ambulatory event as an average of distances of each of the plurality of possible paths weighted by the probability associated with each of the possible paths.

22. A system for telemetrically monitoring a patient, the system comprising:

a remote monitoring device associated with the patient, the remote monitoring device obtains physiological values from the patient and broadcasts the physiological values;

a location service (LS) system that tracks a plurality of locations of the remote monitoring device; and

a patient tracking computer connected to the remote monitoring device and the LS system, the patient tracking computer receives the physiological values and the tracked plurality of locations of the remote monitoring device, and executes computer readable code that causes the patient tracking computer to determine an ambulatory event with an event start and an event end within the received tracked plurality of location, the patient tracking computer identifies a plurality of possible paths between a first location and a second location between the event start and the event end and identifies a probability associated with each of the plurality of possible paths, the patient tracking computer calculates a distance traveled by the patient during the ambulatory event in part based upon a distance of each of the identified possible paths and probabilities associated with possible paths, and calculates a duration for the ambulatory event between the determined event start and event end.

23. The system of claim 22 where the plurality of possible paths and probability associated with each of the plurality of possible paths are identified from historical patient ambulation data, and wherein the patient tracking computer calculates a distance between the first location and the second location within the ambulatory event by selecting a distance of a path of the plurality of paths associated with a highest probability.

* * * * *

专利名称(译)	使用定位技术来帮助患者恢复的系统和方法		
公开(公告)号	US9104788	公开(公告)日	2015-08-11
申请号	US12/849557	申请日	2010-08-03
[标]申请(专利权)人(译)	通用电气公司		
申请(专利权)人(译)	通用电气公司		
当前申请(专利权)人(译)	通用电气公司		
[标]发明人	FRIEDMAN BRUCE A GRUBIS MATTHEW NANTZ BRIAN W DAVIS CARL C		
发明人	FRIEDMAN, BRUCE A. GRUBIS, MATTHEW NANTZ, BRIAN W. DAVIS, CARL C.		
IPC分类号	A61B5/00 G01S19/01 G01S17/08 A61B5/11 G06F19/00 G01S5/00 G07C1/10 G01S17/00 G01S13/46 G07C9/00		
CPC分类号	G06F19/327 G06F19/34 G01S19/01 A61B5/112 A61B5/0002 G06F19/345 G01S17/08 A61B5/1112 A61B5/113 G06F19/3418 G07C1/10 G07C9/00111 G01S2013/468 G07C9/28 G16H10/60 G16H40/20 G16H40/67 G16H50/20 A61B5/72 A61B5/742 A61B2505/09		
审查员(译)	THOMSON, WILLIAM		
助理审查员(译)	ARCHER, MARIE		
其他公开文献	US20120035427A1		
外部链接	Espacenet USPTO		

摘要(译)

用于遥测患者的系统包括与患者相关联的远程监控设备。位置服务系统跟踪远程监控设备的位置。患者跟踪计算机从跟踪的位置计算患者走动的距离和持续时间。监视移动患者的方法监视远程监视设备的位置并从监视的位置导出移动事件数据。

