



US008311613B2

(12) **United States Patent**  
**Danehorn**

(10) **Patent No.:** **US 8,311,613 B2**  
(45) **Date of Patent:** **Nov. 13, 2012**

(54) **ELECTRODE CATHETER POSITIONING SYSTEM**

(75) Inventor: **Kenneth Danehorn**, Vaxholm (SE)

(73) Assignee: **Siemens Aktiengesellschaft**, Munich (DE)

(\* ) Notice: Subject to any disclaimer, the term of this patent is extended or adjusted under 35 U.S.C. 154(b) by 1513 days.

(21) Appl. No.: **11/820,697**

(22) Filed: **Jun. 20, 2007**

(65) **Prior Publication Data**

US 2008/0319297 A1 Dec. 25, 2008

(51) **Int. Cl.**  
**A61B 5/00** (2006.01)

(52) **U.S. Cl.** ..... **600/424; 600/393**

(58) **Field of Classification Search** ..... **600/372, 600/373, 393, 424**

See application file for complete search history.

(56) **References Cited**

**U.S. PATENT DOCUMENTS**

5,391,199 A 2/1995 Ben-Haim  
5,398,691 A 3/1995 Martin et al.  
5,697,377 A 12/1997 Wittkampf  
5,830,145 A 11/1998 Tenhoff

5,840,031 A 11/1998 Crowley  
5,876,345 A 3/1999 Eaton et al.  
5,879,305 A 3/1999 Yock et al.  
5,944,022 A 8/1999 Nardella et al.  
6,050,267 A 4/2000 Nardella et al.  
6,171,303 B1 1/2001 Ben-Haim et al.  
6,216,027 B1 4/2001 Willis et al.  
6,230,042 B1 5/2001 Slettenmark  
6,259,941 B1 7/2001 Chia et al.  
6,490,474 B1 12/2002 Willis et al.  
6,612,992 B1 9/2003 Hossack et al.  
6,807,439 B2 10/2004 Edwards et al.  
7,019,650 B2 3/2006 Volpi et al.  
7,263,397 B2\* 8/2007 Hauck et al. .... 600/374  
7,756,576 B2\* 7/2010 Levin ..... 600/547  
2007/0066889 A1\* 3/2007 Boese et al. .... 600/424  
2007/0083247 A1\* 4/2007 Wyeth et al. .... 607/99

\* cited by examiner

*Primary Examiner* — Jonathan Cwern

(74) *Attorney, Agent, or Firm* — Lempia Summerfield Katz LLC

(57) **ABSTRACT**

A system for determining a position of a catheter is provided. An electrode is on a catheter. A plurality of reference electrodes are provided. Each of the plurality of reference electrodes are configured to transmit or receive a signal to or from the electrode, respectively. A processor is operable to determine a position of the catheter as a function of an electrical characteristic based on the signals. The plurality of reference electrodes are not positioned on or in a body surface along three mutually orthogonal axes.

**13 Claims, 4 Drawing Sheets**

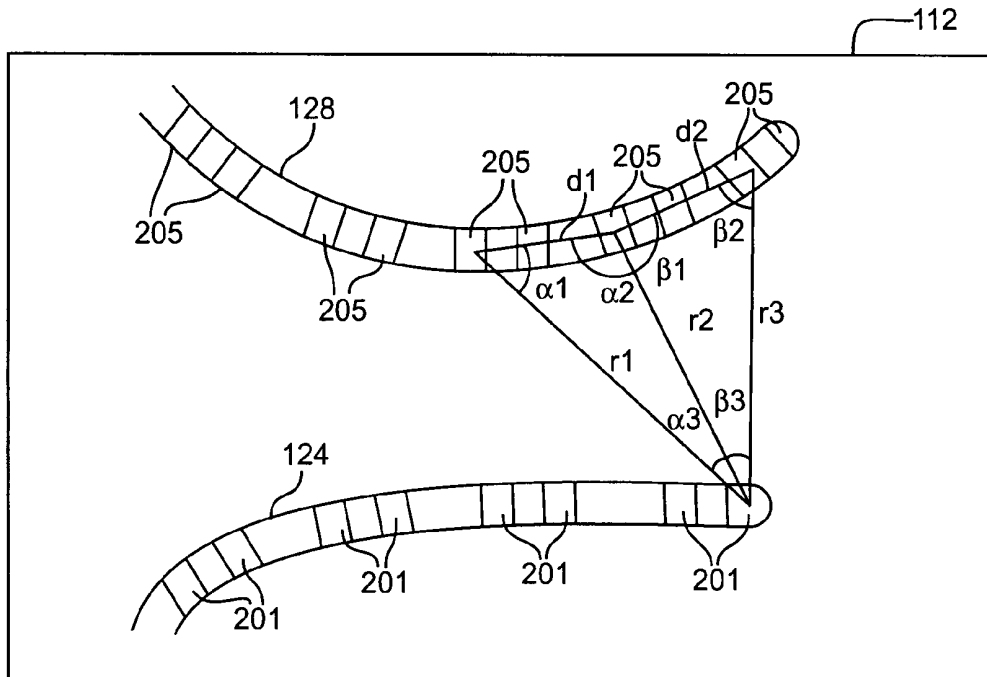

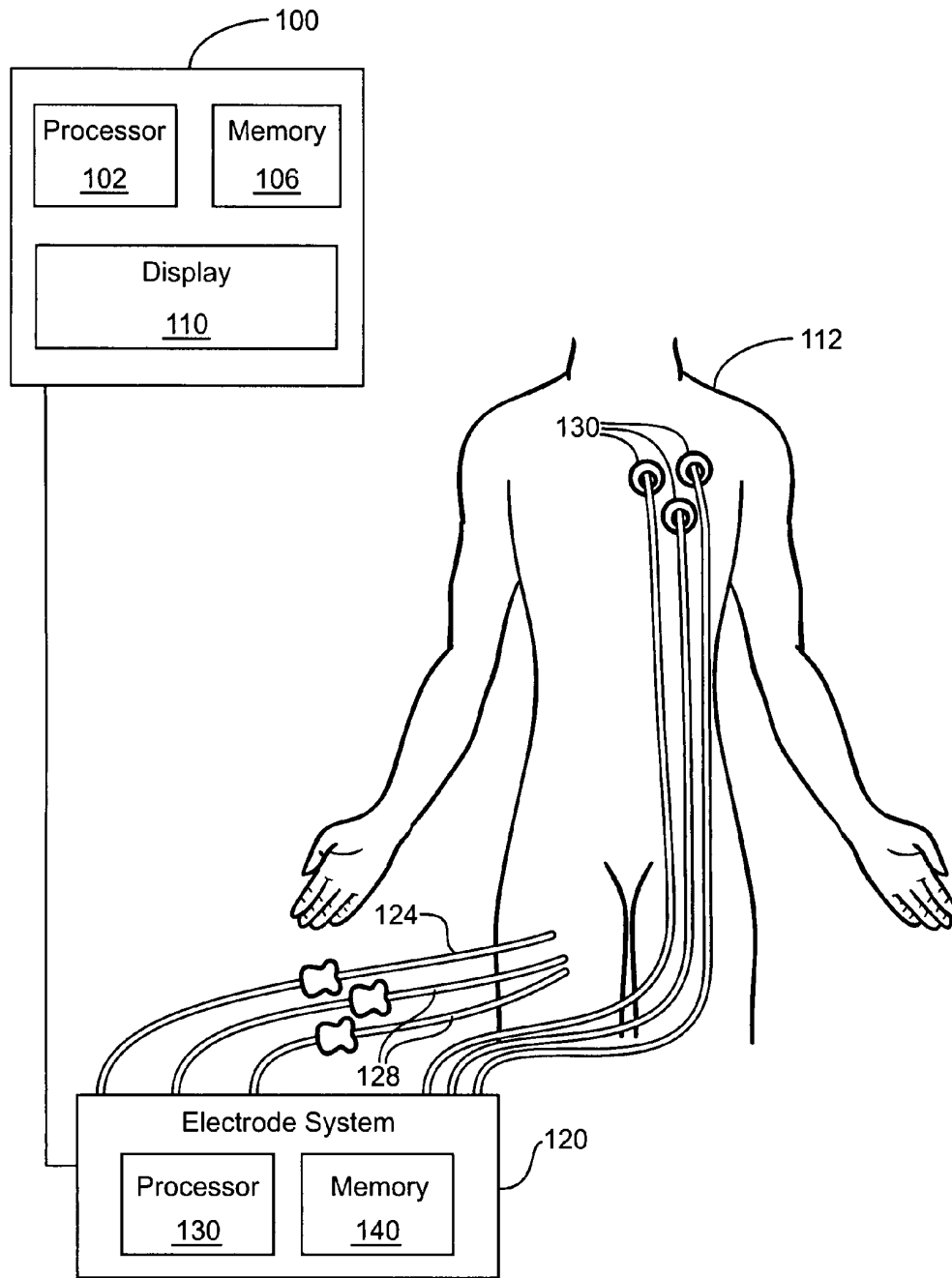

Fig.1

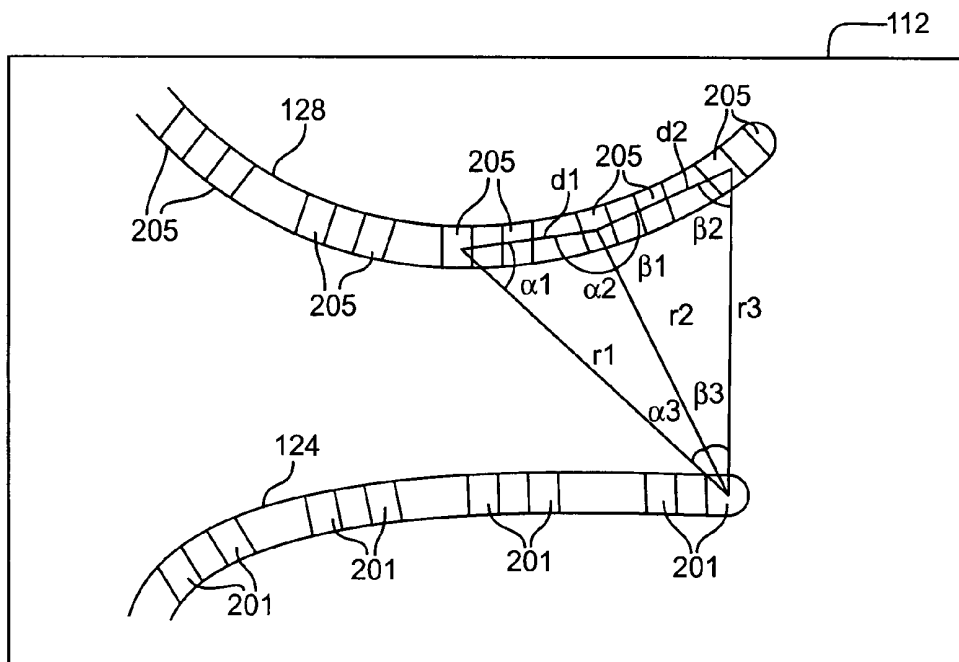

Fig. 2

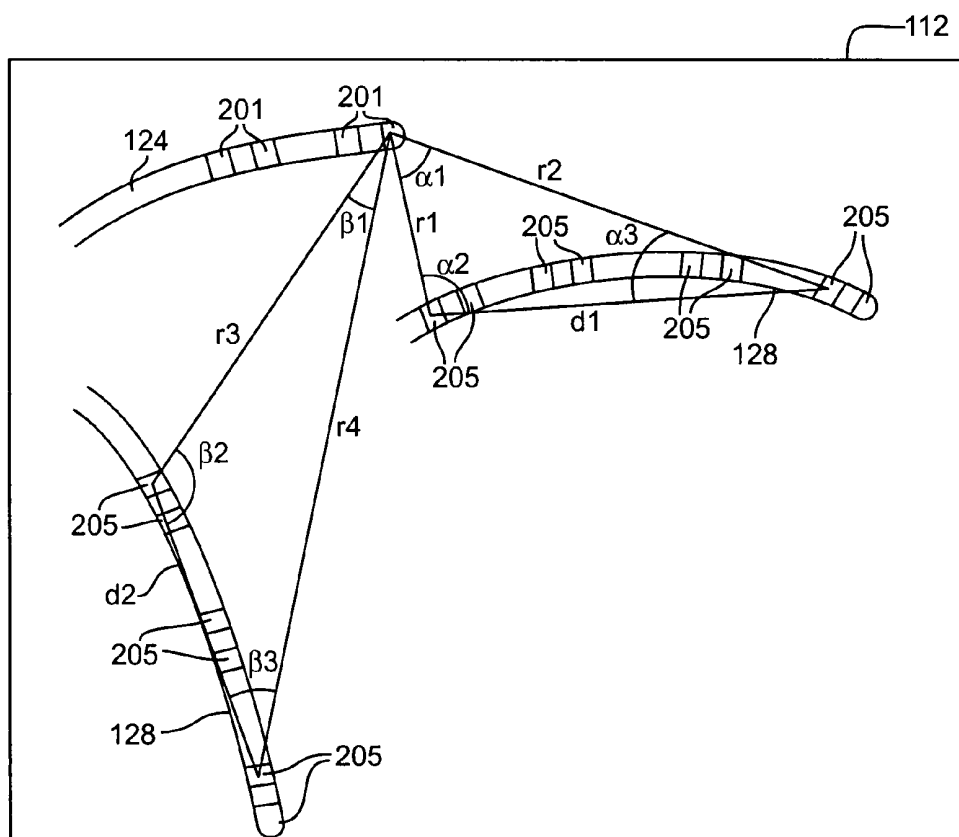

Fig. 3

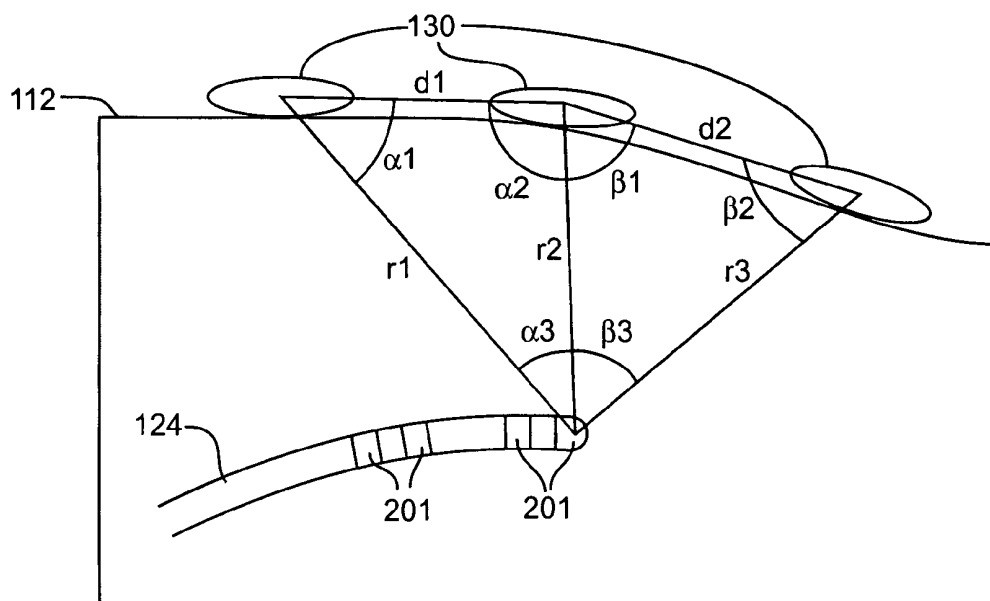

Fig. 4

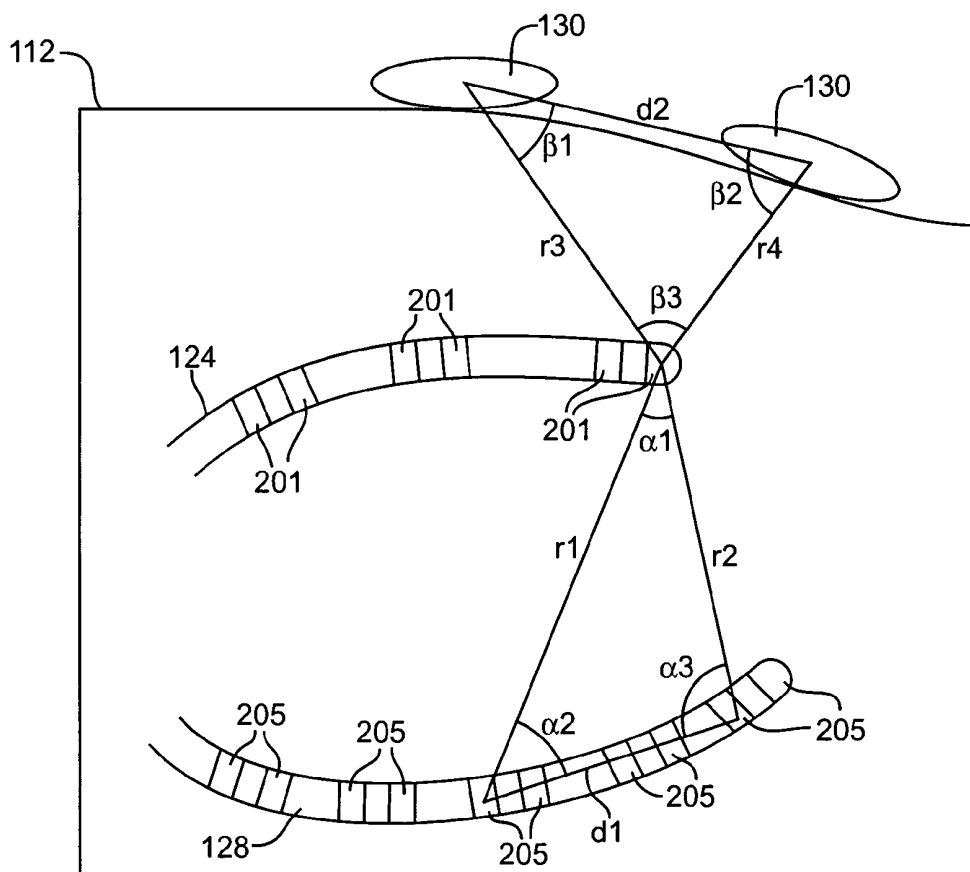

Fig. 5

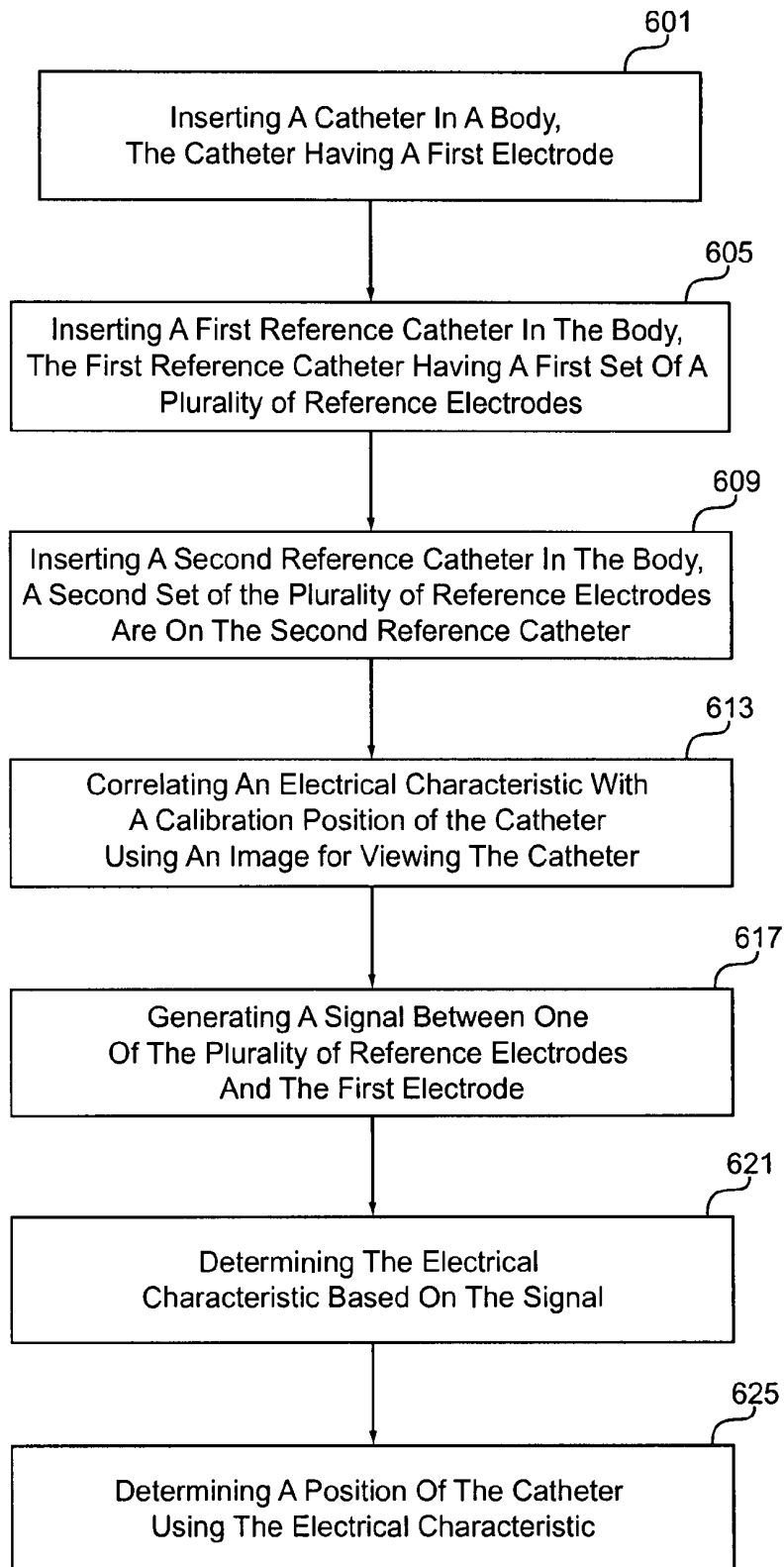

Fig. 6

## ELECTRODE CATHETER POSITIONING SYSTEM

### BACKGROUND

The present embodiments relate to medical catheters. In particular, accurate positioning of a catheter inside a body using electrodes is provided.

Catheters are used for several types of medical procedures. For example, catheters are used to measure electrical activity, capture image data, and/or apply stents within a body. Additionally, catheters are used for ablation therapy, especially for the treatment of heart disease. The positioning of such catheters during treatment or measurement procedures is of great interest to medical professionals due to the limited area to navigate within or due to navigation near sensitive internal organs.

A variety of medical imaging systems are used to assist medical professionals with maneuvering and positioning catheters within a body. For example, ultrasound, computed tomography ("CT"), and X-ray systems are used to generate images of the catheter within the body during treatment or measurement procedures. However, minimizing the use of imaging systems during the catheter procedures may be desired to reduce cost as well as minimize exposure, such as X-rays, to the patient.

Catheter positioning systems may not utilize external medical imaging systems during the entire treatment or measurement procedures. Specialized catheters having coils or transducers or systems utilizing patches positioned along three mutually orthogonal axes on a body surface have been proposed. However, the use of such systems may increase cost as well as complexity.

### BRIEF SUMMARY

By way of introduction, the preferred embodiments described below include catheters including electrodes, body surface electrodes, and methods of positioning a catheter within a body. A plurality of reference electrodes are provided. A catheter having an electrode is operable to communicate with the reference electrodes, and a position of the catheter is determined based on the communication between the electrodes.

According to a first aspect, a system for determining a position of a catheter is provided. An electrode is on a catheter. A plurality of reference electrodes are provided. Each of the plurality of reference electrodes are configured to transmit or receive a signal to or from the electrode, respectively. A processor is operable to determine a position of the catheter as a function of an electrical characteristic based on the signals. The plurality of reference electrodes are not positioned on or in a body surface along three mutually orthogonal axes.

According to a second aspect, a system for determining a position of a catheter is provided. First and second electrodes are on a catheter. A plurality of reference electrodes are provided. Each of the plurality of reference electrodes are configured to transmit or receive a signal to or from the first and second electrodes, respectively. A processor is operable to determine a position of the catheter as a function of a voltage potential between the second electrode and one of the plurality of reference electrodes when the first electrode and another one of the plurality of reference electrodes are transmitting and receiving the signal, respectively.

According to a third aspect, a method for determining a position of a catheter is provided. A catheter is inserted in a body. The catheter has a first electrode. A first reference

catheter is inserted in the body. The first reference catheter has a first set of a plurality of reference electrodes. A signal is generated between one of the plurality of reference electrodes and the first electrode. An electrical characteristic is determined based on the signal. A position of the catheter is determined using the electrical characteristic.

The present invention is defined by the following claims, and nothing in this section should be taken as a limitation on those claims. Further aspects and advantages of the invention are discussed below in conjunction with the preferred embodiments.

### BRIEF DESCRIPTION OF THE DRAWINGS

The components and the figures are not necessarily to scale, emphasis instead being placed upon illustrating the principles of the invention. Moreover, in the figures, like reference numerals designate corresponding parts throughout the different views.

FIG. 1 is a general diagram illustrating one embodiment of a system for determining a position of a catheter;

FIG. 2 is a magnified view of one embodiment of the system for determining a position of a catheter of FIG. 1;

FIG. 3 is a magnified view of a first alternate embodiment of the system for determining a position of a catheter of FIG. 1;

FIG. 4 is a magnified view of a second alternate embodiment of the system for determining a position of a catheter of FIG. 1;

FIG. 5 is a magnified view of a third alternate embodiment of the system for determining a position of a catheter of FIG. 1; and

FIG. 6 is a flowchart illustrating one embodiment of a method for determining a position of a catheter.

### DETAILED DESCRIPTION OF THE DRAWINGS AND PRESENTLY PREFERRED EMBODIMENTS

A position of a treatment and/or measurement catheter having electrodes can be determined in a two step approach. Firstly, relative distances between reference body surface electrodes or electrodes on a reference catheter and the electrodes on the treatment and/or measurement catheter are calibrated by image segmentation using X-ray images. Secondly, distances between the treatment and/or measurement catheter and the reference catheter or reference body surface electrodes are measured by estimating the impedance of blood between the electrodes or measuring the voltage potential between non-transmitting or non-receiving electrodes. Several reference catheters and/or reference body surface electrodes can be used to obtain more accurate positioning information. The accurate position of electrodes in the measurement and/or treatment catheter is measured either in a sequential manner or using signals with different frequencies, and the accurate position is derived using triangulation methods. Also, heart beat motion and breathing motion can be compensated for by various triggering techniques. Coordinate position data gathered by the system may be used in conjunction with an image volume data set to enable a three dimensional ("3D") animation of the measurement and/or treatment catheter within a body.

FIG. 1 is a general diagram illustrating one embodiment of a system for determining a position of a catheter **124**. The system includes, but is not limited to an imaging system **100**, an electrode system **120**, a catheter **124**, reference catheters

128, and reference body surface electrodes 130. Fewer or more components may be utilized.

The imaging system 100 is a X-ray system, CT system, ultrasound system, or any known or future medical imaging system. For example, the imaging system 100 is a X-ray system operable to generate X-ray images of a chest region of a patient 112. The imaging system 100 includes a processor 102, a memory 106, a display 110, and/or any known or future electronic and/or audio/visual hardware used for medical imaging.

The processor 102 is in communication with the memory 106 and the display 110. The processor 102 is a main processor, such as a microprocessor, or a plurality of processors operable to communicate with electronics of the imaging system 100. The memory 106 is any known or future storage device. For example, the memory 106 is a non-volatile and/or volatile memory, such as a Random Access Memory "RAM" (electronic), a Read-Only Memory "ROM" (electronic), or an Erasable Programmable Read-Only Memory (EPROM or Flash memory). The display 110 is any mechanical and/or electronic display positioned for accessible viewing by a doctor or medical professional. For example, the display 110 is a liquid crystal display, ("LCD"), printer, or cathode ray tube ("CRT") monitor. The display 110 is operable to show 2D, 3D, and/or four dimensional ("4D") images (i.e., the fourth dimension is time, and, therefore, 4D images are a sequence of images that show an object over a time period).

The imaging system 100 is operable to process or run any variety of known or future medical imaging software protocols and/or applications. For example, the imaging system 100 includes or is operable to load programs or applications for determining calibration position data for the catheter 124 within the patient 112 as well as for processing image data and rendering 2D, 3D, and/or 4D images.

The electrode system 120 is in communication with the imaging system 100. The electrode system 120 includes, but is not limited to, a processor 130 and a memory 140. The processor 130 is in communication with the processor 102. The processor 130 is a main processor, such as a microprocessor, or a plurality of processors operable to communicate with electronics of the electrode system 120. The memory 140 is any known or future storage device. For example, the memory 140 is a non-volatile and/or volatile memory, such as a Random Access Memory "RAM" (electronic), a Read-Only Memory "ROM" (electronic), or an Erasable Programmable Read-Only Memory (EPROM or Flash memory).

The electrode system 120 is operable to receive calibration data from the imaging system 100 and to process electrical signals from the catheter 124, the reference catheters 128, and/or the body surface electrodes 130 to determine an internal position of the catheter 124. Additionally, the electrode system 120 may transmit the catheter 124 position data to the imaging system 100 to display a 3D animation or virtual image of the catheter inside the patient 112.

Alternatively, the imaging system 100 and the electrode system 120 are one system. Or, the imaging system 100 and the electrode system 120 are separate systems that are not in communication with each other. In this case, calibration data acquired by the imaging system 100 is transferred or entered into the electrode system 120, and position data of the catheter 124 determined by the electrode system 120 is used to display an image of the catheter 124 on a display connected with the electrode system 120, the imaging system 100, or another imaging system. Any combination of features and components of the imaging system 100 and the electrode system 120 may be combined or separated in one or more systems.

The patient 112 is any living or nonliving object. For example, the patient 112 is an animal or human being. The catheter 124 and the catheters 128 are inserted through any part or region of the patient 112 to be positioned in or by any anatomical feature for treatment and/or measurement purposes. For example, to measure heart activity or to perform ablation therapy on the heart of the patient 112, the catheter 124 and the reference catheters 128 are inserted into a limb, such as an arm or leg, of the patient 112 to enter into a vein or artery that leads to the heart. For example, the catheter 124 is inserted into a femoral vein of the patient 120. The reference catheters 128 may be inserted into the same vein or other veins. Alternatively, the catheter 124 and the reference catheters 128 are inserted in the throat, chest, abdomen, any opening or orifice, or any other part of the patient 112. The body surface electrodes 130 may be attached to any part of the patient 112's body in conjunction with the catheter 124 and the reference catheters 128. For example, the body surface electrodes 130 are attached on the chest of the patient 112. The body surface electrodes 130 may be positioned at specific locations, such as at a particular distance and direction from the naval and/or nipples.

Referring to FIG. 2, the catheter 124 is a treatment catheter used for ablation therapy or applying stents, a measurement catheter used for measuring electrical or other physiological activity, an imaging catheter, such as an ultrasonic catheter, and/or any other known or future catheter. For example, the catheter 124 includes a body or lumen having a longitudinal axis and a circumference. The body or lumen is a flexible shaft that is made of a plastic, a polymer, and/or any known or future flexible material. The lumen is sized for insertion into the circulatory system, such as less than about 5 mm in diameter. The body may include a flexible tip and/or guide wires. Also, the catheter 124 may include a handle and/or a steering mechanism.

Pairs of electrodes 201 are disposed on or in the body of the catheter 124. Alternatively, the electrodes 201 may be disposed in non-pair configurations. The electrodes 201 are disposed spaced apart from the distal end of the catheter 124 to any predetermined position along the length of the body of the catheter 124. The electrodes 201 form a continuous or non-continuous loop around the body of the catheter 124 allowing contact with blood or tissue within the patient 112. Alternatively, predetermined grooves may be set in the outer surface of the catheter 124 to receive the electrodes 201 so that the electrodes 201 are flush with the rest of the outer surface of the catheter 124. The electrodes 201 are made of any metal material or any known or future material operable to transmit and receive electrical signals. Alternatively, the electrodes 201 are made of a non-magnetic material that may be scanned with a magnetic resonance imaging ("MRI") system and yet still transmit and receive electrical signals. The electrodes 201 are connected with the electrode system 120. The electrodes 201 are also connected with a voltage or current generator, which may or may not be part of the electrode system 120. The generator is connected with all or some of the electrodes 201. For example, the generator is connected to one electrode 201 in each pair of the electrodes 201. The generator may be connected to one electrode 201 in the most distal pair, the most proximal pair, and a middle pair of electrodes 201.

The reference catheter 128 is a catheter for transmitting and receiving electrical signals. For example, the reference catheter 128 includes a body or lumen having a longitudinal axis and a circumference. The body or lumen is a flexible shaft that is made of a plastic, a polymer, and/or any known or future flexible material. For example, the body of the reference

catheter 128 has a curvilinear shape. Also, the reference catheter 128 may include a handle and/or a steering mechanism.

Electrodes 205 are disposed on the body of the reference catheter 128. The arrangement and type of the electrodes 205 are similar to or the same as the electrodes 201, as described above. Different arrangements and/or type may be used. The electrodes 205 are not positioned on or in the body surface of the patient 112 along three mutually orthogonal axes. The electrodes 205 are connected with the electrode system 120. The electrodes 205 are also connected with a voltage or current generator, which may or may not be part of the electrode system 120. The voltage or current generator may be the same generator used in conjunction with the catheter 124 or may be a separate generator. The respective generator is connected with all or some of the electrodes 205.

For example, the voltage or current generator for the catheter 124 generates an alternating current (“AC”) signal, such as a low current signal at about 10 kHz, and transmits the signal from one electrode 201, and the voltage or current generator for the reference catheter 128 generates a signal at substantially the same frequency with a phase shift of 180 degrees and transmits that signal from one electrode 205. By having a 180 degree phase shift, a current is created between the electrode 201 and the electrode 205. To insure that the current is floating from the electrode 201 and the electrode 205, these electrodes are controlled to have low impedance in relation to the other electrodes. This is accomplished by phase shifting two generators connected to the electrode 201 and the electrode 205, respectively. The phase shifting acts as a current pump where electrons are pumped from one electrode to another electrode. A current may be generated between any of the electrodes 201 and 205, respectively. This transmitting and receiving configuration between the electrodes 201 and 205 is time divided so that one frequency is used. Alternatively, the same voltage or signal generator is used for both the electrodes 201 and 205. Or, separate voltage or current generators are used for each or a group of electrodes 201 and 205 to allow for the use of different frequencies without sequentially transmitting or receiving signals between the electrodes 201 and 205.

Also, a direct current (“DC”) signal may be used between the electrodes 201 and 205. For example, DC generators connected with the catheter 124 and the reference catheter 128 may allocate specific sinking and sourcing timing configurations to allow for a DC current between a certain electrode 201 and a certain electrode 205.

A position of an electrode 201 is determined based on an electrical characteristic of the signal between the electrode 201 and a respective electrode 205. For example, an impedance of blood between the electrode 201 and the electrode 205 is calculated using any known or future mathematics or physics calculation or equation, such as Ohms’ law. The different impedances between electrodes relate to the distances between the same electrodes. For example, the impedance will increase as the distance between electrodes increases. A predetermined look-up table may be used to store distance values that correlate to different impedances. These values may be obtained by testing the patient 112 or other patients. Alternatively, the values may be obtained by testing random blood samples. The distances r1, r2, and r3 are determined based on the respective impedance using a transfer function or any other mathematical technique in conjunction with the look-up table. Because the relative positions of the electrodes 205 on the reference catheter 128 and the electrodes 201 on the catheter 124 are known, the distances d1 and d2 as well as the angles  $\alpha_1$ ,  $\alpha_2$ ,  $\alpha_3$ ,  $\beta_1$ ,  $\beta_2$ , and  $\beta_3$  can be determined. The relative distances and angles may be used in triangulation

formulas, trigonometric equations, and/or any other known or future mathematical techniques to derive a three point coordinate position of the electrode 201. Ultimately, the position of the catheter 124 is determined because the placement of the electrodes 201 on the catheter 124 is known. Positions may be determined for any number of electrodes 201 as well as any number of different catheters.

Alternatively, instead of calculating blood impedance, a voltage potential between a certain electrode 205 and a certain electrode 201 may be measured to determine the distance between the electrodes. For example, when one electrode 205 is transmitting or receiving a signal from one electrode 201, an electric field is generated due to the current flow. Therefore, a voltage potential, created by the electric field, may be measured between another electrode 205, such as an electrode adjacent to the transmitting or receiving electrode 205, and another electrode 201, such as an electrode adjacent to the transmitting or receiving electrode 201. The different voltage potentials between electrodes relate to the distances between the same electrodes. For example, the voltage measured will increase as the distance between electrodes increases. A predetermined look-up table may be used to store distance values that correlate to different voltage potentials. These values may be obtained by testing the patient 112 or other patients. Alternatively, the values may be obtained by testing random blood samples. The distances r1, r2, and r3 are determined based on the respective voltage potential using a transfer function or any other mathematical technique in conjunction with the look-up table. The distances d1 and d2 as well as the angles  $\alpha_1$ ,  $\alpha_2$ ,  $\alpha_3$ ,  $\beta_1$ ,  $\beta_2$ , and  $\beta_3$  can be determined by any technique described above.

The electrodes 201 and 205 are unlike magnetic coils that create an electromagnetic field to induce electric currents in adjacent coils. The amplitude of the electric current is proportional to the distance from the coil generating the field. Hence, the amplitude of the induced current is a measure of the distance. The angle of the coil in relation to the magnetic field is also of importance. When three perpendicular coils are positioned at the tip of a catheter, three electrical currents can be measured in which the geometric relation also gives information of catheter direction. However, using electrodes does not involve generating electromagnetic fields to induce electric currents in adjacent coils. An electric current is sent from one electrode to another to create a potential field through the blood pool and/or tissue between the electrodes where a continuous potential drop is created. The electric current is generated using phase shifting as described above. For example, the current is about 0.1 mA at 10 kHz. In this way, impedance and/or voltage potential relating to distance may be determined. Also, the electric current is continuously moving or changing as the catheter 124 is moving.

Also, the magnetic coil approach includes coils generating the field that need to be positioned at a known position either inside or outside the patient 112 as well as measurement coils that need to be integrated in the catheter. Therefore, specific catheters are used, unlike the electrode approach in which catheters with simple electrodes may be used. The position is determined without using electrodes external to the patient, but such electrodes may be used.

FIG. 3 is a magnified view of a first alternate embodiment of the system for determining a position of the catheter 124. In this embodiment, two reference catheters 128 are used. However, any number of reference catheters 128 may be used. More reference catheters 128 allow for more accurate position data. The reference catheters 128 can be positioned in any direction in the patient 112. For example, the reference catheters 128 are positioned at an angle to each other. Therefore,

the reference catheters 128 may be substantially straight. Alternatively, the reference catheters 128 are curvilinear in shape.

The reference catheters 128 share the same voltage or current generator or they each utilize a separate generator. As mentioned above, a position of the electrode 124 is determined based on the signals transmitted and received between the electrodes 201 and 205, respectively. Relative distances between the electrodes 201 and 205 are determined by blood impedance, voltage potential, and/or any other electrical characteristic. The distances  $r_1$ ,  $r_2$ ,  $r_3$ ,  $r_4$ ,  $d_1$  and  $d_2$  as well as the angles  $\alpha_1$ ,  $\alpha_2$ ,  $\alpha_3$ ,  $\beta_1$ ,  $\beta_2$ , and  $\beta_3$  can be determined by any technique described above.

FIG. 4 is a magnified view of a second alternate embodiment of the system for determining a position of the catheter 124. In this case, the body surface electrodes 130 are used as reference electrodes instead of the reference catheter 128. The body surface electrodes 130 are placed on any part of the patient 112's body. For example, the body surface electrodes 130 are not positioned on or in the body surface along three mutually orthogonal axes. Instead, the electrodes 130 may be positioned based on body location or more random locations on the patient. The body surface electrodes 130 are made of any metal material or any known or future material operable to transmit and receive electrical signals. For example, the body surface electrodes 130 are electrocardiogram ("ECG") electrodes. Alternatively, the body surface electrodes 130 are made of a non-magnetic material that may be scanned with a magnetic resonance imaging ("MRI") system and yet still transmit and receive electrical signals. For example, titanium or carbon fiber material may be used. Also, the body surface electrodes 130 may be needle or pin electrodes that can be inserted in the body surface of the patient 112. The body surface electrodes 130 are connected with the electrode system 120 or a separate or included ECG system. The electrodes 201 are also connected with a voltage or current generator, which may or may not be part of the electrode system 120 or the ECG system. The generator is connected with all or some of the electrodes 130.

The operation of the body surface electrodes 130 and the electrodes 201 configuration is substantially similar to the reference catheter 128 and the catheter 124 configuration, as described above. The position of the electrode 201 is determined based on the signals transmitted and received between the electrodes 201 and 130, respectively. Relative distances between the electrodes 201 and 130 are determined by impedance, voltage potential, and/or any other electrical characteristic. In this case, in addition to blood impedance, an impedance of other tissue, such as lung tissue as well as other thoracic impedance, is determined. A predetermined look-up table may be used to store distance values that correlate to combinations of different impedances. These values may be obtained by testing the patient 112 or other patients. Alternatively, the values may be obtained by testing random blood and other tissue samples. The distances  $r_1$ ,  $r_2$ ,  $r_3$ ,  $d_1$  and  $d_2$  as well as the angles  $\alpha_1$ ,  $\alpha_2$ ,  $\alpha_3$ ,  $\beta_1$ ,  $\beta_2$ , and  $\beta_3$  can be determined by any technique described above.

The impedance between the catheter electrodes and the body surface electrodes may vary due to motion when the patient 112 is breathing, inflation of air in the lungs, and possibly varying contact impedance of each of the body surface electrodes. To compensate for this, breathing activity may be measured and used in a feed forward compensation. Alternatively, filters to remove the low frequency disturbing variation may be utilized.

Any number and combinations of the body surface electrodes 130 and the reference catheters 128 may be utilized to

determine the position of the catheter 124. For example, referring to FIG. 5, one reference catheter 128 is used in conjunction with two body surface electrodes 130 to determine the position of the catheter 124. However, any number of reference catheters 128 and body surface electrodes 130 may be used. For example, at least two reference catheters 128 and at least six body surface electrodes 130 are utilized. More reference catheters 128 and body surface electrodes 130 that are used allow for more accurate position data.

The reference catheter 128 and the body surface electrodes 130 share the same voltage or current generator or they each utilize a separate generator. As mentioned above, a position of the electrode 124 is determined based on the signals transmitted and received between the electrodes 201, 205, and 130, respectively. Relative distances between the electrodes 201, 205, and 130 are determined by impedance, such as thoracic and blood impedance, voltage potential, and/or any other electrical characteristic. The distances  $r_1$ ,  $r_2$ ,  $r_3$ ,  $r_4$ ,  $d_1$  and  $d_2$  as well as the angles  $\alpha_1$ ,  $\alpha_2$ ,  $\alpha_3$ ,  $\beta_1$ ,  $\beta_2$ , and  $\beta_3$  can be determined by any technique described above.

In any of the embodiments described above, more accurate position data is obtained, especially for non-homogenous blood and other tissue characteristics between different patients 112 or in the same patient 112, by calibrating the catheter 124 with the reference catheters 128 and/or the body surface electrodes 130. Calibration involves generating images, such as X-ray image segmentations, while transmitting and receiving electrical signals between the electrodes 205, 130, and 201. The X-ray images are taken when the catheter 124 is positioned in different locations and the reference catheters 128 and/or the body surface electrodes 130 remain in the same position. A correlation between the actual distances between electrodes determined by the images and the distances estimated by the electrode system 120 may be obtained. The correlations are stored in the memory 140 and/or 106 and are relied on to obtain accurate position data of the catheter 124 during medical procedures. The correlations may be used in conjunction with the predetermined look up tables, described above, to adjust the distance values appropriately. For example, an adjusted offset based on a correlation is added to an output of a predetermined look up table.

Heart beat and breathing patterns can be compensated for by using a variety of techniques. For example, position data may be determined once during every heart beat or breathing cycle by triggering the electrode system 120 with the respective physiological cycle. Any other known or future physiological compensation technique may be utilized.

FIG. 6 is a flowchart illustrating one embodiment of a method for determining a position of the catheter 124. In act 601, a catheter is inserted in a body, such as the body of the patient 112. The catheter is any treatment or measurement catheter, such as the catheter 124, including electrodes on the body of the catheter. Any known or future methods of inserting the catheter may be utilized. For example, an incision is made in the patient 112, such as in the arm or the leg, and the catheter 124 is inserted into the incision by a doctor, medical professional, and/or machine. Alternatively, a needle or puncturing device may be inserted into the patient 112, and the catheter 124 follows the puncturing device. Or, the catheter 124 is inserted into any orifice or opening of the patient 112. Any known or future lubricant or mechanical, electrical, and/or catheter guide may be used in assisting with inserting the catheter 124 into the patient 112.

In act 605, a first reference catheter is inserted in the body. The first reference catheter is any catheter including a first set of a plurality of reference electrodes, such as the reference catheter 128. Any of the methods of inserting a catheter in a

body described above may be utilized to insert the first reference catheter. Alternatively, body surface electrodes, such as the electrodes 130, are attached on the body surface of the patient 130 instead of inserting the first reference catheter. For example, the electrodes 130 are not positioned on or in the body surface of the patient 112 along three mutually orthogonal axes.

In act 609, a second reference catheter is inserted in the body. The second reference catheter is any catheter including a second set of the plurality of reference electrodes, such as another reference catheter 128. Any of the methods of inserting a catheter in a body described above may be utilized to insert the second reference catheter. Alternatively, body surface electrodes, such as the electrodes 130, are attached on the body surface of the patient 130 instead of inserting the second reference catheter. For example, the electrodes 130 are not positioned on or in the body surface of the patient 112 along three mutually orthogonal axes.

In act 613, a calibration procedure is performed. For example, once the first reference catheter, the second reference catheter, and/or the body surface electrodes are positioned in or on the patient 112, they remain at their respective positions. The catheter 124 is then moved to one region within the body, and the electrodes 201 and the electrodes 205 and/or 130 transmit and receive electrical signals between each other, respectively.

Voltage or current generators connected with the electrodes generate a current between two specific electrodes. For example, a generator is connected with the electrodes 201 and one or more generators are connected with the reference electrodes 205 and/or 130. The generators may be connected with all or some of the respective electrodes. The generators are phase shifted 180 degrees to allow for a path of least resistance between any two electrodes. The electrical signals between the electrodes may be AC or DC signals. When using AC signals, sequential transmission of the signals between electrodes is performed to allow for the use of a substantially same frequency. Alternatively, more generators may be used to transmit and receive electrical signals between electrodes at different frequencies.

While electrical signals are being generated between the electrodes when the catheter 124 is in the first position, images, such as X-ray images, are taken. The actual distances between the electrodes 201 and the reference electrodes 205 and/or 130 are determined from the images, and the distances are correlated with estimated distance values. The estimated distance values directly relate to impedance values or voltage potential values determined based on the electrical signals. For example, a medical professional obtains actual distance data from the images and compares the actual distance data with the estimated distance data determined by the electrode system 120. Compensation values based on the comparison are manually entered into the electrode system 120 for calibration purposes. Alternatively, the imaging system 100 determines the actual distance values based on the images, and the actual distance data is transmitted or transferred to the electrode system 120. Then the electrode system 120 calculates the respective compensation factors for calibration.

The catheter 124 is then moved to a second position. Electrical signals are transmitted between the electrodes 201 and 205 and/or 130 while images are taken for the new position. The same methods of calibration are performed for the second position as was performed for the first position. More positions the catheter 124 allow for a better calibration. Physical differences between different patients 112 or within the same patient 112 may be compensated.

After calibration, capturing images during medical procedures using the catheter 124 may not be needed. For example, X-ray exposure to the patient 112 is minimized. Also, during treatment or measurement medical procedures, the catheter 124 is moved to a variety of positions by a medical professional, and the reference catheters 128 and/or body surface electrodes 130 remain substantially at the same position. The position of the catheter 124 during the procedures is determined.

For example, in act 617, an electrical signal is generated between at least one of the plurality of reference electrodes 205 and/or 130 and at least one electrode 201. The generation and characteristic of the signal is described above.

In act 621, an electrical characteristic is determined based on the signal. The electrical characteristic is a blood impedance, any other tissue impedance, such as impedance of lung tissue as well as other thoracic impedances, a voltage potential, and or any other electrical characteristic.

For example, when a current is flowing between one of the electrodes 201 and one of the electrodes 205 or 130, an impedance can be calculated based on the voltage applied and the actual current value. This impedance is different for different distances between electrodes, and therefore, the impedance is used to estimate distances between electrodes.

Alternatively, instead of using impedances, voltage potentials between electrodes may be used. For example, when a current is flowing between one of the electrodes 201 and one of the electrodes 205 or 130, an electric field is generated in the same direction as the current. Then a voltage potential, based on the electric field, is measured between two non-transmitting and/or non-receiving electrodes, such as between an electrode 201 adjacent to the transmitting and/or receiving electrode 201 and an electrode 205 or 130 adjacent to the transmitting and/or receiving electrode 205 or 130. The voltage potential is different for different distances between electrodes, and, therefore, the voltage potential is used to estimate distances between electrodes.

In act 625, a position of the catheter 124 is determined based on the electrical characteristic. For example, estimated distances are determined based on the impedance or voltage potential values using a transfer function or any other mathematical technique. Because the position of the reference electrodes 205 and/or 130 are known, the position of the electrodes 201 are determined based on the estimated distances using standard triangulation formulas, trigonometric equations, and/or any other known or future mathematical techniques to derive a three point coordinate position of the electrode 201. The correlated calibration values are used to adjust the estimated distances to obtain more accurate position data. Because the positions of the electrodes 201 on the catheter 124 are predetermined, the position of the catheter 124 may be determined.

The position data of the catheter 124 is used in conjunction with volume data or other image data of the patient 112 to create a 3D or virtual image of the catheter 124 during or after the medical procedure. For example, the imaging system 100 or a separate imaging system gathers image data of an area of the patient 112 associated with the positioning of the catheter 124. The image data may be obtained during or before the medical procedure involving the catheter 124. Based on the image data, a 3D image is generated. Any known or future image construction technique may be utilized. For example, volume rendering (including voxel arrangement, coordinate transformation, ray casting, and lighting calculations), surface rendering, image mesh techniques, and/or any other mathematical or digital signal processing method for generating 3D images is used. The position data of the catheter 124

is superimposed or combined with the 3D image of the internal area of the patient **112** to allow a medical professional view a virtual catheter during or after the medical procedure.

Also, changes in position of internal anatomy based on a heart, breathing, or other physiological cycle may impact the positions of the catheter **124**, the reference catheters **128**, and/or the body surface electrodes **130**. To limit effects of physiological cycles, the imaging system **100**, another imaging system, and/or the electrode system **120** generates a physiological cycle waveform. The cycle or a portion thereof is used for triggering purposes when electrical characteristic measurements between electrodes are acquired. Alternatively, motion artifacts are corrected by creating a 4D motion function of the electrodes by filming an image sequence, such as an X-ray image sequence, through one heart beat or respiration cycle. Within each cycle, each electrode is given a 3D coordinate for each frame by image segmentation. The electrodes will then be described by a position function. For example, electrode position= $f(x(t), y(t), z(t))$ , where  $f$  is a function in three dimensional space. Once  $f$  has been derived, the position in each X-ray frame is correlated to a certain timestamp during the physiological cycle. The timestamp information is synchronized with the motion of the electrodes, and, therefore, the motion artifacts may be removed.

Any or all of the data generated by the catheter **124**, the reference catheters **128**, the body surface electrodes **130**, the imaging system **100**, and/or the electrode system **120** is stored in the memory **140** and/or **130**. Additionally, instructions executable by the processor **102** and/or **130** are stored in a computer-readable medium, such as the memory **106** and/or **140**. The instructions implement the methods, acts, and processes described above. The instructions for implementing the processes, methods and/or techniques discussed above are provided on computer-readable storage media or memories, such as a cache, buffer, RAM, removable media, hard drive or other computer readable storage media. Computer readable storage media include various types of volatile and nonvolatile storage media. The functions, acts or tasks illustrated in the figures or described herein are executed in response to one or more sets of instructions stored in or on computer readable storage media. The functions, acts or tasks are independent of the particular type of instructions set, storage media, processor or processing strategy and may be performed by software, hardware, integrated circuits, firmware, micro code and the like, operating alone or in combination. Likewise, processing strategies may include multiprocessing, multitasking, parallel processing and the like. In one embodiment, the instructions are stored on a removable media device for reading by local or remote systems. In other embodiments, the instructions are stored in a remote location for transfer through a computer network or over telephone lines. In yet other embodiments, the instructions are stored within a given computer, CPU, GPU or system. Also, any of the features, methods, techniques described may be mixed and matched to create different systems and methodologies.

Any of the features, components, and methods described above may be mixed and matched to provide for a variety of electrode positioning systems and methodologies. For example, more or less acts may be performed to accomplish the same end of determining a position of the catheter **124**.

While the invention has been described above by reference to various embodiments, it should be understood that many changes and modifications can be made without departing from the scope of the invention. It is therefore intended that the foregoing detailed description be regarded as illustrative rather than limiting, and that it be understood that it is the

following claims, including all equivalents, that are intended to define the spirit and scope of this invention.

I claim:

**1.** A system for determining a position of a catheter, the system comprising:

an electrode on the catheter;

a plurality of reference electrodes, each reference electrode of the plurality of reference electrodes configured to transmit or receive a signal to or from the electrode; and a processor configured to;

determine a first distance between a reference electrode of the plurality of reference electrodes and the electrode as a function of an electrical characteristic based on one of the signals;

determine a second distance between the reference electrode and the electrode using an image for viewing the catheter;

determine a correlation between the first distance and the second distance; and

determine the position of the catheter as a function of the electrical characteristic or another electrical characteristic based on the signals, and the determined correlation,

wherein the plurality of reference electrodes is not positioned on or in a body surface along three mutually orthogonal axes.

**2.** The system of claim **1**, wherein the signals corresponding to the plurality of reference electrodes are substantially at a same frequency.

**3.** The system of claim **1**, wherein the electrical characteristic comprises an impedance determined by the one signal between the reference electrode of the plurality of reference electrodes and the electrode, the impedance used for determining a position of the electrode.

**4.** The system of claim **3**, wherein the plurality of reference electrodes comprises body surface electrodes.

**5.** The system of claim **4**, wherein the body surface electrodes comprise electrocardiogram electrodes.

**6.** The system of claim **1**, further comprising:

a first reference catheter,

wherein a first set of reference electrodes of the plurality of reference electrodes is on the first reference catheter.

**7.** The system of claim **6**, further comprising:

a second reference catheter,

wherein a second set of reference electrodes of the plurality of reference electrodes is on the second reference catheter.

**8.** The system of claim **1**, wherein the processor is configured to determine the position of the catheter using a predetermined look-up table, the predetermined look-up table including data representing distance values that correlate to data representing combinations of different impedance values.

**9.** A system for determining a position of a catheter, the system comprising:

a first electrode and a second electrode on the catheter;

a plurality of reference electrodes, each reference electrode of the plurality of reference electrodes configured to transmit or receive a signal to or from the first electrode and the second electrode, respectively; and

a processor configured to determine a position of the catheter as a function of a voltage potential between the second electrode and one reference electrode of the plurality of reference electrodes when the first electrode and another electrode of the plurality of reference electrodes are transmitting and receiving the signal, respectively.

**13**

10. The system of claim 9, wherein the voltage potential is based on an electric field generated by the signal.

11. The system of claim 9, wherein the first electrode and the second electrode are adjacent electrodes.

12. The system of claim 9, wherein the plurality of reference electrodes comprises body surface electrodes. 5

**14**

13. The system of claim 9, further comprising:  
a reference catheter,  
wherein the plurality of reference electrodes is on the reference catheter.

\* \* \* \* \*

|                |                           |                       |            |
|----------------|---------------------------|-----------------------|------------|
| 专利名称(译)        | 电极导管定位系统                  |                       |            |
| 公开(公告)号        | <a href="#">US8311613</a> | 公开(公告)日               | 2012-11-13 |
| 申请号            | US11/820697               | 申请日                   | 2007-06-20 |
| [标]申请(专利权)人(译) | DANEHORN KENNETH          |                       |            |
| 申请(专利权)人(译)    | DANEHORN KENNETH          |                       |            |
| 当前申请(专利权)人(译)  | 西门子医疗GMBH                 |                       |            |
| [标]发明人         | DANEHORN KENNETH          |                       |            |
| 发明人            | DANEHORN, KENNETH         |                       |            |
| IPC分类号         | A61B5/00                  |                       |            |
| CPC分类号         | A61M25/01 A61M2025/0166   |                       |            |
| 其他公开文献         | US20080319297A1           |                       |            |
| 外部链接           | <a href="#">Espacenet</a> | <a href="#">USPTO</a> |            |

摘要(译)

提供了一种用于确定导管位置的系统。电极在导管上。提供多个参考电极。多个参考电极中的每一个被配置为分别向电极发送信号或从电极接收信号。处理器可操作以基于信号确定导管的位置作为电特性的函数。多个参考电极不沿三个相互正交的轴定位在体表上或体表中。

