



US 20130116522A1

(19) **United States**

(12) **Patent Application Publication**
CINBIS et al.

(10) **Pub. No.: US 2013/0116522 A1**
(43) **Pub. Date: May 9, 2013**

(54) **SYSTEM FOR IDENTIFYING THE LOCATION OF A DEVICE WITHIN A PATIENT'S BODY IN ORDER TO LOCATE THE FOSSA OVALIS FOR TRANS-SEPTAL PROCEDURES**

Publication Classification

(51) **Int. Cl.**
A61B 5/1459 (2006.01)
A61B 5/06 (2006.01)
A61B 5/00 (2006.01)
A61B 5/1455 (2006.01)

(52) **U.S. Cl.**
 CPC *A61B 5/1459* (2013.01); *A61B 5/14552* (2013.01); *A61B 5/061* (2013.01); *A61B 5/6852* (2013.01); *A61B 5/064* (2013.01); *A61B 5/72* (2013.01); *A61B 5/0044* (2013.01)
 USPC **600/339**

(71) Applicant: **MEDTRONIC ABLATION FRONTIERS LLC**, Minneapolis, MN (US)

(72) Inventors: **Can CINBIS**, Shoreview, MN (US);
Xiaonan SHEN, Shoreview, MN (US);
Jonathan KUHN, Ham Lake, MN (US)

(73) Assignee: **MEDTRONIC ABLATION FRONTIERS LLC**, Minneapolis, MN (US)

(21) Appl. No.: **13/731,162**

(22) Filed: **Dec. 31, 2012**

Related U.S. Application Data

(63) Continuation of application No. 12/696,488, filed on Jan. 29, 2010, now Pat. No. 8,369,932.

(57) **ABSTRACT**

A system and method for identifying the location of a medical device within a patient's body may be used to localize the fossa ovalis for trans-septal procedures. The systems and methods measure light reflected by tissues encountered by an optical array. An optical array detects characteristic wavelengths of tissues that are different distances from the optical array. The reflectance of different wavelengths of light at different distances from an optical array may be used to identify the types of tissue encountered, including oxygenated blood in the left atrium as detected from the right atrium through the fossa ovalis.

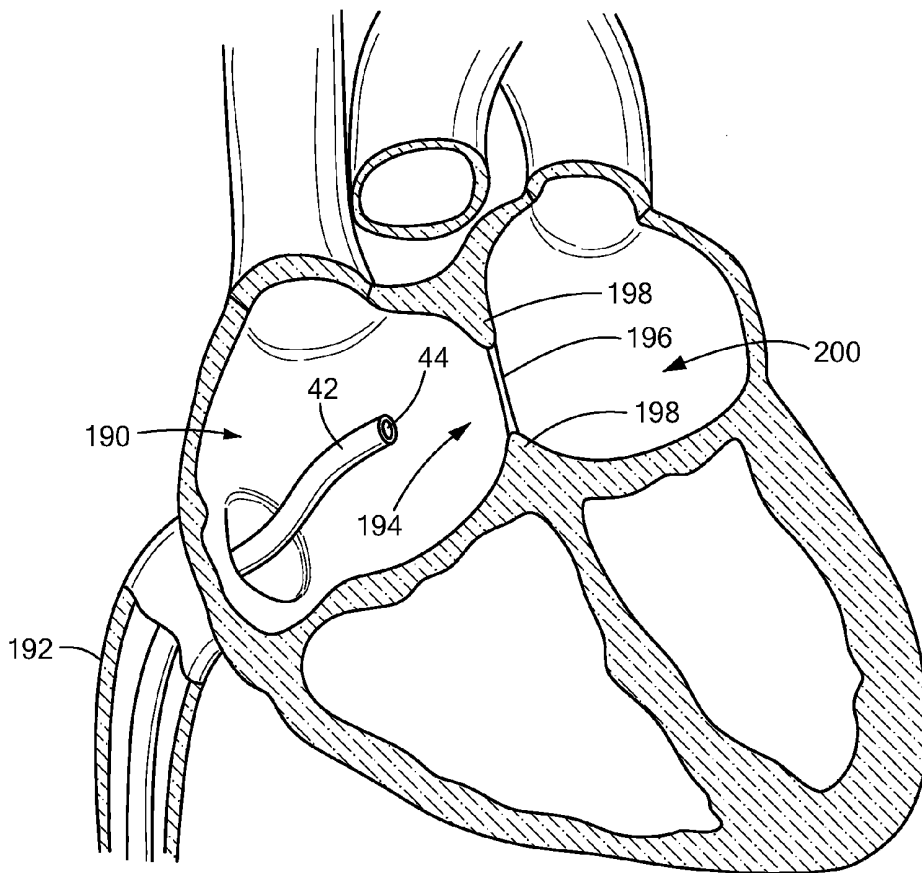

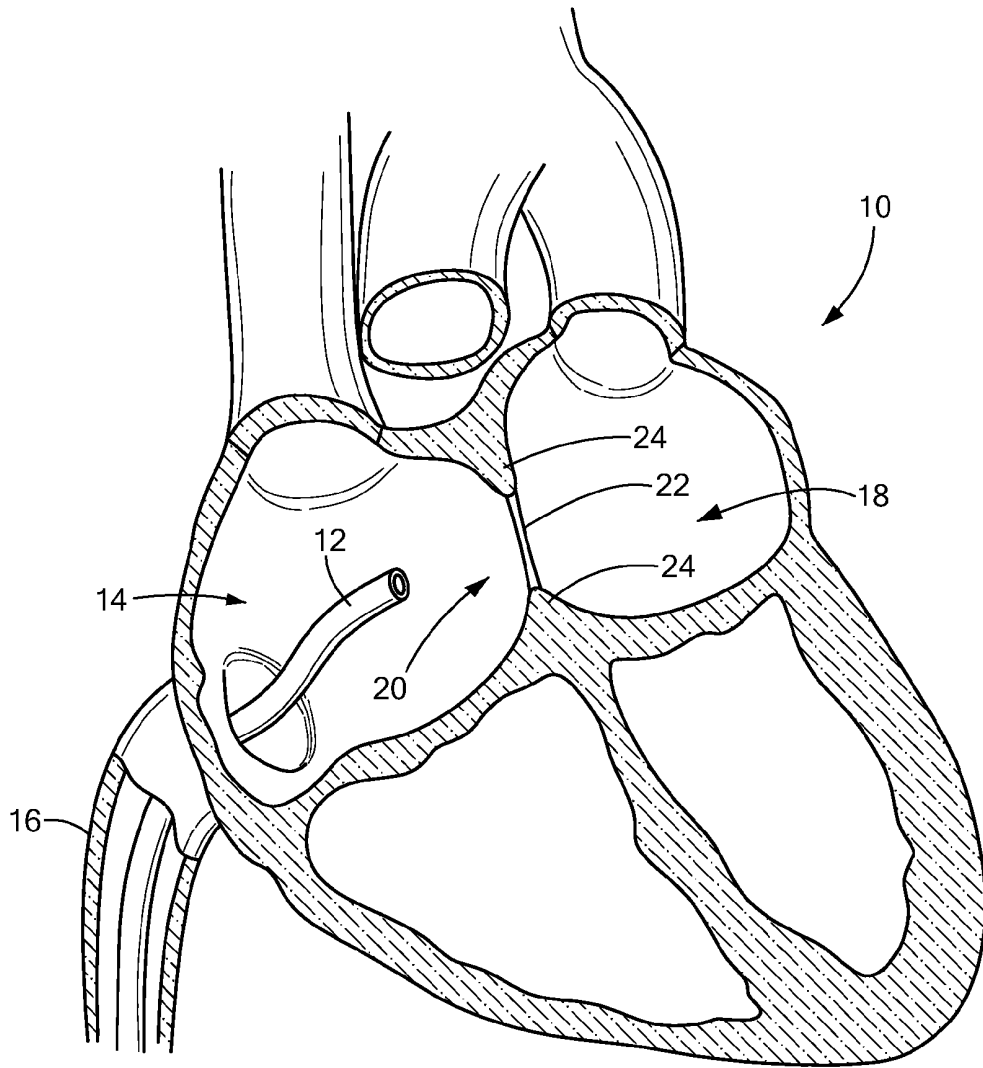

FIG. 1

PRIOR ART

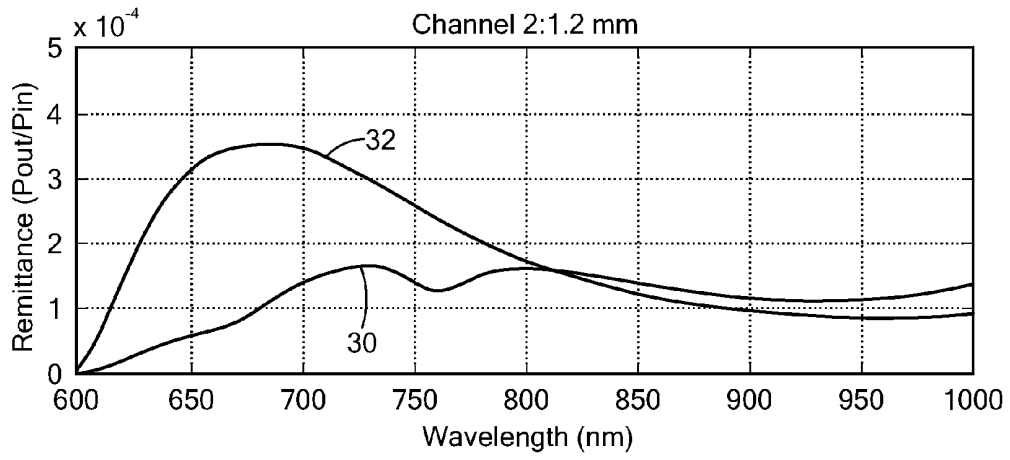

FIG. 2
PRIOR ART

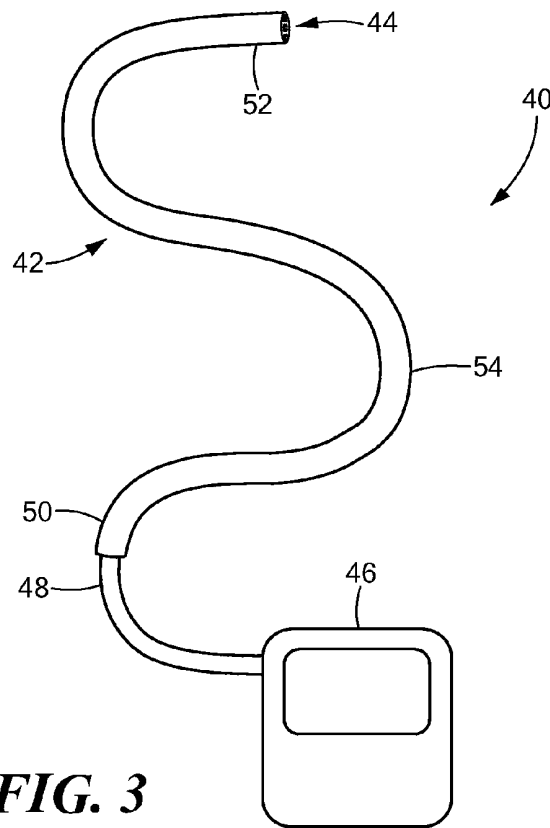

FIG. 3

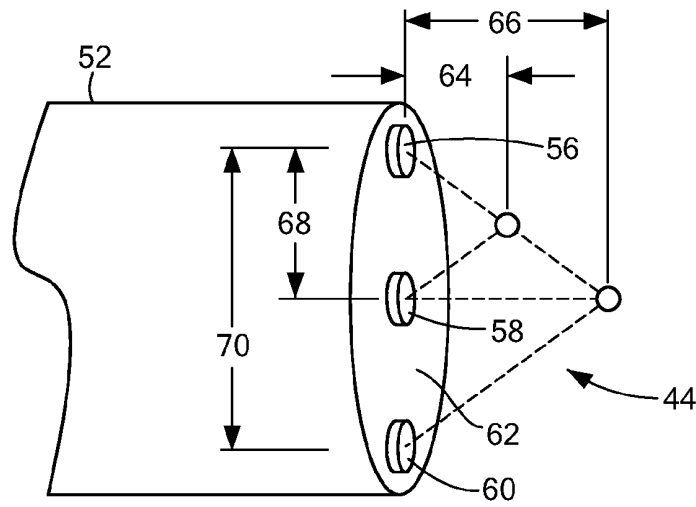

FIG. 4

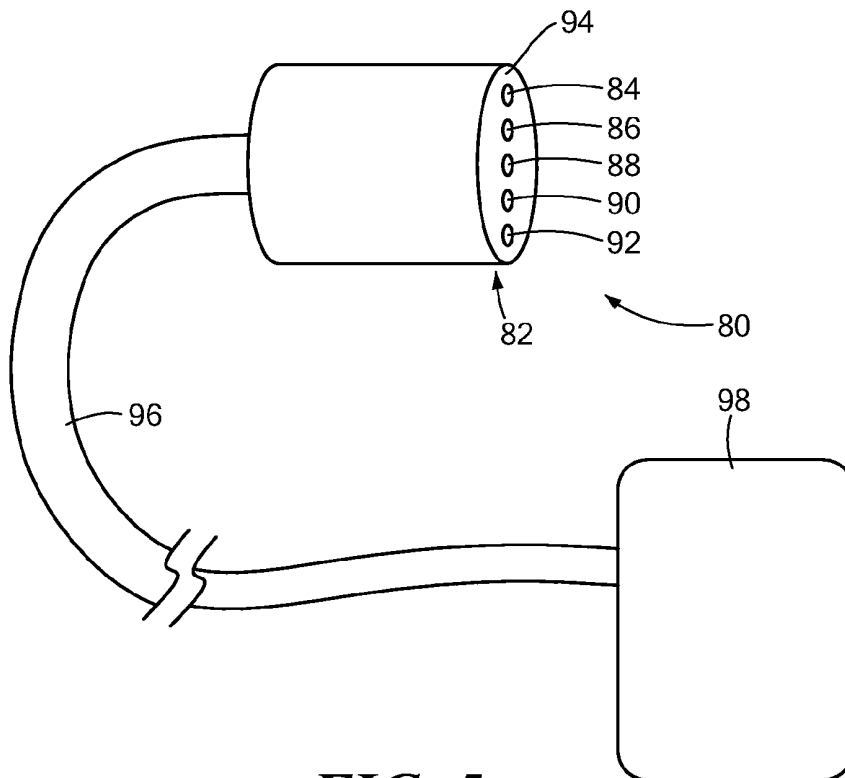

FIG. 5

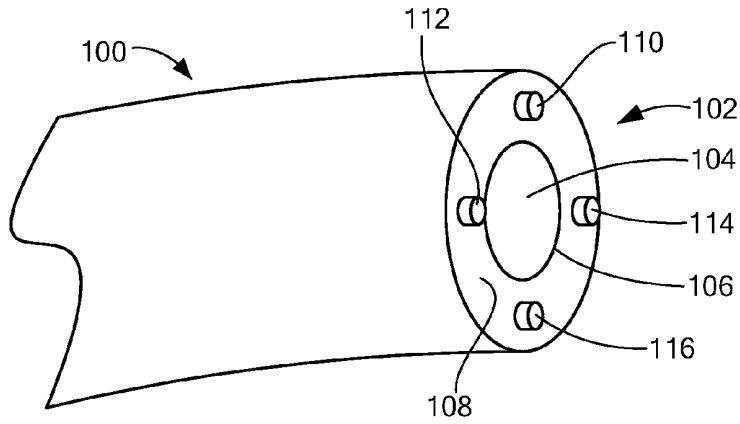

FIG. 6

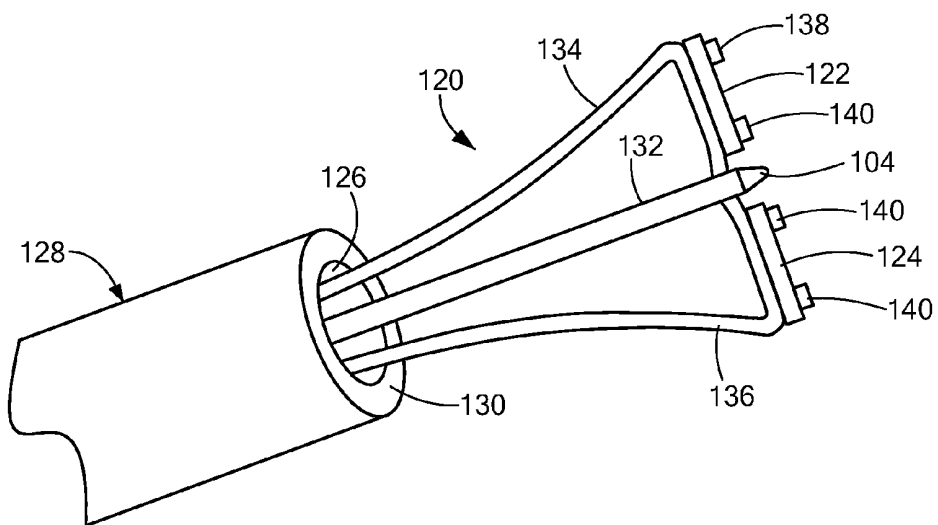

FIG. 7

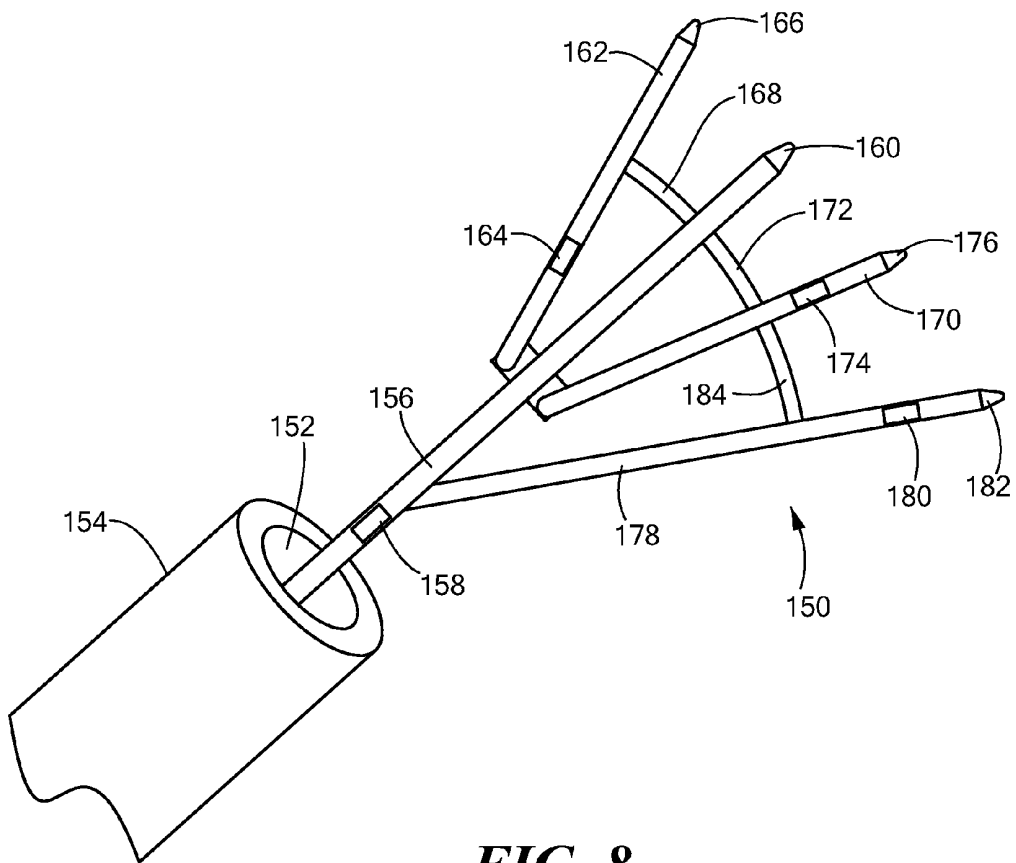

FIG. 8

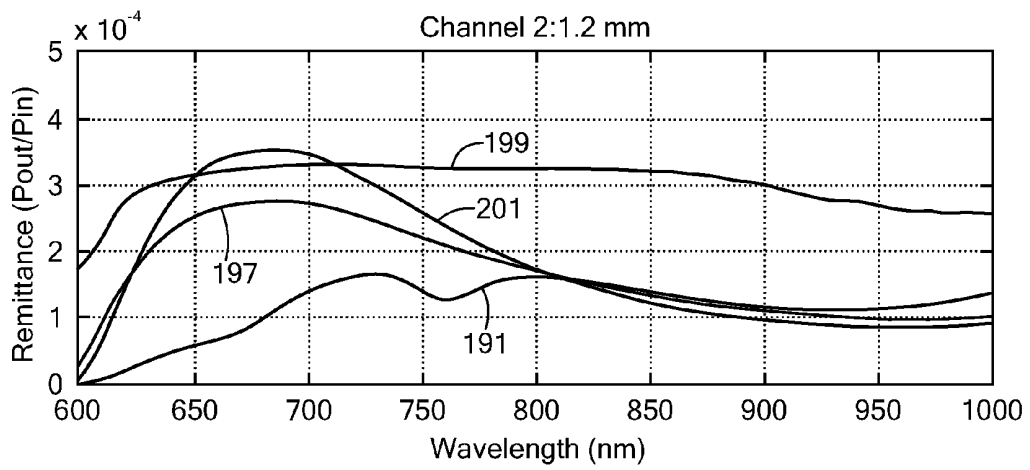
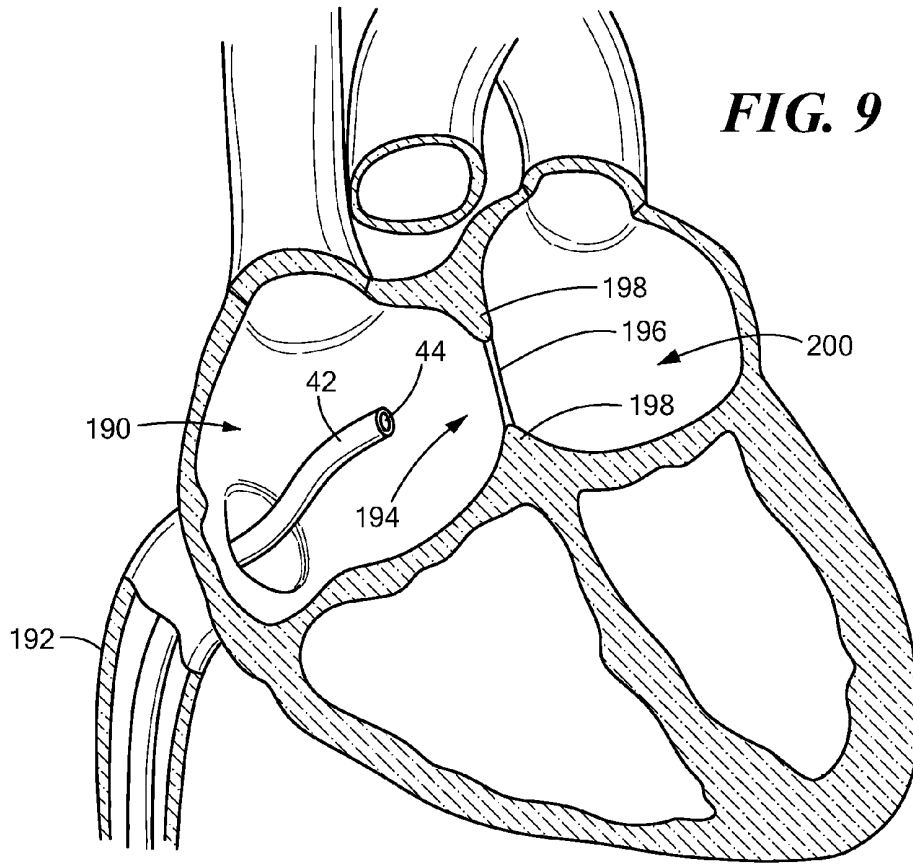

FIG. 10

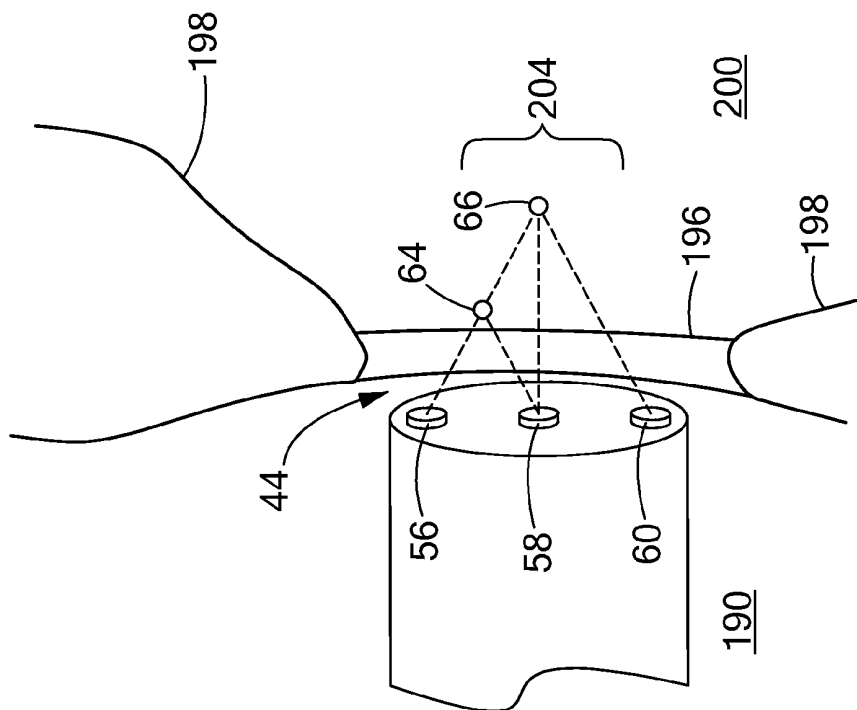

FIG. 11

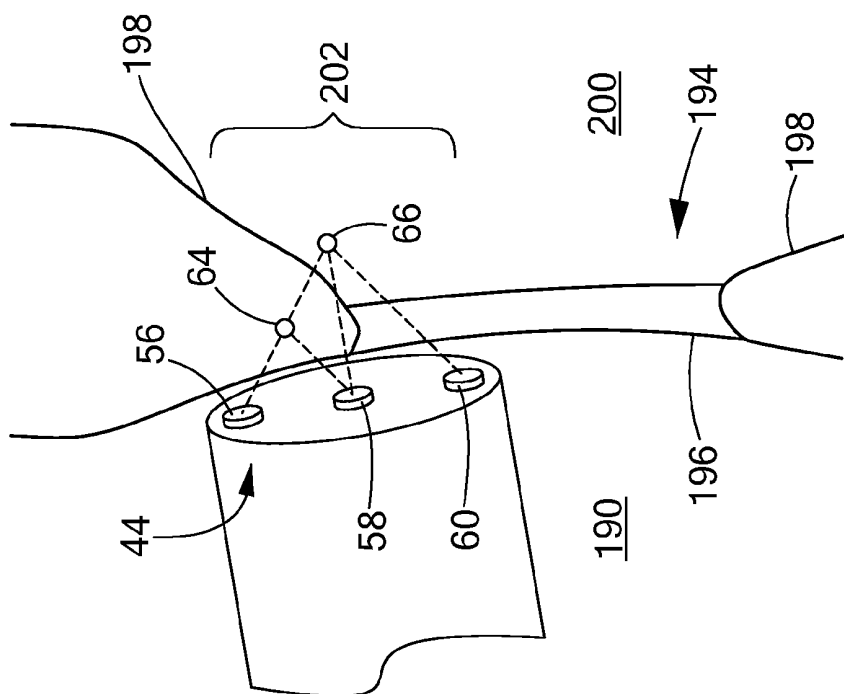

FIG. 12

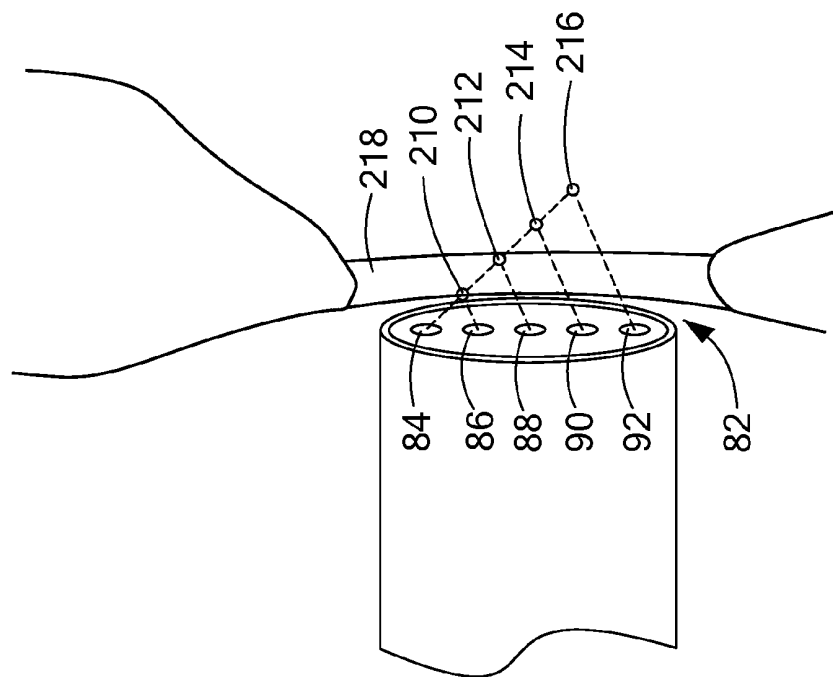

FIG. 13

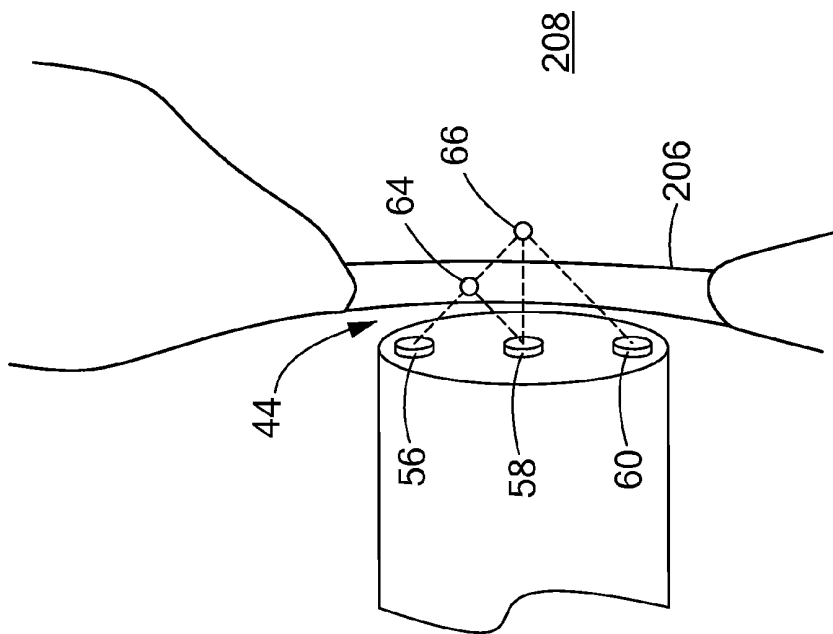

FIG. 14

**SYSTEM FOR IDENTIFYING THE
LOCATION OF A DEVICE WITHIN A
PATIENT'S BODY IN ORDER TO LOCATE
THE FOSSA OVALIS FOR TRANS-SEPTAL
PROCEDURES**

**CROSS-REFERENCE TO RELATED
APPLICATION**

[0001] This application is a continuation of patent application Ser. No. 12/696,488, filed Jan. 29, 2010, entitled OPTICAL METHOD OF IDENTIFYING THE LOCATION OF A MEDICAL DEVICE WITHIN A PATIENT'S BODY IN ORDER TO LOCATE THE FOSSA OVALIS FOR TRANS-SEPTAL PROCEDURES, the entirety of which is incorporated herein by reference.

**STATEMENT REGARDING FEDERALLY
SPONSORED RESEARCH OR DEVELOPMENT**

[0002] n/a

FIELD OF THE INVENTION

[0003] The present invention relates to a system and method for optically identifying the position of a medical device within a patient, and particularly for using optical methods for identifying an optimal region of the interatrial septum of the heart for puncturing during a trans-septal procedure.

BACKGROUND OF THE INVENTION

[0004] Catheterization procedures have become the preferred methods for treating a variety of heart conditions. A catheter has a long, flexible body that may be introduced into the vasculature and guided into the heart or another organ of the body. By incorporating various medical devices, for example an ablation device, into the distal portion of a catheter, it may be used for ablation, as well as other procedures including angioplasty, dilation, biopsy and other procedures within the human heart and elsewhere.

[0005] For certain cardiovascular procedures, a catheter is inserted into an artery or vein in the leg, neck, torso or arm and threaded through the vasculature into the heart. FIG. 1 (prior art) shows a human heart 10 into which a catheter 12 has been introduced. In a common procedure, a catheter 12 enters into the right atrium 14 through the inferior vena cava 16. From the right atrium 14, the catheter may be directed to other regions of the heart.

[0006] Many procedures require introducing the catheter to the left atrium 18. One method of entering the left atrium 18, known as a trans-septal procedure, includes first entering the right atrium 14 through the vena cava 16 and then puncturing the interatrial septum 20. The interatrial septum 20 is the portion of the atrial wall which divides the left and right atria. Once the interatrial septum 20 is punctured, the end of the catheter 12 proceeds into the left atrium 18 where it may perform ablation or other medical treatments.

[0007] At the center of the interatrial septum 20 is a thin fibrous region known as the fossa ovalis 22. The fossa ovalis 22 is surrounded by the muscular tissue 24 of the atrial walls. The fossa ovalis 22 is relatively thin and does not include muscular tissue, making it the generally preferred region in which to puncture the interatrial septum during trans-septal procedures. Puncturing of the muscular tissue surrounding the fossa ovalis causes unwanted damage to the heart.

[0008] Accurate localization and identification of the fossa ovalis presents significant challenges. The fossa ovalis is invisible to current imaging techniques used to visualize a catheter during intercardial procedures, such as fluoroscopy. As a result, a physician must rely upon his own skill to position the tip of a catheter prior to puncturing the fossa ovalis.

[0009] Another difficulty encountered during trans-septal procedures is the variance in the thickness of the fossa ovalis between different individuals. Without knowing the approximate thickness of the fossa ovalis being punctured, a surgeon does not know how far a puncturing device on a catheter must travel or how much force is required in order to traverse the fossa ovalis. Thus an additional risk inherent in trans-septal procedures is that too much force will be applied to the catheter, resulting in piercing both the fossa ovalis and other structures within the heart such as the heart wall or aorta in unnecessary and undesirable locations.

[0010] One method of identifying the fossa ovalis uses spectroscopy and the ability of light to penetrate some thickness of tissue. The blood in the right atrium, where the catheter is introduced into the heart, is filled with deoxygenated blood that has a characteristic absorption spectrum 30 shown in FIG. 2. The absorption spectrum 30 of deoxygenated, right atrium blood differs significantly from the absorption spectrum 32 of the oxygenated blood found in the left atrium, particularly within the range of 600 nm to 805 nm. Because the fossa ovalis is very thin, the oxygenated blood of the left atrium may be viewed by an optical device abutting the fossa ovalis.

[0011] The fossa ovalis is the only region of the right atrium where oxygenated blood and its characteristic spectrum may be observed. Thus, a catheter may incorporate an optical device that illuminates the blood and tissue surrounding the catheter tip and detect the spectrum reflected back. When such an optical device detects the absorption spectrum of oxygenated blood, the device is abutting the fossa ovalis. Thus, by moving a catheter tip about the right atrium and particularly around the atrial wall of the right atrium, an operator of a catheter device may identify the fossa ovalis prior to puncturing the interatrial septum.

[0012] However, the nature of the optical device may create difficulties in accurately identifying the fossa ovalis. The light being reflected and observed by the detector must travel far enough to be reflected by the oxygenated blood of the left atrium. Where an optical device has an emitter for illuminating surrounding tissue and a detector for observing the absorption spectra positioned very close to each other, most of the observed reflected light is reflected from the fossa ovalis itself and not the oxygenated blood of the left atrium. Thus, the fossa ovalis may not be accurately localized.

[0013] If, on the other hand, the emitter and detector are relatively far apart, the detector may observe light reflected from the left atrium even though it traveled through the muscular wall, not the fossa ovalis. As a result, a portion of the interatrial septum having muscular tissue may be mistakenly identified as the fossa ovalis. Thus, a trans-septal puncture may be inadvertently made through muscular tissue, causing unnecessary damage.

[0014] It is therefore desirable to provide a system and method for identifying the location of a medical device within a patient and particularly for accurately identifying when a medical device is abutting the fossa ovalis. It is also desirable

to be able to measure light reflected from different distances from the tip of the catheter within the body.

SUMMARY OF THE INVENTION

[0015] The present invention provides a method for identifying the location of a medical device within a patient. Light is emitted from an emitter toward at least one tissue within a body. The reflected light is measured by two or more receivers which are separated by different distances from the emitter. The measured reflected light may then be used to calculate a remittance value for two wavelengths at each of the receivers. A remittance ratio is then calculated by dividing the remittance values of the two wavelengths for each receiver. This may be done with wavelengths ranging between 600 nm and 1000 nm. Specific wavelengths 660 nm and 940 nm may be measured using this technique.

[0016] In addition, the slope of the remittance values over the wavelength range may be calculated for the light detected by each of the receivers. Optionally, the curvature over the range of wavelengths may be calculated to identify the characteristic spectra of oxygenated blood and other tissue. The emitter and receivers may be incorporated onto a face plate.

[0017] A medical device for identifying the location of a medical device within a patient's body includes an intravascular catheter and an optical array. The optical array has one or more emitters for emitting light and receivers for detecting reflected light, wherein the receivers are not all equidistant from the emitter. The medical device also includes a spectrometer in communication with the emitter and the receivers. The emitter and receivers may be on a face plate. The optical array may be inserted into a lumen in a catheter and protrude from a distal region of the catheter and have two face plates.

[0018] A face plate may be annular and surrounding an opening to a lumen in the catheter. The face plate may abut an interatrial septum and may be moved across the interatrial septum and detect light from a plurality of locations along the interatrial septum.

BRIEF DESCRIPTION OF THE DRAWINGS

[0019] A more complete understanding of the present invention, and the attendant advantages and features thereof, will be more readily understood by reference to the following detailed description when considered in conjunction with the accompanying drawings wherein:

[0020] FIG. 1 is a view of a human heart having a catheter inserted into the right atrium;

[0021] FIG. 2 is a graph of absorption spectra of various tissues found within the human heart;

[0022] FIG. 3 is an embodiment of a medical device constructed in accordance with the principles of the present invention;

[0023] FIG. 4 is an enlarged view of the optical array of the medical device of FIG. 3;

[0024] FIG. 5 is an alternative embodiment of a medical device constructed in accordance with the principles of the present invention;

[0025] FIG. 6 is an alternative embodiment of an optical array constructed in accordance with the principles of the present invention;

[0026] FIG. 7 is an alternative embodiment of an optical array constructed in accordance with the principles of the present invention;

[0027] FIG. 8 is an alternative embodiment of an optical array constructed in accordance with the principles of the present invention;

[0028] FIG. 9 is a perspective view of the medical device of FIG. 3 in a human heart;

[0029] FIG. 10 a graph of absorption spectra of various tissues found within the human heart;

[0030] FIG. 11 is an enlarged view of the optical array of FIG. 4 abutting an interatrial septum;

[0031] FIG. 12 is an enlarged view of the optical array of FIG. 4 abutting the fossa ovalis of an interatrial septum;

[0032] FIG. 13 is an enlarged view of the optical array of FIG. 4 abutting another interatrial septum; and

[0033] FIG. 14 is an enlarged view of the optical array of FIG. 5 abutting a fossa ovalis.

DETAILED DESCRIPTION OF THE INVENTION

[0034] The present invention provides a system and methods of use thereof for characterizing the optical characteristics of tissue surrounding a medical device within a patient. In particular, the present invention provides a medical system and methods of use thereof for identification of a targeted tissue type.

[0035] Referring now to the drawing figures in which like reference designations refer to like elements, an embodiment of a medical system 40 constructed in accordance with principles of the present invention is shown in FIG. 3. The medical system 40 generally includes a catheter 42 having an optical array 44 coupled to a spectrometer 46 through an umbilical system 48.

[0036] The catheter 42 comprises a proximal portion 50, a distal portion 52 and an elongate flexible tubular body 54. The distal portion 52 of the catheter 42 may include an ablation element, a balloon and/or one or more sensors to monitor various parameters including for example pressure, temperature, flow rate, volume, or the like. The catheter 42 may also optionally include one or more lumens disposed within the elongate body, thereby providing mechanical, electrical, and/or fluid communication between the proximal portion 50 and the distal portion 52 of the catheter. The catheter 42 may be made of a flexible material and may be typically 80 cm to 100 cm long, but may optionally be shorter or longer. The body 54 of the catheter 42 may be typical of catheters for use in trans-septal procedures that include introducing the distal portion of the catheter into the right atrium of the heart and proceeding into the left atrium by puncturing the interatrial septum. All or a portion of the catheter 42 may optionally be comprised of radiopaque material or may include one or more radiopaque markers.

[0037] The umbilical 48 may be a bundle of optical fibers or electrical wires placing the spectrometer 46 in communication with the optical array 44. Other umbilicals may optionally be used to operate other sensors or other devices, for example an ablation device. The spectrometer 46 may include processors that may analyze optical data, for example the wavelengths and amplitudes of the emitted light and the wavelengths and amplitudes of detected reflected light at particular wavelengths. The spectrometer 46 may provide one or more graphs of the data or may optionally perform mathematical analyses on the data, as explained in more detail below.

[0038] Referring now to FIG. 4, the optical array 44 is shown in more detail. The optical array 44 includes an emitter 56 for emitting light directed at tissue surrounding and in

front of the distal portion **52** of the catheter **42** of FIG. 3. The emitter **56** may be composed of any device suitable for emitting light, for example a light-emitting-diode or similar device. Optionally, the emitter **56** may be a plate or window, comprised of for example glass, acrylic or other transparent material, in communication with an optical fiber that provides light to the emitter **56**. The emitter **56** also may simply be the end of an optical fiber. The light emitted by the emitter **56** may be a broad band of light ranging over several wavelengths or may be of selected discrete wavelengths. The emitter **56** may further include a filter (not shown) for filtering the type of light emitted. Optionally, a plurality of emitters may be used.

[0039] The optical array **44** also includes two receivers **58** and **60** for detecting light reflected from adjacent tissue(s). As used herein, the term "tissue" refers generally to any tissue within the human body, such as muscle, fibrous tissue, blood, and others. The receivers **58** and **60** may be comprised of any device known to detect light. The receivers may be a plate or window, comprised of for example glass, acrylic, or other transparent material, in communication with an optical fiber and transmitting detected light to the optical fiber. The receivers **58** and **60** may also simply be the end of an optical fiber. The receivers **58** and **60** may optionally be devices that measure various parameters of detected light, for example wavelengths, amplitudes and/or other parameters, and generate an electrical or other signal containing information about the measured parameters. The receivers **58** and **60** may detect a broad range of wavelengths or only selected wavelengths, and may optionally include filters for selecting which wavelengths are detected.

[0040] The optical array **44** may be located on the face plate **62** positioned at the distal portion **52** of the catheter **42**. The face plate **62** may be substantially planar and optionally may be substantially perpendicular to the longitudinal axis of the catheter **42**. Optionally, the distal portion **52** of the catheter **42** may include a radiopaque marker, not shown, which may be on the face plate **62**. Optionally, all or part of the catheter **42** may be composed of a radiopaque material.

[0041] FIG. 4 also illustrates the relationship between the distance between the emitter **56** and the receivers **58** and **60** and their respective target depths of penetration **64** and **66**. As used herein, the term "target depth" refers generally to the penetration distance of light from emitters to within tissue where the main spatial distribution of light reaches a maximum depth. There is a linear correlation between the distance between an emitter and a receiver and a distance light travels into a tissue in order to be detected. The optical array **44** therefore may acquire spectral information from tissue(s) at different distances from the optical array because it has two receivers that are at different distances from the emitter. The distance **68** separates the emitter **56** and the receiver **58** from each other. As a result, any light detected by the receiver **58** travels to the depth of penetration **64** or further. Light reflected from a point closer to the optical array **44** may not be detected by receiver **58**.

[0042] Similarly, reflected light detected by the receiver **60** travels at least to the target depth of penetration **66**. Because the distance **70** separates the emitter **56** and the receiver **60** from one another, any light detected by receiver **60** travels at least to the target depth of penetration **66**. Where the distance **70** is twice the distance **68**, the depth of penetration **66** for the receiver **60** will be approximately twice the distance **64** for

the receiver **58**. Incorporation of the emitter **56** and the receivers **58** and **60** into the face plate **62** may allow these distances to remain constant.

[0043] While the correlation between the distance between an emitter and a receiver and the depth of penetration may be generally linear, the actual depth of penetration for a given distance between an emitter and receiver may be affected by a variety of factors and may be determined empirically. The correlation may depend on the wavelengths used, the geometry of the emitter and the receiver, the type of tissue, and other factors.

[0044] Referring now to FIG. 5, an alternative medical device **80** has an optical array **82** including an emitter **84** and a series of four receivers **86**, **88**, **90** and **92** linearly arranged at increasing distances from the emitter **84**. The optical array **82** may be insertable into the lumen of a catheter such that it may be removably placed at the distal portion of the catheter instead of as an integral component of the catheter itself. The optical array **82** may also include a face plate **94** into which the emitter **84** and the receivers **86**, **88**, **90** and **92** may be incorporated. An umbilical **96** connects the optical array **82** to a spectrometer **98** that may provide light to be emitted to the emitter **84** and may measure light detected by the receivers **86**, **88**, **90** and **92** in order to analyze the spectroscopic data collected. Optionally, the umbilical **96** may include electrical wires capable of transmitting signals from the emitter **84** and the receivers **86**, **88**, **90** and **92** to the spectrometer **98**. Because all four receivers **86**, **88**, **90** and **92** are different distances from the emitter **84**, they all observe light traveling to different depths of penetration.

[0045] Referring now to FIG. 6, a catheter **100** has an optical array **102** and a lumen **104** that extends its length and allows various instruments to be inserted into the catheter **100** such that they protrude from the lumen opening **106**. For example, a piercing or puncturing instrument such as a needle may be passed through the lumen **104** and out of the opening **106** to facilitate puncturing of the fossa ovalis once it has been localized using the optical array **102**. The puncturing instrument may then be withdrawn and replaced with an ablation or other instrument.

[0046] The optical array **102** of the catheter **100** may be located on an annular, planar face plate **108** surrounding the lumen opening **106**. The face plate **108** may be flat and lie in a plane substantially perpendicular to the longitudinal axis of the catheter **100**. The emitter **110** emits light of discrete wavelengths or a band of wavelengths. The receivers **112** and **114** may be equidistant from the emitter **110**. The two receivers **112** and **114** may have the same depths of penetration. The receiver **116** may be farthest from the emitter **110** and allows the optical array **102** to gather spectroscopic data from regions farther from the face plate **108**.

[0047] Referring now to FIG. 7, an optical array **120** having two face plates **122** and **124** may be collapsed and inserted into a lumen **126** in a catheter **128**. Once it has traversed the length of the catheter **128** and protrudes out at the distal portion **130** of the catheter **128**, the optical array **120** may be expanded. The optical array **120** may be mounted on a wire **132** which supports the optical array **120** and may have a radiopaque marker **104** to assist in observing the position of the optical array **120**. The face plates **122** and **124** may be supported by the cables **134** and **136** respectively. The optical array **120** may be expanded so that the face plates **122** and **124** may be parallel and the emitter **138** and the receivers **140** all align in a single plane. By adjusting the cables **134** and **136**,

the face plates **122** and **124** may be adjusted such that they may not be parallel and/or not lie in the same plane.

[0048] Referring now to FIG. **8**, an optical array **150** may be collapsed so that it may fit through the lumen **152** of the catheter **154**. Upon exiting the lumen **152**, the optical array **150** may be expanded using cables, not shown. The optical array **150** may be mounted on a wire **156** which may have a radiopaque marker **158** and a receiver **160**. The expanding arm **162** also may have a radiopaque marker **164** and an emitter **166**. Optionally, some or all of the optical array **150** may be comprised of a radiopaque material. The expanding arm **162** expands to a distance from the wire **156** determined by the length of the cable **168**. Similarly, the expanding arm **170** expands to a distance from the wire **156** determined by the length of the cable **172**, and includes a radiopaque marker **174** and a receiver **176**. The expanding arm **178** includes a radiopaque marker **180** and a receiver **182** and expands to a predetermined distance determined by the length of the cable **184**. The expanding arms **162**, **170** and **178** each have a specific length such that when expanded, the emitter **166** and the receivers **160**, **176** and **182** all lie in the same plane. By adjusting the lengths of the cables **138**, **142** and **184**, the plane in which the receivers lie may be warped so that it may be concave or convex. Additional expanding arms may optionally be included to provide additional receivers. The optical array **150** does not include a face plate. By using expanding arms that when expanded place the emitter **166** and receivers **160**, **176** and **182** at known positions relative to each other, their respective depths of penetration may be determined.

[0049] Referring now to FIGS. **9-13**, in an exemplary method of use, the medical system **40** of FIG. **3** may be used to acquire optical information for a targeted tissue area. Specifically, the medical system **40** may be used to localize the fossa ovalis during a trans-septal procedure. Catheter **42** may be introduced into the right atrium **190** after being routed through the vascular system, for example, through the inferior vena cava **192**. The superior vena cava may optionally be utilized for jugular or subclavian insertions. Traversing the vasculature and positioning of the optical array **44** may be aided by imaging techniques (fluoroscopy, etc.). Once in the vicinity of the targeted tissue, the optical array **44** may be advanced at least partially into contact with the atrial wall, of which the interatrial septum **194** is a portion. The interatrial septum **194**, comprised of the fossa ovalis **196** and muscular tissue **198**, separates the right atrium **190** and the left atrium **200**. Once the optical array **44** at the distal region of the catheter **42** is in the right atrium **190**, the catheter may be guided such that the optical array **44** abuts the interatrial wall. The distal portion of the catheter moves about the interatrial wall of the right atrium **190** as the optical array **44** emits light and detects the absorption spectra of the tissue(s) it encounters. When an absorption spectrum consistent with the fossa ovalis **196**, such as the spectrum **197** in FIG. **10**, the catheter **42** may remain in that location while the fossa ovalis **196** is punctured.

[0050] FIG. **10** shows the spectra observed by the optical array **44** when it encounters different tissues within the heart. The spectrum **191** characteristic of deoxygenated blood may be observed by the optical array **44** while traveling through the vena cava and into the right atrium. The spectrum **201** is the absorption spectra of the oxygenated blood of the left atrium. The spectrum **197** may be observed when the optical array **44** abuts the fossa ovalis and is an attenuated version of the oxygenated blood spectrum **201**. The fossa ovalis spec-

trum **197** has the negative curvature and increased remittance between 600 nm and 805 nm found in the spectrum **201**, but the remittance may be lowered across the length of the spectrum, resulting from travel through the fossa ovalis **196**. Actual spectra observed at a fossa ovalis may be more or less attenuated than spectrum **197** shown here, but may generally retain the curvature and slope of oxygenated blood. Muscular tissue may generally have a spectrum similar to spectrum **199**, reflecting a substantial amount of light directed at it.

[0051] Referring now to FIG. **11**, the optical array **44** abuts against a location **202** on the interatrial septum **194**. The location **202** includes both the muscular tissue **198** and the fibrous fossa ovalis **196**. The depth of penetration **64** may be located within the muscular tissue **198** and the spectra detected by the receiver **58** may be indicative of muscular tissue, similar to the spectrum **199** in FIG. **10**. The depth of penetration **66**, however, may be located in the left atrium **200** and therefore the spectrum detected by the receiver **60** may be similar to an attenuated left atrium blood spectra similar to the spectrum **197** in FIG. **10**, indicating the fossa ovalis. The absorption spectrum detected by the receiver **60** may be weak as most of the light may be unable to penetrate the muscular tissue **198**. The receivers do not both detect a spectrum indicating the fossa ovalis, indicating that the optical array **44** likely does not completely abut the fossa ovalis **196**. The optical array **44** may then be repositioned in a new location in order to determine whether a location exists at which both receivers detect spectra similar to the spectrum **197** indicative of the fossa ovalis.

[0052] Referring now to FIG. **12**, the optical array **44** abuts against a location **204** on the fossa ovalis **196**. As a result, both depths of penetration **64** and **66** are within the left atrium **200** and therefore both receivers **58** and **60** detect spectra having the characteristics of oxygenated blood similar to the spectrum **197** and **201** in FIG. **10**, indicative of the fossa ovalis **196**. By moving the optical array **44** across the atrial wall as shown in FIGS. **11** and **12**, the fossa ovalis **196** may be accurately localized. The change in spectra observed by the receivers is not instantaneous, but rather the spectra change slowly as the optical array is moved across the interatrial septum. The optical array **44** may therefore be moved about the interatrial septum until a spectrum is observed by all of the receivers that has the most similarity to the spectrum **201** of oxygenated blood, and may appear similar to the attenuated fossa ovalis spectrum **197**.

[0053] FIG. **13** shows the optical array **44** in contact with a relatively thick fossa ovalis **206**. The thicknesses of fossa ovalis vary significantly between individuals. When an optical array **44** encounters a thick fossa ovalis **206**, the light reflected from the depth of penetration **64** may not be within the left atrium **208**. As a result, the spectrum of light detected by the receiver **58** may be relatively flat and similar to the spectrum **199** in FIG. **10**, inconsistent with the fossa ovalis. Were the receiver **58** the only receiver, then the fossa ovalis **180** may not be localized. However, the receiver **60** has a greater depth of penetration **66**, allowing it to detect the blood of the left atrium **208**. As a result, the receiver **60** detects a spectrum similar to that of the spectrum **197** in FIG. **10**, indicating the fossa ovalis. The optical array **44**, by including two or more receivers, allows an operator to determine the presence of the fossa ovalis **206** despite its relative thickness. As an example, the measurements of the spectra may be similar or comparable to a weighted average between spectra **36** and **32**, with weighting biased more towards spectra **32** for receiver **60**, and

the net spectra approaching that of **32** as the ratio of spacing over thickness increases. Due to the non-discrete nature and range of potential thicknesses of the fossa ovalis (or other targeted tissue), a clinically established threshold may be used to differentiate.

[0054] Referring now to FIG. **14**, the optical array **82** of medical device **80** in FIG. **5** has four receivers, each a different distance from the emitter **84**. The receiver **86** has a depth of penetration **210**. The receiver **88** has a depth of penetration **212**. The receiver **90** has a depth of penetration **214**. The receiver **92** has a depth of penetration **216**. This arrangement of receivers allows a determination of the thickness of the fossa ovalis **218**. The receivers **86** and **88** have depths of penetration **210** and **212** that may be less than the thickness of the fossa ovalis **218** in this example and will thus detect spectra similar to the spectrum **199** of FIG. **10**. The receivers **90** and **92**, on the other hand, have depths of penetration **214** and **216** that may be greater than the thickness of the fossa ovalis **218** and may detect spectra more similar to the spectrum **197** of FIG. **10**. From this, an operator may determine that the thickness of the fossa ovalis **218** may be greater than the depth of penetration **212** but less than the depth of penetration **214**. Knowledge of the thickness of the fossa ovalis **218** may be beneficial in allowing an operator to estimate the amount of force that must be applied to a puncturing instrument. By applying a correct amount of force to the puncturing instrument, the possibility of using too much force and damaging tissue within the left atrium is minimized.

[0055] Because the actual spectra observed may not be as clearly distinct as the spectra **191**, **197** and **199** shown in FIG. **10**, various algorithms may be used to estimate that actual thickness of the fossa ovalis. That is, the spectra observed by receiver **88** and receiver **90** may have more subtle differences than the clear differences between spectra **197** and **199**. Empirically obtained data may be used to compare to actual data obtained using the optical array in order to accurately determine the thickness of a fossa ovalis. One such example of determining the desired location may include estimating the thickness of the fossa ovalis wall based on a projection from 1 or more measurements in conjunction with clinically measured empirical data. For example, the equation $S_m = (1-f) \times S_{fo} + f \times S_{la}$ may be used to approximate the location and spectra characteristics, where “ S_m ” is the measured spectra, “ S_{fo} ” is an empirically determined characteristic spectrum of the fossa ovalis when the separation distance is less than half the fossa ovalis thickness, and “ S_{la} ” is the spectrum characteristic of the left atrium when the probe is in pure left atrium blood or the separation distance is several times greater than the fossa ovalis thickness. “ f ” is a scaling factor in the range of 0 to 1. Given “ S_m ” and predetermined clinical “ S_{fo} ” and “ S_{la} ” (for each separation distance), we may solve for “ f ,” which may be empirically correlated to wall thickness for a given probe design and separation distance. A series of “ f ” values (denoted “ f_i ”) corresponding to multiple separation distances can improve the confidence in the thickness estimate over broader ranges.

[0056] Due to potentially widely varying offset shifts in the spectra amplitude, this exemplary approach may require normalizing the spectra by a discrete wavelength such as the isobestic point, such that “ S_m ,” “ S_{fo} ,” “ S_{la} ” are each normalized by their respective values at wavelength of approximately 805 nm.

[0057] Multiple methods of analysis exist by which spectra detected may be characterized. For example, an optical array

may detect reflected light at two wavelengths, one between 600 and 805 nm and one between 805 and 1000 nm. Specifically, the optical array may detect light at wavelengths of 660 nm and 940 nm. Remittance for each wavelength is calculated by dividing the amplitude of light reflected by the amplitude of light emitted at each wavelength. As can be seen in FIG. **10**, deoxygenated blood absorbs more light between 600 nm and 805 nm, illustrated by the spectrum **30**, while oxygenated blood reflects more light in this band, illustrated by spectra **32** and **34**.

[0058] Oxygenated and deoxygenated blood share an isobestic point at 805 nm. At wavelengths above the isobestic point oxygenated and deoxygenated blood have similar but opposite spectral responses compared with the responses the within 600 to 805 nm range. Thus, by comparing the remittance values detected at 660 nm and **940**, for example by dividing the remittance at 660 nm by the remittance at 940 nm to generate a remittance ratio, the percentage of oxygen saturation of blood may be accurately determined. A high remittance ratio indicates oxygenated blood as detected. Such a reading may indicate that an optical array is proximate to the fossa ovalis.

[0059] The above described technique of normalizing reflectance at one characteristic wavelength using reflectance at an isobestic or constant wavelength may be used to identify regions within the body based upon blood oxygenation, but may also be used to identify any region or tissue(s) by characteristic wavelengths.

[0060] Other methods may be used to identify the characteristic spectra of different tissue(s) including blood. For example, the entire spectra between 600 nm and 1000 nm can be detected using the optical array and displayed on a screen for an operator to view. Alternatively, discrete wavelengths can be measured using either a broad band emission or emission only of the light to be detected.

[0061] For example, light at wavelengths between 700 and 800 nm may be detected. In this region, oxygenated left atrial blood exhibits a substantially constant negative slope, as shown in the spectra **197** and **201** in FIG. **10**. The muscle of the interatrial septum exhibits a flat spectrum in this region while deoxygenated, right atrial blood exhibits a zig-zag spectrum, dipping markedly at 760 nm. Thus, the fossa ovalis may be localized by identifying the region of the interatrial septum in the right atrium where an optical array reads a spectrum having a relatively constant, negative slope between 700 and 800 nm. The region of the atrial wall having the most negative slope in this wavelength range may be the fossa ovalis.

[0062] There are several known mathematical methods suitable for accurately identifying these different spectra. For another example, the spectra **197** and **201** in FIG. **10** are concave down in the range of 600 nm to 760 nm. Thus, these spectra have a negative second derivative, or curvature. As used herein, the term curvature refers to the second derivative of a line and is a measure of the rate at which the slope of a line changes over a range. The spectrum **191** has a relatively steady positive slope in this region, resulting in a curvature close to 0. A spectrometer connected to the optical array could first measure the remittance at three or more points in this range, calculate the slopes between adjacent points, and calculate the curvature. The fossa ovalis may be localized by identifying the region of the interatrial septum having the most negative curvature.

[0063] A spectrometer may perform some or all of these calculations on reflected light detected by a receiver to identify the region of the septum at which the most left atrial, oxygenated blood is detected. This region may generally be the fossa ovalis. Any of these above techniques may be used to identify different tissues of within the right atrium so that the fossa ovalis may be identified. Once the fossa ovalis is found, a piercing apparatus may be introduced so that one or more medical devices may enter the left atrium.

[0064] The optical arrays described above may be used to identify and characterize tissue(s) other than the anatomical localization of the fossa ovalis. For example, other tissues, both normal and those possessing inherent physiological and pathological conditions of interest, having characteristic spectra may be identified using the above methods and systems described. Identification and characterization of particular tissues adjacent to a medical device aid in a variety of medical procedures.

[0065] It will be appreciated by persons skilled in the art that the present invention is not limited to what has been particularly shown and described herein above. In addition, unless mention was made above to the contrary, it should be noted that all of the accompanying drawings are not to scale. A variety of modifications and variations are possible in light of the above teachings without departing from the scope and spirit of the invention, which is limited only by the following claims.

What is claimed is:

1. A medical device for identifying the location of a medical device within a patient's body comprising:
 - an intravascular catheter;
 - an optical array comprising a light emitter and a plurality of receivers for detecting reflected light, wherein two or more of the plurality of receivers are each positioned at different distances from the emitter; and
 - a spectrometer in communication with the emitter and the plurality of receivers.
2. The medical device of claim 1, wherein the optical array further comprises a face plate, wherein the emitter and each of the plurality of receivers are located on the face plate.
3. The medical device of claim 1, wherein the catheter further comprises a lumen and the face plate is annular and surrounds an opening to the lumen at a distal region of the catheter.
4. The medical device of claim 3, wherein the catheter has a longitudinal axis and the annular face plate lies in a plane that is substantially orthogonal to the longitudinal axis of the catheter.
5. The medical device of claim 4, wherein the emitter and plurality of receivers are positioned radially around the lumen on the face plate.
6. The medical device of claim 5, wherein the plurality of receivers comprises at least a first receiver, a second receiver, and a third receiver.
7. The medical device of claim 6, wherein the first receiver and the second receiver are located approximately 180° from each other on the annular face plate, and the emitter and the third receiver are located approximately 180° from each other, the first and second receivers each being located approximately 90° from the emitter and third receiver.
8. The medical device of claim 1, wherein the catheter comprises a lumen and the optical array is insertable into the lumen such that it protrudes from a distal region of the catheter.

9. The medical device of claim 1, wherein the plurality of receivers comprises two receivers.

10. The medical device of claim 1, wherein the optical array further comprises two face plates;

- wherein the emitter and the each of the plurality of receivers are each located on either of the two face plates, wherein the catheter further comprises a lumen; and,
- wherein the optical array is insertable into the lumen such that it protrudes from a distal region of the catheter.

11. A medical device for identifying the location of the medical device within a patient relative to the fossa ovalis comprising:

- an intravascular catheter having a distal portion, a proximal portion, and a lumen therebetween;

- an optical array, at least a portion of which being slidably disposed within the lumen of the catheter and at least a portion of which protruding a distance beyond the distal portion of the catheter, the optical array comprising a light emitter and a plurality of receivers for detecting reflected light, wherein each of the plurality of receivers is positioned at different distances from the emitter; and
- a spectrometer in communication with the emitter and the plurality of receivers.

12. The medical device of claim 11, wherein the optical array is expandable and collapsible, such that at least a portion of the optical array is receivable within the lumen of the catheter.

13. The medical device of claim 11, further comprising a first face plate and a second face plate.

14. The medical device of claim 13, wherein the intravascular catheter has a longitudinal axis and the first face plate and second face plate each lie in a plane that is substantially orthogonal to the longitudinal axis of the intravascular catheter.

15. The medical device of claim 14, wherein the plurality of receivers comprises a first receiver, a second receiver, and a third receiver.

16. The medical device of claim 15, wherein the emitter and the first receiver are located on the first face plate and the second receiver and the third receiver are located on the second face plate.

17. The medical device of claim 16, further comprising a radiopaque marker coupled to the optical array.

18. A medical device for identifying the location of the medical device within a patient relative to the fossa ovalis comprising:

- an intravascular catheter having a distal portion, a proximal portion, and a lumen therebetween;

- an expandable and collapsible optical array, at least a portion of the optical array being slidably disposed within the lumen of the catheter and at least a portion of the optical array protruding a distance beyond the distal portion of the catheter, the optical array comprising a light emitter, a first receiver, a second receiver, and a third receiver, each of which receivers for detecting reflected light, wherein each of the first, second, and third receivers is positioned at a different distance from the emitter than the other two receivers;

- a radiopaque marker coupled to the optical array; and
- a spectrometer in communication with the emitter and the first, second, and third receivers.

19. The medical device of claim 18, wherein the emitter, first receiver, second receiver, and third receiver all lie on the same plane.

20. The medical device of claim **19**, wherein the optical array further comprises a plurality of expanding arms, each of the emitter, first receiver, second receiver, and third receiver being coupled to an individual expanding arm.

21. A system for assessing an area of target tissue, comprising:

an intravascular catheter including a distal portion, a proximal portion, and a lumen therebetween, the intravascular catheter further comprising an optical array comprising a light emitter and a plurality of receivers for detecting reflected light, wherein at least two of the plurality of receivers are each positioned at different distances from the emitter; and

a spectrometer in communication with the emitter and the plurality of receivers.

22. The system of claim **21**, wherein the spectrometer includes one or more processors capable of analyzing optical data received from the plurality of receivers.

23. The system of claim **22**, wherein the one or more processors are capable of determining the depth of an area of target tissue based at least in part on the optical data received from one or more of the plurality of receivers.

24. The system of claim **22**, wherein the one or more processors are capable of assessing the suitability of an area of target tissue for a medical procedure.

25. The system of claim **24**, wherein the area of target tissue is a cardiac septum and the medical procedure is a trans-septal procedure.

26. The system of claim **25**, wherein the area of target tissue is the fossa ovalis.

* * * * *

专利名称(译)	用于识别患者体内设备位置的系统，用于定位卵圆窝以进行经中隔手术		
公开(公告)号	US20130116522A1	公开(公告)日	2013-05-09
申请号	US13/731162	申请日	2012-12-31
[标]申请(专利权)人(译)	麦德托尼克消融前沿有限公司		
当前申请(专利权)人(译)	美敦力公司消融FRONTIERS有限责任公司		
[标]发明人	CINBIS CAN SHEN XIAONAN KUHN JONATHAN		
发明人	CINBIS, CAN SHEN, XIAONAN KUHN, JONATHAN		
IPC分类号	A61B5/1459 A61B5/06 A61B5/00 A61B5/1455		
CPC分类号	A61B5/0075 A61B5/065 A61B5/1459 A61B5/4887 A61B19/54 A61B2017/00061 A61B2017/00243 A61B2019/5206 A61B2562/0242 A61B5/0044 A61B5/061 A61B5/064 A61B5/14552 A61B5/6852 A61B5/72 A61B5/0084 A61B90/39 A61B2090/306		
其他公开文献	US8923950		
外部链接	Espacenet USPTO		

摘要(译)

用于识别患者体内医疗装置的位置的系统和方法可用于定位卵圆窝以进行经中隔手术。该系统和方法测量由光学阵列遇到的组织反射的光。光学阵列检测与光学阵列距离不同的组织的特征波长。距光学阵列不同距离的不同波长的光的反射率可用于识别所遇到的组织类型，包括从右心房通过卵圆窝检测到的左心房中的含氧血液。

