



(19) **United States**

(12) **Patent Application Publication**

(10) **Pub. No.: US 2003/0191398 A1**

**Motz et al.**

(43) **Pub. Date:**

**Oct. 9, 2003**

(54) **SYSTEMS AND METHODS FOR SPECTROSCOPY OF BIOLOGICAL TISSUE**

**Publication Classification**

(75) Inventors: **Jason T. Motz**, Cambridge, MA (US);  
**Luis H. Galindo**, Fitchberg, MA (US);  
**Martin Hunter**, Belmont, MA (US);  
**Ramachandra Dasari**, Lexington, MA (US);  
**Michael S. Feld**, Newton, MA (US)

(51) **Int. Cl.<sup>7</sup>** ..... **A61B 6/00**  
(52) **U.S. Cl.** ..... **600/478**

(57) **ABSTRACT**

The system and method of the present invention relates to using spectroscopy, for example, Raman spectroscopic methods for diagnosis of tissue conditions such as vascular disease or cancer. In accordance with a preferred embodiment of the present invention, a system for measuring tissue includes a fiber optic probe having a proximal end, a distal end, and a diameter of 2 mm or less. This small diameter allows the system to be used for the diagnosis of coronary artery disease or other small lumens or soft tissue with minimal trauma. A delivery optical fiber is included in the probe coupled at the proximal end to a light source. A filter for the delivery fibers is included at the distal end. The system includes a collection optical fiber (or fibers) in the probe that collects Raman scattered radiation from tissue, the collection optical fiber is coupled at the proximal end to a detector. A second filter is disposed at the distal end of the collection fibers. An optical lens system is disposed at the distal end of the probe including a delivery waveguide coupled to the delivery fiber, a collection waveguide coupled to the collection fiber and a lens.

Correspondence Address:  
**THOMAS O. HOOVER, ESQ.**  
**BOWDITCH & DEWEY, LLP**  
161 Worcester Road  
P.O. Box 9320  
Framingham, MA 01701-9320 (US)

(73) Assignee: **Massachusetts Institute of Technology**,  
Cambridge, MA

(21) Appl. No.: **10/178,062**

(22) Filed: **Jun. 21, 2002**

**Related U.S. Application Data**

(60) Provisional application No. 60/370,197, filed on Apr. 5, 2002.

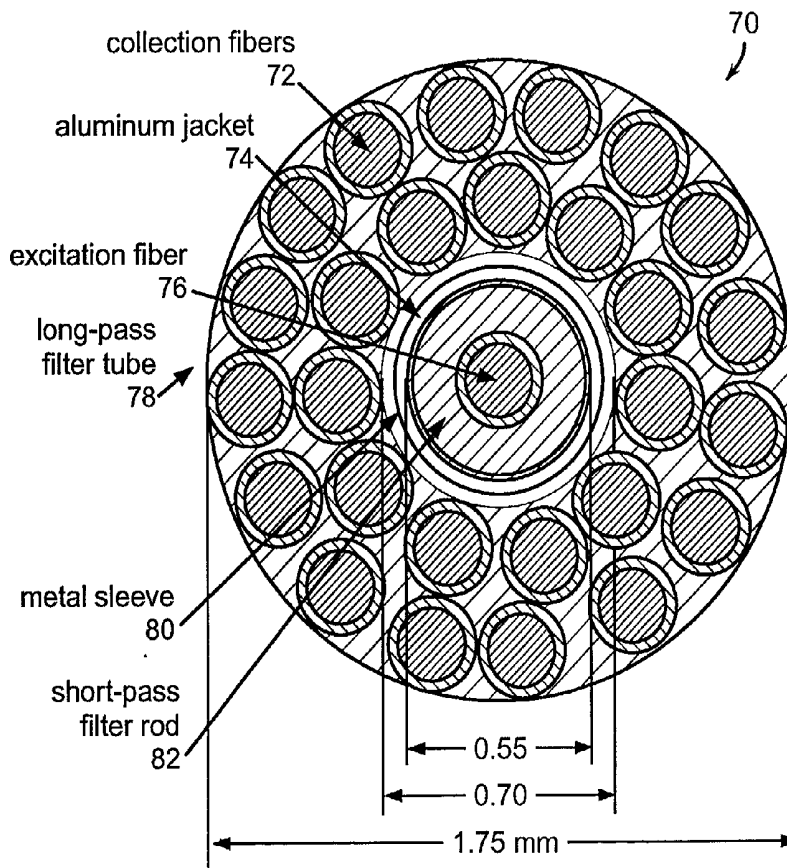

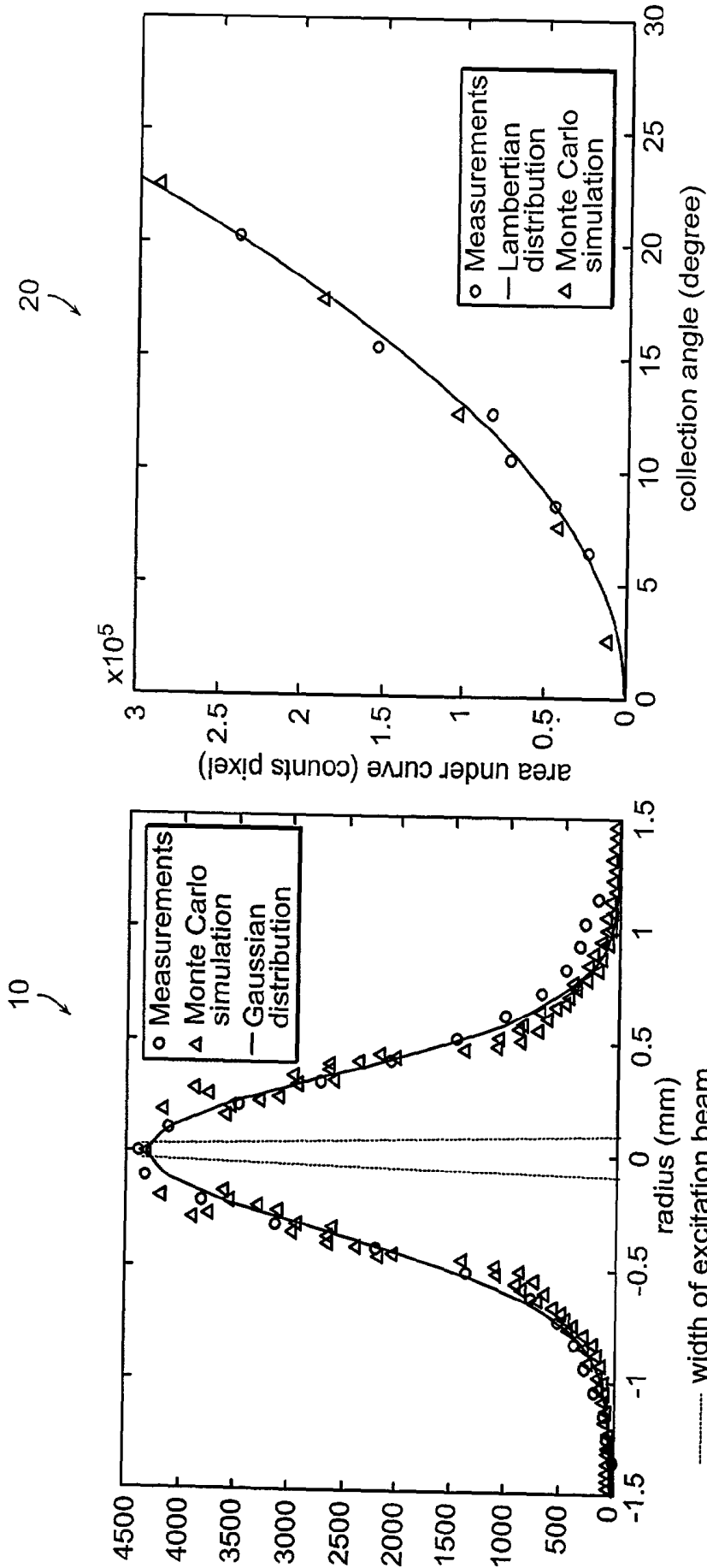

Figure 1A

Figure 1B

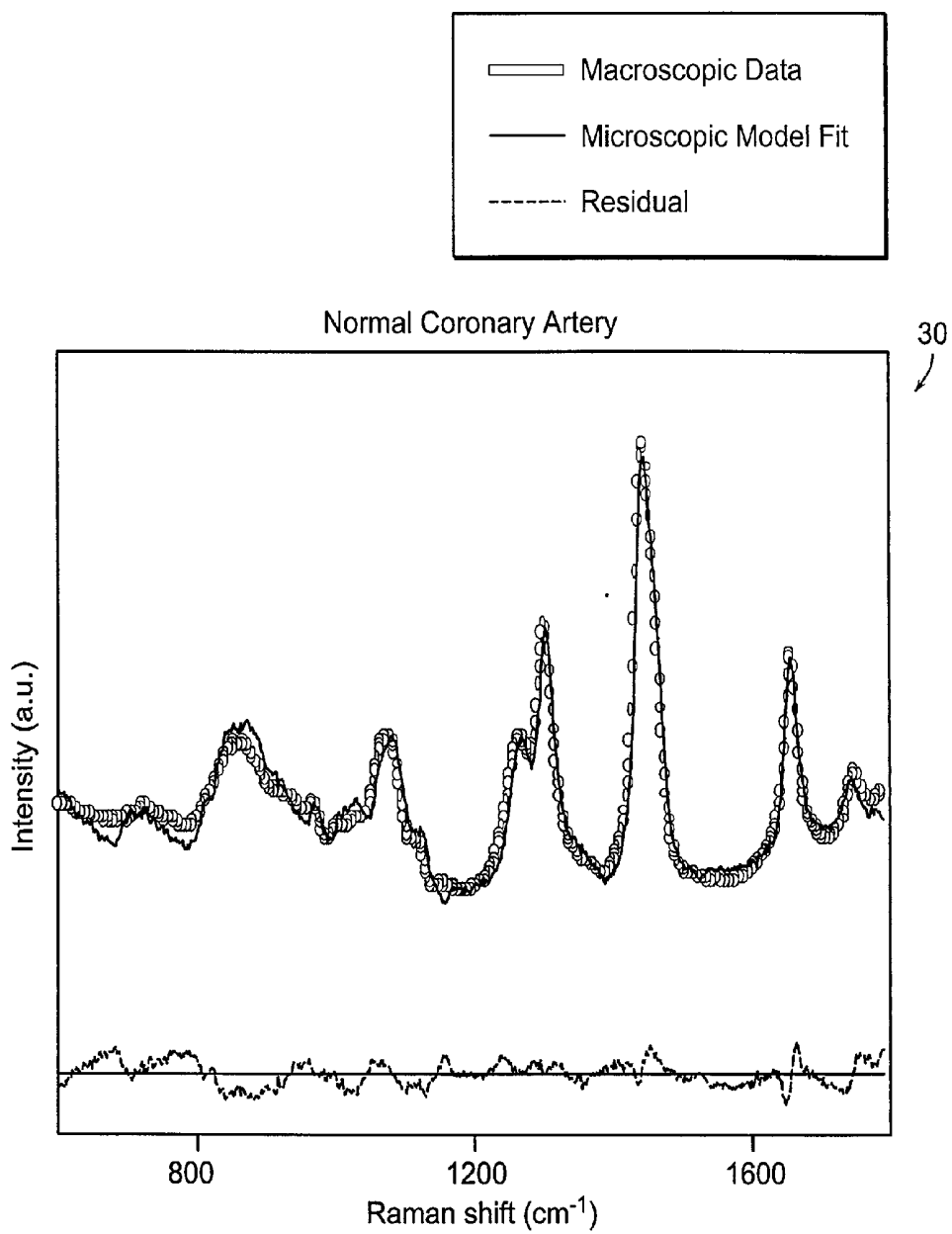

Figure 2A

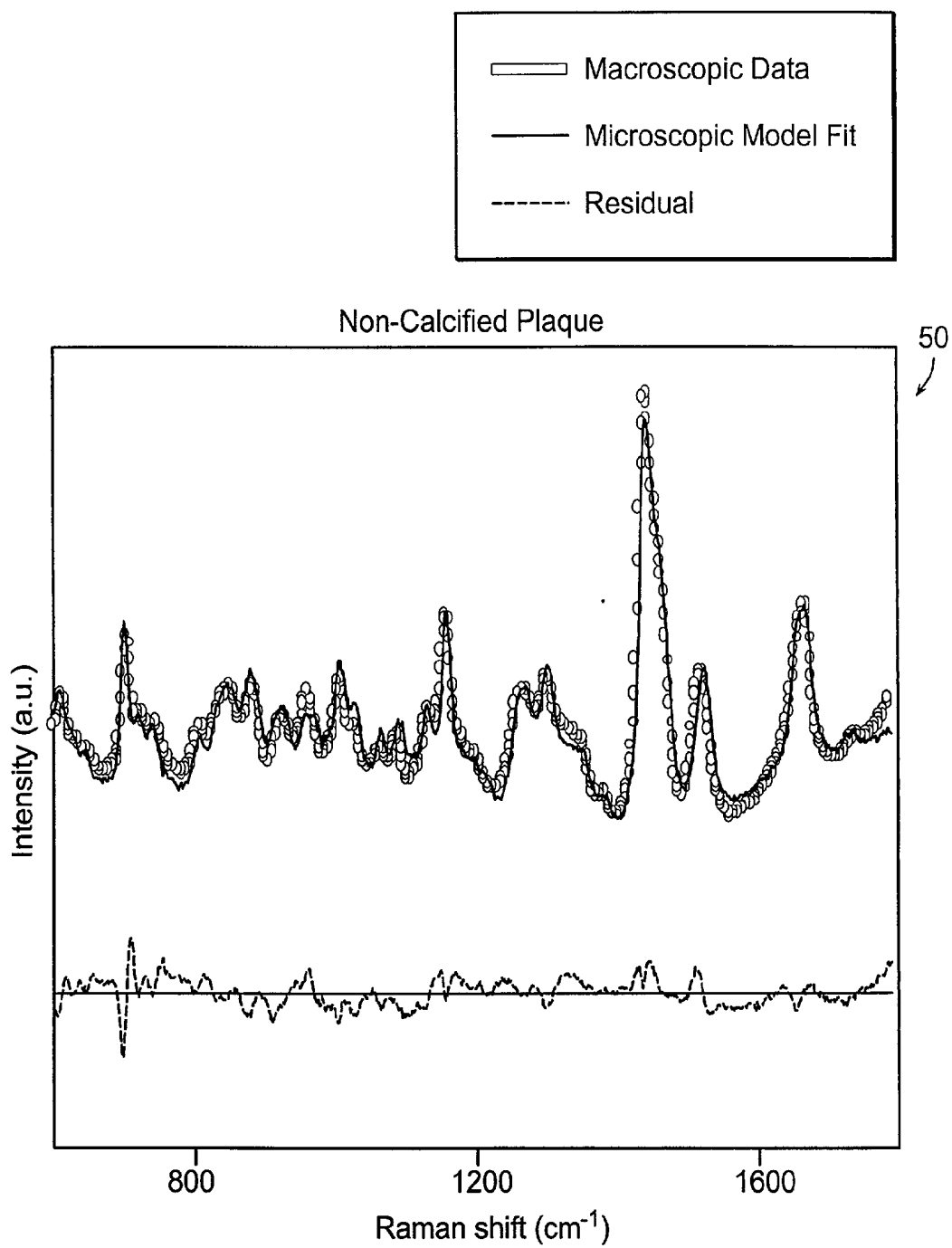

Figure 2B

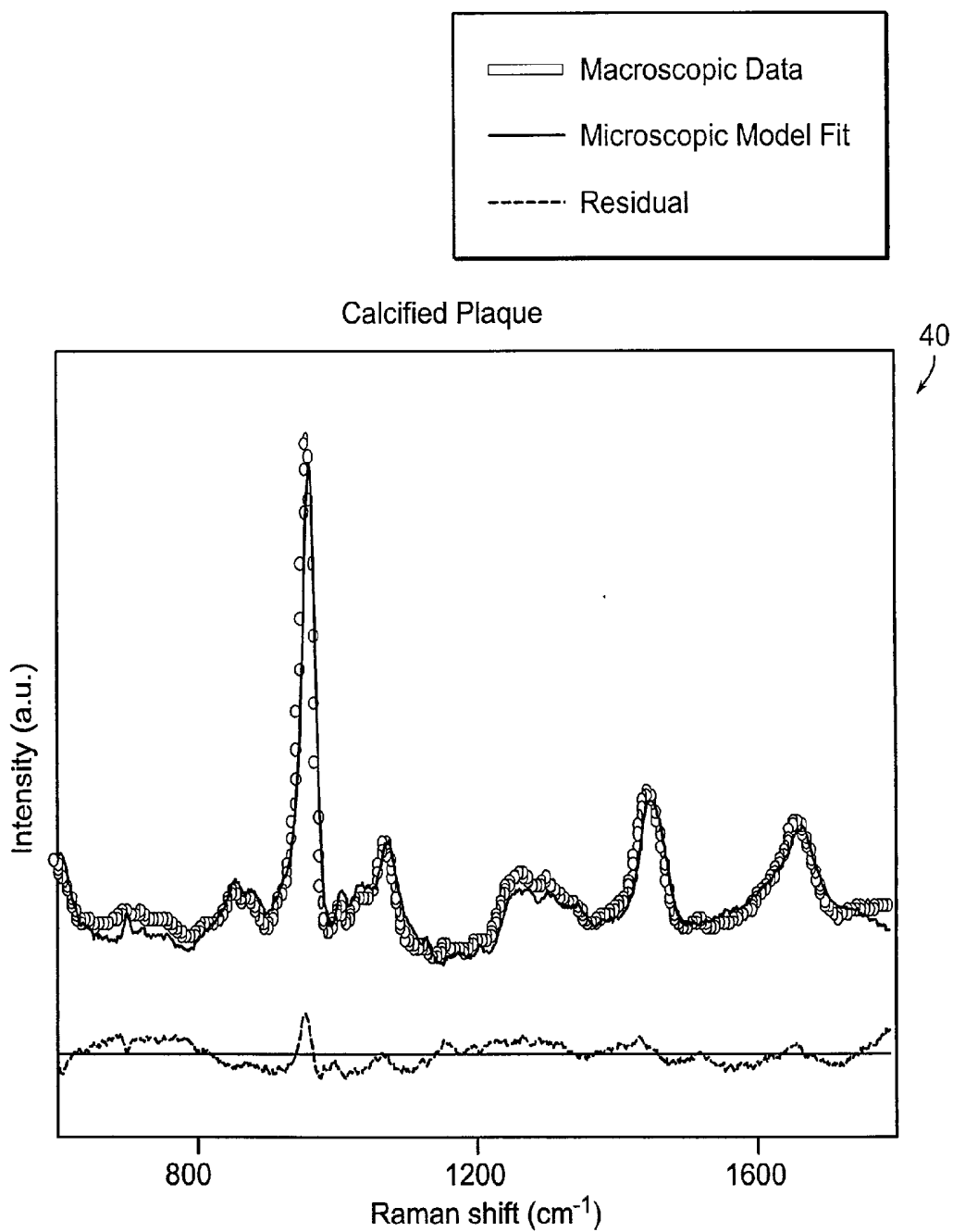

Figure 2C

60

Raman Morphometry of Coronary Artery

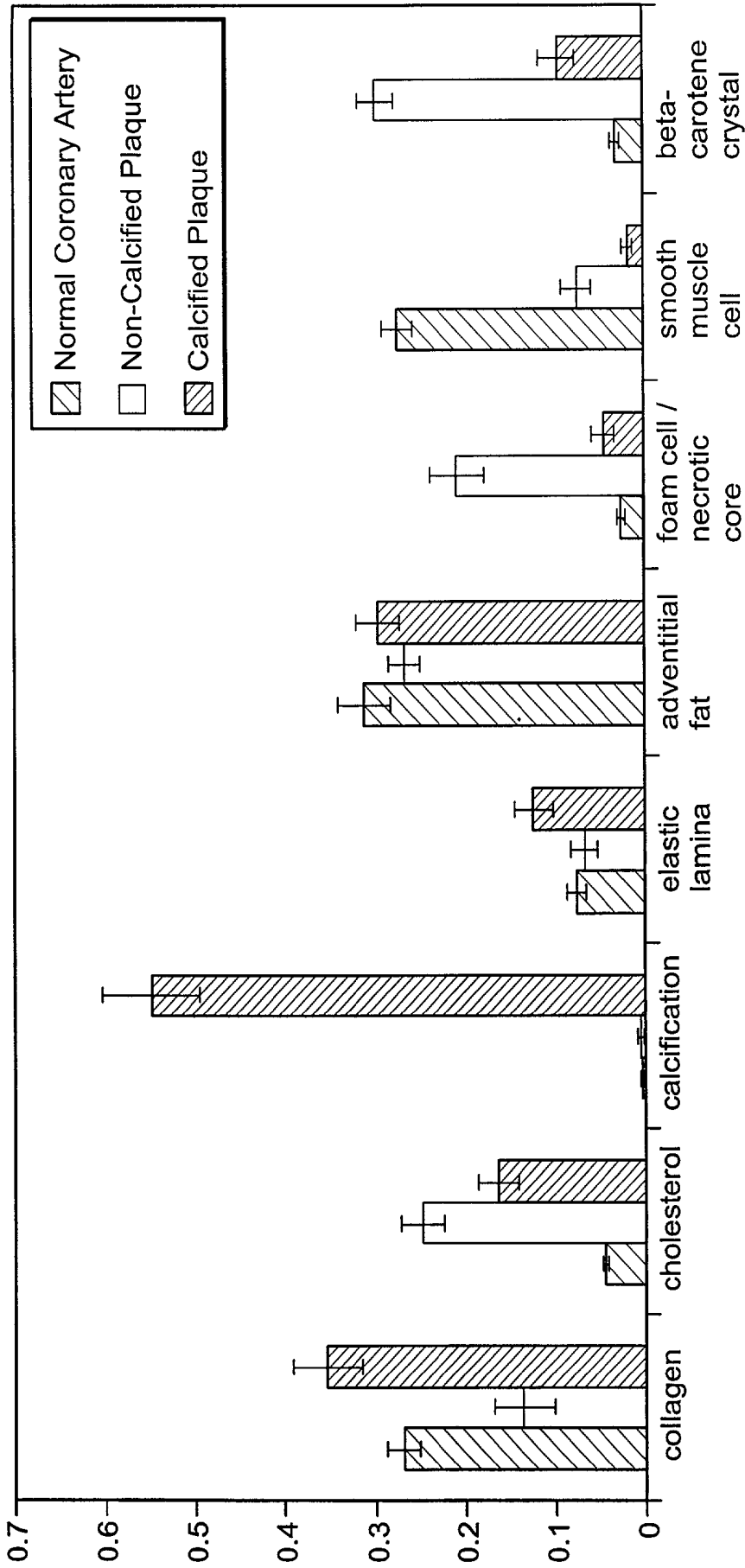

Figure 3

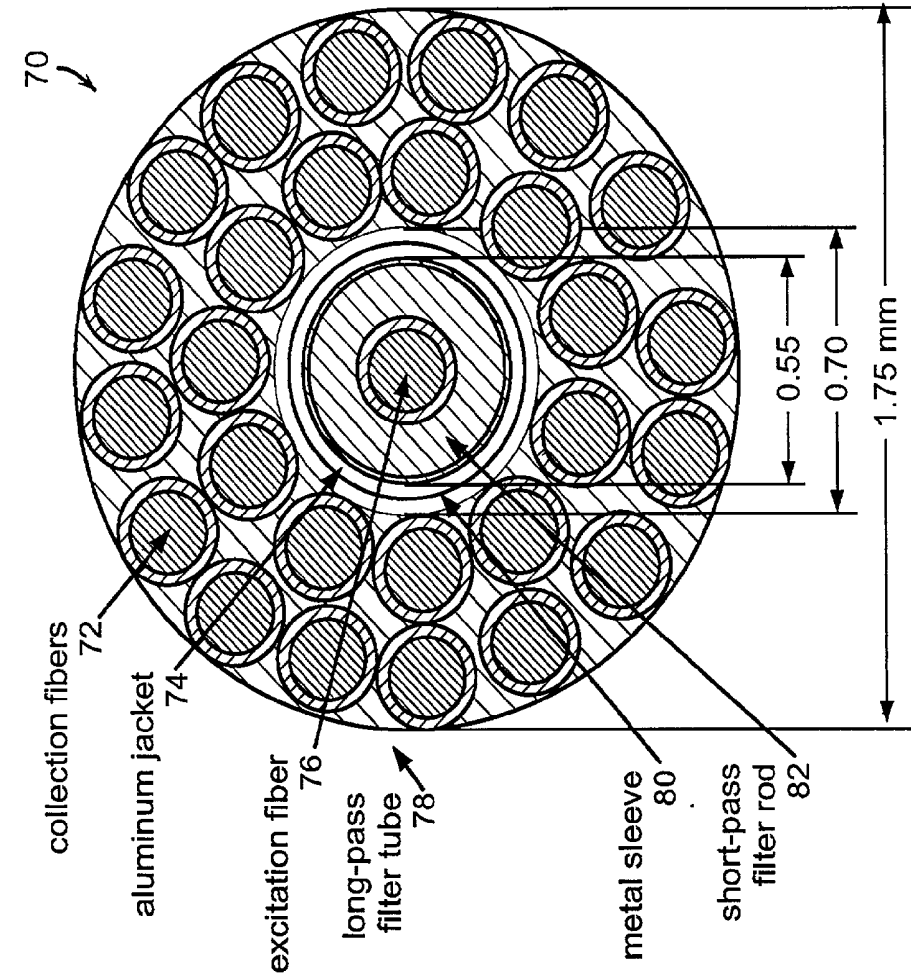

Figure 4B

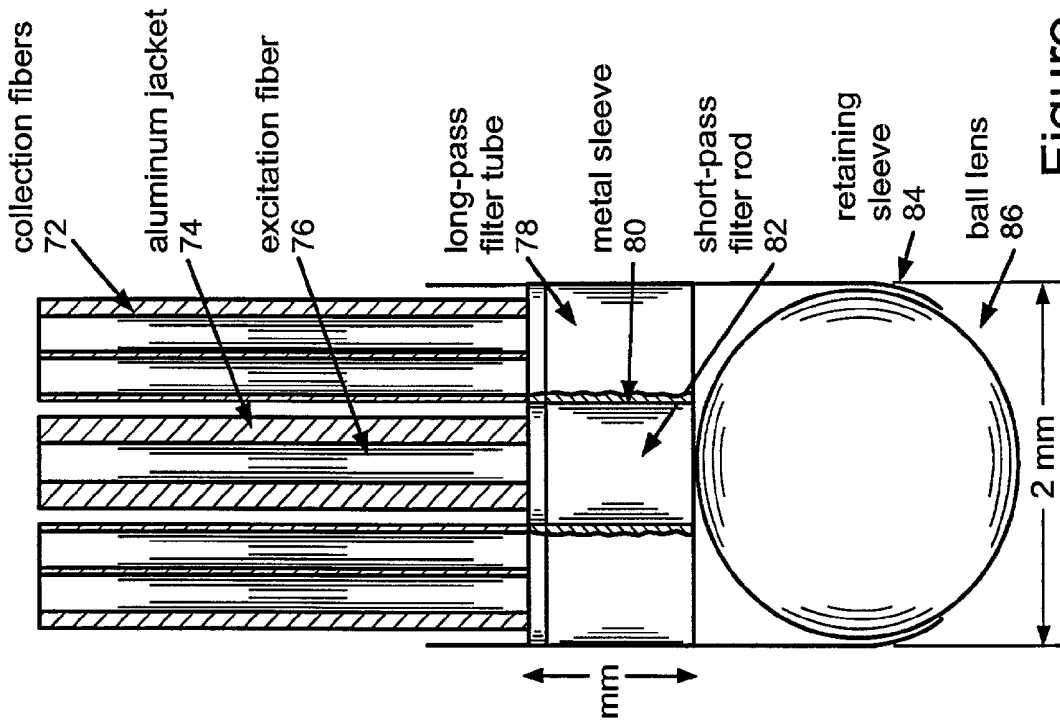

Figure 4A

100

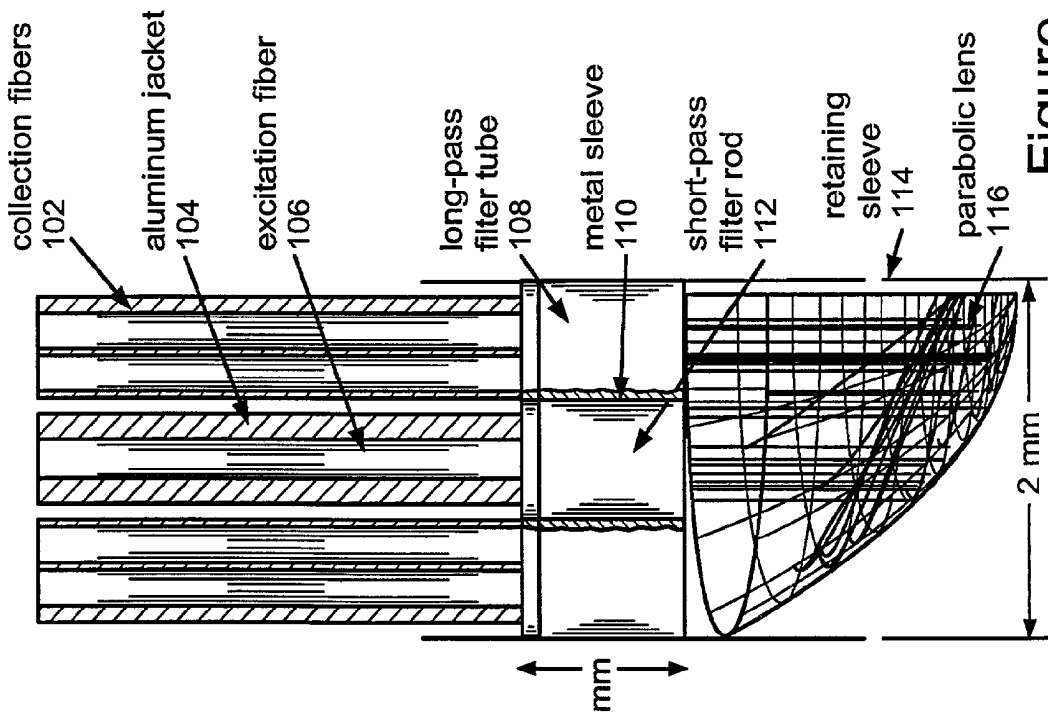

Figure 4C

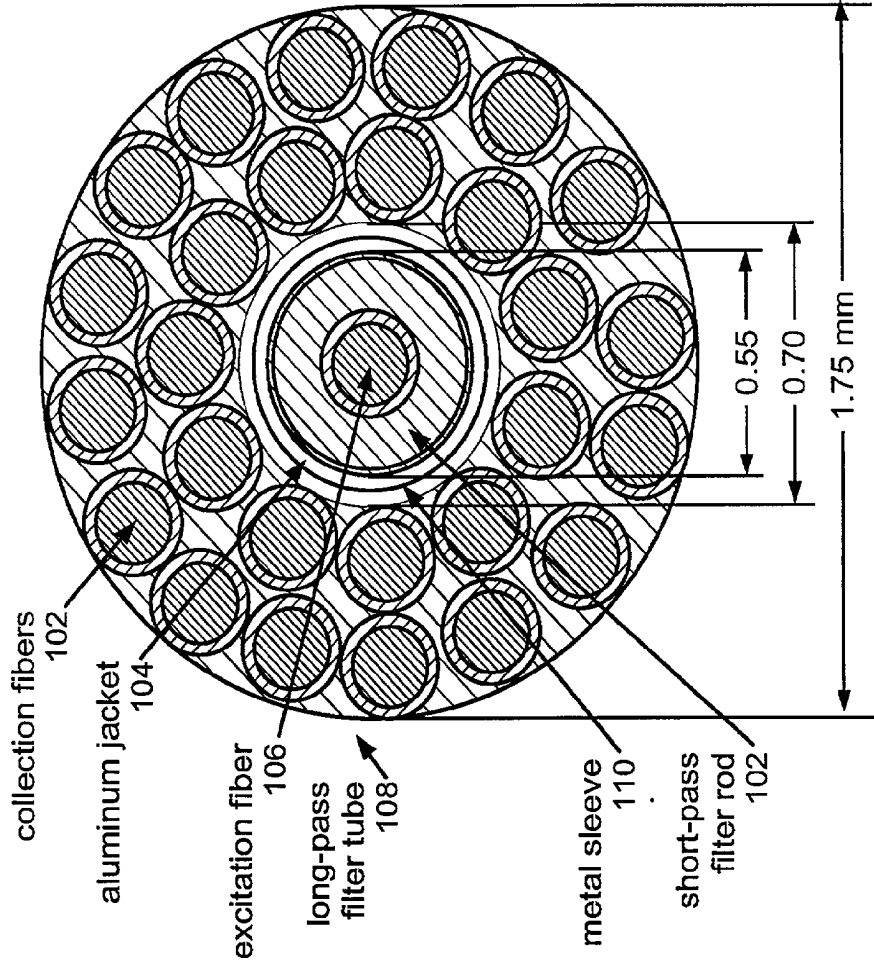

Figure 4D

140

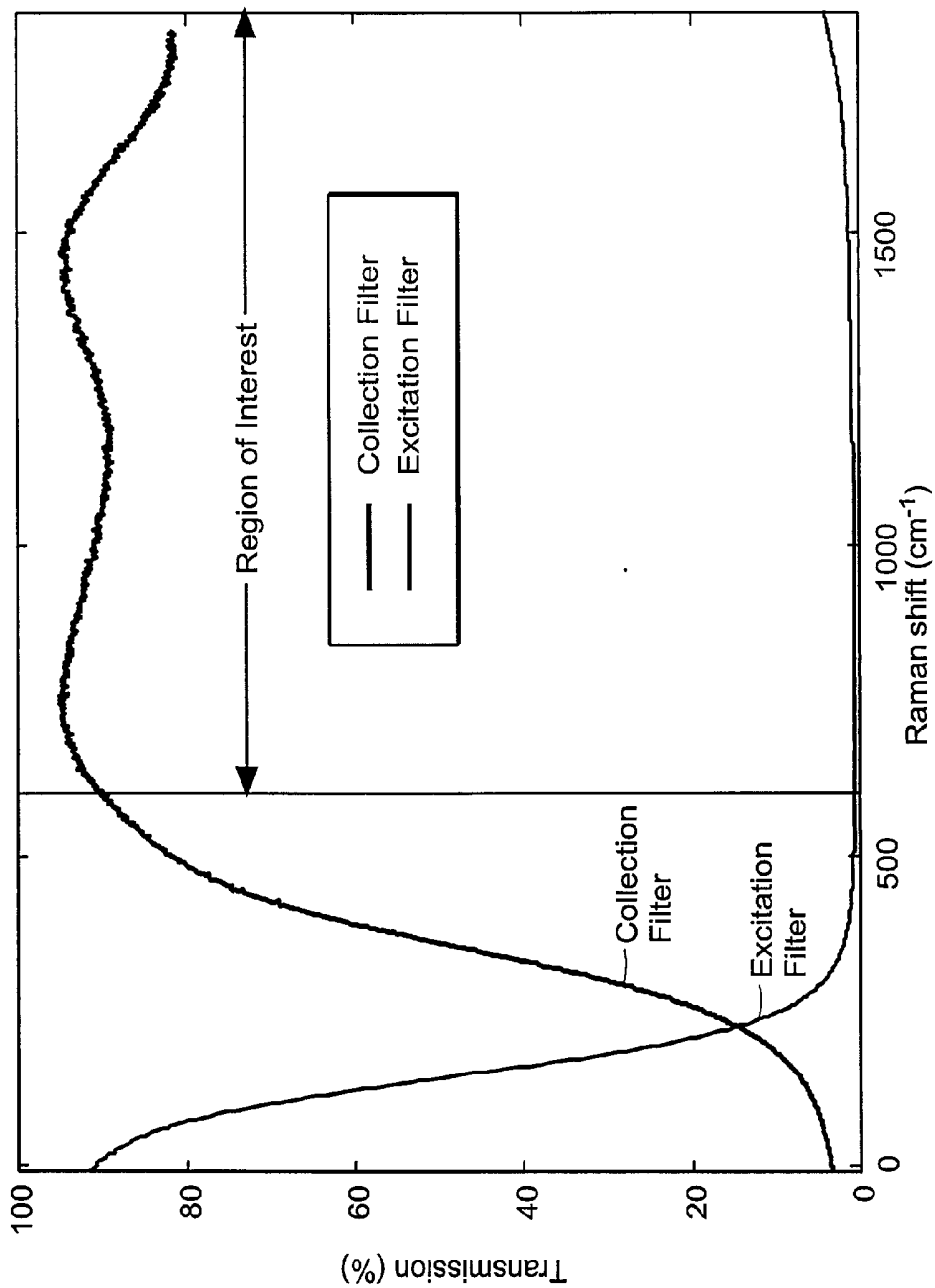

Figure 5

160

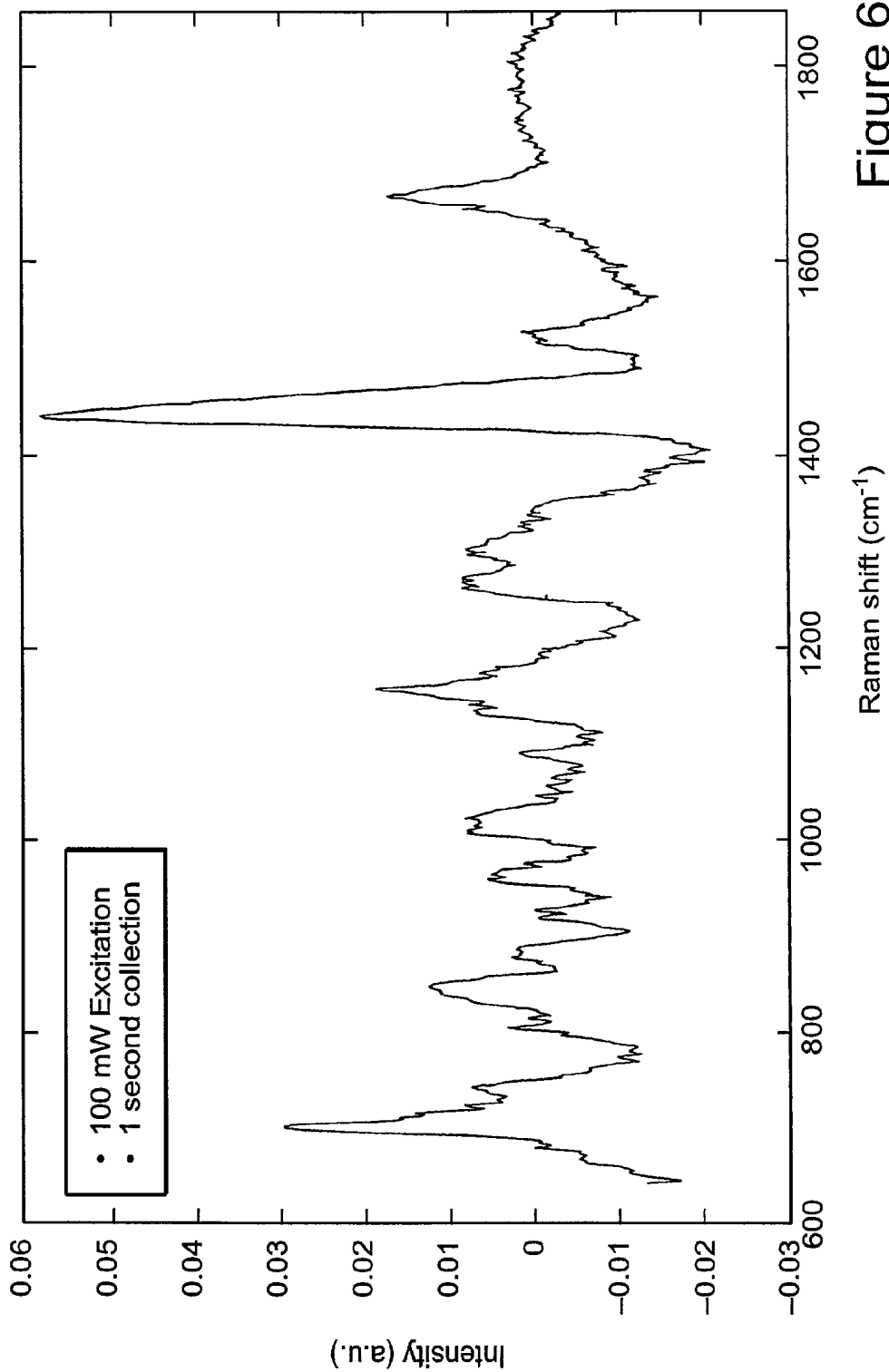

Figure 6

180

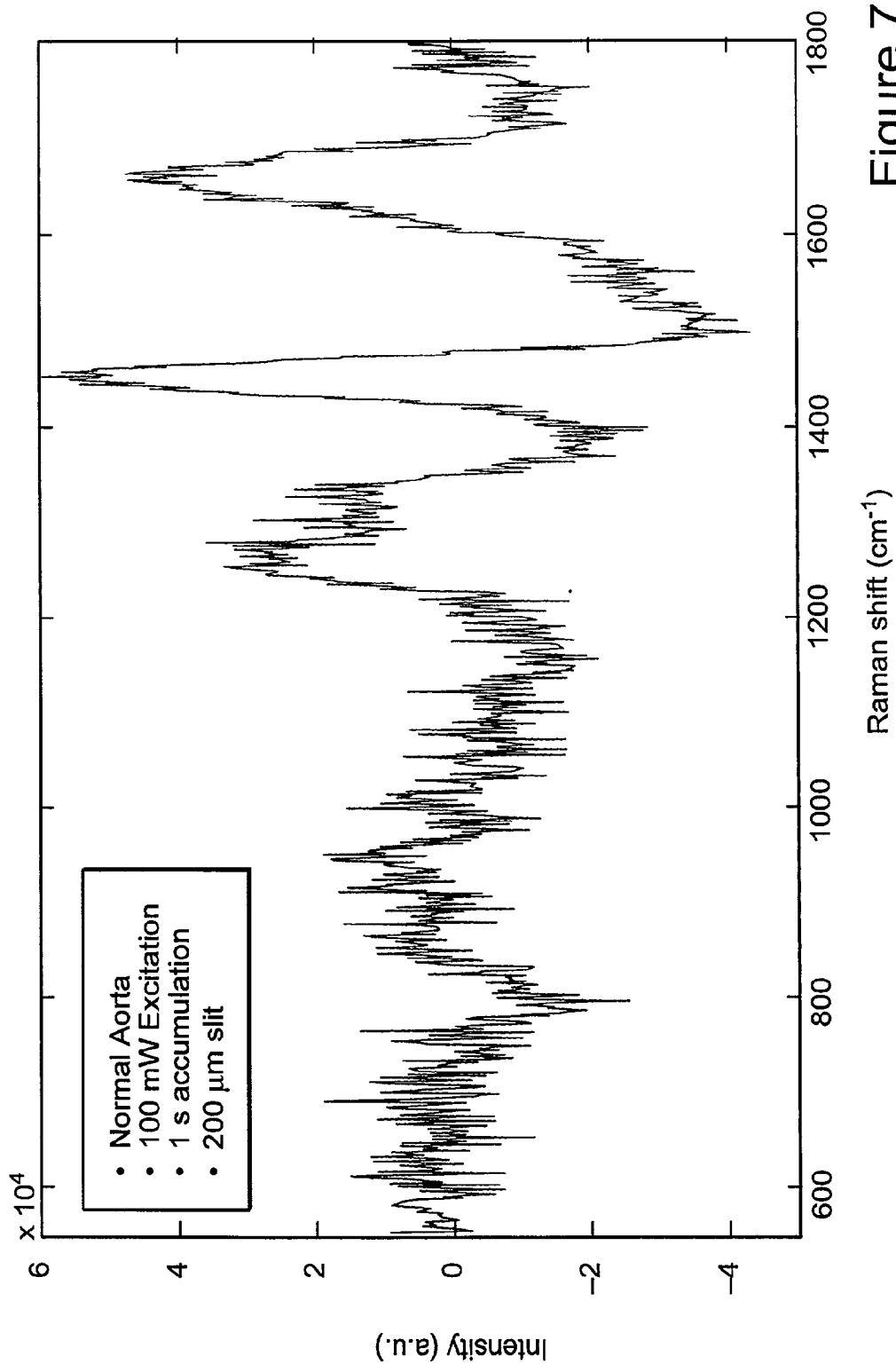

Figure 7

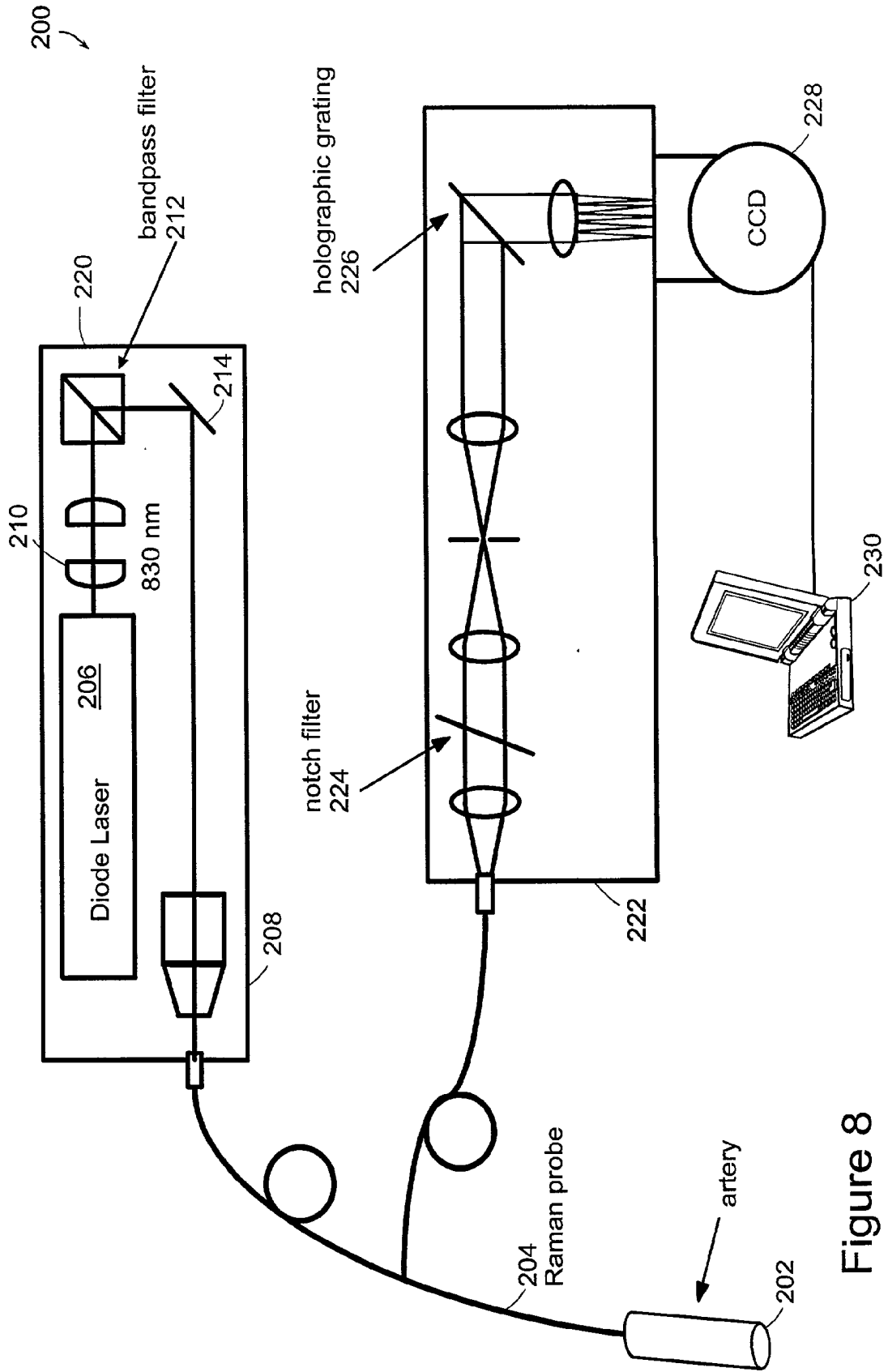

Figure 8

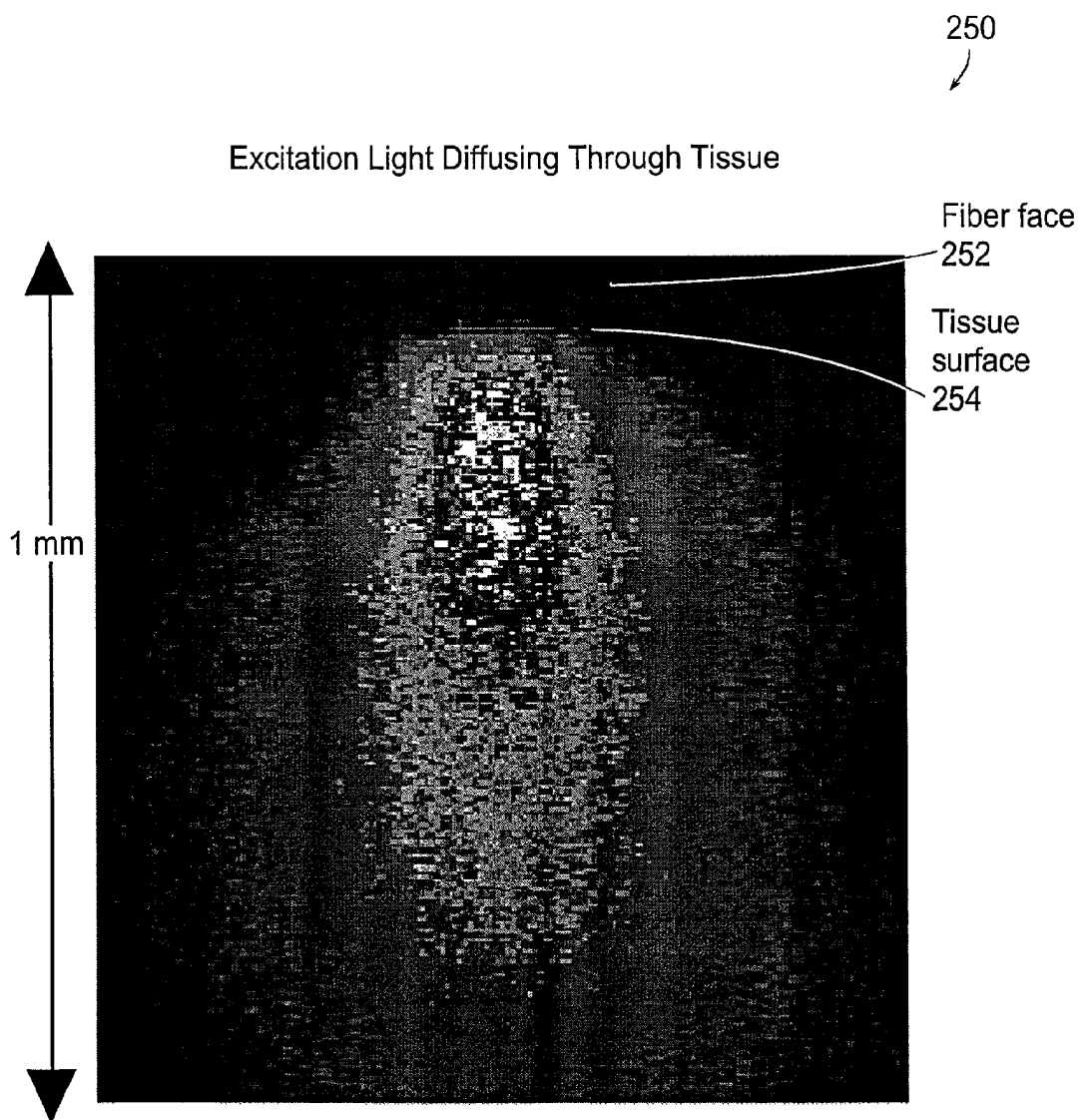

Figure 9

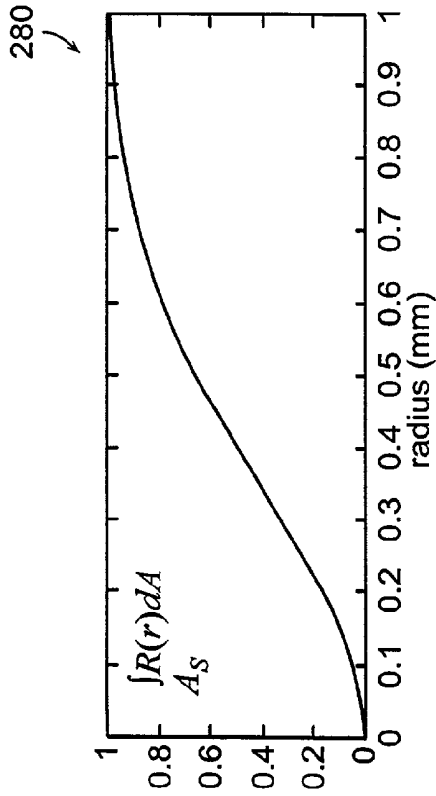

Figure 10A

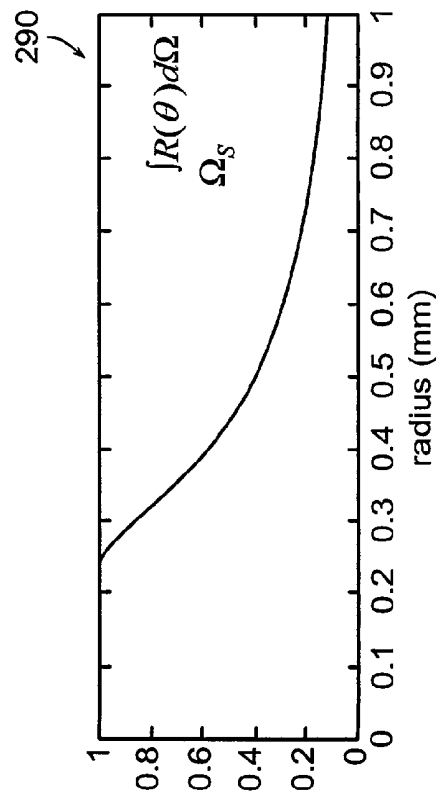

Figure 10B

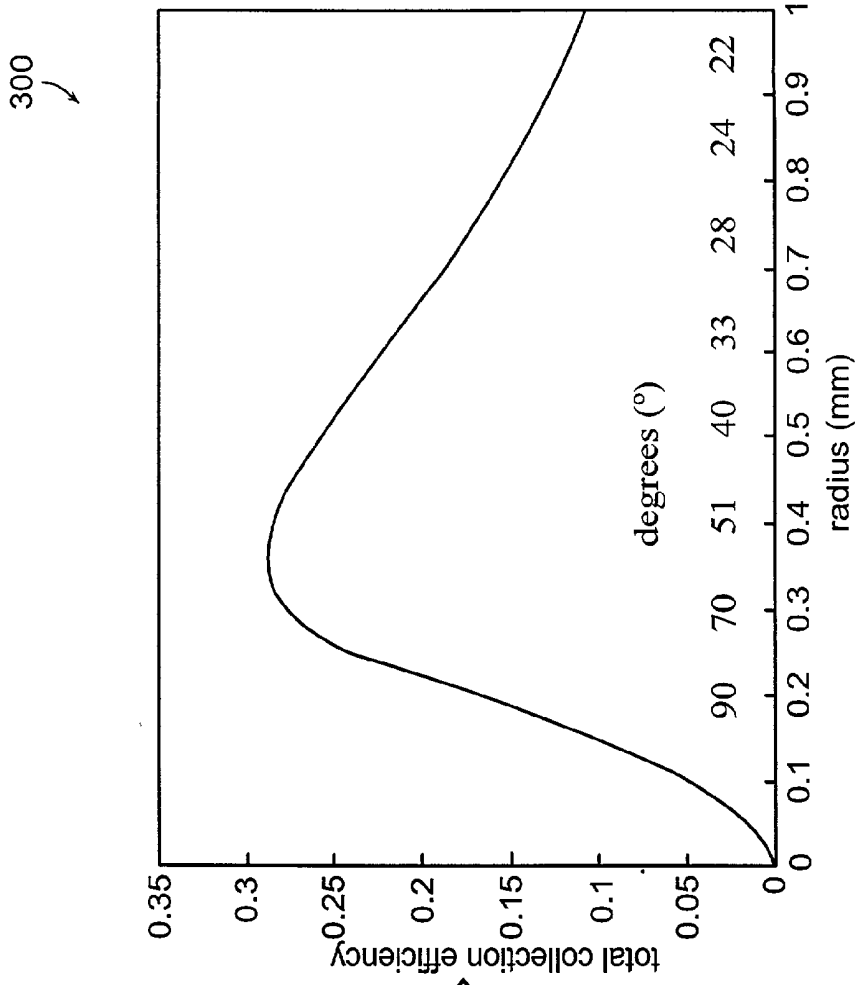

Figure 10C

300

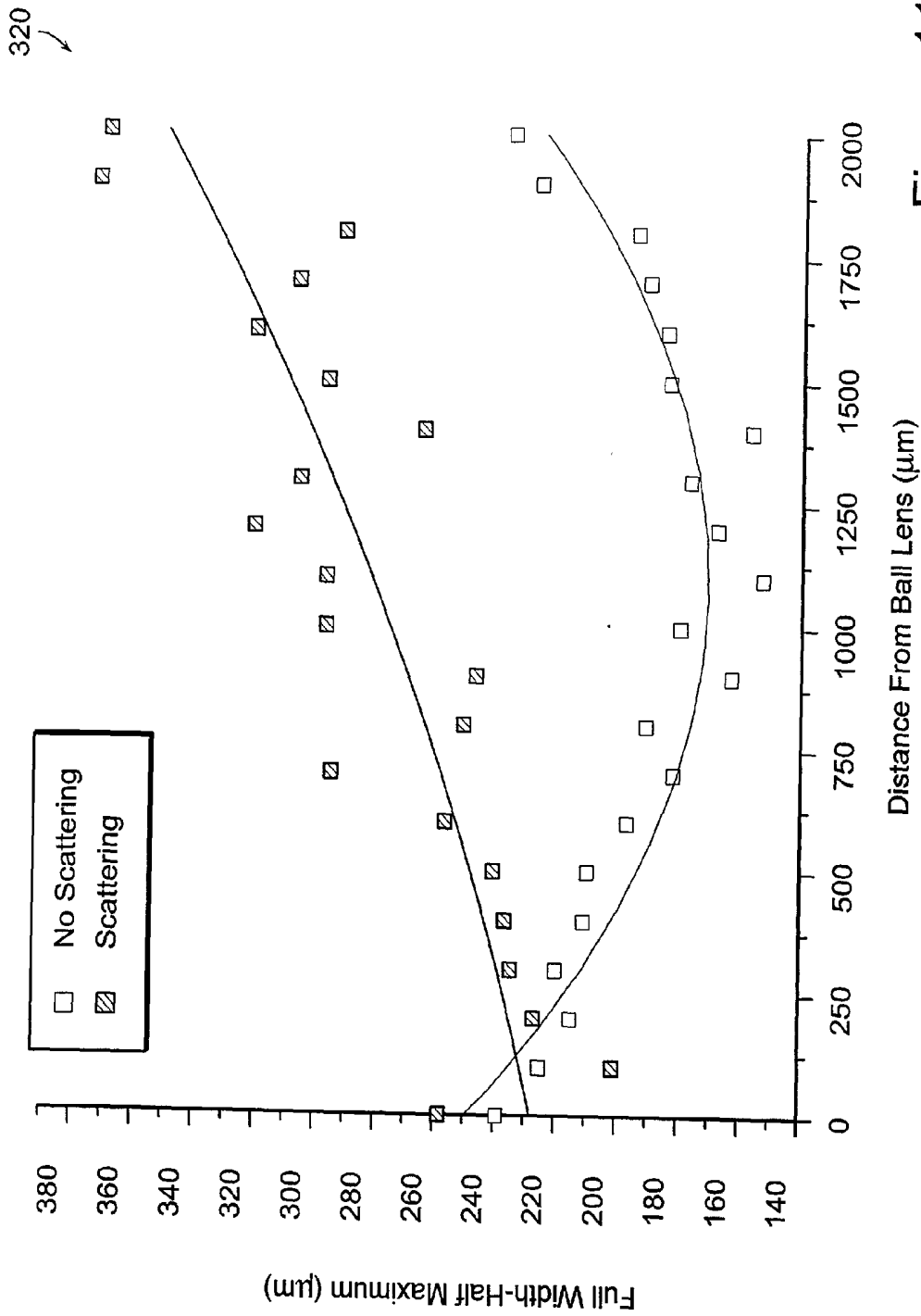

Figure 11

340

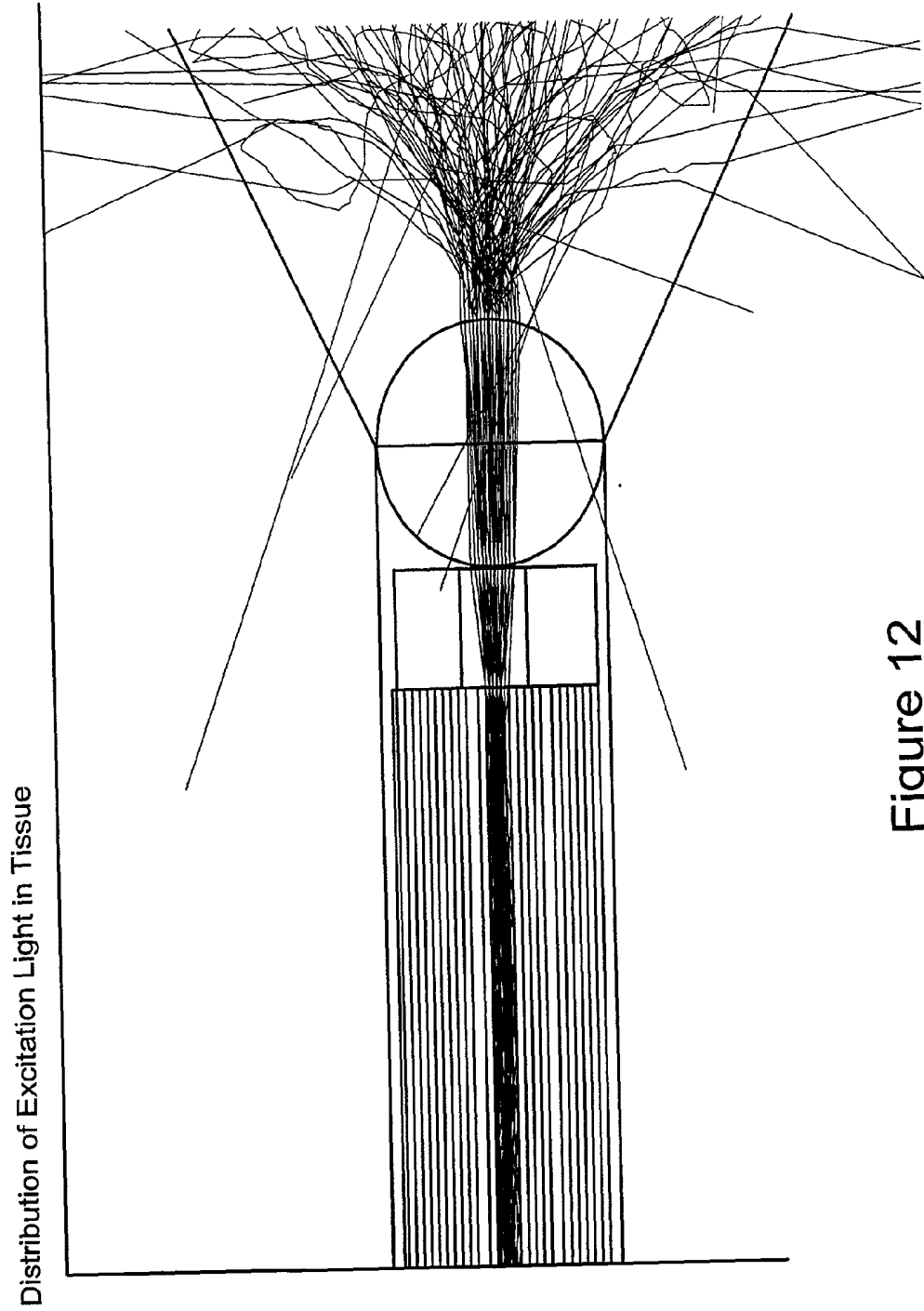

Figure 12

Collection Efficiency of the Raman Probe

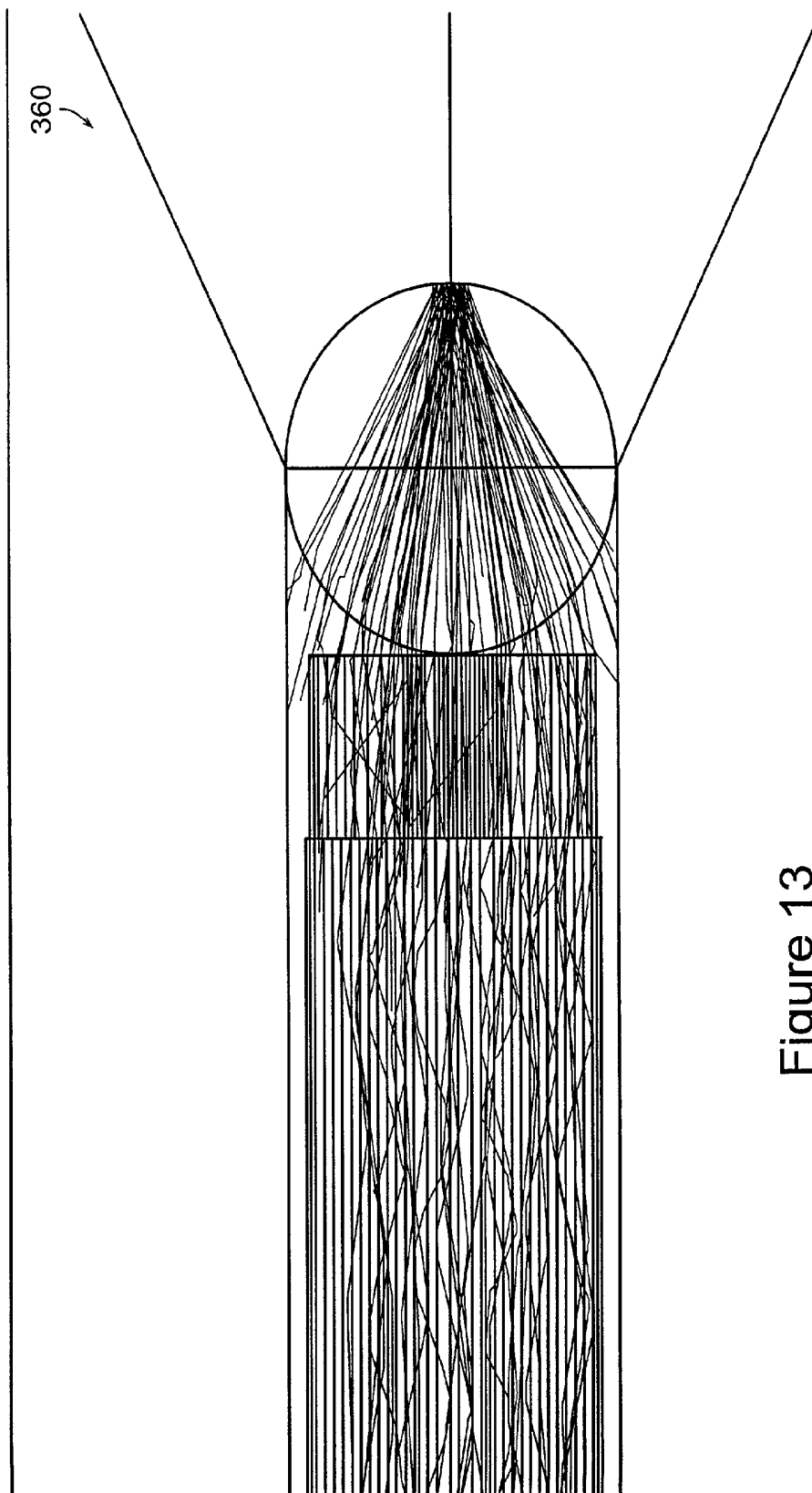

Figure 13

380 ↗

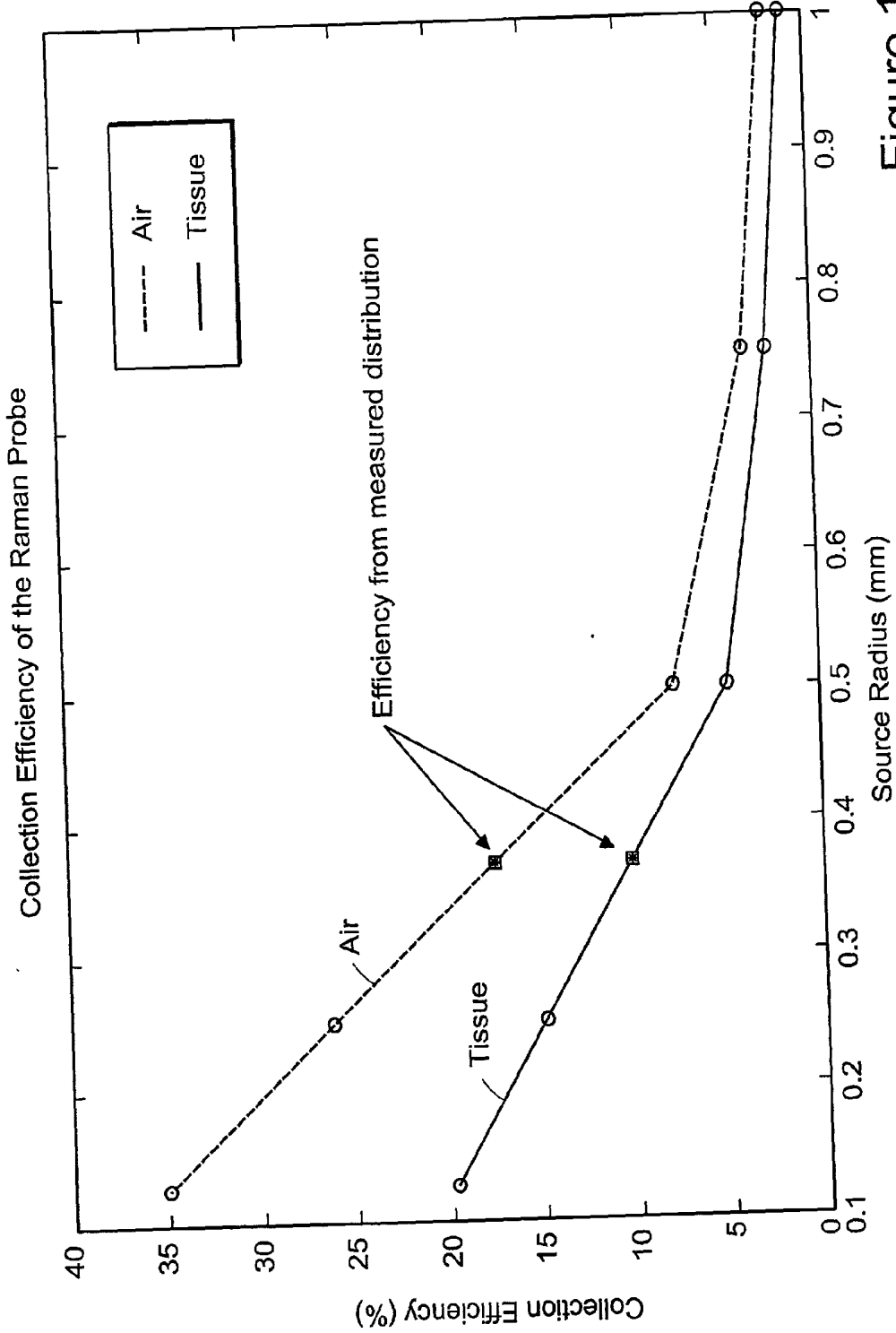

Figure 14

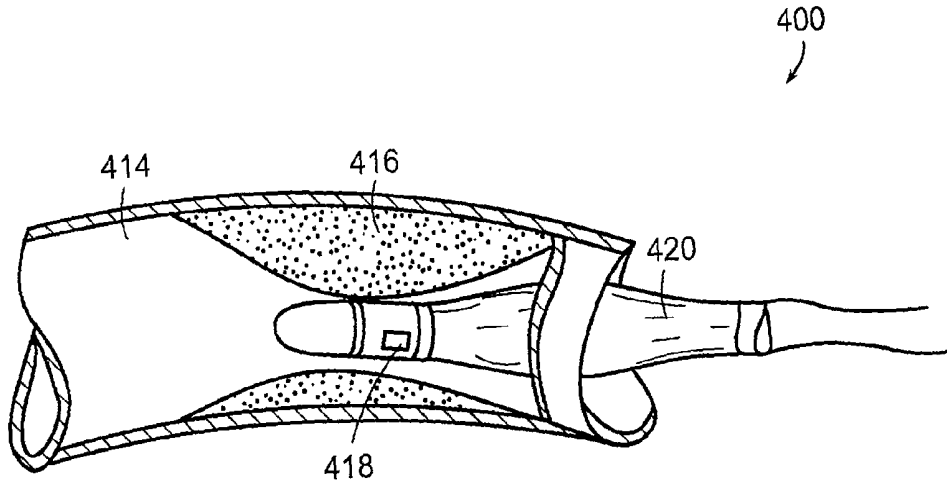

Figure 15

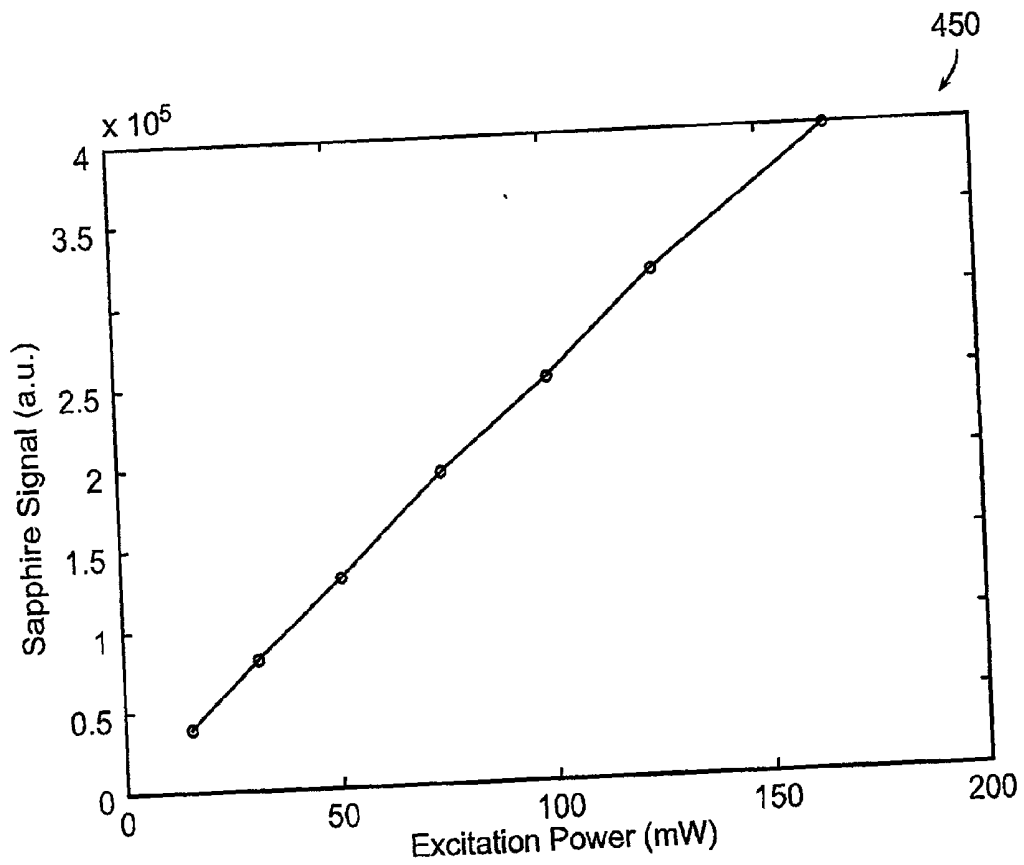

Figure 16

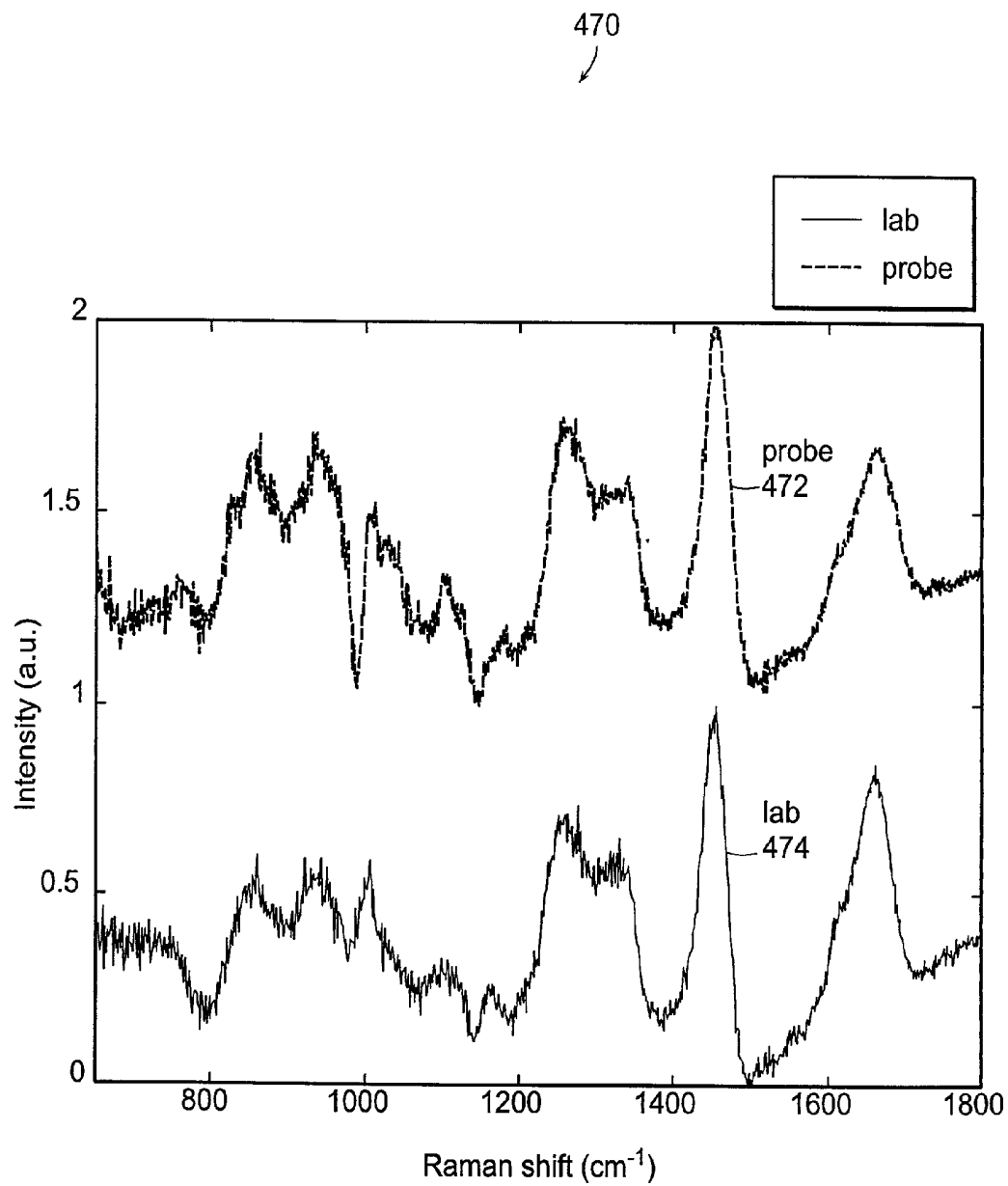

Figure 17

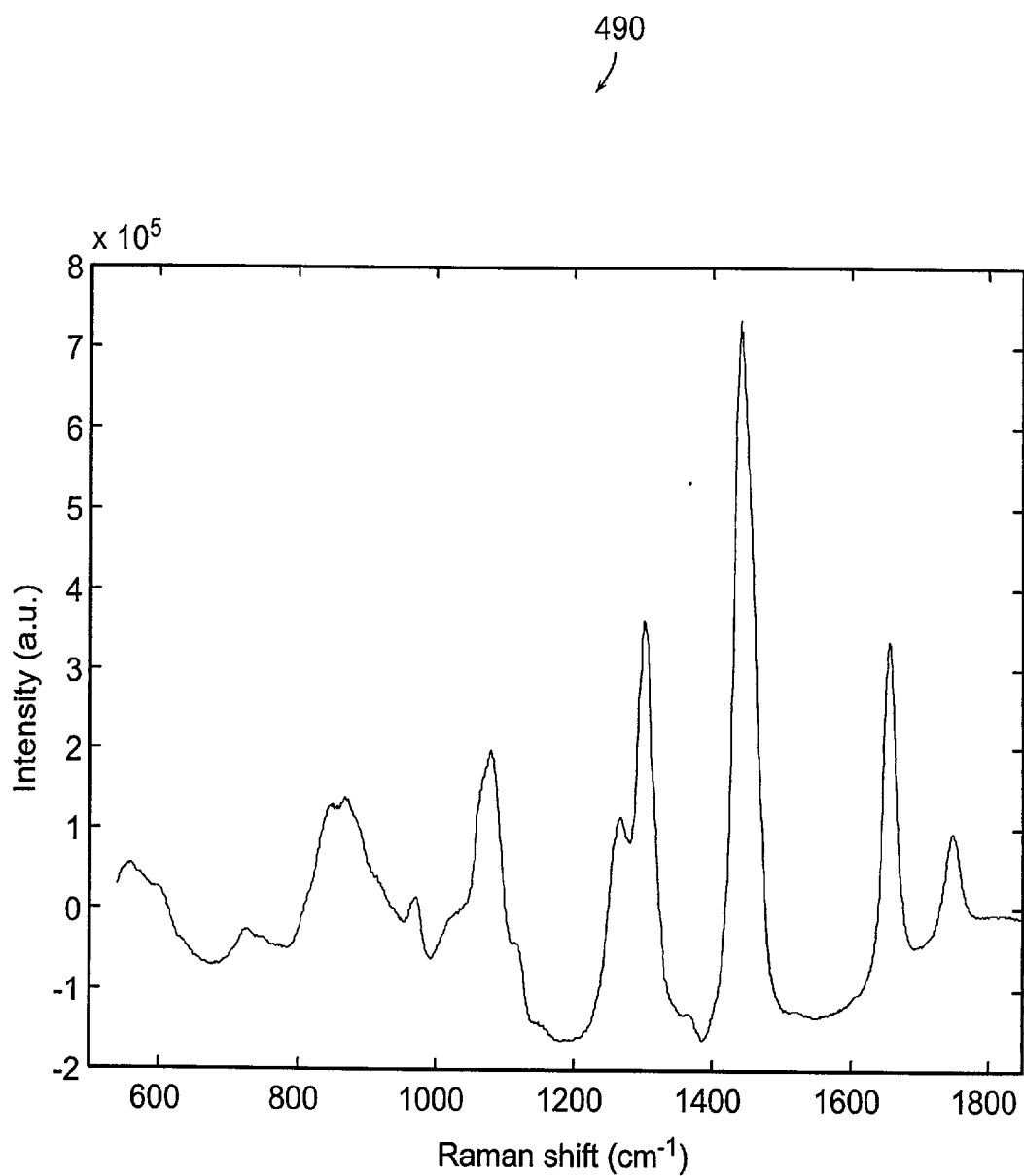

Figure 18

500 ↘

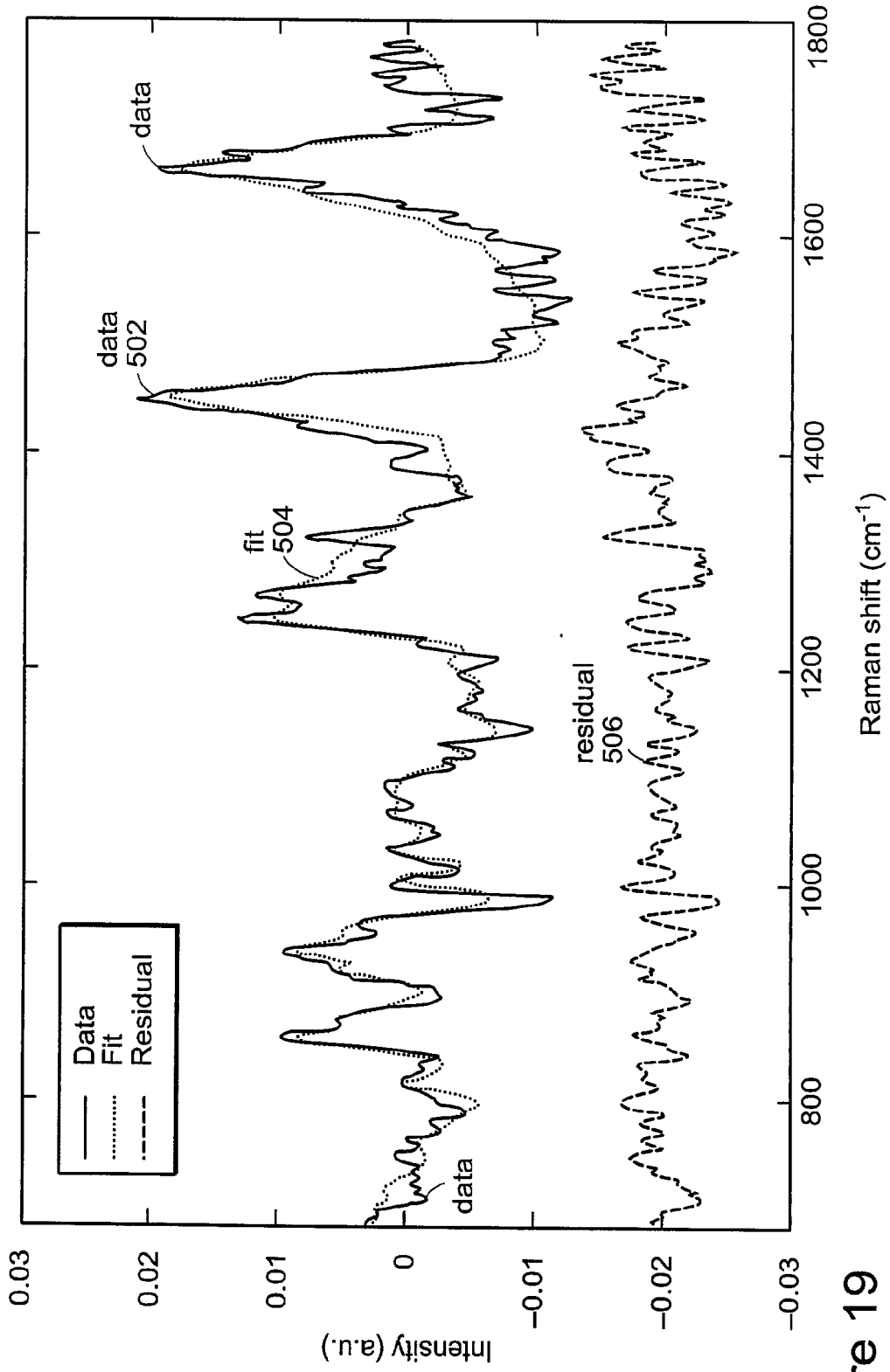

Figure 19

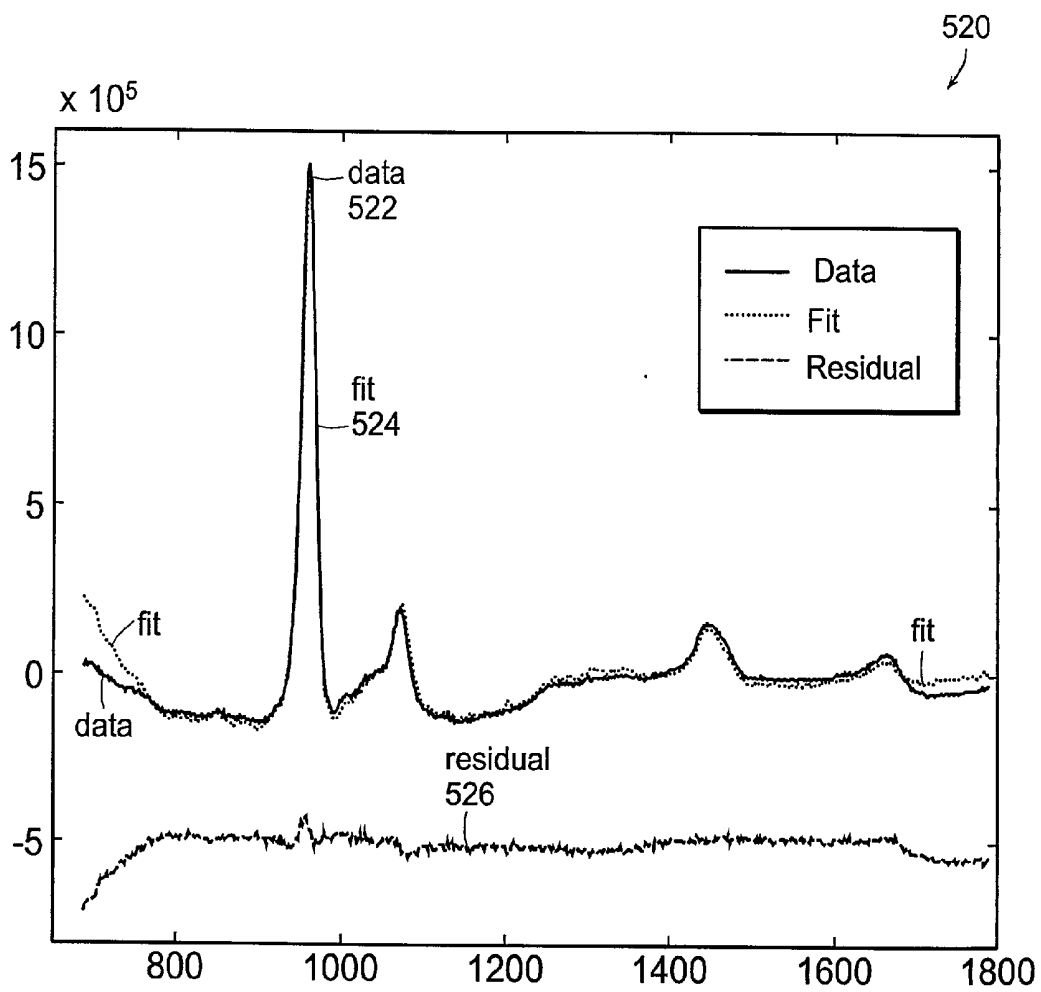

Figure 20

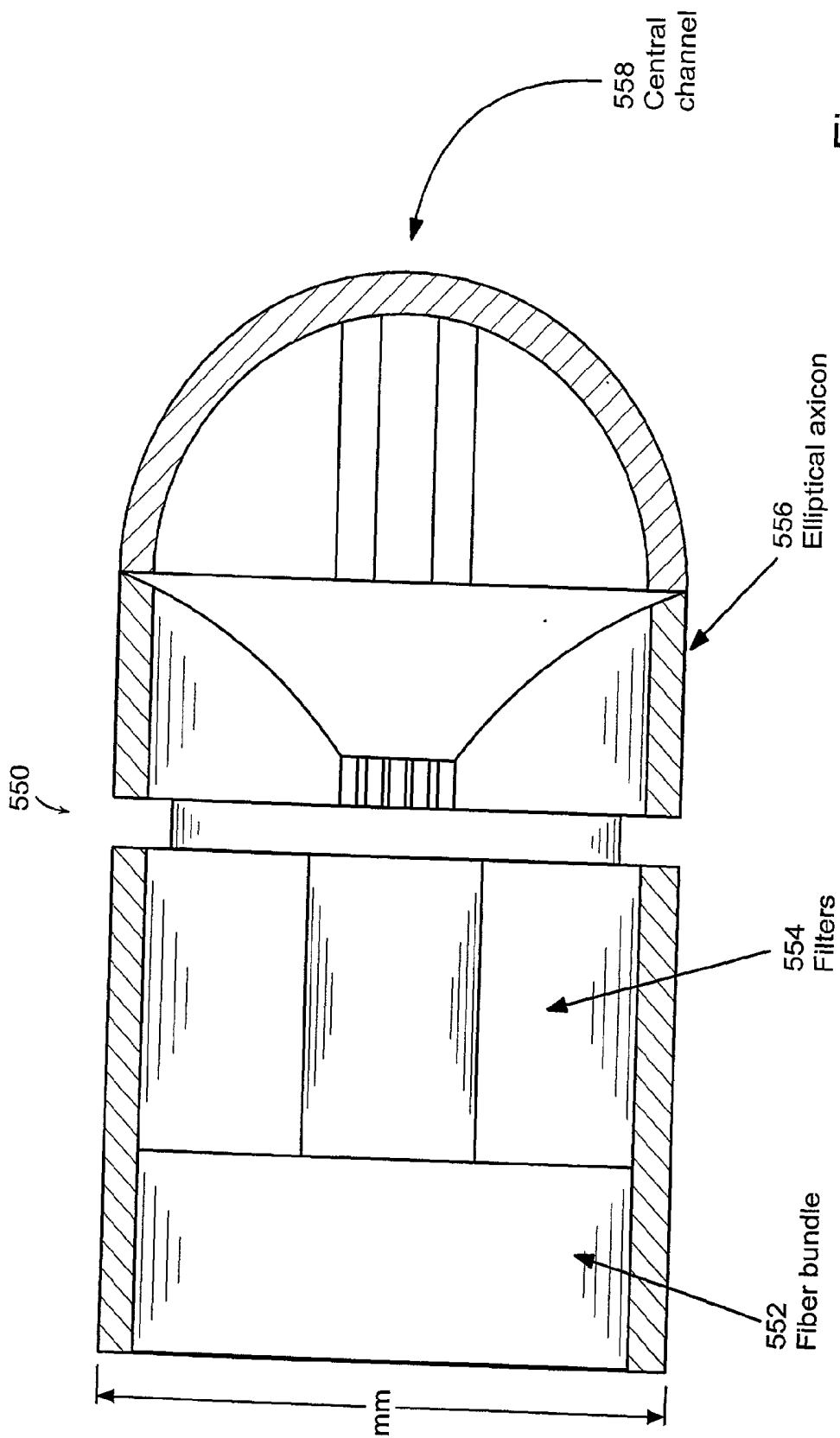

Figure 21A

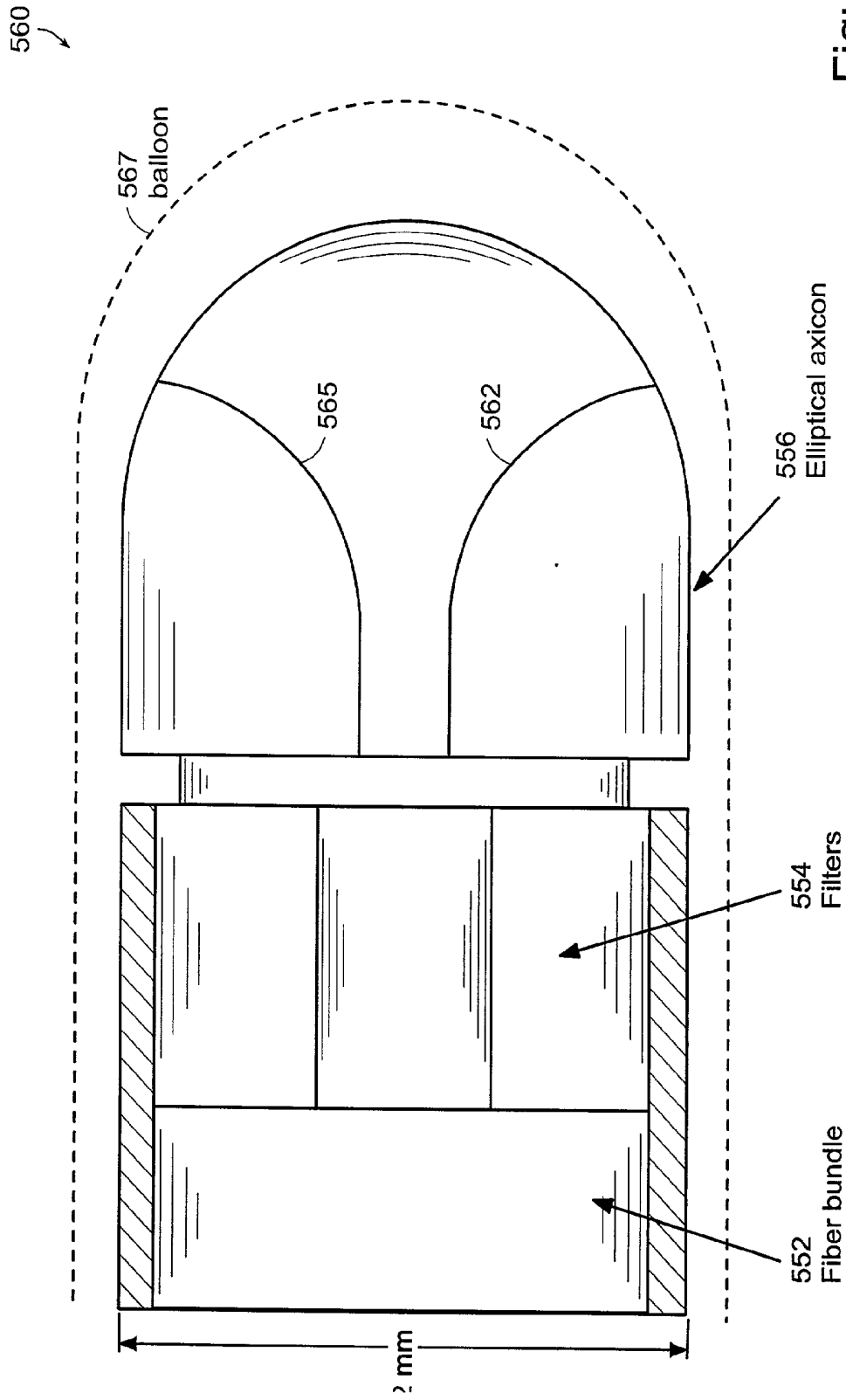

Figure 21B

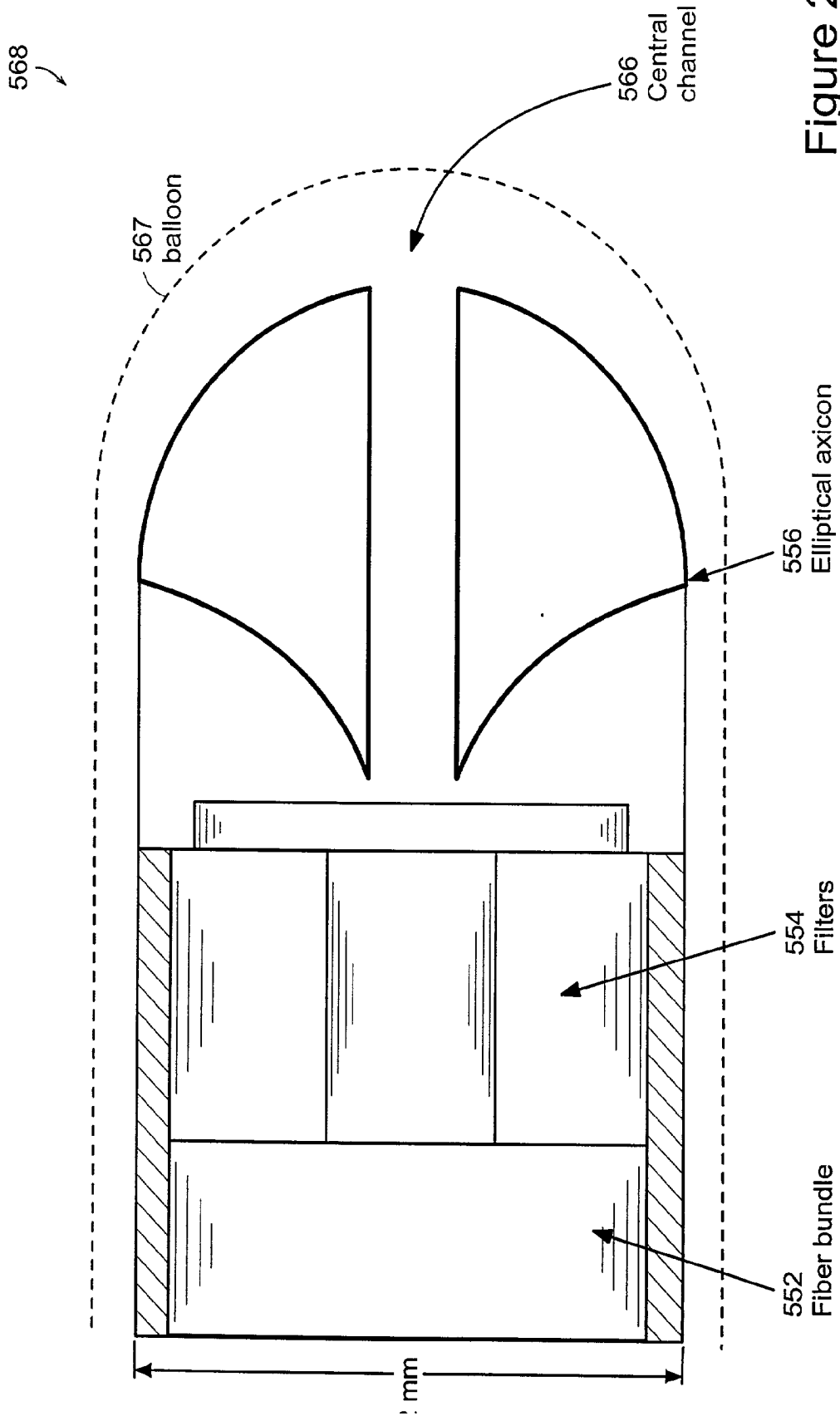

Figure 21C

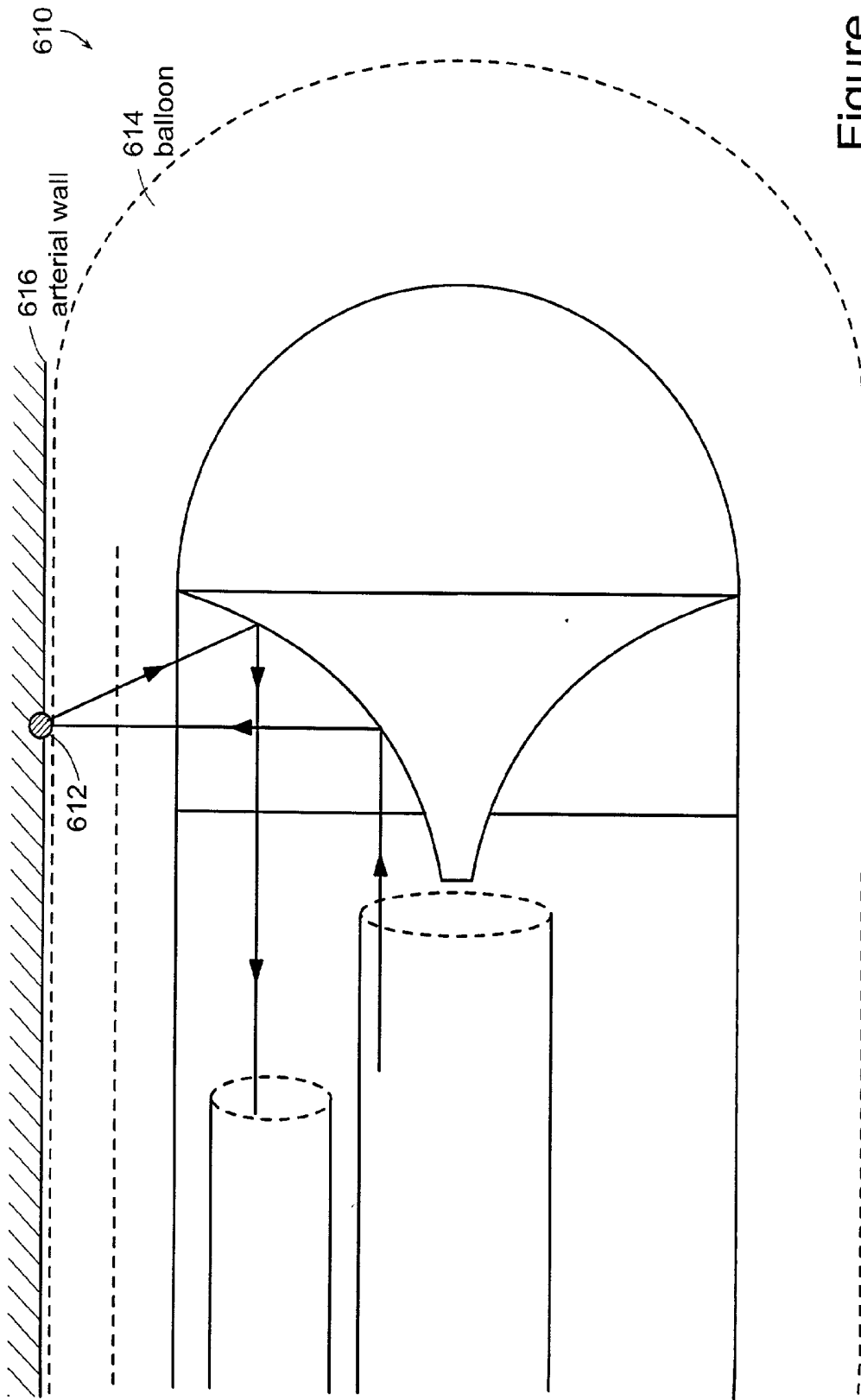

Figure 21D

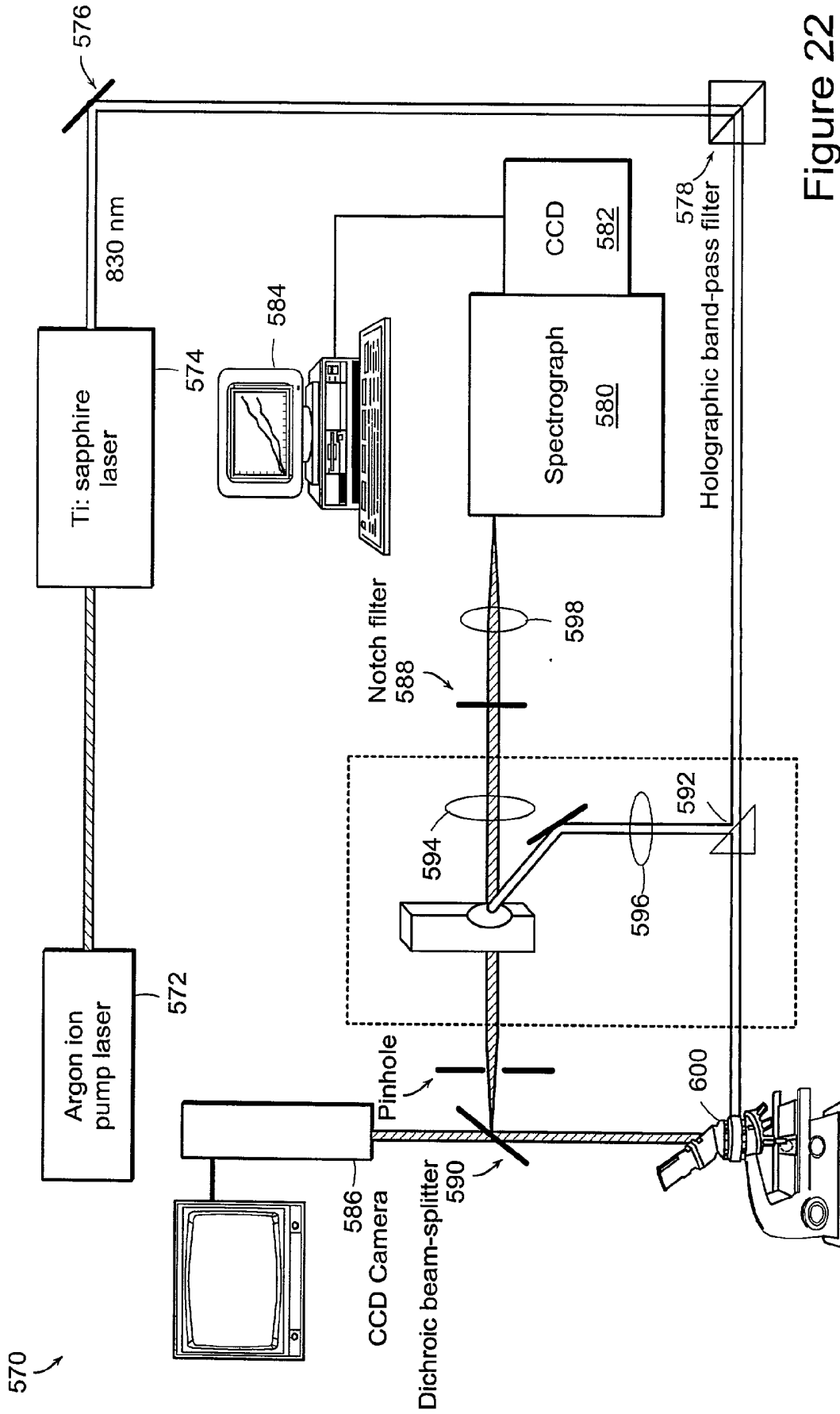

Figure 22

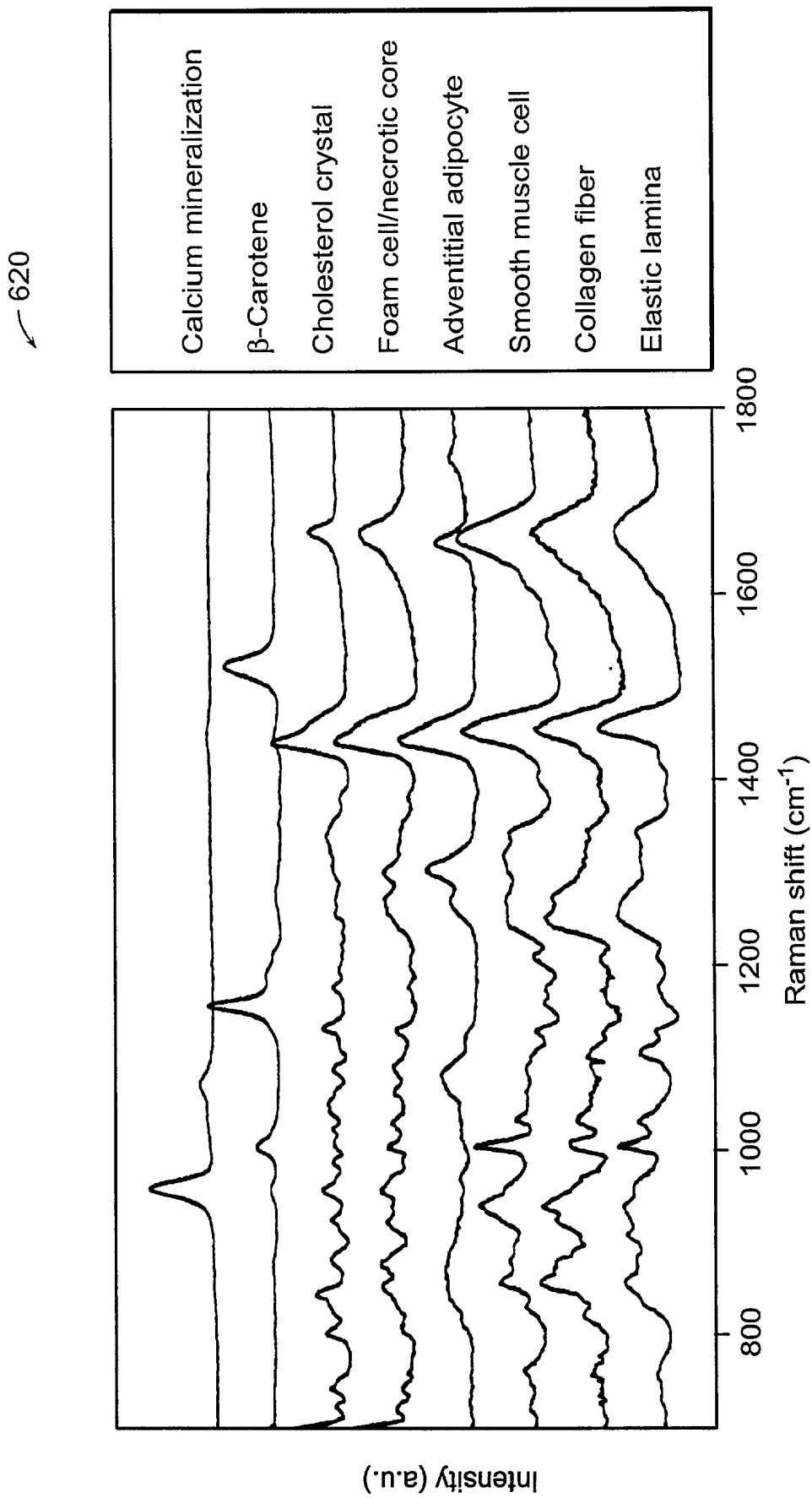

Figure 23

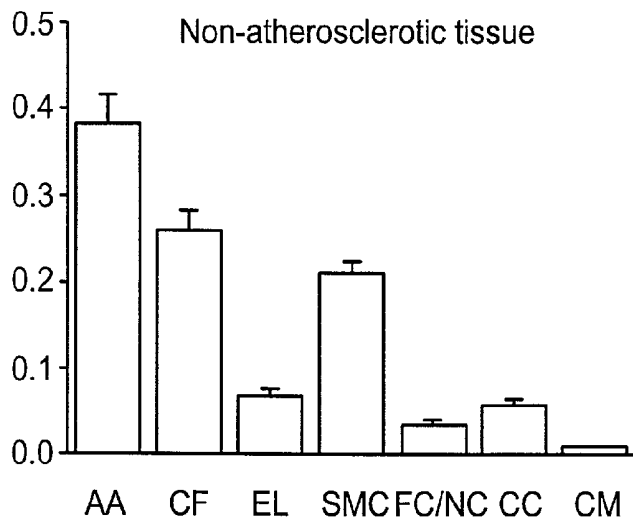

Figure 24A

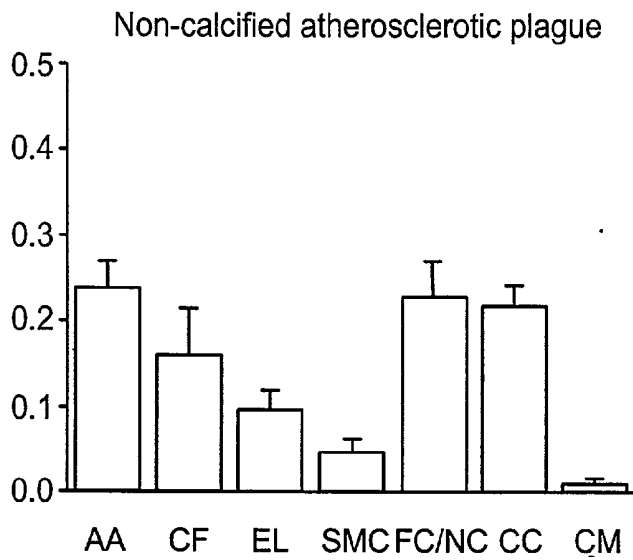

Figure 24B

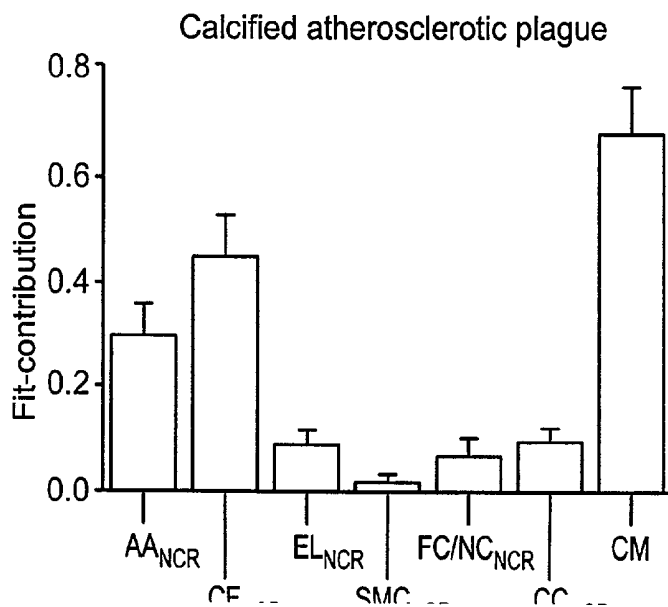

Figure 24C

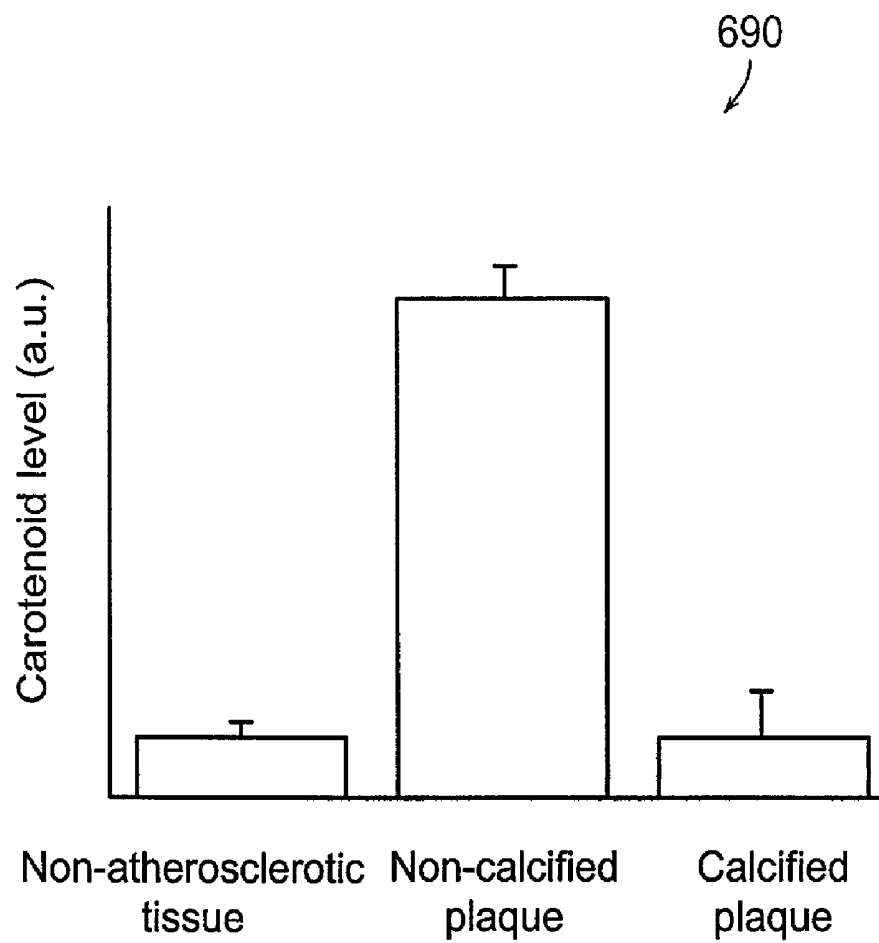

Figure 25

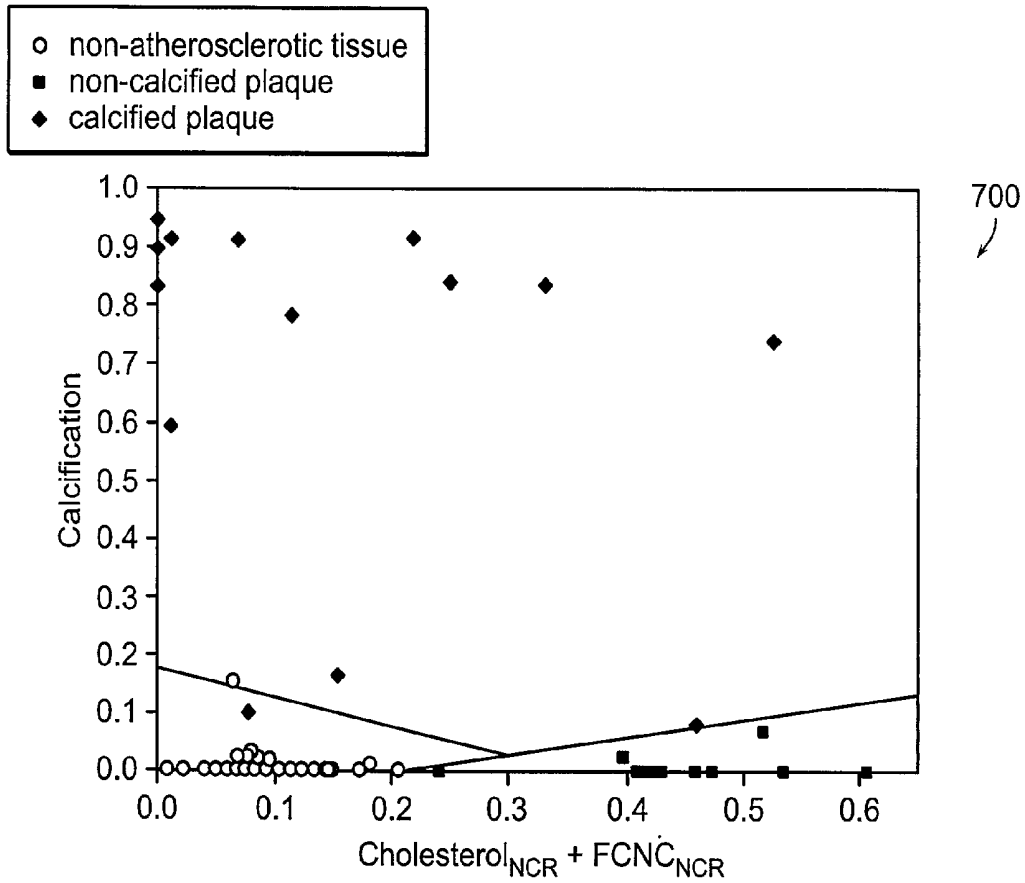
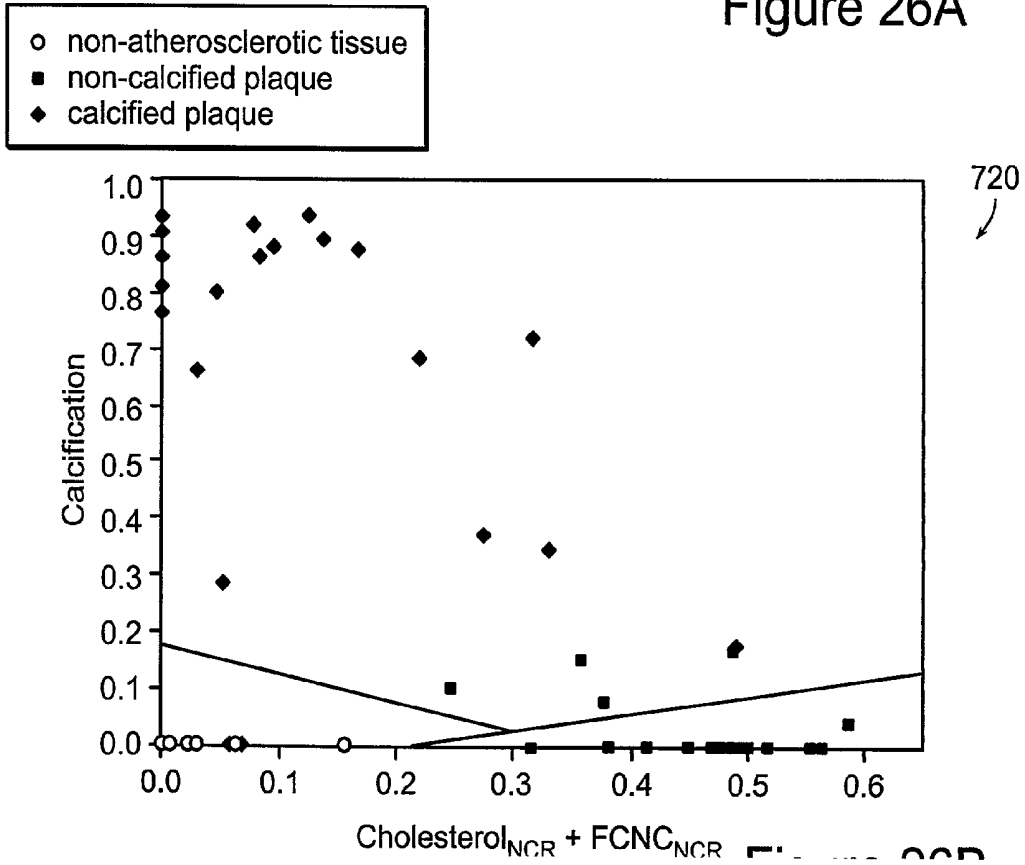

Figure 26A



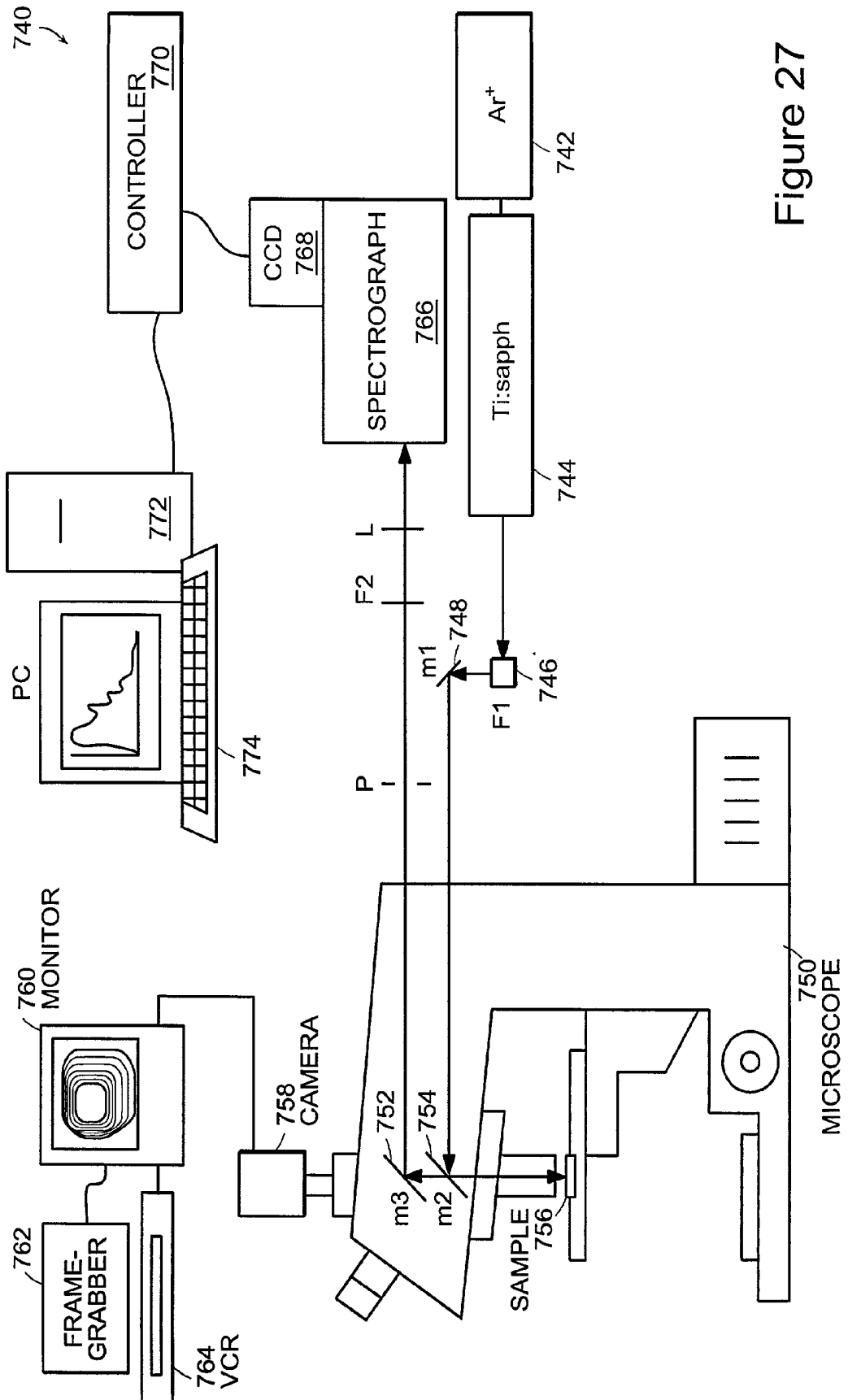

Figure 27

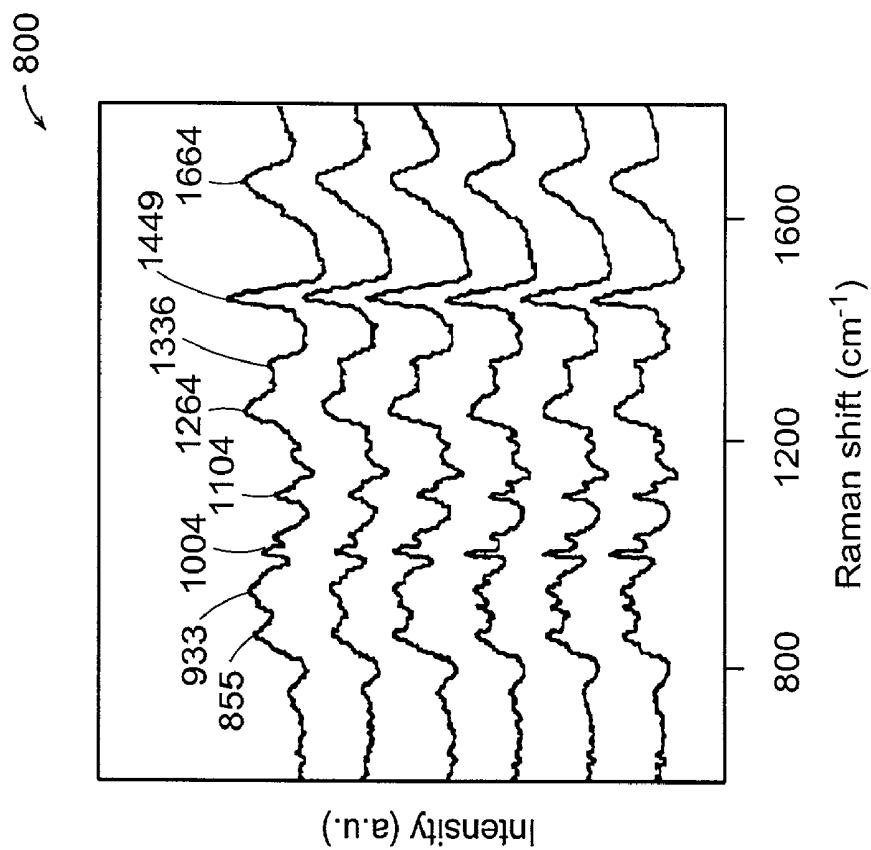

Figure 28B

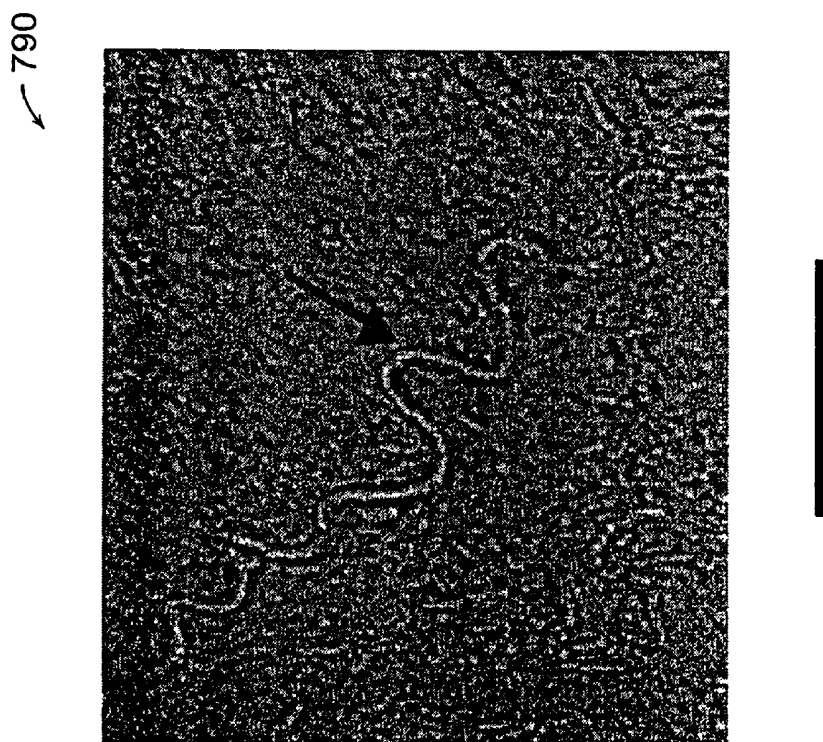

Figure 28A

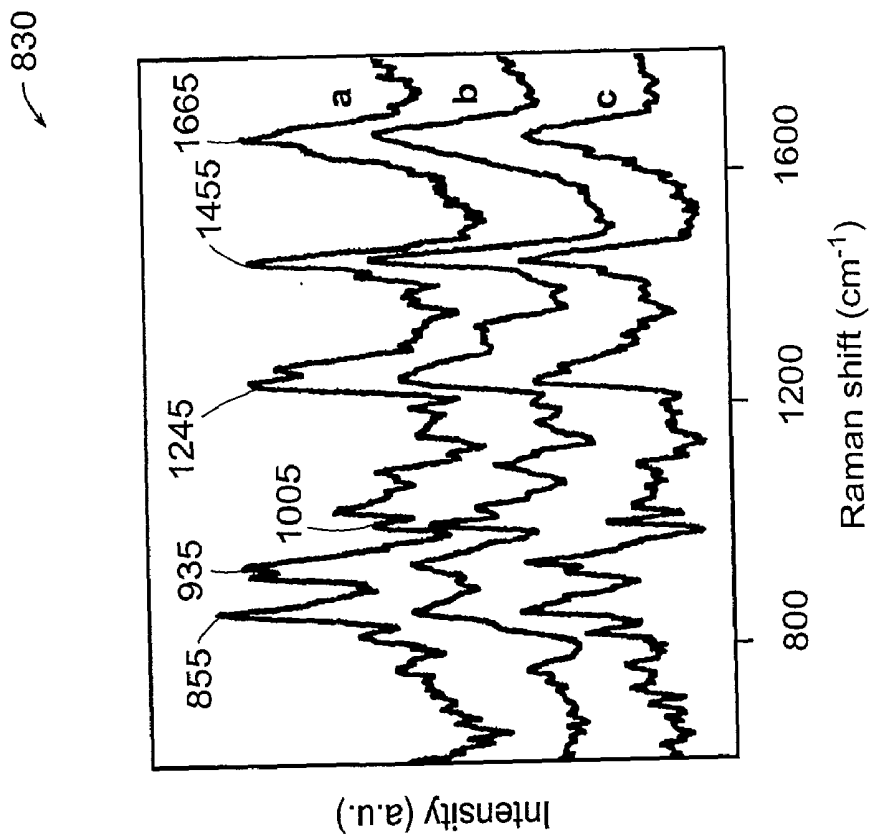

Figure 29B

820 ↙

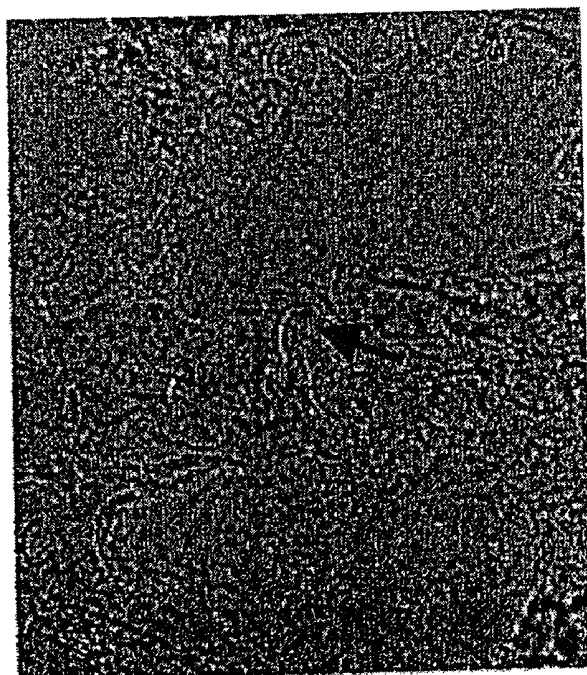

Figure 29A

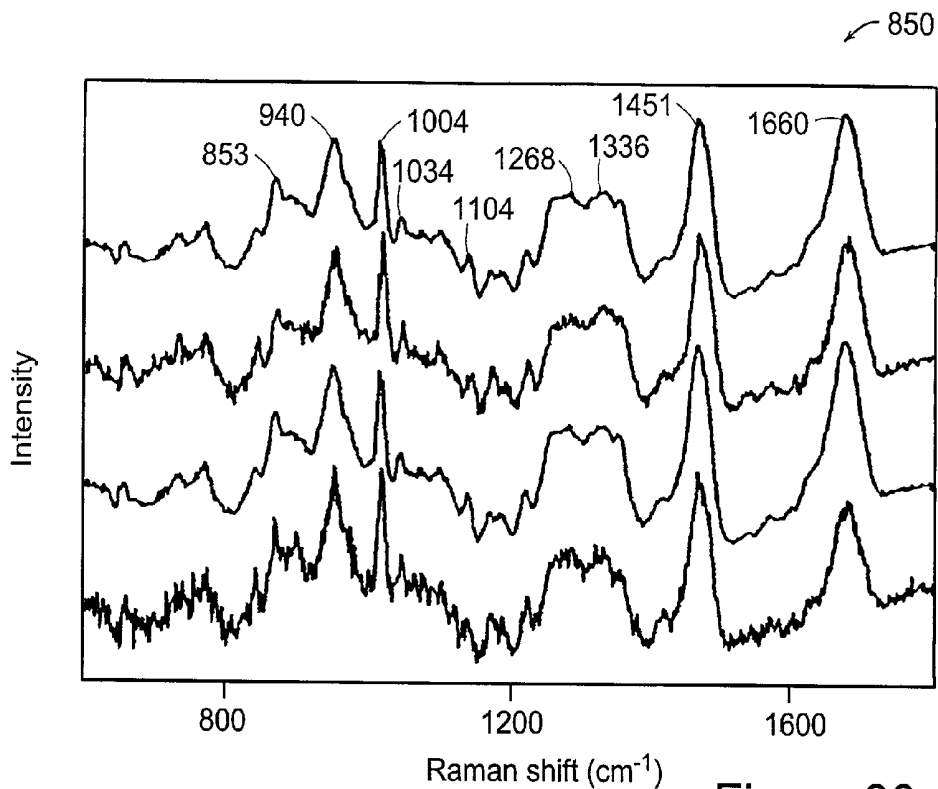

Figure 30

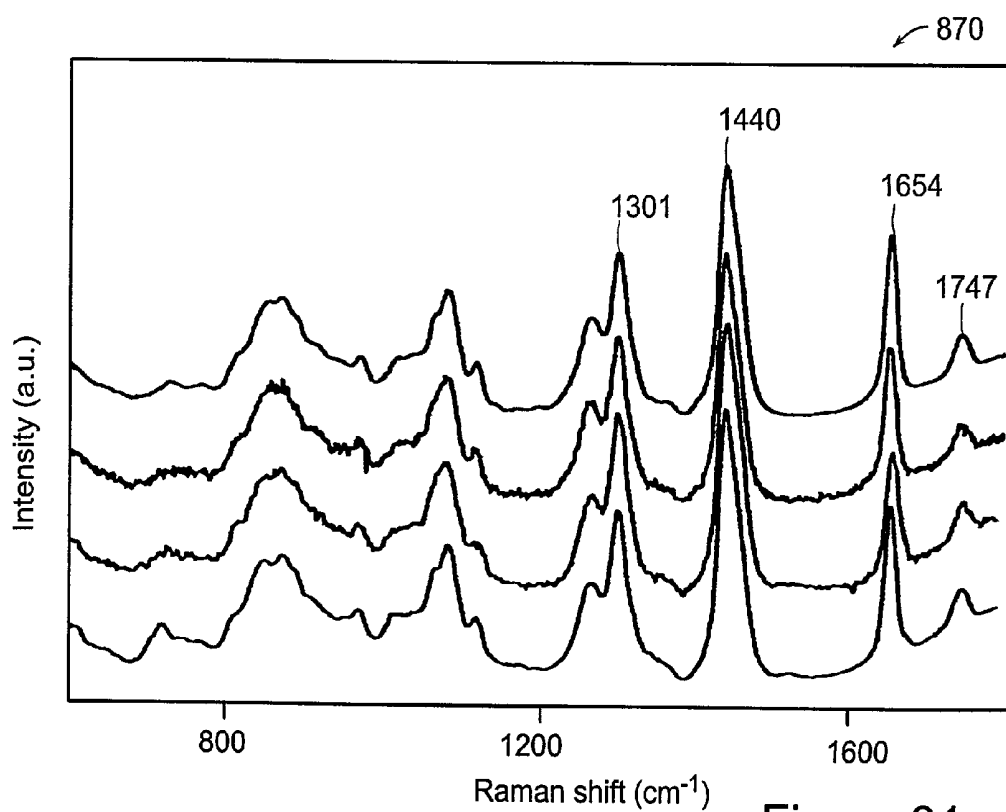

Figure 31

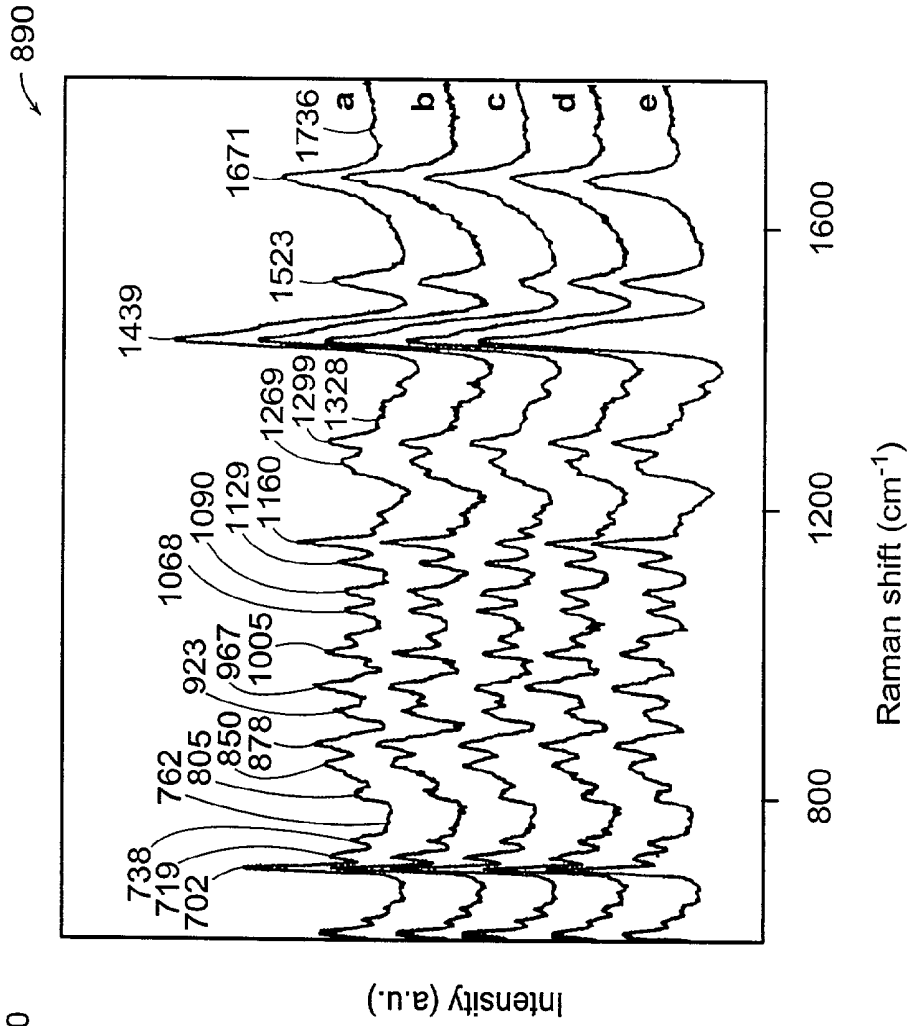
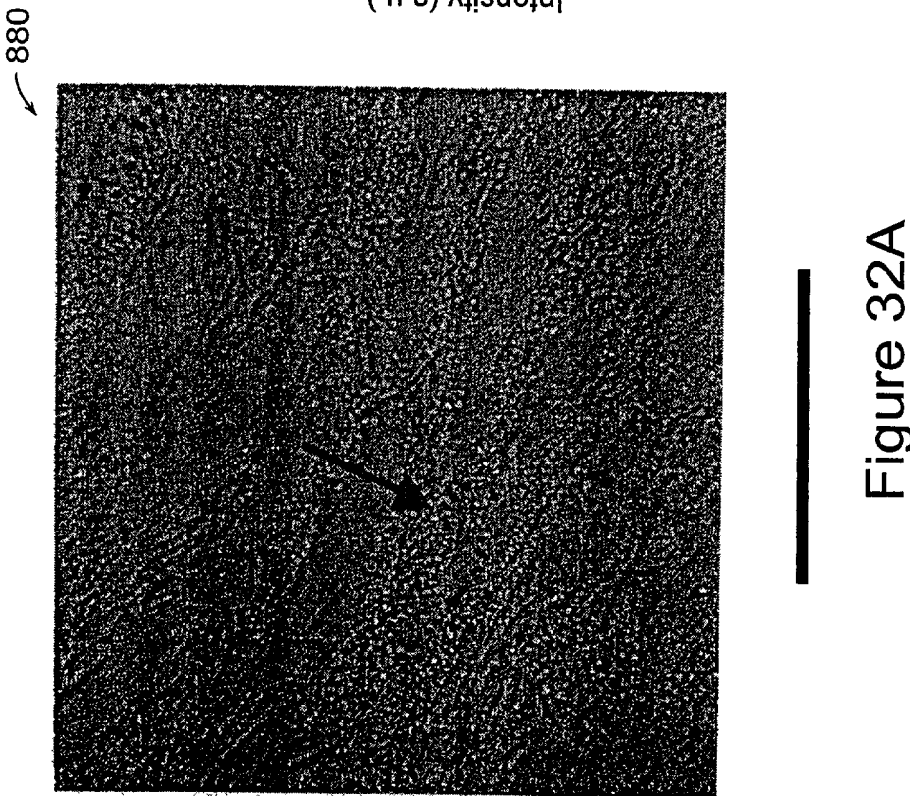

Figure 32B



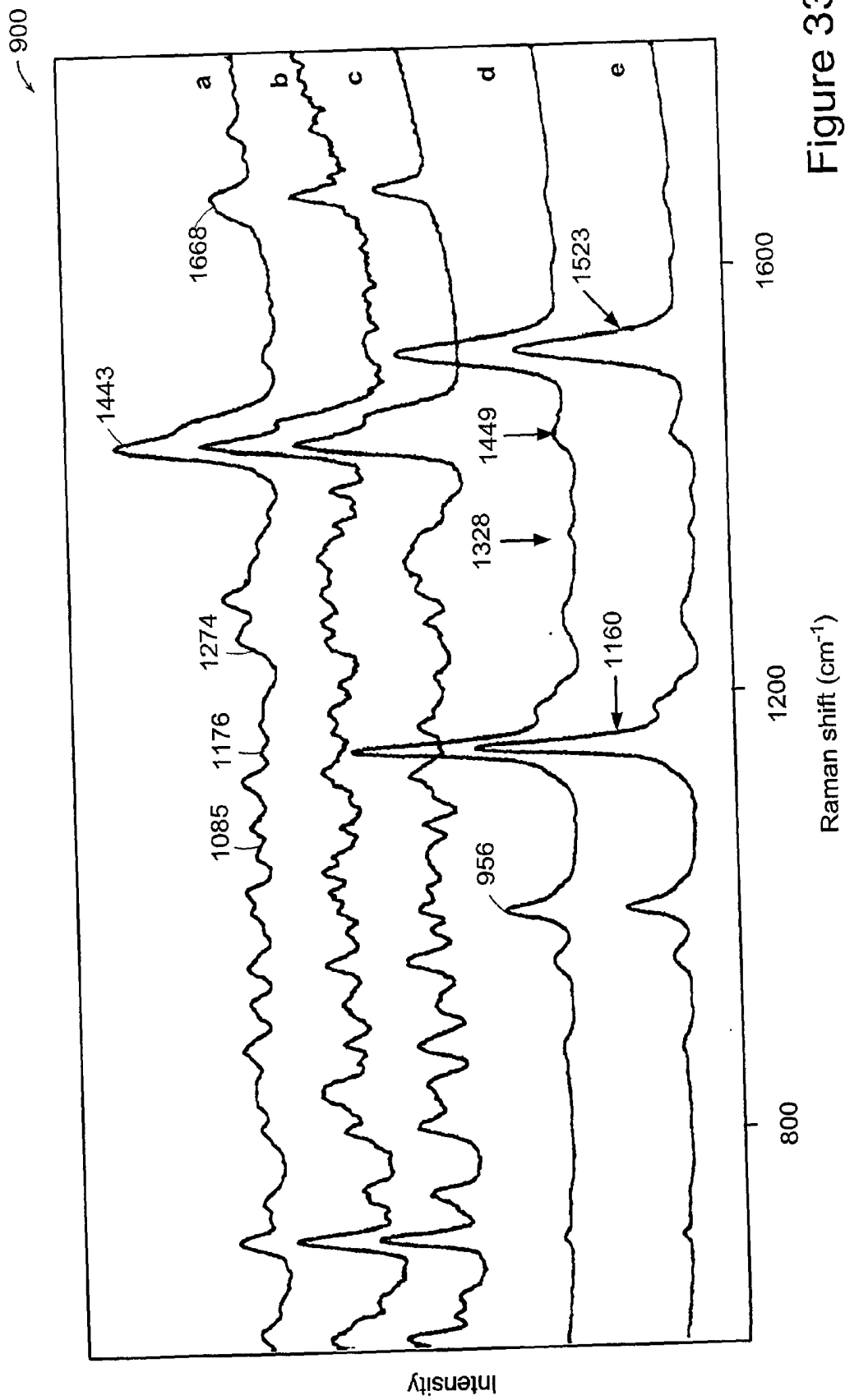

Figure 33

930 ↙

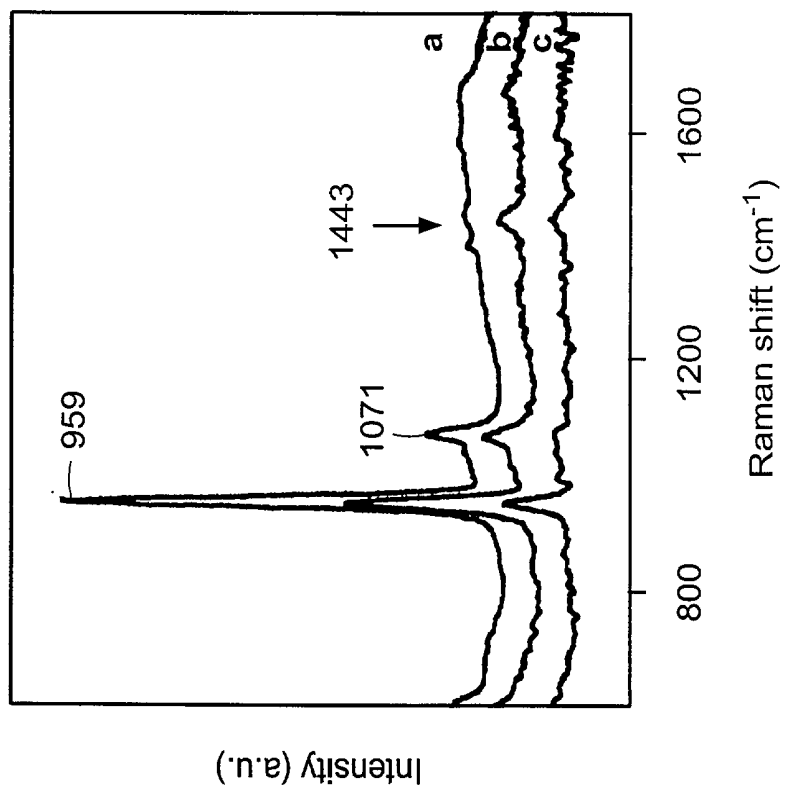

Figure 34B

920 ↙



Figure 34A

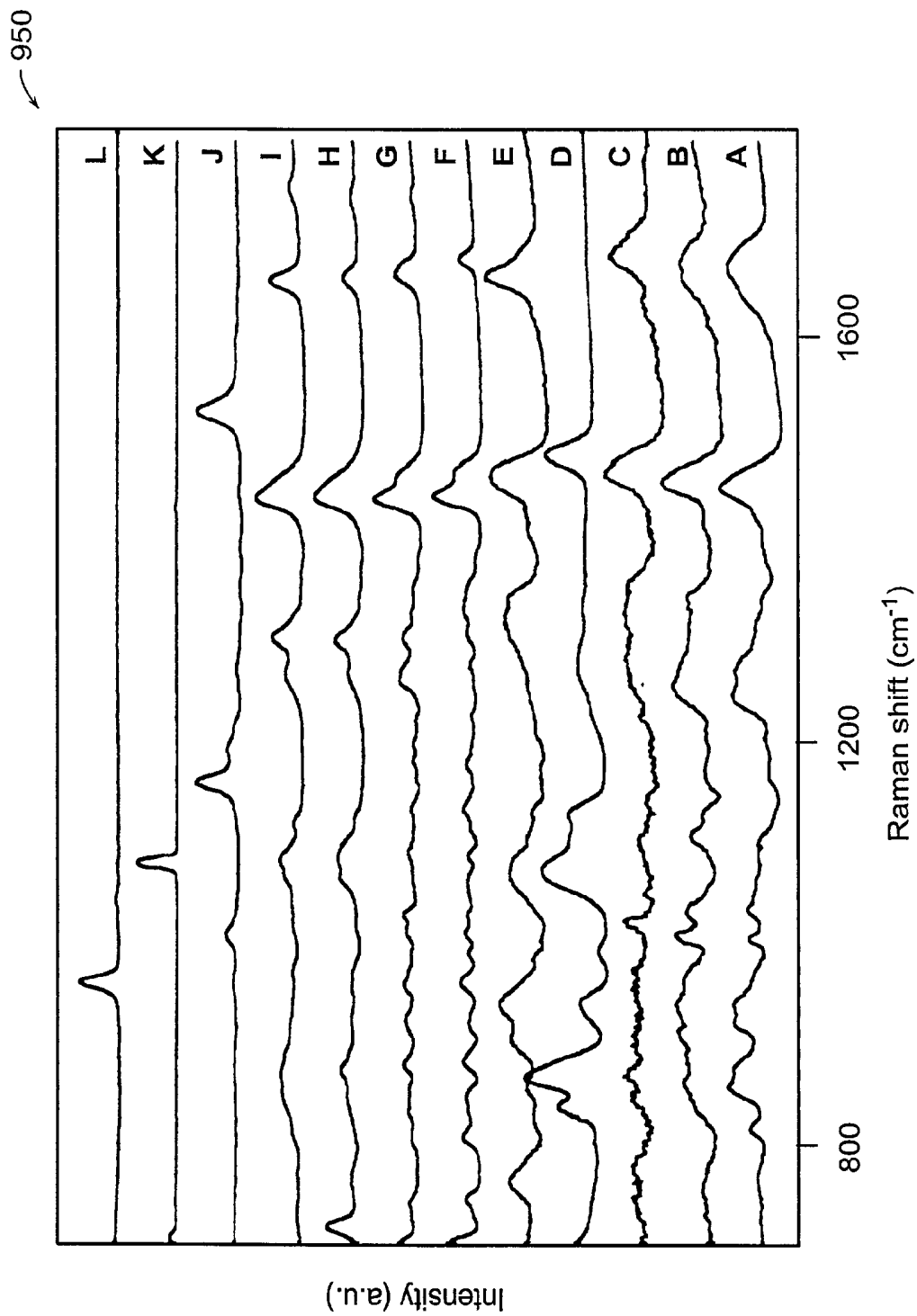

Figure 35

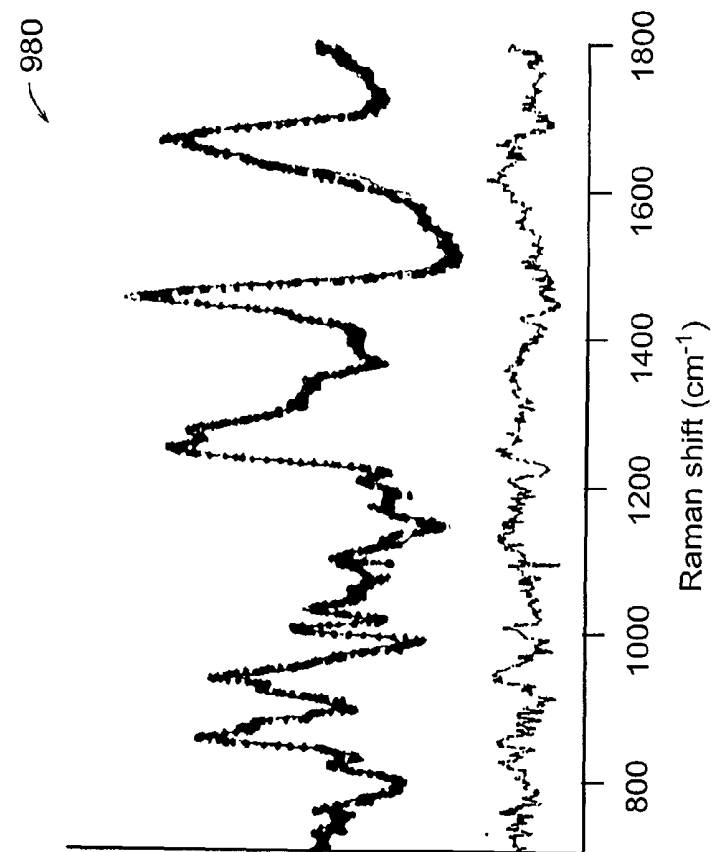

Figure 36B

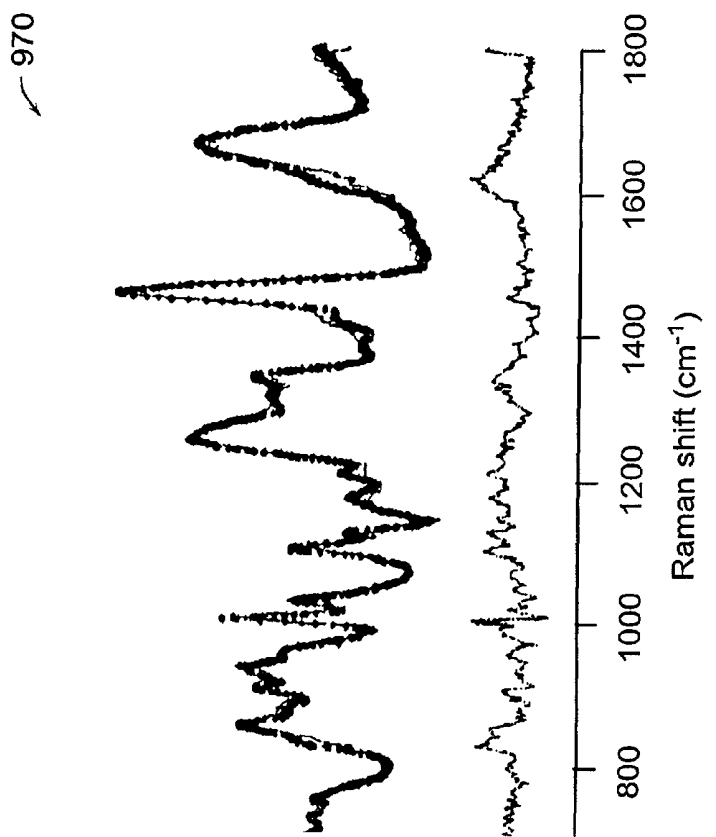

Figure 36A

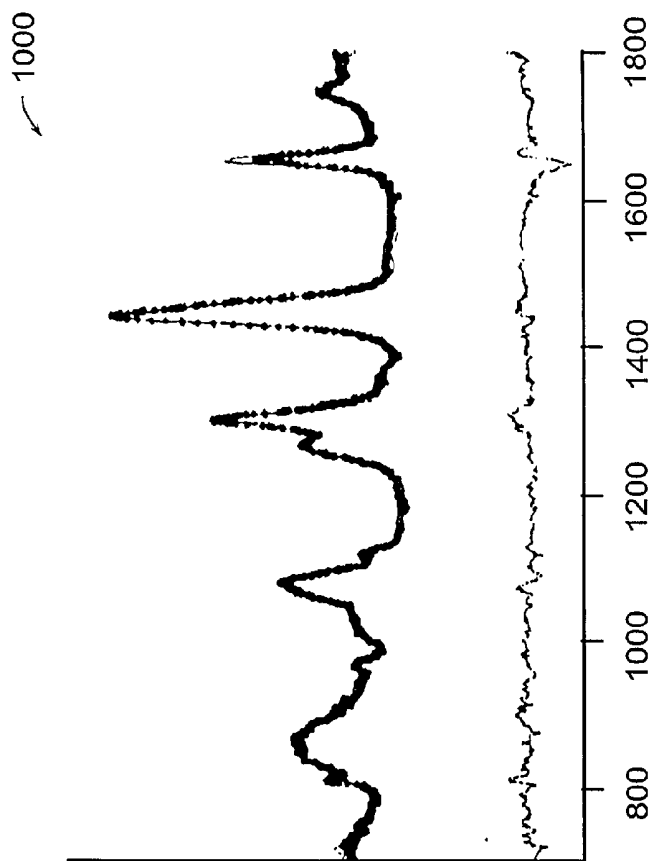

Figure 36D

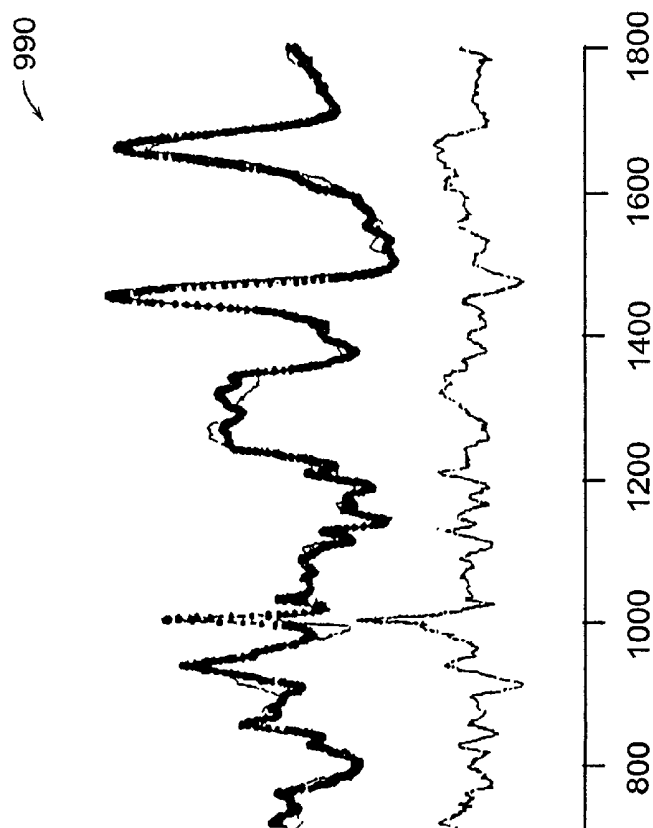

Figure 36C

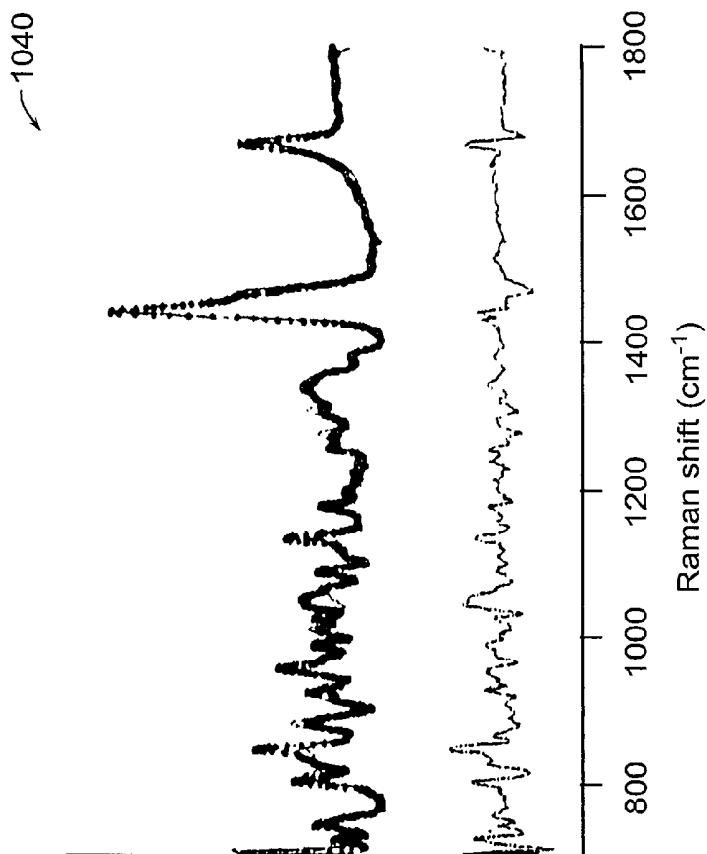

Figure 36F

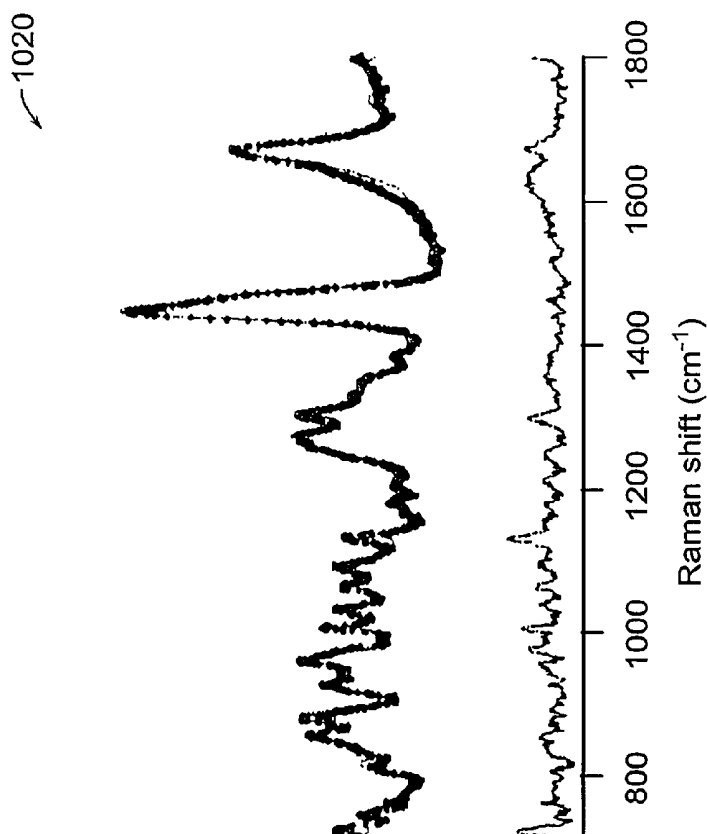

Figure 36E

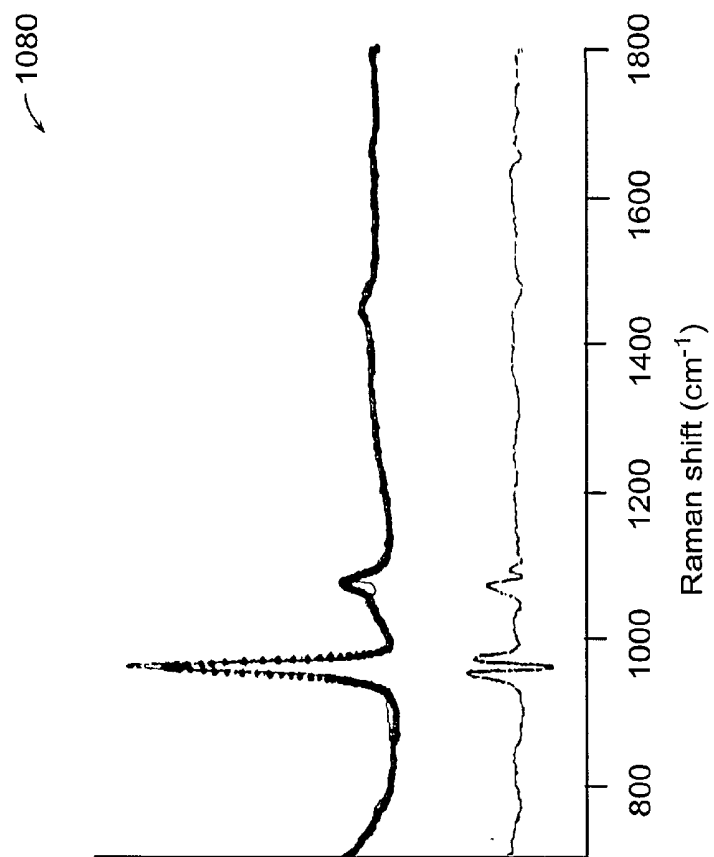

Figure 36H

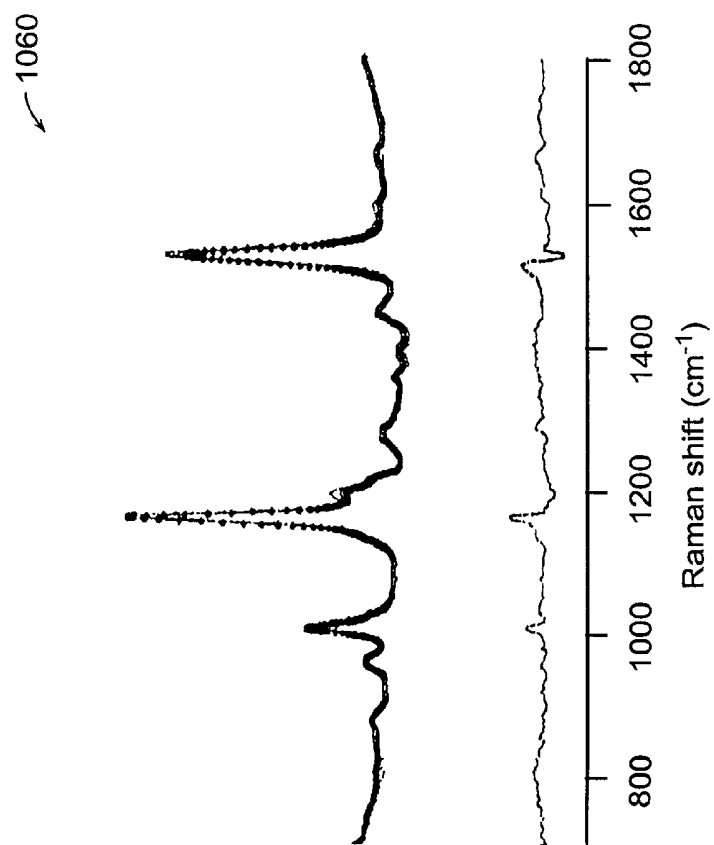

Figure 36G

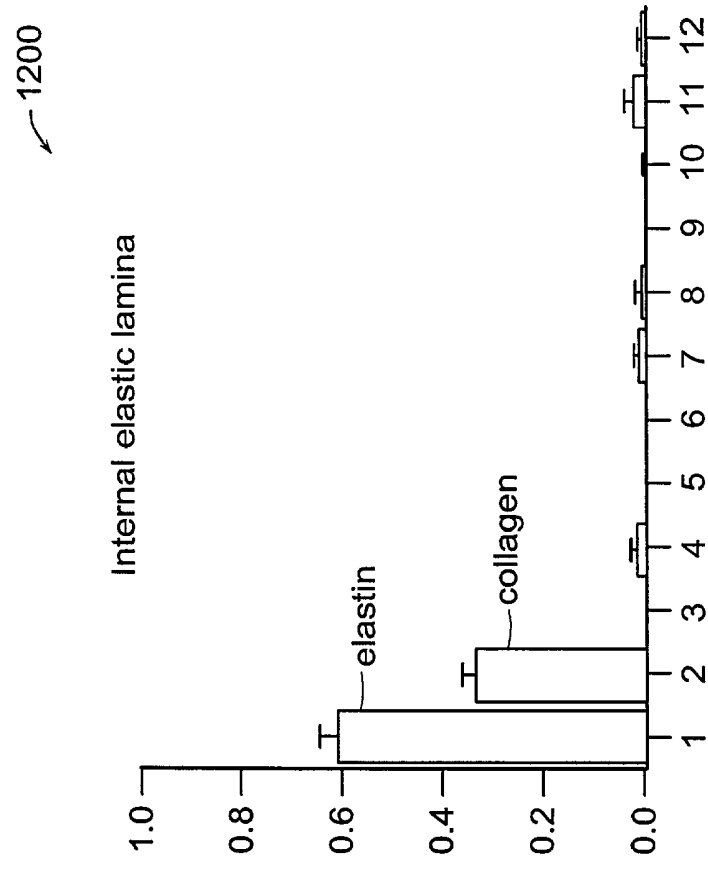
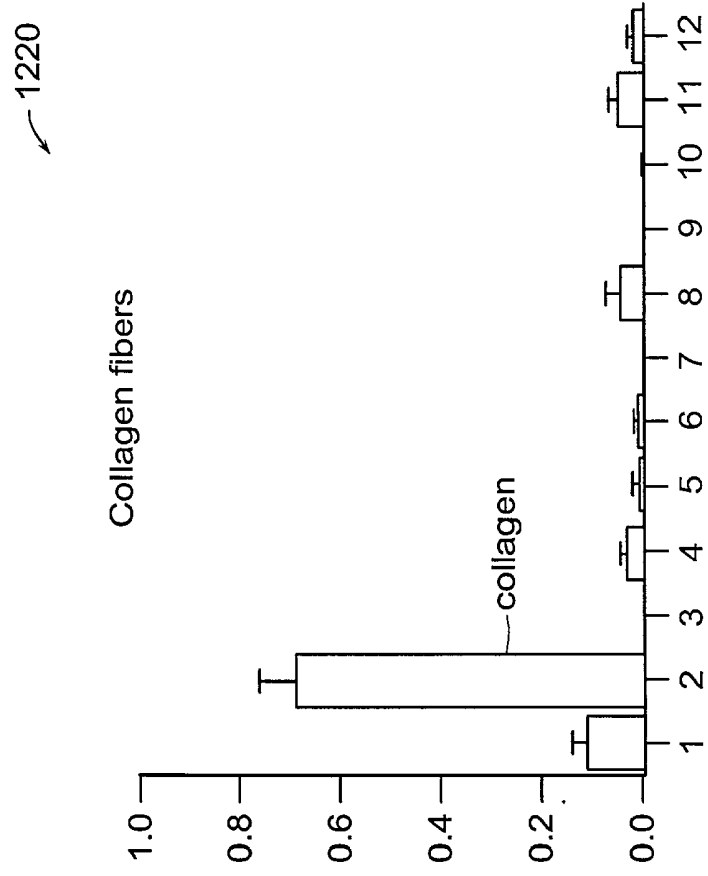

Figure 37B

Figure 37A

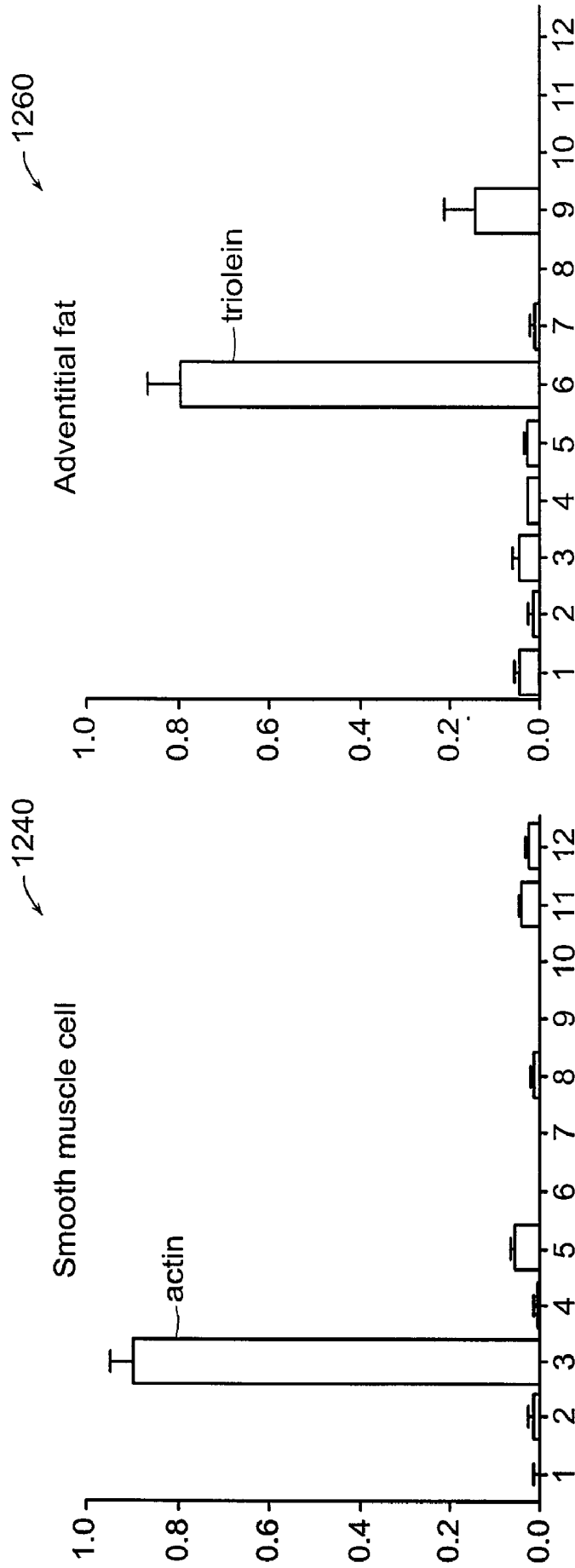

Figure 37D

Figure 37C

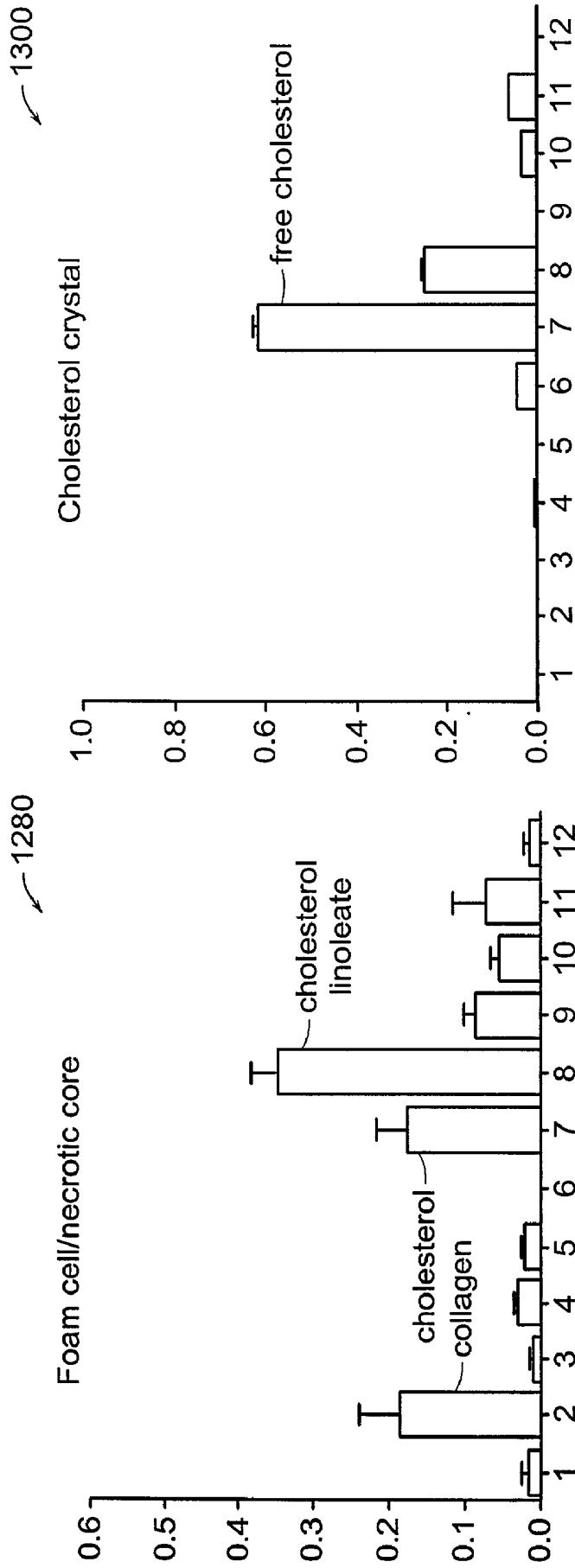

Figure 37F

Figure 37E

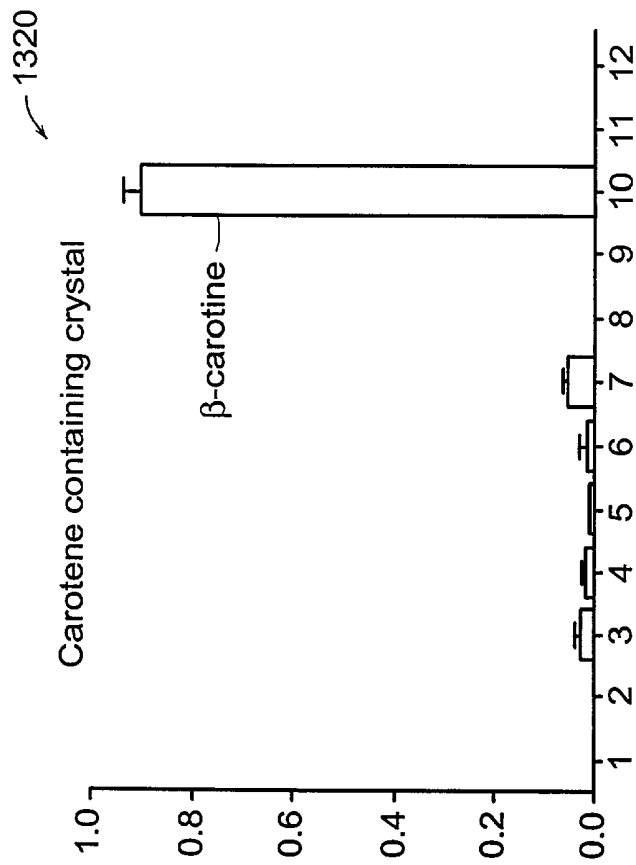
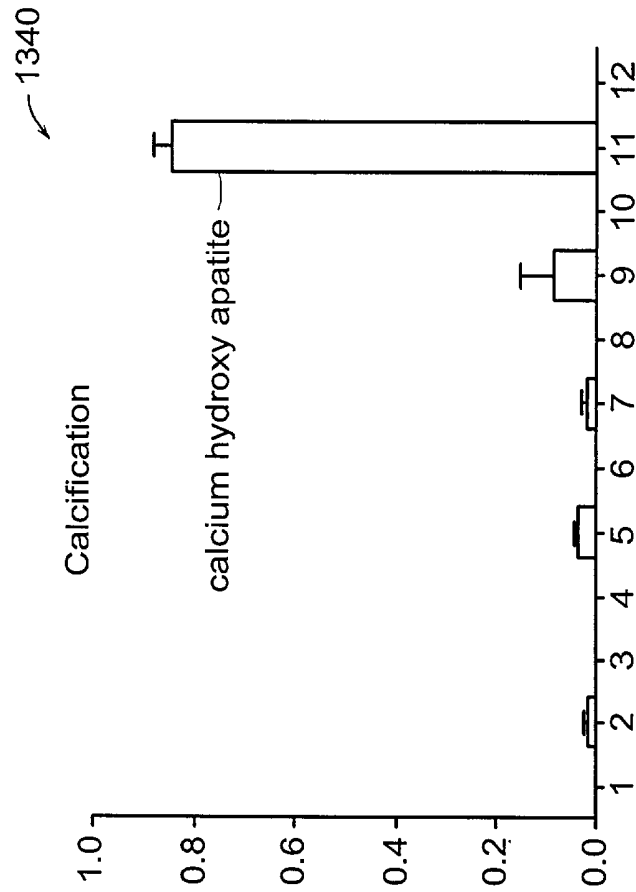

Figure 37H

Figure 37G

1360 ↘

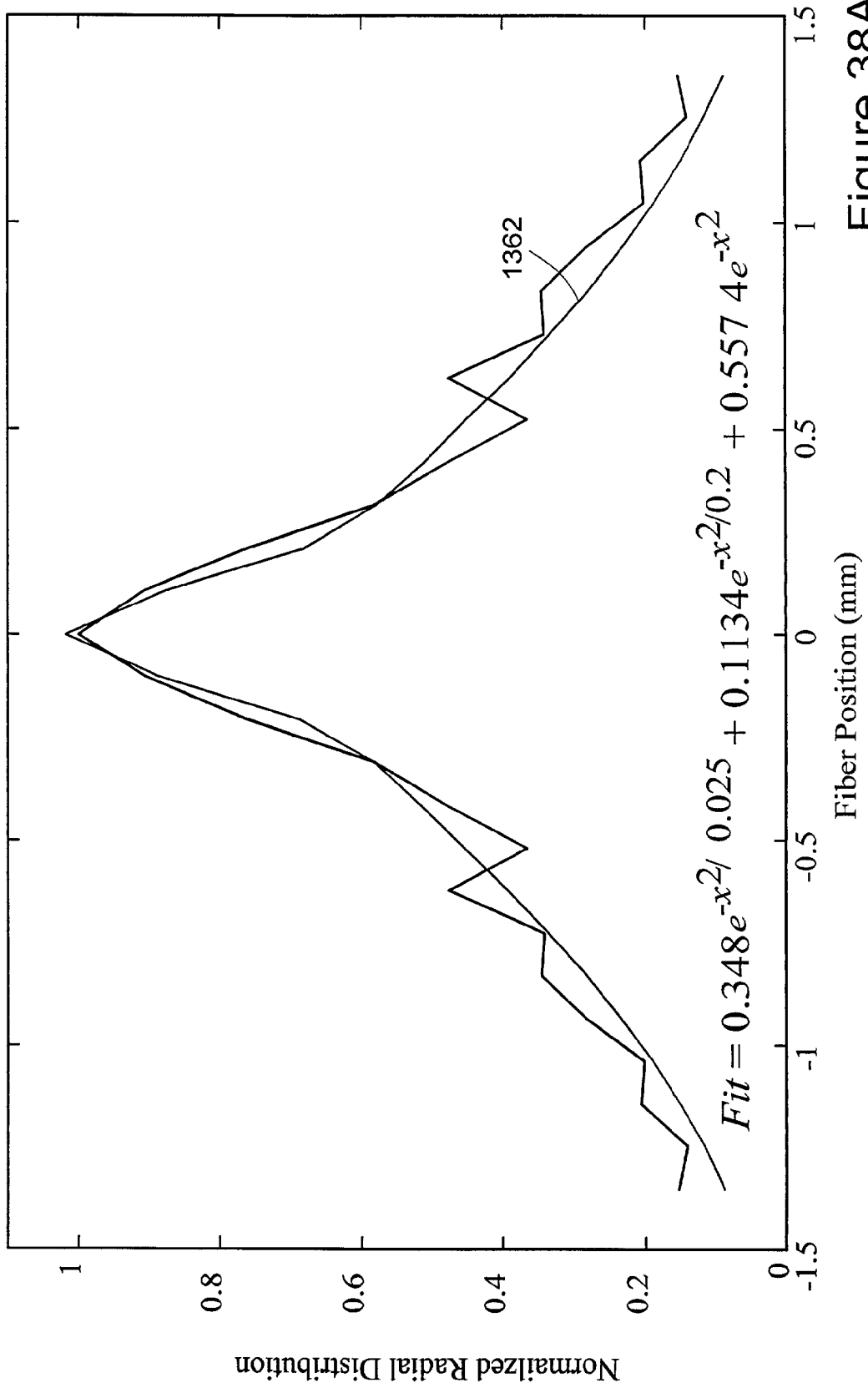

Figure 38A

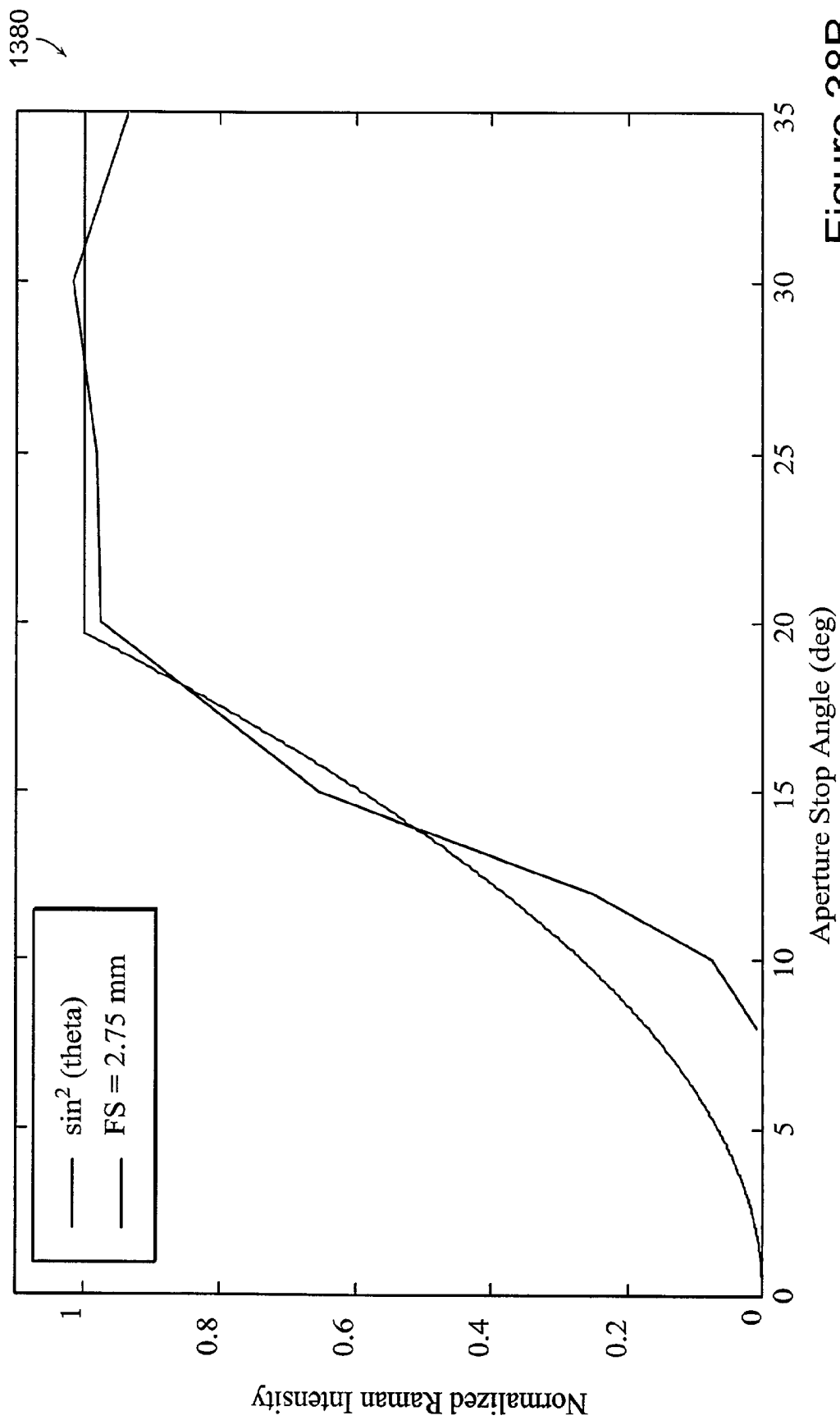

Figure 38B

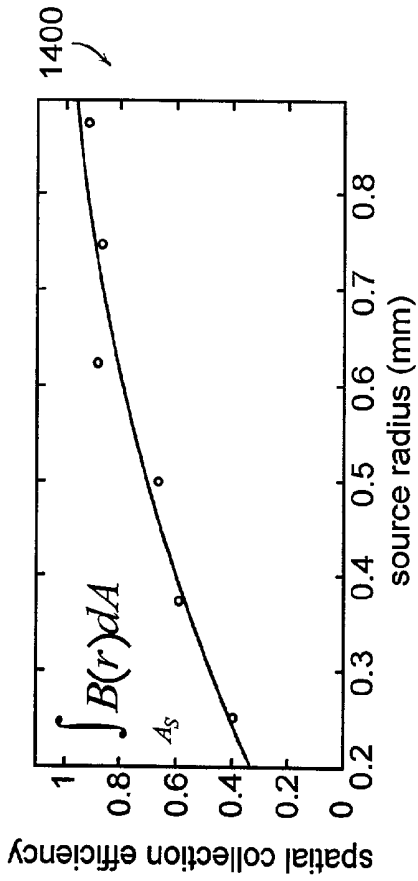

Figure 38C

⇒

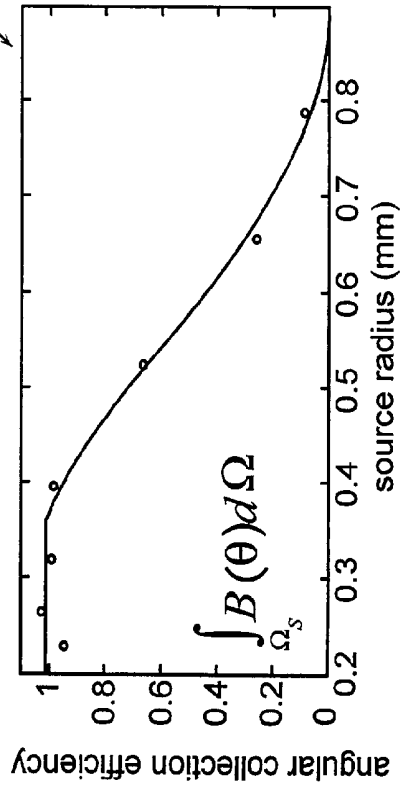

Figure 38D

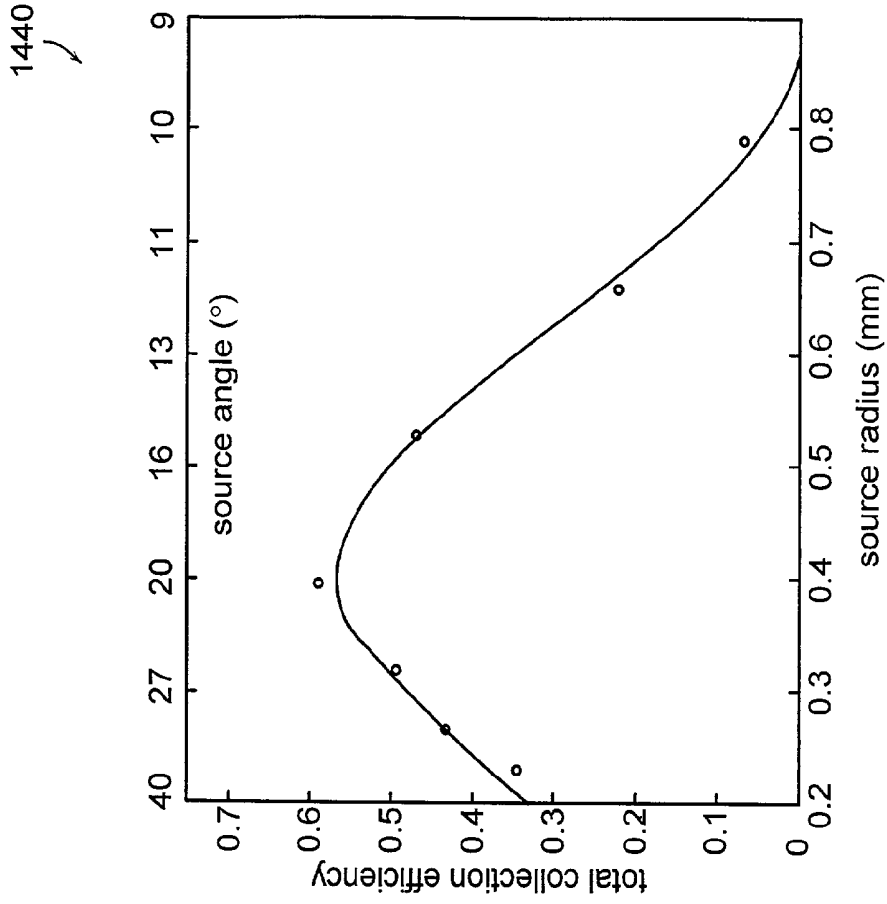

Figure 38E

## SYSTEMS AND METHODS FOR SPECTROSCOPY OF BIOLOGICAL TISSUE

### CROSS REFERENCES TO RELATED APPLICATIONS

[0001] The present application claims the benefit of the U.S. Provisional Patent Application No. 60/370,197, filed Apr. 5, 2002. The entire contents of the above application is incorporated herein by reference in its entirety.

### GOVERNMENT SUPPORT

[0002] This invention was supported, in whole or in part, by grants P41-RR-02594 and NIH-HL-64675 from the National Institute of Health. The Government has certain rights in the invention.

### BACKGROUND OF THE INVENTION

[0003] Optical methods are increasingly being used for the detection of disease. Near-infrared Raman spectroscopy in particular, because of its chemical specificity, is proving to be a useful tool for both disease diagnosis and the study of disease progression. Over the past decade Raman spectroscopy has been applied to many diseases and biological problems and there have been many advances in-vitro. More recently there have been reports of in-vivo work that however have either been confined to studies of skin or other easily accessible organs, or have used optical fiber configurations that require collection times that are unreasonably long for practical clinical use. The majority of applications require remote sampling via optical fibers, and the size of the probe and fiber bundle is strictly limited by the application. A particular example that current commercial systems cannot provide is the ability to evaluate atherosclerotic lesions in-vivo in real-time, through an angiographic catheter, thus aiding cardiologists in directing the most appropriate treatment in each individual case. These objectives have not been fulfilled by current systems.

[0004] In addition, prior art probes for remote Raman sensing, using several different methods for filtering out the fiber spectral background, either exhibit extremely low optical throughput or are too bulky to be used intravascularly. A problem with the prior art designs includes having a 4 cm long stiff tip that prohibits their incorporation into transcatheter catheters for accessing the coronary arteries. Secondly, in data collected with these probes, a considerable component of the fiber Raman spectrum still remains. Further, data collection times on the order of 30 seconds or longer are typically required for collection of signals with an acceptable signal to noise ratio (SNR).

[0005] A need still exists for improved systems and methods which include probes for, for example, Raman spectroscopy that are sized for applications in medicine and provide an improved spectral signature from tissue.

### SUMMARY OF THE INVENTION

[0006] The system and method of the present invention relates to using spectroscopy, for example, Raman spectroscopic methods for diagnosis of tissue conditions such as vascular disease or cancer. The system and methods of the present invention have several applications: optical breast biopsies and breast analysis through ductoscopy, percutaneous blood analysis and monitoring, vascular stenosis, gas-

trointestinal cancer evaluation, scanning for dysplasia in the pancreatic duct and skin analyses.

[0007] In accordance with a preferred embodiment of the present invention, a system for measuring tissue includes a fiber optic probe having a proximal end, a distal end, and a diameter of 2 mm or less. This small diameter allows the system to be used for the diagnosis of coronary artery disease or other small lumens or soft tissue with minimal trauma. A delivery optical fiber (or fibers) is included in the probe coupled at the proximal end to a light source. A filter for the delivery fibers is included at the distal end. The system includes a collection optical fiber (or fibers) in the probe that collects Raman scattered radiation from tissue, the collection optical fiber is coupled at the proximal end to a detector. A second filter is disposed at the distal end of the collection fibers. An optical lens system is disposed at the distal end of the probe including a delivery waveguide coupled to the delivery fiber, a collection waveguide coupled to the collection fiber and a lens.

[0008] The delivery waveguide comprises a rod and the collection waveguide comprises a cylindrical tube, the tube being concentric about the rod. In an alternate preferred embodiment, the delivery waveguide comprises a first tube and the collection waveguide comprises a second cylindrical tube, the second tube being concentric about the first tube. Further the lens includes a ball lens optically coupled to the delivery fiber and the collection fiber.

[0009] In a preferred embodiment, the probe further comprises a sleeve that optically isolates the delivery waveguide from the collection waveguide. The sleeve can be metallic, such as palladium, silver or gold. The glass rod tube and sleeve can be attached together with an adhesive. An outer retaining sleeve can attach the distal optics to the fiber optics.

[0010] The probe further comprises a first plurality of collection fibers arranged concentrically about the delivery fiber at a first radius, and a second plurality of collection fibers arranged concentrically about the delivery fiber at a second radius that is larger than the first radius.

[0011] In accordance with another aspect of the present invention, the probe includes a controller that gates a collection time, the collection time being less than 2 seconds. In one embodiment, the optical lens system has a length less than 10 mm. In a preferred embodiment, the optical lens system has a length of less than 4 mm. The diameter of the distal optical system is preferably in the range of 1-2 mm. The optical lens systems delivers and collects radiation in a radial direction, which can be defined as any off-axis direction. The light source has a wavelength longer than 750 nm with a preferred embodiment using an argon laser pumped Ti: sapphire laser emitting at 830 nm. In an alternate embodiment a diode laser such as a InGaAs laser emitting at 785 nm or 830 nm may be used.

[0012] In a preferred embodiment, the radial Raman probe in accordance with the present invention for use in diagnosing atherosclerosis is incorporated in a catheter of the type used for angiography, for example. It includes a balloon for displacing blood and other fluids and to position the catheter in the artery. A preferred embodiment includes a channel for balloon inflation. Further, the catheter system includes the capability for flushing away the blood temporarily with a

fluid, for example, saline. One or several optical fibers can be configured so as to direct excitation light in a radial direction, either to the side or at an angle ranging from 45°-90°. In such a preferred embodiment a balloon disposed on the side is used to contact the fibers adjacent the artery wall, and displace blood or other intervening fluids.

[0013] Alternately, the delivery fibers can be arranged to direct light in a circular pattern at an angle to the axis of the probe. The different collection fibers collect light simultaneously from different portions of the circumferential region illuminated. In this embodiment, the probe is enclosed in an inflatable balloon which is inflated before light delivery and/or collection to displace blood and other fluids. In preferred embodiments, the balloon is of a type used in arterial applications, such as, for example, angioplasty, and are made of thin material so as to allow excitation light to pass through to the artery wall, and return Raman light generated in the artery wall to pass through the balloon to the collection fibers.

[0014] The present invention includes the diagnostic classification of atherosclerotic plaques in human coronary arteries by quantitative assessment of their morphologic composition using Raman spectroscopy. The rapid and non-destructive nature of Raman spectroscopy provides the opportunity to diagnose coronary artery plaques in-vivo, when applied in a clinical setting using optical fiber technology. So used, the preferred embodiments of the present invention classify an atherosclerotic lesion, and can provide in-vivo quantitative assessment of its morphologic features, such as the presence of foam cells (FC), necrotic core (NC), and cholesterol crystals (CC), which may be used to assess plaque instability and the extent of disease progression, and thereby, the risk of life-threatening complications such as thrombosis and acute plaque hemorrhage. So used, the methods of the present invention may provide insight into as yet poorly understood dynamics in the evolution of atherosclerotic lesions and the effects of lipid-lowering and other therapies.

[0015] Chemical composition and morphology, rather than anatomy (degree of stenosis), determine atherosclerotic plaque instability and predict disease progression. In a preferred embodiment, a modification of the Raman spectroscopy reference data can also be used to identify the microscopic morphologic structures comprising the plaque, and the pathological state of the artery can be accurately assessed using a diagnostic algorithm based on the relative contribution of these microscopic morphological structures to the macroscopic arterial Raman spectrum.

[0016] In a preferred embodiment eight atherosclerotic classes are used for comparison with previous studies using the principal component analysis (PCA) and chemical reference data. These eight classes are reduced to three classes. On pathologic examination, the presence of FC, NC, and CC are significant predictors of plaque instability and disease progression. The embodiments of the present invention show that Raman spectroscopic analysis of these same morphologic structures can be used to diagnose atherosclerotic lesions in intact coronary arteries, without the need for microscopic examination. This suggests that Raman spectroscopy can provide not only quantitative chemical information, but also quantitative morphologic information regarding atherosclerotic lesion composition, such as the

presence of CC, not readily available in current diagnostic imaging techniques such as intravascular ultrasound (IVUS), magnetic resonance imaging (MRI), and angiography.

[0017] In a preferred embodiment, the spectral signatures of the cellular and extracellular morphologic components of normal and atherosclerotic arterial tissue in-situ are determined using confocal Raman microspectroscopy. The specific morphologic structures are selected because of their role in normal arterial anatomy (e.g. elastic laminae) and/or atherosclerotic plaque formation (e.g. foam cells, necrotic core, cholesterol crystals). Least-squares minimization of a linear combination of the basis spectra of 12 biochemical components provide information on the biochemical composition of the various morphologic structures. These biochemical components are selected because they were known to be present in high concentration in normal arterial tissue and/or atherosclerotic plaque (e.g. collagen, elastin, and free and esterified cholesterol) or because they are strong Raman scatterers (e.g.  $\beta$ -carotene). Glycosaminoglycans (e.g. hyaluronic acid, chondroitin sulfate, dermatan sulfate, and heparan sulfate), which may contribute 3% of artery dry mass, did not contribute significantly to the biochemical model and reference data fits, most likely because they are weak Raman scatterers (i.e. they have small Raman cross sections), and were excluded from the reference data.

[0018] The embodiments of the present invention interpret Raman spectra in terms of morphology. For example, the Raman spectra can be associated with a morphological structure, for example, a foam cell which can be associated with specific chemical compounds. Further, the number of spectra can be reduced, for example, from a large number of chemical spectra to only eight unique spectra associated with morphological structures thereby decreasing the error in the fit. The diagnostics that are available to identify and monitor vulnerable plaque using the optical fiber catheter system of the present invention include the use of chemical composition, information about the morphological structures, thickening of the intimal layer and the thinning of the overlying collagen layer. Preferred embodiments include the determination of the depth of collagen by measuring the percentage of collagen. Further, the presence of calcification is monitored and any edges are identified and located relative to the collagen as indicators of a potential rupture and blood clot. Further, the reduced fractional fit contributions of collagen fibers in non-calcified plaques is an indication of decreased plaque stability.

[0019] The foregoing and other features and advantages of the systems and methods for spectroscopy of in-vivo biological tissue will be apparent from the following more particular description of preferred embodiments of the system and method as illustrated in the accompanying drawings in which like reference characters refer to the same parts throughout the different views. The drawings are not necessarily to scale, emphasis instead being placed upon illustrating the principles of the invention.

#### BRIEF DESCRIPTION OF THE DRAWINGS

[0020] FIG. 1A graphically illustrates a comparison of theory, simulations and results for Raman emission data of turbid samples of blood tissue for the radial distribution of the Raman scattered light in accordance with a preferred embodiment of the present invention.

[0021] **FIG. 1B** graphically illustrates a comparison of simulations, theory and results for Raman emission data of turbid samples of blood tissue for angular distribution of the Raman scattered light in accordance with a preferred embodiment of the present invention.

[0022] **FIGS. 2A-2C** are graphical representations of morphological reference data of coronary arteries for a normal coronary artery, non-calcified plaque and calcified plaque, respectively in accordance with a preferred embodiment of the present invention.

[0023] **FIG. 3** is a graphical illustration of Raman morphometry of a coronary artery in accordance with a preferred embodiment of the present invention.

[0024] **FIG. 4A** is a longitudinal view of an apparatus including a probe for measuring tissue in accordance with a preferred embodiment of the present invention.

[0025] **FIG. 4B** is a transverse view of the probe illustrated in **FIG. 4A** in accordance with a preferred embodiment of the present invention.

[0026] **FIGS. 4C and 4D** are a longitudinal and transverse view respectively of an alternate embodiment of a probe for measuring tissue with a paraboloidal mirror in accordance with the system of the present invention.

[0027] **FIG. 5** graphically illustrates the transmission characteristics of the excitation and collection fibers incorporating filters with respect to the Raman shift in accordance with a preferred embodiment of the present invention.

[0028] **FIG. 6** graphically illustrates the Raman spectrum of a non-calcified atherosclerotic plaque collected in 1 second with 100 mW excitation power in accordance with a preferred embodiment of the present invention.

[0029] **FIG. 7** graphically illustrates the Raman spectrum of a normal artery in accordance with an in-vitro system preferred embodiment of the present invention.

[0030] **FIG. 8** is a schematic diagram illustrating a system for measuring tissue in accordance with a preferred embodiment of the present invention.

[0031] **FIG. 9** illustrates the excitation light diffusing through tissue in accordance with a preferred embodiment of the present invention.

[0032] **FIGS. 10A-10C** are graphical representations of the integrated radial distributions, integrated angular distributions and optimized collection efficiency for blood tissue, respectively, in accordance with a preferred embodiment of the present invention.

[0033] **FIG. 11** is a graphical representation of an excitation spot size in accordance with a preferred embodiment of the present invention.

[0034] **FIG. 12** is an illustration of a ray diagram of the distribution of excitation light in tissue in accordance with a preferred embodiment of the present invention.

[0035] **FIG. 13** is an illustration of a ray diagram of the collection efficiency of a probe in accordance with a preferred embodiment of the present invention.

[0036] **FIG. 14** graphically illustrates the collection efficiency of the probe in accordance with a preferred embodiment of the present invention.

[0037] **FIG. 15** is a partially sectioned view illustrating a portion of a coronary artery showing a probe in accordance with a preferred embodiment of the present invention.

[0038] **FIG. 16** illustrates a signal from a ball lens as a function of laser power in accordance with a preferred embodiment of the present invention.

[0039] **FIG. 17** graphically illustrates a comparison of data as collected using a probe and an experimental system of a normal aorta in accordance with a preferred embodiment of the present invention.

[0040] **FIG. 18** graphically illustrates a Raman spectrum of normal breast tissue examined with a probe in accordance with a preferred embodiment of the present invention.

[0041] **FIG. 19** graphically illustrates a comparison of Raman spectra of a malignant breast tumor as collected using a probe in accordance with a preferred embodiment of the present invention and as predicted by reference data of the present invention.

[0042] **FIG. 20** graphically illustrates a comparison of morphological reference data to calcified aorta data collected with a probe in accordance with a preferred embodiment of the present invention.

[0043] **FIGS. 21A-C** illustrate longitudinal views of alternate preferred embodiments of side-viewing probes for measuring tissue in accordance with a system of the present invention.

[0044] **FIG. 21D** illustrates a view of a preferred embodiment of a side-viewing probe delivering light imaged onto a portion of tissue and Raman light collected from the tissue in accordance with a preferred embodiment of the present invention.

[0045] **FIG. 22** is a schematic illustration of a combined Raman macrospectroscopy and confocal microspectroscopy system in accordance with a preferred embodiment of the present invention.

[0046] **FIG. 23** graphically illustrates the Raman spectra of eight selected coronary artery morphological structures in accordance with a preferred embodiment of the present invention.

[0047] **FIGS. 24A-24C** graphically illustrate the results of the fit contribution of seven morphologic structures to the calibration data set and the diagnostic algorithm classification wherein **FIG. 24A** illustrates nonatherosclerotic tissue, **FIG. 24B** illustrates noncalcified atherosclerotic plaque and **FIG. 24C** illustrates calcified atherosclerotic plaque in accordance with a preferred embodiment of the present invention.

[0048] **FIG. 25** illustrates the spectral contribution of  $\beta$ -carotene in a calibration data set in relation to three diagnostic categories, wherein the carotenoid level is expressed in arbitrary units in accordance with a preferred embodiment of the present invention.

[0049] **FIGS. 26A and 26B** graphically illustrate the results of the algorithm developed with an initial calibration data set and the results of the prospective validation data set, respectively, in accordance with a preferred embodiment of the present invention.

[0050] FIG. 27 is a schematic diagram of a system including a confocal Raman microspectrometer in accordance with a preferred embodiment of the present invention.

[0051] FIGS. 28A and 28B are a photomicrograph of internal elastic lamina in a 6- $\mu$ m unstained coronary artery section viewed under phase contrast and the Raman spectrum of the internal elastic lamina, respectively, in accordance with a preferred embodiment of the present invention.

[0052] FIGS. 29A and 29B are a photomicrograph of the tunica adventitia with collagen fibers in a 6- $\mu$ m unstained coronary artery section viewed under phase contrast and the Raman spectrum of the fibers, respectively, in accordance with a preferred embodiment of the present invention.

[0053] FIG. 30 graphically illustrates the Raman spectra of four different smooth muscle cells in the tunica media in accordance with a preferred embodiment of the present invention.

[0054] FIG. 31 graphically illustrates the Raman spectra of four fat cells (adipocytes) in the tunica adventitia in accordance with a preferred embodiment of the present invention.

[0055] FIGS. 32A and 32B are a photomicrograph of foam cells in an intimal atherosclerotic plaque in a 6- $\mu$ m unstained coronary artery section viewed under phase contrast and a Raman spectra of the foam cells and necrotic core, respectively, in accordance with a preferred embodiment of the present invention.

[0056] FIG. 33 graphically illustrates the Raman spectra of cholesterol crystals in intimal atherosclerotic plaques in accordance with a preferred embodiment of the present invention.

[0057] FIGS. 34A and 34B are a photomicrograph of the calcification in the necrotic core of an intimal atherosclerotic plaque in a 6- $\mu$ m unstained coronary artery section viewed under phase contrast and the corresponding Raman spectra in accordance with a preferred embodiment of the present invention.

[0058] FIG. 35 graphically illustrates a Raman basis spectra of the 12 biochemicals used for linear fitting to the morphologic spectra in accordance with a preferred embodiment of the present invention.

[0059] FIGS. 36A-36H provide a graphical comparison between observed data and reference data of spectra of the different morphological structures in the coronary artery in accordance with a preferred embodiment of the present invention.

[0060] FIGS. 37A-37H graphically illustrate the biochemical composition of each morphologic structure in accordance with a preferred embodiment of the present invention.

[0061] FIG. 38A graphically illustrates the results for Raman emission data of turbid samples of artery tissue for the radial distribution of the Raman scattered light in accordance with a preferred embodiment of the present invention.

[0062] FIG. 38B graphically illustrates the results for Raman emission data of turbid samples of artery tissue for angular distribution of the Raman scattered light in accordance with a preferred embodiment of the present invention.

[0063] FIGS. 38C-38E are graphical representations of integrated radial distributions, integrated angular distributions and optimized collection efficiency of artery tissue, respectively, in accordance with a preferred embodiment of the present invention.

#### DETAILED DESCRIPTION OF THE INVENTION

[0064] The present invention is directed to systems and methods for using Raman spectroscopy of tissue. A predicate for developing systems and methods for in-vivo applications using angiographic catheters to aid cardiologists in directing the appropriate treatment is the development of optical fiber probes for Raman spectroscopy capable of delivering low energy laser light to, and efficiently collecting the resulting Raman spectral signature from, in-vivo tissue. The probes in preferred embodiments are small, and use micro-optical design principles.

[0065] Methods for performing Raman spectroscopy for diagnosis and treatment of tissue are described in U.S. Pat. No. 5,615,673 issued on Apr. 1, 1997, in U.S. Pat. No. 5,304,173 issued on Apr. 19, 1994, in International Publication No. WO 92/15008, published on Sep. 3, 1992 and in International Publication No. WO 96/29925 published on Oct. 3, 1996, the entire teachings of all the references are incorporated herein by reference.

[0066] There are at least two difficulties to be overcome in producing such probes. The first is due to the spectral background signal generated in the delivery and collection fibers themselves, which may be orders of magnitude larger than the signal from the tissue site being examined. This background signal includes Raman light from the fused silica core, fluorescence from impurities and dopants used to design fibers of a particular numerical aperture (NA), as well as signal from various jacket materials. Laser light in the delivery fibers generates an intense fiber background due to the long path length traversed in the fibers, typically three to four meters. This fiber spectrum is scattered from the tissue surface and is collected, along with the tissue Raman spectrum, by the collection fibers, often masking the tissue Raman signal which is generated from only approximately 1 mm of sample due to the relatively short penetration of light into tissue.

[0067] In addition, laser light backscattered from the tissue is also collected by the collection fibers, and this scattered laser light produces an additional fiber spectrum originating in the collection fibers, which further compromises the quality of the tissue spectrum reaching the detector. In addition to obscuring and distorting the spectrum of interest, the intense fiber background adds a level of shot-noise to the signal and this noise can often be larger than the tissue Raman bands. Analyzing both delivery and collection fibers indicates that they both produce approximately equal amounts of this fiber spectral background. In a preferred embodiment, two different filters are used to suppress the undesired fiber background, one for delivery and one for collection. Further, it is desirable to terminate the delivery fibers with a short wavelength pass or band-pass filter that transmits the laser excitation light while blocking the longer wavelength spectral background generated in the delivery fibers. In a preferred embodiment, the collection fibers can be preceded by a long wavelength pass filter or notch filter

which transmits the tissue Raman spectrum while blocking laser light backscattered from the tissue. Any filters used also perform the appropriate function over a range of angles corresponding to the acceptance angle (NA) of the fibers they are coupled to.

**[0068]** The second difficulty is related to signal collection. This has two components, the first of which pertains to the inherently weak nature of the Raman effect. Approximately only one out of every billion excitation photons are converted into a Raman photon. In a preferred embodiment, a high-throughput optical probe apparatus collects signals with sufficient signal-to-noise ratio (SNR) to be useful in a clinically realistic timeframe. To be clinically useful and commercially viable, a preferred embodiment collects high SNR spectra in approximately 1-2 seconds. The second component also addresses optimization of collection which is further compromised by absorption and scattering in the tissue which results in causing the light to be widely diffused over large areas and angles.

**[0069]** In a preferred embodiment the collection ability of an optical system is limited by its throughput, approximately given by the product of area of collection (A) and solid angle ( $\Omega$ ) ( $A\Omega$ -product). The  $A\Omega$  product is conserved throughout the system. In typical Raman spectroscopy systems, throughput is determined by the spectrograph/CCD collection detection system. In a preferred embodiment, the spectrograph is  $f/1.8$  ( $NA=0.278$ ) corresponding to a solid angle of  $\Omega=0.242$ sr, with a maximal slit height of 16 mm. To achieve sufficient spectral resolution for biological Raman spectroscopy a 0.2 mm slit width is used. Therefore, the maximal area of collection is  $A=3.2$  mm<sup>2</sup>, resulting in a theoretical maximal throughput of  $A\Omega=0.77$  mm<sup>2</sup>-sr. In a preferred embodiment a CCD detector is used to ensure that the effective Raman source generated in the tissue by the incident excitation light, no matter how bright, is optimally collected. The light is considered to be emitted over a large area and  $4\pi$  solid angle but is limited by the collection angle  $27\pi$ . Therefore the optimal trade-off between collection solid angle and area is determined in preferred embodiments of the present invention.

**[0070]** In a preferred embodiment system the spectrograph/CCD is replaced by a higher throughput system. For example, one such arrangement consists of a series of dichroic beam-splitters, filters and photodiodes. The filter wavelengths are determined to optimize multivariate spectral analysis with the minimum number of wavelengths. The exact number of wavelengths and bandwidths of the detector element depend on the spectral features of the chemical/morphological structures to be sensed. Such a system results in much greater throughput than the prior art spectrograph/CCD systems and is smaller, cheaper and does not require cooling, further eliminating bulk and expense.

**[0071]** **FIGS. 1A and 1B** graphically illustrate a comparison of theory, simulations and results for Raman emission data of turbid samples of blood tissue for radial and angular distribution, respectively, of the Raman scattered light in accordance with a preferred embodiment of the present invention. Biological tissue is a collection of similar cells and the intercellular substances surrounding them. The four basic tissues in the body include epithelium tissue; connective tissues including blood, bone, and cartilage; muscle tissue; and nerve tissue. Most tissues with the exception of

the cornea, are turbid, as they exhibit a high degree of elastic scattering, due to microscopic structures and refractive index variations contained therein and thus light entering such tissue is greatly diffused. Thus, the samples are characterized as turbid samples in **FIGS. 1A, 1B, 10A-10C, 38A-38E**. In a preferred embodiment, simulations such as, for example, Monte Carlo simulations are performed to predict the spatial and radial distribution of both the excitation and the Raman scattered light. In a preferred embodiment, the radial distribution is approximately Gaussian as shown in **FIG. 1A**, while the angular distribution is Lambertian as shown in **FIG. 1B**. Using these parameters and the optical throughput theorem which includes the conservation of the product of area and solid angle of the light being transmitted through an optical system, the optimal collection area and angles are determined. It should be recognized that the product  $A\Omega$  is a constant and choosing the optimal combination of A and  $\Omega$  is important as shown in **FIGS. 10A-10C**. In a preferred embodiment collection parameters of approximately 0.35 mm radius and  $55^\circ$  are optimal for blood tissue. The optimal collection parameters for artery tissue are approximately 0.4 mm radius and  $20^\circ$ . The results of the analyses are then incorporated into an optical design program such as, for example, Zemax program to determine appropriate optics for maximal signal collection.

**[0072]** **FIG. 38A** graphically illustrates the results for Raman emission data **1360** of turbid samples of artery tissue in contrast to blood tissue described with respect to **FIG. 1A** for the radial distribution of the excitation and Raman scattered light in accordance with a preferred embodiment of the present invention. The curve **1362** illustrates the fit using a three Gaussian fit. Further, **FIG. 38B** graphically illustrates the results for Raman emission data **1360** of turbid samples of artery tissue for angular distribution of the excitation and Raman scattered light in accordance with a preferred embodiment of the present invention. Similar to **FIGS. 10A-10C** which illustrated distributions and collection efficiency for blood tissue; **FIGS. 38C-38E** are graphical representations of integrated radial distributions, integrated angular distributions and optimized collection efficiency for artery tissue, respectively, in accordance with a preferred embodiment of the present invention.

**[0073]** Optical elements are used to transfer the light collected from the tissue to the distal end of optical fibers in the probe. The proximal end of the fiber bundle is then re-shaped to match the shape, area, and NA of the spectrograph. These procedures are followed so as not to decrease light transmission efficiency, and provide effective coupling. The choice of collection fiber NA and collection fiber diameter is determined by the spectrometer NA, the desired spectral resolution, and considerations of matching optics, as well as the limitation set by filter acceptance angle. The trade-offs for the system include the spectrometer chosen, and the desired resolution determines a slit width. At the output end the collection fibers are arranged in a straight line, which is imaged onto the entrance slit by the matching optics. Considering the throughput theorem, the requirement on the collection fibers includes that the product of fiber NA and diameter equal the product of spectrometer NA and slit width. If a fiber is chosen which satisfies the stronger condition that the fiber diameter equals the slit width and the fiber NA equals the spectrometer NA, the necessity of using matching optics is eliminated and the probe is directly coupled into the spectrometer. If only the product require-

ment can be satisfied then matching optics are needed. In an alternate embodiment, spectrometers use curved slits, and the output end of the collection fibers can be modified to match any slit shape. An upper limit on the number of collection fibers is defined by the height of the fiber array image that is less than the slit height or CCD chip, whichever is less. However a smaller limitation may be set by the space available in the collection tip.

[0074] FIGS. 2A-2C are graphical representations 30, 40, 50 of the morphological models and references of the coronary artery in accordance with a preferred embodiment of the system. The studies use biochemical composition in determining plaque stability and plaque progression. The morphological factors are discussed in "Raman microspectroscopy of human coronary atherosclerosis: Biochemical assessment of cellular and extracellular morphologic structures in-situ" by Hendrik P. Buschman et al, as published in *Cardiovascular Pathology* 10 (2001) 69-82 and "Diagnosis of human coronary atherosclerosis by morphology-based Raman spectroscopy" by Hendrik P. Buschman et al, as published in *Cardiovascular Pathology* 10 (2001) 59-68, the entire teachings of which are incorporated herein by reference.

[0075] FIG. 3 is a graphical illustration 60 of Raman morphometry of a coronary artery in accordance with a preferred embodiment of the present invention. The relative fit coefficients are plotted against different conditions in the normal artery, artery having non-calcified plaque and calcified plaque.

[0076] In accordance with preferred embodiments for intravascular applications all of the parameters such as, for example, but not limited to optical filtering and high-throughput optics designed to collect from diffuse sources is accomplished without increasing the diameter of the tip, or compromising its flexibility. Many prior art commercial probes are designed to be used with 785 nm excitation. The methods of the present invention include the recognition that the fluorescence background generated in tissue with 785 nm excitation is at least four times greater than that generated with 830 nm excitation. Operating at 785 nm necessitates longer data acquisition times that is prohibitive for in-vivo applications. The longer the wavelength of operation, the better in terms of fluorescence background. In a preferred embodiment, the use of 830 nm is governed by the fundamental long wavelength limit (1100 nm) of the silicon based charge coupled device (CCD) detectors which is governed by the silicon band gap. Alternate preferred embodiments, can use 785 nm or 1064 nm excitation light with appropriate detector technology.

[0077] A preferred embodiment of the present invention includes an optical fiber Raman probe which removes the optical fiber background, limits the length of the rigid distal tip to less than a few mm and the diameter to about two mm, for example, to facilitate use in coronary artery catheterization, employs 830 nm excitation and, maximizes signal collection from diffuse sources in order to allow data collection times of a few seconds or less.

[0078] A preferred embodiment includes a rod and tube configuration in which the rod and tube of optical filter modules are coated separately which is easier than coating a single disc having two separate coatings: one in the center to filter the excitation light, and one at the edges to filter the

collected light. These embodiments are preferable to coating individual fibers because the filter can adhere better due to the increased surface area. In addition, a two-tone disc is preferable to coating a single disc because it is difficult to deposit concentric coatings on a small diameter with a smooth circular interface without gaps or overlapping regions. Further, it is difficult to place three meter fiber lengths in deposition coating chambers. Each filter can include a stack of dielectric thin films. Such thin film filters can be fabricated by Research Electro-Optics Inc., Boulder, Colo.

[0079] FIGS. 4A-4B show a longitudinal and transverse view, respectively, of a preferred embodiment apparatus including a Raman probe. The apparatus 70 includes a two piece multiple, for example, dual wavelength micro-optical dielectric filter module for minimizing and preferably eliminating fiber Raman background in the delivery and collection fibers. This module consists of a rod 82 carrying the excitation dielectric filter coating on one plane face, fitted into the tube 78 carrying the collection dielectric coating on one plane face of the tube. Rods and tubes are used in the embodiment that are made of either sapphire or fused silica which are separately coated with their respective filters prior to assembly. The rod is wrapped or coated with a thin sheet of metal 80 to provide optical isolation between the components. The module is then placed at the distal end of the probe between the fiber bundles and a lens system for collimating the light beams having a lens 86 such as, for example, a ball lens. The lens collects light from high angles and a large area effectively overlapping excitation and collection regions. The ball lens can be fabricated and supplied by Edmund Industrial Optics, New Jersey. In a preferred embodiment, sapphire lenses that are coated with anti-reflection coatings and having an appropriate index for angular acceptance, for example, 1.77 is fabricated by MK Photonics, Albuquerque, N. Mex. Although it is expensive to obtain high quality interference filters at this scale, the cost of the filters is independent on the number of pieces coated, thus it is possible to coat many filters at once, thereby reducing the construction cost of each probe. Furthermore, through additional coating runs, the filter size can be adjusted to create smaller diameter probes for various applications. In a preferred embodiment, the filters are deposited on sapphire or quartz rods and tubes for proper registration with fibers.

[0080] FIGS. 4C and 4D show a longitudinal and transverse view, respectively, of an alternate preferred embodiment having a paraboloidal mirror disposed in the lens system. The collection angle can be in the range of 0 to approximately 55° with a collection diameter of approximately 1 mm. The paraboloidal mirror collects light from a wider angle and a larger area.

[0081] Transmission characteristics of the excitation and collection fibers incorporating these filters are shown in FIG. 5 wherein  $0 \text{ cm}^{-1}=830 \text{ nm}$ .

[0082] In accordance with preferred embodiments, the choice of fiber diameter and numerical aperture (NA), is dictated by the following considerations, for example, that the fiber Raman signal (produces unwanted background) is proportional to the square of the NA, and independent of the fiber diameter, that low NA is better, and that diameter has no effect.

**[0083]** For the excitation fiber, using a lower NA fiber is useful, however there are issues to contend with. At the input end it makes coupling the energy into the fiber more difficult. In a preferred embodiment, when exciting with a laser with a low beam divergence, reasonable care in mounting the fiber and the matching optics avoids this problem. At the output end the beam is more confined. This makes the filter construction simpler and more efficient, but illuminating a larger area in order to minimize the potential of tissue damage due to confining the power of the incident beam to a smaller area (spot) can also be important. However, even a smaller diameter spot of laser excitation light incident on the tissue spreads to cover a larger area typically  $\frac{1}{2}$ -1 mm diameter because of the aforementioned elastic scattering turbidity, thus mitigating this consideration. In a preferred embodiment a larger diameter fiber, or a distributed array of smaller fibers is used. Preferred embodiments balance the fact that low NA fibers typically exhibit an increased spectral background caused by dopants used in the core and cladding of the fiber to reduce the NA, and hence, use a modest core size and NA for the excitation fiber.

**[0084]** For the collection fibers the situation is different. The Raman energy collected is proportional to the square of the NA. Therefore, from a signal-to-background analysis there is an advantage in using high NA collection fibers the size of which is limited by the spectrograph NA. Here, the best choice of fiber NA and fiber diameter is determined by the spectrometer NA, the desired spectral resolution, and considerations of matching optics, as well as the limitation set by filter acceptance angle. In a preferred geometry, one or a few number of delivery fibers are used as the energy of the laser source can be efficiently coupled into the delivery fiber/fibers. However, a greater number of collection fibers is important to increase the area of collection as shown in **FIG. 4B**. The area for collection is maximized since it is important to optimize collection of Raman light. Taking all these considerations into account, it is best to use as much of the available cross-sectional area of the optical fiber probe for collection fibers, keeping the number and diameter of the delivery fiber(s) to a minimum.

**[0085]** Preferred embodiments include the following trade-offs. For the spectrometer chosen, the desired resolution determines a slit width. Considering the throughput theorem again, the requirement on the collection fibers is that the product of fiber NA and diameter equal the product of spectrometer NA and slit width. If it is possible to choose a fiber which satisfies the stronger condition that the fiber diameter equals the slit width and the fiber NA equals the spectrometer NA, the necessity of using matching optics is eliminated and the probe can be directly coupled into the spectrometer. If only the product requirement can be satisfied then matching optics are needed. At the output end the collection fibers are arranged in a straight line, which is imaged onto the entrance slit by the matching optics. Occasionally spectrometers use curved slits; the output end of the collection fibers can be modified to match any slit shape. An upper limit on the number of collection fibers is that the height of the fiber array image be less than the slit height or CCD chip, whichever is less. However a smaller limitation may be set by the space available in the collection tip.

**[0086]** In a preferred embodiment, the fiber section of the probe includes a single central excitation fiber with an NA of 0.22 and a core diameter of 200  $\mu\text{m}$ . The buffer of the fiber

is matched to the diameter of the excitation filter rod, to facilitate proper fiber/filter registration, and has an aluminum jacket to provide optical isolation from the collection fibers. The 200  $\mu\text{m}$  core diameter collection fibers are arranged in two different geometries in two alternate embodiments. The first embodiment consists of two concentric rings of 10 and 17 fibers for the inner and outer ring, respectively. The second embodiment has a single ring of 15 collection fibers. Although the second design has a slightly reduced collection efficiency, it is more flexible and still able to collect a high SNR spectra in short exposure times. The collection fibers all have an NA of 0.26 so that they are  $f/\#$ -matched to the spectrograph for optimal throughput as illustrated in **FIGS. 4A-4D**. The diameter of the probe, in a preferred embodiment is less than 2 mm for access to coronary arteries.

**[0087]** A preferred embodiment provides flexibility with respect to the particular choice of optics for high-throughput collection so that a variety of optical elements can be used to collect the desired  $A\Omega$ -product. In a preferred embodiment, a ball lens provides highly efficient collection for front viewing optical fiber probes that closely match calculated collection over a radius of 0.35 mm for blood tissue (0.4 mm for artery tissue) while still collecting over large angles as shown in **FIGS. 1A-1B** and **4A-4B**. Collection efficiencies greater than 30% are achieved if a small space is maintained between the sample and lens, greater than 10% when in contact with tissue, the likely and more reproducible in-vivo geometry. An example of the high quality spectra obtained with a preferred embodiment with the probe in contact with tissue is presented in **FIG. 6** which shows the Raman spectrum of a non-calcified atherosclerotic plaque collected in 1 second with 100 mW excitation power. In contrast, **FIG. 7** shows the spectrum of a normal artery taken with another preferred embodiment system in 10 seconds with the same excitation power.

**[0088]** **FIG. 8** is a schematic diagram illustrating a system for measuring tissue in accordance with a preferred embodiment of the present invention. A light source **206** emitting at a wavelength longer than 750 nm, such as an argon pumped Ti: sapphire laser system or a diode laser is used. The diode laser may be an InGaAs laser emitting at 785 nm or 830 nm, such as, for example, fabricated by Process Instruments, Salt Lake City, Utah. The laser output is band pass-filtered and is coupled into the delivery optical fibers which are included in the probe **204**. The probe **204** is inserted into an artery **202** to diagnose and possibly treat the buildup of, for example, plaque in the artery. **FIG. 15** is a partially sectioned view of a portion of coronary artery showing a probe in accordance with a preferred embodiment of the system of the present invention. The system may include a guidewire, and a guide catheter for threading through the large arteries. In a preferred embodiment, in an artery that is partially blocked by fatty material **416**, the guide wire is first extended into the artery followed by the catheter which includes the balloon **420**. A probe assembly is housed in the tip of the catheter and has a collection window **418**. Once the balloon has entered the artery **414**, the probe assembly provides a surgeon with a cross-sectional view of the artery. The balloon temporarily blocks blood flow providing a clear field of view, stabilizes the probe and minimizes effects of cardiac motion. Fluoroscopic markers may be used in preferred embodiments. The light is incident on the tissue and Raman-scattered light from the tissue is collected by the collection optical fibers. The

collected light is notch-filtered and projected onto an entrance slot of a spectrophotometer. The notch filter removes Rayleigh—scattered laser light. Inside the spectrograph, a grating disperses light onto a CCD detector **228**. The CCD interface and data storage and processing is provided in a computer such as a personal computer. A program such as Winspec Software provided by Princeton Instruments can be used to connect the CCD interface to the personal computer which performs the data processing and storage function. In alternate embodiments, the Labview program by National Instruments, Austin, Tex., is used to connect the CCD interface to the personal computer. Raman signals are read from the CCD, collected by the computer and stored on a computer readable media for later analysis or may be used for real time analysis in a clinical setting.

[**0089**] **FIG. 9** illustrates the excitation light diffusing through tissue in accordance with a preferred embodiment of the present invention. **FIGS. 10A-10C** are graphical representations of the integrated radial distributions, integrated angular distributions and optimized collection efficiency, respectively, for blood tissue in accordance with a preferred embodiment of the present invention. **FIG. 10C** illustrates the collection efficiency by varying  $A$  and  $\Omega$  illustrated in **FIGS. 10A and 10B**, respectively, but keeping the product  $A\Omega$  constant and equal to that of the spectrograph. By the throughput theorem, the étendue is conserved where étendue is the product of area and solid angle. The radial and angular distributions are integrated and their product determines the optimization curve **300**. The collection optics are designed to perform at the maximum of the efficiency curve **300**. Similar graphical illustrations for artery tissue are provided in **FIGS. 38C-38E**.

[**0090**] **FIG. 11** is a graphical representation **320** of an excitation spot diameter in accordance with a preferred embodiment of the present invention. **FIG. 12** is an illustration of a ray diagram **340** of the distribution of excitation light in tissue in accordance with a preferred embodiment of the present invention. **FIG. 13** is an illustration of a ray diagram **360** of the collection efficiency of a probe in accordance with a preferred embodiment of the present invention.

[**0091**] **FIG. 14** graphically illustrates the collection efficiency of the probe in accordance with a preferred embodiment of the present invention. The efficiency from a measured distribution for tissue and air is illustrated. All components of the probe are constructed of medical grade materials that can withstand standard cold gas, ethylene oxide sterilization. Alternate sterilization methods as provided by Steris Corporation of Ohio can be used such as, for example, a low temperature sterile processing system. The filter module in the probe tip is assembled and attached to the fiber bundle using high purity sodium silicate as an index matching cement. The advantages of sodium silicate as an index matching cement in Raman spectroscopy are unique and its utility goes beyond the present application. The advantages include producing no interfering Raman spectrum, having an index of refraction close to that of fused silica, thereby greatly reducing the reflection losses from mating surfaces, having a low optical absorption in the near IR, so it introduces no appreciable absorption losses, having cementing properties that facilitate the assembly of the small optical components involved, and it is an article accepted in commerce with uses in many industrial applications.

[**0092**] Sodium silicate is a ternary compound, created by mixing various combinations of water, silicon dioxide and sodium hydroxide, in the alternative sodium oxide. The optical and mechanical properties of the end product can be adjusted by varying these ratios. The other alkali silicates have similar properties, for example, lithium silicate, potassium silicate and can also be used in certain applications.

[**0093**] It is important not to have any adherents between the ball lens and the filters so that there is no index matching that can compromise the lensing effect provided by the curvature of the lens. The lens is secured with a crimped retaining sleeve and sealed with medical grade epoxy to prevent fluid from leaking into the probe tip in accordance with a preferred embodiment of the present invention.

[**0094**] The modular nature of the preferred embodiment probe is very versatile and can accommodate many optical embodiments. Additional embodiments for side-viewing probes as well as other front viewing embodiments for alternate applications are included in the systems of the present invention. For example the use of an angled and mirrored ball lens, a prism, or a micro-optical paraboloidal mirror allows efficient side-viewing probes. A tapered tip allows incorporation into needle probes for optical breast biopsies and a slightly smaller diameter in an alternate preferred embodiment allows breast analysis through ductoscopy. Other potential uses are for skin analysis, transcutaneous blood analyte monitoring, and gastrointestinal cancer evaluation.

[**0095**] **FIG. 16** illustrates a signal **450** from a ball lens and function of laser power in accordance with a preferred embodiment of the present invention. The front-viewing Raman probe uses a sapphire ball lens to focus the excitation light and to collect the Raman signal from the tissue. The Raman spectrum from the sapphire lens can be used as an internal standard to calibrate collected signals relative to the excitation laser power, thereby obtaining intensity information. This intensity information is not typically exploited in biological Raman spectroscopy, but can provide enhanced diagnostic power. The graphical plot is generated using data taken with a preferred embodiment Raman probe and a clinical Raman system and represents the magnitude of the signal from the sapphire lens as a function of excitation power while the probe is held in the air. It is indicative of a natural internal standard for measuring power delivered to tissue using a preferred embodiment of the present invention.

[**0096**] **FIG. 17** graphically illustrates a comparison of data from a normal artery collected using a preferred embodiment probe **472** and an experimental system **474**. To demonstrate and verify the function of the Raman probe, similar types of tissue are examined. It is demonstrated that similar spectra are obtained, and the signal-to-noise ratio (SNR) of the spectra is also examined, which is an indication of system performance as greater SNR translates to a system having less noise and indicates better performance.

[**0097**] **FIG. 18** graphically illustrates a Raman spectrum **490** of normal breast tissue examined with a probe in accordance with the present invention. Tissues other than an artery have been examined to demonstrate that the probes have multiple uses for disease diagnosis. The probes can be used in ductoscopy procedures for early diagnosis of breast cancer.

[0098] FIG. 19 graphically illustrates a comparison of Raman spectra of a breast tumor which is diagnosed as being malignant in accordance with a preferred embodiment of the present invention and as predicted by reference data of the present invention. The data 502 as collected using a preferred embodiment probe is compared to data 504 generated by reference data. The reference data coefficients are tabulated in Table 1.

TABLE 1

Component	Coefficient (%)
Calcium oxalate	11
Calcium hydroxyapatite	14
Cholesterol	2
Water	0
$\beta$ -carotene	0
Fat	15
Collagen	45
Nucleus	0
Cytoplasm	12

[0099] FIG. 20 graphically illustrates a comparison of morphological reference data to calcified aorta data collected using a probe in accordance with a preferred embodiment of the present invention. FIG. 20 illustrates the Raman spectrum 522 of a calcified aorta obtained with the Raman probe and a clinical Raman system in 1 second with 100 mW excitation power. A fit with morphological reference data is shown as spectrum 524. The residual spectrum 526 is plotted below on the same scale. The lack of features in the residual indicate a high level of agreement between the observed data and referenced data, proving that the reference data in accordance with preferred embodiments of the present invention developed with the experimental in-vitro system can be applied to data taken with the preferred embodiment Raman probes. Also of note is that there are no features corresponding to any probe background in the residual spectrum 526 indicating that any remaining, unfiltered background noise can be accurately removed. Further, the Raman spectra obtained from diseased artery does not diffuse as much in comparison to spectra obtained from normal artery, thus providing a spectra with a better level of signal-to-noise ratio (SNR). It should be noted that the SNR is affected by both Raman cross-sections of the tissue and the distribution of light.

[0100] In a preferred embodiment, the non-axial Raman probe in accordance with the present invention for use in diagnosing atherosclerosis is incorporated in a catheter of the type used for angiography, for example. It includes a balloon for displacing blood and other fluids and to position the catheter in the artery. A preferred embodiment includes a channel for balloon inflation. Further, the catheter system includes the capability for flushing away the blood temporarily with a fluid, for example, saline. One or several optical fibers can be configured so as to direct excitation light in a non-axial direction, either to the side or at an angle ranging from 45°-90°. In such a preferred embodiment a balloon disposed on the side is used to contact the fibers adjacent the artery wall, and displace blood or other intervening fluids.

[0101] Alternately, the delivery fibers can be arranged to direct light in a circular pattern at an angle to the axis of the probe. The different collection fibers collect light simultaneously from different portions of the circumferential region

illuminated. In this embodiment, the probe is enclosed in an inflatable balloon which is inflated before light delivery and/or collection to displace blood and other fluids. In preferred embodiments, the balloon is of a type used in arterial applications, such as, for example, angioplasty, and are made of thin material so as to allow excitation light to pass through to the artery wall, and return Raman light generated in the artery wall to pass through the balloon to the collection fibers.

[0102] FIG. 21A illustrates a longitudinal view 550 of an alternate preferred embodiment of the side-viewing probe for measuring tissue in accordance with a system of the present invention. The embodiment includes a modified axicon 556 in which the surfaces of the angled sides are made elliptical. FIGS. 21B and 21C are preferred alternate embodiments including at least two different radii of curvature on the angled surface to provide circumferential imaging. Circumferential imaging can be obtained in an embodiment by providing beams ranging from approximately 45°-90° angle and rotating the probe to get a circumferential image. Alternatively, delivery fibers can provide light to the tissue and image, such as, for example, six images are collected in collection fibers to get a circumferential image. In one preferred embodiment, the volume between the filters 554 and the angled portion of the axicon 556 comprises solid glass, preferably sapphire wherein the redirection of light occurs via total internal reflection.

[0103] In the alternate preferred embodiment as illustrated in FIG. 21B the angled surfaces 562 of the axicon 556 are mirrored which allow for reflections. The laser light is directed radially or non-axially onto the tissue 564. Further, the surface 565 is elliptical and fabricated using sapphire. The volume between the filters 554 and the axicon 556 may either be filled or empty. This embodiment as illustrated in FIG. 21C provides an open central channel 558, 566 that can be used for flushing fluid, for example, saline into the artery or to inflate a balloon to temporarily block blood flow while data for a spectrum is being acquired. If a central channel 558, 566 is used then the probe includes placing several excitation fibers around the circumference of the central channel. The foci of the axicon can be adjusted. The rod-in-tube geometry of filters described in previous embodiments are modified to a tube-in-tube geometry, i.e., a central tube for the excitation filters with a hole in the middle for the central channel and an outer tube for the collection filters.

[0104] FIG. 21D illustrates a view of a preferred embodiment of a side-viewing probe, or non-axial viewing probe, and catheter 610 delivering light onto a portion of tissue 612 and Raman light collected from the tissue and reimaged on a point at a second surface in accordance with a preferred embodiment of the present invention. The side-viewing probe includes an inflatable balloon 614 or flexible wire installed adjacent the side-looking element across from its viewing aperture. Upon balloon inflation or wire inflexion, the aperture is pressed into contact with the artery wall 616 displacing blood and/or establishing a well-defined collection geometry.

[0105] As discussed briefly hereinbefore, recent studies have shown that chemical composition and morphology, rather than anatomy (degree of stenosis), determine atherosclerotic plaque instability and predict disease progression

and the risk of life-threatening complications such as thrombosis and acute plaque hemorrhage. For example, the presence of cholesterol esters may soften the plaque, whereas crystalline-free cholesterol may have the opposite effect. Raman spectroscopy can identify cholesterol esters from free cholesterol as illustrated in **FIGS. 35F and 35G**. Prior art clinical diagnostic techniques provide accurate assessment of plaque anatomy, but have limited capability to assess plaque morphology in-vivo. Further, prior art diagnostic imaging techniques such as intravascular ultrasound (IVUS), MRI, and angiography provide predominantly anatomic information about the extent of luminal stenosis, but yield only limited information about lesion composition. Coronary angiography, still the "gold standard" for diagnosing coronary artery disease, shows the degree of luminal stenosis, but provides no chemical or morphologic information about the plaque. In fact, unstable atherosclerotic plaques are often "silent" on angiography. IVUS, the most accurate and quantitative technique currently in clinical use, uses the reflection of acoustical waves delivered by an intravascular catheter to probe tissue density and provide imaging information. It has advanced the understanding of atherosclerosis significantly by demonstrating extensive atherosclerosis in coronary arteries that appear normal on angiography. However, although IVUS can identify the presence of an atheroma core, it cannot specifically identify foam cells (FC) or cholesterol crystals (CC) and does not provide any chemical information. MRI has the advantage of being a noninvasive technique, and uses radio waves generated by applying a magnetic field gradient to again probe tissue density and provide imaging information. Like IVUS, it can be used to analyze anatomy and, to a lesser extent, morphology. However, conventional proton MRI techniques used clinically largely ignore and often suppress the chemical shift information. Thus, currently plaque morphology and chemical composition can only be assessed by microscopic examination of excised tissues after endarterectomy or atherectomy.

**[0106]** The preferred embodiment of the present invention includes a method for a morphology-based diagnosis of atherosclerosis in the coronary arteries using Raman spectroscopy that can potentially be performed in-vivo using optical fiber technology. In a preferred embodiment, Raman tissue spectra are collected from normal and atherosclerotic coronary artery samples in different stages of disease progression (n=165) from explanted transplant recipient hearts (n=16). Raman spectra from the elastic laminae (EL), collagen fibers (CF), smooth muscle cells (SMC), adventitial adipocytes (AA) or fat cells, foam cells (FC), necrotic core (NC), cholesterol crystals (CC),  $\beta$ -carotene containing crystals ( $\beta$ -C), and calcium mineralizations (CM) are used as basis spectra in a linear least squares-minimization (LSM) model to calculate the contribution of these morphologic structures to the coronary artery tissue spectra. The preferred embodiment includes a diagnostic sequence of instructions that uses the fit-contributions of the various morphologic structures to classify 97 coronary artery samples in an initial calibration data set as either nonatherosclerotic, calcified plaque, or noncalcified atheromatous plaque. The sequence of instructions correctly classifies 64 (94%) of 68 coronary artery samples prospectively. Raman spectroscopy provides information about the morphologic composition of intact human coronary artery without the need for excision and microscopic examination. Thus, a preferred embodiment

uses Raman spectroscopy to analyze the morphologic composition of atherosclerotic coronary artery lesions and assess plaque instability and disease progression in-vivo.

**[0107]** The present invention includes acquiring quantitative morphologic information regarding lesion composition from coronary arteries by Raman spectroscopy using a modification of mathematical reference data. This morphologic information can be used for diagnostic purposes. The chemical and morphologic information obtained by Raman spectroscopy can be the basis of a diagnostic assessment of human coronary artery disease.

**[0108]** In principal, both quantitative chemical and morphologic information regarding atherosclerotic lesion composition can be obtained from the same Raman spectrum. A preferred embodiment of the present invention analyzes coronary artery tissue by modeling of Raman tissue spectra using the spectra of morphologic structures rather than biochemical components as a basis set. Basis spectra for the reference data are obtained from morphologic structures commonly observed in the normal artery wall and in atherosclerotic plaque, including collagen fibers (CF), the internal and external elastic laminae (EL), smooth muscle cells (SMC), adventitial adipocytes (AA) or fat cells, foam cells (FC), necrotic core (NC), cholesterol crystals (CC),  $\beta$ -carotene containing crystals ( $\beta$ -C), and calcium mineralizations (CM). These basis spectra can then be used to linearly fit the spectra of an initial calibration set of coronary artery specimens. Using the fit-contributions of the various morphologic structures, an algorithm is included in a preferred embodiment that classifies the arteries as atherosclerotic or nonatherosclerotic as in a biochemical model. The diagnostic performance of the preferred embodiment can be tested by applying morphology-based reference data, to a second, prospective, validation set of coronary arteries.

**[0109]** In a preferred embodiment, tissue preparation includes obtaining from explanted recipient hearts, within 1 hour after heart transplantation, human coronary artery samples (n=200) from 16 patients, exhibiting different stages of atherosclerosis. Seven patients had heart failure due to dilated cardiomyopathy and nine due to severe ischemic heart disease. Immediately after dissection from the explanted heart, the artery segments were rinsed with neutral-buffered saline solution, snap-frozen in liquid nitrogen, and stored at  $-85^{\circ}$  C. until use. The artery samples were collected in two sets, the first containing 113 (calibration set) and the second, 87 samples (prospective validation set).

**[0110]** These artery samples can be and were used for macroscopic and microscopic Raman spectroscopy studies. For the macroscopic study, the samples (**97** and **68**, from the first and second sets, respectively) were warmed passively to room temperature, cut open longitudinally, placed in an aluminum holder with the lumen side upwards, and examined under  $\times 10$  magnification for selection of the region to be evaluated. After spectroscopic examination, each spot interrogated was marked with a small spot of colloidal ink, and fixed in 10% neutral-buffered formalin.

**[0111]** For the collection of the Raman spectra using a microspectrometer unstained, transverse tissue sections (6-8  $\mu$ m) were cut from the coronary artery samples. Four sections of each sample were mounted on glass microscope slides and stained for light microscopic examination, whereas serial unstained transverse sections were mounted

on BaF<sub>2</sub> or MgF<sub>2</sub> flats (International Scientific Products, Tarrytown, N.Y. and Spectra-Tech, Stamford, Conn.), kept moist with phosphate buffered saline (pH 7.4), and transferred to the microscopic stage for spectroscopic experiments. No coverslip was used. Under white light illumination, the major morphologic structures were selected and recorded on videotape under  $\times 10$  and  $\times 63$  magnification.

[0112] The formalin-fixed macroscopic tissue samples were processed, paraffin-embedded, and cut through the marked locations in 5- $\mu\text{m}$  thick sections, stained with hematoxylin and eosin, and examined by two experienced cardiovascular pathologists. The tissue sections were classified according to the updated Systemized Nomenclature of Human and Veterinary Medicine (SNoMed). The samples in both the calibration and validation data sets were diagnosed as either (1) normal (n=12 and 1), (2) intimal fibroplasia (n=61 and 25), (3) atherosclerotic plaque (n=3 and 0), (4) atheromatous plaque (n=6 and 16), (5) calcified atherosclerotic plaque (n=1 and 3), (6) calcified atheromatous plaque (n=7 and 13), (7) calcified fibrosclerotic plaque (n=5 and 10), or (8) calcified intimal fibroplasia (n=2 and 0, respectively). Because some of these categories had small sample numbers, the eight categories were condensed into three diagnostic classes for the development of a diagnostic algorithm: Class I, nonatherosclerotic tissue (Categories 1 and 2; n=73 and 26); Class II, noncalcified atherosclerotic plaque (Categories 3 and 4; n=9 and 16); and Class III, calcified atherosclerotic plaque (Categories 5-8; n=15 and 26).

[0113] The macroscopic and microscopic Raman spectra were obtained using the Raman spectroscopy system shown in FIG. 22. Near-infrared (NIR) laser light (830 nm) is generated by an Ar<sup>+</sup>-pumped Ti: sapphire laser system 572, 574 (Coherent Innova 90/Spectra Physics 3900S, Coherent, Santa Clara, Calif.). The laser output is band pass-filtered (Kaiser Optical Systems HLB, Ann Arbor, Mich.) and, by insertion of a prism 578, either projected onto the tissue sample in the macroscopic setup, or projected into a confocal microscope 600 and focused onto the tissue section with a  $\times 63$  infinitely corrected water immersion objective (Zeiss Achroplan, NA 0.9). In the macroscopic setup, Raman-scattered light from the tissue (sampling volume 1-2 mm<sup>3</sup>) is collected with a lens, Notch-filtered 588, and focused onto the entrance slit of a Chromex 250IS/SM spectrophotometer (Chromex, Albuquerque, N. Mex.). In the microscope setup (sampling volume approximately 2 $\times$ 2 $\times$ 2  $\mu\text{m}^3$ ), the Raman light scattered from the tissue is collected with the same objective that is used to focus light onto the sample, passed through a pinhole (giving the system its confocal characteristic), Notch-filtered, and projected onto the entrance slit of the spectrophotometer. Inside the spectrophotometer 580, a grating disperses light onto a deep-depletion CCD detector 582 (Princeton Instruments, Princeton, N.J.) cooled to -110° C. The CCD interface (ST130, Princeton Instruments), along with data storage and processing, is rendered on a personal computer 584.

[0114] For the macroscopic measurements, the laser power is 350 mW, and the signal collection time is in the range 10-100 s. For the microscopic measurements, the laser power is 80-120 mW, and the signal collection time is 60-360 s, and the Raman spectra is collected in the range between 400 and 2000 cm<sup>-1</sup> (resolution 8 cm<sup>-1</sup>).

[0115] Each spectrum is frequency-calibrated and corrected for chromatic variations in spectrometer system detection. A fourth-order polynomial is fit to each spectrum and subtracted from the spectrum to correct for remaining tissue fluorescence. The macroscopic tissue spectra can be modeled in the 680-1800 cm<sup>-1</sup> Raman shift range as a linear combination of the morphologic structure basis spectra by LSM. This Raman shift range is chosen, because this range contains the most spectral information.

[0116] The morphologic structure Raman spectra can be normalized with respect to their maximum peak intensity. All spectra in the two data sets can be modeled accurately with the final set of eight morphologic basis spectra. The Raman spectral reference data calculated the fractional fit-contribution of seven of the morphologic structures. The eighth structure,  $\beta$ -carotene, is an intense Raman scatterer that often contributes to coronary artery Raman spectra, but is present only in low concentrations. For this reason, its spectrum is included in the spectral reference, but no fractional fit-contribution is calculated.

[0117] In calcified atherosclerotic plaques, CM often occupy large volumes of the tissue examined by Raman spectroscopy. To obtain information about the remaining noncalcified regions, and to compare the morphologic structure fractional fit-contributions among the different disease classes, the spectra of calcified plaques are renormalized, neglecting the contribution of calcium mineralization, and the morphologic structure fractional fit-contributions of the noncalcified regions (denoted by X<sub>NCR</sub>) is calculated.

[0118] The relative fit-contribution of each morphologic structure to the spectra in the calibration data set is used to develop the algorithm or sequence of instructions to classify the tissue into one of the three diagnostic classes. The method of logistic regression can be used to generate a discriminant score, R<sub>1</sub>, based on a linear combination of relative fit-contributions (C<sub>1</sub>) of each morphologic structure I as R<sub>1</sub>= $\alpha_1 + \beta_{11}C_1 + \beta_{21}C_2 + \dots$  with  $\alpha_i$  being a constant and  $\beta_{ii}$  an adjustable coefficient for each morphologic structure. This method is chosen over discriminant analysis, because logistic regression does not make any assumptions about the normality of the fit-coefficients.

[0119] Using maximum likelihood estimation with an analytical tool, for example, the software package STATA (Release 5.0, Stata, College Station, Tex.), the probability that an artery sample j is nonatherosclerotic (P<sub>ji</sub>), or contains a noncalcified atherosclerotic plaque (P<sub>jiII</sub>), or contains a calcified atherosclerotic plaque (P<sub>jiIII</sub>) is determined as

$$P_{ji} = \frac{1}{1 + e^{R_{ji1}} + e^{R_{ji2}}} \quad (1)$$

$$P_{jiII} = \frac{e^{R_{ji2}}}{1 + e^{R_{ji1}} + e^{R_{ji2}}}, \text{ and } P_{jiIII} = 1 - P_{jiI} - P_{jiII} \quad (2)$$

[0120] which sum to one. Furthermore, using a likelihood-ratio test on the initial calibration data set, it can be determined which morphologic structure relative fit-contributions are significant for diagnosis, and what diagnostic thresholds

for these relative fit-contributions correctly classify the most samples. The algorithm so developed can then be used to prospectively classify the artery samples in the second validation data set.

[0121] To determine the level of error in the reference data, it is necessary to analyze the signal/noise ratio (SNR) of the spectra being used. Because the microscopic Raman spectra of the morphological reference data can be collected for arbitrarily long times, they are virtually noise-free as illustrated in FIG. 23 which graphically illustrates the Raman spectra of eight selected coronary artery morphological structures in accordance with a preferred embodiment of the present invention. Therefore, the limiting source of error in the reference is due to noise in the macroscopic spectra of the intact arteries. The in-vitro system is shot noise-limited, and therefore, the noise for any given sample is equal to the square root of the signal. Following standard multivariate analysis techniques, the concentration error is proportional to the noise in the spectrum.

$$E=N \times B \quad (3)$$

[0122] where  $B=P^T(PP^T)^{-1}$ , is the calibration vector for the morphologic basis spectrum of interest, and N is the noise in the sample.

[0123] FIGS. 2A-2C described hereinbefore show macroscopic Raman spectra collected from coronary artery samples representing each of the three diagnostic classes (normal coronary artery (FIG. 2A), noncalcified atherosclerotic plaque (FIG. 2B), and calcified atherosclerotic plaque (FIG. 2C)), together with LSM reference data. The solid lines are the macroscopic spectra and the dotted lines are indicative of the reference data. Residual (data minus the fit) are shown on the same scale. For all spectra, the calculated fit agrees well with the measured spectrum, which suggests that the morphologic basis spectra are a reasonably complete representation of the Raman spectra of the macroscopic tissue samples.

[0124] The Raman spectra of all 97 coronary artery samples in the calibration data set, which were classified by a pathologist into one of the three diagnostic classes, can be analyzed in the same way. The mean  $\pm$  standard error of the mean for the relative fit-contribution of all eight selected morphologic structures in nonatherosclerotic tissue (I), noncalcified atherosclerotic plaque (II), and calcified atherosclerotic plaque (III) are shown in FIGS. 24A-24C, respectively. These figures clearly show that Raman spectroscopic modeling is able to detect morphologic changes in coronary artery tissue. The morphologic Raman reference data showed, as expected, that nonatherosclerotic tissue consisted mainly of AA, CF, EL, and SMC (FIG. 24A). In nonatherosclerotic artery, the intima is thin and therefore, the contribution of the adventitial layer (which contains a relatively large amount of adipose tissue) to the spectroscopically examined tissue volume is large, because the NIR laser light penetrates through the entire vessel wall. In noncalcified and calcified atherosclerotic plaque, the morphologic Raman reference data revealed a dramatic change of the morphologic composition with progression of disease. In noncalcified atherosclerotic plaques, where the intima is thickened, the AA contribution decreased, whereas the contribution of FC/NC and CC increased (FIG. 24B) due to accumulation of lipids in the plaque. Raman spectra of calcified atherosclerotic plaques are dominated by the CM contribution (FIG. 24C). The contribution of  $AA_{NCR}$  and

$CF_{NCR}$  in calcified atherosclerotic plaque is larger than that of AA and CF in noncalcified atherosclerotic plaque. The reduced  $CF_{NCR}$  in non-calcified plaques is an indication of decreased plaque stability.

[0125] Although the concentration of  $\beta$ -carotene in arterial tissue is low, the modeling outcome showed large differences in the contribution of carotenoids among the disease classes as illustrated in FIG. 25. The largest contribution is found in noncalcified atherosclerotic plaques, since  $\beta$ -carotene is a lipophilic substance that dissolves easily in the NC.

[0126] Using logistic regression, it is determined that an optimal separation of the data into three diagnostic classes can be obtained using the fit-contributions of CM and  $FC/NC_{NCR}+CC_{NCR}$ , with  $P<0.0001$  using a likelihood-ratio test. In addition, the likelihood ratio test determined that no improvement in classification resulted from inclusion of any of the remaining morphologic structures ( $P<0.05$ ). The discriminant scores are determined to be  $R_{j1}=-420.4+1870.0 \times (FC/NC_{NCR}+CC_{NCR})-6094.3 \times CM$ , and  $R_{j2}=-8.3+23.3 \times (FC/NC_{NCR}+CC_{NCR})+47.6 \times CM$ .

[0127] The fit-contributions of CM and  $FC/NC_{NCR}+CC_{NCR}$  of each artery sample can be plotted in a decision diagram as illustrated in FIG. 26A, using the corresponding  $R_1$  and  $R_2$  values. The border separating the regions of nonatherosclerotic tissue and noncalcified atherosclerotic plaque is given by  $PI=PII$ , which is a line described by the equation  $CM=-0.07+0.31 \times (FC/NC_{NCR}+CC_{NCR})$ . The border separating the regions of nonatherosclerotic tissue and calcified atherosclerotic plaque is given by  $PI=PIII$ , and has the equation  $CM=0.17-0.48 \times (FC/NC_{NCR}+CC_{NCR})$ . The line separating the regions of noncalcified atherosclerotic plaque and calcified atherosclerotic plaque is given by  $PII=PIII$ , and has the equation  $CM=-0.07+0.30 \times (FC/NC_{NCR}+CC_{NCR})$ . For 95 of the 97 (98%) samples in the initial calibration data set, the decision determined by the Raman-based diagnostic algorithm correlated with that of the pathologist.

[0128] This algorithm was also used prospectively in a preferred embodiment to classify the artery samples of the second validation data set into one of the three diagnostic classes as illustrated in FIG. 26B. Prospectively, the algorithm result agreed with that of the pathologist for 64 of 68 (94%). Comparison of the pathologic and Raman spectroscopic diagnoses for both data sets is shown in Table 2.

TABLE 2

Comparison of Pathologic Diagnosis with the of the Morphology-based Raman Diagnostic Algorithm				
Raman diagnosis Pathology diagnosis	I	II	III	Total
<u>Calibration data set</u>				
I	72	0	1	73
II	0	9	0	9
III	1	0	14	15
Total	73	9	15	97
<u>Prospective data set</u>				
I	26	0	0	26
II	0	12	4	16
III	0	0	26	26
Total	26	12	30	68

[0129] The classes are (I) nonatherosclerotic tissue, (II) noncalcified plaque, and (III) calcified plaque.

[0130] Because the in-vitro Raman system used for collecting macroscopic artery spectra is shot-noise limited, the NIR techniques used in acquiring the data have resulted in extremely high SNR spectra. The average peak-to-peak noise is less than 0.04 counts on normalized spectra. Calculation of error on the fit-coefficients of diagnostic morphologic components yield a three standard deviation (SD) error of 0.041 for CM, and a three-SD error of 0.036 for  $FC/NC_{NCR}+CC_{NCR}$ .

[0131] In another preferred embodiment, thirty-five coronary artery samples were taken from 16 explanted transplant recipient hearts, and thin sections were prepared. Using a high-resolution confocal Raman microspectrometer system with an 830-nm laser light, high signal-to-noise Raman spectra were obtained from the following morphologic structures: internal and external elastic lamina, collagen fibers, fat, foam cells, smooth muscle cells, necrotic core,  $\beta$ -carotene, cholesterol crystals, and calcium mineralizations. Their Raman spectra can be modeled by using a linear combination of basis Raman spectra from the major biochemicals present in arterial tissue, including collagen, elastin, actin, myosin, tropomyosin, cholesterol monohydrate, cholesterol linoleate, phosphatidyl choline, triolein, calcium hydroxyapatite, calcium carbonate, and  $\beta$ -carotene.

[0132] The results show that the various morphologic structures have characteristic Raman spectra, which vary little from structure to structure and from artery to artery. The biochemical model describes the spectrum of each morphologic structure well, indicating that the most essential biochemical components are included in the reference data. Furthermore, the biochemical composition of each structure, indicated by the fit contributions of the biochemical basis spectra of the morphologic structure spectrum, are very consistent. Thus, the Raman spectra of various morphologic structures in normal and atherosclerotic coronary artery may be used as basis spectra in a linear combination model to analyze the morphologic composition of atherosclerotic coronary artery lesions.

[0133] Raman spectroscopy has great potential for biochemical analysis of tissue on both the macroscopic and microscopic scale. One of the great advantages of this method is its ability to provide information about the concentration, structure, and interaction of biochemical molecules in their microenvironments within intact cells and tissues (i.e. in-situ), nondestructively, without homogenization, extraction, or the use of dyes, labels, or other contrast-enhancing agents. In addition, Raman spectroscopy can be performed in-vivo using optical fiber technology as described hereinbefore.

[0134] Using the predicate that morphologic factors may be as important as biochemical composition in determining plaque stability and progression, a preferred embodiment of the present invention includes the morphology-based diagnosis of atherosclerotic lesions in arterial tissue using Raman spectroscopy. To that end, in-situ Raman spectra of individual cellular and extracellular components of normal and atherosclerotic human coronary artery tissue were obtained in-vitro using confocal Raman microspectroscopy described hereinbefore. The biochemical composition of these microscopic morphologic structures were then deter-

mined by modeling their Raman spectra using a linear combination of basis Raman spectra of biochemicals in a similar way as used previously for intact tissue. Analogous to the macroscopic Raman spectroscopy biochemical analyses, these macroscopic Raman spectroscopy morphologic analyses can ultimately be used in a diagnostic algorithm to assess atherosclerotic plaque stability and disease progression in-vivo. Human coronary artery samples (n=35), exhibiting varying stages of atherosclerosis, were obtained from explanted recipient hearts (n=16) within 1 hour of heart transplantation. Immediately after dissection from the explanted hearts, the artery samples were rinsed with neutral buffered saline, snap frozen in liquid nitrogen, and stored at  $-85^{\circ}\text{C}$ .

[0135] Frozen coronary artery samples were mounted on a cryostat chuck with Histoprep (Fisher Diagnostics, Orangeburg, N.Y.). Thin transverse tissue sections (6-8  $\mu\text{m}$ ) for light microscopy and Raman microspectroscopy were cut using a cryostat/microtome (International Equipment, Needham Heights, Mass.). Four sections of each sample were mounted on glass microscope slides and stained with hematoxylin and eosin. Serial unstained sections were then mounted on  $\text{BaF}_2$  or  $\text{MgF}_2$  flats (International Scientific Products, Tarrytown, N.Y., and Spectra-Tech., Stamford, Conn.), kept moist with phosphate buffered saline (pH 7.4), and transferred to the microscope stage for spectroscopic experiments performed at room temperature. No coverslip was used for spectroscopic measurements. If spectra were collected from a large number of morphologic structures, each section was replaced by a freshly cut section after approximately 2 hours to avoid biochemical changes in the tissue as a result of enzymatic degradation. No significant changes were seen in the Raman spectra within this 2 hour period of study. The morphologic structures examined were in normal arteries: collagen fibers in the various layers of the arterial wall, internal and external elastic laminae, medial smooth muscle cells, and adventitial fat cells, and in intimal atherosclerotic lesions: collagen fibers in the fibrous cap, foam cells, necrotic core, cholesterol crystals,  $\beta$ -carotene-containing crystals, and calcium mineralizations.

[0136] A schematic representation of the system in accordance with the preferred embodiment of the present invention is shown in FIG. 27. All Raman spectroscopic measurements are carried out using a confocal configuration in order to suppress signal Raman light from features that are in peripheral surfaces other than the region of interest of the selected morphologic structure. The observation and analysis used a microscope (Zeiss Axioskop 50, Zeiss, Thornwood N.Y.), fitted with a phase contrast system and a stage controller (Prior Scientific Instruments, Cambridge, Mass.). Initial examination of the sample was performed with phase contrast microscopy at 10 $\times$  magnification (Zeiss Achromplan objective). Detailed examination and microspectroscopy were performed with 63 $\times$  infinitely corrected water immersion objective (Zeiss Achromplan, NA 0.9). The phase contrast tissue examination and morphologic structure selection for microspectroscopy were recorded using a CCD color video camera 758 (Sony, Cambridge, Mass.) attached to the microscope 750 and stored on video tape (VCR) 764 from which frames were digitized (PCVision-plus, Imaging Technologies, Bedford, Mass.).

[0137] Near-infrared (830 nm) laser light was generated by an  $\text{Ar}^+$  laser 742-pumped Ti: sapphire laser system 744

(Coherent Innova 90/Spectra Physics 3900S, Coherent, Santa Clara, Calif.). The laser output was band pass filtered **746** (F1) (Kaiser Optical Systems HLB, Ann Arbor, Mich.) and focused onto the sample using an adjustable mirror (m1) **748**, and a dichroic beamsplitter (m2) **754**, with a laser power on the sample **756** of 50-100 mW. Light emitted from the tissue sample was collected by the same objective, passed through the beamsplitter and passed through a pin-hole (P: 100  $\mu\text{m}$  diameter) by a removable mirror (m3) **752**. This mirror was used to direct either light emitted from the sample to the spectrometer/CCD system, or white light images to the video camera system. The light directed to the CCD/spectrometer is then Notch-filtered to reject Rayleigh scattered light (F2; Kaiser Optical Systems HSNF) and focused with an achromatic lens (L) into a Chromex 250IS/SM spectrograph-monochromator (Chromex, Albuquerque, N. Mex.). The spectrograph **766** includes a grating dispersed light onto a back illuminated deep-depletion CCD detector **768** (Princeton Instruments, Princeton, N.J.) cooled to  $-100^\circ\text{C}$ . The CCD interface (ST130 Princeton Instruments) was connected to a personal computer **774** using Winspec software (Princeton Instruments, version 1.4.3), which performed data processing and storage. At least three Raman spectra (sampling time between 10 and 100 s) over a range of 100-2000  $\text{cm}^{-1}$  (8  $\text{cm}^{-1}$  resolution) were obtained from each site selected.

**[0138]** The method to estimate the light collection or sampling volume of the confocal Raman microspectrometer uses a small (1-2  $\mu\text{m}^3$ ) collection volume to insure adequate resolution to collect Raman spectra from small or thin microscopic structures, such as individual collagen fibers. In short, polystyrene beads of 1.0  $\mu\text{m}$  diameter (Polysciences, Warrington, Pa.) were moved through the focused laser beam, and the Raman signal was collected as a function of the bead position relative to the center of the laser focus. The step resolution of the microscope stage in the horizontal plane was 1  $\mu\text{m}$ . Vertical displacement proceeded in 1.1  $\mu\text{m}$  steps. The position is optimized to obtain the maximal Raman signal of the bead. Lateral resolution is determined by alternately measuring the Raman signal of the central position and one of eight positions in the X or Y direction from the center of the bead using 1- or 2- $\mu\text{m}$  steps. The intensity of the strong 1004  $\text{cm}^{-1}$  polystyrene Raman band is measured as a function of the distance to the laser focus in both the planar directions and the axial direction. The result for each direction is then fitted with a Gaussian function, and the diameter of the focused beam is determined from the full width at half-maximum intensity (FWHM). For both lateral directions, the diameter is about 1  $\mu\text{m}$  while the axial direction is 2  $\mu\text{m}$ . The sampling volume is calculated to be about 2  $\mu\text{m}^3$ .

**[0139]** Data analysis of Raman spectra from morphologic structures is performed with Microcal Origin software (version 4.10, Clecom, Birmingham, UK). This analysis consists of cosmic ray removal, wavenumber shift calibration using the spectral features of toluene (Mallinckrodt Specialty Chemicals, Paris, Ky.) and correction for chromatic variation in the filter/spectrometer/CCD detector system with a calibrated tungsten light source. The tissue spectra is then corrected for  $\text{BaF}_2$  or  $\text{MgF}_2$  background contribution by subtraction of the appropriate spectrum, and corrected for tissue fluorescence by subtraction of a fourth-order polynomial that is fitted to the spectrum by least-squares minimization (LSM).

**[0140]** Each morphologic structure spectrum is modeled in the Raman shift range of 700-1800  $\text{cm}^{-1}$ , using a simple linear combination reference to generate fractional fit contributions ( $C_1$ ) for each of the 12 biochemical components, as

$$r_{\text{total}}=C_1r_1+C_2r_2+C_3r_3 \quad (4)$$

**[0141]** where  $r$  is the Raman spectrum. The 700-1800  $\text{cm}^{-1}$  Raman shift range is chosen because this range contains most spectral information.

**[0142]** Reagent grade commercial chemicals (Sigma, St. Louis, Mo.), are used to obtain the Raman spectra, for use as basis spectra, of the 12 biochemical components, including proteins (collagen type III, elastin, actin, myosin, and tropomyosin), unesterified cholesterol (cholesterol monohydrate), cholesterol esters (cholesterol linoleate), phospholipids (phosphatidyl choline), triglycerides (triolein), carotenoids ( $\beta$ -carotene), and calcium salts (calcium hydroxyapatite and calcium carbonate). These 12 biochemical components are selected as the most common Raman active biochemical species found in normal arterial tissue and atherosclerotic plaque. Additionally, a similar set of biochemical constituents has provided good fit of the reference data to the observed spectrum in previous macroscopic tissue studies. The Raman spectra from these chemicals is recorded in a similar way as the Raman spectra from the morphologic structures.

**[0143]** The reference data components cannot be scaled on chemical weight, since the actual concentration of the biochemicals in the various morphologic structures is unknown. Therefore, the intensity of the spectral feature at 1440-1455  $\text{cm}^{-1}$  (representing the bonding of  $\text{CH}_2$  bonds in protein and lipid) is set to unity. The Raman spectra of  $\beta$ -carotene, calcium carbonate, and calcium hydroxyapatite, which lack spectral features in this region, are set to unity with respect to spectral features at 1159, 1080, and 961  $\text{cm}^{-1}$ , respectively. This reference thus provides information about the relative fit contribution of these chemical components to the Raman spectra of the various morphologic structures. The fit contribution of each biochemical component is expressed as a fraction of the maximum (i.e. 1).

**[0144]** **FIG. 28A** is a photomicrograph of an unstained coronary artery section showing the internal elastic lamina viewed under phase contrast. This structure is examined at a total of 54 sites in 21 coronary artery samples. In nine of these samples, were collected spectra from the external elastic lamina. In **FIG. 28B**, the Raman spectra of six different internal elastic laminae are shown. The bands at 1664 and 1264  $\text{cm}^{-1}$  are attributable to the amide I and III vibrations, respectively, of structural proteins such as elastin and collagen. The intense band at 1449  $\text{cm}^{-1}$  can be assigned to the  $\text{CH}_2$  and  $\text{CH}_3$  bending mode of proteins, while the 1004  $\text{cm}^{-1}$  band is due to phenylalanine. The bands at 1336 and 1104  $\text{cm}^{-1}$  are attributable to desmosine/isodesmosine, and are specific for elastin. The bands at 933 and 855  $\text{cm}^{-1}$  can be assigned to the C—C stretching mode of proline and are present in collagen. These results indicate that internal elastic lamina contains both elastin and collagen. Furthermore, on visual inspection, these spectra show very little variation from structure to structure, indicating that the biochemical composition of internal elastic lamina is very consistent within and between coronary artery samples. Spectra obtained from the external elastic lamina are identical to those obtained from the internal elastic lamina.

[0145] **FIG. 29A** is a phase contrast photomicrograph showing collagen fibers (length approximately  $10\ \mu\text{m}$ , diameter approximately  $2\ \mu\text{m}$ ) in the connective tissue of the tunica adventitia. In total, 17 collagen fibers in 10 samples were studied. **FIG. 29B** shows the Raman spectra from collagen fibers from three different artery samples. Again, on visual inspection, these spectra collected from the adventitia (a, b) show little variation from fiber to fiber within or among coronary artery samples, and are identical to those taken from collagen fibers in the fibrous cap (c) of intimal atherosclerotic lesions. These spectra are also very similar to those from the elastic laminae, except for the absence of desmosine and isodesmosine bands (specific for elastin). The collagen fiber spectra also contain a pronounced hydroxyproline contribution ( $855\ \text{cm}^{-1}$ ) specific for collagen.

[0146] **FIG. 30** shows four Raman spectra recorded from smooth muscle cells in the tunica media in normal and atherosclerotic coronary artery samples in accordance with a preferred embodiment of the present invention. In total, 32 spectra were recorded from 10 coronary artery samples. On visual inspection, no significant differences were observed between spectra taken from individual smooth muscle cells. The main spectral features in the smooth muscle cell spectra are similar to those observed in the elastic laminae and collagen fiber spectra, and are dominated by protein bands at  $1660$  and  $1268\ \text{cm}^{-1}$  (amide I and III vibrations, respectively),  $853$ ,  $940$ ,  $1034$ ,  $1336$  and  $1451\ \text{cm}^{-1}$  (C—C or C—H bending), and  $1004\ \text{cm}^{-1}$  (phenylalanine). The main differences between the protein-dominated smooth muscle cell, elastic laminae, and collagen fiber spectra are in intensity variations in the phenylalanine ( $1004\ \text{cm}^{-1}$ ), desmosine/isodesmosine ( $1336$  and  $1104\ \text{cm}^{-1}$ ) and amide III ( $1268\ \text{cm}^{-1}$ ) bands.

[0147] **FIG. 31** shows examples of Raman spectra collected from fat cells (adipocytes) in the tunica adventitia in accordance with a preferred embodiment of the present invention. In total, eight adipocytes were examined from six coronary artery samples. The spectra collected from the fat cells are very similar, and are dominated by an ester band ( $1747\ \text{cm}^{-1}$ ), an unsaturated carbon/carbon band (C=C;  $1654\ \text{cm}^{-1}$ ), and  $\text{CH}_2/\text{CH}_3$  bands ( $1440$  and  $1301\ \text{cm}^{-1}$ ), which, in combination, indicate triglycerides.

[0148] **FIG. 32A** is a phase contrast photomicrograph of foam cells in the intima of an atheromatous plaque. The individual lipid droplets in these cells can easily be identified. In total, 30 foam cells in eight coronary artery samples were studied. In **FIG. 32B**, the Raman spectra from three foam cells are shown (a-c). Although similar on visual inspection, these spectra show more variation among foam cells than the spectra of collagen fibers, the internal and external elastic laminae, and smooth muscle cells. More specifically, the foam cell spectra are distinctly different from the protein-dominated spectra of the elastic laminae, collagen fibers, and smooth muscle cells, particularly with regard to the numerous bands below  $1100\ \text{cm}^{-1}$ . The bands at  $702$ ,  $878$ ,  $923$ , and  $957\ \text{cm}^{-1}$  can be assigned to the steroid nucleus of both unesterified (free) cholesterol and cholesterol esters. The intense bands at  $1671$ ,  $1439$ ,  $1299$ , and  $1270\ \text{cm}^{-1}$  are due to C=C stretch and  $\text{CH}_2/\text{CH}_3$  bending modes. The presence of bands at  $1735$  and  $1026\ \text{cm}^{-1}$  (specific for cholesterol esters) and  $1058$  and  $1328\ \text{cm}^{-1}$  (specific for free cholesterol) indicates that these foam cells contain both

esterified and unesterified cholesterol. As discussed previously, the reduced  $\text{CF}_{\text{NCR}}$  in non-calcified plaques is indicative of decreased plaque stability. The bands at  $719\ \text{cm}^{-1}$  (symmetric choline stretch),  $762\ \text{cm}^{-1}$  (symmetric O—P—O stretch), and  $878\ \text{cm}^{-1}$  (asymmetric O—P—O stretch) indicate the presence of phospholipids, and those at  $1523$  and  $1160\ \text{cm}^{-1}$  the presence of  $\beta$ -carotenoids. However, the foam cell spectra lack the triglyceride bands at  $1747$ ,  $1654$ ,  $1440$ , and  $1301\ \text{cm}^{-1}$  seen in adventitial fat cells.

[0149] In total, 31 necrotic core regions in 16 coronary artery samples were studied. **FIG. 32B** also shows two examples of Raman spectra collected from necrotic core (d and e). Similar to the foam cell spectra, there is some variation from structure to structure within the necrotic core. However, the average spectra from foam cells and necrotic core are quite similar, indicating that the chemical contents of both morphologic structures are quite similar.

[0150] **FIG. 33** shows examples of Raman spectra taken from cholesterol crystals of different size in the necrotic core of atheromatous plaques. In total, cholesterol crystals in seven coronary artery samples were studied. The main spectral features of the cholesterol crystal spectra are at  $1668\ \text{cm}^{-1}$  (C=C stretch),  $1443$ ,  $1328$ , and  $1274\ \text{cm}^{-1}$  ( $\text{CH}_2$ ,  $\text{CH}_3$  bending), and  $1176$  and  $1085\ \text{cm}^{-1}$  (C—C stretch). The spectral features below  $1000\ \text{cm}^{-1}$  are attributed to steroids, indicating the presence of unesterified cholesterol. Slightly more variation was seen between the spectra from individual crystals, mainly due to band intensity variations, indicative of differences in the ratio of free to esterified cholesterol in the crystals themselves or in the tissue components surrounding the crystals.

[0151] In necrotic core regions, yellow crystals could be identified under phase contrast occasionally. **FIGS. 33 (d and e)** shows the Raman spectra of two such crystals from two different coronary artery samples. In total, seven of these crystals from three samples were studied. The main spectral features are bands at  $1523$  and  $1160\ \text{cm}^{-1}$  which are due to C—C and C=C stretches and indicative of  $\beta$ -carotene. Given the presence of bands at  $1449$  and  $956\ \text{cm}^{-1}$ , these yellow crystals also appear to contain some structural proteins and cholesterol esters.

[0152] **FIG. 34A** is a photomicrograph of an atherosclerotic plaque containing a calcification. In total, 15 calcium mineralizations in six coronary artery samples were studied. Raman spectra representing different stages of calcification in two atherosclerotic plaques are shown in **FIG. 34B**. The main features of these spectra are  $1071$  and  $959\ \text{cm}^{-1}$  bands attributed to  $\text{CO}_3^{2-}$  (symmetric)/ $\text{PO}_4^{3-}$  (asymmetric) and  $\text{PO}_4^{3-}$  (symmetric) stretches, indicative of calcium carbonate and calcium hydroxyapatite, respectively. Large calcium mineralizations (**FIGS. 34B, a and b**) show spectral features different from those of minute punctate calcium mineralizations in the necrotic core (**FIGS. 34B, c**). The main difference is the presence of additional features in the spectra of the punctate calcium mineralizations attributable to lipids and/or phospholipids ( $1433\ \text{cm}^{-1}$ ), most likely due to the surrounding necrotic core.

[0153] Using the basis spectra of pure chemicals as illustrated in **FIG. 35**, the spectra of the individual morphologic structures were fitted in the biochemical model. Each panel in **FIGS. 36A-H** shows a Raman spectrum of one of the morphologic structures, and the result of the least-squares

minimization fit of the biochemical model. Residuals (data minus the fit) are shown on the same scale. Because the Raman spectra from foam cells and necrotic core were very similar, only the fit results of the foam cells are shown. Judging from the residuals of the fits to the observed spectra, which are on the order of magnitude of the noise and show no consistent pattern from spectrum to spectrum, the Raman spectrum of each morphologic structure (panels A-H) is well described using the 12 biochemical basis spectra.

[0154] For each morphologic structure examined, the contribution of each biochemical component was determined. FIGS. 37A-H confirm that each morphologic structure has a characteristic biochemical composition. Generally, each morphologic structure is composed largely of one or two major biochemical components, combined with one or more less abundant biochemical components.

[0155] The internal and external elastic laminae (FIG. 37A) are mainly composed of elastin with a smaller collagen component, whereas collagen fibers in both normal arteries and the fibrous cap of atherosclerotic lesions (FIG. 37B) are mainly composed of collagen with a small elastin component. Smooth muscle cells (FIG. 37C) were modeled almost entirely by actin and a small tropomyosin component. Myosin did not contribute at all.

[0156] Adventitial fat cells (FIG. 37D) contain almost exclusively triglycerides (triolein) with a small contribution of phospholipids (phosphatidyl choline). In contrast, foam cells and necrotic core (FIG. 37E) contains mainly cholesterol esters (linoleate) and free cholesterol (monohydrate) at a ratio of about 2:1, with smaller contributions of collagen, phospholipids, and  $\beta$ -carotene. Foam cells appear similar in the current data and cannot be distinguished from necrotic core on the basis of their biochemical composition. However in a following assessment they can be distinguished. For example, the spectral feature at approximately  $1750\text{ cm}^{-1}$  can be used to distinguish the foam cells from the necrotic core. Cholesterol crystals (FIG. 37F) contain free cholesterol and cholesterol ester at a ratio of about 3:1. The yellow crystals (FIG. 37G) consist almost entirely of  $\beta$ -carotene, with a small contribution of cholesterol. This may indicate that these crystals are in fact cholesterol crystals that contain high concentrations of  $\beta$ -carotene. Calcium mineralizations (FIG. 37H) are mainly composed of calcium hydroxyapatite with small contributions of collagen, triglycerides, and calcium carbonate.

[0157] The presence of foam cells and other inflammatory cells may also play a role in plaque instability. Therefore, morphologic factors, such as the presence of crystalline-free cholesterol or foam cells, may be as important as biochemical composition in determining atherosclerotic plaque stability and progression.

[0158] As was shown in FIG. 36, the biochemical model of FIG. 35 describes the spectrum of each morphologic structure well, which means that the most essential biochemical components are included in the reference. The biochemical composition of each structure, indicated by the fit contributions of the biochemical basis spectra to the morphologic structure spectrum, is very consistent (FIGS. 36A-H). The largest biochemical variations were found in foam cells, necrotic core, cholesterol crystals, and calcium mineralizations. The biochemical variations in both calcium mineralizations, cholesterol crystals, and  $\beta$ -carotene-con-

taining crystals may be due to differences in their stage of progression (as reflected by size). The cause of the biochemical variations within foam cells and necrotic core (differences in collagen,  $\beta$ -carotene, and cholesterol esters) is less clear. Variations in the lipid composition of atherosclerotic plaques at various stages of progression have been described previously in in-vitro studies of homogenized or extracted tissues and cultured monocyte-derived foam cells. However, these biochemical data are the results of analysis of atherosclerotic plaque components in-situ, without the confounding effects of tissue preparation or in-vitro cell culture models. More detailed in-situ Raman microspectroscopy studies of foam cells and necrotic cores in atherosclerotic plaques at various stages of disease progression may help to further elucidate the origin of this variation.

[0159] Although the biochemical model did provide valuable information on the biochemical composition of the microscopic cellular and extracellular morphologic structures, it has its limitations. One of the major limitations of this model and/or reference was illustrated by the fits of the smooth muscle cell spectra. Previous in-vitro studies have shown that smooth muscle cells, which comprise the majority of the tunica media of muscular arteries such as the coronary artery, contain approximately three times more actin than myosin, but approximately equal amounts of myosin and tropomyosin. However, the fit contributions in the biochemical model indicated that smooth muscle cells contained almost exclusively actin, with a small amount of tropomyosin and virtually no myosin. These unexpected results may be due to conformational differences in spectroscopic characteristics of myosin between tissue-extracted myosin and intracellular myosin in-situ. In addition, as seen with the glycosaminoglycans, the contribution of weak Raman scatterers may be underestimated.

[0160] Observed variations may also be due to contributions of biochemical compounds that are not included in the reference. For example, only one class of collagen was included. This should not be a great concern, as there is little difference observed in the Raman spectra of the different classes of collagens in-vitro. However, there may be significant changes in the Raman spectra of collagen in-vivo due to increased crosslinking as atherosclerotic lesions progress.

[0161] Despite these limitations, the results of previous quantitative Raman spectroscopic biochemical analyses of normal and atherosclerotic arterial tissue, using the same biochemical model, compared well with standard analytical techniques. Previous studies have also shown that these quantitative Raman spectroscopy biochemical analyses could be used as the basis of a diagnostic algorithm that accurately classified arterial tissues as either nonatherosclerotic or calcified or noncalcified atherosclerotic plaque. The results of the preferred embodiments of the present invention indicate that a modification of the biochemical model can be used to perform a relative comparison of cellular and extra cellular morphologic components of normal and atherosclerotic arterial tissue. Furthermore, another preferred embodiment shows that these relative morphologic comparisons can be used as the basis for an algorithm that allows diagnosis of atherosclerosis in coronary arteries. This is the first step in developing a quantitative Raman spectroscopy morphologic analysis with the purpose to accurately classify

normal arteries and atherosclerotic plaques *ex vivo*, and in the future to predict plaque stability and disease progression *in-vivo*.

[0162] Using the biochemical model reference of the preferred embodiment, confocal Raman microspectroscopy is illustrated to be used to perform an *in-situ* biochemical analysis of individual microscopic morphologic structures (such as foam cells and necrotic core) in intact arterial tissues that cannot be isolated or purified using conventional analytical techniques. Furthermore, the various morphologic structures have characteristic Raman spectra, which, as expected, vary little from structure to structure or from artery to artery, and can be used as basis spectra in a morphologic reference to perform a relative comparison of the morphology of normal and atherosclerotic coronary arteries *ex-vivo*. This nondestructive technique may ultimately be used to assess plaque stability and disease progression in humans *in-vivo*, as well as to study atherogenesis in animal models and lipid metabolism in cell cultures *in-vitro*.

[0163] The embodiments of the present invention interpret Raman spectra in terms of morphology. For example, the Raman spectra can be associated with a morphological structure, for example, a foam cell which can be associated with specific chemical compounds. Further, the number of spectra can be reduced, for example, from a large number of chemical spectra to only eight unique spectra associated with morphological structures thereby decreasing the error in the fit. The diagnostics that are available to identify and monitor vulnerable plaque using the optical fiber catheter system of the present invention include the use of chemical composition, information about the morphological structures, thickening of the intimal layer and the thinning of the overlying collagen layer. Preferred embodiments include the determination of the depth of collagen by measuring the percentage of collagen. Further, the presence of calcification is monitored and any edges are identified and located relative to the collagen as indicators of a potential rupture and blood clot. As discussed previously, the reduced fractional fit contributions of collagen fibers in non-calcified plaques is an indicator of unstable plaque.

[0164] The claims should not be read as limited to the described order or elements unless stated to that effect. Therefore, all embodiments that come within the scope and spirit of the following claims and equivalents thereto are claimed as the invention.

What is claimed:

1. A probe for measuring tissue, comprising:

a fiber optic probe having a proximal end, a distal end, and a diameter of 2 mm or less;

a delivery optical fiber in the probe coupled at the proximal end to a light source and having a first filter at the distal end;

a collection optical fiber in the probe that collects Raman scattered radiation from tissue, the collection optical fiber being coupled at the proximal end to a detector and having a second filter at the distal end; and

an optical lens system at the distal end of the probe including a delivery waveguide coupled to the delivery

fiber, a collection waveguide coupled to the collection fiber and one of a reflective and refractive optical element.

2. The probe of claim 1 wherein the delivery waveguide comprises a rod and the collection waveguide comprises a cylindrical tube, the tube being concentric about the rod.

3. The probe of claim 1 wherein the lens comprises a ball lens optically coupled to the delivery fiber and the collection fiber.

4. The probe of claim 1 further comprising a sleeve that optically isolates the delivery waveguide from the collection waveguide.

5. The probe of claim 1 further comprising a first plurality of collection fibers arranged concentrically about the delivery fiber at a first radius, and a second plurality of collection fibers arranged concentrically about the delivery fiber at a second radius that is larger than the first radius.

6. The probe of claim 1 further comprising a controller that gates a collection time, the collection time being less than 2 seconds.

7. The probe of claim 1 wherein the optical lens system has a length less than 10 mm.

8. The probe of claim 1 wherein the optical lens system has a length of less than 4 mm.

9. The probe of claim 1 wherein the light source has a wavelength longer than 750 nm.

10. The probe of claim 1 wherein the optical lens systems delivers and collects radiation in a radial direction.

11. The probe of claim 1 wherein the probe measures spectral features of cardiac tissue.

12. A spectroscopic diagnostic system for measuring tissue comprising:

a fiber optic probe having a proximal end, a distal end;

a delivery optical fiber in the probe coupled at the proximal end to a light source to deliver radiation to the distal end, the delivery optical fiber having a first filter at the distal end;

a collection optical fiber in the probe that collects Raman scattered radiation from tissue, the collection optical fiber being coupled at the proximal end to a detector system, the collection optical fiber having a second filter at the distal end; and

an optical lens system at the distal end of the probe including a delivery waveguide coupled to the delivery optical fiber and a collection waveguide coupled to the collection optical fiber and lens system.

13. The spectroscopic diagnostic system of claim 12 wherein the delivery waveguide comprises a rod and the collection waveguide comprises a cylindrical tube, the tube being concentric about the rod.

14. The spectroscopic diagnostic system of claim 12 wherein the delivery waveguide comprises a first cylindrical tube and the collection waveguide comprises a second cylindrical tube, the second cylindrical tube being concentric about the first cylindrical tube.

15. The spectroscopic diagnostic system of claim 12 wherein the lens system comprises an elliptical axicon optically coupled to the delivery optical fiber and the collection optical fiber.

16. The spectroscopic diagnostic system of claim 12 further comprising a sleeve that optically isolates the delivery waveguide from the collection waveguide.

**17.** The spectroscopic diagnostic system of claim 12 further comprising a first plurality of collection fibers arranged concentrically about the delivery fiber at a first radius, and a second plurality of collection fibers arranged concentrically about the delivery fiber at a second radius that is larger than the first radius.

**18.** The spectroscopic diagnostic system of claim 12 wherein the spectroscopic diagnostic system generates a circumferential image.

**19.** The spectroscopic diagnostic system of claim 12 further comprising a controller that gates a collection time, the collection time being less than 2 seconds.

**20.** The spectroscopic diagnostic system of claim 12 wherein the optical lens system has a length less than 10 mm.

**21.** The spectroscopic diagnostic system of claim 12 wherein the optical lens system has a length of less than 4 mm.

**22.** The spectroscopic diagnostic system of claim 12 wherein the light source has a wavelength longer than 750 nm.

**23.** The spectroscopic diagnostic system of claim 12 wherein the optical lens systems delivers and collects radiation in a radial direction.

**24.** A spectroscopic catheter system for measuring system, comprising:

a fiber optic probe having a proximal end and a distal end;

at least one delivery optical fiber in the probe coupled at the proximal end to a light source and having a first filter at the distal end;

at least one collection optical fiber in the probe that collects Raman scattered radiation from tissue, the collection optical fiber being coupled at the proximal end to a detector and having a second filter at the distal end; and

an optical system at the distal end of the probe including a delivery waveguide coupled to the delivery optical fiber, a collection waveguide coupled to the collection optical fiber and one of a reflective and refractive optical element.

**25.** The spectroscopic catheter system of claim 24 further comprising an inflatable balloon disposed around the fiber optic probe.

**26.** The spectroscopic catheter system of claim 25 further comprising a channel for inflating the balloon.

**27.** The spectroscopic catheter system of claim 24 wherein the delivery waveguide comprises a rod and the collection waveguide comprises a cylindrical tube, the tube being concentric about the rod.

**28.** The spectroscopic catheter system of claim 24 wherein the delivery waveguide comprises a first cylindrical tube and the collection waveguide comprises a second cylindrical tube, the second cylindrical tube being concentric about the first cylindrical tube.

**29.** The spectroscopic catheter system of claim 24 wherein the optical element comprises an elliptical axicon optically coupled to the delivery optical fiber and the collection optical fiber.

**30.** The spectroscopic catheter system of claim 24 further comprising a sleeve that optically isolates the delivery waveguide from the collection waveguide.

**31.** The spectroscopic catheter system of claim 24 further comprising a first plurality of collection fibers arranged concentrically about the delivery fiber at a first radius, and a second plurality of collection fibers arranged concentrically about the delivery fiber at a second radius that is larger than the first radius.

**32.** The spectroscopic catheter system of claim 24 wherein the spectroscopic catheter system generates a circumferential image.

**33.** The spectroscopic catheter system of claim 24 wherein the optical element comprises a ball lens optically coupled to the delivery optical fiber and the collection optical fiber.

**34.** The spectroscopic catheter system of claim 24 further comprising a controller that gates a collection time, the collection time being less than 2 seconds.

\* \* \* \* \*

专利名称(译)	用于生物组织的光谱学的系统和方法		
公开(公告)号	<a href="#">US20030191398A1</a>	公开(公告)日	2003-10-09
申请号	US10/178062	申请日	2002-06-21
[标]申请(专利权)人(译)	麻省理工学院		
申请(专利权)人(译)	麻省理工学院		
当前申请(专利权)人(译)	麻省理工学院		
[标]发明人	MOTZ JASON T GALINDO LUIS H HUNTER MARTIN DASARI RAMACHANDRA FELD MICHAEL S		
发明人	MOTZ, JASON T. GALINDO, LUIS H. HUNTER, MARTIN DASARI, RAMACHANDRA FELD, MICHAEL S.		
IPC分类号	A61B1/00 A61B5/00 G01N21/47 G01N21/65 A61B6/00		
CPC分类号	A61B5/0071 A61B5/0075 A61B5/0084 A61B5/0086 A61B5/0091 G01N2021/656 A61B5/4519 G01N21/474 G01N21/65 G01N2021/4745 G01N2021/4759 A61B5/415 A61B5/02007 A61B5/4312 A61B5/7232		
优先权	60/370197 2002-04-05 US		
其他公开文献	US7647092		
外部链接	<a href="#">Espacenet</a> <a href="#">USPTO</a>		

摘要(译)

本发明的系统和方法涉及使用光谱学，例如，拉曼光谱法，用于诊断组织病症，例如血管疾病或癌症。根据本发明的优选实施例，一种用于测量组织的系统包括光纤探针，该光纤探针具有近端，远端和2mm或更小的直径。这种小直径允许该系统用于诊断冠状动脉疾病或其他小腔或软组织，创伤最小。传输光纤包括在探头中，该探头在近端耦合到光源。用于输送纤维的过滤器包括在远端。该系统包括探头中的收集光纤（或光纤），其收集来自组织的拉曼散射辐射，收集光纤在近端处耦合到检测器。第二过滤器设置在收集纤维的远端。光学透镜系统设置在探头的远端，包括耦合到传输光纤的传输波导，耦合到收集光纤的收集波导和透镜。

