



US 20030009114A1

(19) **United States**

(12) **Patent Application Publication** (10) **Pub. No.: US 2003/0009114 A1**

Chin et al.

(43) **Pub. Date:**

Jan. 9, 2003

(54) **MEDICAL DEVICE WITH EXTRUDED MEMBER HAVING HELICAL ORIENTATION**

(22) Filed: **Jul. 3, 2001**

(75) Inventors: **Albert Chin**, Newton, MA (US); **John Chen**, Plymouth, MN (US); **Lixiao Wang**, Long Lake, MN (US); **Ronald Sahatjian**, Lexington, MA (US); **Yiqun Wang**, Maple Grove, MN (US)

Publication Classification

(51) **Int. Cl.⁷** **A61B 5/00; D01D 5/20**

(52) **U.S. Cl.** **600/585; 604/264; 264/167**

Correspondence Address:

Robert E. Atkinson
CROMPTON, SEAGER & TUGTE, LLC
Suite 895
331 Second Avenue South
Minneapolis, MN 55401-2246 (US)

(57) **ABSTRACT**

An elongate polymer member having molecular helical orientation formed by rotation immediately after passing through the extrusion head. The elongate polymer member is rotated downstream of the extrusion head in the molten state prior to solidification in order to impart the molecular helical orientation. Rotating the polymer member in the molten state allows the helical orientation to be imparted at the molecular level, and allows for more rotations per lineal foot of extrusion.

(73) Assignee: **SciMed Life Systems, Inc.**

(21) Appl. No.: **09/898,710**

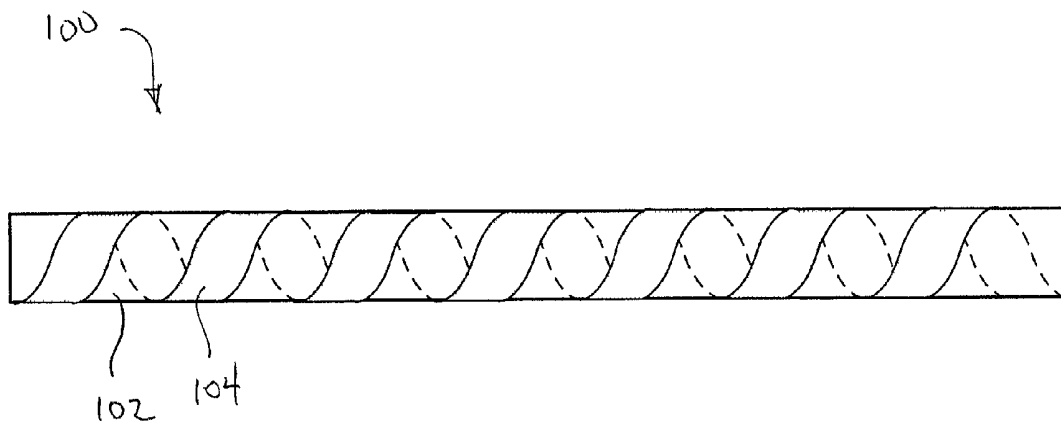

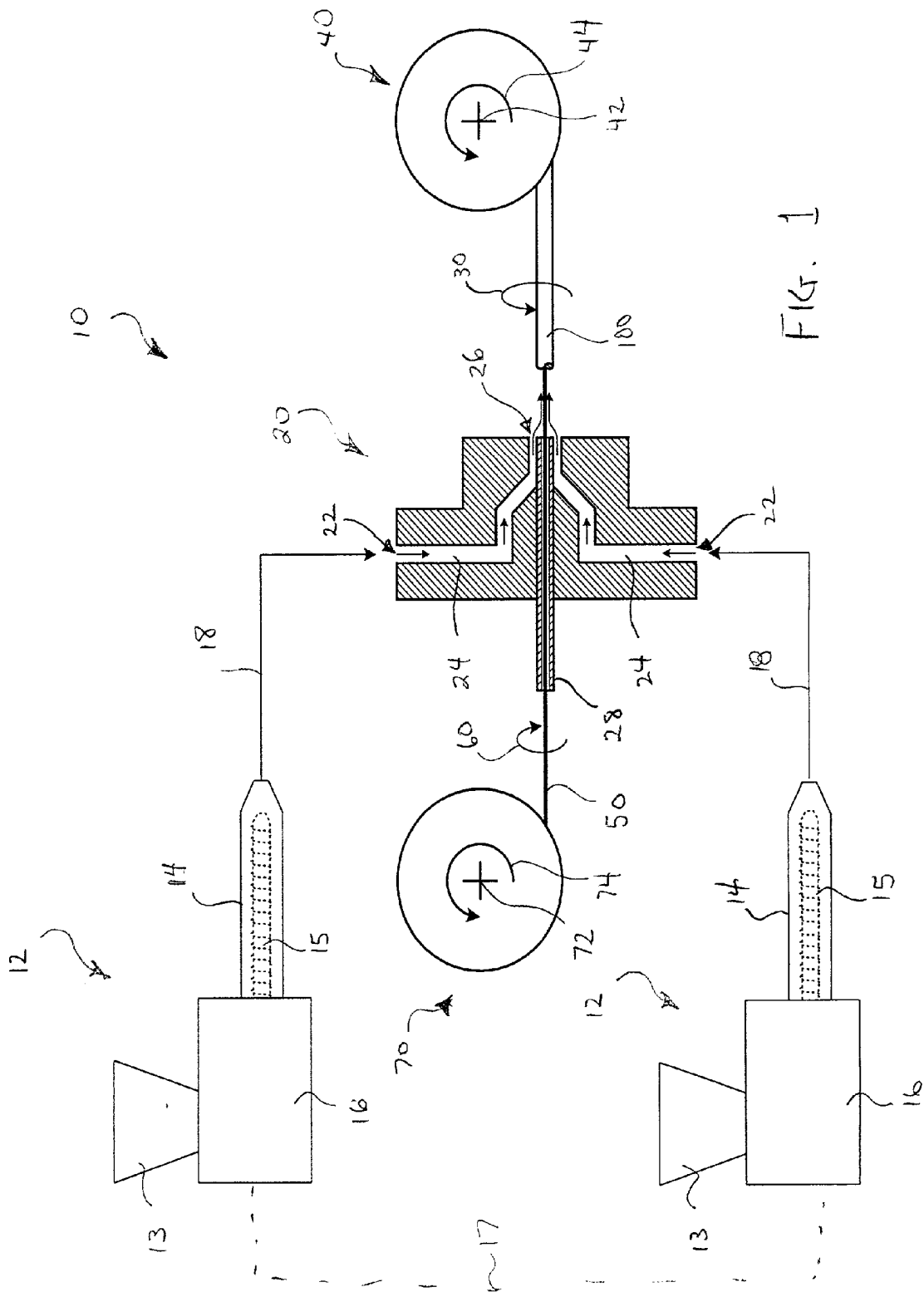

FIG. 1

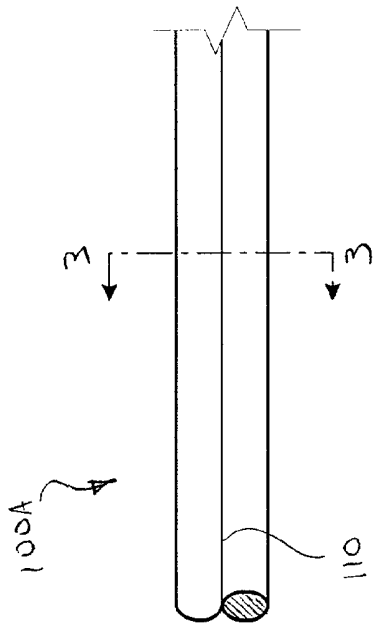

FIG. 2

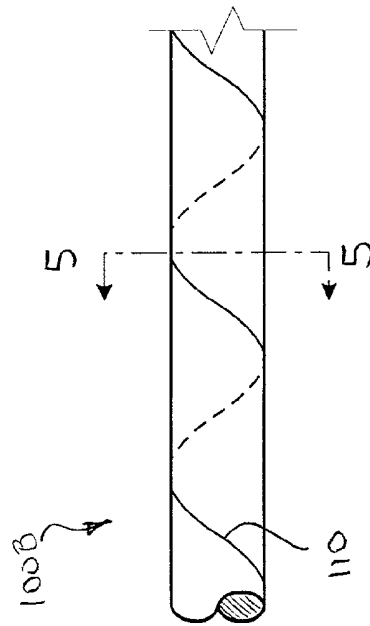

FIG. 4

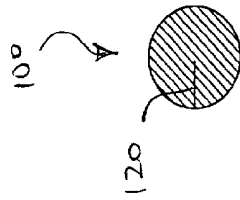

FIG. 3A

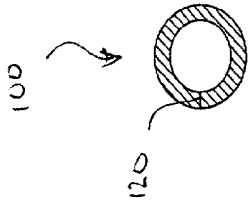

FIG. 3B

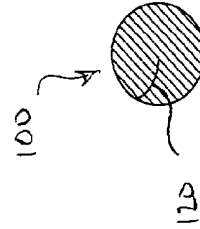

FIG. 5A

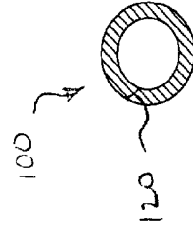
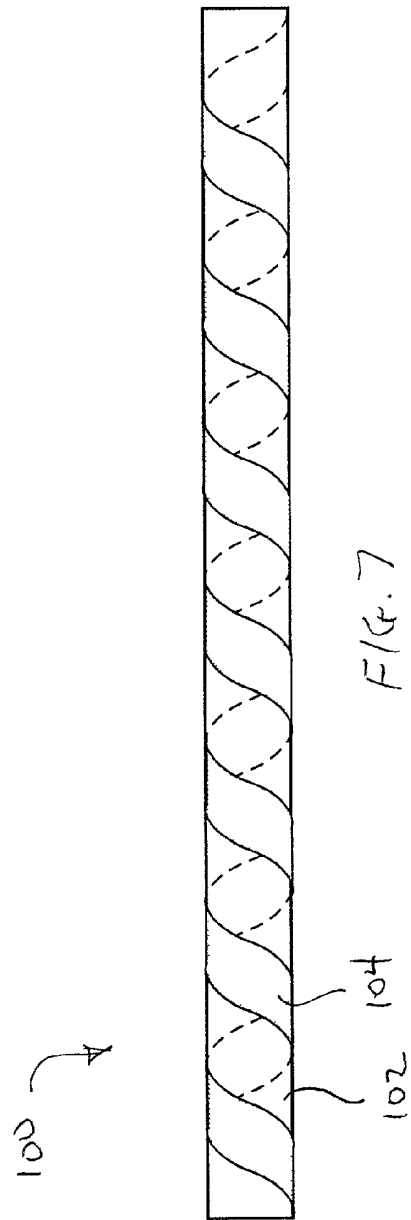
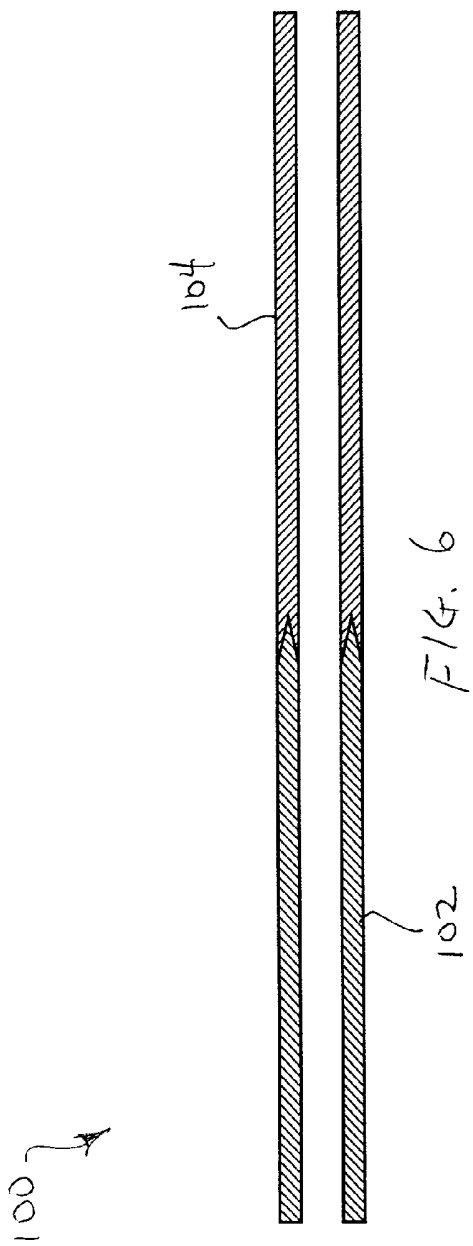
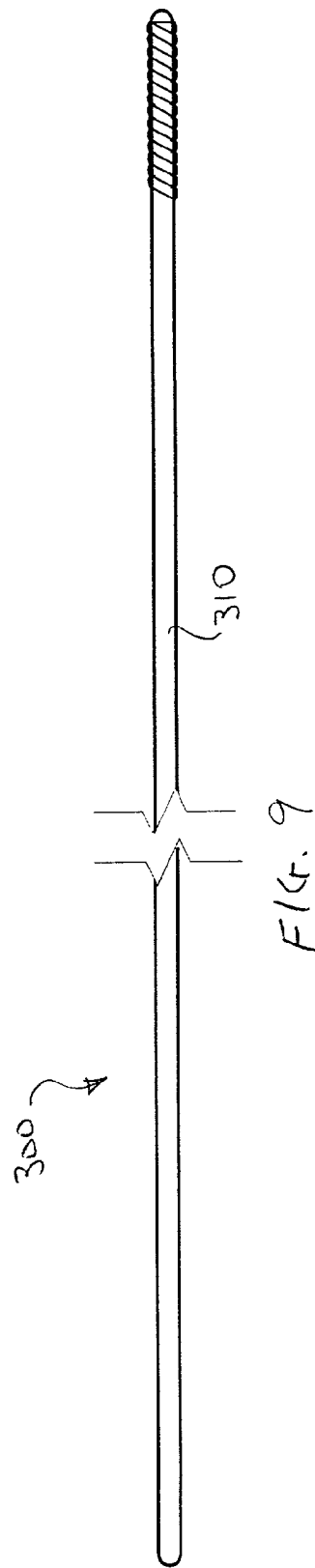
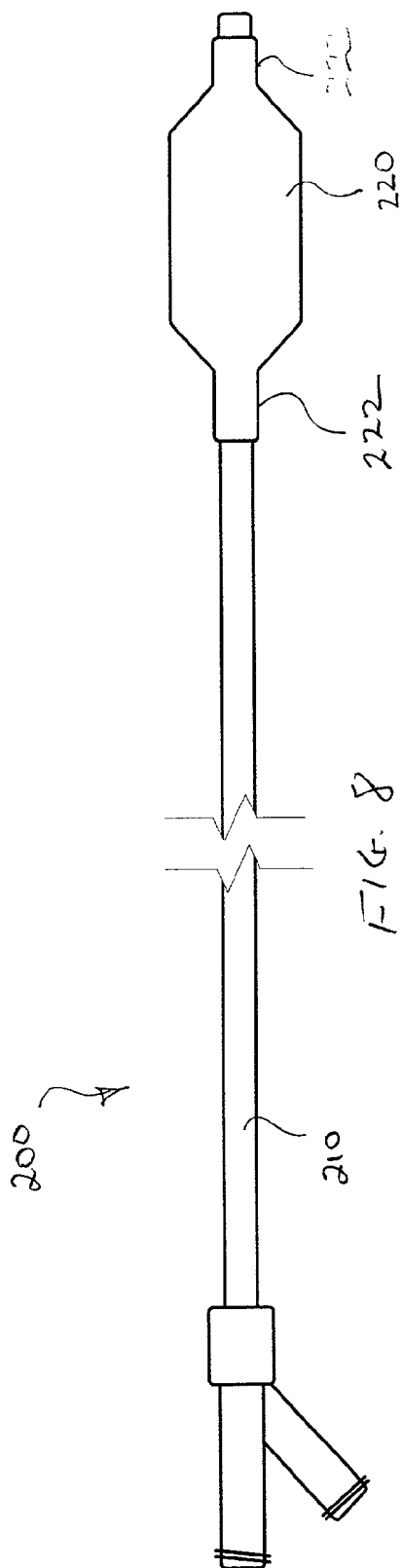

FIG. 5B





MEDICAL DEVICE WITH EXTRUDED MEMBER HAVING HELICAL ORIENTATION

FIELD OF THE INVENTION

[0001] The present invention generally relates to medical devices having extruded polymeric members. More specifically, the present invention relates to medical devices such as intravascular catheters and guide wires having extruded polymeric members with helical orientation.

BACKGROUND OF THE INVENTION

[0002] A wide variety of medical devices utilize extruded polymeric members. For example, intravascular catheters and guide wires commonly utilize an extruded polymeric member as a shaft component. Because intravascular catheters and guide wires must exhibit good torqueability, trackability and pushability, it is desirable that the extruded polymeric shaft component have good torque transmission, flexibility and column strength. These attributes are commonly incorporated into intravascular devices by utilizing a composite shaft construction. Alternatively, the polymer material which forms the shaft component may be oriented to enhance the mechanical characteristics thereof.

[0003] For example, U.S. Pat. No. 5,951,494 to Wang et al. discloses a variety of medical instruments, such as guide wires and catheters, formed at least in part of elongated polymer members having helical orientation. The helical orientation is established by processing an elongate polymer member with tension, heat and twisting. Wang et al. theorize that the tension, heat and twisting process results in a polymer member that has helical orientation on the molecular level. Such molecular helical orientation enhances torque transmission of the elongate polymer member, which is important for some types of intravascular medical devices that must be navigated through long and tortuous vascular pathways.

[0004] Wang et al. teach that the tension, heat and twisting is a post-processing technique performed on a preformed polymer member. The pre-formed polymer member may comprise, for example, a rod, a tube, a polymer-metal composite, or a polymer/non-metal composite. Because Wang et al. teach post-processing of a pre-formed polymer member, the resulting oriented polymer member inherently involves two (or more) separate processes. First, the polymer member must be formed by, for example, an extrusion process, and second, the polymer member must be oriented by post-processing (i.e., tension, heat and twisting).

[0005] Because these two separate processes may involve manufacturing inefficiencies, it is desirable to provide a single manufacturing process to form an elongate polymer member having helical molecular orientation. For example, it may be desirable to provide an extrusion process to obtain a polymer member with molecular helical orientation. However, to our present knowledge, such an extrusion process is not known in the prior art. Perhaps the closest examples of related extrusion processes are disclosed in U.S. Pat. No. 5,059,375 to Lindsay and U.S. Pat. No. 5,639,409 to Van Muiden.

[0006] Lindsay '375 discloses an extrusion process for producing flexible kink resistant tubing having one or more spirally-reinforced sections. The extruder includes a rotat-

able head having an extrusion passageway for spirally extruding a thermoplastic filament into a base thermoplastic material to form a spirally-reinforced tube. The rotatable head is rotated at a predetermined velocity to form the reinforcement filament in a spiral or helical pattern in the wall of the tubing. However, with this process, the wall of the tubing is not helically oriented at all, and neither the filament nor the wall of the tubing are helically oriented on the molecular level. Accordingly, the resulting tubing does not enjoy the advantages obtained by molecular helical orientation as disclosed in Wang et al.

[0007] Van Muiden '409 discloses an extrusion process for manufacturing a tube-like extrusion profile by conveying a number of divided streams of different polymeric materials to a rotating molding nozzle. The streams of material flow together in the rotating molding nozzle to form at least two helically shaped bands of material. After allowing the combined streams of material to cool off, an extrusion profile comprising a plurality of bands of polymeric material extending in a helical pattern is formed. However, the bands of material are not helically oriented on the molecular level as in Wang et al. since the helical pattern is imparted by the rotating nozzle when the polymeric materials are in a molten state.

[0008] From the foregoing, those skilled in the art will appreciate that there exists an unmet need for a single manufacturing process to form an elongate polymeric member having molecular helical orientation.

SUMMARY OF THE INVENTION

[0009] To address this unmet need, the present invention provides an elongate polymer member having molecular helical orientation formed by rotation immediately after passing through the extrusion head. In particular, the elongate polymer member is rotated downstream of the extrusion head in the molten state prior to solidification in order to impart the molecular helical orientation. The molten state refers to a state in which the polymer is below the melting temperature but above the glass transition temperature. Rotating the polymer member in the molten state allows the helical orientation to be imparted at the molecular level. In addition, rotating the polymer member in the molten state allows for more rotations per lineal foot than otherwise feasible with post-processing techniques.

[0010] The polymer member may be rotated at speeds of 1000 rpm or more, and preferably at 3,500 rpm or more. The extrusion rate may range from 10 fpm to 100 fpm, and preferably 20 fpm to 50 fpm. The resulting helical orientation ranges from 10 rotations per foot (rpf) to 350 rpf, and preferably ranges from 70 rpf to 175 rpf. The extrusion rate and/or the rotation rate may be varied during the extrusion process to vary the degree of molecular orientation at various positions along the elongate member.

[0011] The elongate polymer member may comprise a single polymer extrusion, a multi-polymer intermittent co-extrusion, or a multi-polymer continuous co-extrusion. The elongate polymer member may comprise a single layer, multiple layers, or a composite. The elongate polymer member may be extruded over a core member which may carry a substrate (e.g., PTFE tube, wire braid, wire coil, etc.) onto which the elongate polymer member is extruded. The core member may be removed after extrusion to form a

tubular structure. The elongate polymer member may be fed back into the extrusion system for a second pass to create an outer layer preferably having a molecular helical orientation in the opposite direction from that of the first pass.

BRIEF DESCRIPTION OF THE DRAWINGS

[0012] FIG. 1 is a schematic illustration of an extrusion system in accordance with an embodiment of the present invention, showing the extrusion head in cross section;

[0013] FIG. 2 schematically illustrates an elongate polymer member without helical orientation;

[0014] FIG. 3A is a cross-sectional view taken along line 3-3 in FIG. 2 showing a solid polymer member;

[0015] FIG. 3B is a cross-sectional view taken along line 3-3 in FIG. 2 showing a tubular polymer member;

[0016] FIG. 4 schematically illustrates an elongate polymer member with molecular helical orientation;

[0017] FIG. 5A is a cross-sectional view taken along line 5-5 in FIG. 4 showing a solid polymer member;

[0018] FIG. 5B is a cross-sectional view taken along line 5-5 in FIG. 4 showing a tubular polymer member;

[0019] FIG. 6 schematically illustrates a longitudinal sectional view of an elongate polymer member having molecular helical orientation formed by intermittent co-extrusion;

[0020] FIG. 7 schematically illustrates an elongate polymer member having molecular helical orientation formed by continuous co-extrusion;

[0021] FIG. 8 illustrates an intravascular balloon catheter incorporating an extruded polymeric member having molecular helical orientation in accordance with the present invention; and

[0022] FIG. 9 illustrates an intravascular guide wire incorporating an extruded polymeric member having molecular helical orientation in accordance with the present invention.

DETAILED DESCRIPTION OF THE INVENTION

[0023] The following detailed description should be read with reference to the drawings in which similar elements in different drawings are numbered the same. The drawings, which are not necessarily to scale, depict illustrative embodiments and are not intended to limit the scope of the invention.

[0024] Refer now to FIG. 1 which illustrates an extrusion system 10 in accordance with the present invention. Extrusion system 10 includes one or more extruders 12 coupled to a non-rotatable extrusion head 20 as schematically illustrated by extrusion lines 18. Each extruder 12 includes a hopper 13, a heated barrel 14, an extrusion screw 15, and a control system 16, which may be coupled to other control systems of other extruders as indicated by dashed line 17 to facilitate co-extrusion.

[0025] Molten polymer enters the extrusion head 20 at inlets 22. The molten polymer flows through the extrusion passages 24 as indicated by the small arrows. The molten polymer exits the extrusion head 20 through outlet 26. Upon exiting the extrusion head 20 through outlet 26, the

molten polymer begins to solidify thereby creating a molten polymer state. In the molten state, the polymer typically has a temperature below the melting point but at or above the glass transition point.

[0026] In this molten state, the elongate polymer member is rotated as indicated by arrow 30. The elongate polymer member 100 may be rotated manually or automatically by a suitable rotational drive mechanism. The direction of rotation 30 may be clockwise or counter clockwise as desired. By rotating the polymer member 100 in the molten state, a molecular helical orientation is imparted thereto. In particular, in the molten state, the crystalline regions of the polymer are helically oriented by rotation and subsequently allowed to cool to thereby lock-in the helical orientation. The molecular helical orientation imparted to the polymer member 100 is similar to the helical orientation imparted by the process disclosed in U.S. Pat. No. 5,951,494 to Wang et al., the entire disclosure of which is hereby incorporated by reference.

[0027] The elongate polymer member 100 may be cut into discrete lengths immediately after extrusion or spooled onto spool 40. Spool 40 rotates in a direction indicated by arrow 44 about an axis at the intersection of lines 42. If the elongate polymer member 100 is taken up by spool 40, the elongate polymer 100 and the spool 40 may be rotated simultaneously.

[0028] The elongate polymer member 100 may be formed by a single polymer or by multiple polymers by co-extrusion. For purposes of illustration only, the extrusion system 10 is shown as a two polymer co-extrusion system. Those skilled in the art will recognize that the extrusion head 20 and the number of extruders 12 may be modified depending on the number of polymers incorporated into the elongate polymer member 100.

[0029] The elongate polymer 100 may have a solid cross section or a tubular cross section. In addition, the elongate polymer member 100 may be extruded over a core member 50 which may be left in the elongate polymer member 100 or subsequently removed. The core member 50 is fed into the extrusion at 20 by guide tube 28. The core member 50 may comprise a metal wire or may comprise a composite substrate disposed on a metal wire. Examples of composite substrates include wire braid, wire coils, polymer braids, polymer coils, lubricious tubular members such as PTFE, etc. Subsequent to extrusion, the core member 50 may be removed to form a tubular elongate polymer member 100, with the substrate (if any) previously disposed on the core member 50 imbedded into the inside surface of the tubular elongate member 100.

[0030] If a core member 50 is used, the core member 50 is preferably rotated as indicated by arrow 60. Also preferably, the direction of rotation 60 of the core member 50 is the same as the direction of rotation 30 of the elongate polymer member 100. The core member 50 may be rotated manually or automatically by a suitable drive mechanism. The core member 50 may be disposed on spool 70 which rotates in the direction indicated by arrow 74 about an axis at the intersection of lines 72. If the core member 50 is provided on a spool 70, it may be necessary to rotate the spool 70 along with the core member 50 as indicated by arrow 60.

[0031] As an alternative, the core member 50 may comprise a previously formed polymer member 100 having

helical orientation. In particular, the elongate polymer member **100** may be fed back into the extrusion system as a core member **50** for a second pass. The second pass creates an outer polymeric layer having a molecular helical orientation. Preferably, in the second pass, the elongate polymer member **100** and outer layer are rotated in the opposite direction from that of the first pass to provide helical orientation in different directions.

[0032] Refer now to **FIGS. 2 and 4** which provide a schematic comparison between an elongate polymer member **100A** without molecular helical orientation as shown in **FIG. 2** and an elongate polymer member **100B** with molecular helical orientation as shown in **FIG. 4**. The elongate polymer members **100A/100B** are illustrated with longitudinal reference lines **110** and radial reference lines **120**. Although reference lines **110/120** are visible on a macroscopic level, it can be appreciated by those skilled in the art that rotation of the polymer member **100** in the semi molten state results in molecular helical orientation only visible on the microscopic level. By comparison, it can be seen that rotation of the polymer member **100** in the molten state downstream of the extrusion head **20** results in a helical orientation of the reference lines **110/120**. By the cross sectional views shown in **FIGS. 4A and 4B**, it can be appreciated that the helical orientation extends through the entire cross section of the polymer member **100B**.

[0033] The polymer member **100** may be rotated at speeds of 1000 rpm or more, and preferably at 3,500 rpm or more. The extrusion rate may range from 10 fpm to 100 fpm, and preferably 20 fpm to 50 fpm. The resulting helical orientation ranges from 10 rotations per foot (rpf) to 350 rpf, and preferably ranges from 70 rpf to 175 rpf. The extrusion rate and/or the rotation rate may be varied during the extrusion process to vary the degree of molecular orientation at various positions along the elongate polymer member **100**.

[0034] As mentioned previously, the elongate polymer member **100** may comprise a single polymer extrusion or a multiple-polymer co-extrusion. **FIG. 6** is a longitudinal sectional view of a polymeric tubular member **100** formed by intermittent co-extrusion. **FIG. 7** is a plan view of a polymeric extrusion member **100** formed by continuous co-extrusion. As seen in **FIG. 6**, an intermittent co-extrusion process results in a polymeric extrusion member **100** comprising a first material **102** and a second material **104** disposed end-to-end, both of which have molecular helical orientation. With the exception of rotation downstream of the extrusion head, this type of co-extrusion is generally described in U.S. Pat. No. 5,533,985 to Wang, the entire disclosure of which is hereby incorporated by reference. As seen in **FIG. 7**, a continuous co-extrusion process results in a polymeric extrusion member **100** comprising a first polymeric material **102** and a second polymeric material **104** forming a helical band, both of which have molecular helical orientation. With the exception of rotation downstream of the extrusion head, this type of co-extrusion is generally described in U.S. Pat. No. 5,639,409 to Van Muiden, the entire disclosure of which is hereby incorporated by reference.

[0035] The polymeric extrusion member **100** may be incorporated into a wide variety of medical devices such as an intravascular catheter **200** illustrated in **FIG. 8**. Specifically, the elongate polymer member **100** having molecular

helical orientation may be incorporated into the shaft **210** and/or the balloon **220** of the intravascular balloon catheter **200**. In either case, the extruded polymeric member **100** may comprise a tubular member having one or more lumens extending therethrough. If incorporated into the inflatable balloon **220** of the intravascular balloon catheter **200**, the polymeric tubular member **100** may comprise the balloon blank which is formed into the balloon **220** by a conventional blow-molding process. By incorporating the polymeric extrusion **100** into a catheter shaft **210**, the molecular helical orientation improves kink-resistance and also allows for variable stiffness. By utilizing the polymeric member **100** to form the balloon **220**, the molecular helical orientation provides better puncture resistance and higher burst strength, and may also be used to alter the compliance of the balloon **220**. By utilizing the polymeric member **100** to form the balloon sleeve **222**, the molecular helical orientation provides more flexibility such that the sleeve portion **222** behaves similar to the shaft **210**, which is particularly beneficial if relatively stiff balloon materials are used to obtain the desired balloon performance.

[0036] By way of example, a catheter shaft **210** was made from a single-layered polymeric tube **100** formed from polyether block amide (PEBAX 7233 SA01) having 30% LCP (LKX1111) mixed therein. The tubing **100** was extruded and rotated at 3500 rpm in accordance with the present invention to have an inside diameter of 0.018 inches and an outside diameter 0.023 inches. The resulting shaft **210** exhibited better kink resistance than that formed without helical orientation. In addition, the helical orientation reduces the brittleness of shaft **210**, particularly when high content LCP is used.

[0037] Also by way of example, a balloon **220** was made from a multi-layered polymeric tube **100** having seven layers. The first, third, fifth and seventh layers were formed from polyether block amide (PEBAX 7233 SA01), and the second, fourth and sixth layers were formed from polyether block amide (PEBAX 7233 SA01) having 10% LCP (LKX1111) mixed therein. The tubing **100** was extruded and rotated at 3500 rpm in accordance with the present invention to have an inside diameter of 0.0175 inches and an outside diameter 0.0345 inches. The extruded tubing **100** was blow-molded to form a balloon **220** having an outside diameter of 3.0 mm, a length of 20 mm, and a wall thickness of 0.007 inches. The balloon **220** was tested to have a burst strength of 27198 psi at a burst pressure of 309 psi.

[0038] The polymeric extrusion member **100** may also be incorporated into an intravascular guide wire **300** illustrated in **FIG. 9**. The elongate tubular member **100** may comprise a solid cross section to form the shaft **310** or a tubular cross section to be disposed about a metallic core member of the shaft **310**. By incorporating the polymeric extrusion **100** into a guide wire shaft **310**, the molecular helical orientation improves kink-resistance and torque transmission, and also allows for variable stiffness.

[0039] Those skilled in the art will recognize that the present invention may be manifested in a variety of forms other than the specific embodiments described and contemplated herein. Accordingly, departures in form and detail may be made without departing from the scope and spirit of the present invention as described in the appended claims.

What is claimed is:

1. A method of polymer extrusion, comprising the steps of:

providing an extruder having an extrusion head;

extruding an elongate polymer member;

solidifying the elongate polymer member; and

rotating the elongate polymer member downstream of the extrusion head prior to solidification in order to impart molecular helical orientation to the elongate polymer member.

2. A method of polymer extrusion as in claim 1, wherein the step of rotating the polymer member downstream of the extrusion head is performed in close proximity to the extrusion head such that the molecular helical orientation is imparted to the elongate polymer member in a molten state.

3. A method of polymer extrusion as in claim 2, wherein the polymer member is formed of a polymer having a melting temperature and a glass transition temperature, and wherein the step of rotating the polymer member downstream of the extrusion head is performed in close proximity to the extrusion head such that the molecular helical orientation is imparted to the elongate polymer below the melting temperature.

4. A method of polymer extrusion as in claim 3, wherein the step of rotating the polymer member downstream of the extrusion head is performed in close proximity to the extrusion head such that the molecular helical orientation is imparted to the elongate polymer above the glass transition temperature.

5. A method of polymer extrusion as in claim 4, wherein the elongate polymer member is extruded at 10 fpm or more and rotated at 1000 rpm or more.

6. A method of polymer extrusion as in claim 5, wherein the elongate polymer member is rotated at 3500 rpm or more.

7. A method of polymer extrusion as in claim 5, wherein the elongate polymer member is rotated at a variable speed to vary the molecular helical orientation imparted to the elongate polymer member.

8. A method of polymer extrusion as in claim 4, wherein the step of extruding the elongate polymer member comprises co-extruding two or more polymers.

9. A method of polymer extrusion as in claim 8, wherein the step of co-extruding two or more polymers comprises intermittently co-extruding two or more polymers.

10. A method of polymer extrusion as in claim 8, wherein the step of co-extruding two or more polymers comprises continuously co-extruding two or more polymers.

11. A method of polymer extrusion as in claim 4, wherein the elongate polymer member is extruded over a core member.

12. A method of polymer extrusion as in claim 11, wherein the core member is rotated with the elongate polymer member.

13. A method of polymer extrusion as in claim 12, wherein the core member is removed from the polymer member.

14. A method of polymer extrusion as in claim 4, further comprising the steps of:

feeding the elongate polymer member back into the extruder as a core member;

extruding a second elongate polymer member over the core member;

solidifying the second elongate polymer member; and

rotating the second elongate polymer member downstream of the extrusion head prior to solidification in order to impart molecular helical orientation to the second elongate polymer member.

15. A method of polymer extrusion as in claim 14, wherein the second polymer member is rotated in a different direction than the first polymer member.

16. A medical device comprising an elongate polymer member made by an extrusion process including the step of rotating the polymer member after extrusion but prior to solidification while the polymer member is still in a molten state to impart a molecular helical orientation to the polymer member.

17. A medical device as in claim 16, wherein the elongate polymer member has a surface and a body, and wherein the molecular helical orientation extends through the surface and the body.

18. A medical device as in claim 16, wherein elongate polymer member is made by a co-extrusion process of two or more different polymers.

19. A medical device as in claim 18, wherein elongate polymer member is made by an intermittent co-extrusion process of two or more different polymers such that a proximal portion of the elongate polymer member comprises a first polymer and a distal portion of the elongate polymer member comprises a second polymer.

20. A medical device as in claim 18, wherein elongate polymer member is made by a continuous co-extrusion process of two or more different polymers such that the elongate polymer member comprises two or more coextending helically oriented polymers.

21. A medical device as in claim 16, wherein the molecular helical orientation comprises 100 rotations per foot or more.

22. A medical device as in claim 21, wherein the molecular helical orientation varies as a function of length of the elongate tubular member to impart variable flexibility.

23. A medical device as in claim 16, wherein the medical device comprises a guide wire and the elongate polymer member forms a shaft of the guide wire.

24. A medical device as in claim 16, wherein the medical device comprises a catheter and the elongate polymer member forms a tubular shaft of the catheter.

25. A medical device as in claim 16, wherein the medical device comprises a balloon catheter and the elongate polymer member forms a balloon of the balloon catheter.

26. A medical device as in claim 16, wherein the medical device comprises a balloon catheter and the elongate polymer member forms a balloon sleeve of the balloon catheter.

27. A medical device comprising an elongate polymer member having a molecular helical orientation formed by rotation immediately after extrusion thereof.

专利名称(译)	具有螺旋取向的挤压构件的医疗装置		
公开(公告)号	US20030009114A1	公开(公告)日	2003-01-09
申请号	US09/898710	申请日	2001-07-03
申请(专利权)人(译)	SCIMED LIFE SYSTEMS INC.		
当前申请(专利权)人(译)	SCIMED LIFE SYSTEMS INC.		
[标]发明人	CHIN ALBERT CHEN JOHN WANG LIXIAO SAHATJIAN RONALD WANG YIQUN		
发明人	CHIN, ALBERT CHEN, JOHN WANG, LIXIAO SAHATJIAN, RONALD WANG, YIQUN		
IPC分类号	B29C47/00 A61M25/00 A61M25/16 B29C47/06 B29C48/355 B29C53/14 B29L9/00 A61B5/00 D01D5/20		
CPC分类号	A61M25/0009 A61M25/0045 B29C47/0023 B29C47/065 B29C47/26 B29C47/28 B29C47/34 B29C53/14 B29K2995/005 B29L2031/7542 B29C48/09 B29C48/21 B29C48/30 B29C48/335 B29C48/34 B29C48/355		
其他公开文献	US6776945		
外部链接	Espacenet USPTO		

摘要(译)

一种细长的聚合物构件，其具有通过在挤出头之后立即旋转形成的分子螺旋取向。在凝固之前，细长聚合物构件在熔融状态下在挤出头的下游旋转，以赋予分子螺旋取向。使聚合物构件在熔融状态下旋转允许在分子水平上赋予螺旋取向，并允许每个线性挤压脚更多的旋转。

