



US008529476B2

(12) **United States Patent**
Govari

(10) **Patent No.:** **US 8,529,476 B2**
(45) **Date of Patent:** **Sep. 10, 2013**

(54) **CATHETER WITH STRAIN GAUGE SENSOR**

(75) Inventor: **Assaf Govari**, Haifa (IL)
(73) Assignee: **Biosense Webster (Israel), Ltd.**,
Yokneam (IL)
(*) Notice: Subject to any disclaimer, the term of this
patent is extended or adjusted under 35
U.S.C. 154(b) by 741 days.

6,574,492	B1	6/2003	Ben-Haim et al.	
6,612,992	B1	9/2003	Hossack et al.	
7,604,605	B2 *	10/2009	Zvuloni	600/587
2007/0100332	A1 *	5/2007	Paul et al.	606/41
2007/0142749	A1 *	6/2007	Khatib et al.	600/587
2007/0282211	A1 *	12/2007	Ofek et al.	600/523
2008/0294144	A1	11/2008	Leo	
2009/0093806	A1	4/2009	Govari et al.	
2009/0138007	A1	5/2009	Govari	
2010/0063478	A1 *	3/2010	Selkee	604/524

(21) Appl. No.: **12/647,824**

(22) Filed: **Dec. 28, 2009**

(65) **Prior Publication Data**

US 2011/0160556 A1 Jun. 30, 2011

(51) **Int. Cl.**
A61B 5/00 (2006.01)

(52) **U.S. Cl.**
USPC **600/595**

(58) **Field of Classification Search**
USPC 600/587, 595
See application file for complete search history.

(56) **References Cited**

U.S. PATENT DOCUMENTS

3,841,150	A *	10/1974	Pearson	73/766
3,971,364	A	7/1976	Fletcher et al.	

FOREIGN PATENT DOCUMENTS

WO WO 2007/050960 A2 5/2007

* cited by examiner

Primary Examiner — Max Hindenburg

(74) *Attorney, Agent, or Firm* — William A. Schoneman

(57) **ABSTRACT**

A medical probe, including a flexible insertion tube, having a distal end for insertion into a body cavity of a patient and which is configured to be brought into contact with tissue in the body cavity. The probe further includes a sensor tube of an elastic material, contained inside the distal end of the insertion tube and configured to deform in response to forces exerted by the tissue on the distal end. The probe also includes a plurality of strain gauges fixedly attached to a surface of the sensor tube at different, respective locations and configured to generate respective signals in response to deformations of the sensor tube.

20 Claims, 4 Drawing Sheets

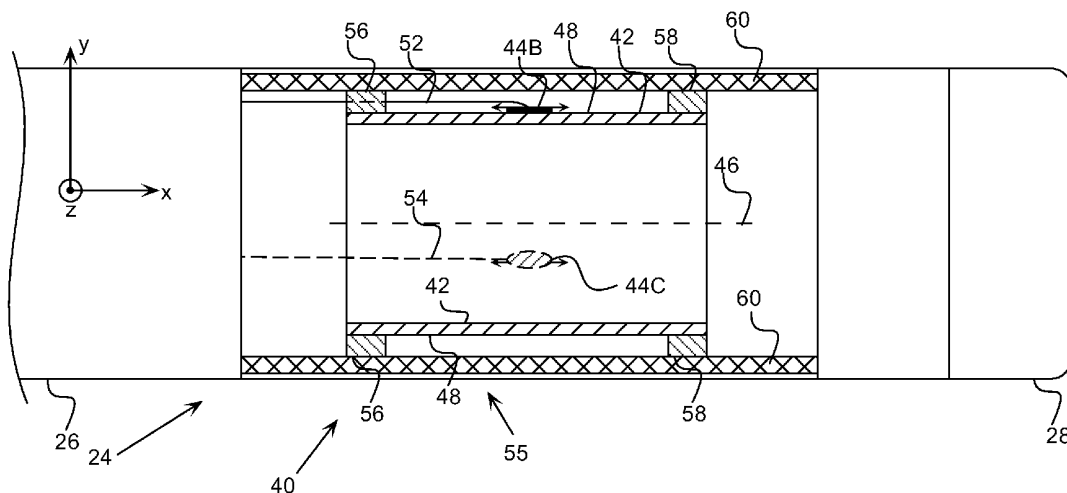

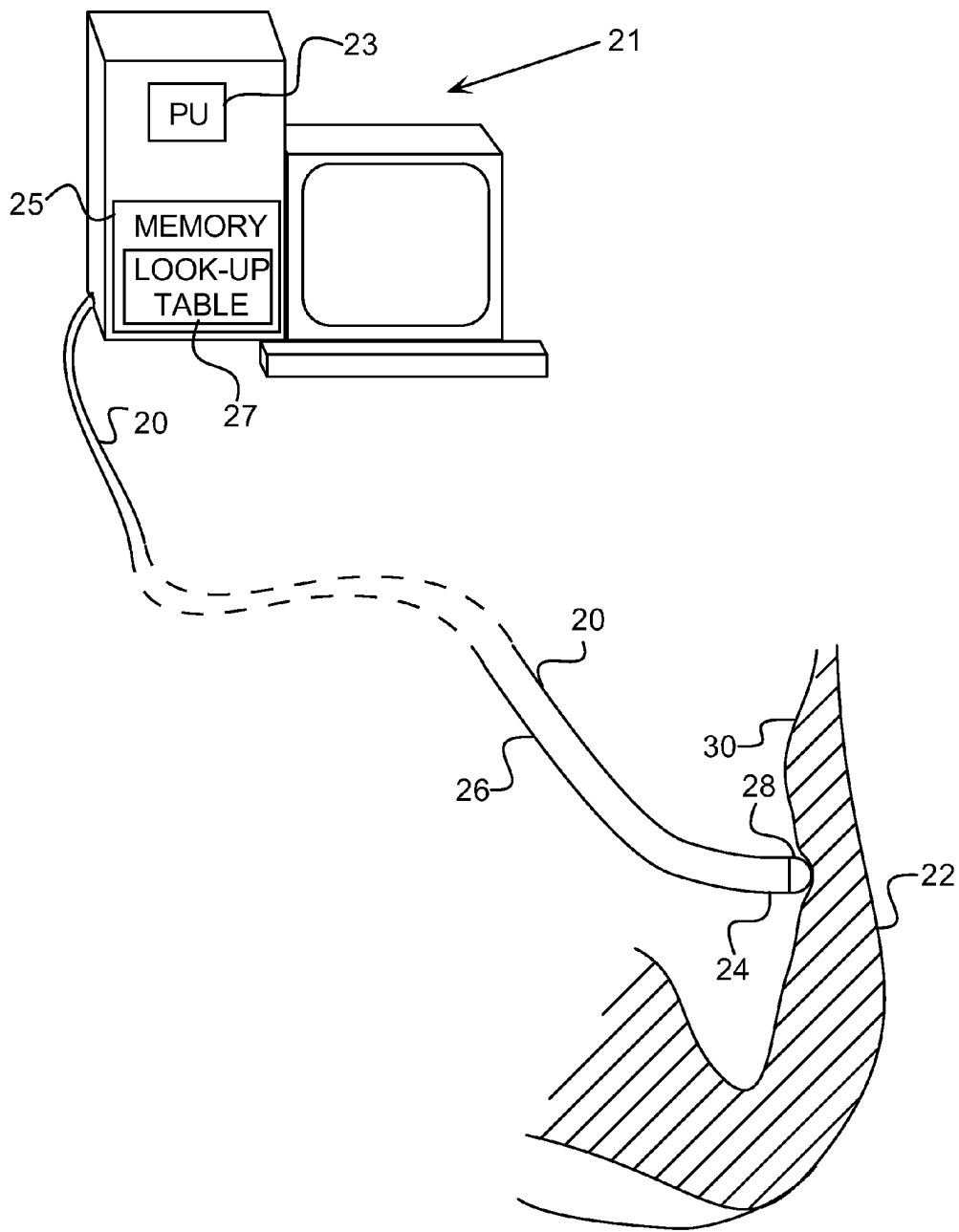
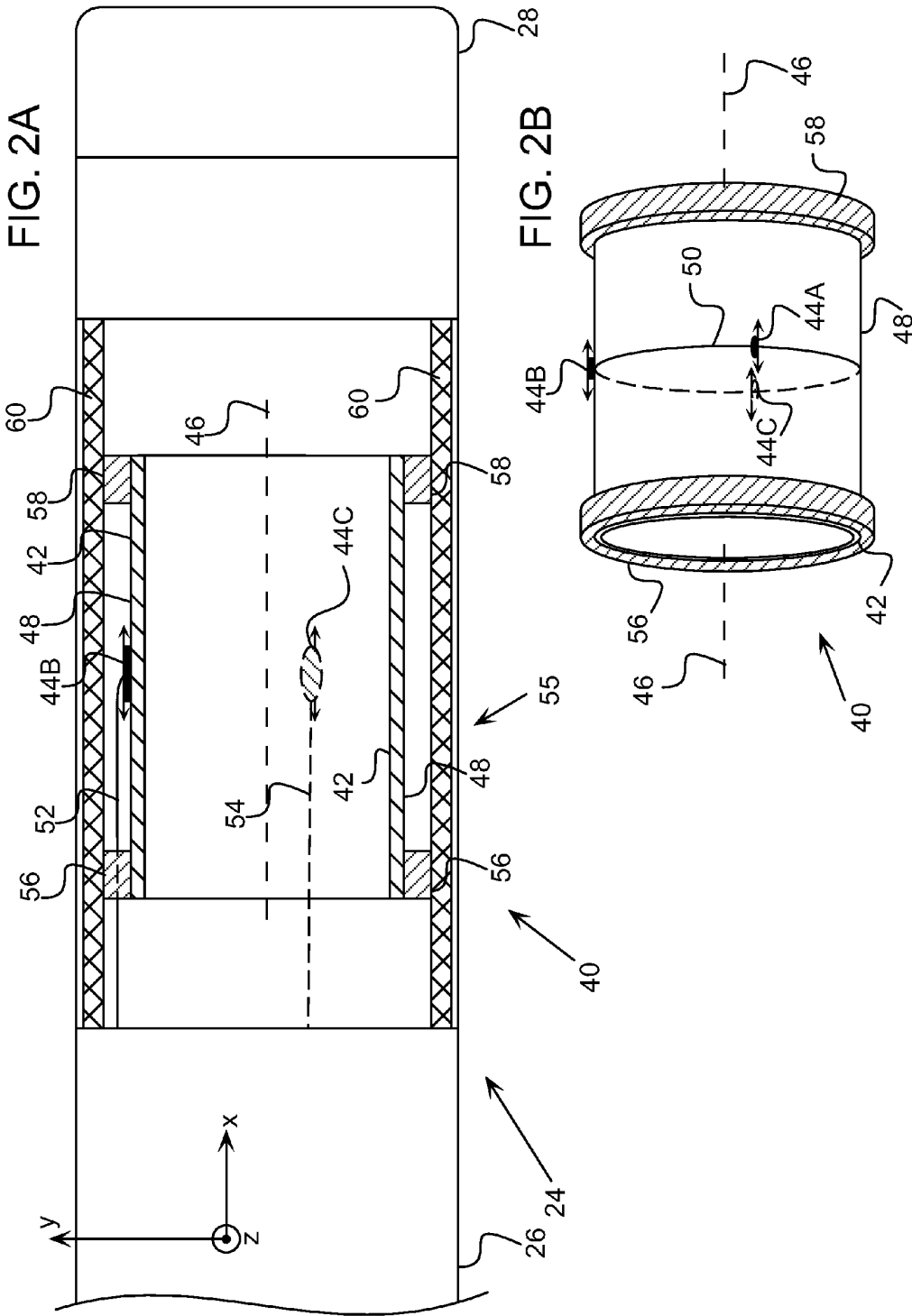

FIG. 1



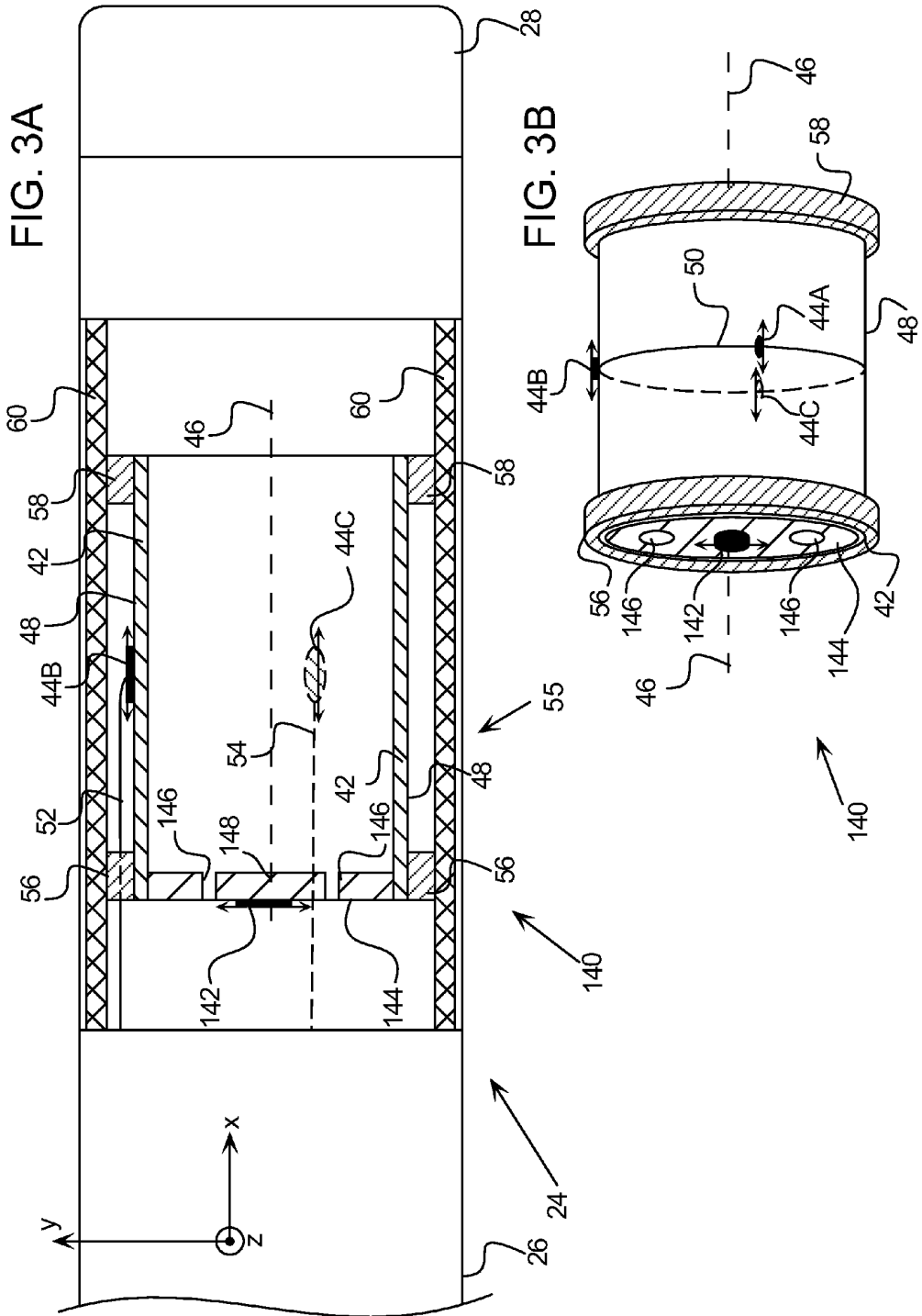

FIG. 4

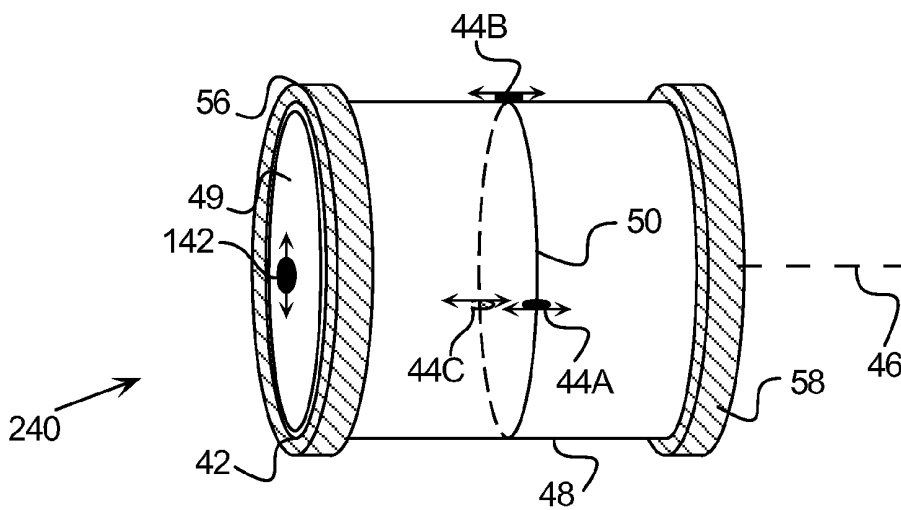
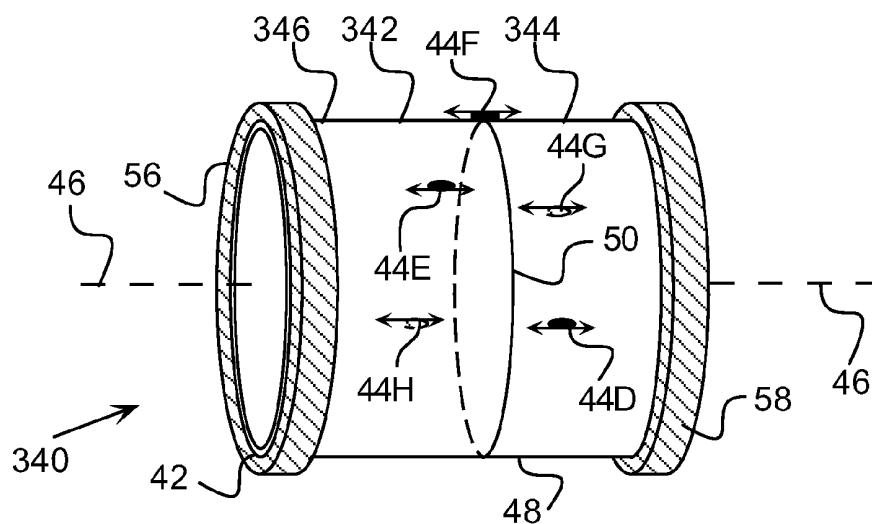

FIG. 5



CATHETER WITH STRAIN GAUGE SENSOR

FIELD OF THE INVENTION

The present invention relates generally to invasive medical devices, and specifically to the construction of probes for insertion into body organs.

BACKGROUND OF THE INVENTION

In some diagnostic and therapeutic techniques, a catheter is inserted into a chamber of the heart and is brought into contact with the inner heart wall. In such procedures, it is generally important that the distal tip of the catheter engages the endocardium with sufficient pressure to ensure good contact. Excessive pressure, however, may cause undesired damage to the heart tissue and even perforation of the heart wall.

For example, in intracardiac radio-frequency (RF) ablation, a catheter having an electrode at its distal tip is inserted through the patient's vascular system into a chamber of the heart. The electrode is brought into contact with a site (or sites) on the endocardium, and RF energy is applied through the catheter to the electrode in order to ablate the heart tissue at the site. Proper contact between the electrode and the endocardium during ablation is necessary in order to achieve the desired therapeutic effect without excessive damage to the tissue.

A number of patent publications describe catheters with integrated pressure sensors for sensing tissue contact. As one example, U.S. Patent Application Publication 2007/0100332 to Saurav et al., whose disclosure is incorporated herein by reference, describes systems and methods for assessing electrode-tissue contact for tissue ablation. An electro-mechanical sensor within the catheter shaft generates electrical signals corresponding to the amount of movement of the electrode within a distal portion of the catheter shaft. An output device receives the electrical signals for assessing a level of contact between the electrode and a tissue.

The description above is presented as a general overview of related art in this field and should not be construed as an admission that any of the information it contains constitutes prior art against the present patent application.

SUMMARY OF THE INVENTION

An embodiment of the present invention provides a medical probe, including:

a flexible insertion tube, having a distal end for insertion into a body cavity of a patient and which is configured to be brought into contact with tissue in the body cavity;

a sensor tube including an elastic material, contained inside the distal end of the insertion tube and configured to deform in response to forces exerted by the tissue on the distal end; and

a plurality of strain gauges fixedly attached to a surface of the sensor tube at different, respective locations and configured to generate respective signals in response to deformations of the sensor tube.

Typically, the sensor tube is fixedly attached inside the distal end to the insertion tube, and the surface of the sensor tube may include an outer curved surface of the sensor tube.

In one embodiment the respective signals are configured to generate a magnitude and a direction of a pressure on a termination of the distal end. Alternatively or additionally, the respective signals are configured to generate a magnitude and a direction of a deflection of a termination of the distal end.

The plurality of strain gauges may be symmetrically disposed with respect to an axis of the sensor tube, and addition-

ally may be positioned on a circumference of the surface of the sensor tube, wherein the circumference is centrally located with respect to the sensor tube.

In a disclosed embodiment the plurality of strain gauges have respective gauge directions, and the gauges are fixedly attached to the surface of the sensor tube so that the respective gauge directions are parallel to an axis of the sensor tube.

In a further disclosed embodiment the probe includes at least one temperature-compensating strain gauge configured to generate signals to compensate for changes in temperature of the plurality of strain gauges. The at least one temperature-compensating strain gauge may be mounted on a block having a block-thermal mass, and the sensor tube may have an assembly-tube-thermal mass equal to the block-thermal mass.

The at least one temperature-compensating strain gauge may be mounted on the block in a location that does not deform in response to deformations of the sensor tube.

The at least one temperature-compensating strain gauge may have a temperature-compensating strain gauge direction configured to be orthogonal to an axis of the sensor tube.

There is further provided, according to a disclosed embodiment of the present invention, a method for producing a medical probe, including:

providing a flexible insertion tube, having a distal end for insertion into a body cavity of a patient and which is configured to be brought into contact with tissue in the body cavity;

installing a sensor tube including an elastic material inside the distal end of the insertion tube, the sensor tube being configured to deform in response to forces exerted by the tissue on the distal end; and

fixedly attaching a plurality of strain gauges to a surface of the sensor tube at different, respective locations, the strain gauges being configured to generate respective signals in response to deformations of the sensor tube.

There is further provided, according to a disclosed embodiment of the present invention, apparatus for performing a medical procedure, including:

a medical probe, including:

a flexible insertion tube, having a distal end for insertion into a body cavity of a patient and which is configured to be brought into contact with tissue in the body cavity;

a sensor tube including an elastic material, contained inside the distal end of the insertion tube and configured to deform in response to forces exerted by the tissue on the distal end; and

a plurality of strain gauges fixedly attached to a surface of the sensor tube at different, respective locations and configured to generate respective signals in response to deformations of the sensor tube; and

a console, which receives the respective signals from the strain gauges and in response provides an indication of the forces on the distal end.

There is further provided, according to a disclosed embodiment of the present invention, a method for performing a medical procedure, including:

providing a flexible insertion tube, having a distal end for insertion into a body cavity of a patient and which is configured to be brought into contact with tissue in the body cavity;

installing a sensor tube including an elastic material inside the distal end of the insertion tube, the sensor tube being configured to deform in response to forces exerted by the tissue on the distal end;

fixedly attaching a plurality of strain gauges to a surface of the sensor tube at different, respective locations, the strain gauges being configured to generate respective signals in response to deformations of the sensor tube;

receiving the respective signals at a console; and

providing at the console an indication of the forces on the distal end in response to receiving the respective signals.

The present invention will be more fully understood from the following detailed description of the embodiments thereof, taken together with the drawings in which:

BRIEF DESCRIPTION OF THE DRAWINGS

FIG. 1 is a schematic illustration of operation of a catheter, according to an embodiment of the present invention;

FIG. 2A is a schematic, cutaway view of the catheter, showing a pressure sensing assembly, and FIG. 2B is a schematic perspective view of the pressure sensing assembly, according to an embodiment of the present invention;

FIG. 3A is a schematic, cutaway view of the catheter, showing an alternative pressure sensing assembly, and FIG. 3B is a schematic perspective view of the alternative pressure sensing assembly, according to an embodiment of the present invention;

FIG. 4 is a schematic perspective view of a further alternative pressure sensing assembly, according to an embodiment of the present invention; and

FIG. 5 is a schematic perspective view of a yet further alternative pressure sensing assembly, according to an embodiment of the present invention.

DETAILED DESCRIPTION OF EMBODIMENTS OVERVIEW

Embodiments of the present invention provide a novel design of an invasive probe, such as a catheter. The probe comprises a flexible insertion tube for insertion into a body cavity of a patient, and a pressure sensing assembly is installed inside the distal end of the insertion tube. The assembly comprises a tube of elastic material having a plurality of strain gauges fixedly attached to different respective locations of a surface, typically the outer curved surface, of the tube. Typically, three or more strain gauges are fixedly attached to the surface.

When the distal end of the probe engages tissue in the body cavity, force on the end causes the probe to bend and/or compress, and the tube of elastic material to deform. Depending on the magnitude and direction of the force relative to the tube, the deformation of the tube consists of expansion and/or contraction of the locations of the tube's surface to which the strain gauges are attached. The strain gauges provide respective signals in response to the deformation of the locations of the tube to which the gauges are attached, and a processing unit calculates the pressure (caused by the force) on the end, from the strain gauge signals. The processing unit may also calculate a deflection of the end from the signals.

The combination of strain gauges attached to an elastic tube provides a reliable, accurate, pressure sensing device that is simpler and cheaper to manufacture than other pressure sensing devices known in the art.

DETAILED DESCRIPTION

FIG. 1 is a schematic illustration of operation of a catheter 20, according to an embodiment of the present invention. As is illustrated in FIG. 1, a proximal end of catheter 20 is coupled to an operating console 21, which is controlled by an operator of the catheter. The operator also manipulates the catheter using controls (not shown) while the catheter is being used to perform a medical procedure. Console 21 comprises a processing unit (PU) 23, which, inter alia, receives and analyzes signals from elements at a distal end of catheter 20.

The elements and the signal analysis are described in more detail below. Processing unit 23 uses software stored in a memory 25, the software typically including a look-up table 27, for the signal analysis, as well as for performing other functions related to operation of the catheter. The software may be downloaded to console 21 in electronic form, over a network, for example, or it may, alternatively or additionally, be provided and/or stored on tangible media, such as magnetic, optical, or electronic memory.

Catheter 20 comprises a flexible insertion tube 26. A lower portion of FIG. 1 schematically illustrates a sectional view of a chamber of a heart 22, showing flexible insertion tube 26 of the catheter 20 inside the heart. The catheter is typically inserted into the heart percutaneously through a blood vessel, such as the vena cava or the aorta. A termination 28 of tube 26, fixedly attached to a distal end 24 of the tube, engages endocardial tissue 30. Typically termination 28 comprises an electrode, which may be used for ablation. However, there is no requirement that termination 28 comprises an electrode and the termination may comprise any other element, such as a camera. For simplicity, in the following description termination 28 is assumed to comprise an electrode, and those having ordinary skill in the art will be able to adapt the description, mutatis mutandis, for other types of termination. Force exerted by termination 28 against the endocardium deforms the endocardial tissue locally, and leads to a countervailing force from the endocardium on the termination.

In the pictured example, termination 28 engages the endocardium head-on. The countervailing force causes distal end 24 of insertion tube 26 to compress slightly. Alternatively (not pictured), the termination engages the endocardium at an angle. In this case, the countervailing force from the endocardium bends distal end 24 of the tube, and may also compress the distal end. As is explained in more detail below, embodiments of the present invention measure either type of deformation, due to head-on or angled engagement, and the measurements provide an indication of the direction and magnitude of the force, and also of the pressure, causing the deformation. (The measurements may also provide an indication of the deflection of termination 28.)

The pressure indication may be used by the operator of catheter 20 to ensure that termination 28 is pressing against the endocardium firmly enough, and in a required direction, to give the desired result, but not so hard or in a direction as to cause undesired tissue damage. U.S. Patent Application 20090093806, to Govari et al., filed Oct. 8, 2007, whose disclosure is incorporated herein by reference, describes a system that uses a pressure-sensing catheter in a similar manner. Catheter 20 may be used in such a system.

The deflection indication may be used by the operator to judge if termination 28 is correctly positioned.

FIG. 2A is a schematic, cutaway view of catheter 20, showing a pressure sensing assembly 40 installed in distal end 24 of insertion tube 26, and FIG. 2B is a schematic perspective view of the pressure sensing assembly, according to an embodiment of the present invention. Pressure sensing assembly 40 comprises a thin-walled tube 42 of an elastic material, typically a metal material, and the tube is herein also referred to as sensor tube 42. The sensor tube is typically in the form of a hollow right circular cylinder, having an axis of symmetry 46. The elastic material forming the tube may comprise a superelastic alloy such as nickel titanium (Nitinol). For intracardiac applications, the overall length of tube 42 may be approximately 5 mm, with a wall thickness of approximately 0.1 mm, and an outer diameter of approxi-

mately 2 mm. Alternatively, in other applications, the dimensions of sensor tube 42 may be larger or smaller than those exemplified above.

For clarity, in the following description, sensor tube 42 is assumed to be oriented and aligned with a set of xyz orthogonal axes, as shown in FIG. 2A, (the x- and y-axes being in the plane of the paper) so that axis 46 is parallel to the x-axis. However, it will be appreciated that embodiments of the present invention may function in substantially any orientation.

A plurality of strain gauges 44A, 44B, 44C, . . . are fixedly attached to a surface 48 of sensor tube 42. In the following description, except where otherwise indicated, surface 48 is assumed to comprise the outer curved surface of tube 42. Strain gauges 44A, 44B, 44C, . . . are also referred to herein generically as strain gauges 44 and are also referred to as strain-measuring gauges 44.

Typically, strain gauges 44 are of generally similar types. A number of different types of strain gauges, i.e., gauges that provide an indication of the amount of deformation of a material, are known in the art. For example, strain gauges 44 may comprise metallic foil gauges or semiconductor gauges (the latter using a piezoresistive effect), which respectively indicate strain by a change in resistance of a metal or a semiconductor. Alternatively, strain gauges 44 may comprise other devices capable of providing an indication of strain, such as a piezoelectric crystal, which indicates strain according to a potential developed across the crystal in response to the strain, or a fiber optic, which indicates strain by a change in a characteristic of the fiber optic, such as a resonant wavelength of a diffraction grating formed in the fiber optic. The fiber optic characteristic is typically evaluated by radiation transmitted through the fiber optic.

In the description and in the claims, the terms strain gauge and strain-measuring gauge are assumed to comprise any device, such as those exemplified above, which is able to provide an indication of strain. For simplicity, except where otherwise indicated, in the following description strain-measuring gauges 44 are assumed to comprise metallic foil gauges.

Strain gauges typically measure strain in a particular direction, herein termed the "gauge direction," relative to the gauge. In the figures, the gauge direction for a particular gauge is indicated by a double-headed arrow adjoining the symbol for the gauge. Thus, by way of example and as shown in FIGS. 2A and 2B, strain gauges 44 have a common alignment, so that their gauge directions are parallel to the x-axis. However, there is no requirement that the gauge direction of strain gauges 44 have a common alignment, and in some embodiments the gauge directions are different.

In the following description of a disclosed embodiment, there are assumed to be three strain-measuring gauges 44A, 44B, and 44C, which are symmetrically disposed with respect to sensor tube 42. It will be understood that such a symmetric disposition of the strain gauges with respect to the sensor tube facilitates determining the magnitude and direction of the pressure exerted on termination 28, as well as the magnitude and direction of the deflection of the termination, regardless of the direction of the pressure. Also in the disclosed embodiment, strain gauges 44A, 44B, and 44C are fixedly attached to tube 42 on a common circumference 50 of an outer surface of the tube. Common circumference 50 is typically approximately centrally positioned with respect to tube 42, and is orthogonal to axis 46 so that it lies in a yz plane. It will be understood that central positioning of circumference 50 typically enhances values read from gauges 44 for a given pressure on termination 28.

The attachment of the gauges may be implemented using any convenient bonding material, such as a cyanoacrylate based adhesive. The gauges are typically attached so that they are disposed symmetrically on circumference 50, and so that their gauge directions are as described above, i.e., parallel to the x-axis.

However, in other embodiments of the present invention, the plurality of strain-measuring gauges 44 may comprise any integral number greater than or equal to 2, and there is no requirement that the plurality be disposed symmetrically with respect to tube 42. An embodiment with an asymmetric disposition of strain gauges is described with reference to FIG. 5 below.

Each strain gauge 44 is typically connected by respective cabling to processing unit 23 (FIG. 1). In FIG. 2A, cabling 52 to gauge 44B and cabling 54 to gauge 44C are shown. The cabling to strain gauges 44 is also referred to herein generically as cabling 55. Depending on the type of strain gauge, cabling 55 may typically comprise a twisted-pair cable or a fiber optic cable. Signals are transferred via the cabling to processing unit 23, which is configured to analyze the signals so as to determine the strain of each gauge.

Insertion tube 26 of the catheter comprises an outer flexible tubular sheath 60, which encloses operative portions of the catheter. The operative portions include elements such as conductive cabling and/or fluid-carrying tubing and/or pull-wires to guide catheter 20. For simplicity, these operative portions of the catheter are not shown in FIG. 2A. Sheath 60 typically comprises a composition of plastic with strengthening elements, such as metallic wiring, included in the composition.

Pressure sensing assembly 40 is fixedly attached to sheath 60. By way of example, the attachment is assumed to be implemented by two generally similar rings 56, 58. Rings 56, 58 have internal diameters equal to the external diameter of sensor tube 42, and external diameters equal to the internal diameter of sheath 60. Rings 56, 58 are typically positioned at respective ends of the sensor tube. During positioning, assembly 40 may be fixedly attached to sheath 60 by application of an adhesive or cement to the internal and external circumferences of rings 56, 58. Rings 56, 58 are typically configured so that, on attachment of assembly 40 to sheath 60, the assembly is symmetrically disposed with respect to the sheath, i.e., with respect to distal end 24.

Rings 56, 58 are one possible method by which assembly 40 is fixedly attached to sheath 60. Those having ordinary skill in the art will understand that other methods for attachment, for example using a plurality of spacers between the assembly and the sheath, may be used instead of, or in addition to, rings 56, 58. All such methods are assumed to be comprised within the scope of the present invention.

Once assembly 40 has been fixedly installed in distal end 24, the assembly may be calibrated, prior to the catheter being used for an invasive procedure such as that described above. The calibration comprises applying forces, that are known in both magnitude and direction, to distal end 24, typically by applying such forces to termination 28. In the following description, it is assumed that the known forces are converted to corresponding known pressures, using an effective area of termination 28 upon which the forces are applied. The applied known pressures include ranges of head-on pressures, as well as ranges (in magnitude and direction) of angled pressures, and the pressures cause corresponding deformations in sensor tube 42. For each known pressure, measurements of the strain generated by gauges 44 attached to the sensor tube are recorded and stored as calibration parameters of catheter 20, for example as look-up table 27 in memory 25.

The applied known pressures generate corresponding respective deflections of termination 28. The deflections may be measured, in both direction and magnitude, and are assumed, by way of example, to also be incorporated in the calibration parameters of catheter 20.

It will be understood that the calibration procedure described above, i.e., generating a look-up table, is one of a number of methods that may be used to calibrate assembly 40.

Other methods for calibrating the assembly will be familiar to those having ordinary skill in the art. For example, a first function relating the magnitude of the pressure to the values of strain of gauges 44, and a second function relating the direction of the pressure to the values of strain of the gauges 44, may be formulated. Typically, both functions are in the form of polynomials having the values of the strains of gauges 44, as well as higher powers of the strain values, as variables of the polynomials, each variable being multiplied by a respective coefficient. Similar functions may be formulated for the deflections of termination 28. The calibration procedure described above is used to determine the values of the coefficients for the respective functions, typically by applying a fitting procedure to the functions.

The equations and coefficient values determined in the calibration may be stored in memory 25 as the calibration parameters referred to above.

All calibration methods such as those described above are assumed to be comprised within the scope of the present invention.

During an invasive procedure such as is exemplified above, processing unit 23 determines "raw" values of strain measured by each of gauges 44. The processing unit accesses the calibration parameters stored in memory 25, in order to evaluate from the raw strain values, values of the magnitude and the direction of the pressure on termination 28, as well as values of the magnitude and direction of the deflection of the termination. The determined values may be provided to the operator of catheter 20, typically as part of a graphic user interface displayed on console 21.

The determination of the values of the magnitude and the direction of the pressure, and of the deflection, by processing unit 23 typically involve operations on the raw values, such as smoothing and/or filtering. In addition, depending on the type of calibration parameters, further operations may be required. For example, if the calibration comprises look-up table 27, processing unit 23 may apply an operation such as interpolation or extrapolation to determine, from the measured strain values of gauges 44, the direction and magnitude of the pressure on termination 28, and/or of the deflection of the termination. All such operations will be familiar to those having ordinary skill in the art, and are assumed to be included within the scope of the present invention.

FIG. 3A is a schematic, cutaway view of catheter 20, showing a pressure sensing assembly 140 installed in distal end 24 of insertion tube 26, and FIG. 3B is a schematic perspective view of the pressure sensing assembly, according to an alternative embodiment of the present invention. Apart from the differences described below, the operation of assembly 140 is generally similar to that of assembly 40 (FIGS. 2A and 2B), and elements indicated by the same reference numerals in both assemblies 40 and 140 are generally similar in construction and in operation.

Readings from strain gauges 44 may be sensitive to temperature changes of the gauges. Because of its dimensions, sensor tube 42 has a low thermal mass, so that any changes in the ambient temperature around the tube typically cause corresponding changes in the temperature of gauges 44, affecting the accuracy of the values read from the gauges. Assembly

140 enables processing unit 23 to compensate for these changes, by incorporating one or more temperature-compensating strain gauges 142 in the assembly. Typically, gauges 142 are the same type of gauges as gauges 44, and are coupled by cabling similar to cabling 55 to PU 23. For simplicity, in FIGS. 3A and 3B only one temperature-compensating gauge 142 without cabling is shown.

In the alternative embodiment described herein, temperature-compensating gauges 142 are assumed to be mounted on a block 144, which has a thermal mass that is typically approximately the same as that of sensor tube 42. However, block 144, in contrast to tube 42, is configured and positioned in assembly 140 to be relatively inflexible when distal end 24 deforms. In addition, the gauge direction of temperature-compensating gauges 142 are typically set to be orthogonal to the gauge directions of gauges 44, so that in the embodiment described herein, the gauge directions of gauges 142 are orthogonal to axis 46. Thus, temperature-compensating gauges 142 have approximately the same temperature changes as gauges 44, but do not respond to the strains measured by gauges 44.

By way of example, block 144 is assumed to be a disk, having an external diameter equal to the internal diameter of tube 42. The block may be fixedly attached to sensor tube 42, for example, as illustrated in FIGS. 3A and 3B, by being positioned at the proximal end of the sensor tube, with a disk axis 148 congruent with axis 46. This arrangement facilitates the positioning of temperature-compensating gauges 142 so that their gauge directions are orthogonal to the gauge directions of gauges 44. Typically, block 144 comprises one or more apertures 146, which may be used to allow passage of elements such as cabling through sensor tube 42. In addition, the dimensions of apertures 146 may be adjusted so that the thermal mass of block 144 is approximately the same as that of tube 42.

Assembly 140 is calibrated substantially as described above for assembly 40. However, rather than using the "raw" values from strain gauges 44, as are used by processing unit 23 to calibrate assembly 40, the processing unit typically uses values of differences between strain-measuring gauges 44 and temperature-compensating strain gauges 142 to generate calibration parameters for assembly 140. Once the calibration of assembly 140 has been performed, during a procedure such as is described above, processing unit 23 typically uses difference values between the two types of gauges, and the assembly 140 calibration parameters, to determine the magnitude and direction of the pressure being applied to termination 28, as well as the deflection of the termination.

FIG. 4 is a schematic perspective view of a pressure sensing assembly 240, according to a further alternative embodiment of the present invention. Apart from the differences described below, the operation of assembly 240 is generally similar to that of assembly 140 (FIGS. 3A and 3B), and elements indicated by the same reference numerals in both assemblies 140 and 240 are generally similar in construction and in operation. Assembly 240 is typically installed within distal end 24 of catheter 20, substantially as is described above for assembly 140 (FIG. 3A).

In assembly 240, in contrast to assembly 140, temperature-compensating gauges 142 are not mounted on block 144, and the block does not form part of assembly 240. Rather, in assembly 240, gauges 142 are mounted on, or in proximity to, a region of sensor tube 42 that is not subject to the strains measured by gauges 44. Such regions, by way of example, comprise the ends of sensor tube 42, where the tube is fixedly attached to sheath 60 by rings 56, 58 (FIGS. 3A and 3B). Thus, as is exemplified by one temperature-compensating

gauge 142 illustrated in FIG. 4, gauges 142 may be mounted on an internal curved surface 49 of sensor tube 42, close to the proximal end of the tube. Alternatively or additionally, at least some gauges 142 may be mounted on outer curved surface 48, close to the proximal end of the sensor tube; in some cases the mounting may be beneath rings 56 or 58 by providing a recess in the rings.

As for assembly 140, in assembly 240 temperature-compensating gauges 142 are typically oriented so that their gauge directions are orthogonal to the gauge directions of strain gauges 44.

FIG. 5 is a schematic perspective view of a pressure sensing assembly 340, according to a yet further alternative embodiment of the present invention. Apart from the differences described below, the operation of assembly 340 is generally similar to that of assembly 40 (FIGS. 2A and 2B), and elements indicated by the same reference numerals in both assemblies 40 and 340 are generally similar in construction and in operation. Assembly 340 is typically installed within distal end 24 of catheter 20, substantially as is described above for assembly 40 (FIG. 2A).

By way of example, in assembly 340 strain-measuring gauges 44 are assumed to comprise five gauges 44D, 44E, 44F, 44G, and 44H. In contrast to assembly 40, in assembly 340 the five strain gauges 44 are not mounted on sensor tube 42 symmetrically. Rather, gauges 44D, 44E, 44F, 44G, and 44H are mounted in an asymmetric manner on the tube. Such an asymmetric disposition of gauges 44 with respect to the sensor tube may allow greater flexibility in positioning the strain gauges compared to a symmetric arrangement. Typically, gauges 44 are evenly distributed on either side of circumference 50, i.e., in a positive or a negative direction parallel to axis 46, with respect to the circumference. However, there is no necessity for such an even distribution, and an uneven distribution may be implemented in some embodiments.

The angles subtended by adjacent strain gauges 44 with axis 46, measured orthogonally to the axis, may be set to be approximately equal. The equalization of the angles facilitates determining the pressure exerted on termination 28 regardless of the direction of the pressure, as well as facilitating determining the deflection of the termination regardless of the pressure direction.

In some embodiments of the present invention, it may be desirable to measure the pressure exerted on termination 28, and/or the termination's deflection, if the pressure is in one or more predetermined directions. For example, catheters known in the art have pull-wires that bend the catheter in one or more particular predetermined directions. Embodiments of the present invention allow for measuring the pressure and the deflection in a predetermined direction by appropriate positioning of gauges 44.

For example, gauges 44E and 44D may be respectively repositioned to locations 342 and 344 on surface 48 of tube 42, the locations being selected so that gauges 44E, 44F, and 44D lie on a line 346 of surface 48, where line 346 is parallel to axis 46. Such an arrangement of gauges typically enables processing unit 23 to measure deformation of distal end 24 in predetermined directions, defined by being within the plane comprising line 346 and axis 46, more accurately than if gauges 44E and 44D are not repositioned. The pressure on, and/or the deflection of, termination 28 may consequently be measured more accurately. Other arrangements of gauges 44 on tube 42, for measurement of deformation of distal end 24 in a predetermined direction, will be apparent to those having ordinary skill in the art, and all such arrangements are assumed to be within the scope of the present invention.

It will be understood that features described above may be combined in ways that are not specifically described. As a first example, temperature-compensating gauges, such as are described with reference to assemblies 140 and 240, may be incorporated into assembly 340. As a second example, strain-measuring gauges, in assemblies such as assembly 340, may be arranged so that they are able to measure pressure substantially regardless of direction, and additionally or alternatively in one or more predetermined directions.

It will thus be appreciated that the embodiments described above are cited by way of example, and that the present invention is not limited to what has been particularly shown and described hereinabove. Rather, the scope of the present invention includes both combinations and subcombinations of the various features described hereinabove, as well as variations and modifications thereof which would occur to persons skilled in the art upon reading the foregoing description and which are not disclosed in the prior art.

What is claimed is:

1. A medical probe, comprising:
 - a flexible insertion tube, having a distal end for insertion into a body cavity of a patient and which is configured to be brought into contact with tissue in the body cavity;
 - a generally cylindrical thin-walled sensor tube comprising an elastic material, contained inside the distal end of the insertion tube and configured to deform in response to forces exerted by the tissue on the distal end wherein the sensor tube is fixedly attached around the circumference of each end of the sensor tube to the inside the distal end to the insertion tube; and
 - a plurality of strain gauges fixedly attached to a surface of the sensor tube at different, respective locations and configured to generate respective signals in response to deformations of the sensor tube.
2. The probe according to claim 1, wherein the surface of the sensor tube comprises an outer curved surface of the sensor tube.
3. The probe according to claim 1, wherein the respective signals are configured to generate a magnitude and a direction of a pressure on a termination of the distal end.
4. The probe according to claim 1, wherein the respective signals are configured to generate a magnitude and a direction of a deflection of a termination of the distal end.
5. The probe according to claim 1, wherein the plurality of strain gauges are symmetrically disposed with respect to an axis of the sensor tube.
6. The probe according to claim 1, wherein the plurality of strain gauges are positioned on a circumference of the surface of the sensor tube, and wherein the circumference is centrally located with respect to the sensor tube.
7. The probe according to claim 1, wherein the plurality of strain gauges have respective gauge directions, and wherein the gauges are fixedly attached to the surface of the sensor tube so that the respective gauge directions are parallel to an axis of the sensor tube.
8. A medical probe, comprising:
 - a flexible insertion tube, having a distal end for insertion into a body cavity of a patient and which is configured to be brought into contact with tissue in the body cavity;
 - a generally cylindrical thin-walled sensor tube comprising an elastic material, contained inside the distal end of the insertion tube and configured to deform in response to forces exerted by the tissue on the distal end;
 - a plurality of strain gauges fixedly attached to a surface of the sensor tube at different, respective locations and configured to generate respective signals in response to deformations of the sensor tube; and at least one tem-

perature-compensating strain gauge configured to generate signals to compensate for changes in temperature of the plurality of strain gauges wherein the at least one temperature-compensating strain gauge is mounted on a block having a block-thermal mass, and wherein the sensor tube has a sensor-tube-thermal mass equal to the block-thermal mass.

9. The probe according to claim 8, wherein the at least one temperature-compensating strain gauge is mounted on the block in a location that does not deform in response to deformations of the sensor tube.

10. The probe according to claim 8, wherein the at least one temperature-compensating strain gauge has a temperature-compensating strain gauge direction configured to be orthogonal to an axis of the sensor tube.

11. A method for producing a medical probe, comprising: providing a flexible insertion tube, having a distal end for insertion into a body cavity of a patient and which is configured to be brought into contact with tissue in the body cavity;

installing a generally cylindrical thin-walled sensor tube comprising an elastic material inside the distal end of the insertion tube, the sensor tube being configured to deform in response to forces exerted by the tissue on the distal end, wherein the sensor tube is fixedly attached around the circumference of each end of the sensor tube to the inside the distal end to the insertion tube; and fixedly attaching a plurality of strain gauges to a surface of the sensor tube at different, respective locations, the strain gauges being configured to generate respective signals in response to deformations of the sensor tube.

12. The method according to claim 11, wherein the surface of the sensor tube comprises an outer curved surface of the sensor tube.

13. The method according to claim 11, wherein the respective signals are configured to generate a magnitude and a direction of a pressure on a termination of the distal end.

14. The method according to claim 11, wherein the respective signals are configured to generate a magnitude and a direction of a deflection of a termination of the distal end.

15. The method according to claim 11, wherein the plurality of strain gauges are symmetrically disposed with respect to an axis of the sensor tube.

16. The method according to claim 11, wherein the plurality of strain gauges are positioned on a circumference of the surface of the sensor tube, and wherein the circumference is centrally located with respect to the sensor tube.

17. The method according to claim 11, wherein the plurality of strain gauges have respective gauge directions, and wherein the gauges are fixedly attached to the surface of the sensor tube so that the respective gauge directions are parallel to an axis of the sensor tube.

18. A method for producing a medical probe, comprising: providing a flexible insertion tube, having a distal end for insertion into a body cavity of a patient and which is configured to be brought into contact with tissue in the body cavity;

installing a generally cylindrical thin-walled sensor tube comprising an elastic material inside the distal end of the insertion tube, the sensor tube being configured to deform in response to forces exerted by the tissue on the distal end;

fixedly attaching a plurality of strain gauges to a surface of the sensor tube at different, respective locations, the strain gauges being configured to generate respective signals in response to deformations of the sensor tube; providing at least one temperature-compensating strain gauge configured to generate signals to compensate for changes in temperature of the plurality of strain gauges wherein the at least one temperature-compensating strain gauge is mounted on a block having a block-thermal mass, and wherein the sensor tube has a sensor-tube-thermal mass equal to the block-thermal mass.

19. The method according to claim 18, wherein the at least one temperature-compensating strain gauge is mounted on the block in a location that does not deform in response to deformations of the sensor tube.

20. The method according to claim 18, wherein the at least one temperature-compensating strain gauge has a temperature-compensating strain gauge direction configured to be orthogonal to an axis of the sensor tube.

* * * * *

专利名称(译)	带有应变传感器的导管		
公开(公告)号	US8529476	公开(公告)日	2013-09-10
申请号	US12/647824	申请日	2009-12-28
[标]申请(专利权)人(译)	GOVARI阿萨夫		
申请(专利权)人(译)	GOVARI阿萨夫		
当前申请(专利权)人(译)	生物传感韦伯斯特(以色列)有限公司.		
[标]发明人	GOVARI ASSAF		
发明人	GOVARI, ASSAF		
IPC分类号	A61B5/00		
CPC分类号	A61B5/065 A61B5/6885 A61B18/1492 A61B5/6852 A61B2019/465 A61B2019/467 Y10T29/49002 A61B2018/00351 A61B2090/065 A61B2090/067		
其他公开文献	US20110160556A1		
外部链接	Espacenet USPTO		

摘要(译)

一种医疗探针，包括柔性插入管，具有用于插入患者体腔的远端，并且构造成与体腔中的组织接触。探针还包括弹性材料的传感器管，其包含在插入管的远端内部并且被配置为响应于组织在远端上施加的力而变形。探针还包括多个应变仪，这些应变仪在不同的相应位置处固定地附接到传感器管的表面，并且被配置为响应于传感器管的变形而产生相应的信号。

