



US008103326B2

(12) **United States Patent**
Sweeney et al.

(10) **Patent No.:** **US 8,103,326 B2**
(45) **Date of Patent:** **Jan. 24, 2012**

(54) **DEVICE FOR MONITORING FLUID STATUS**

(75) Inventors: **Robert J. Sweeney**, Woodbury, MN (US); **Julio C. Spinelli**, Shoreview, MN (US); **Rodney W. Salo**, Fridley, MN (US)

(73) Assignee: **Cardiac Pacemakers, Inc.**, St. Paul, MN (US)

(*) Notice: Subject to any disclaimer, the term of this patent is extended or adjusted under 35 U.S.C. 154(b) by 593 days.

5,318,597 A	6/1994	Hauck et al.	
5,469,859 A	11/1995	Tsoglin et al.	
5,490,323 A	2/1996	Thacker et al.	
5,522,860 A	6/1996	Molin et al.	
5,642,734 A *	7/1997	Ruben et al.	600/506
5,722,997 A	3/1998	Nedungadi et al.	
5,817,135 A	10/1998	Cooper et al.	
5,824,029 A	10/1998	Weijand et al.	
5,978,707 A	11/1999	Krig et al.	
6,044,294 A	3/2000	Mortazavi et al.	
6,058,934 A *	5/2000	Sullivan	600/308
6,076,015 A	6/2000	Hartley et al.	
6,151,524 A	11/2000	Krig et al.	
6,161,042 A	12/2000	Hartley et al.	
6,292,689 B1 *	9/2001	Wallace et al.	600/547

(Continued)

(21) Appl. No.: **12/098,644**

(22) Filed: **Apr. 7, 2008**

(65) **Prior Publication Data**

US 2008/0188730 A1 Aug. 7, 2008

Related U.S. Application Data

(63) Continuation of application No. 10/909,926, filed on Aug. 2, 2004, now Pat. No. 7,356,366.

(51) **Int. Cl.**
A61B 5/00 (2006.01)

(52) **U.S. Cl.** **600/345; 600/322; 600/309**

(58) **Field of Classification Search** **600/309, 600/547, 322, 345**

See application file for complete search history.

(56) **References Cited**

U.S. PATENT DOCUMENTS

4,469,593 A *	9/1984	Ishihara et al.	210/96.2
4,484,135 A *	11/1984	Ishihara et al.	324/71.1
4,686,479 A *	8/1987	Young et al.	205/781.5
4,901,725 A	2/1990	Nappholz et al.	
5,174,286 A	12/1992	Chirife	
5,179,946 A	1/1993	Weiss	

FOREIGN PATENT DOCUMENTS

JP 58029450 A 2/1983

(Continued)

OTHER PUBLICATIONS

"International Search Report and Written Opinion for Application No. PCT/US2005/027277, date mailed Nov. 14, 2005", 13 pgs.

(Continued)

Primary Examiner — Charles A Marmor, II

Assistant Examiner — Karen Toth

(74) *Attorney, Agent, or Firm* — Schwegman, Lundberg & Woessner, P.A.

(57) **ABSTRACT**

A technique for determining a patient's hematocrit by an electrical impedance measurement is described. An implantable device may be configured to utilize the technique in order to assess a cardiac patient's fluid status. In order to determine the hematocrit, the electrical impedance of the blood is measured and mapped by a mapping function to a corresponding hematocrit value.

15 Claims, 2 Drawing Sheets

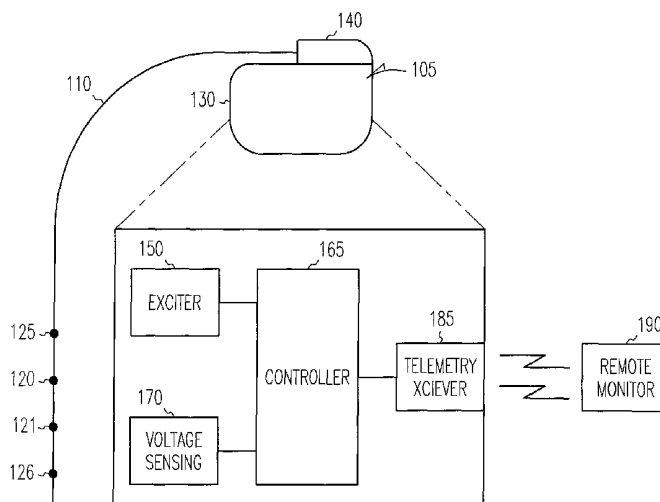

U.S. PATENT DOCUMENTS

6,317,632	B1	11/2001	Krig et al.	
6,463,326	B1	10/2002	Hartley et al.	
6,574,506	B2	6/2003	Kramer et al.	
7,356,366	B2	4/2008	Sweeney et al.	
7,732,210	B2*	6/2010	Conlon et al.	436/8
2002/0002389	A1	1/2002	Bradley et al.	
2002/0107552	A1	8/2002	Krig et al.	
2002/0123768	A1	9/2002	Gilkerson	
2002/0123769	A1	9/2002	Panken et al.	
2003/0069609	A1	4/2003	Thompson	
2003/0096420	A1*	5/2003	Heller	436/63
2003/0105499	A1	6/2003	Hartley et al.	
2003/0114889	A1	6/2003	Huvelle et al.	
2003/0212316	A1*	11/2003	Leiden et al.	600/323
2004/0049237	A1	3/2004	Larson et al.	
2004/0054268	A1*	3/2004	Esenaliev et al.	600/322
2004/0057037	A1	3/2004	Ohishi et al.	
2004/0102908	A1	5/2004	Larson et al.	
2004/0116820	A1	6/2004	Daum et al.	
2006/0025661	A1	2/2006	Sweeney et al.	

FOREIGN PATENT DOCUMENTS

JP	59013947	A	1/1984
JP	59115051	A	7/1984
JP	63133062	A	6/1988
JP	2001500392	A	1/2001
JP	2002099034	A	4/2002
JP	2002177226	A	6/2002
JP	2002522103	A	7/2002
JP	2003501167	A	1/2003
JP	2003280930	A	3/2003
JP	2003527164	A	9/2003
JP	2004097781	A	4/2004
WO	WO-9943385		9/1999
WO	WO-0074775	A1	12/2000
WO	WO-0176479	A1	10/2001
WO	WO-03077759	A1	9/2003
WO	WO-2006017446	A1	2/2006

OTHER PUBLICATIONS

Cha, Kichul, et al., "An electronic method for rapid measurement of haematocrit in blood samples", *Physiological Measurement*, 15 (2), (1994), 129-137.
 Freeberg, S., "Cross-Checking of Transthoracic Impedance and Acceleration Signals", U.S. Appl. No. 10/696,729, filed Oct. 29, 2003.

Kim, J., et al., "Cardiac Cycle Synchronized Sampling of Impedance Signal", U.S. Appl. No. 10/612,388, filed Jul. 2, 2003.
 Krig, David B., "Apparatus and Method for Treating Ventricular Tachyarrhythmias", U.S. Appl. No. 11/073,818, filed Mar. 7, 2005, 61 pgs.
 Larson, Dennis E., et al., "Minute Ventilation Sensor With Automatic High Pass Filter Adjustment", U.S. Appl. No. 10/306,889, filed Nov. 27, 2002, 33 pages.
 Maasrani, M., et al., "Continuous Measurements by Impedance of Haematocrit and Plasma Volume Variations During Dialysis", *Medical & Biological Engineering & Computing*, 35 (3), (May 1997), 167-171.
 Pop, G. A., et al., "Catheter-based Impedance Measurements in the Right Atrium for continuously monitoring Hematocrit and Estimating blood Viscosity Changes; an in vivo Feasibility Study in Swine", *Biosensors and Bioelectronics*, 19 (12), (Jul. 15, 2004), 1685-1693.
 Stahmann, J. E., et al., "Implantable Devices and Methods Using Frequency-Domain Analysis of Thoracic Signal", U.S. Appl. No. 10/612,387, filed Jul. 2, 2003.
 Zhang, Y., et al., "Methods and Apparatuses for Arrhythmia Detection and Classification Using Wireless ECG", U.S. Appl. No. 10/975,166, filed Oct. 28, 2004, 69 Pages.
 "U.S. Appl. No. 10/909,926, Supplemental Notice of Allowability mailed Jan. 30, 2008", 6 pgs.
 "U.S. Appl. No. 10/909,926, Notice of Allowance Mailed Nov. 14, 2007", 7 pgs.
 "European Application Serial No. 05778392.0, Office Action mailed Feb. 6, 2009", 4 pgs.
 "Japanese Application Serial No. 2007-524890, Response filed May 16, 2011 to Non Final Office Action mailed Feb. 14, 2011", 11 pgs.
 "Japanese Application Serial No. 2007-524890, Office Action mailed Feb. 14, 2011", 3 pgs.
 "Japanese Application Serial No. 2007-524890, Notice of Allowance mailed Jun. 14, 2011", 3 pgs.
 Cha, K., et al., "An electronic method for rapid measurement of haematocrit in blood samples", *Physiol Meas.*, 15(2), (May 1994), 129-37.
 Maasrani, M., et al., "Continuous measurements by impedance of haematocrit and plasma volume variations during dialysis", *Med Biol Eng Comput.*, 35(3), (May 1997), 167-71.
 Pop, G. A., et al., "Catheter-based impedance measurements in the right atrium for continuously monitoring hematocrit and estimating blood viscosity changes; an in vivo feasibility study in swine.", *Biosens Bioelectron.*, 19(12), (Jul. 15, 2004), 1685-93.
 * cited by examiner

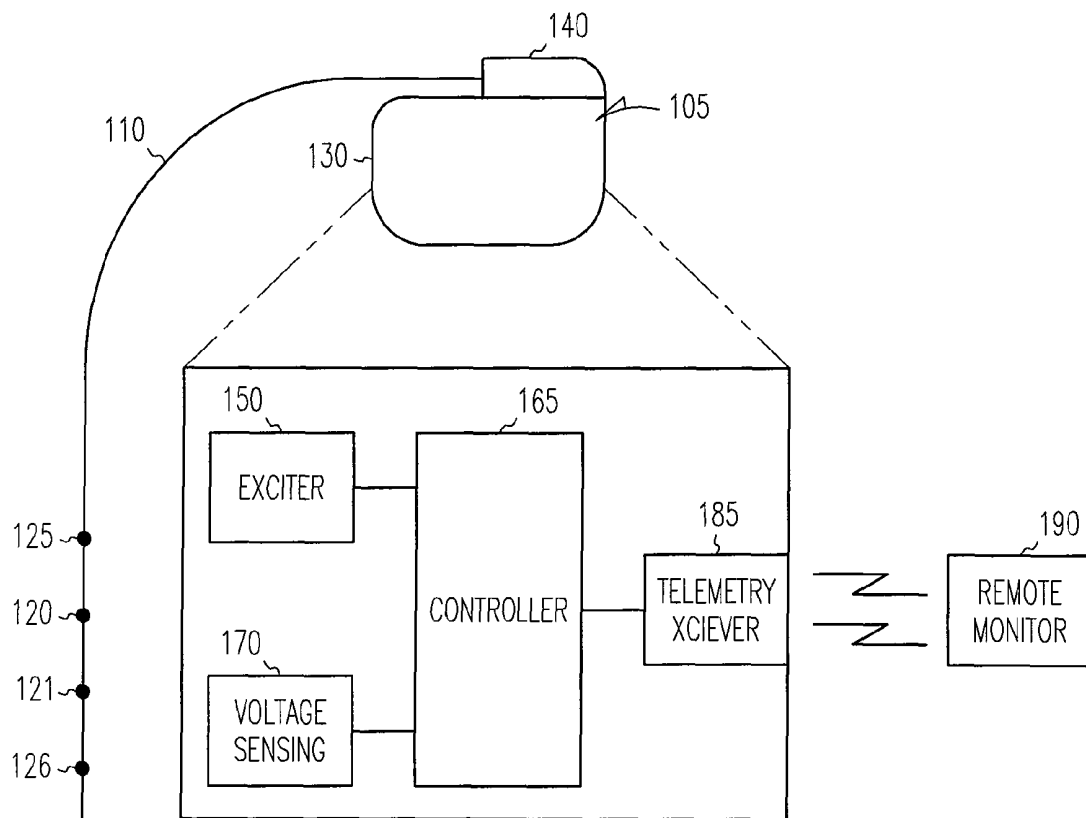

FIG. 1

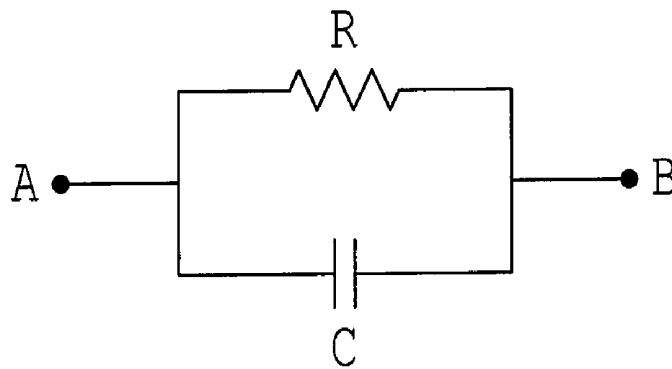

FIG. 2

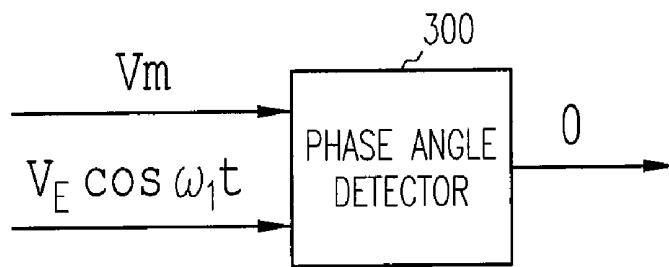

FIG. 3

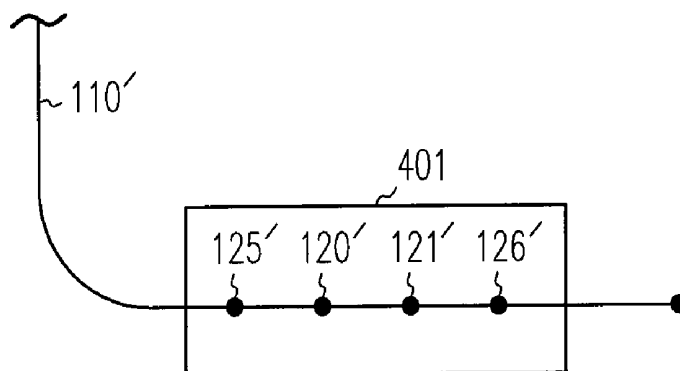

FIG. 4

DEVICE FOR MONITORING FLUID STATUS**CROSS REFERENCE TO RELATED APPLICATION**

This application is a continuation of U.S. application Ser. No. 10/909,926, filed Aug. 2, 2004, now U.S. Pat. No. 7,356,366, the specification of which is herein incorporated by reference.

FIELD OF THE INVENTION

This invention pertains to methods and apparatus for medical monitoring.

BACKGROUND

Cardiac failure refers to a condition in which the heart fails to pump enough blood to satisfy the needs of the body. It is usually due to some damage to the heart itself, such as from a myocardial infarction or heart attack. When heart failure occurs acutely, autonomic circulatory reflexes are activated that both increase the contractility of the heart and constrict the vasculature as the body tries to defend against the drop in blood pressure. Venous constriction, along with the reduction in the heart's ability to pump blood out of the venous and pulmonary systems (so-called backward failure), causes an increase in the diastolic filling pressure of the ventricles. This increase in preload (i.e., the degree to which the ventricles are stretched by the volume of blood in the ventricles at the end of diastole) causes an increase in stroke volume during systole, a phenomena known as the Frank-Starling principle. If the heart failure is not too severe, this compensation is enough to sustain the patient at a reduced activity level. When moderate heart failure persists, other compensatory mechanisms come into play that characterize the chronic stage of heart failure. The most important of these is the depressing effect of a low cardiac output on renal function. The increased fluid retention by the kidneys then results in an increased blood volume and further increased venous return to the heart. A state of compensated heart failure results when the factors that cause increased diastolic filling pressure are able to maintain cardiac output at a normal level even while the pumping ability of the heart is compromised.

Compensated heart failure, however, is a precarious state. If cardiac function worsens or increased cardiac output is required due to increased activity or illness, the compensation may not be able to maintain cardiac output at a level sufficient to maintain normal renal function. Fluid then continues to be retained, causing the progressive peripheral and pulmonary edema that characterizes overt congestive heart failure. Diastolic filling pressure becomes further elevated which causes the heart to become so dilated and edematous that its pumping function deteriorates even more. This condition, in which the heart failure continues to worsen, is decompensated heart failure. It can be detected clinically, principally from the resulting pulmonary congestion and dyspnea, and all clinicians know that it can lead to rapid death unless appropriate therapy is instituted. It would be advantageous if there were a convenient means by which the fluid status of a patient could be monitored in order to detect the physiologic changes leading to decompensated heart failure at an early stage before clinical symptoms become apparent.

BRIEF DESCRIPTION OF THE DRAWINGS

FIG. 1 illustrates an exemplary implantable device.
FIG. 2 is a circuit model of the blood impedance.

FIG. 3 illustrates a phase angle detector for processing the voltage difference signal.

FIG. 4 shows a modified lead for determining plasma impedance.

DETAILED DESCRIPTION

Decompensated heart failure is primarily a result of the heart failing to pump sufficient blood for the kidneys to function adequately and maintain fluid balance. When cardiac output falls, renal perfusion decreases which results in reduced glomerular filtration and reduced urine output. The decreased blood flow to the kidneys also activates the rennin-angiotensin system which further reduces renal perfusion and promotes the reabsorption of water and salt from the renal tubules. In the latter stages of this process, angiotensin stimulates secretion of aldosterone which causes a further increase in the reabsorption of sodium. The increase in sodium reabsorption raises the osmolarity of the blood which then elicits secretion of vasopressin and increased tubular reabsorption of water. Excess fluid retention brought about by renal compensation for heart failure has a diluting effect on the blood. Thus, one indication of deterioration in a heart failure patient's fluid status is a decrease in the patient's hematocrit, where the hematocrit is defined as the percentage of red blood cells in the blood. Described herein is an implantable device for monitoring a patient's fluid status by determining the concentration of cellular material in the blood from an electrical measurement.

The blood consists mainly of red blood cells suspended in non-cellular plasma, where the plasma is a solution of proteins and electrolytes, principally sodium and chloride. The blood is therefore a volume conductor which can be characterized electrically by its conductivity and permittivity. The conductivity and permittivity (or dielectric constant) of the medium determine the current density and polarization, respectively, which result if a known electric field is impressed in the medium. If charge is injected into the blood, the blood presents an impedance to the injected current which is a function of its conductivity and permittivity. A signal proportional to this impedance may be produced by impressing a known current field in a volume of blood surrounding two points and then measuring the voltage difference between the points. The measured voltage difference will then vary proportionately with changes in blood impedance. Since cellular material is a poorer conductor than an electrolyte solution, the impedance of the blood varies with the hematocrit so that as the concentration of red blood cells decreases, the impedance decreases. A measurement of the electrical impedance of the blood is therefore reflective of the hematocrit. Different embodiments of this technique are described below after a description of an exemplary implantable device.

1. Exemplary Implantable Device

The technique for monitoring fluid status as described herein may be implemented in an implantable device configured to perform monitoring only or in a cardiac rhythm management device configured to also deliver cardiac therapies such as bradycardia pacing, cardioversion/defibrillation therapy, or cardiac resynchronization therapy. The latter may be particularly useful since heart failure patients who need fluid status monitoring may also benefit from resynchronization pacing which improves cardiac function by causing the ventricles to contract in more coordinated manner. Examples of such devices are described in U.S. Pat. Nos. 6,574,506 and 7,092,757, assigned to Cardiac Pacemakers, Inc., and hereby incorporated by reference in their entirety.

Implantable cardiac rhythm management devices such as pacemakers and cardioverter/defibrillators are battery-powered devices which are usually implanted subcutaneously on the patient's chest and connected to electrodes by leads threaded through the vessels of the upper venous system into the heart. FIG. 1 illustrates an implantable device **105** and a multi-conductor lead **110** having electrodes incorporated therein for performing the electrical measurements needed to assess fluid status. Device **105** may be, for example, a pacemaker capable of delivering bradycardia and/or antitachycardia pacing, an implantable cardioverter/defibrillator, a combination pacemaker/defibrillator, a drug delivery device, or a fluid status monitoring-only device. The device may therefore have one or more other leads with electrodes for disposition in the right atrium or ventricle or in a cardiac vein for sensing cardiac activity and/or delivering electrical stimulation to the heart. The lead **110** is adapted to be intra-vascularly disposed such as in an accessible location of the venous system or within a heart chamber. The device **105** includes a hermetically sealed housing **130**, formed from a conductive metal, such as titanium. Housing **130** (also referred to as a "case" or "can") may be substantially covered over its entire surface by a suitable insulator, such as silicone rubber, except for a window that forms a third electrode, referred to as a "case" or "can" electrode. A header **140**, which may be formed of an insulating material, is mounted on housing **130** for receiving leads such as lead **110** or other leads used for cardiac sensing or stimulation. Contained within the housing **130** is the electronic circuitry for providing fluid status monitoring functionality to the device as described herein. In the case of a pacemaker or cardioverter/defibrillator, the housing would also contain circuitry for sensing and stimulating the heart.

As shown in FIG. 1, the device **105** includes a controller **165** which may be made up of discrete circuit elements but is preferably a processing element such as a microprocessor together with associated memory for program and data storage. The controller is programmed to perform the algorithms for monitoring fluid status which are described below. Interfaced to the controller **165** is an exciter **150** for delivering excitation current between excitation current electrodes **125** and **126** which are incorporated into the lead **110**. The exciter **150** delivers the excitation current in accordance with parameters dictated by the controller which may include the current frequency, current amplitude, and the type of current waveform (e.g., square-wave, sinusoidal). In an example embodiment, the exciter includes a voltage controlled constant current source which is driven by a voltage signal V_E to produce an excitation current waveform I_E . Also incorporated into the lead **110** are voltage sense electrodes **120** and **121** which are situated between the excitation current electrodes and connected to voltage sensing circuitry **170**. Voltage sensing circuitry **170** is interfaced to the controller and includes amplification, filtering, and analog-to-digital conversion circuitry for processing the voltage difference signal produced by the electrodes **120** and **121**.

Also interfaced to the controller **165** is a telemetry transmitter **185** capable of communicating with an external programmer or remote monitoring device **190**. An external programmer wirelessly communicates with the device **105** and enables a clinician to receive data and modify the programming of the controller. The remote monitoring device **190** similarly communicates with the device **105** and is further interfaced to a patient management network (e.g., via an internet connection) which allows clinical personnel at remote locations to receive data from the device.

2. Estimation of Hematocrit from Impedance Measurement

As noted above, the electrical impedance of the blood varies with the hematocrit. A signal proportional to the impedance of the blood may be produced by impressing a current field from a constant current source between two electrodes immersed in the blood and then measuring the voltage difference therebetween. In the device illustrated in FIG. 1, the exciter delivers a predetermined amount of current between excitation current electrodes **125** and **126** of lead **110** with voltage sense electrodes **120** and **121** located between the excitation current electrodes **125** and **126**. (Other embodiments may utilize electrodes incorporated into different leads or may use the can as an electrode.) The voltage difference measured between the voltage sense electrodes **120** and **121** is thus proportional to the electrical impedance of the blood. A particular measured voltage difference V_m may be mapped to an estimated hematocrit value Hct_{est} by a mapping function F :

$$Hct_{est} = F(V_m)$$

The mapping function F relates particular values of the voltage measurement to corresponding hematocrit values and, in general, will depend upon the particular current field produced by the excitation electrodes, the physical locations of the voltage sense electrodes, and the volume of blood in which the voltage sense electrodes are immersed. The mapping function may therefore be empirically determined under actual or simulated conditions and expressed as either a continuous or discrete function, the latter being implemented, for example, as a look-up table. (As will be described below, such an empirically determined mapping function may also be constructed to map other measured or derived parameters to an estimated hematocrit value.) Also, the physical configuration of the voltage sense and excitation current electrodes can be made so as to minimize changes in the voltage measurement signal V_m due to changes in the impedance of the tissues other than blood surrounding the electrodes. If the voltage sense electrodes are spaced apart closely enough, the impedance between them will be almost completely due to the volume of blood surrounding the electrodes. Similarly, if the excitation current electrodes closely straddle the voltage sense electrodes, the current field produced by them will not vary appreciably with changes in the impedance of the surrounding tissues.

FIG. 2 shows two arbitrary points labeled A and B in a volume of blood. The impedance to a current flow between the two points can be modeled as an equivalent resistance R proportional to the blood's conductivity in parallel with an equivalent capacitance C proportional to the blood's permittivity. The impedance Z between the two points A and B in the blood is thus:

$$Z = R / (1 + j\omega CR)$$

where ω is the frequency of the applied excitation current. Other models of the blood impedance could also be used such as a resistance representing plasma conductivity in parallel with resistance in series with a capacitance representing both the conductivity and permittivity of the red blood cells. The analysis is similar, however, to that set forth below.

Whatever the physical positions of points A and B in FIG. 2 and the value of Z , the voltage measurement signal V_m derived as the potential difference between the voltage sense electrodes will vary proportionately with any changes in Z which occur due to changes in the blood's conductivity and/or permittivity. The voltage measurement signal can therefore be regarded as a virtual impedance measurement Z_m . (The impedance Z_m would be the impedance between two points in a volume of blood which are spaced apart at a distance such that an injected current of unit amplitude between the points pro-

duces a voltage difference equal to V_m). The virtual impedance Z_m is made up of a resistive component R_m and a reactive or capacitive component $1/\omega C_m$:

$$Z_m = R_m / (1 + j\omega C_m R_m)$$

Increasing the concentration of red blood cells in the blood increases R_m because cellular material is a poorer conductor than the solution of electrolytes which make up the plasma. The red blood cells also permit separations of charges to exist and therefore constitute a distributed capacitance (i.e., permittivity) which increases as the concentration of red blood cells increases.

Although both R_m and C_m increase as the concentration of red blood cells increases, the capacitive component of the impedance is small relative to the resistive component so that the overall impedance increases with increasing hematocrit. Except at very high excitation current frequencies, therefore, an increased hematocrit produces an increase in the magnitude of Z_m , where the magnitude of Z_m is defined as:

$$|Z_m| = R_m / (1 + \omega^2 (C_m R_m)^2)^{1/2}$$

In one embodiment, the mapping function F is constructed in order to map the magnitude of the blood impedance to an estimated hematocrit value. The amplitude of the voltage measurement signal V_m , designated as $|V_m|$, is equal to $|Z_m|$ and may be mapped to a hematocrit value by a mapping function F_Z :

$$Hct_{est} = F_Z(|Z_m|)$$

Since the magnitude of the blood impedance $|Z|$ is dependent upon the excitation current frequency, the mapping function F_Z is either defined only at a selected excitation current frequency or is made frequency dependent. In the latter case, the mapping function F_Z takes into account the fact that the reactive portion of the impedance Z_m increases with increasing excitation current frequency which tends to decrease the total impedance.

As noted above, the capacitance C_m is due almost entirely to the presence of red blood cells in the blood. In another embodiment, a mapping function F_C is constructed which maps values of the capacitance of the blood C_m to a hematocrit value:

$$Hct_{est} = F_C(C_m)$$

The value of C_m may be derived from measurements of the voltage difference V_m . When the excitation current is applied at DC or at relatively low frequencies, V_m reflects only the resistive portion of the impedance so that V_m is then equal to R_m . Once R_m is found in this manner, C_m may be derived by detecting the phase angle between the excitation current waveform and the voltage measurement signal waveform at an excitation current frequency ω_1 where the capacitive component of the impedance Z_m is evident. FIG. 3 illustrates this technique where the voltage measurement signal V_m and a signal $V_E \cos \omega_1 t$ used to drive the exciter **150** and which is in phase with the excitation current are input to a phase angle detector **300**. The phase angle detector may either be implemented as discrete hardware or as code executed by the controller. The output of the phase angle detector is a phase angle Φ_1 which may be used to derive C_m as follows:

$$C_m = R_m \omega_1 \tan \Phi_1$$

Alternatively, the magnitude of Z_m may be measured at the excitation current frequency of ω_1 with the value of C_m then being calculated from the impedance formula as:

$$C_m = ((R_m / |Z_m|)^2 - 1)^{1/2} / \omega_1 R_m$$

where the magnitude $|Z_m|$ is measured as the amplitude of V_m at the excitation current frequency of ω_1 .

In addition to being a function of hematocrit, the blood impedance Z_m also depends upon the electrolyte concentration in the blood. The electrolytes in the blood are made up primarily of sodium and chloride with smaller amounts of other salts and charged proteins. The concentration of these electrolytes in the plasma may vary in an individual patient which would then affect the measured impedance of the blood. In order to take this into account, a mapping function may be constructed which maps both a measured impedance Z_m (e.g., the amplitude of the voltage difference signal V_m) and a measured electrolyte concentration E to an estimated hematocrit value:

$$Hct_{est} = F_{ZE}(Z_m, E)$$

In order to determine the electrolyte concentration E for use with the F_{ZE} mapping function, the resistivity of the blood plasma R_p is determined using voltage sense electrodes which are immersed in a sample of the patient's plasma. FIG. 4 illustrates a modified lead **110'** which may be used for this purpose where the voltage sense electrodes **120'** and **121'** are surrounded by a sleeve **401** made of a material (e.g., Gore-Tex) which is impermeable to blood cells but permeable to the constituents of blood plasma. The excitation current electrodes **125'** and **126'** may also be enclosed within the sleeve **401**. The electrodes **120'**, **121'**, **125'**, and **126'** are connected to the device **105** in manner similar to that of their unprimed counterparts illustrated in FIG. 1. An impedance measurement between the voltage sense electrodes **120'** and **121'** is performed as described above to derive a plasma resistivity value R_p which can then be mapped to an estimated electrolyte concentration E by an empirically determined mapping function F_E :

$$E = F_E(R_p)$$

The estimated electrolyte concentration is then used in conjunction with the impedance measurement of whole blood to estimate the hematocrit using the F_{ZE} mapping function as described above. In another modification, a temperature sensor may be included in an intravascular lead and employed by the implantable device to measure the temperature of the blood, which temperature measurement may then be incorporated into the mapping function for mapping an impedance measurement to an estimated hematocrit value.

The estimated hematocrit value Hct_{est} may be calculated by the device at programmed intervals or upon receiving a command from an external device such as an external programmer. In the former case, changes in fluid status as determined by the hematocrit may be trended over time and stored for later analysis by a clinician. The estimated hematocrit may also be compared with a specified limit range so that an alarm flag is set internally by the device if the hematocrit is above or below the limit range, indicating fluid loss or fluid retention, respectively. Setting the alarm flag may also result in the implantable device transmitting an alarm message to a remote monitoring device which may be further communicated to clinical personnel over a patient management network.

Besides being used to estimate hematocrit, the measurement of blood impedance may also be used to adjust other impedance sensing modalities which an implantable device may possess. For example, an implantable device may utilize impedance measurements to calculate minute ventilation or cardiac stroke volume. Such calculations may be modified to take into account the impedance of the blood measured as described above.

Although the invention has been described in conjunction with the foregoing specific embodiments, many alternatives, variations, and modifications will be apparent to those of ordinary skill in the art. Such alternatives, variations, and modifications are intended to fall within the scope of the following appended claims. 5

What is claimed is:

1. A device, comprising:
 - an exciter for outputting an excitation current waveform and impressing a current field between a pair of excitation current electrodes; 10
 - voltage sensing circuitry for sensing a voltage difference signal between a pair of voltage sense electrodes disposed in a patient's blood and in the current field; 15
 - means for measuring an electrolyte concentration in the patient's blood;
 - a controller interfaced to the voltage sensing circuitry which is programmed to estimate the patient's hematocrit from the voltage difference signal and the measured electrolyte concentration; and, 20
 - wherein the controller is programmed to estimate the patient's hematocrit with a mapping function which maps a capacitance value derived from the voltage difference signal to a hematocrit value and programmed to derive a capacitance value from the voltage difference signal by deriving a resistance value from the voltage difference signal at a first excitation frequency and measuring a phase angle between the excitation current waveform and the voltage difference signal at a second excitation frequency. 25
2. The device of claim 1 further comprising a lead which incorporates the excitation current electrodes and the voltage sense electrodes, wherein the voltage sense electrodes are located between the excitation current electrodes.
3. The device of claim 1 wherein the controller is programmed to estimate the patient's hematocrit with a mapping function which maps the amplitude of the voltage difference signal to a hematocrit value. 35
4. The device of claim 1 further comprising means for measuring a resistivity of the patient's plasma and wherein the controller is programmed to estimate the patient's hematocrit with a mapping function which maps the amplitude of the voltage difference signal and the resistivity of the patient's plasma to a hematocrit value. 40
5. The device of claim 1 wherein the controller is programmed to periodically estimate the patient's hematocrit which is stored and trended over time. 45
6. The device of claim 1 wherein the controller is programmed to compare the estimated hematocrit value with a specified limit range and set an alarm flag if the estimated hematocrit value is out of the specified limit range. 50
7. The device of claim 1 wherein the means for measuring the electrolyte concentration in the patient's blood comprises:
 - a sleeve made of a material that is impermeable to blood cells but permeable to the constituents of blood plasma; 55
 - and,
 - excitation current electrodes and voltage sense electrodes disposed within the sleeve for measuring the resistivity of the plasma within the sleeve.
8. A method for monitoring the fluid status of a patient, 60 comprising:
 - outputting an excitation current waveform and impressing a current field between a pair of excitation current electrodes;
 - sensing a voltage difference signal between a pair of voltage sense electrodes disposed in the patient's blood and in the current field; 65

measuring an electrolyte concentration in the patient's blood;

estimating the patient's hematocrit from the voltage difference signal and the measured electrolyte concentration; and,

estimating the patient's hematocrit with a mapping function which maps a capacitance value derived from the voltage difference signal to a hematocrit value and deriving a capacitance value from the voltage difference signal by deriving a resistance value from the voltage difference signal at a first excitation frequency and measuring a phase angle between the excitation current waveform and the voltage difference signal at a second excitation frequency.

9. The method of claim 8 wherein the voltage sense electrodes are located between the excitation current electrodes in a single lead.

10. The method of claim 8 further comprising estimating the patient's hematocrit with a mapping function which maps the amplitude of the voltage difference signal to a hematocrit value.

11. The method of claim 8 further comprising measuring a resistivity of the patient's plasma and estimating the patient's hematocrit with a mapping function which maps the amplitude of the voltage difference signal and the resistivity of the patient's plasma to a hematocrit value.

12. The method of claim 8 further comprising periodically estimating the patient's hematocrit and trending the estimated hematocrit values over time. 30

13. The method of claim 8 further comprising comparing the estimated hematocrit value with a specified limit range and setting an alarm flag if the estimated hematocrit value is out of the specified limit range.

14. The method of claim 13 wherein the electrolyte concentration in the patient's blood is measured by:

- containing a sample of the patient's blood within a sleeve made of a material that is impermeable to blood cells but permeable to the constituents of blood plasma; and,
- measuring the resistivity of the plasma within the sleeve using excitation current electrodes and voltage sense electrodes disposed within the sleeve.

15. A device, comprising:

- an exciter for outputting an excitation current waveform and impressing a current field between a pair of excitation current electrodes;

- voltage sensing circuitry for sensing a voltage difference signal between a pair of voltage sense electrodes disposed in a patient's blood and in the current field;
- means for measuring the electrolyte concentration in the patient's blood;

- a controller interfaced to the voltage sensing circuitry which is programmed to estimate the patient's hematocrit from the voltage difference signal and the measured electrolyte concentration; and,

- wherein the controller is programmed to estimate the patient's hematocrit with a mapping function which maps a capacitance value derived from the voltage difference signal to a hematocrit value and programmed to derive a capacitance value from the voltage difference signal by deriving a resistance value from the voltage difference signal at a first excitation frequency and measuring the amplitude of the voltage difference signal at a second excitation frequency.

专利名称(译)	用于监测流体状态的装置		
公开(公告)号	US8103326	公开(公告)日	2012-01-24
申请号	US12/098644	申请日	2008-04-07
[标]申请(专利权)人(译)	心脏起搏器股份公司		
申请(专利权)人(译)	心脏起搏器, INC.		
当前申请(专利权)人(译)	心脏起搏器, INC.		
[标]发明人	SWEENEY ROBERT J SPINELLI JULIO C SALO RODNEY W		
发明人	SWEENEY, ROBERT J. SPINELLI, JULIO C. SALO, RODNEY W.		
IPC分类号	A61B5/00		
CPC分类号	A61B5/053 A61B5/0538 A61B5/14535 A61N1/36521		
其他公开文献	US20080188730A1		
外部链接	Espacenet USPTO		

摘要(译)

描述了一种通过电阻抗测量来确定患者的血细胞比容的技术。可植入设备可以被配置为利用该技术以评估心脏病患者的流体状态。为了确定血细胞比容, 测量血液的电阻抗并通过映射函数将其映射到相应的血细胞比容值。

