



US 20130303887A1

(19) **United States**
(12) **Patent Application Publication**
Holsing et al.

(10) **Pub. No.: US 2013/0303887 A1**
(43) **Pub. Date: Nov. 14, 2013**

(54) **APPARATUS AND METHOD FOR FOUR DIMENSIONAL SOFT TISSUE NAVIGATION**

A61B 8/08 (2006.01)
A61M 25/09 (2006.01)
A61B 8/12 (2006.01)
A61B 5/00 (2006.01)
A61B 5/06 (2006.01)
A61B 1/00 (2006.01)

(75) Inventors: **Troy L. Holsing**, Golden, CO (US);
Mark Hunter, St. Louis, MO (US);
Christopher Lee, St. Louis, MO (US);
Marc Wennogle, Centennial, CO (US)

(52) **U.S. Cl.**

(73) Assignee: **VERAN MEDICAL TECHNOLOGIES, INC.**, St. Louis, MO (US)

CPC *A61B 1/2676* (2013.01); *A61B 5/061* (2013.01); *A61B 1/04* (2013.01); *A61B 1/0005* (2013.01); *A61B 1/00009* (2013.01); *A61M 25/09* (2013.01); *A61B 1/00094* (2013.01); *A61B 8/12* (2013.01); *A61B 5/0066* (2013.01); *A61B 8/0841* (2013.01); *A61B 5/065* (2013.01)
USPC **600/424**; 600/109; 600/585

(21) Appl. No.: **13/817,730**

(22) PCT Filed: **Aug. 22, 2011**

(86) PCT No.: **PCT/US11/48669**

(57) **ABSTRACT**

§ 371 (c)(1),
(2), (4) Date: **Jul. 25, 2013**

Related U.S. Application Data

(60) Provisional application No. 61/375,439, filed on Aug. 20, 2010, provisional application No. 61/375,533, filed on Aug. 20, 2010, provisional application No. 61/375,523, filed on Aug. 20, 2010, provisional application No. 61/375,484, filed on Aug. 20, 2010.

Publication Classification

(51) **Int. Cl.**
A61B 1/267 (2006.01)
A61B 1/04 (2006.01)

A surgical instrument navigation system is provided that visually simulates a virtual volumetric scene of a body cavity of a patient from a point of view of a surgical instrument residing in the cavity of the patient. The surgical instrument navigation system includes: a surgical instrument; an imaging device which is operable to capture scan data representative of an internal region of interest within a given patient; a tracking subsystem that employs electro-magnetic sensing to capture in real-time position data indicative of the position of the surgical instrument; a data processor which is operable to render a volumetric, perspective image of the internal region of interest from a point of view of the surgical instrument; and a display which is operable to display the volumetric perspective image of the patient.

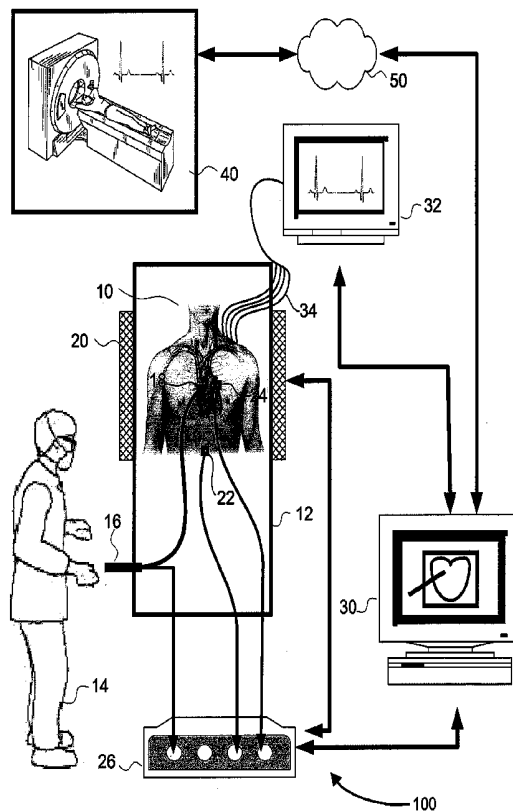

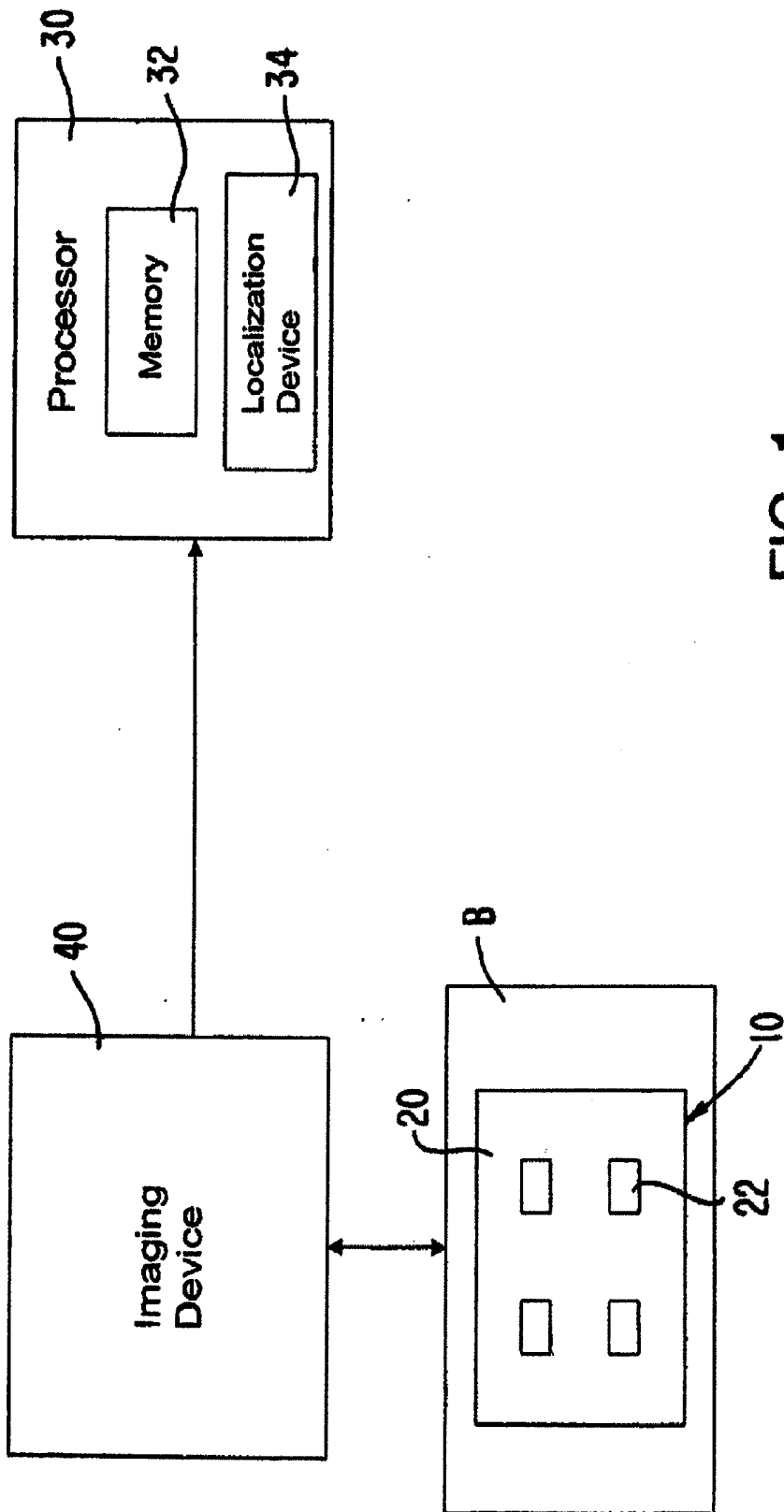

FIG. 1

FIG. 2

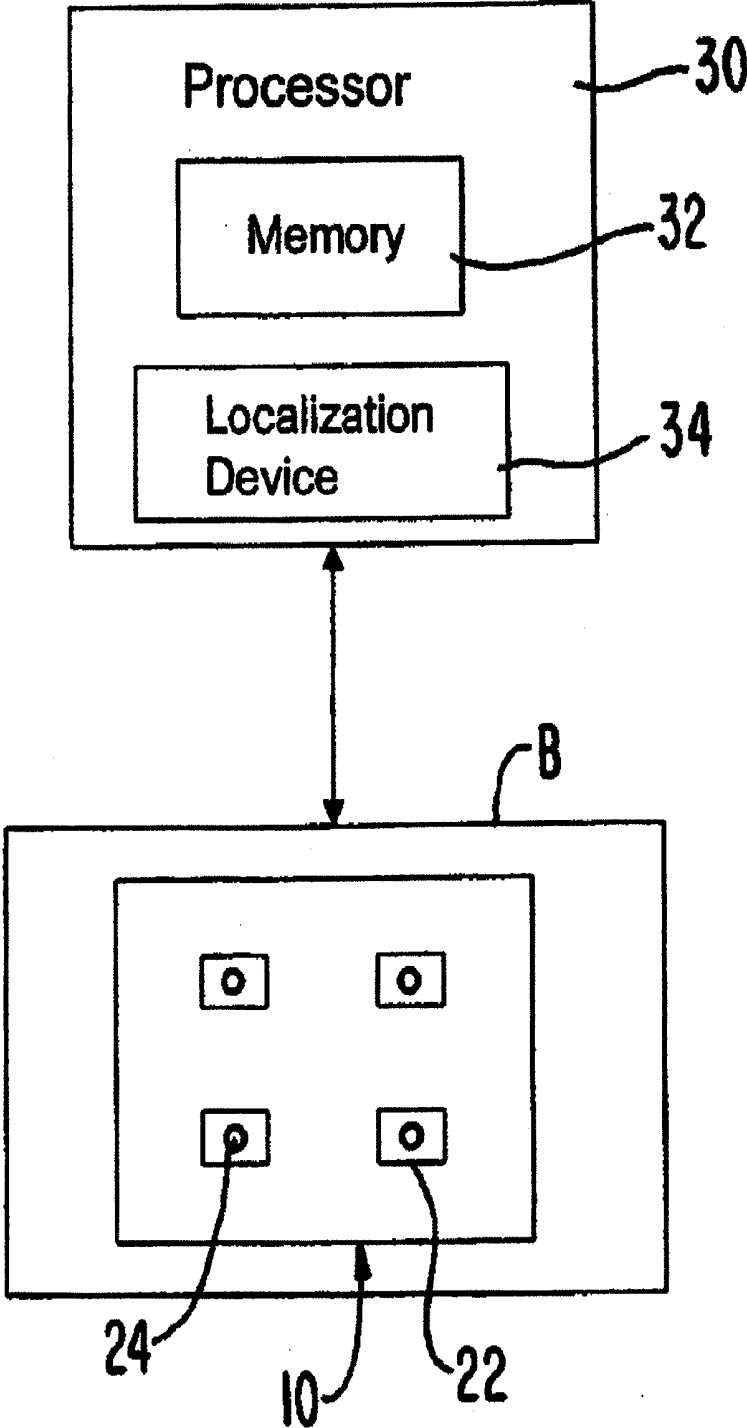

FIG. 3

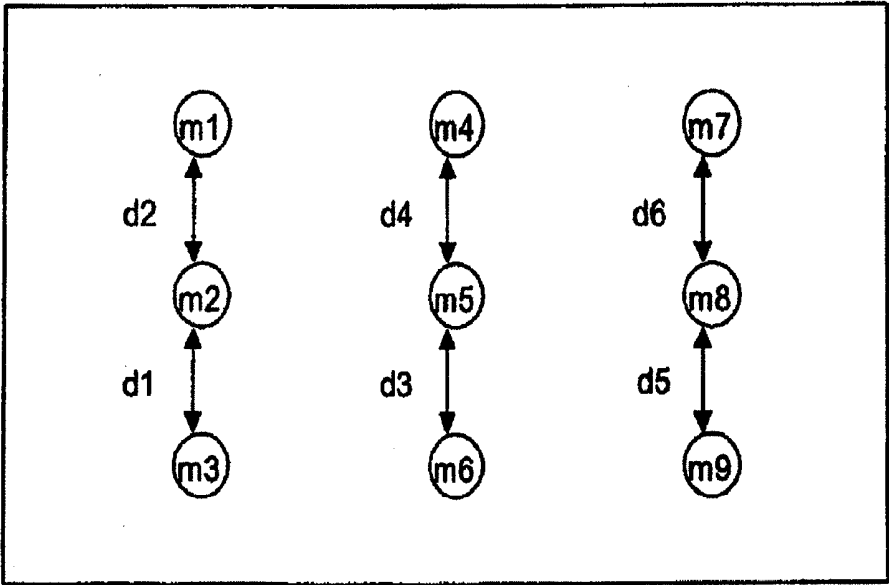

FIG. 4A

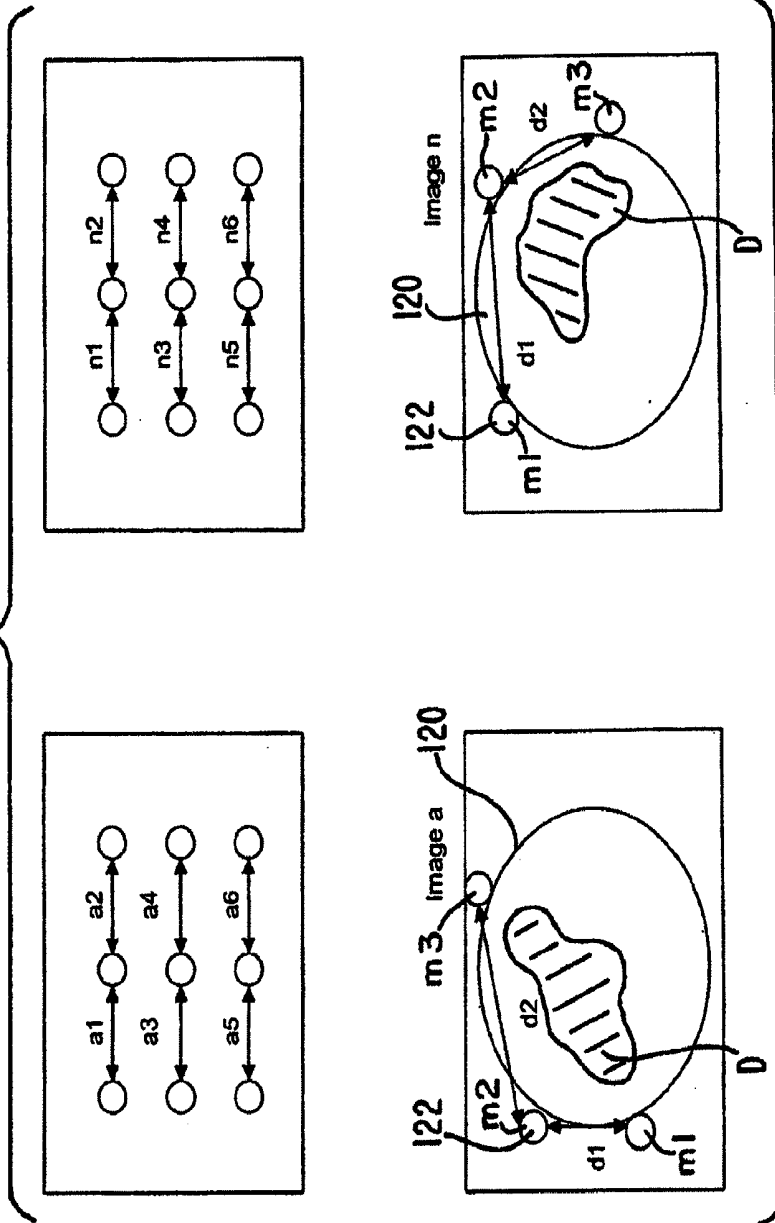

FIG. 4B

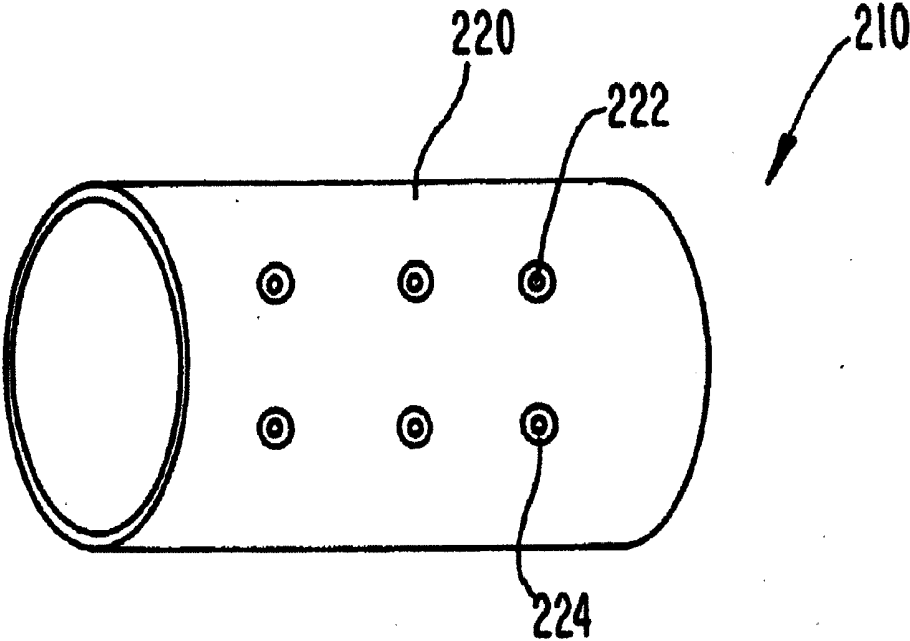

FIG. 5

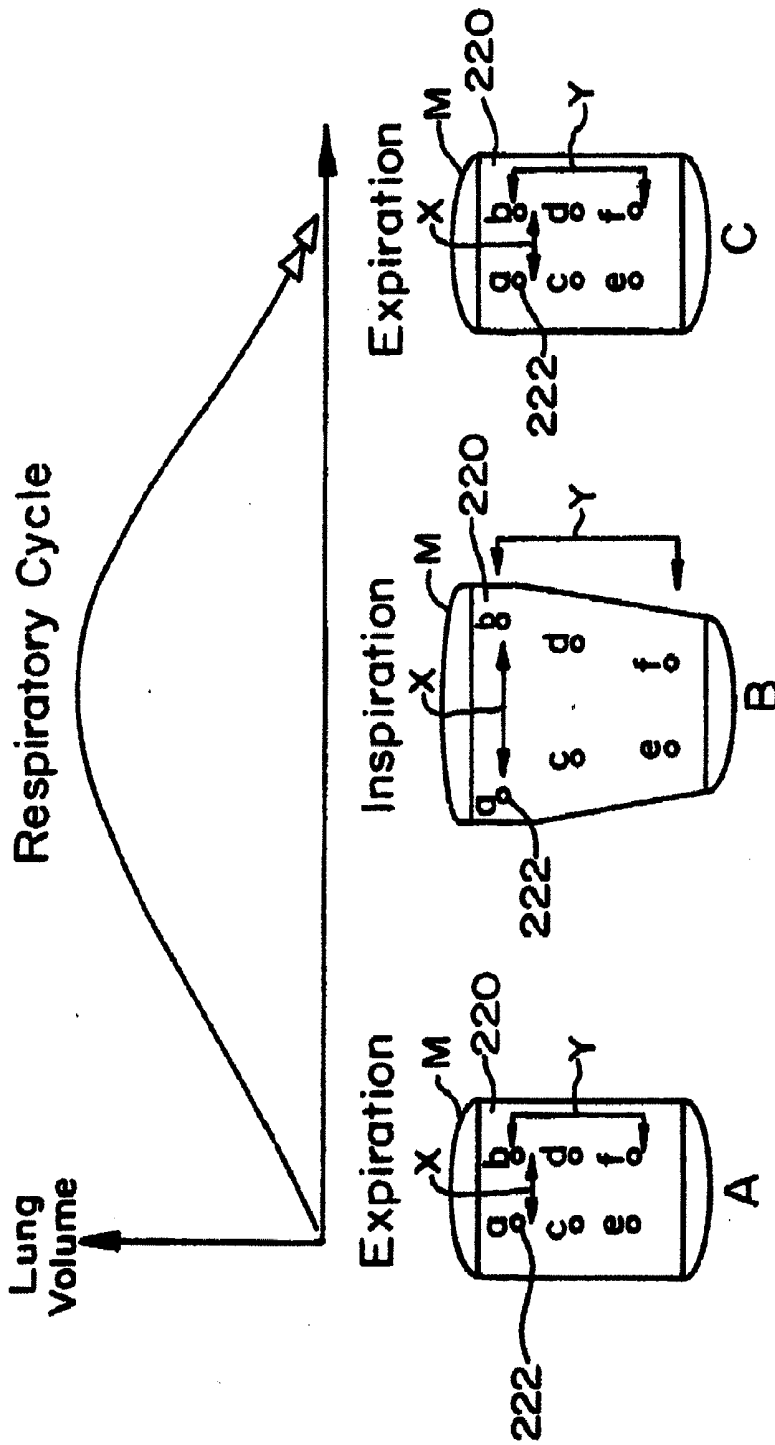
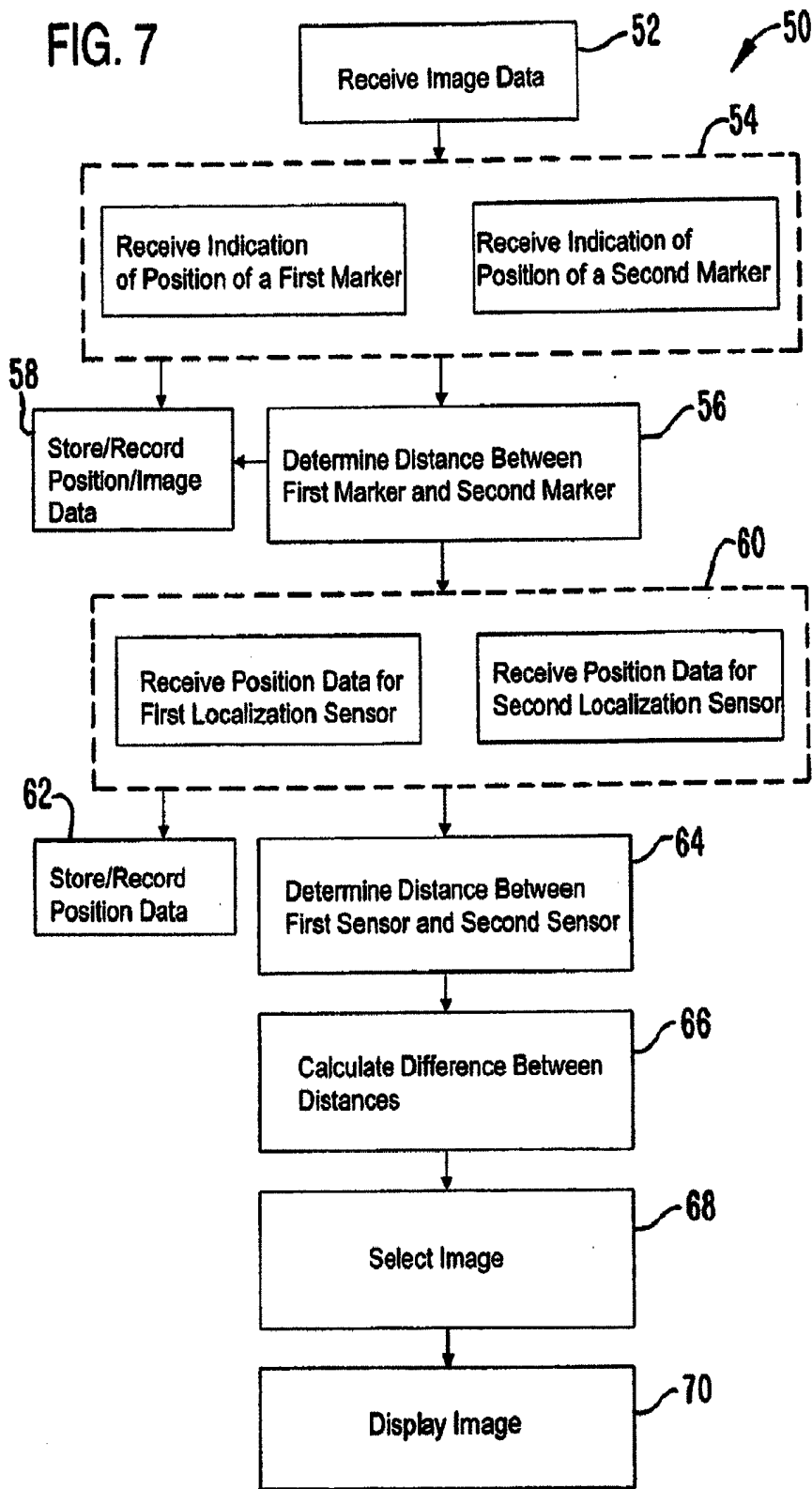

FIG. 6

FIG. 7



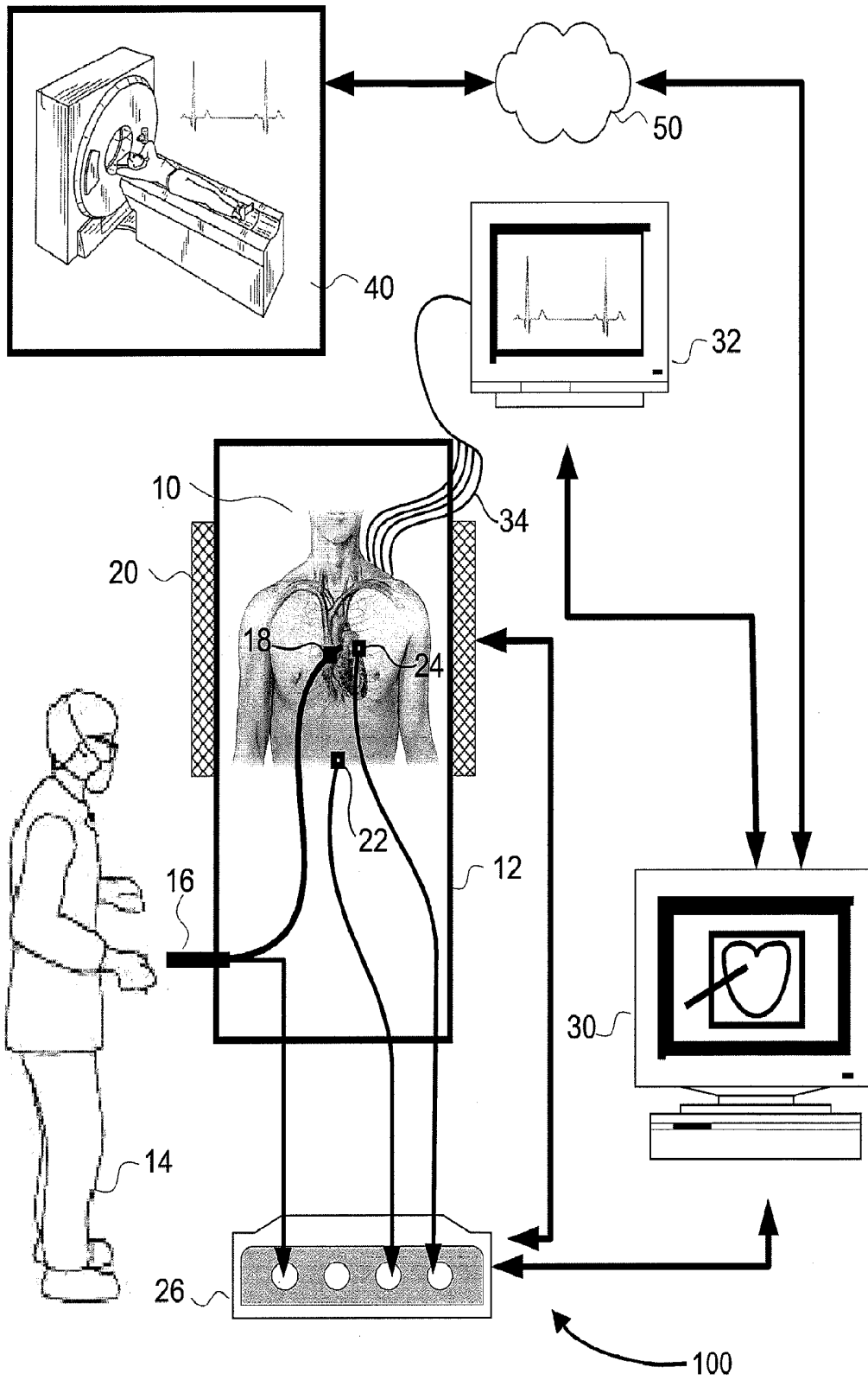

FIG. 8

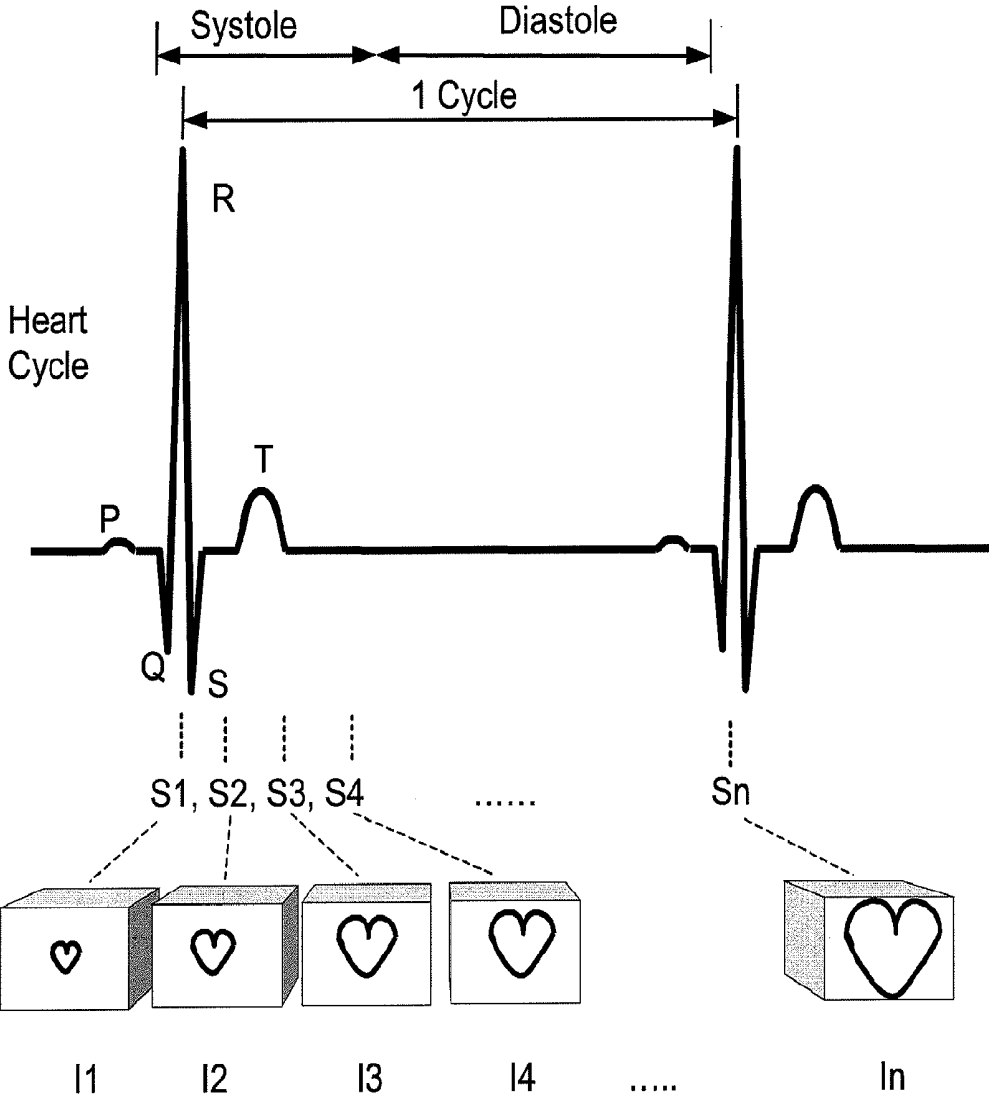

FIG. 9

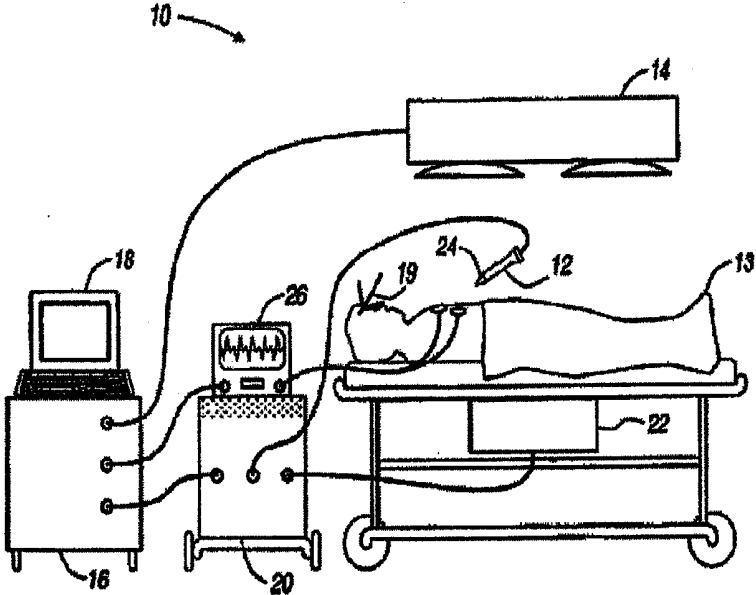

Figure 10

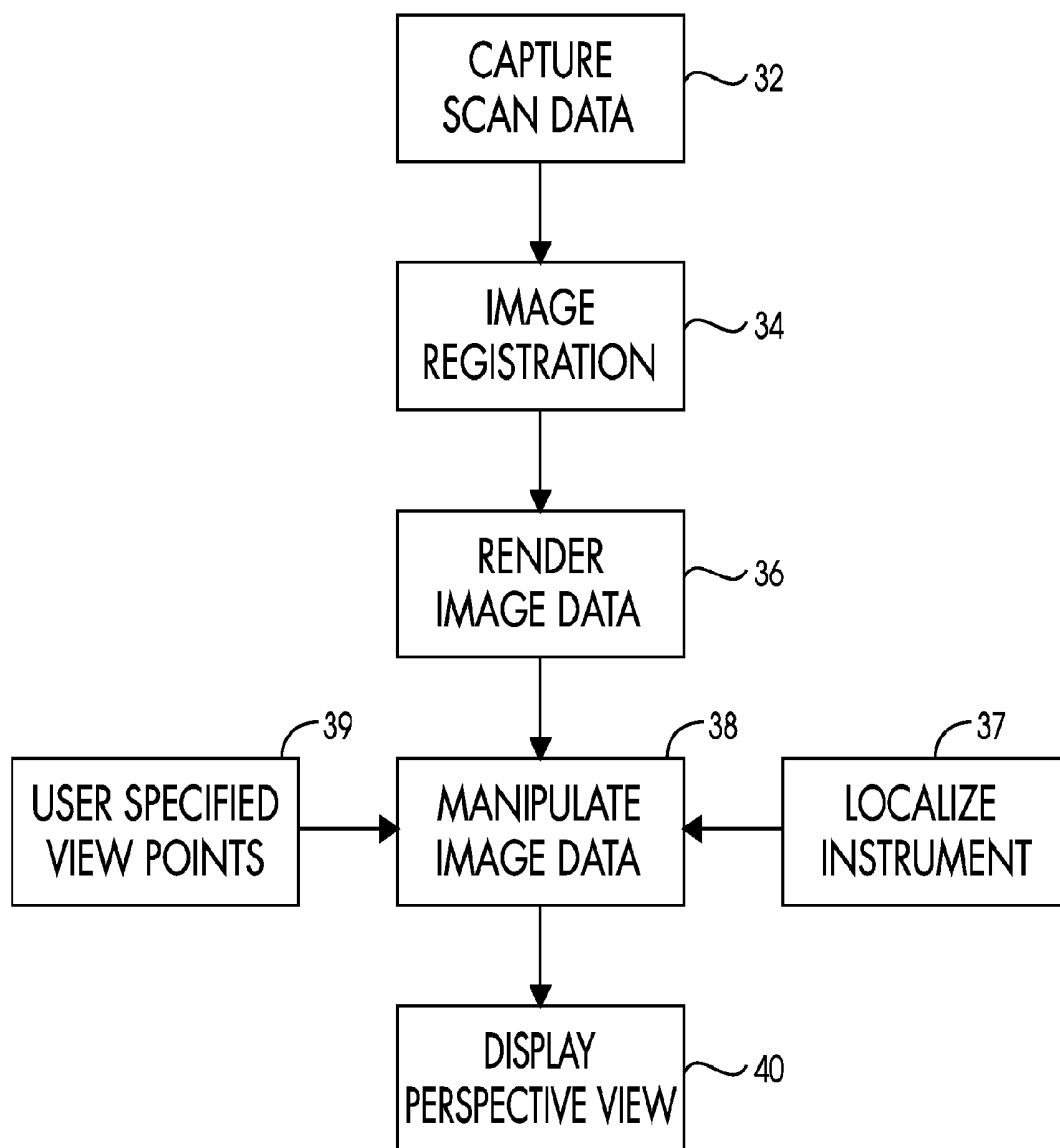

FIG 11

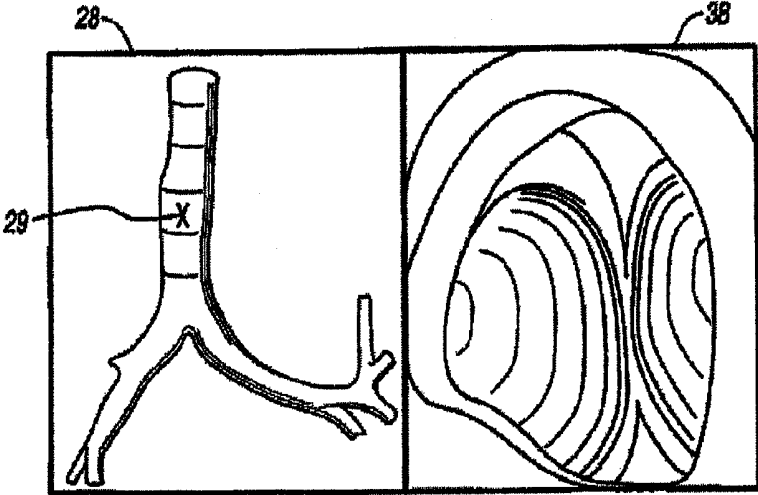

Figure 12

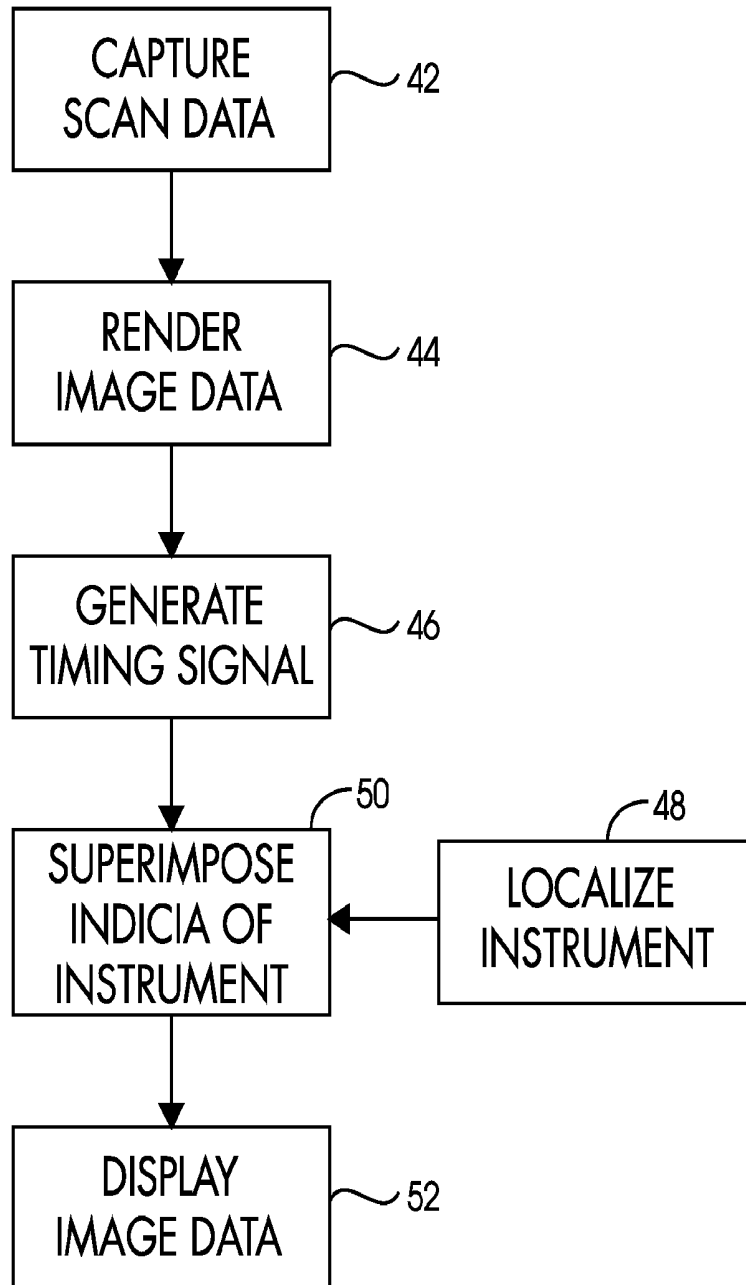

FIG 13

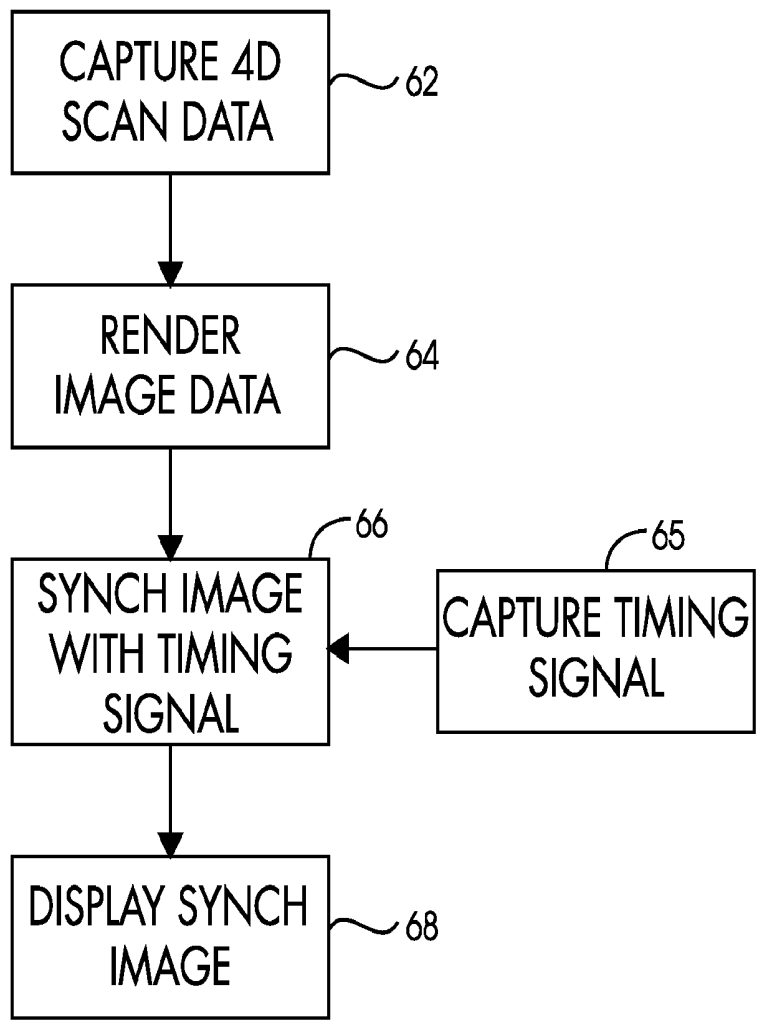

FIG 14

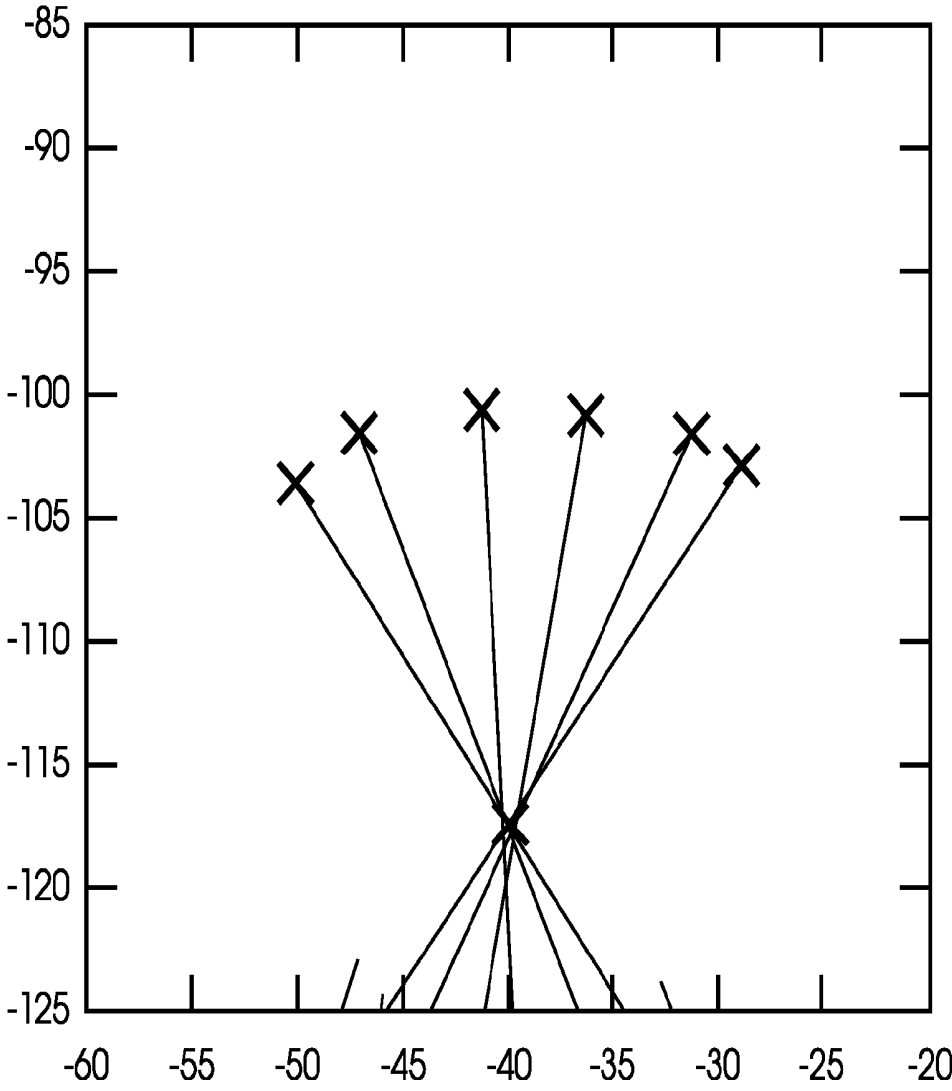

FIG 15

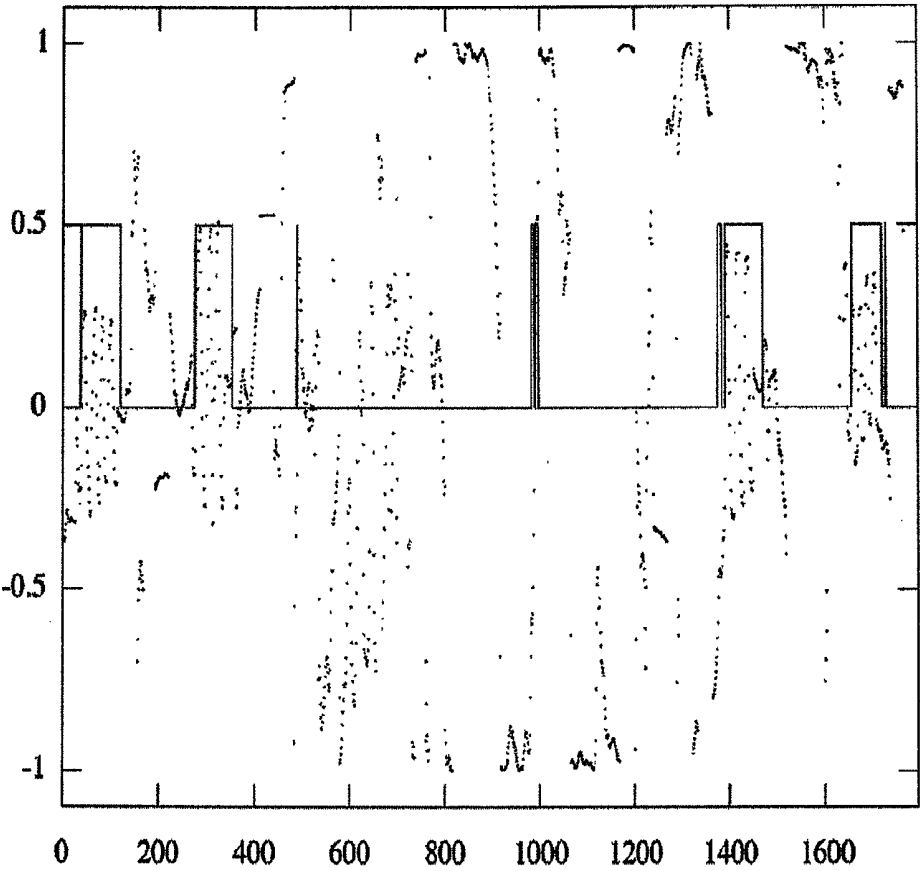

Figure 16

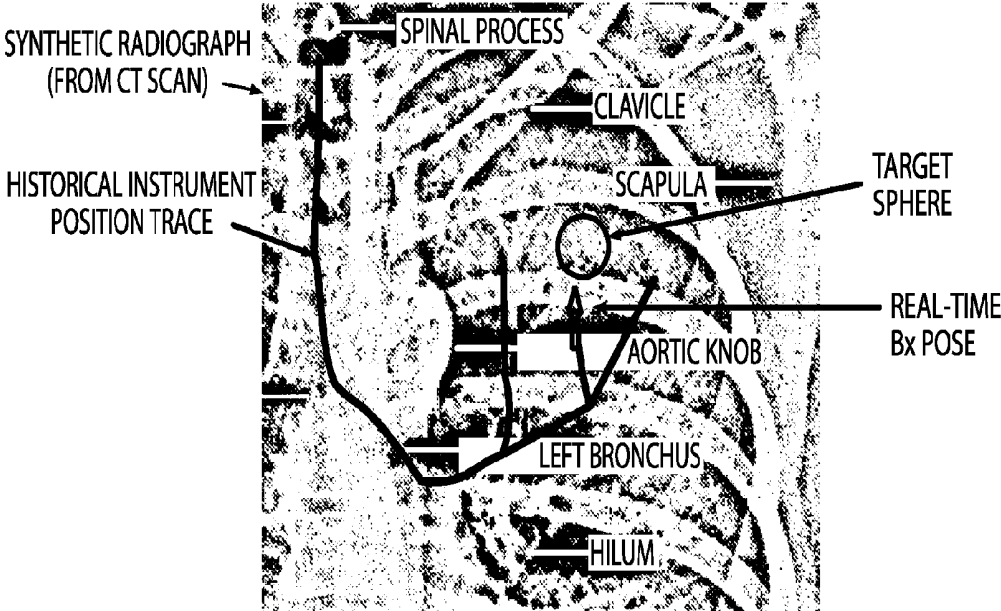

FIG 17

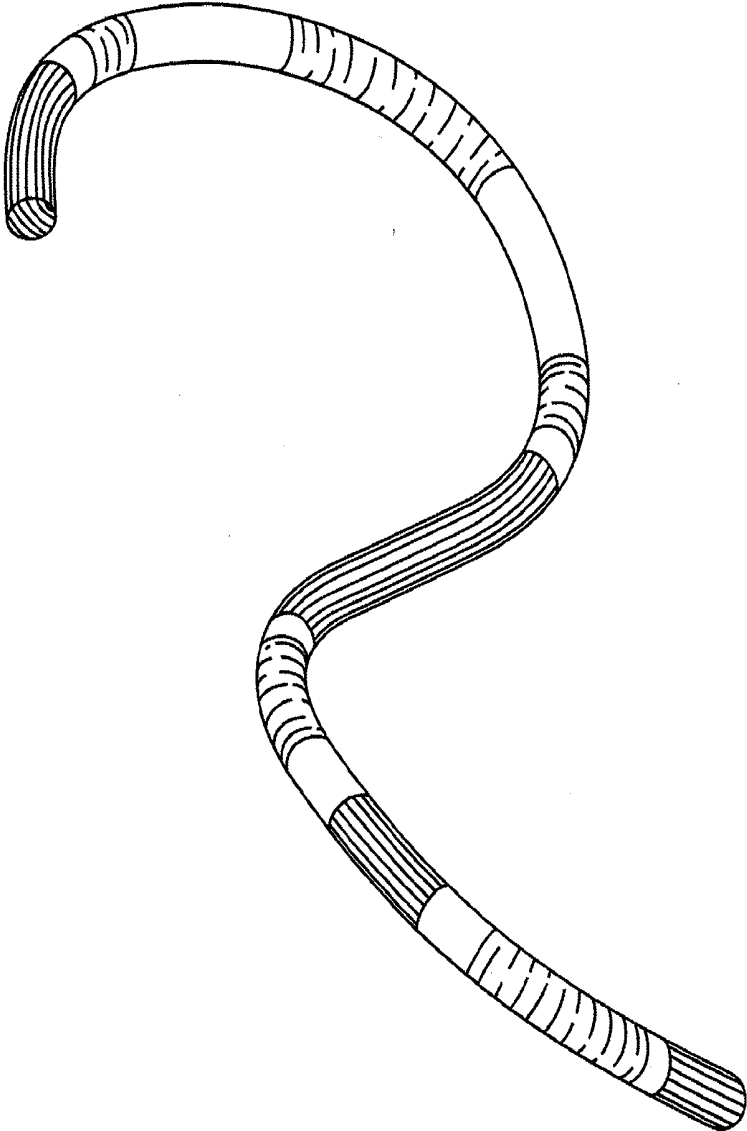
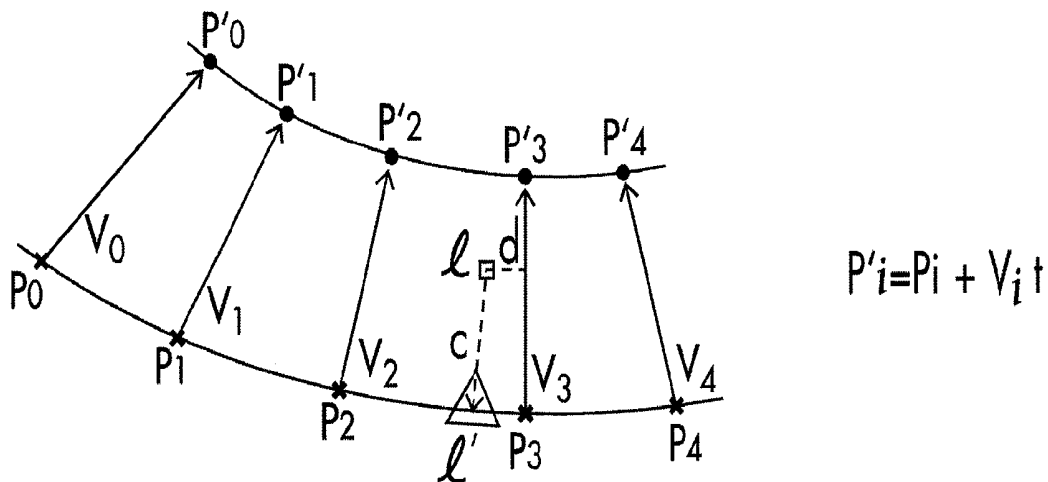

FIG 18



$P_i \equiv$ patient anatomy at expiration
 $P'_i \equiv$ patient anatomy at inspiration
 $V_i \equiv$ expiration to inspiration deformation vector
 $l \equiv$ 3D localized point
 $d \equiv$ distance to nearest V_i (point to line)
 $c \equiv$ real time respiration correction vector
 (variables and algorithm also applicable to heartbeat, vessel motion, etc.)

FIG 19

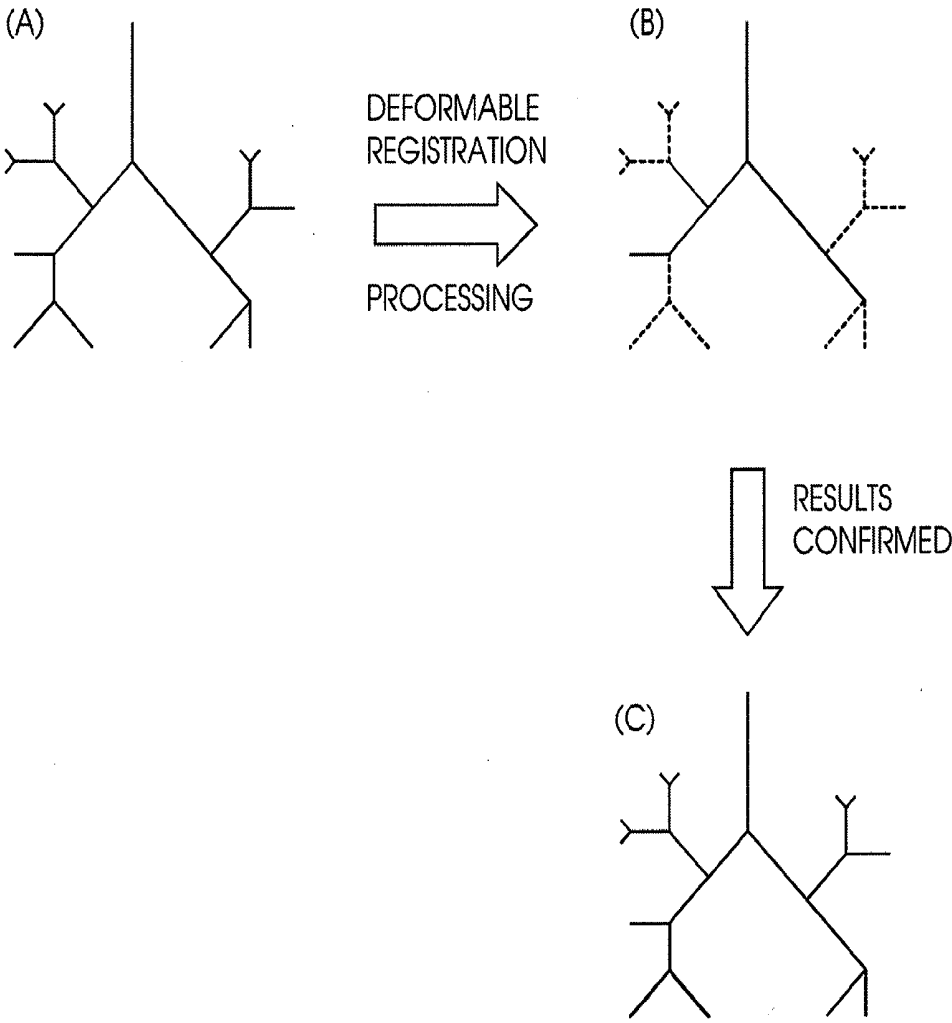

FIG 20

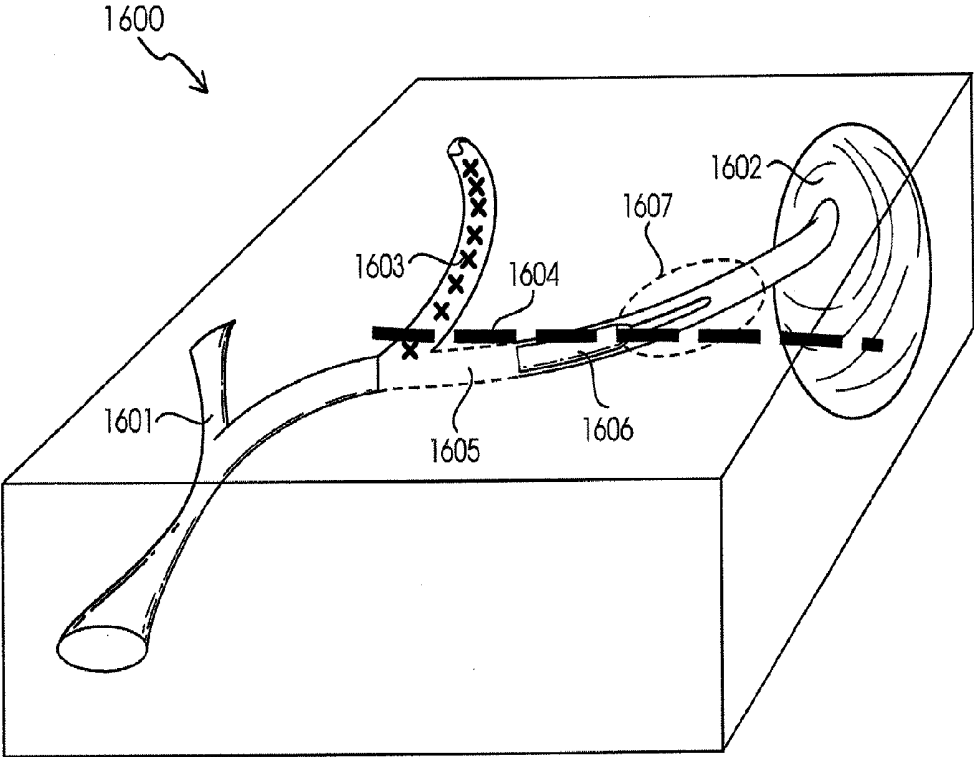

FIG 21

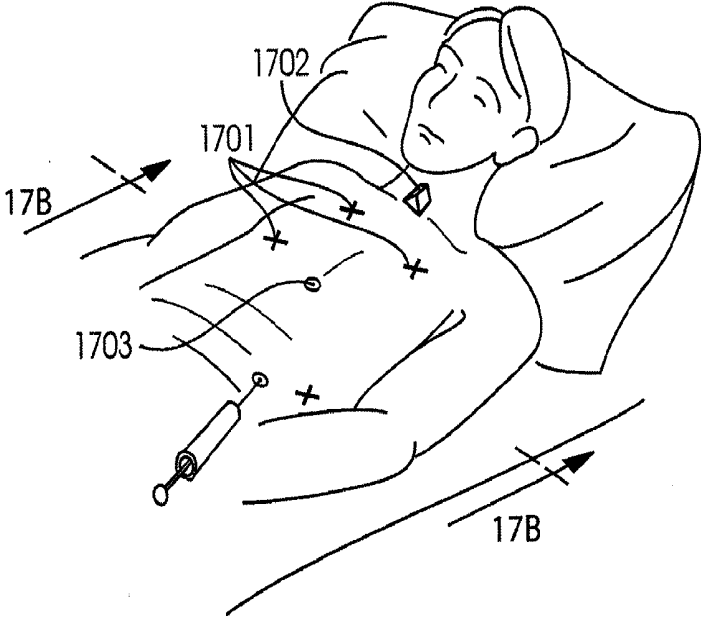

FIG 22A

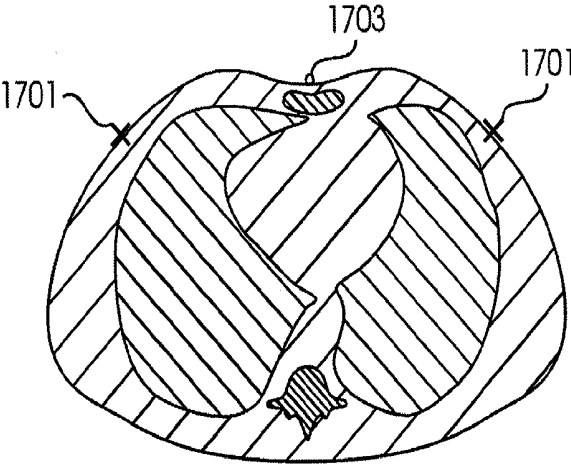

FIG 22B

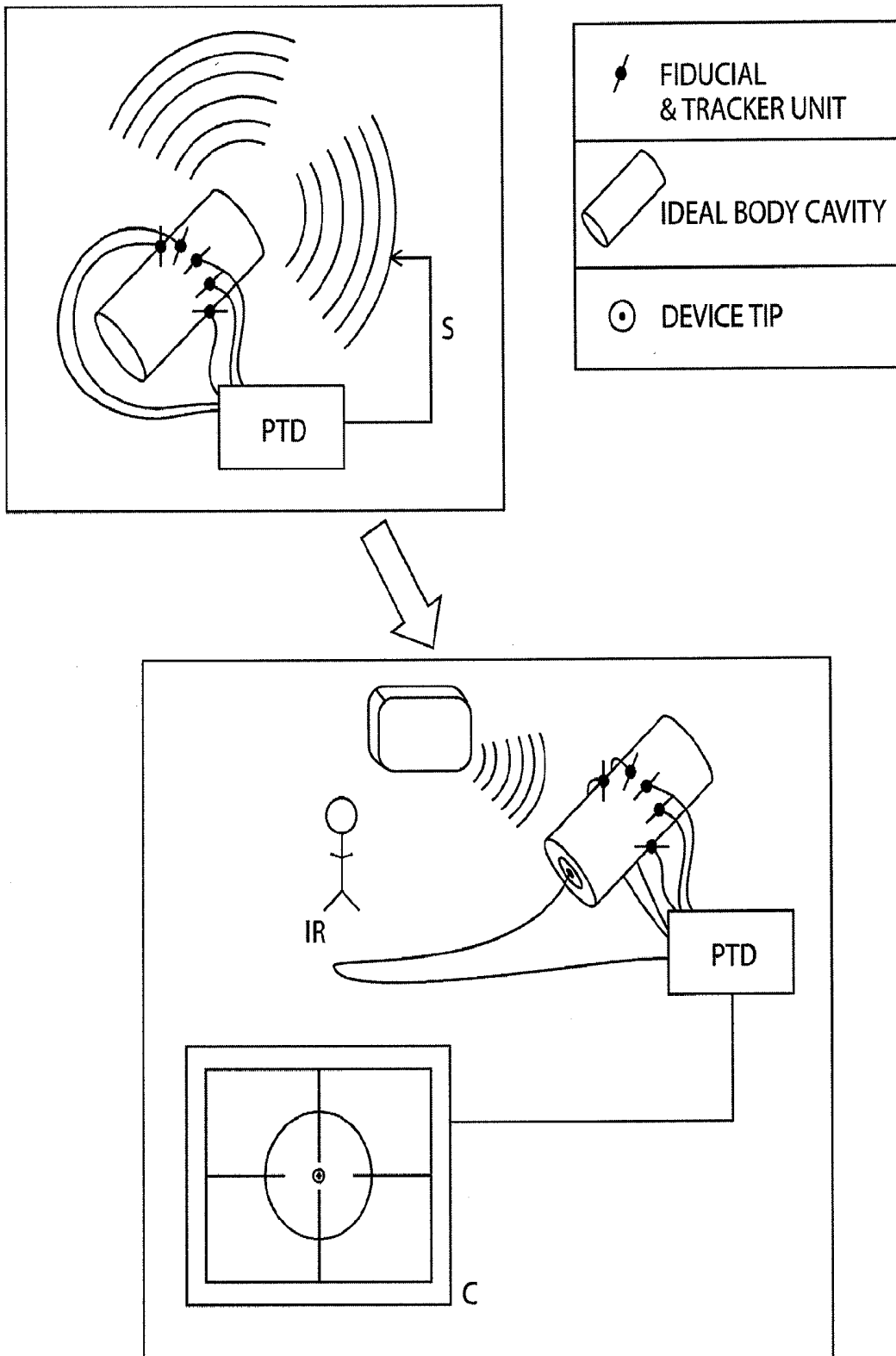

FIG 23

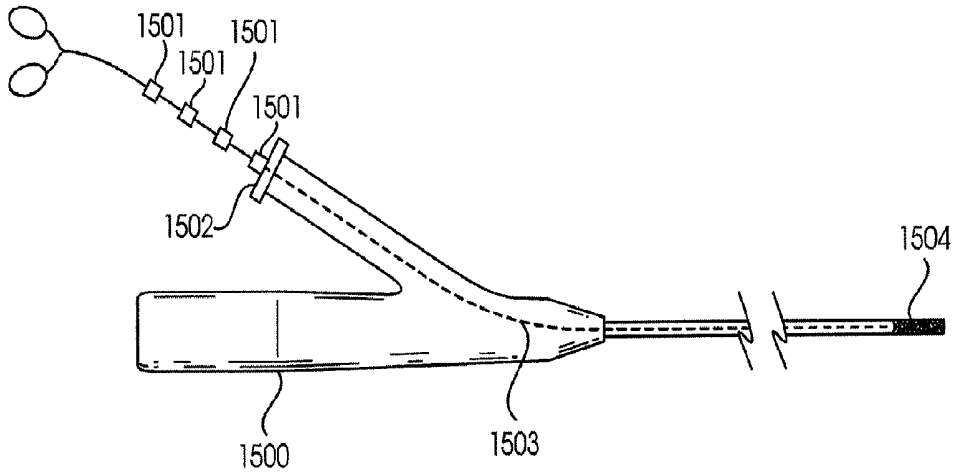

FIG 24A

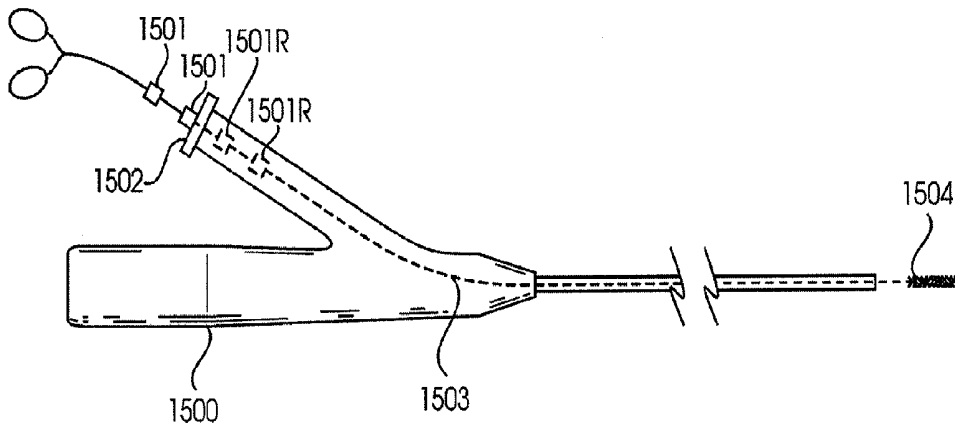

FIG 24B

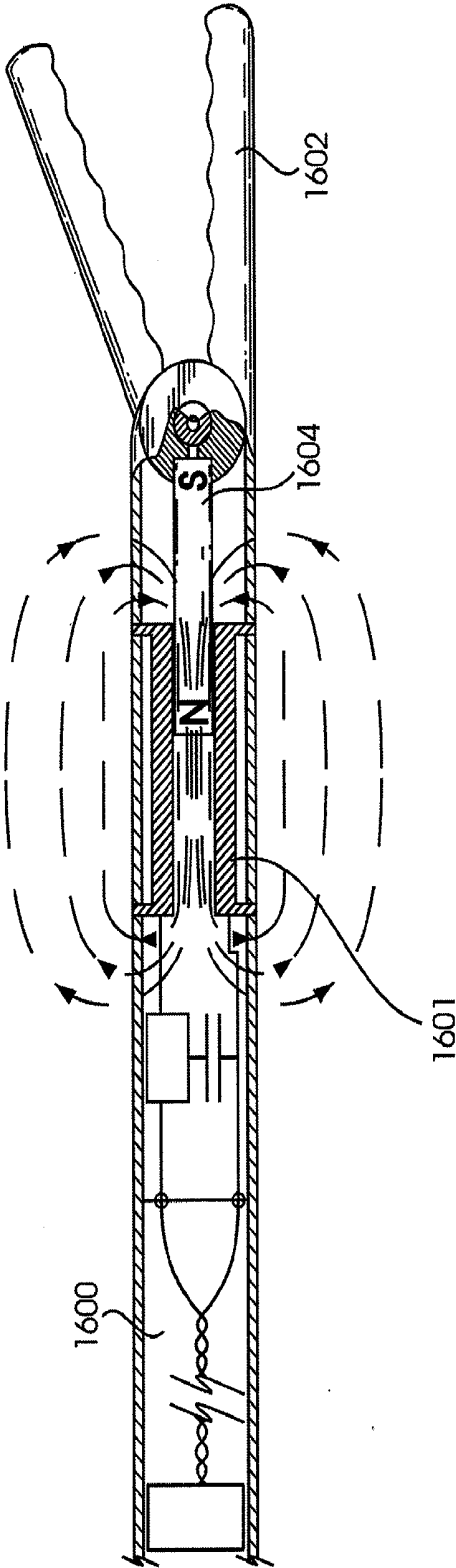

FIG 25

APPARATUS AND METHOD FOR FOUR DIMENSIONAL SOFT TISSUE NAVIGATION

CROSS-REFERENCE TO RELATED APPLICATIONS

[0001] This application claims the benefit of U.S. Provisional Application Ser. Nos. 61/375,439, filed Aug. 20, 2010, 61/375,484, filed Aug. 20, 2010, 61/375,523, filed Aug. 20, 2010, and 61/375,533, filed Aug. 20, 2010, each of which are hereby incorporated by reference in their entirety, including any figures, tables, and drawings.

BACKGROUND

[0002] The invention relates generally to a medical device and particularly to an apparatus and methods associated with a range of image guided medical procedures.

[0003] Image guided surgery (IGS), also known as image guided intervention (IGI), enhances a physician's ability to locate instruments within anatomy during a medical procedure. IGS can include 2-dimensional (2-D), 3-dimensional (3-D), and 4-dimensional (4-D) applications. The fourth dimension of IGS can include multiple parameters either individually or together such as time, motion, electrical signals, pressure, airflow, blood flow, respiration, heartbeat, and other patient measured parameters.

[0004] Existing imaging modalities can capture the movement of dynamic anatomy. Such modalities include electrocardiogram (ECG)-gated or respiratory-gated magnetic resonance imaging (MRI) devices, ECG-gated or respiratory-gated computer tomography (CT) devices, standard computed tomography (CT), 3D Fluoroscopic images (Angio-suites), and cinematography (CINE) fluoroscopy and ultrasound. Multiple image datasets can be acquired at different times, cycles of patient signals, or physical states of the patient. The dynamic imaging modalities can capture the movement of anatomy over a periodic cycle of that movement by sampling the anatomy at several instants during its characteristic movement and then creating a set of image frames or volumes.

[0005] A need exists for an apparatus that can be used with such imaging devices to capture pre-procedural or intra-procedural images of a targeted anatomical body and use those images intra-procedurally to help guide a physician to the correct location of the anatomical body during a medical procedure.

SUMMARY OF THE INVENTION

[0006] A method includes receiving during a first time interval image data associated with an image of a dynamic body. The image data includes an indication of a position of a first marker on a patient tracking device (PTD) coupled to the dynamic body and a position of a second marker on the PTD. Some registration methods such as 2D to 3D registration techniques allow for the image data containing the target or patient anatomy of interest to not contain the PTD. A registration step is performed to calculate the transformation from image space to patient space using an additional dataset to register (i.e., a 2D fluoroscopic set of images is used to register a 3D fluoroscopic dataset). This technique is not limited to fluoroscopic procedures as it can be implemented in any procedure acquiring 2D images such as ultrasound, OCT (optical coherence tomography), EBUS (endobronchial ultrasound), or IVUS (intravascular ultrasound). This technique uses the

markers that are within multiple 2D images to register the 3D volume that is reconstructed from these 2D images. The reconstructed 3D volume is smaller than the field of view of the 2D images, so this technique allows for the PTD markers to be visible in a subset of the 2D images, but not within the 3D volume. In certain embodiments, the first marker is coupled to the PTD at a first location and the second marker is coupled to the PTD at a second location. A distance between the position of the first marker and the position of the second marker is determined. During a second time interval after the first time interval, data associated with a position of a first localization element coupled to the PTD at the first location and data associated with a position of a second localization element coupled to the PTD at the second location are received. A distance between the first localization element and the second localization element based on the data associated with the position of the first localization element and the position of the second localization element is determined. A difference is calculated between the distance between the first marker and the second marker during the first time interval and the distance between the first localization element and the second localization element during the second time interval. In addition the PTD device can be tracked continuously during the procedure and a sequence of motion of the PTD device that represents the patient motion of an organ or the patient's respiratory cycle can be collected. The sequence of motion can then be analyzed to find unique similar points within the dataset and grouped.

[0007] Other objects and features will be in part apparent and in part pointed out hereinafter.

BRIEF DESCRIPTION OF THE DRAWINGS

[0008] The details of the present invention, both as to its construction and operation can best be understood with reference to the accompanying drawings, in which like numerals refer to like parts, and in which:

[0009] FIG. 1 is a schematic illustration of various devices used with a method according to an embodiment of the invention.

[0010] FIG. 2 is a schematic illustration of various devices used with a method according to an embodiment of the invention.

[0011] FIG. 3 is a schematic illustrating vector distances on an apparatus according to an embodiment of the invention.

[0012] FIG. 4A is a schematic illustrating vector distances from a localization device according to an embodiment of the invention.

[0013] FIG. 4B is a schematic illustrating vector distances from image data according to an embodiment of the invention.

[0014] FIG. 5 is a front perspective view of an apparatus according to an embodiment of the invention.

[0015] FIG. 6 is a graphical representation illustrating the function of an apparatus according to an embodiment of the invention.

[0016] FIG. 7 is a flowchart illustrating a method according to an embodiment of the invention.

[0017] FIG. 8 shows the layout of a system that may be used to carry out image guided interventions using certain of the present methods that involve gated datasets.

[0018] FIG. 9 illustrates one example of samples of a periodic human characteristic signal (specifically, an ECG waveform) associated, or gated, with images of dynamic anatomy.

[0019] FIG. 10 is a diagram of an exemplary surgical instrument navigation system in accordance with present invention;

[0020] FIG. 11 is a flowchart that depicts a technique for simulating a virtual volumetric scene of a body cavity from a point of view of a surgical instrument positioned within the patient in accordance with the present invention;

[0021] FIG. 12 is an exemplary display from the surgical instrument navigation system of the present invention;

[0022] FIG. 13 is a flowchart that depicts a technique for synchronizing the display of an indicia or graphical representation of the surgical instrument with cardiac or respiratory cycle of the patient in accordance with the present invention; and

[0023] FIG. 14 is a flowchart that depicts a technique for generating four-dimensional image data that is synchronized with the patient in accordance with the present invention.

[0024] FIG. 15 is a graph depicting an axis or point that the instrument (e.g., a bronchoscope) deflects in a single planar direction. The graph shows the instrument (e.g., a bronchoscope) being maneuvered in six different orientations in a 3D localizer volume, with all orientations converging about a common axis or point of deflection.

[0025] FIG. 16 is a graph depicting the eigenvalues (e_0, e_1, e_2) for a moving 3.0 sec PCA (principal component analysis) window over a data file including 1800 samples. The square wave represents an on/off “wobble detector” state based on the algorithm described herein, and this square wave demonstrates that the algorithm exhibits no false negatives for the validation test data and that the seven exemplary “wobble” periods are clearly matched to the “on” state of the wobble detector. The implementation of the algorithm uses low pass filtering and an appropriate comparator function to eliminate any false positive traces or spots (“blips”) indicated in FIG. 16.

[0026] FIG. 17 is an image of an exemplary synthetic radiograph in accordance with the present invention, depicting the historical instrument position trace.

[0027] FIG. 18 depicts an exemplary curvature warning system in accordance with the invention described herein.

[0028] FIG. 19 depicts an exemplary real-time respiration compensation algorithm.

[0029] FIG. 20 depicts additional and alternative exemplary embodiments of the invention described herein.

[0030] FIG. 21 depicts additional and alternative exemplary embodiments of the invention described herein.

[0031] FIGS. 22A and 22B depict additional and alternative exemplary embodiments of the invention described herein.

[0032] FIG. 23 depicts additional and alternative exemplary embodiments of the invention described herein.

[0033] FIGS. 24A and 24B depict exemplary embodiments of an port offset device in accordance with the invention described herein.

[0034] FIG. 25 depicts exemplary embodiments of a actuable sensor-equipped forceps device in accordance with the invention described herein.

DETAILED DESCRIPTION

[0035] The accompanying Figures and this description depict and describe embodiments of a navigation system (and related methods and devices) in accordance with the present invention, and features and components thereof. It should also be noted that any references herein to front and back, right and left, top and bottom and upper and lower are

intended for convenience of description, not to limit the present invention or its components to any one positional or spatial orientation.

[0036] It is noted that the terms “comprise” (and any form of comprise, such as “comprises” and “comprising”), “have” (and any form of have, such as “has” and “having”), “contain” (and any form of contain, such as “contains” and “containing”), and “include” (and any form of include, such as “includes” and “including”) are open-ended linking verbs. Thus, a method, an apparatus, or a system that “comprises,” “has,” “contains,” or “includes” one or more items possesses at least those one or more items, but is not limited to possessing only those one or more items. For example, a method that comprises receiving a position of an instrument reference marker coupled to an instrument; transforming the position into image space using a position of a non-tissue internal reference marker implanted in a patient; and superimposing a representation of the instrument on an image in which the non-tissue internal reference marker appears possesses at least the receiving, transforming, and superimposing steps, but is not limited to possessing only those steps. Accordingly, the method also covers instances where the transforming includes transforming the position into image space using a transformation that is based, in part, on the position of the non-tissue internal reference marker implanted in the patient, and calculating the transformation using image space coordinates of the internal reference marker in the image. The term “use” should be interpreted the same way. Thus, a calculation that uses certain items uses at least those items, but also covers the use of additional items.

[0037] Individual elements or steps of the present methods, apparatuses, and systems are to be treated in the same manner. Thus, a step that calls for creating a dataset that includes images, one of the images (a) depicting a non-tissue internal reference marker, (b) being linked to non-tissue internal reference marker positional information, and (c) being at least 2-dimensional covers the creation of at least such a dataset, but also covers the creation of a dataset that includes images, where each image (a) depicts the non-tissue internal reference marker, and (b) is linked to non-tissue internal reference marker positional information.

[0038] The terms “a” and “an” are defined as one or more than one. The term “another” is defined as at least a second or more. The term “coupled” encompasses both direct and indirect connections, and is not limited to mechanical connections.

[0039] Those of skill in the art will appreciate that in the detailed description below, certain well known components and assembly techniques have been omitted so that the present methods, apparatuses, and systems are not obscured in unnecessary detail.

[0040] An apparatus according to an embodiment of the invention includes a PTD and two or more markers coupled to the PTD. The apparatus can also include two or more localization elements coupled to the PTD proximate the markers. The apparatus is configured to be coupled to a dynamic body, such as selected dynamic anatomy of a patient. Dynamic anatomy can be, for example, any anatomy that moves during its normal function (e.g., the heart, lungs, kidneys, liver and blood vessels). A processor, such as a computer, is configured to receive image data associated with the dynamic body taken during a pre-surgical or pre-procedural first time interval. The image data can include an indication of a position of each of the markers for multiple instants in time during the first time

interval. The processor can also receive position data associated with the localization elements during a second time interval in which a surgical procedure or other medical procedure is being performed. The processor can use the position data received from the localization elements to determine a distance between the elements for a given instant in time during the second time interval. The processor can also use the image data to determine the distance between the markers for a given instant in time during the first time interval. The processor can then find a match between an image where the distance between the markers at a given instant in time during the first time interval is the same as the distance between the elements associated with those markers at a given instant in time during the medical procedure, or second time interval. Additionally, the processor can determine a sequence of motion of the markers and match this sequence of motion to the recorded motion of the markers over the complete procedure or significant period of time. Distance alone between the markers may not be sufficient to match the patient space to image space in many instances, it is important for the system to know the direction the markers are moving and the range and speed of this motion to find the appropriate sequence of motion for a complex signal or sequence of motion by the patient.

[0041] A physician or other healthcare professional can use the images selected by the processor during a medical procedure performed during the second time interval. For example, when a medical procedure is performed on a targeted anatomy of a patient, such as a heart or lung, the physician may not be able to utilize an imaging device during the medical procedure to guide him to the targeted area within the patient. A PTD according to an embodiment of the invention can be positioned or coupled to the patient proximate the targeted anatomy prior to the medical procedure, and pre-procedural images can be taken of the targeted area during a first time interval. Markers or fiducials coupled to the PTD can be viewed with the image data, which can include an indication of the position of the markers during a given path of motion of the targeted anatomy (e.g., the heart) during the first time interval. Such motion can be due, for example, to inspiration (i.e., inhaling) and expiration (i.e., exhaling) of the patient, or due to the heart beating. During a medical procedure, performed during a second time interval, such as a procedure on a heart or lung, the processor receives data from the localization elements associated with a position of the elements at a given instant in time during the medical procedure (or second time interval). The distance between selected pairs of markers can be determined from the image data and the distance, range, acceleration, and speed between corresponding selected pairs of localization elements can be determined based on the element data for given instants in time. From multiple image datasets the range and speed of the markers motion can be calculated.

[0042] Because the localization elements are coupled to the PTD proximate the location of the markers, the distance between a selected pair of elements can be used to determine an intra-procedural distance between the pair of corresponding markers to which the localization elements are coupled. An image from the pre-procedural image data taken during the first time interval can then be selected where the distance between the pair of selected markers in that image corresponds with or closely approximates the same distance determined using the localization elements at a given instant in time during the second time interval. This process can be done

continuously during the medical procedure, producing simulated real-time, intra-procedural images illustrating the orientation and shape of the targeted anatomy as a catheter, sheath, needle, forceps, guidewire, fiducial delivery devices, therapy device (ablation modeling, drug diffusion modeling, etc.), or similar structure(s) is/are navigated to the targeted anatomy. Thus, during the medical procedure, the physician can view selected image(s) of the targeted anatomy that correspond to and simulate real-time movement of the anatomy. In addition, during a medical procedure being performed during the second time interval, such as navigating a catheter or other instrument or component thereof to a targeted anatomy, the location(s) of a sensor (e.g., an electromagnetic coil sensor) coupled to the catheter during the second time interval can be superimposed on an image of a catheter. The superimposed image(s) of the catheter can then be superimposed on the selected image(s) from the first time interval, providing simulated real-time images of the catheter location relative to the targeted anatomy. This process and other related methods are described in pending U.S. patent application Ser. No. 10/273,598, entitled *Methods, Apparatuses, and Systems Useful in Conducting Image Guided Interventions*, filed Nov. 8, 2003, the entire disclosure of which is incorporated herein by reference.

[0043] In one embodiment, a real-time pathway registration is applied to a pre-acquired dataset that does not contain the PTD. It will be understood that the pre-acquired dataset can be at only one cycle of a patient's respiratory, heartbeat, or other path of motion. In order to optimize the registration of a pre-acquired dataset that does not contain the PTD, a PTD can be subsequently applied to the patient, and the PTD signal can be used to collect registration information throughout full range or path of motion but only that information that is captured at a similar PTD orientation, shape, or point along the PTD cycle of motion is used. This method enhances the registration accuracy by ensuring that the registration points being used to register are at the same point during the initial dataset acquisition. In preferred embodiments, the method uses multiple subsets of the acquired registration data that are collected based on the PTD signal. These multiple subsets are then applied against the pre-acquired dataset to find the optimal registration fit.

[0044] In another embodiment, the device can be integrated with one or more fiber optic localization (FDL) devices and/or techniques. In this way, the sensor (such as an EM sensor) provides the 3D spatial orientation of the device, while the FDL provides shape sensing of the airway, vessel, pathway, organ, environment and surroundings. Conventional FDL techniques can be employed. In various embodiments, for example, the FDL device can be used to create localization information for the complete pathway or to refine the localization accuracy in a particular segment of the pathway. By either using 3D localization information, shape, or both detected by the FDL device, the system can use a weighted algorithm between multiple localization devices to determine the location and orientation of the instrument in the patient. The FDL device can also be used as or in conjunction with the PTD to track the patient's motion such as respiration or heartbeat.

[0045] Other aspects involve using a guidewire or other navigated instrument with one to one rotation to continuously align a virtual display view to be consistent with the actual bronchoscopic video view. A similar technique can be used

with OCT, IVUS, or EBUS devices to orient the virtual view to the image captured by the OCT, IVUS, or EBUS devices.

[0046] Other aspects involve using video input of the bronchoscope to adjust the virtual “fly-through” view to be consistent with the user’s normal perspective. For example, conventional video processing and matching techniques can be used to align the real-time video and the virtual image.

[0047] Other aspects involve using bronchoscopic video to provide angular information at a current location to provide targeting or directional cues to the user. Angular information can be derived from the location of patient anatomy in the image and the relative size of each within the image. Using information extracted from the video captured by the bronchoscope, the system can determine which the direction of the display. This can be done using, for example, translation, rotation, or a combination of both. Comparing the real-time image captured to the virtual image constructed from the 3D dataset (i.e., CT) the system can use this information to align the virtual image and/or enhance the system accuracy.

[0048] In another aspect, a high-speed three-dimensional imaging device, such as an optical coherence tomography (OCT) device, can be tracked. In accordance with conventional methods, such a device can only view 1-2 mm below the surface. With an EM sensor attached in accordance with the systems and methods described herein, multiple 3D volumes of data can be collected and a larger 3D volume of collected data can be constructed. Knowing the 3D location and orientation of the multiple 3D volumes will allow the user to view a more robust image of, for example, pre-cancerous changes in the esophagus or colon. This data can also be correlated to pre-acquired or intra-procedurally acquired CT, fluoroscopic, ultrasound, or 3D fluoroscopic images to provide additional information.

[0049] Among several potential enhancements that could be provided by an endoluminal system as described herein is that a user could overlay the planned pathway information on to the actual/real-time video image of the scope or imaging device (such as ultrasound based device). Additionally, the system and apparatus could provide a visual cue on the real-time video image showing the correct direction or pathway to take.

[0050] Additionally, or alternatively, one could use a 5DOF sensor and a limited or known range of motion of a localization device to determine its orientation in the field. This is particularly relevant, for example, in determining which way is up or down or the overall rotation of an image in 3D space. In bronchoscopy, for instance, this can be used to orient the bronchoscopic view to the user’s normal expected visual orientation. Because a bronchoscope is typically only able to move in one plane up and down, the system can use the 3D location of a tip sensor moving up and down to determine the sixth degree of freedom. In this implementation, a user could steer the bronchoscope to a bifurcation or close to a bifurcation and then perform a motion with the scope (e.g., up and down) using the thumb control to wiggle or flutter the tip and sensor. With this motion (i.e., described herein generally as the “wiggle maneuver”), the system can determine the orientation and display the correct image. Typically, 5DOF sensing of instrument tip POSE (position and orientation) determines 5 of the 6 POSE parameters (x, y, z, pitch, and yaw). Such sensing may be unable in certain applications, however, to determine the instantaneous roll of the device. This roll determination can be critical in matching the video coming from the device to the images. The techniques described herein

advantageously allow for users to relate orientation of a virtual endoscopic “fly-thru” display to actual video orientation presented by the endoscopic instrument.

[0051] In general, the methods described herein provides for the user to select a location, most typically at a branching point in the bronchial tree, and perform a “wiggle” maneuver with the tip of the device. In preferred embodiments, the wiggle maneuver generally consists of three steps:

[0052] (i). At desired branch or other point, the physical or translational location of device is substantially secured or held in place. For example, with a bronchoscope, the user should ensure that the scope is held securely so it cannot translate relative to the airway.

[0053] (ii). Perform a tip wiggle in plane by a rhythmic actuation of the scope steering mechanism. The magnitude of the actuation should be sufficient in force for the tip to cover an approximate 1 cm-2 cm range of motion, but less motion may be sufficient in some applications or embodiments.

[0054] (iii). Continue the wiggle maneuver, keeping the scope itself substantially stationary until the systems described herein and related software defines the sixth degree of freedom, and the orientation of the video display of scope matches the virtual “fly-thru”.

[0055] Algorithmically, a manifestation of an algorithm to detect this operation consists of recognizing a unique signature of motion over time. One such technique, for example, consists of two parts:

[0056] (a) performance of a continuous PCA analysis of a specified time window of 5DOF sensor locations. A repeated motion in a plane by the instrument tip will produce a covariance matrix such that the foremost eigenvalue (e_0) will reflect the variance of a 1 cm-2 cm motion over a given time window. In addition, the secondary and tertiary eigenvalues (e_1 and e_2) will reflect a very small variance, as the tip should preferably be moving in an arc constrained to the plane defined by the spline mechanism of the scope.

[0057] (b) once an appropriate PCA signature is detected, orientation of the tip to the eigenvector E_0 , which represents the historical vector of motion for the instrument tip, is compared. An exemplary way to do this is the dot product of the measured tip vector and E_0 , which represents the acute angle.

$$r = V \cdot E_0$$

[0058] By way of example and not by way of limitation, in an ideal wiggle maneuver, the orientation of the tip should show a rhythmic oscillation of about 90° (approximate range could be for instance $\pm 45^\circ$). This comparison of tip orientation to E_0 provides the basis for a determination of the wiggle plane normal using, for example, a cross-product or gram-schmidt orthogonalization. The physical wiggle plane normal is in a constant relationship to the coordinate space of the video signal, and thus can be related (calibrated) thereto.

[0059] Interestingly, this algorithm can be used in a variety of different modes to detect certain forms of scope motion:

[0060] stationary scope (wherein the e_0 , e_1 , and e_2 values will be very small and roughly equal, representing the small magnitude, unbiased Gaussian noise of the direct localization measurement);

[0061] scope in motion along a straight line in space, such as when traversing individual segments (wherein the e_0 will be very large, with very small e_1 and e_2 values, representing a large co-linear translation in space). In addition, the absolute value of r will be close

to 1, indicating that the orientation of the tip is nearly collinear with the translation of the tip over time.

[0062] In general, the wiggle techniques described herein for determining direction and orientation, including “up” and “down” orientation relative to (or independent of) the instrument steering mechanism, may be used in a range of different endoscopic applications. Although the above examples and embodiments generally refer to the use of the wiggle maneuver in connection with bronchoscopic applications, it will be understood that the techniques described herein may also be used in other applications including, but not limited to, enteroscopy, colonoscopy, sigmoidoscopy, rhinoscopy, proctoscopy, otoscopy, cystoscopy, gynecoscopy, colposcopy, hysteroscopy, fallopscopy, laparoscopy, arthroscopy, thoracoscopy, amnioscopy, fetoscopy, panendoscopy, epiduroscopy, and the like. The wiggle techniques described herein may also be applicable in non-medical endoscopic uses, such as the internal inspection of complex technical systems, surveillance, and the like.

[0063] In general, the methods described herein employ successive approximation techniques of pathway planning, and enhanced localization accuracy to use traveled pathway information to continuously, substantially continuously, or serially update pathway planning and localization accuracy. The limits of automatic pathway or vessel segments are generally defined, for example, by the quality of the image data provided or the state the patient may be in when the image data is acquired. Therefore, in some cases the pathway segmentation may not extend completely to the target (that is, the pathway segmentation stops short of the target). One method to enhance the segmentation involves using the traveled path of a tracked instrument to add branches and segment(s) to the pathway. Methods may include multiple approaches described herein such as recording traveled paths or using the additional path traveled information to iteratively segment vessels or airways from the image dataset. Having the additional knowledge that an instrument actually traveled the path can enable an automatic segmentation algorithm to extend the vessels and airways that it can calculate and find. This can be particularly valuable in situations where airways or vessels may be obstructed or pinched off. This technique can also be a valuable tool in recording the paths traveled by the instrument to give an indication to the user of “good” and “bad” (i.e., correct or incorrect, direct or indirect, etc.) directions based, for instance, on trial and error.

[0064] According to the various methods and systems described herein, therefore, in some embodiments real-time pathway registration uses full 5D and/or 6D information and/or details of instrument location to enhance registration. These and other methods can employ distance, proximity, and/or angle information, for example, to determine the pathway being traversed in order to optimize localization accuracy. This can be particularly beneficial at the bifurcation(s) of vessels and airways, where an initial (or subsequent) selection of the correct direction is important to accurately navigate the desired pathway. Using both 3D localization and the orientational and/or directional angle of the device can, in various embodiments, be helpful in maximizing accuracy in applications such as an endoluminal navigation system. Advance knowledge of the various segmented vessels and/or airways in a procedural or pre-procedural setting, and the orientation and/or direction of the navigated instrument, can further enhance accuracy. In certain embodiments, the various parameters (e.g., distance, angle, etc.) can be weighted in

real-time (or near-real-time) for improved application or use of the relevant information. For example, distance information can be used in the relevant algorithms without taking angle information into account, or vice versa. Or, for example, the various parameters can be equally applied (e.g., 50% angle, 50% proximity). Additionally or alternatively, different percentages can be applied to emphasize or weigh one parameter over another (e.g., 15% angle, 85% proximity; 20% angle, 80% proximity; 25% angle, 75% proximity; 30% angle, 70% proximity; 35% angle, 65% proximity; 40% angle, 60% proximity; or 45% angle, 65% proximity; or, alternatively, 15% proximity, 85% angle; 20% proximity, 80% angle; 25% proximity, 75% angle; 30% proximity, 70% angle; 35% proximity, 65% angle; 40% proximity, 60% angle; 45% proximity, 65% angle). In operation, it may be preferable to more heavily weigh angle information when the instrument arrives at a branch (e.g., an arterial branch) in order to facilitate or improve directional decision-making in real-time; weighting the parameters in this manner, therefore, can further improve accuracy.

[0065] According to one embodiment, the real-time pathway registration uses path traveled of the instrument location to enhance registration. Using path traveled to exclude other potential navigational solutions enhances navigational accuracy. Many times in patient anatomy vessel or airway branches may twist around and come close to one another, but it is obvious from earlier location(s) recorded along the path traveled that only one branch can be the correct navigated location.

[0066] According to one particular embodiment, the respiratory signal derived from the PTD is used to gate the localization information of the instrument in the airway. This can assist in determining multiple airway models, for example, by performing a best fit of the real-time patient airway model to the CT data to derive the optimal registration and gated period in the patient’s respiratory cycle. Additionally or alternatively, the respiratory signal can be derived from devices other than the PTD, such a device that records the resistance between two locations on the patient. For example, this method is similar to a variable potentiometer in that the resistance of the patient changes between two fixed points as the patient inhales and exhales. Thus, the resistance can be measured to create a respiratory signal.

[0067] According to another particular embodiment, 3D location information is used to extend the segmented airway model. The 3D airway can be extended as the instrument is passed along the airway by using this location information as an additional parameter to segment the airway from the CT data. Using an iterative segmentation process, for instance, the 3D location information of the instrument can be used to provide seed points, manual extension, or an additional variable of likelihood of a segmented vessel or airway existing in the 3D image volume. These added airways can be displayed in a different format or color (for example) to indicate to the user that they are extending the segmented airway using instrument location information.

[0068] In general, the embodiments described herein have applicability in “Inspiration to Expiration”-type CT scan fusion. According to various methods, the user navigates on the expiration CT scan for optimal accuracy, while using the inspiration scan to obtain maximum airway segmentation. In one embodiment, for example, a user could complete planning and pathway segmentation on an inspiration scan of the patient. Preferably, a deformation or vector field is created

between at least two datasets. The deformation or vector field may then be applied to the segmented vessels and/or airways and the user's planned path and target. In these and other embodiments, the deformation or vector field can also be applied to multiple datasets or in a progressive way to create a moving underlying dataset that matches the patient's respiratory or cardiac motion.

[0069] By way of example, "Inspiration to Expiration" CT fusion using the lung lobe centroid and vector change to modify an airway model may also be applicable. In accordance with various embodiments, this technique may be used to translate and scale each airway based on the lung lobe change between scans. The lung is constructed of multiple lobes and these lobes are commonly analyzed for volume, shape, and translation change. Each lobe changes in a very different way during the patient's breathing cycle. Using this information to scale and translate the airways that are located in each lobe, it is possible to adapt for airway movement. This scaled airway model can then be linked to the 4D tracking of the patient as described herein.

[0070] In one preferred embodiment, for example, a cine loop of ultrasound data is collected in conjunction with the patient's respiratory cycle information. This can serve to limit registration point selection, in order to be consistent with the patient's respiratory cycle that a 3D dataset such as CT, MR, or PET has acquired. This technique advantageously maximizes registration accuracy, a major flaw in conventional systems in the prior art.

[0071] In various aspects, the systems and methods described herein involve modifying inspiration CT scans to the expiration cycle for navigation. It is well understood that the patient's airways are contained within multiple lobes of the lung. It is also understood that airways significantly change between inspiration and expiration. In order to have the most accurate map for navigation it would be beneficial to include the detail of the inspiration scan, coupled with the ability to navigate it accurately during expiration, which is the most repeatable point in a patient's breath cycle. In preferred embodiments, this modification can be carried out in accordance with the following steps:

[0072] 1) Scan patient at both inspiration and expiration;

[0073] 2) Segment the airways in both the inspiration and expiration;

[0074] 3) Segment the lung lobes in both the inspiration and expiration (as the lung lobes are identifiable in both the inspiration and expiration scans with a high degree of accuracy);

[0075] 4) Determine a volume difference for each lung lobe between inspiration and expiration, use this change to shrink the airway size from the inspiration to the expiration cycle. Preferably, this is done for each individual lobe, as the percentage change will typically be different for each lobe.

[0076] 5) Determine the centroid for each lung lobe and the vector change in motion from the main carina in both scans. This vector can then be used to shift the airways that are associated with each lung lobe. A centroid for the airway can be calculated based on the segmented branches. For each airway branch in the segmentation, it includes a tag that associates it with the respective lung lobe. The central airway including the main carina and initial airway branches for each lobe that is linked according to the expiration scan location of these points. Next, a plane can be defined using the main carina and initial airway branch exits to determine the vector change for each lobe.

[0077] Among the lobes to modify, for example:

[0078] left inferior lobe—the bottom lobe of the lung on the left side of the body.

[0079] left superior lobe—the top lobe of the lung on the left side of the body.

[0080] right inferior lobe—the bottom lobe of the lung on the right side of the body.

[0081] right middle lobe—the middle lobe of the lung on the right side of the body.

[0082] right superior lobe—the top lobe of the lung on the right side of the body.

[0083] Exemplary calculations are as follows:

$$\text{Inspiration Airway} - \text{Left Inferior Lobe (LIL)} \times 70\% \\ (\text{reduction in volume Inspiration to Expiration} \\ \text{calculated}) = \text{ExAirwayLIL}$$

[0084] Determine Expiration Central Airway points (Main Carina and Initial Airway branches) based upon segmentation

[0085] Shift ExAirwayLIL by vector distance (3 cm, 45 degrees up and back from main carina) that LIL centroid moved from inspiration to expiration

[0086] Preferably, this process is repeated for each lobe. In preferred embodiments, the completion of 5 lobes will result in a Navigation Airway Map for the patient.

[0087] In various embodiments, the target location for the patient can be selected in the expiration scan and applied to the Navigation Airway Map. Alternatively, it may be selected in the Inspiration scan and adjusted based on the same or similar criteria as the inspiration airways. In either case, it can be adjusted individually or linked to the airway via a 3D network and moved in the same transformation.

[0088] One aspect of the present invention is directed to an endoscopic port offset device. The device includes, for example, a snap-on or otherwise affixable feature (that is, offsets) to the endoscopic (e.g., bronchoscopic) port that is capable of holding a navigated guidewire or instrument in a known or preset (i.e., predetermined) location to maintain device location and free the physician/user's hand. In one embodiment, for example, the device includes one or more offset portions that can be adjusted by combining and/or removing multiple offset segments. In another embodiment, for example, the device includes one or more offset portions that can be adjusted by the removal of one or more removable offset segments separated by perforations (i.e., in a disposable fashion). In yet another embodiment, the device includes an offset that is capable of adjustment using a screw mechanism (i.e., the length of the offset can be adjusted by screwing the offset in and out). In various embodiments, each offset can be represented on the navigation screen showing offset distance from the tip of the endoscope or working channel sheath. The endoscope or attachment thereof, in various embodiments, may include one or more offsets, two or more offsets, three or more offsets, four or more offsets, or five or more offsets. In other embodiments, more than five offsets may be included, e.g., 6-12 offsets, 6-18 offsets, 6-24 offsets, or more).

[0089] Another aspect of the invention is a closed loop system that allows the navigation system to steer the working channel using shape memory alloy/metal type materials. An instrument would have tracking sensors located at the tip for directional guidance as described herein that drive the micro-actuators along the shaft to turn corners. Using feedback from multiple sensors along the shaft it is also possible to determine the maximum points of friction and adjust the shape of the device to allow for easier insertion. One simple metric that

can be used, for example, is the difference in the shape or bend of the device to the segmented pathway of the vessel or airway, described in further detail below.

[0090] Other embodiments include, for example, detachable sensors to a fiducial structure (e.g., a reduced cost patient pad).

[0091] In accordance with other embodiments, for example, a sensor as described herein (e.g., an electromagnetic (EM) sensor) is affixed (preferably permanently affixed, but may also be removable) to a device or instrument so that both the device or instrument (or component thereof) and the sensor move together, such that they can be imaged and viewed. In one embodiment, for example, the device is an aspiration needle and the needle tip and the sensor move together. In another embodiment, for example, the device is a brush, forceps, or forceps tissue capture mechanism and these components and the sensor move together. In these and other embodiments, the device may additionally include an actuating handle (e.g., finger holds) that is coupled with the sensor, thus allowing movement tracking. These various embodiments advantageously allow the device (and components thereof) to be tracked using the sensor, improving overall accuracy and reliability.

[0092] In one particular embodiment, a sensor (e.g., an EM sensor) is positioned at or near the tip of a steerable catheter which further includes a side exiting working channel for forceps, aspiration needle, a brush, combinations thereof, and the like. Using the sensor (which in preferred embodiments is a 6DOF sensor as described herein), the user can have the direction of the side exiting working channel defined on the navigation screen. That is, the image plane that is generated is one at a side exiting working channel or port, as opposed to a point or position distal to the device. This will advantageously allow easier targeting of lesions that may not be directly in the airway, but rather partially or even completely outside of the airway. In accordance with an exemplary method of using the device, the catheter is steered slightly past the target to align the side exiting port/working channel; the sampling component (e.g., forceps, needle, brush) is then extended out the catheter. The directional aspect of the instrument can be viewed on the navigation screen and a simulated device can be shown to demonstrate to the user the tissue that will be sampled. These applications may be particularly useful in the sampling of lymph nodes that are outside the patient airways. In some embodiments, for example, the device may be capable of creating an endobronchial ultrasound (EBUS)-like view. For example, an image plane oriented with the working channel plane can be created and the instrument can be shown sampling the target on this plane. In various alternative embodiments, the image(s) may be oriented in a plane or orthogonally.

[0093] Other embodiments include, for example, using EM sensor as LC or energy transmission device. This stored energy could be used to actuate a sampling device such as forceps or power a diagnostic sensor.

[0094] Other embodiments include, for example, using an elastic tube length of scope or steerable catheter to add a sensor (e.g., an EM sensor) to a device. This may take the form of a flexible sheath or tube the length of a bronchoscope or steerable catheter that can be added to existing conventional instrumentation. In this way, the conventional device does not have to be modified. For instance, a very thin wall device can be slid over the length of the scope or catheter and it can be made navigational.

[0095] In accordance with another general aspect, the PTD comprises a pad that can be placed on the patient and left for a few hours or a few days. For example, such a device could be placed on a patient prior to a 3D image acquisition such as CT or MR. The device would contain EM (or other) sensors and an EM/LC tank circuit that would allow it be charged up or turned on once localization was ready to commence. The device could be wireless and transmit induced voltage levels back to the system to navigate in a 3D coordinate space as described herein.

[0096] In various embodiments, the device could either have a separate fiducial structure in a known orientation to the EM sensors, have the configuration learned by the system, or have EM sensors that act as fiducials in the 3D image scan.

[0097] As discussed herein, auto registration of a device is conducted, at least initially, by finding the PTD. In general, the PTD needs to be within the 3D volume, but for some devices the 3D volume may be too small to include both the PTD and the target. To overcome this, a 2D/3D algorithm can be employed in accordance with various embodiments, whereby multiple 2D images of a patient are acquired for a 3D volume reconstruction. The complete PTD (which may include one, two or multiple (e.g., at least 3) sensors or fiducials) does not need to be seen in each image; e.g., some images may only show one sensor or a part thereof, but the entire collection of 2D images can be compiled and used to find the whole or entire PTD relative to the target. For example, 180 2D images (or more or less depending on patient/device position, etc.) can be used to construct a complete 3D volume (where only a fraction (e.g., 10-30) of the 2D images include all or a portion of the PTD). This facilitates easier device placement and allows the user to focus on the target, as the PTD and target do not necessarily need to be in the same initial 3D volume.

[0098] One aspect is directed to recording 3D location and bronchoscopic video to construct a 3D model of the patient's airway. This 3D video can be recorded over multiple sessions (e.g., weeks between recording) and color, size, and shape analysis/change can be determined and/or compared for diagnostic purposes. Not only can airway lumen size and/or shape be compared, but a deformation or vector field can also be compared for the multiple sessions. This can be particularly valuable in determining overall lung function change as well as local changes to muscle and tissue elasticity.

[0099] Another similar aspect is directed to recording 3D location and EBUS video or images to construct a 3D model of the patient's airway or a lesion. Typically, the EBUS image is very small and 2D. Thus, recording multiple planes of EBUS can be used to create a 3D image of the lesion, lymph node, or blood vessels. Providing correlated CT information to the EBUS image can be valuable in determining the location of structures in the patient.

[0100] Yet another similar aspect is directed to recording 3D location and IVUS video or images to construct a 3D model of the patient's blood vessels or plaques. Like EBUS, the IVUS image is typically very small and 2D. Recording multiple planes of IVUS can be used to create a 3D image of the blood vessels and malformations. Providing correlated CT information to the IVUS image can be valuable in determining the location of structures in the patient. In accordance with this and other aspects, OCT may additionally or alternatively be employed.

[0101] In general, the methods described herein involve increasing registration accuracy for Ultrasound (US) to CT or

any other 3D image dataset such as MR, CT-PET, and 3D Ultrasound. Using 4D tracking of the patient respiratory signal and collecting a cine loop of ultrasound images, one can maximize the US to CT fusion accuracy by limiting the point or plane selection for registration to the correct respiratory cycle that matches the 3D dataset. The process involves the use of a patient tracker on the patient and a tracker on the US transducer; using a localizer (such as an EM localization system) to record a cine loop of US images and match the images in the cine loop to the respiratory signal.

[0102] Collecting a cine loop of US data for registration is valuable in that the user does not necessarily have to select a moving point while the patient is breathing. The user can simply scroll through the cine loop and, with an indicator of the point in the respiratory cycle, select the points that are best used for registration from a static image.

[0103] The user then selects, for example, at least 3 points in the US & CT datasets, or a plane and at least one point to register the US space to the 3D CT dataset space. Preferably, the points and plane are selected at the same respiratory point as the 3D CT dataset. Normally, for example, the 3D CT dataset would be acquired at exhalation. Therefore, the user preferably selects registration points at exhalation or significant errors can be incorporated into the US to CT registration. If a user was to select a plane that was at a different point in the respiratory cycle, for instance, there would be significant translation error in the registration. There would likely also be significant rotational error in the registration if the points were acquired at different points in the respiratory cycle.

[0104] The methods and systems described herein can be expanded to use other patient sensing information such as cardiac information (heartbeat) as a single source 4D signal or multiple sensed signal approach in that respiration and cardiac data could be used together. This is particularly relevant in connection with locations close to the heart or within the heart.

[0105] Preferably, the user selects points that are sufficiently far apart for the best accuracy. This can be done, for example, by requiring the user to record a cine loop of data that extends over the whole patient organ. Preferably, the user is not allowed to pick multiple points in the same image.

[0106] Another technique for maximizing registration accuracy is a centroid finding algorithm that can be used for refining point locations in a local area. Often, a user will want to select a vessel bifurcation. The vessel bifurcation will be seen as a bright white location on the CT and US images. An algorithm can be used to help the user select the optimal center location for these locations. Once a user selects a point on the image, the local algorithm can be employed to find similar white voxels that are connected and, for that shape in the 3D space, refine the point to the centroid or any other optimal point (such as, for example, the most anterior or most posterior point).

[0107] In general, the systems and methods described herein can be implemented regardless of the number of sensors that are used. In some embodiments, serial orientation or positioning of multiple sensors allows the determination of one or more parameters such as shape, position, orientation, and mechanical status of a complete or partial section of guidewire or other device or instrument. For example, the placement of multiple sensors can assist in visualizing the shape of the device and any bends in the path by providing a number of data points on the path (e.g., 8 sensors, spaced 1 mm apart) to create a 3D shape model of the device. Various

parameters can be used to track past or present movement and changes in device shape including, for example, elasticity, bend radius, limiting, and durometer rating of the device material. These parameters and accompanying data can provide visual cues to the user during the procedure, for example, when the device has a certain bend or curvature (based on path or surroundings), e.g., to provide a notice or warning that the device is on the correct or incorrect path, or to provide notice regarding, or track, a particular parameter(s) that the user is interested in. Such a sensor pathway is generally depicted in FIG. 18, which shows exemplary curvature warning scenarios in the differently marked sections or segments.

[0108] In various aspects and embodiments described herein, one can use the knowledge of the path traveled by the instrument and segmented airway or vessel from the acquired image (e.g., CT) to limit the possibilities of where the instrument is located in the patient. The techniques described herein, therefore, can be valuable to improve virtual displays for users. Fly through, Fly-above, or image displays related to segmented paths are commonly dependent upon relative closeness to the segmented path. For a breathing patient, for example, or a patient with a moving vessel related to heartbeat, it is valuable to use the path traveled information to determine where in the 4D patient motion cycle the system is located within the patient. By comparing the 3D location, the patient's tracked or physiological signal is used to determine 4D patient motion cycle, and with the instrument's traveled path, one can determine the optical location relative to a segmented airway or vessel and use this information to provide the optimal virtual display.

[0109] FIGS. 1 and 2 are schematic illustrations of devices that can be used in conjunction with, or to perform, various procedures described herein. As shown in FIG. 1, an apparatus 10 includes a PTD 20. The PTD 20 can be coupled to a dynamic body B. The dynamic body B can be, for example, a selected dynamic portion of the anatomy of a patient. The PTD 20 can be a variety of different shapes and sizes. For example, in one embodiment the PTD 20 is substantially planar, such as in the form of a patch that can be disposed at a variety of locations on a patient's body. Such a PTD 20 can be coupled to the dynamic body with adhesive, straps, hook and pile, snaps, or any other suitable coupling method. In another embodiment the PTD can be a catheter type device with a pigtail or anchoring mechanism that allows it to be attached to an internal organ or along a vessel.

[0110] Two or more markers or fiducials 22 are coupled to the PTD 20 at selected locations as shown in FIG. 1. The markers 22 are constructed of a material that can be viewed on an image, such as an X-ray or CT. The markers 22 can be, for example, radiopaque, and can be coupled to the PTD 20 using any known methods of coupling such devices. FIGS. 1 and 2 illustrate the apparatus 10 having four markers 22, but any number of two or more markers can be used. In one embodiment the marker or fiducials and the localization element can be the same device.

[0111] An imaging device 40 can be used to take images of the dynamic body B while the PTD 20 is coupled to the dynamic body B, pre-procedurally during a first time interval. As stated above, the markers 22 are visible on the images and can provide an indication of a position of each of the markers 22 during the first time interval. The position of the markers 22 at given instants in time through a path of motion of the dynamic body B can be illustrated with the images. The imaging device 40 can be, for example, a computed tomog-

raphy (CT) device (e.g., respiratory-gated CT device, ECG-gated CT device), a magnetic resonance imaging (MRI) device (e.g., respiratory-gated MRI device, ECG-gated MRI device), an X-ray device, or any other suitable medical imaging device. In one embodiment, the imaging device 40 is a computed tomography—positron emission tomography device that produces a fused computed tomography—positron emission tomography image dataset. The imaging device 40 can be in communication with a processor 30 and send, transfer, copy and/or provide image data taken during the first time interval associated with the dynamic body B to the processor 30.

[0112] The processor 30 includes a processor-readable medium storing code representing instructions to cause the processor 30 to perform a process. The processor 30 can be, for example, a commercially available personal computer, or a less complex computing or processing device that is dedicated to performing one or more specific tasks. For example, the processor 30 can be a terminal dedicated to providing an interactive graphical user interface (GUI). The processor 30, according to one or more embodiments of the invention, can be a commercially available microprocessor. Alternatively, the processor 30 can be an application-specific integrated circuit (ASIC) or a combination of ASICs, which are designed to achieve one or more specific functions, or enable one or more specific devices or applications. In yet another embodiment, the processor 30 can be an analog or digital circuit, or a combination of multiple circuits.

[0113] The processor 30 can include a memory component 32. The memory component 32 can include one or more types of memory. For example, the memory component 32 can include a read only memory (ROM) component and a random access memory (RAM) component. The memory component can also include other types of memory that are suitable for storing data in a form retrievable by the processor 30. For example, electronically programmable read only memory (EPROM), erasable electronically programmable read only memory (EEPROM), flash memory, as well as other suitable forms of memory can be included within the memory component. The processor 30 can also include a variety of other components, such as for example, coprocessors, graphic processors, etc., depending upon the desired functionality of the code.

[0114] The processor 30 can store data in the memory component 32 or retrieve data previously stored in the memory component 32. The components of the processor 30 can communicate with devices external to the processor 30 by way of an input/output (I/O) component (not shown). According to one or more embodiments of the invention, the I/O component can include a variety of suitable communication interfaces. For example, the I/O component can include, for example, wired connections, such as standard serial ports, parallel ports, universal serial bus (USB) ports, S-video ports, local area network (LAN) ports, small computer system interface (SCSI) ports, and so forth. Additionally, the I/O component can include, for example, wireless connections, such as infrared ports, optical ports, Bluetooth® wireless ports, wireless LAN ports, or the like.

[0115] The processor 30 can be connected to a network, which may be any form of interconnecting network including an intranet, such as a local or wide area network, or an extranet, such as the World Wide Web or the Internet. The network

can be physically implemented on a wireless or wired network, on leased or dedicated lines, including a virtual private network (VPN).

[0116] As stated above, the processor 30 can receive image data from the imaging device 40. The processor 30 can identify the position of selected markers 22 within the image data or voxel space using various segmentation techniques, such as Hounsfield unit thresholding, convolution, connected component, or other combinatory image processing and segmentation techniques. The processor 30 can determine a distance and direction between the position of any two markers 22 during multiple instants in time during the first time interval, and store the image data, as well as the position and distance data, within the memory component 32. Multiple images can be produced providing a visual image at multiple instants in time through the path of motion of the dynamic body. The processor 30 can also include a receiving device or localization device 34, which is described in more detail below.

[0117] A deformation field may also be included in the analysis in various embodiments described herein. For example, the deformation field can be applied to fuse 3D fluoroscopic images to CT images in order to compensate for different patient orientations, patient position, respiration, deformation induced by the catheter or other instrument, and/or other changes or perturbations that occur due to therapy delivery or resection or ablation of tissue.

[0118] In some embodiments, for example, real-time respiration compensation can be determined by applying an inspiration-to-expiration deformation vector field. In combination with the PTD respiratory signal, for example, the instrument location can be calculated using the deformation vector field. A real-time instrument tip correction vector can be applied to a 3D localized instrument tip. The real-time correction vector is computed by scaling an inspiration-to-expiration deformation vector (found from the inspiration-to-expiration deformation vector field) based on the PTD respiratory signal. This correction vector can then be applied to the 3D localized instrument tip. This can further optimize accuracy during navigation.

[0119] An example of an algorithm for real-time respiration compensation can be found in FIG. 19. In accordance with this algorithm, for each l:

[0120] (a) find v_i such that scalar d is minimized;

[0121] (b) compute c, wherein:

$$c = -v_i t$$

[0122] and (c) compute l', wherein:

$$l' = l + c$$

Thus, l' is a respiration compensated version of l.

[0123] Although FIG. 19 and the above discussion generally relate to real-time respiration motion, it will be understood that these calculations and determinations may also be applied to real-time heartbeat and/or vessel motion compensation, or any other motion of a dynamic body as described herein. In one embodiment, for example, the deformation matrix is calculated based upon inspiration and expiration. In another embodiment, for example, the deformation matrix is calculated based upon heartbeat. In yet another embodiment, for example, the deformation matrix is based upon vessel motion. In these and other embodiments, it is also possible to extend these calculations and determinations to develop multiple deformation matrices across multiple patient datasets, by acquiring the multiple datasets over the course of, for example, a single heartbeat cycle or a single respiratory cycle.

[0124] Deformation on 2D images can also be calculated based upon therapeutic change of tissue, changes in Hounsfield units for images, patient motion compensation during the imaging sequence, therapy monitoring, and temperature monitoring with fluoroscopic imaging, among other things. One potential issue with conventional therapy delivery, for instance, is monitoring the therapy for temperature or tissue changes. In accordance with the methods described herein, this monitoring can be carried out using intermittent fluoroscopic imaging, where the images are compensated between acquisition times to show very small changes in image density, which can represent temperature changes or tissue changes as a result of the therapy and/or navigation.

[0125] In general, it may also be preferable to reduce the level of radiation that patients are exposed to before or during a procedure (or pre-procedural analysis) as described herein. One method of reducing radiation during the acquisition of a 3D fluoroscopic dataset (or other dataset described herein), for example, is to use a deformation field between acquired 2D images to reduce the actual number of 2D images that need to be acquired to create the 3D dataset. In one particular embodiment, the deformation field is used to calculate the deformation between images in the acquisition sequence to produce 2D images between the acquired slices, and these new slices can be used to calculate the 3D fluoroscopic dataset. For example, if 180 2D image slices were previously required, e.g., an image(s) taken every 2 degrees of a 360 degree acquisition sequence, in accordance with some embodiments 90 2D images can be acquired over a 360 degree acquisition sequence and the data from the images that would have ordinarily been acquired between each slice can be calculated and imported into the 3D reconstruction algorithm. Thus, the radiation is effectively reduced by 50%.

[0126] As shown in FIG. 2, two or more localization elements 24 are coupled to the PTD 20 proximate the locations of the markers 22 for use during a medical procedure to be performed during a second time interval. The localization elements 24 can be, for example, electromagnetic coils, infrared light emitting diodes, and/or optical passive reflective markers. The localization elements 24 can also be, or be integrated with, one or more fiber optic localization (FDL) devices. The markers 22 can include plastic or non-ferrous fixtures or dovetails or other suitable connectors used to couple the localization elements 24 to the markers 22. A medical procedure can then be performed with the PTD 20 coupled to the dynamic body B at the same location as during the first time interval when the pre-procedural images were taken. During the medical procedure, the localization elements 24 are in communication or coupled to the localization device 34 included within processor 30. The localization device 34 can be, for example, an analog to digital converter that measures voltages induced onto localization coils in the field; creates a digital voltage reading; and maps that voltage reading to a metric positional measurement based on a characterized volume of voltages to millimeters from a fixed field emitter. Position data associated with the elements 24 can be transmitted or sent to the localization device 34 continuously during the medical procedure during the second time interval. Thus, the position of the localization elements 24 can be captured at given instants in time during the second time interval. Because the localization elements 24 are coupled to the PTD 20 proximate the markers 22, the localization device 34 can use the position data of the elements 24 to deduce coordinates or positions associated with the markers 22 intra-

procedurally during the second time interval. The distance, range, acceleration, and speed between one or more selected pairs of localization elements 24 (and corresponding markers 22) can then be determined and various algorithms can be used to analyze and compare the distance between selected elements 24 at given instants in time, to the distances between and orientation among corresponding markers 22 observed in the pre-operative images.

[0127] An image can then be selected from the pre-operative images taken during the first time interval that indicates a distance or is grouped in a similar sequence of motion between corresponding markers 22 at a given instant in time, that most closely approximates or matches the distance or similar sequence of motion between the selected elements 24. The process of comparing the distances is described in more detail below. Thus, the apparatus 10 and processor 30 can be used to provide images corresponding to the actual movement of the targeted anatomy during the medical procedure being performed during the second time interval. The images illustrate the orientation and shape of the targeted anatomy during a path of motion of the anatomy, for example, during inhaling and exhaling.

[0128] FIG. 3 illustrates an example set of distances or vectors d1 through d6 between a set of markers 122, labeled m1 through m9 that are disposed at spaced locations on a PTD 120. As described above, pre-procedure images can be taken of a dynamic body for which the PTD 120 is to be coupled during a first time interval. The distances between the markers can be determined for multiple instants in time through the path of motion of the dynamic body. Then, during a medical procedure, performed during a second time interval, localization elements (not shown in FIG. 3) coupled proximate to the location of markers 122 can provide position data for the elements to a localization device (not shown in FIG. 3). The localization device can use the position data to determine distances or vectors between the elements for multiple instants in time during the medical procedure or second time interval.

[0129] FIG. 4A shows an example of distance or vector data from the localization device. Vectors a1 through a6 represent distance data for one instant in time and vectors n1 through n6 for another instant in time, during a time interval from a to n. As previously described, the vector data can be used to select an image from the pre-procedural images that includes distances between the markers m1 through m9 that correspond to or closely approximate the distances a1 through a6 for time a, for example, between the localization elements. The same process can be performed for the vectors n1 through n6 captured during time n.

[0130] One method of selecting the appropriate image from the pre-procedural images is to execute an algorithm that can sum all of the distances a1 through a6 and then search for and match this sum to an image containing a sum of all of the distances d1 through d6 obtained pre-procedurally from the image data that is equal to the sum of the distances a1 through a6. When the difference between these sums is equal to zero, the relative position and orientation of the anatomy or dynamic body D during the medical procedure will substantially match the position and orientation of the anatomy in the particular image. The image associated with distances d1 through d6 that match or closely approximate the distances a1 through a6 can then be selected and displayed. For example, FIG. 4B illustrates examples of pre-procedural images, Image a and Image n, of a dynamic body D that correspond to

the distances a1 through a6 and n1 through n6, respectively. An example of an algorithm for determining a match is as follows:

[0131] Does $\sum a_i = \sum d_i$ (i=1 to 6 in this example) OR

[0132] Does $\sum (a_i - d_i) = 0$ (i=1 to 6 in this example).

If yes to either of these, then the image is a match to the vector or distance data obtained during the medical procedure.

[0133] FIG. 5 illustrates an apparatus 210 according to an embodiment of the invention. The apparatus 210 includes a tubular shaped PTD 220 that can be constructed with a rigid material or, alternatively, a flexible and/or stretchable material. In one embodiment, for example, the PTD 220 is substantially rigid in structure. In another embodiment, for example, the PTD 220 has a flexible or stretchable structure. The PTD 220 can be positioned over a portion of a patient's body, such as around the upper or lower torso of the patient. In the embodiments in which the PTD 220 is constructed with a stretchable and/or flexible material, for instance, the stretchability of the PTD 220 allows the PTD 220 to at least partially constrict some of the movement of the portion of the body for which it is coupled. The apparatus 210 further includes multiple markers or fiducials 222 coupled to the PTD 220 at spaced locations. A plurality of localization elements 224 are removably coupled proximate to the locations of markers 222, such that during a first time interval as described above, images can be taken without the elements 224 being coupled to the PTD 220. The localization elements need not be removably coupled. For example, the elements can be fixedly coupled to the PTD. In addition, the elements can be coupled to the PTD during the pre-procedure imaging.

[0134] FIG. 6 is a graphical illustration indicating how the apparatus 210 (shown without localization elements 224) can move and change orientation and shape during movement of a dynamic body, such as a mammalian body M. The graph is one example of how the lung volume can change during inhalation (inspiration) and exhalation (expiration) of the mammalian body M. The corresponding changes in shape and orientation of the apparatus 210 during inhalation and exhalation are also illustrated. The six markers 222 shown in FIG. 5 are labeled a, b, c, d, e, and f. As described above, images of the apparatus 110 can be taken during a first time interval. The images can include an indication of relative position of each of the markers 222, that is the markers 222 are visible in the images, and the position of each marker 222 can then be observed over a period of time. A distance between any two markers 222 can then be determined for any given instant of time during the first time interval. For example, a distance X between markers a and b is illustrated, and a distance Y between markers b and f is illustrated. These distances can be determined for any given instant in time during the first time interval from an associated image that illustrates the position and orientation of the markers 222. As illustrated, during expiration of the mammalian body M at times indicated as A and C, the distance X is smaller than during inspiration of the mammalian body M, at the time indicated as B. Likewise, the distance Y is greater during inspiration than during expiration. The distance between any pair of markers 222 can be determined and used in the processes described herein. Thus, the above embodiments are merely examples of possible pair selections. For example, a distance between a position of marker e and a position of marker b may be determined. In addition, multiple pairs or only one pair may be selected for a given procedure.

[0135] FIG. 7 is a flowchart illustrating a method according to an embodiment of the invention. A method 50 includes at step 52 receiving image data during a pre-procedural or first time interval. As discussed above, images are taken of a dynamic body using an appropriate imaging modality (e.g., CT Scan, MRI, etc.). The image data is associated with one or more images taken of a PTD (as described herein) coupled to a dynamic body, where the PTD includes two or more markers coupled thereto. In other words, the image data of the dynamic body is correlated with image data related to the PTD. The one or more images can be taken using a variety of different imaging modalities as described previously. The image data can include an indication of a position of a first marker and an indication of a position of a second marker, as illustrated at step 54. The image data can include position data for multiple positions of the markers during a range or path of motion of the dynamic body over a selected time interval. As described above, the image data can include position data associated with multiple markers, however, only two are described here for simplicity. A distance between the position of the first marker and the position of the second marker can be determined for multiple instants in time during the first time interval, at step 56. As also described above, the determination can include determining the distance based on the observable distance between the markers on a given image. The image data, including all of the images received during the first time interval, the position, and the distance data can be stored in a memory and/or recorded at step 58.

[0136] Then at step 60, during a second time interval, while performing a medical procedure on the patient with the PTD positioned on the patient at substantially the same location, position data can be received for a first localization element and a second localization element. The localization elements can be coupled to the PTD proximate the locations of the markers, such that the position data associated with the elements can be used to determine the relative position of the markers in real-time during the medical procedure. The position data of the elements can be stored and/or recorded at step 62.

[0137] A distance between the first and second localization elements can be determined at step 64. Although only two localization elements are described, as with the markers, position data associated with more than two localization elements can be received and the distances between the additional elements can be determined.

[0138] The next step is to determine which image from the one or more images taken during the first time interval represents the relative position and/or orientation of the dynamic body at a given instant in time during the second time interval or during the medical procedure. To determine this, at step 66, the distance between the positions of the first and second localization elements at a given instant in time during the second time interval are compared to the distance(s) determined in step 56 between the positions of the first and second markers obtained with the image data during the first time interval.

[0139] An image can be selected from the first time interval that best represents the same position and orientation of the dynamic body at a given instant in time during the medical procedure. To do this, the difference between the distance between a given pair of localization elements during the second time interval is used to select the image that contains the same distance between the same given pair of markers from the image data received during the first time interval. This can

be accomplished, for example, by executing an algorithm to perform the calculations. When there are multiple pairs of markers and localization elements, the algorithm can sum the distances between all of the selected pairs of elements for a given instant in time during the second time interval and sum the distances between all of the associated selected pairs of markers for each instant in time during the first time interval when the pre-procedural image data was received.

[0140] When an image is found that provides the sum of distances for the selected pairs of markers that is substantially the same as the sum of the distances between the localization elements during the second time interval, then that image is selected at step 68. The selected image can then be displayed at step 70. The physician can then observe the image during the medical procedure on a targeted portion of the dynamic body. Thus, during the medical procedure, the above process can be continuously executed such that multiple images are displayed and images corresponding to real-time positions of the dynamic body can be viewed.

[0141] FIG. 8 shows one embodiment of a system (system 100) that includes components that can be used to perform image guided interventions using a gated imaging modality, such as ECG-gated MRI, or ECG-gated CT. The figure depicts a patient 10 positioned on an operating table 12 with a physician 14 performing a medical procedure on him.

[0142] Specifically, FIG. 8 depicts physician 14 steering a medical instrument 16 through the patient's internal anatomy in order to deliver therapy. In this particular instance, instrument 16 is depicted as a catheter entering the right atrium by way of the inferior vena cava preceded by a femoral artery access point; however, the present systems are not limited to catheter use indications. The position of virtually any instrument may be tracked as discussed below and a representation of it superimposed on the proper image, consistent with the present methods, apparatuses, and systems. An "instrument" is any device controlled by physician 10 for the purpose of delivering therapy, and includes needles, guidewires, stents, filters, occluders, retrieval devices, imaging devices (such as OCT, EBUS, IVUS, and the like), and leads. Instrument 16 is fitted with one or more instrument reference markers 18. A tracker 20 (which is sometimes referred to in the art as a "tracking system") is configured to track the type of reference marker or markers coupled to instrument 16. Tracker 20 can be any type of tracking system, including but not limited to an electromagnetic tracking system. An example of a suitable electromagnetic tracking system is the AURORA electromagnetic tracking system, commercially available from Northern Digital Inc. in Waterloo, Ontario Canada. If tracker 20 is an electromagnetic tracking system, element 20 would represent an electromagnetic field generator that emits a series of electromagnetic fields designed to engulf patient 10, and reference marker or markers 18 coupled to medical instrument 16 could be coils that would receive an induced voltage that could be monitored and translated into a coordinate position of the marker(s).

[0143] As noted herein, a variety of instruments and devices can be used in conjunction with the systems and methods described herein. In one embodiment, for example, an angled coil sensor is employed during the targeted navigation. In accordance with this embodiment, for example, instead of using a conventional wire sensor wrapped at about a 90° angle (i.e., roughly perpendicular) to the axial length (or core) of the sensor, the coil is wrapped at an acute angle (i.e., the angle is less than about 90°) relative to the axial length of

the sensor. In one embodiment, the coil is positioned (e.g., wrapped) at an angle of from about 30° to about 60° relative to the axial length. In one preferred embodiment, the coil is positioned at about a 45° angle relative to the axial length. The positioning of the coil in accordance with the exemplary embodiments described herein advantageously provides a directional vector that is not parallel with the sensor core. Thus, the physical axis is different and, as the sensor moves, this additional directional vector can be quantified and used to detect up and down (and other directional) movement. This motion can be captured over time as described herein to determine orientation and prepare and display the more accurate images.

[0144] An external reference marker 22 can be placed in a location close to the region of the patient where the procedure is to be performed, yet in a stable location that will not move (or that will move a negligible amount) with the patient's heart beat and respiration. If patient 10 is securely fixed to table 12 for the procedure, external reference marker 22 (which may be described as "static") can be affixed to table 12. If patient 10 is not completely secured to table 12, external reference marker 22 can be placed on region of the back of patient 10 exhibiting the least amount of movement. Tracker 20 can be configured to track external reference marker 22.

[0145] One or more non-tissue internal reference markers 24 can be placed in the gross region where the image guided navigation will be carried out. Non-tissue internal reference marker(s) 24 should be placed in an anatomic location that exhibits movement that is correlated with the movement of the anatomy intended for image guided navigation. This location will be internal to the patient, in the gross location of the anatomy of interest.

[0146] Medical instrument 16, instrument reference marker(s) 18, external reference marker 22, and non-tissue internal reference marker(s) 24 can be coupled to converter 26 of system 100. Converter 26, one example of which may be referred to in the art as a break-out box, can be configured to convert analog measurements received from the reference markers and tracker 20 into digital data understandable by image guidance computing platform 30, and relay that data to image guidance computing platform 30 to which converter 26 can be coupled. Image guidance computing platform 30 can take the form of a computer, and may include a monitor on which a representation of one or more instruments used during the IGI can be displayed over an image of the anatomy of interest.

[0147] System 100 also includes a periodic human characteristic signal monitor, such as ECG monitor 32, which can be configured to receive a periodic human characteristic signal. For example, ECG monitor 32 can be configured to receive an ECG signal in the form of the ECG data transmitted to it by ECG leads 34 coupled to patient 10. The periodic human characteristic signal monitor (e.g., ECG monitor 32) can also be configured to relay a periodic human characteristic signal (e.g., ECG data) to image guidance computing platform 30, to which it can be coupled.

[0148] Prior to the start of the image guided intervention, non-tissue internal reference marker(s) 24—but not necessarily static external reference marker 22—should be placed in the gross region of interest for the procedure. After placement of non-tissue internal reference marker(s) 24, patient 10 is to be scanned with an imaging device, such as gated scanner 40, and the resulting gated image dataset transferred to image guidance computing platform 30, to which the imaging

device is coupled and which can reside in the operating or procedure theatre. Examples of suitable imaging devices, and more specifically suitable gated scanners, include ECG-gated MRI scanners and ECG-gated CT scanners. A hospital network **50** may be used to couple gated scanner **40** to image guidance computing platform **30**.

[0149] The imaging device (e.g., gated scanner **40**) can be configured to create a gated dataset that includes pre-operative images, one or more of which (up to all) are taken using the imaging device and are linked to a sample of a periodic human characteristic signal (e.g., a sample, or a phase, of an ECG signal). Once patient **10** is scanned using the imaging device and the gated dataset is transferred to and received by image guidance computing platform **30**, patient **10** can be secured to operating table **12** and the equipment making up system **100** (e.g., tracker **20**, converter **26**, image guidance computing platform **30**, ECG monitor **32**, and gated scanner **40**) set up as shown in FIG. **9**. Information can then flow among the system **100** components.

[0150] At this point, a gated dataset created by gated scanner **40** resides on image guidance computing platform **30**. FIG. **9** highlights the relationship between the samples (S1 . . . Sn) and the images (I1 . . . In) that were captured by gated scanner **40**. Designations P, Q, R, S, and T are designations well known in the art; they designate depolarizations and re-polarizations of the heart. Gated scanner **40** essentially creates an image of the anatomy of interest at a particular instant in time during the anatomy's periodic movement. Image I1 corresponds to the image that was captured at the S1 moment of patient **10**'s ECG cycle. Similarly, I2 is correlated with S2, and In with Sn.

[0151] FIG. **10** is a diagram of another exemplary surgical instrument navigation system **10**. In accordance with one aspect of the present invention, the surgical instrument navigation system **10** is operable to visually simulate a virtual volumetric scene within the body of a patient, such as an internal body cavity, from a point of view of a surgical instrument **12** residing in the cavity of a patient **13**. To do so, the surgical instrument navigation system **10** is primarily comprised of a surgical instrument **12**, a data processor **16** having a display **18**, and a tracking subsystem **20**. The surgical instrument navigation system **10** may further include (or accompanied by) an imaging device **14** that is operable to provide image data to the system.

[0152] The surgical instrument **12** is preferably a relatively inexpensive, flexible and/or steerable catheter that may be of a disposable type. The surgical instrument **12** is modified to include one or more tracking sensors that are detectable by the tracking subsystem **20**. It is readily understood that other types of surgical instruments (e.g., a guide wire, a needle, a forcep, a pointer probe, a stent, a seed, an implant, an endoscope, an energy delivery device, a therapy delivery device, etc.) are also within the scope of the present invention. It is also envisioned that at least some of these surgical instruments may be wireless or have wireless communications links. It is also envisioned that the surgical instruments may encompass medical devices which are used for exploratory purposes, testing purposes or other types of medical procedures.

[0153] The volumetric scan data is then registered as shown at **34**. Registration of the dynamic reference frame **19** generally relates information in the volumetric scan data to the region of interest associated with the patient. This process is referred to as registering image space to patient space. Often,

the image space must also be registered to another image space. Registration is accomplished through knowledge of the coordinate vectors of at least three non-collinear points in the image space and the patient space.

[0154] Referring to FIG. **11**, the imaging device **14** is used to capture volumetric scan data **32** representative of an internal region of interest within the patient **13**. The three-dimensional scan data is preferably obtained prior to surgery on the patient **13**. In this case, the captured volumetric scan data may be stored in a data store associated with the data processor **16** for subsequent processing. However, one skilled in the art will readily recognize that the principles of the present invention may also extend to scan data acquired during surgery. It is readily understood that volumetric scan data may be acquired using various known medical imaging devices **14**, including but not limited to a magnetic resonance imaging (MRI) device, a computed tomography (CT) imaging device, a positron emission tomography (PET) imaging device, a 2D or 3D fluoroscopic imaging device, and 2D, 3D or 4D ultrasound imaging devices. In the case of a two-dimensional ultrasound imaging device or other two-dimensional image acquisition device, a series of two-dimensional data sets may be acquired and then assembled into volumetric data as is well known in the art using a two-dimensional to three-dimensional conversion.

[0155] The multi-dimensional imaging modalities described herein may also be coupled with digitally reconstructed radiography (DRR) techniques. In accordance with a fluoroscopic image acquisition, for example, radiation passes through a physical media to create a projection image on a radiation-sensitive film or an electronic image intensifier. Given a 3D or 4D dataset as described herein, for example, a simulated image can be generated in conjunction with DRR methodologies. DRR is generally known in the art, and is described, for example, by Lemieux et al. (Med. Phys. 21(11), November 1994, pp. 1749-60).

[0156] When a DRR image is created, a fluoroscopic image is formed by computationally projecting volume elements, or voxels, of the 3D or 4D dataset onto one or more selected image planes. Using a 3D or 4D dataset of a given patient as described herein, for example, it is possible to generate a DRR image that is similar in appearance to a corresponding patient image. This similarity can be due, at least in part, to similar intrinsic imaging parameters (e.g., projective transformations, distortion corrections, etc.) and extrinsic imaging parameters (e.g., orientation, view direction, etc.). The intrinsic imaging parameters can be derived, for instance, from the calibration of the equipment. Advantageously, this provides another method to see the up-and-down (and other directional) movement of the instrument. This arrangement further provides the ability to see how the device moves in an image (s), which translates to improved movement of the device in a patient. An exemplary pathway in accordance with the disclosure herein can be seen in FIG. **17**.

[0157] A dynamic reference frame **19** is attached to the patient proximate to the region of interest within the patient **13**. To the extent that the region of interest is a vessel or a cavity within the patient, it is readily understood that the dynamic reference frame **19** may be placed within the patient **13**. To determine its location, the dynamic reference frame **19** is also modified to include tracking sensors detectable by the tracking subsystem **20**. The tracking subsystem **20** is operable to determine position data for the dynamic reference frame **19** as further described below.

[0158] The volumetric scan data is then registered as shown at 34. Registration of the dynamic reference frame 19 generally relates information in the volumetric scan data to the region of interest associated with the patient. This process is referred to as registering image space to patient space. Often, the image space must also be registered to another image space. Registration is accomplished through knowledge of the coordinate vectors of at least three non-collinear points in the image space and the patient space.

[0159] Registration for image guided surgery can be completed by different known techniques. First, point-to-point registration is accomplished by identifying points in an image space and then touching the same points in patient space. These points are generally anatomical landmarks that are easily identifiable on the patient. Second, surface registration involves the user's generation of a surface in patient space by either selecting multiple points or scanning, and then accepting the best fit to that surface in image space by iteratively calculating with the data processor until a surface match is identified. Third, repeat fixation devices entail the user repeatedly removing and replacing a device (i.e., dynamic reference frame, etc.) in known relation to the patient or image fiducials of the patient. Fourth, automatic registration by first attaching the dynamic reference frame to the patient prior to acquiring image data. It is envisioned that other known registration procedures are also within the scope of the present invention, such as that disclosed in U.S. Ser. No. 09/274,972, filed on Mar. 23, 1999, entitled "NAVIGATIONAL GUIDANCE VIA COMPUTER-ASSISTED FLUOROSCOPIC IMAGING", which is hereby incorporated by reference.

[0160] FIG. 12 illustrates another type of secondary image 28 which may be displayed in conjunction with the primary perspective image 38. In this instance, the primary perspective image is an interior view of an air passage within the patient 13. The secondary image 28 is an exterior view of the air passage which includes an indicia or graphical representation 29 that corresponds to the location of the surgical instrument 12 within the air passage. In FIG. 12, the indicia 29 is shown as a crosshairs. It is envisioned that other indicia may be used to signify the location of the surgical instrument in the secondary image. As further described below, the secondary image 28 is constructed by superimposing the indicia 29 of the surgical instrument 12 onto the manipulated image data 38.

[0161] Referring to FIG. 13, the display of an indicia of the surgical instrument 12 on the secondary image may be synchronized with an anatomical function, such as the cardiac or respiratory cycle, of the patient. In certain instances, the cardiac or respiratory cycle of the patient may cause the surgical instrument 12 to flutter or jitter within the patient. For instance, a surgical instrument 12 positioned in or near a chamber of the heart will move in relation to the patient's heart beat. In these instance, the indicia of the surgical instrument 12 will likewise flutter or jitter on the displayed image 40. It is envisioned that other anatomical functions which may effect the position of the surgical instrument 12 within the patient are also within the scope of the present invention.

[0162] To eliminate the flutter of the indicia on the displayed image 40, position data for the surgical instrument 12 is acquired at a repetitive point within each cycle of either the cardiac cycle or the respiratory cycle of the patient. As described above, the imaging device 14 is used to capture volumetric scan data 42 representative of an internal region of

interest within a given patient. A secondary image may then be rendered 44 from the volumetric scan data by the data processor 16.

[0163] In order to synchronize the acquisition of position data for the surgical instrument 12, the surgical instrument navigation system 10 may further include a timing signal generator 26. The timing signal generator 26 is operable to generate and transmit a timing signal 46 that correlates to at least one of (or both) the cardiac cycle or the respiratory cycle of the patient 13. For a patient having a consistent rhythmic cycle, the timing signal might be in the form of a periodic clock signal. Alternatively, the timing signal may be derived from an electrocardiogram signal from the patient 13. One skilled in the art will readily recognize other techniques for deriving a timing signal that correlate to at least one of the cardiac or respiratory cycle or other anatomical cycle of the patient.

[0164] As described above, the indicia of the surgical instrument 12 tracks the movement of the surgical instrument 12 as it is moved by the surgeon within the patient 13. Rather than display the indicia of the surgical instrument 12 on a real-time basis, the display of the indicia of the surgical instrument 12 is periodically updated 48 based on the timing signal from the timing signal generator 26. In one exemplary embodiment, the timing generator 26 is electrically connected to the tracking subsystem 20. The tracking subsystem 20 is in turn operable to report position data for the surgical instrument 12 in response to a timing signal received from the timing signal generator 26. The position of the indicia of the surgical instrument 12 is then updated 50 on the display of the image data. It is readily understood that other techniques for synchronizing the display of an indicia of the surgical instrument 12 based on the timing signal are within the scope of the present invention, thereby eliminating any flutter or jitter which may appear on the displayed image 52. It is also envisioned that a path (or projected path) of the surgical instrument 12 may also be illustrated on the displayed image data 52.

[0165] In another aspect of the present invention, the surgical instrument navigation system 10 may be further adapted to display four-dimensional image data for a region of interest as shown in FIG. 14. In this case, the imaging device 14 is operable to capture volumetric scan data 62 for an internal region of interest over a period of time, such that the region of interest includes motion that is caused by either the cardiac cycle or the respiratory cycle of the patient 13. A volumetric perspective view of the region may be rendered 64 from the volumetric scan data 62 by the data processor 16 as described above. The four-dimensional image data may be further supplemented with other patient data, such as temperature or blood pressure, using coloring coding techniques.

[0166] In order to synchronize the display of the volumetric perspective view in real-time with the cardiac or respiratory cycle of the patient, the data processor 16 is adapted to receive a timing signal from the timing signal generator 26. As described above, the timing signal generator 26 is operable to generate and transmit a timing signal that correlates to either the cardiac cycle or the respiratory cycle of the patient 13. In this way, the volumetric perspective image may be synchronized 66 with the cardiac or respiratory cycle of the patient 13. The synchronized image 66 is then displayed 68 on the display 18 of the system. The four-dimensional synchronized image may be either (or both of) the primary image rendered from the point of view of the surgical instrument or the

secondary image depicting the indicia of the position of the surgical instrument **12** within the patient **13**. It is readily understood that the synchronization process is also applicable to two-dimensional image data acquire over time.

[0167] To enhance visualization and refine accuracy of the displayed image data, the surgical navigation system can use prior knowledge such as the segmented vessel or airway structure to compensate for error in the tracking subsystem or for inaccuracies caused by an anatomical shift occurring since acquisition of scan data. For instance, it is known that the surgical instrument **12** being localized is located within a given vessel or airway and, therefore should be displayed within the vessel or airway. Statistical methods can be used to determine the most likely location; within the vessel or airway with respect to the reported location and then compensate so the display accurately represents the instrument **12** within the center of the vessel or airway. The center of the vessel or airway can be found by segmenting the vessels or airways from the three-dimensional datasets and using commonly known imaging techniques to define the centerline of the vessel or airway tree. Statistical methods may also be used to determine if the surgical instrument **12** has potentially punctured the vessel or airway. This can be done by determining the reported location is too far from the centerline or the trajectory of the path traveled is greater than a certain angle (worse case 90 degrees) with respect to the vessel or airway. Reporting this type of trajectory (error) is very important to the clinicians. The tracking along the center of the vessel may also be further refined by correcting for motion of the respiratory or cardiac cycle, as described above. While navigating along the vessel or airway tree prior knowledge about the last known location can be used to aid in determining the new location. The instrument or navigated device must follow a pre-defined vessel or airway tree and therefore can not jump from one branch to the other without traveling along a path that would be allowed. The orientation of the instrument or navigated device can also be used to select the most likely pathway that is being traversed. The orientation information can be used to increase the probability or weight for selected location or to exclude potential pathways and therefore enhance system accuracy.

[0168] The surgical instrument navigation system of the present invention may also incorporate atlas maps. It is envisioned that three-dimensional or four-dimensional atlas maps may be registered with patient specific scan data or generic anatomical models. Atlas maps may contain kinematic information (e.g., heart and lung models) that can be synchronized with four-dimensional image data, thereby supplementing the real-time information. In addition, the kinematic information may be combined with localization information from several instruments to provide a complete four-dimensional model of organ motion. The atlas maps may also be used to localize bones or soft tissue which can assist in determining placement and location of implants.

[0169] FIG. **20**, for example, illustrates in one exemplary embodiment the use of Inspiration/arms-up CT and Expiration/arms-down CT for image guided navigation purposes. Stage (A) shows an Inspiration/arms-up pathway registration; this is, generally speaking, the preferred CT scan acquisition state for automatic segmentation of the tracheo-bronchial tree. Stage (B), on the other hand, shows FRC/arms-down segmentation (wherein FRC refers to the Functional Residual Capacity (i.e., the lung volume at the end of a normal expiration, when the muscles of respiration are completely

relaxed; at FRC (and typically at FRC only), the tendency of the lungs to collapse is exactly balanced by the tendency of the chest wall to expand). FRC/arms-down is, generally, the preferred navigational state for image guided pulmonary navigation. Unfortunately, however, using the inspiration (arms-up) state of the lungs for navigation can contribute significant error to the image guided navigation. Thus, in accordance with various embodiments described herein, the airways are segmented using full inspiration/arms-up CT acquisition, and mapped to a less-fully segmented, FRC/arms-down CT acquisition. As shown, the results can then be conformed to produce a fully segmented, tracheo-bronchial tree, at the proper spatial representation for patient FRC (Stage (C)).

[0170] FIG. **21** depicts a CT minP/maxP volume reading including a scenario whereby precise navigation (e.g., using an EM sensor) near a target lesion is carried out with incomplete segmentation results. This scenario provides the user with a view or image **1600** using minP (minimum intensity projection or maxP (maximum intensity projection) volume renderings to simultaneously integrate one or more of: (i) the last known segmented airway **1601**; (ii) the target(s) **1602**; (iii) a visually distinct representation of previously traversed paths that are "bad" (i.e., incorrect) **1603**; (iv) the distance and angle **1604** to the target (e.g., a target lesion) using a vector fit to the last 1 cm (or so) of travel (in addition to, or in place of, instantaneous orientation provided by a 5DOF tip sensor as described herein); and (v) to incorporate user provided "way points" to create a final-approach tube **1605** to the target. As described herein, the image **1600** may also provide a real-time or simulated real-time rendering of the device **1606** (e.g., the device tip as shown with a virtual extension **1607** to the target).

[0171] Referring now to FIGS. **22A** and **22B**, one exemplary embodiment of a 4D thoracic registration is depicted. In general, the 4D dataset may be acquired through respiratory gating or tracheal temporal registration. In accordance with the methods described herein, for example, acceleration of N data collectors (e.g., magnetic or MEMS accelerometers, for instance) are measured to register the thorax in time and space, using the general formula: $\text{data}_{T_{\text{thorax}}} = F(t)$. As shown in FIGS. **22A** and **22B**, the various sensors **1701** and tracheal sensor **1702** provide data as described herein, as does sternum sensor **1703** (e.g., x, y, and z dynamic tracking). Device **1704** (e.g., biopsy needle or other device or instrument described herein) is further capable of tracking position and trajectory (as described herein).

[0172] An exemplary apparatus and method for respiratory 4D data acquisition and navigation is depicted in FIG. **23**. As shown in the upper box, a respiratory problem or issue is scanned (e.g., by a CT and/or MR scanner) and signal S from the PTD is provide to the CT/IR unit (lower box). The 4D registration based on the motion of the fiducial and tracker units (which could be, e.g., EM sensors, MEMS devices, combinations thereof, and the like) is provided to the user (shown in FIG. **18** as an interventional radiologist (IR)) on computer C. The system is capable of displaying the current position of the device tip in the image data shown to the IR, using the fiducial or tracker locations in the scan coupled with the real-time motion information provided by the device tip (e.g., which can include a sensor as described herein), thus providing registration.

[0173] A representative offset device in accordance in certain embodiments of the disclosure herein is depicted in

FIGS. 24A and 24B, which show a scope or other instrument 1500 including one or more offset devices 1501 at port 1502. The offset device(s) is/are capable of holding the tracked guidewire 1503 (including brush 1504 at the scope tip) in place and provide a substantially fixed distance or length of extension out of the scope (or virtual scope) to take a sample. It will be understood that brush 1504 at the guidewire tip may be any of a variety of devices, including forceps, needles (e.g., a biopsy needle), and the like. As shown, multiple offsets 1501 can be provided in stages that allow extension of the guidewire, e.g., at 1 cm, 2 cm, 3 cm, and so on, whereby the user can adjust the offsets by removal or repositioning (removed offsets 1501R, for example, are depicted in dashed lines within the port in FIG. 15B). Thus, FIG. 24A shows the brush tip 1504 at the tip of the scope (i.e., prior to extension), whereas FIG. 24B shows the guidewire and tip extended (e.g., 2 cm of extension) by the removal or repositioning of two offsets 1501R.

[0174] In FIG. 25 a representative actuatable sensor/forceps device in accordance with the embodiments described herein is depicted. As shown, the coil of an EM (or other) sensor 1601 disposed in a catheter (or similar device) body 1600 can act as a solenoid to actuate a forceps 1602. In accordance with the illustrated embodiment, for example, the solenoid coil is used as an EM sensor in a "passive" mode, but can be activated by energy stored in an ultra-capacitor 1603 which actuates the forceps via armature 1604 in an "active" mode.

CONCLUSION

[0175] While various embodiments of the invention have been described above, it should be understood that they have been presented by way of example only, and not limitation. Thus, the breadth and scope of the invention should not be limited by any of the above-described embodiments, but should be defined only in accordance with the following claims and their equivalents.

[0176] The previous description of the embodiments is provided to enable any person skilled in the art to make or use the invention. While the invention has been particularly shown and described with reference to embodiments thereof, it will be understood by those skilled in art that various changes in form and details may be made therein without departing from the spirit and scope of the invention. For example, the PTD, markers and localization elements can be constructed from any suitable material, and can be a variety of different shapes and sizes, not necessarily specifically illustrated, while still remaining within the scope of the invention.

1. An image-guided method comprising directing an endoscope including a tip sensor to an anatomical position in a patient;

orienting an endoscopic view to a visual orientation of a user;

activating a steering mechanism of the endoscope to agitate the tip sensor in a plane; and

determining the orientation and location of the tip sensor in the patient and correlating the tip sensor location and orientation with one or more patient images.

2. The image-guided method of claim 1 wherein the anatomical position is a branching point of a bronchial tree.

3. The image-guided method of claim 1, wherein the tip sensor is an angled coil sensor, the coil being disposed at a 45° angle relative to a core portion of the tip sensor.

4. The image-guided method of claim 1, wherein orientation and location determination comprise applying a deformation vector field.

5. The image-guided method of claim 1, wherein the one or more patient images are derived from an imaging device in conjunction with a patient tracking device disposed at an external region of the patient.

6. A method of using a guidewire or other navigated instrument with one to one rotation to continuously align a virtual display view to be consistent with an actual bronchoscopic video view.

7. A method of using a video input of the bronchoscope to adjust the virtual fly-through view to be consistent with a user's normal perspective.

8. The method of claim 7 wherein video processing and matching techniques can be used between the real-time video and the virtual image to align.

9. A method of using bronchoscopic video to provide angular information at a current location to provide targeting or directional cues to the user.

10. The method of claim 9 wherein the angular information is derived from the location of patient anatomy in the image and the relative size of each within the image.

11. A system or apparatus comprising one or more components for carrying out one or more elements of the method of claim 7.

12. A non-transitory processor-readable medium storing code representing instructions to cause a processor to perform a process, the code comprising code to carry out one or more elements of the method of claim 7.

13. An imaging method comprising tracking the traveled path of an instrument in a patient and correlating the tracked path with one or more sets of image data derived from an imaging device in conjunction with a patient tracking device.

14. The method of claim 13 wherein a respiratory signal or a heartbeat signal derived from the patient tracking device is used to gate localization data of the instrument in an anatomical position of the patient to determine on or more patient airway models and correlate the instrument position to the image data to provide a registration of the one or more patient airway models during a respiratory cycle of the patient.

15. The method of claim 13 wherein the patient airway model determination comprises the addition of patient airway data to the image data.

16. The method of claim 15 wherein the patient airway data comprises branching points or segments of branching points in a bronchial tree.

17. The method of claim 13, wherein the correlation of the tracked path comprises applying a deformation vector field.

18. A system or apparatus comprising one or more components for carrying out one or more elements of the method of claim 13.

19. A non-transitory processor-readable medium storing code representing instructions to cause a processor to perform a process, the code comprising code to carry out one or more elements of the method of claim 13.

20. An endoscope or attachment thereof including one or more offset devices proximate a port of the endoscope or attachment, the offset devices capable of securing a navigated guidewire in a predetermined location.

21. The endoscope or attachment of claim 20 wherein a guidewire of the endoscope comprises one or more detachable sensors on a fiducial structure.

22. The endoscope or attachment of claim **20** wherein the endoscope comprises a sensor affixed proximate to an aspiration needle disposed at an end of the endoscope or attachment, wherein the needle tip and the sensor move in conjunction with one another upon actuation of the endoscope by a user.

23. The endoscope or attachment of claim **20** wherein the endoscope comprises a sensor affixed proximate to a brush disposed at an end of the endoscope or attachment, wherein the brush and the sensor move in conjunction with one another upon actuation of the endoscope by a user.

24. The endoscope or attachment of claim **20** wherein the endoscope comprises a sensor affixed proximate to a forceps disposed at an end of the endoscope or attachment, wherein the forceps and the sensor move in conjunction with one another upon actuation of the endoscope by a user.

25. The endoscope or attachment of claim **20**, wherein the endoscope or attachment comprises three or more offset devices.

26. The endoscope or attachment of claim **20** wherein the endoscope or attachment includes two or more offsets in a series, each offset being positioned 1 cm from each other.

27. A system or method comprising the use of an endoscope or attachment of claim **20** in a medical procedure.

28. A method of constructing a three-dimensional model of an airway or vessel of a patient comprising correlating a three-dimensional location of instrument at an internal position of the patient with image data collected in conjunction with a patient tracking device disposed on an external position of the patient.

29. The method of claim **28** wherein the construction comprises recording three-dimensional location of an instrument and corresponding EBUS video or images to construct a three-dimensional model of the patient's airway or a lesion therein.

30. The method of claim **28** wherein the construction comprises recording three-dimensional location and corresponding IVUS video or images to construct a three-dimensional model of the patient's vessel or a plaque therein.

31. The method of claim **28** wherein the construction comprises recording three-dimensional location and corresponding OCT images to construct a three-dimensional model of the patient's vessel or a plaque therein.

32. The method of claim **28** wherein the construction comprises the use of a fiber optic localization (FDL) device disposed on an instrument positioned within an airway or vessel of the patient and further comprises generating localization information and shape sensing information and applying an algorithm to said localization and shape sensing information to determine the location and orientation of the instrument within the patient.

33. A system or apparatus comprising one or more components for carrying out one or more elements of the method of claim **28**.

34. A non-transitory processor-readable medium storing code representing instructions to cause a processor to perform a process, the code comprising code to carry out one or more elements of the method of claim **28**.

* * * * *

专利名称(译)	用于四维软组织导航的装置和方法		
公开(公告)号	US20130303887A1	公开(公告)日	2013-11-14
申请号	US13/817730	申请日	2011-08-22
[标]申请(专利权)人(译)	HOLSING TROY大号 HUNTER MARK LEE CHRISTOPHER wennogle马克		
申请(专利权)人(译)	HOLSING , TROY L. HUNTER , MARK LEE , CHRISTOPHER WENNOGLE , MARC		
当前申请(专利权)人(译)	佛兰医疗技术有限公司		
[标]发明人	HOLSING TROY L HUNTER MARK LEE CHRISTOPHER WENNOGLE MARC		
发明人	HOLSING, TROY L. HUNTER, MARK LEE, CHRISTOPHER WENNOGLE, MARC		
IPC分类号	A61B1/267 A61B1/04 A61B8/08 A61M25/09 A61B8/12 A61B5/00 A61B5/06 A61B1/00		
CPC分类号	A61B1/2676 A61B5/061 A61B1/04 A61B1/0005 A61B1/00009 A61M25/09 A61B1/00094 A61B8/12 A61B5/0066 A61B8/0841 A61B5/065 A61B5/0456 A61B5/062 A61B5/064 A61B5/066 A61B5/113 A61B5/415 A61B5/418 A61B34/20 A61B90/39 A61B2034/2051 A61M2025/09183 A61B2034/2061 A61B2034/2063 A61B2034/2065 A61B2034/2068 G06T2207/30061		
优先权	61/375439 2010-08-20 US 61/375533 2010-08-20 US 61/375523 2010-08-20 US 61/375484 2010-08-20 US		
外部链接	Espacenet USPTO		

摘要(译)

提供了一种手术器械导航系统，其从驻留在患者腔体中的手术器械的视点可视地模拟患者体腔的虚拟体积场景。手术器械导航系统包括：手术器械；成像装置，其可操作以捕获代表给定患者内的感兴趣的内部区域的扫描数据；跟踪子系统，其采用电磁感测来捕获指示手术器械位置的实时位置数据；数据处理器，其可操作以从外科器械的角度呈现内部感兴趣区域的体积透视图像；以及显示器，其可操作以显示患者的体积透视图像。

