



US 20100159117A1

(19) **United States**

(12) **Patent Application Publication**
Griffin et al.

(10) **Pub. No.: US 2010/0159117 A1**

(43) **Pub. Date: Jun. 24, 2010**

(54) **SUPER ELASTIC GUIDEWIRE WITH SHAPE RETENTION TIP**

(22) Filed: **Mar. 1, 2010**

Related U.S. Application Data

(75) Inventors: **Stephen Griffin**, Sunnyvale, CA (US); **Ronald A. Sahatjian**, Lexington, MA (US)

(63) Continuation of application No. 10/025,668, filed on Dec. 18, 2001, now Pat. No. 7,670,302.

Publication Classification

Correspondence Address:
CROMPTON, SEAGER & TUFTE, LLC
1221 NICOLLET AVENUE, SUITE 800
MINNEAPOLIS, MN 55403-2420 (US)

(51) **Int. Cl.**
A61B 5/0215 (2006.01)

(52) **U.S. Cl.** **427/2.11**

(57) **ABSTRACT**

(73) Assignee: **BOSTON SCIENTIFIC SCIMED, INC.**, Maple Grove, MN (US)

A guidewire having a super elastic core surrounded by a shape memory polymer jacket. The super elastic core wire permits the guidewire to be navigated through tortuous vasculature without undergoing plastic deformation, and the shape memory polymer jacket permits the guidewire to be shaped by the physician.

(21) Appl. No.: **12/715,299**

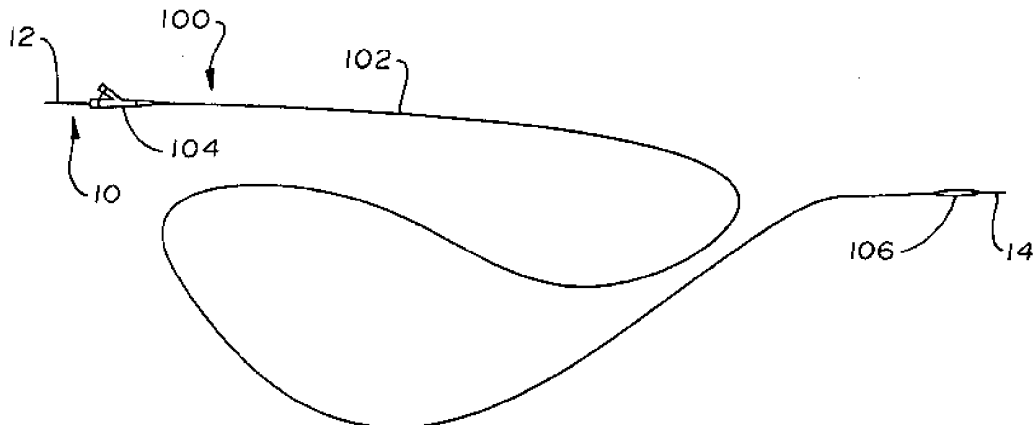

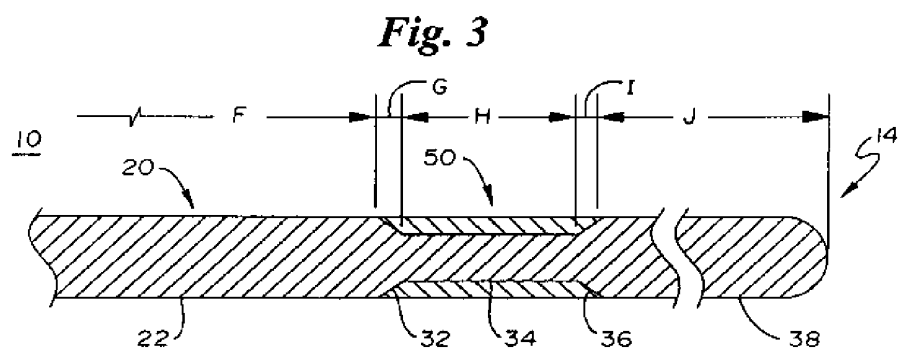
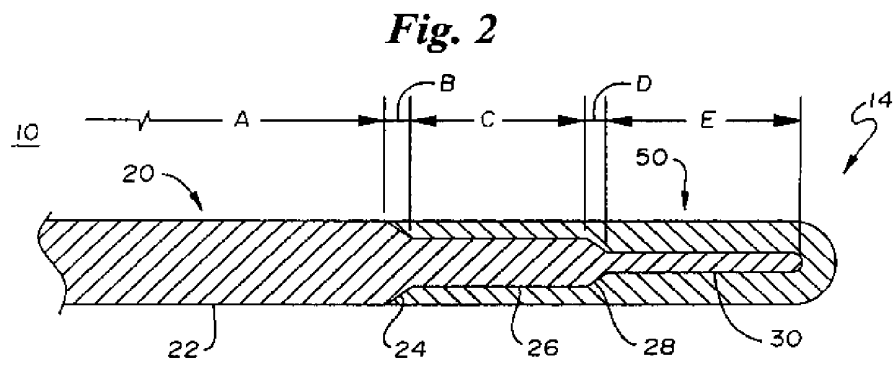
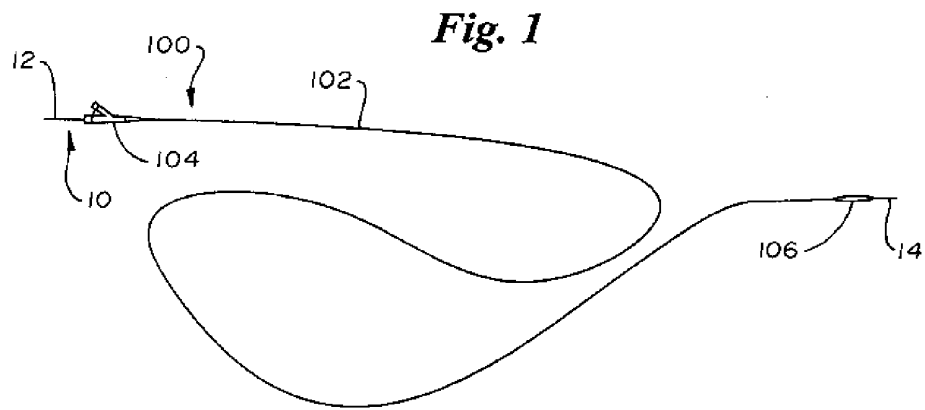

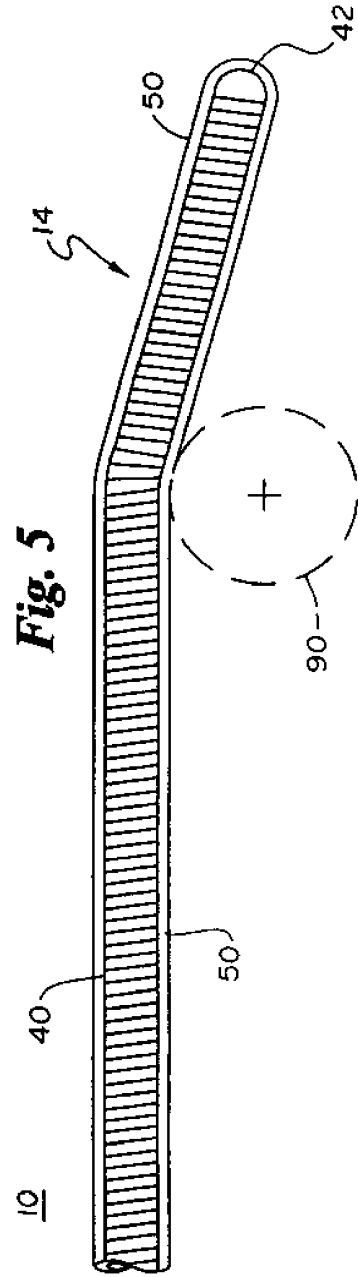
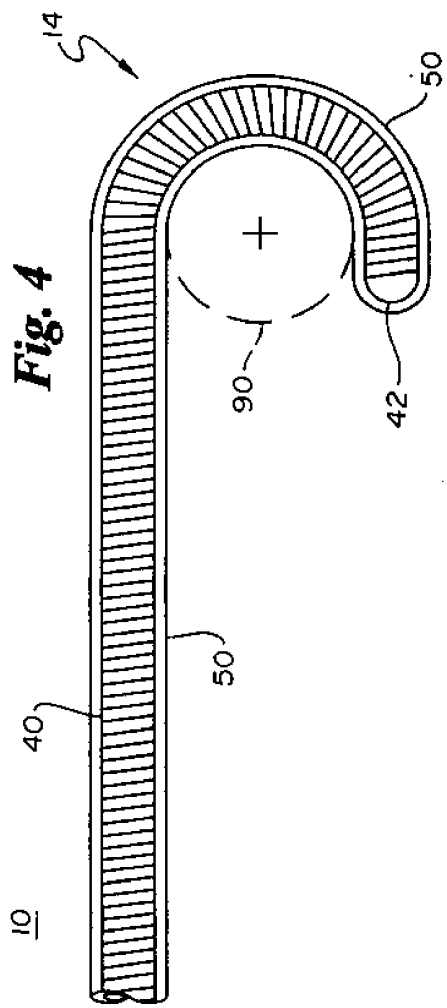

SUPER ELASTIC GUIDEWIRE WITH SHAPE RETENTION TIP

RELATED APPLICATIONS

[0001] This application is a continuation of U.S. application Ser. No. 10/025,668, filed Dec. 18, 2001, the entire disclosure of which is incorporated herein by reference.

FIELD OF THE INVENTION

[0002] The present invention generally relates to intravascular guidewires. More specifically, the present invention relates to intravascular guidewires utilizing super elastic materials.

BACKGROUND OF THE INVENTION

[0003] Intravascular guidewires are commonly used to navigate through a patient's vascular system for the diagnosis and treatment of a wide variety of vascular disorders. Guidewires conventionally utilize a stainless steel or nitinol (super elastic) core wire. Stainless steel core wires are advantageous because they are shapeable, but are disadvantageous because they may become deformed in tortuous vascular anatomy. Nitinol core wires are advantageous because they do not become deformed in tortuous vasculature, but are disadvantageous because they are not shapeable. Thus, there is a need for a guidewire that offers both advantages, namely a guidewire that is shapeable and that is not readily deformed in tortuous vasculature.

SUMMARY OF THE INVENTION

[0004] To address this need, the present invention provides several design alternatives. For example, in one embodiment, the present invention provides a guidewire having a super elastic core wire surrounded by a shape memory polymer jacket. The super elastic core wire permits the guidewire to be navigated through tortuous vasculature without undergoing plastic deformation, and the shape memory polymer jacket permits the guidewire to be shapeable.

BRIEF DESCRIPTION OF THE DRAWINGS

[0005] FIG. 1 is a plan view of a guidewire according to the present invention, in combination with a balloon catheter;

[0006] FIG. 2 is a foreshortened longitudinal cross-sectional view of a distal portion of a guidewire of the present invention, showing a polymer jacket surrounding a distal tip of a core wire;

[0007] FIG. 3 is a foreshortened longitudinal cross-sectional view of a portion of a guidewire of the present invention, showing a polymer jacket surrounding a mid portion of a core wire; and

[0008] FIGS. 4 and 5 are side views of a distal tip portion of a guide wire showing a polymer jacket surrounding a distal portion of a spring tip and core wire, wherein the distal tip is deformed about a cylinder-shaped object.

DETAILED DESCRIPTION OF THE INVENTION

[0009] The following detailed description should be read with reference to the drawings in which similar elements in different drawings are numbered the same. The detailed description and the drawings, which are not necessarily to scale, depict illustrative embodiments and are not intended to limit the scope of the invention.

[0010] Refer now to FIG. 1 which illustrates a plan view of a guidewire 10 in combination with an intravascular device 100. In this particular example, the intravascular device 100 comprises a balloon catheter, but those skilled in the art will recognize that guidewires may be used alone or in combination with a wide variety of intravascular devices for coronary, peripheral and cerebral use, including balloon catheters, guide catheters, diagnostic catheters, micro-catheters, etc. For purposes of illustration only, intravascular device 100 is shown to be a balloon catheter 100 having an elongate shaft 102, a proximally disposed manifold 104, and a distally disposed inflatable balloon 106, all of which are conventional in the art. Guidewire 10 may extend through the entire length of the balloon catheter 100, and includes a proximal end 12 and a distal tip portion 14. The guidewire 10 may have a size (length and diameter) to navigate coronary, peripheral and/or cerebral vasculature, depending on the particular clinical application, and the distal tip portion 14 may be shaped to facilitate steering in such vascular anatomy.

[0011] As seen in FIG. 2, the guidewire 10 may include a core wire 20 with a polymer jacket 50 surrounding a distal tip portion 14 thereof. Alternatively, the polymer jacket 50 may surround a mid portion of the guidewire 10 as shown in FIG. 3. As shown in FIGS. 4 and 5, a radiopaque coil 40 may surround a distal portion 14 of the core wire 20, with a distal weld 42 connecting the distal end of the coil 40 to the distal end of the core wire 20 (not visible in FIGS. 4 and 5). In this latter instance, the polymer jacket 50 may surround the core wire 20 and the radiopaque coil 40. As a further alternative, the polymer jacket 50 may surround an inner polymer jacket (not shown) disposed on the core wire 20, resulting in a multi-layered polymer jacket arrangement, with layer thicknesses that may vary, but preferably do not exceed the proximal profile of the guidewire. In all embodiments, the polymer jacket 50 may incorporate radiopaque filler.

[0012] In all embodiments illustrated, the polymer jacket 50 may surround the core wire 20 and/or radiopaque coil 40 to establish contact therebetween or to establish an annular space therebetween. In addition, the polymer jacket 50 may surround and encase the core wire 20 and/or radiopaque coil 40 to encase the distal tip 14 as shown in FIGS. 2, 4 and 5, or merely surround a portion thereof without encasing as shown in FIG. 3.

[0013] Core wire 20 may comprise a stainless steel metal or a super elastic metal such as nitinol (nickel titanium alloy) for purposes of navigating tortuous vasculature without causing plastic deformation thereof. Polymer jacket 50 may comprise a polymer and may have suitable dimensions and material characteristics that render the polymer jacket 50 more stiff than the distal tip portion 14 of the super elastic core wire 20 which it surrounds. As used herein, stiff or stiffness refers to the collective property defined by material characteristics and shape, as conventionally used in mechanical engineering design. In particular, the cross-sectional bending moment and the flexural modulus of the polymer jacket 50 may be selected such that when the tip 14 is deformed into a shape within the elastic limit of the super elastic core wire 20, and beyond the elastic limit of the polymer, the tip 14 substantially retains the shape, although some recoil may occur.

[0014] The polymer jacket 50 may comprise a shape memory polymer such as shape memory polyurethane available from Mitsubishi, polynorbomene polymers and copolymers (including blends with polyethylene and KRATON), polycaprolactone or (oligo)caprolactone copolymer, polym-

ethylmethacrylate, PLLA or PL/DLA copolymer, PLLA PGA copolymer, PMMA, cross-linked polyethylene, cross-linked polyisoprene, polycyclooctene, styrene-butadiene copolymer, or photocrosslinkable polymer including azo-dye, zwitterionic and other photoschromic materials (as referenced in *Shape memory Materials*, Otsuka and Wayman, Cambridge University press, ©1998).

[0015] With a shape memory polymer, the distal tip **14**, including polymer jacket **50**, core wire **20**, and/or radiopaque coil **40**, may be deformed into the desired shape. By way of example, not limitation, the distal tip portion **14** may be deformed about a cylindrical object **90** to impart a J-tip shape as shown in FIG. 4, or a bent-L shape as shown in FIG. 5. Although only basic shapes are shown, it is contemplated that a wide variety of simple and complex shapes may be achieved with the present invention. While the desired shape is maintained, the polymer jacket **50** may be subjected to heat at a temperature at or above the glass transition temperature (or near the melt temperature) of the shape memory polymer, and subsequently cooled to a temperature below the glass transition temperature. Once cooled, the distal tip **14** may be released from the constrained shape. The glass transition temperature is preferably greater than the temperature of the environment where guidewire **10** will be used (i.e., the internal body temperature of a patient), so as to sustain the desired shape while guidewire **10** is used (e.g., navigated through a vessel lumen of a patient). In other words, the temperature of the environment where guidewire **10** will be used is lower than the glass transition temperature that will allow polymer jacket **50** to change shape.

[0016] After releasing the distal tip **14** from the constrained shape, the elastic forces of the super elastic core wire **20** work against the polymer jacket **50**, biasing the shape of the distal tip back to the original (e.g., straight) configuration. However, the polymer jacket **50** has sufficient stiffness, by virtue of its size and its material properties, to substantially oppose, if not completely offset, the biasing force of the super elastic core wire **20**. The biasing force of the core wire **20** may be reduced by reducing the size (e.g., diameter) thereof, and the opposing force of the polymer jacket **50** may be increased by increasing the size (cross-sectional area moment) and/or the flexural modulus thereof. Thus, by substantially opposing, if not completely offsetting, the biasing force of the super elastic core wire **20**, the polymer jacket **50** substantially maintains the deformed shape, although some recoil may occur. To compensate for such recoil, the deformed shape may be exaggerated relative to the desired final shape.

[0017] The distal tip **14** may be re-shaped by re-deforming the distal tip **14** and exposing the polymer jacket **50** to heat at a temperature at or above the glass transition temperature (or near the melt temperature) of the shape memory polymer, and subsequently cooled to a temperature below the glass transition temperature. The original (e.g., straight) configuration of the distal tip **14** may be recaptured by exposing the polymer jacket **50** to heat at a temperature at or above the transformation temperature of the shape memory polymer, followed by cooling. The distal tip **14** may be repeatedly shaped without compromising shapeability or guidewire performance.

[0018] The polymer jacket **50** may surround the distal tip portion **14** as shown in FIG. 2 or a mid portion of the core wire **20** as shown in FIG. 3. To accommodate the polymer jacket **50** and to provide a uniform outer profile, the core wire **20** may be ground to have a single taper or a series of tapers as shown in FIG. 2 or ground to define a recess as shown in FIG. 3.

[0019] In FIG. 2, the distal portion **14** of the core wire **20** includes a series of tapers to accommodate the polymer jacket **50** and to provide a gradual reduction in stiffness toward the distal end thereof. For example, the core wire **20** may have a proximal uniform diameter portion **22** having a diameter of about 0.007 to 0.038 inches and a length "A" of about 100 to 260 cm, a mid uniform diameter portion **26** having a diameter of about 0.003 to 0.010 inches and a length "C" of about 5 to 30 cm, and a distal uniform diameter portion **30** having a diameter of about 0.0015 to 0.005 inches and a length "E" of about 5 to 30 cm. Alternatively, distal portion **30** may comprise a flat ribbon having a thickness of 0.0015 to 0.005 inches. The core wire **20** may also include tapered portions **24/28** between the uniform diameter portions **22/26/30**, having tapering diameters and lengths "B" and "D" of about 0.1 to 10 cm to provide a smooth transition between the uniform diameter portions **22/26/30**. As an alternative, the core wire **20** may have a continuous taper terminating in a radiopaque tip, and covered by the polymer jacket **50**.

[0020] In FIG. 3, a mid portion (i.e., a portion that is proximal of the distal end and distal of the proximal end) of the core wire **20** is provided with an optional recess having a uniform diameter portion **34** and two tapered portions **32/36**. The position of the recess **34** and thus the position of the polymer jacket **50** in this embodiment is dictated by the length "F" of the proximal uniform diameter portion **22** and the length "J" of the distal uniform diameter portion **38**. The length "H" of the recess portion **34** may be selected depending on the desired shapeable length of the core wire **20**. The lengths "G" and "I" of the tapered portion **32/36** may be the same or similar to that of tapered portions **24/28** described previously.

[0021] Those skilled in the art will recognize that the present invention may be manifested in a variety of forms other than the specific embodiments described and contemplated herein. Accordingly, departures in form and detail may be made without departing from the scope and spirit of the present invention as described in the appended claims.

What is claimed is:

1. A method of manufacturing an intravascular guidewire selectively shapeable by a user, the method comprising:
 - providing an elongate core wire having a distal tip portion; surrounding the distal tip portion with a polymer jacket, the polymer comprising a shape memory polymer;
 - deforming the distal tip portion and the polymer jacket into a desired position;
 - heating the polymer jacket to a temperature at or above a glass transition temperature of the polymer;
 - cooling the polymer jacket;
 - releasing the distal tip portion and the polymer jacket.
2. The method of claim 1, wherein the elongate core wire comprises a super elastic metal.
3. The method of claim 2, wherein the elongate core wire comprises nitinol.
4. The method of claim 1, wherein the elongate core wire comprises stainless steel.
5. The method of claim 1, further comprising disposing a radiopaque coil about the distal tip portion.
6. The method of claim 5, further comprising disposing an inner polymer layer over the radiopaque coil.
7. The method of claim 1, wherein the polymer comprises a material and a thickness sufficient to render the polymer stiffer than the distal tip portion.

8. The method of claim 7, wherein the polymer jacket substantially retains the deformed shape after the distal tip portion has been released.

9. The method of claim 1, further comprising:

reheating the polymer jacket to a temperature at or above the glass transition temperature of the shape memory polymer such that the polymer jacket returns to its original shape; and

cooling the polymer jacket to a temperature below the glass transition temperature of the polymer.

10. The method of claim 1, further comprising:

deforming the distal tip portion and the polymer jacket into a different shape;

reheating the polymer jacket to a temperature at or above the glass transition temperature of the polymer; and
cooling the polymer jacket to a temperature below the glass transition temperature.

11. The method of claim 1, wherein a portion of the elongate core wire proximal to the distal tip portion includes a recess having a constant diameter portion and two tapered portions.

12. The method of claim 11, further comprising a shape memory polymer disposed within the recess.

13. A method of manufacturing an intravascular guidewire selectively shapeable by a user, the method comprising:

providing an elongate core wire including a constant diameter portion and a tapered distal tip portion extending distally from the constant diameter portion;

surrounding the distal tip portion with a polymer jacket such that the polymer jacket has an outer diameter similar to the constant diameter portion, the polymer comprising a shape memory polymer;

deforming the distal tip portion and the polymer jacket around an object to impart a J-tip shape;

heating the polymer jacket to a temperature at or above a glass transition temperature of the polymer;

cooling the polymer jacket below the glass transition temperature of the polymer;

releasing the distal tip portion and the polymer jacket to result in a final shape of the distal tip portion and the polymer jacket.

14. The method of claim 13, wherein the deformed J-tip shape is exaggerated relative to the final shape of the distal tip portion and polymer jacket.

15. The method of claim 13, wherein the polymer jacket substantially retains the J-tip shape after the distal tip portion and polymer jacket have been released.

16. The method of claim 13, wherein the distal tip portion comprises a series of tapered portions.

17. The method of claim 13, wherein the polymer jacket includes a radiopaque filler.

18. The method of claim 13, further comprising:

reheating the polymer jacket to a temperature at or above the glass transition temperature of the shape memory polymer such that the polymer jacket returns to its original shape; and

cooling the polymer jacket to a temperature below the glass transition temperature of the polymer.

19. The method of claim 13, further comprising:

deforming the distal tip portion and the polymer jacket into a different shape;

reheating the polymer jacket to a temperature at or above the glass transition temperature of the polymer; and

cooling the polymer jacket to a temperature below the glass transition temperature.

20. A method of manufacturing an intravascular guidewire selectively shapeable by a user, the method comprising:

providing an elongate core wire, formed at least in part of nitinol, the elongate core wire including a constant diameter portion and a tapered distal tip portion extending distally from the constant diameter portion;

surrounding the distal tip portion with a polymer jacket such that the polymer jacket has an outer diameter similar to the constant diameter portion, the polymer comprising a shape memory polymer from a subset of polymers which are characterized by their responsiveness to heating at or above a glass transition temperature of the shape memory polymer to transform the shape memory polymer between a first shape and a second shape;

deforming the distal tip portion and the polymer jacket to impart a desired shape;

heating the polymer jacket to a temperature at or above the glass transition temperature of the polymer;

cooling the polymer jacket to a temperature below the glass transition temperature of the polymer; and

releasing the distal tip portion and the polymer jacket;

wherein after the distal tip portion and polymer jacket have been released, the shape memory polymer overcomes a biasing force of the nitinol wire to substantially maintain the desired shape.

* * * * *

专利名称(译)	具有形状保持尖端的超弹性导丝		
公开(公告)号	US20100159117A1	公开(公告)日	2010-06-24
申请号	US12/715299	申请日	2010-03-01
[标]申请(专利权)人(译)	波士顿科学西美德公司		
申请(专利权)人(译)	BOSTON SCIENTIFIC SCIMED , INC.		
当前申请(专利权)人(译)	BOSTON SCIENTIFIC SCIMED , INC.		
[标]发明人	GRIFFIN STEPHEN SAHATJIAN RONALD A		
发明人	GRIFFIN, STEPHEN SAHATJIAN, RONALD A.		
IPC分类号	A61B5/0215 A61L27/00 A61B5/00 A61M25/01 A61M25/09		
CPC分类号	A61L31/022 A61L31/10 A61M2025/09141 A61M25/09 A61L2400/16		
外部链接	Espacenet USPTO		

摘要(译)

一种导丝，具有由形状记忆聚合物护套包围的超弹性芯。超弹性芯线允许导丝穿过曲折的脉管系统而不经历塑性变形，并且形状记忆聚合物护套允许导丝由医师成形。

