



US 20060258916A1

(19) **United States**

(12) **Patent Application Publication**
Pietersen

(10) **Pub. No.: US 2006/0258916 A1**

(43) **Pub. Date: Nov. 16, 2006**

(54) **DEVICE FOR MONITORING THE
CONDITION OF A HUMAN BEING**

Aug. 8, 2003 (ZA)..... 2003/6138
Oct. 24, 2003 (ZA)..... 2003/8285

Publication Classification

(76) **Inventor: Johannes de Klerk Pietersen,**
Centurion (ZA)

Correspondence Address:
DAVID A. GUERRA
INTERNATION PATENT GROUP, LLC
10TH FLOOR, 610 8TH AVENUE S.W.
CALGARY, AB T2P 1G5 (CA)

(51) **Int. Cl.**
A61B 5/02 (2006.01)
A61B 5/00 (2006.01)
A61B 5/08 (2006.01)
(52) **U.S. Cl.** **600/301; 600/549; 600/534;**
600/483; 600/500

(21) **Appl. No.: 11/307,361**

(22) **Filed: Feb. 2, 2006**

(30) **Foreign Application Priority Data**

Aug. 4, 2004 (WO)..... PCT/ZA04/00091
Aug. 4, 2003 (ZA)..... 2003/0949

(57) **ABSTRACT**
A device for continuously monitoring one or more indicators relating to the health or comfort of a person **12** includes one or more sensing means for measuring a value of one or more desired indicators and a communicating means **13** communicating an alarm signal when the measured value is above or below a predetermined value or range of values range, wherein the device **10** is adapted to be attached to an item of clothing **14** of the person **12**.

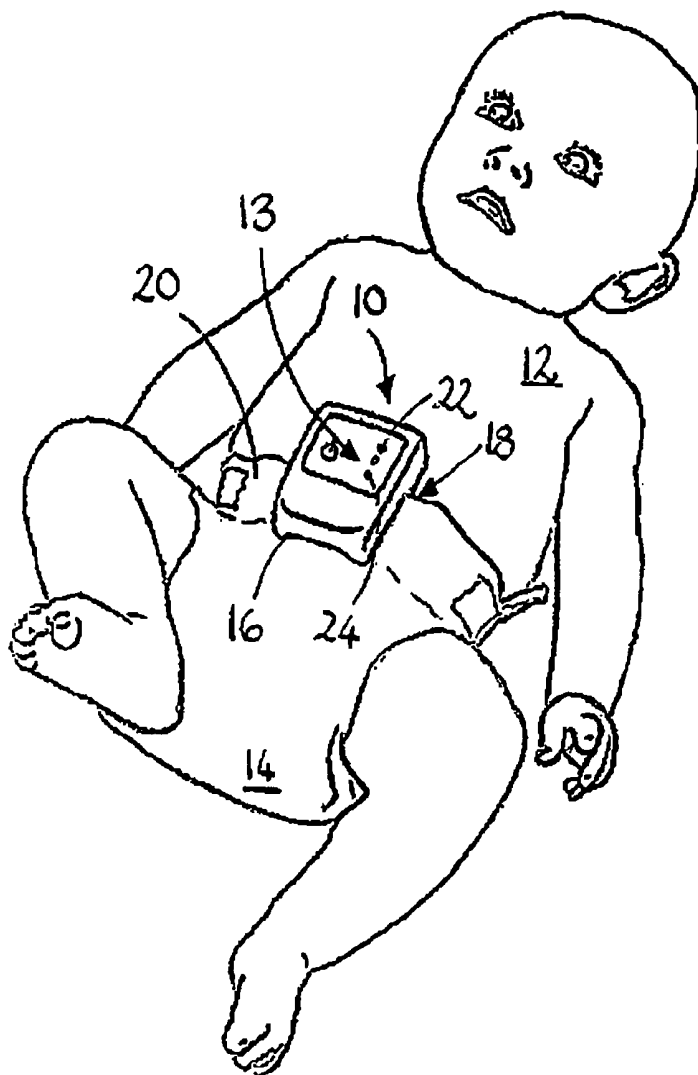

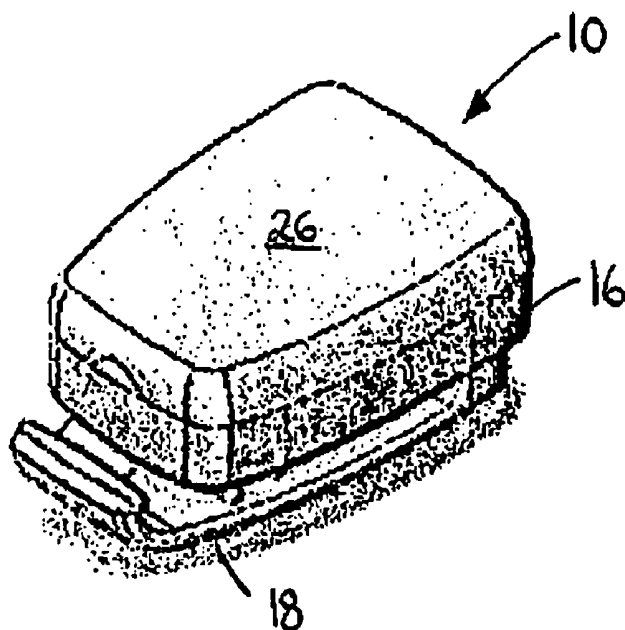

Figure 1

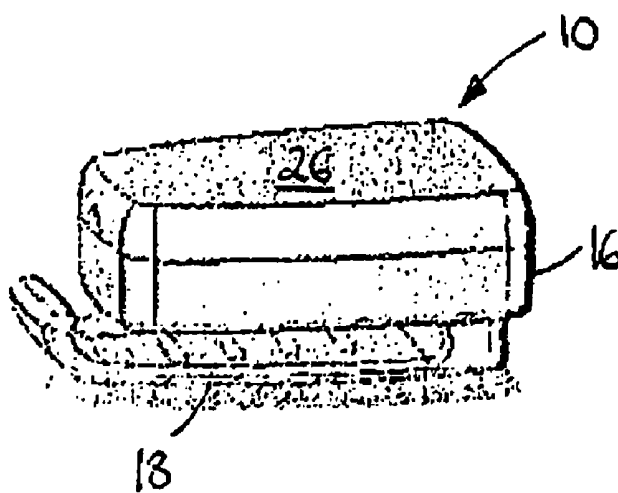

Figure 2

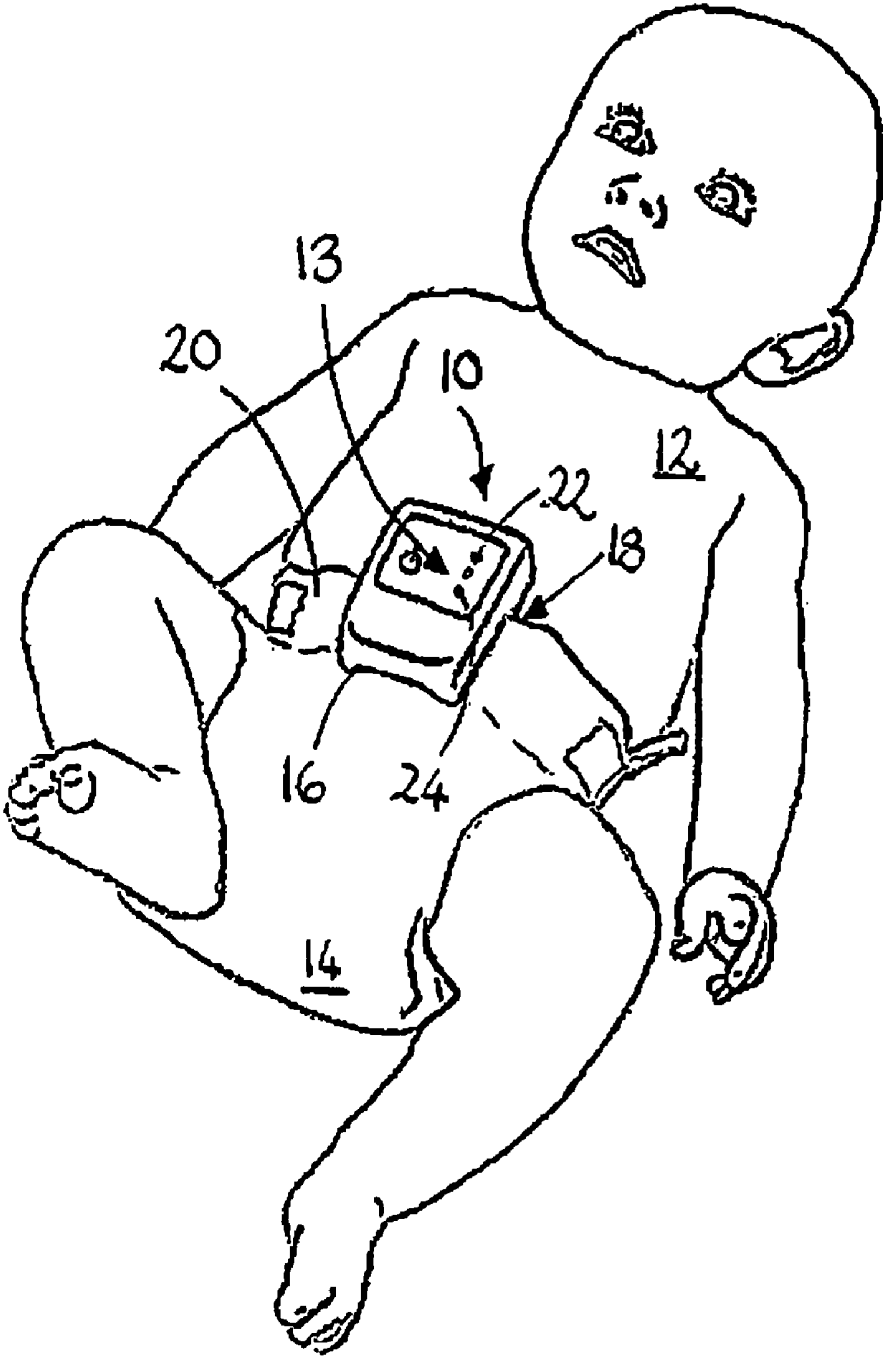

Figure 3

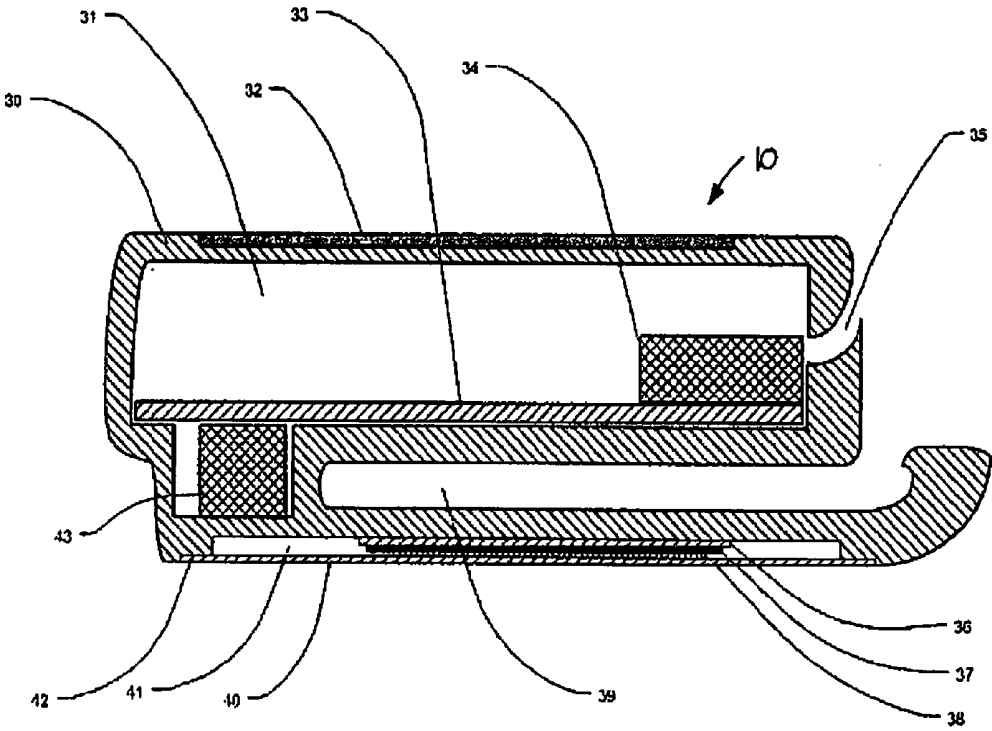

Figure 4

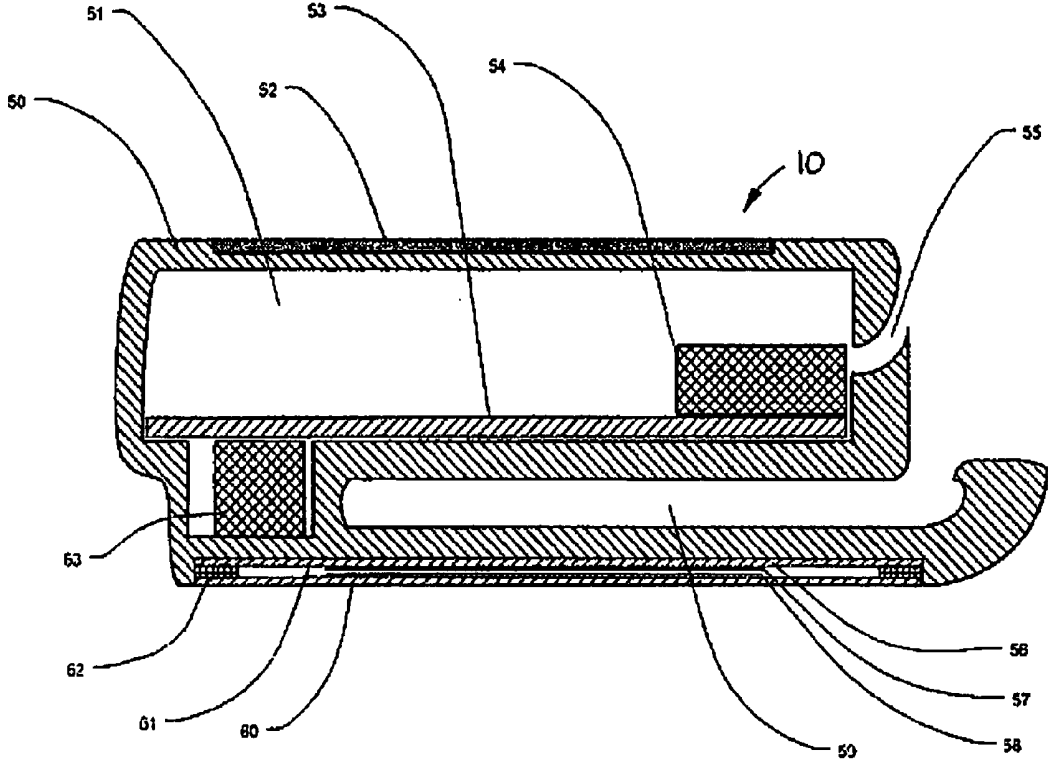

Figure 5

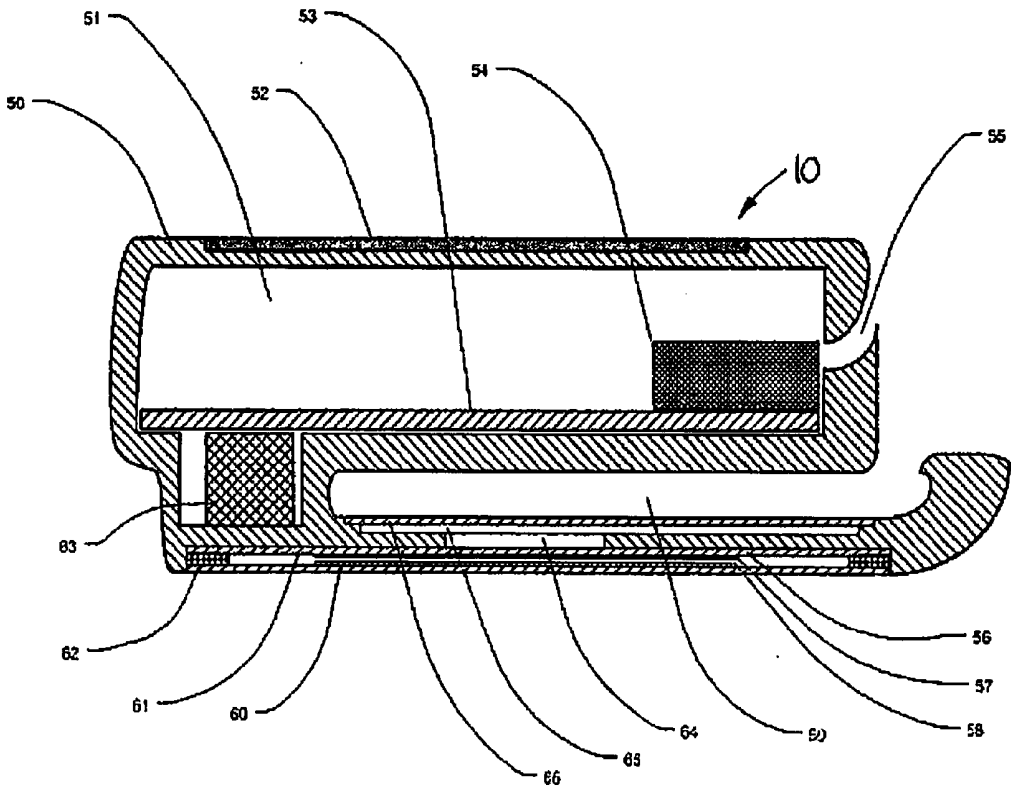

Figure 6

**DEVICE FOR MONITORING THE CONDITION OF
A HUMAN BEING****CROSS-REFERENCE TO RELATED
APPLICATIONS**

[0001] This application is an U.S. national phase application under 35 U.S.C. §371 based upon co-pending International Application No. PCT/ZA2004/00009 filed Aug. 4, 2004. Additionally, this U.S. national phase application claims the benefit of priority of co-pending International Application No. PCT/ZA2004/00009 filed Aug. 4, 2004, South African Application No. ZA 2003/0949 filed Aug. 4, 2003, South African Application No. ZA 2003/6138 filed Aug. 8, 2003, and South African Application No. ZA 2003/8285 filed Oct. 24, 2003. The entire disclosures of the prior applications are incorporated herein by reference. The international application was published in the English language on Feb. 10, 2005 under Publication No. WO 2005/011491.

FIELD OF THE INVENTION

[0002] This invention relates to a device for monitoring one or more indicators relating to the health or comfort of a human being and for communicating the sensed information to a caretaker of the human being.

BACKGROUND TO THE INVENTION

[0003] Monitors for sensing the heart rate, breathing or other vital functions of a hospitalized person are well known in the art. Devices for home use have been developed to aid in the care of infants or elderly persons to monitor breathing, heart rate, and the like. These devices are however often too complicated to be operated by an unskilled person and/or cause discomfort to the person being monitored.

[0004] In U.S. Pat. No. 5,400,012, a breathing monitor is disclosed for detecting Sudden Infant Death Syndrome (SIDS) in infants caused by apnea, which monitor includes an enclosure that is attached to the torso of an infant using a strap. The enclosure is supported by and isolated from the infant's torso by a fluid filled bladder coupler such that there is no direct contact between the enclosure and the torso of the infant. A monitor including a piezoelectric element is connected to the fluid coupler and a battery powered electronic circuit contained in the enclosure flashes an LED as the infant breathes and sounds an alarm should the infant fail to exhale for a predetermined period of time. An adjustable strap connector for the strap provides visual indication of the strap being correctly attached and a limited range of motion is permissible between the strap and the enclosure when the infant breathes.

[0005] In U.S. Pat. No. 4,146,885 a hospital bed or mattress for infants including a respiration monitor and alarm to detect apnea is disclosed. The infant's breathing causes slight displacements of portions of its body which in turn transmit dynamic recoil forces to the bed on which the infant is resting.

[0006] The monitors disclosed in the prior art suffer from a number of drawbacks. A most basic disadvantage of known monitors is that securing the device to the body of an infant is a cumbersome task which does not encourage use of the device. Known devices are in addition uncomfortable to wear, easily become displaced in use and require a skilled user.

[0007] The inventor therefore believes that a need exists for a device for monitoring various indicators relating to the health or comfort of an infant or grown person and for communicating information to a caretaker of the infant or grown person and which device overcomes at least some of the disadvantages of the prior art.

SUMMARY OF THE INVENTION

[0008] According to the invention, there is provided a device for continuously monitoring one or more indicators relating to the health or comfort of a person, the device including:

[0009] one or more sensing means for sensing and measuring a value of one or more desired indicators; and

[0010] a communicating means for communicating an alarm signal when the measured value is above or below a predetermined value or range of values, wherein the device is adapted to be attached to an item of clothing of the person.

[0011] The desired indicator may be selected from the group including: breathing, heartbeat, temperature, and humidity.

[0012] The sensing means may be located in a housing of the device.

[0013] The device may include a clip extending from the housing so that it is attachable to the waistband of an item of clothing worn by the person being monitored. In the case of an infant, the device may be attached to a waistband of a diaper worn by the infant. In the case of an adult, the device may be attached to a waistband of an undergarment worn by the adult.

[0014] The sensing means for sensing and measuring breathing of the person may be in the form of a pressure transducer which in use is located between the item of clothing and the skin of the person wearing the device. The pressure transducer may measure pressure exerted on it by the lifting and falling of the skin of the breathing person. When the pressure exerted on the pressure transducer occurs in irregular intervals or ceases for a predetermined period of time, this may activate the communicating means.

[0015] When the pressure transducer measures pressure that occurs in irregular intervals or ceases for a predetermined period of time, it may activate a stimulating means aimed at encouraging the person to breathe normally either prior to or simultaneously with activating the communicating means. The stimulating means may be in the form of a conventional vibrating mechanism that causes the housing of the device to vibrate.

[0016] The sensing means for sensing and measuring the breathing of a person may be sufficiently sensitive to additionally sense the heartbeat of a person. When an irregular heartbeat or a cessation in heartbeat is sensed, this may activate the communicating means.

[0017] The device may include a further sensing means for sensing temperature and which in use is located between the item of clothing and the skin of the person wearing the device. The temperature sensor may continuously sense and measure temperature and may activate the communicating means should the measured temperature be below or above a predetermined value or value range.

[0018] Additionally, a sensing means for sensing temperature and which is in use located exterior the item of clothing of the person wearing the device, may be provided. The values measured by the two temperature sensors may be compared continuously so as to calculate the rate of heat loss of the person wearing the device. When the rate of heat loss falls below or rises above a predetermined value or range of values, this may activate the communicating means.

[0019] The device may include yet a further sensing means for sensing and measuring humidity and that is in use located between the item of clothing and the skin of the person wearing the device. When the value of the humidity rises above a certain predetermined value, this may activate the communicating means.

[0020] Additionally, a sensing means for sensing humidity and which is in use located exterior the item of clothing of the person wearing the device, may be provided. The values measured by the two humidity sensors may be compared continuously so as to be able to ascertain when the humidity level between the item of clothing and skin of the person rises above a desired value at which stage the communicating means may be activated.

[0021] The humidity sensor may be in the form of a conductivity sensor. As an increase in humidity leads to an increase in conductivity, when the conductivity rises above a predetermined value, the communicating means may be activated.

[0022] The sensing and measuring of humidity is particularly useful when the device is used to monitor an infant, in that an increase in humidity indicates a soiled diaper which can then be changed timeously by a caretaker of the infant before any discomfort is caused.

[0023] The communicating means may include one or more of the following: an audible alarm, a visual signal such as a flashing light, and a radio signal transmitted to a suitable remotely located receiver.

[0024] The housing and clip may be manufactured from any suitable synthetic plastics material.

[0025] The device may include a power source in the form of, for example, batteries located in the housing.

[0026] The device may include an interface on the housing to permit setting of the various values or value ranges at which the communicating means is to be activated and for switching the device on and off. The housing may be provided with a cover for covering the interface so as to inhibit the device from accidentally being turned off or reprogrammed during use.

[0027] The device may be provided with a data storage device for storing the information sensed by the sensing means. A user may retrieve the stored data at any time for the purpose of analysis.

[0028] The invention extends to an item of clothing which includes a device as described above.

BRIEF DESCRIPTION OF THE DRAWINGS

[0029] In the drawings:

[0030] **FIG. 1** shows a first isometric view of a device in accordance with the present invention;

[0031] **FIG. 2** shows a second isometric view of the device of **FIG. 1**;

[0032] **FIG. 3** shows an isometric view of the device of **FIG. 1** in use when attached to the diaper of an infant;

[0033] **FIG. 4** shows a cross sectional side view an alternative embodiment of a device in accordance with the present invention;

[0034] **FIG. 5** shows a cross sectional side view an alternative embodiment of a device in accordance with the present invention; and

[0035] **FIG. 6** shows a cross sectional side view an alternative embodiment of a device in accordance with the present invention.

DETAILED DESCRIPTION OF THE INVENTION

[0036] The invention will now be described by way of the following non-limiting examples with reference to the accompanying drawings.

[0037] In the drawings:—**FIG. 1** shows a first isometric view of a device in accordance with the present invention; **FIG. 2** shows a second isometric view of the device of **FIG. 1**; **FIG. 3** shows an isometric view of the device of **FIG. 1** in use when attached to the diaper of an infant; and **FIGS. 4, 5, and 6** show cross sectioned side views showing details of three alternative constructions of a device in accordance with the present invention.

[0038] In the drawings, reference numeral **10** generally indicates a device for continuously monitoring one or more indicators relating to the health or comfort of a person **12** in accordance with the present invention. In the embodiment shown the person **12** is an infant.

[0039] The device **10** includes one or more sensing means for sensing and measuring a value of one or more desired indicators and a communicating means **13** communicating an alarm signal when the measured value is above or below a predetermined value or range of values, wherein the device **10** is adapted to be attached to an item of clothing **14** of the person **12**.

[0040] The desired indicator includes breathing, temperature, and humidity.

[0041] The sensing means is located in a housing **16** of the device **10**. The device **10** includes a clip **18** extending from the housing **16** so that it is attachable to the waistband **20** of an item of clothing **14** (in this case a diaper) worn by the person **12** being monitored.

[0042] The sensing means for sensing and measuring breathing of the person **12** is in the form of a pressure transducer which in use is located between the item of clothing **14** and the skin of the person **12** wearing the device **10**. The pressure transducer measures pressure exerted on it by the lifting and falling of the skin of the breathing person **12**. When the pressure exerted on the pressure transducer occurs in irregular intervals or ceases for a predetermined period of time, this activates the communicating means **13**.

[0043] When the pressure transducer measures pressure that occurs in irregular intervals or ceases for a predetermined period of time, it activates a stimulating means aimed

at encouraging the person 12 to breathe normally either prior to or simultaneously with activating the communicating means 13. The stimulating means is in the form of a conventional vibrating mechanism that causes the housing 16 of the device 10 to vibrate.

[0044] The device 10 includes a further sensing means for sensing temperature and which in use is located between the item of clothing 14 and the skin of the person 12 wearing the device 10.

[0045] The temperature sensor continuously senses and measure temperature and activates the communicating means 13 should the measured temperature be below or above a predetermined value or value range.

[0046] The device 10 includes yet a further sensing means for sensing and measuring humidity that is in use located between the item of clothing 14 and the skin of the person 12 wearing the device 10. When the value of the humidity rises above a certain predetermined value, this activates the communicating means 13.

[0047] The humidity sensor is in the form of a humidity sensor that measures the percentage humidity present in the air. The humidity sensor is an electronic component. When the humidity rises above a predetermined value, the communicating means 13 is activated.

[0048] The sensing and measuring of humidity is particularly useful when the device 10 is used according to the embodiment shown, in that an increase in humidity indicates a soiled diaper which can be changed timeously by a caretaker of the infant before any discomfort is caused as soon as the communication means 13 is activated.

[0049] The communicating means 13 includes an audible alarm 22 as well as a flashing light 24.

[0050] The housing 16 and clip 18 are manufactured from any suitable synthetic plastics material.

[0051] The device 10 includes a power source in the form of batteries located in the housing 16.

[0052] The device 10 includes an interface (not shown) on the housing 16 to permit setting of the various values or value ranges at which the communicating means 13 is to be activated and for switching the device 10 on and off. The housing 16 is provided with a cover 26 for covering the interface so as to inhibit the device 10 from accidentally being turned off or reprogrammed during use.

[0053] Referring now to FIG. 4:

[0054] The device 10 includes a housing 30 defining a chamber 31 for housing the electronic circuitry of the device 10. The housing 30 is manufactured from any suitable non-toxic, hypoallergenic, synthetic plastics material.

[0055] The device 10 includes a user interface panel 32 using known technology in electrical communication with the electronic circuitry. Detail of the user interface panel 32 (not shown) includes one or more push-button switches (of the type typically used in membrane keypads) for enabling and disabling the device, or for changing the settings of the device. The interface panel 32 further accommodates one or more light-emitting diodes, liquid crystal displays or other components for visual indications.

[0056] An electronic printed circuit board 33 is located in the housing 30. Various components, including a power source (typically a long-life or rechargeable battery) are affixed to the board 33. For safety reasons the housing 30 of the device 10 is permanently sealed to inhibit access to the components housed therein. However, it could also be manufactured in such a way that the user can gain access to the power source in order to replace it.

[0057] A sound transducer 34 for generating an audible alarm, such as a piezo-electric element is also included in the housing 30. An opening 35 in the housing 30 permits sound generated by the sound transducer 34 to escape from the chamber 31. Other methods of generating audible alarms and transmitting them through the housing 30 are possible and need not involve an opening.

[0058] A suitable material 36 is used to affix piezo-electric element 37 to the device 10. The element 37 can also be used as a spacer to adapt the thickness of piezo-electric element 37 to the recess depth. Alternatively, the piezo-electric element 37 can also be glued directly to the device 10.

[0059] The piezo-electric element 37 is in electrical communication with the electronic circuitry of the device 10. Applying fluctuating pressure to such an element 37 generates a corresponding fluctuating electronic potential that can be measured by the circuitry.

[0060] A suitable spacer 38 between piezo-electric element 37 and an outer membrane can be incorporated.

[0061] Slot 39 is configured and dimensioned to accommodate the top edge of a diaper, allowing the sensor to rest against the body of an infant in order to measure changes in pressure associated with, for example, breathing. Once fitted, a typical disposable diaper's "waistband" section creates a supple but snug structure around the infant's torso. As the infant breathes its abdomen will press more and less forcefully against this waistband section of the diaper, in unison with its breathing effort. Because the device 10 is secured to this waistband section, fluctuations of the pressure exerted by the infant's abdomen will cause fluctuations of pressure against the portion of the device 10 that is located on the inside of the diaper.

[0062] An outer flexible membrane 40 is manufactured from a suitable material such as polyester or polycarbon. Pressure applied to this membrane 40 is transmitted through 38 (if present) to 37, allowing measurement of such pressure by the device 10.

[0063] Cavity 41 accommodates a sensor assembly. Cavity 41 is smaller in area than outer membrane 40, to permit an overlap 42. Outer membrane 40 is affixed to this flange by suitable means such as waterproof glue, to preventing ingress of moisture into the device 10.

[0064] Motor 43 includes and offset weight attached to spindle, commonly used for "silent ring" of cellular telephones. The offset weight causes a vibration when the motor 43 is energized, said vibration being transferred to the housing 30 of the device. This vibration is used to provide tactile stimulation to the skin of the infant under situations deemed necessary. Other means of causing tactile stimulation may be used.

[0065] Referring now to FIG. 5:

[0066] In FIG. 5, reference numerals 50 to 55, 59 and 63 represent the same elements as reference numerals 30 to 35, 39 and 43 in FIG. 4 and will therefore not be described further.

[0067] A suitable substrate 56 for a sensor is provided and is typically a membrane as used in flexible electronic circuitry, i.e. polyester or polycarbonate, suitably affixed to the device 10.

[0068] A deposit of suitable electrically resistive material 57 such as graphite paint, typically used in electronic component manufacturing, is in electrical communication with the circuitry of the device 10. A deposit 58 of suitable electrically conductive material such as conductive silver paint, typically used in electronic component manufacturing, is located on element 60. The deposit 58 is of a suitable size and shape corresponding to and aligned with that of deposit 57 over an area preferably stretching from the center of cavity 61 towards the edges of said cavity 61.

[0069] A flexible membrane 60, typically polyester, polycarbonate or similar as used in flexible electronic circuit manufacturing, and preferably hypoallergenic to prevent contact dermatitis covers deposits 57 and 58.

[0070] Pressure exerted on the membrane 60 will cause it to flex towards membrane 56. If sufficient pressure is applied, the two membranes 56 and 60 will make contact. With even more pressure, the contact area between the two membranes 56 and 60 will become larger. The electrical resistance of 57 can be measured. Forcing the two membranes 56 and 60 together will allow deposit 58 to make contact with 57. Because deposit 58 has a lower resistance than deposit 57, changing the contact area between deposits 57 and 58 will cause the measured resistance of deposit 57 to change accordingly, decreasing as more of deposit 58 makes contact with it and increasing as less of deposit 58 comes into contact with it. In practice a slight bulge (not shown) introduced below deposit 57 will cause it to remain in contact with deposit 58, allowing very slight pressures on deposit 58 to be measured.

[0071] Spacer 62 between flexible membranes 56 and 60 creates a cavity of suitable dimensions. Spacer 62 can be coated with adhesive on both sides to allow easy assembly of the sensor as a unit, and can be made of the same materials used for membranes 57 and 60.

[0072] Referring now to FIG. 6:

[0073] A more complicated device 10 can be made by manufacturing a cavity 65 opposite the sensor, on the inside of the "clip" section. A third membrane 66 can then be affixed to that side so that it completely covers the cavity 65. A port 64 can also be made through the clip so that it connects the cavity between this membrane with the area behind membrane 57. If the port and cavity so described are then filled with fluid (and provided that portion of membrane 56 that is located underneath the graphite deposit is not permanently affixed to the housing 30 of the device 10), pressure exerted by the waistband of the diaper on membrane 66 will be transferred through the membrane by the fluid to the underside of membrane 57, pressing 57 towards 60 and allowing pressure from both sides of the clip to be

measured. Such a sensor is expected to be more sensitive than those disclosed in the embodiments of FIGS. 4 and 5.

[0074] It is to be appreciated, that the invention is not limited to any specific embodiment or configuration as hereinbefore generally described or illustrated.

What is claimed is:

1. A health monitoring device for continuously monitoring one or more indicators relating to the health or comfort of a person, said health monitoring device comprising:

at least one sensing means for sensing and measuring a value of one or more desired indicators; and

a communicating means for communicating an alarm signal when said measured value is above or below a predetermined value or range of values, wherein said health monitoring device is adapted to be attached to an item of clothing of the person.

2. The health monitoring device as set forth in claim 1, wherein said desired indicator is selected from the group consisting of breathing, heartbeat, temperature, and humidity.

3. The health monitoring device as set forth in claim 2 further comprising a housing and a clip extending from said housing so that it is attachable to a waistband of an item of clothing worn by the person being monitored.

4. The health monitoring device as set forth in claim 3, wherein said item of clothing is selected from the group consisting of a conventional diaper, and a conventional garment.

5. The health monitoring device as set forth in claim 4, wherein said breathing sensing and measuring means is a pressure transducer positionable between the item of clothing and the skin of the person wearing said health monitoring device, said pressure transducer is adapted to measure the pressure exerted on it by the lifting and falling of the skin of the breathing person and activates said communicating means when the pressure exerted on said pressure transducer occurs in irregular intervals or ceases for a predetermined period of time.

6. The health monitoring device as set forth in claim 5 further comprising a stimulating means activated by said pressure transducer, said stimulating means being adapted to encourage the person to breathe normally prior to or simultaneously with the activating of said communicating means, wherein said stimulating means is a vibrating mechanism.

7. The health monitoring device as set forth in claim 6, wherein said breathing sensing means is sufficiently sensitive to additionally sense the heartbeat of the person and wherein an irregular heartbeat or a cessation in heartbeat is sensed, said communicating means is activated.

8. The health monitoring device as set forth in claim 3 further comprising a temperature sensing and measuring means and which in use is positionable between the item of clothing and the skin of the person wearing said health monitoring device, and wherein said temperature sensing means continuously senses and measures temperature and activates said communicating means should the measured temperature be below or above a predetermined value or value range.

9. The health monitoring device as set forth in claim 8 further comprising an additional temperature sensing and measuring means which is positionable exterior the item of clothing of the person wearing said health monitoring

device, wherein said values measured by said two temperature sensors is compared continuously so as to calculate the rate of heat loss of the person wearing said health monitoring device, wherein when said rate of heat loss falls below or rises above a predetermined value or value range, said communicating means is activated.

10. The health monitoring device as set forth in claim 3, wherein said clip further comprising a humidity sensing and measuring means positionable between the item of clothing and the skin of the person wearing said health monitoring device, wherein when said measured humidity value rises above a certain predetermined value, said communicating means is activated.

11. The health monitoring device as set forth in claim 10 further comprising an additional humidity sensing and measuring means positionable exterior the item of clothing of the person wearing said health monitoring device, wherein the values measured by said both humidity sensors are compared continuously so as to be able to ascertain when the humidity level between the item of clothing and the skin of the person rises above a desired value at which stage said communicating means is activated.

12. The health monitoring device as set forth in claim 11, wherein said humidity sensors are conductivity sensors.

13. The health monitoring device as set forth in claim 1, wherein said communicating means is selected from the group consisting of an audible alarm, a visual signal, a flashing light, and a radio signal transmitted to a remotely located receiver.

14. A health monitoring device comprising:

a housing;

at least one sensing means for sensing and measuring a value of one or more desired indicators selected from the group consisting of breathing, heartbeat, temperature, and humidity;

a communicating means for communicating an alarm signal when said measured value is above or below a predetermined value or range of values, wherein said health monitoring device is adapted to be attached to an item of clothing of a person;

a clip extending from said housing adapted to be attachable to a waistband of the item of clothing worn by the person being monitored;

a pressure transducer positionable between the item of clothing and the skin of the person wearing said health monitoring device, said pressure transducer is adapted to measure the pressure exerted on it by the lifting and falling of the skin of the breathing person and activates said communicating means when the pressure exerted on said pressure transducer occurs in irregular intervals or ceases for a predetermined period of time;

a temperature sensing and measuring means positionable between the item of clothing and the skin of the person wearing said health monitoring device, and wherein said temperature sensing means continuously senses and measures temperature and activates said communicating means should the measured temperature be below or above a predetermined value;

a humidity sensing and measuring means positionable between the item of clothing and the skin of the person wearing said health monitoring device, wherein when

said measured humidity value rises above a certain predetermined value, said communicating means is activated; and

a stimulating means activated by said pressure transducer, said stimulating means being adapted to encourage the person to breathe normally prior to or simultaneously with the activating of said communicating means.

15. The health monitoring device as set forth in claim 14 further comprising an additional temperature sensing and measuring means which is positionable exterior the item of clothing of the person wearing said health monitoring device, wherein said values measured by said two temperature sensors is compared continuously so as to calculate the rate of heat loss of the person wearing said health monitoring device, wherein when said rate of heat loss falls below or rises above a predetermined value or value range, said communicating means is activated.

16. The health monitoring device as set forth in claim 15 further comprising an additional humidity sensing and measuring means positionable exterior the item of clothing of the person wearing said health monitoring device, wherein the values measured by said both humidity sensors are compared continuously so as to be able to ascertain when the humidity level between the item of clothing and the skin of the person rises above a desired value at which stage said communicating means is activated.

17. The health monitoring device as set forth in claim 16, wherein said pressure transducer, said temperature sensor, said additional temperature sensor, said humidity sensor, and said additional humidity sensor being positionable in said clip.

18. A health monitoring device comprising:

a housing;

at least one sensing means for sensing and measuring a value of one or more desired indicators selected from the group consisting of breathing, heartbeat, temperature, and humidity;

a communicating means for communicating an alarm signal when said measured value is above or below a predetermined value or range of values, wherein said health monitoring device is adapted to be attached to an item of clothing of a person;

a clip extending from said housing adapted to be attachable to a waistband of the item of clothing worn by the person being monitored;

a pressure transducer positionable in said clip, said pressure transducer is adapted to measure the pressure exerted on it by the lifting and falling of the skin of the breathing person and activates said communicating means when the pressure exerted on said pressure transducer occurs in irregular intervals or ceases for a predetermined period of time, wherein said pressure transducer is sufficiently sensitive to additionally sense the heartbeat of the person and wherein an irregular heartbeat or a cessation in heartbeat is sensed, said communicating means is activated;

a temperature sensing and measuring means positionable in said clip, and wherein said temperature sensing means continuously senses and measures temperature

and activates said communicating means should the measured temperature be below or above a predetermined value;

an additional temperature sensing and measuring means which is positionable exterior the item of clothing of the person wearing said health monitoring device, wherein said values measured by said two temperature sensors is compared continuously so as to calculate the rate of heat loss of the person wearing said health monitoring device, wherein when said rate of heat loss falls below or rises above a predetermined value or value range, said communicating means is activated;

a humidity sensing and measuring means positionable in said clip, wherein when said measured humidity value rises above a certain predetermined value, said communicating means is activated;

an additional humidity sensing and measuring means positionable exterior the item of clothing of the person wearing said health monitoring device, wherein the values measured by said both humidity sensors are compared continuously so as to be able to ascertain when the humidity level between the item of clothing

and the skin of the person rises above a desired value at which stage said communicating means is activated; and

a stimulating means activated by said pressure transducer, said stimulating means being adapted to encourage the person to breathe normally prior to or simultaneously with the activating of said communicating means.

19. The health monitoring device as set forth in claim 18 further comprising an outer flexible membrane for transmitting pressure applied to said membrane to said pressure transducer.

20. The health monitoring device as set forth in claim 18 further comprising a cavity defined in said clip, an additional membrane attached to said clip covering said cavity, a port defined through said clip connecting said cavity between said membrane with an area behind said membrane, wherein said cavity and said port is filled with a fluid for transferring pressure exerted by the waistband of the item of clothing on said additional membrane to said outer flexible membrane, thereby allowing pressure from both sides of said clip to be measured.

* * * * *

专利名称(译)	用于监测人类状况的装置		
公开(公告)号	US20060258916A1	公开(公告)日	2006-11-16
申请号	US11/307361	申请日	2006-02-02
[标]申请(专利权)人(译)	彼得森JOHANNES杀敌		
申请(专利权)人(译)	彼得森JOHANNES杀敌		
当前申请(专利权)人(译)	彼得森JOHANNES德克勒克		
[标]发明人	PIETERSEN JOHANNES DE KLERK		
发明人	PIETERSEN, JOHANNES DE KLERK		
IPC分类号	A61B5/02 A61B5/00 A61B5/08 A61B5/0205 A61F13/15		
CPC分类号	A61B5/0002 A61B5/01 A61F13/84 A61B5/02055 A61B5/6804 A61B5/0205		
优先权	PCT/ZA2004/000091 2004-08-04 WO 200308285 2003-10-24 ZA 200306138 2003-08-08 ZA 200300949 2003-08-04 ZA		
其他公开文献	US7800505		
外部链接	Espacenet USPTO		

摘要(译)

一种用于连续监测与人的健康或舒适度相关的一个或多个指示器的装置12包括一个或多个用于测量一个或多个所需指示器的值的传感装置和一个在测量值高于时传达警报信号的通信装置13或者低于预定值或值范围的范围，其中装置10适于附接到人12的衣服14。

