



US010219780B2

(12) **United States Patent**
Castella et al.

(10) **Patent No.: US 10,219,780 B2**
(45) **Date of Patent: Mar. 5, 2019**

(54) **OCT-IVUS CATHETER FOR CONCURRENT LUMINAL IMAGING**

USPC 600/112, 407, 411, 427, 47, 462, 466, 600/467
See application file for complete search history.

(75) Inventors: **Paul Castella**, San Antonio, TX (US);
Nathaniel J. Kemp, Austin, TX (US);
Thomas E. Milner, Austin, TX (US);
David G. Rosenbaum, Glencoe, IL (US)

(56) **References Cited**

U.S. PATENT DOCUMENTS

3,301,258 A 1/1967 Werner
3,617,880 A 11/1971 Cormack et al.
3,789,841 A 2/1974 Antoshkiw
3,841,308 A 10/1974 Tate
4,140,364 A 2/1979 Yamashita et al.
4,274,423 A 6/1981 Mizuno et al.
4,344,438 A 8/1982 Schultz
4,398,791 A 8/1983 Dorsey
(Continued)

(73) Assignee: **Volcano Corporation**, San Diego, CA (US)

(*) Notice: Subject to any disclaimer, the term of this patent is extended or adjusted under 35 U.S.C. 154(b) by 814 days.

(21) Appl. No.: **12/173,004**

FOREIGN PATENT DOCUMENTS

(22) Filed: **Jul. 14, 2008**

EP 1041373 A2 10/2000
EP 01172637 A1 1/2002
(Continued)

(65) **Prior Publication Data**

US 2009/0043191 A1 Feb. 12, 2009

Related U.S. Application Data

OTHER PUBLICATIONS

(60) Provisional application No. 60/949,472, filed on Jul. 12, 2007, provisional application No. 60/949,511, filed on Jul. 12, 2007.

Fiber Optics, "The Basics of Fiber Optic Cable: A Tutorial", accessed online Nov. 26, 2014, available online as early as Feb. 2001.*
(Continued)

(51) **Int. Cl.**

A61B 8/12 (2006.01)
A61B 5/00 (2006.01)
A61B 5/02 (2006.01)
A61B 8/08 (2006.01)

Primary Examiner — Christopher L Cook

(52) **U.S. Cl.**

CPC **A61B 8/12** (2013.01); **A61B 5/0066** (2013.01); **A61B 5/02007** (2013.01); **A61B 5/6852** (2013.01); **A61B 8/486** (2013.01)

(57) **ABSTRACT**

The invention relates to an apparatus for in vivo imaging. More specifically, the present invention relates to a catheter that incorporates an Optical Coherence Tomography (OCT) system and an Intravascular Ultrasound ("IVUS) system for concurrent imaging of luminal systems, such as imaging the vasculature system, including, without limitation, cardiac vasculature, peripheral vasculature and neural vasculature.

(58) **Field of Classification Search**

CPC . A61B 5/0066; A61B 5/02007; A61B 5/6852; A61B 8/12; A61B 8/486

16 Claims, 4 Drawing Sheets

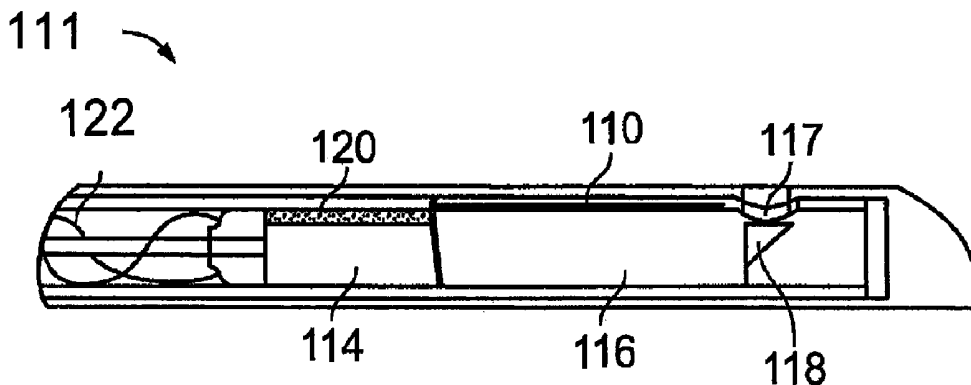

(56)

References Cited

U.S. PATENT DOCUMENTS

4,432,370 A	2/1984	Hughes et al.	5,267,954 A	12/1993	Nita
4,552,554 A	11/1985	Gould et al.	5,301,001 A	4/1994	Murphy et al.
4,577,543 A	3/1986	Wilson 87/11	5,312,425 A	5/1994	Evans et al.
4,676,980 A	6/1987	Segal et al.	5,313,949 A	5/1994	Yock
4,682,895 A	7/1987	Costello	5,313,957 A	5/1994	Little
4,733,665 A	3/1988	Palmaz	5,319,492 A	6/1994	Dorn et al.
4,744,619 A	5/1988	Cameron	5,321,501 A	6/1994	Swanson et al.
4,762,129 A	8/1988	Bonzel	5,325,198 A	6/1994	Hartley et al.
4,766,386 A	8/1988	Oliver et al.	5,336,178 A	8/1994	Kaplan et al.
4,771,774 A	9/1988	Simpson et al.	5,346,689 A	9/1994	Peyman et al.
4,794,931 A	1/1989	Yock	5,348,017 A	9/1994	Thornton et al.
4,800,886 A *	1/1989	Nestor 600/311	5,348,481 A	9/1994	Ortiz
4,803,639 A	2/1989	Steele et al.	5,353,798 A	10/1994	Sieben
4,816,567 A	3/1989	Cabilly et al.	5,358,409 A	10/1994	Obara
4,819,740 A	4/1989	Warrington	5,358,478 A	10/1994	Thompson et al.
4,821,731 A	4/1989	Martinelli et al.	5,368,037 A	11/1994	Eberle et al.
4,824,435 A	4/1989	Giesy et al.	5,373,845 A	12/1994	Gardineer et al.
4,830,023 A	5/1989	de Toledo et al.	5,373,849 A	12/1994	Maroney et al.
4,834,093 A	5/1989	Littleford et al.	5,375,602 A	12/1994	Lancee et al.
4,841,977 A	6/1989	Griffith et al.	5,377,682 A	1/1995	Ueno et al.
4,864,578 A	9/1989	Proffitt et al.	5,383,853 A	1/1995	Jung et al. 604/96
4,873,690 A	10/1989	Adams	5,387,193 A	2/1995	Miraki
4,877,314 A	10/1989	Kanamori	5,396,328 A	3/1995	Jestel et al.
4,887,606 A	12/1989	Yock et al.	5,397,355 A	3/1995	Marin et al.
4,917,085 A	4/1990	Smith	5,405,377 A	4/1995	Cragg
4,917,097 A	4/1990	Proudian et al.	5,411,016 A	5/1995	Kume et al.
4,928,693 A	5/1990	Goodin et al.	5,419,777 A	5/1995	Hoffing
4,932,413 A	6/1990	Shockey et al.	5,421,338 A	6/1995	Crowley et al.
4,932,419 A	6/1990	de Toledo	5,423,806 A	6/1995	Dale et al.
4,948,229 A	8/1990	Soref	5,427,118 A	6/1995	Nita et al.
4,951,677 A	8/1990	Crowley et al.	5,431,673 A	7/1995	Summers et al.
4,969,742 A	11/1990	Falk et al.	5,436,759 A	7/1995	Dijaili et al.
4,987,412 A	1/1991	Vaitekunas et al.	5,439,139 A	8/1995	Brovelli
4,993,412 A	2/1991	Murphy-Chutorian	5,443,457 A	8/1995	Ginn et al. 604/280
4,998,972 A	3/1991	Chin et al.	5,453,575 A	9/1995	O'Donnell et al.
5,000,185 A	3/1991	Yock	5,456,693 A	10/1995	Conston et al.
5,024,234 A	6/1991	Leary et al. 128/663.01	5,459,570 A	10/1995	Swanson et al.
5,025,445 A	6/1991	Anderson et al.	5,480,388 A	1/1996	Zadini et al.
5,032,123 A	7/1991	Katz et al.	5,485,845 A	1/1996	Verdonk et al.
5,037,169 A	8/1991	Chun	5,492,125 A	2/1996	Kim et al.
5,039,193 A	8/1991	Snow et al.	5,496,997 A	3/1996	Pope
5,040,548 A	8/1991	Yock	5,507,761 A	4/1996	Duer
5,041,108 A	8/1991	Fox et al.	5,512,044 A	4/1996	Duer
5,054,492 A	10/1991	Scribner et al.	5,514,128 A	5/1996	Hillsman et al.
5,065,010 A	11/1991	Knute	5,529,674 A	6/1996	Hedgcoth 204/298.21
5,065,769 A	11/1991	de Toledo	5,541,730 A	7/1996	Chaney
5,085,221 A *	2/1992	Ingebrigtsen et al. 600/446	5,546,717 A	8/1996	Penczak et al.
5,095,911 A	3/1992	Pomeranz	5,546,948 A	8/1996	Hamm et al.
5,100,424 A	3/1992	Jang et al.	5,565,332 A	10/1996	Hoogenboom et al.
5,120,308 A	6/1992	Hess	5,573,520 A	11/1996	Schwartz et al.
5,125,137 A	6/1992	Corl et al.	5,581,638 A	12/1996	Givens et al.
5,135,486 A	8/1992	Eberle et al.	5,586,054 A	12/1996	Jensen et al.
5,135,516 A	8/1992	Sahatjian et al.	5,592,939 A	1/1997	Martinelli
5,155,439 A	10/1992	Holmbo et al.	5,596,079 A	1/1997	Smith et al.
5,158,548 A	10/1992	Lau et al.	5,598,844 A	2/1997	Diaz et al.
5,163,445 A	11/1992	Christian et al.	5,609,606 A	3/1997	O'Boyle
5,167,233 A	12/1992	Eberle et al.	5,630,806 A	5/1997	Inagaki et al.
5,174,295 A	12/1992	Christian et al.	5,651,366 A	7/1997	Liang et al.
5,176,141 A	1/1993	Bom et al.	5,660,180 A	8/1997	Malinowski et al.
5,176,674 A	1/1993	Hofmann	5,667,499 A	9/1997	Welch et al. 604/282
5,178,159 A	1/1993	Christian	5,667,521 A	9/1997	Keown 606/194
5,183,048 A	2/1993	Eberle	5,672,877 A	9/1997	Liebig et al.
5,188,632 A	2/1993	Goldenberg	5,674,232 A	10/1997	Halliburton
5,201,316 A	4/1993	Pomeranz et al.	5,693,015 A	12/1997	Walker et al.
5,202,745 A	4/1993	Sorin et al.	5,713,848 A	2/1998	Dubrul et al.
5,203,779 A	4/1993	Muller et al.	5,745,634 A	4/1998	Garrett et al.
5,220,922 A	6/1993	Barany	5,771,895 A	6/1998	Slager
5,224,953 A	7/1993	Morgentaler	5,779,731 A	7/1998	Leavitt
5,226,421 A	7/1993	Frisbie et al.	5,780,958 A	7/1998	Strugach et al.
5,240,003 A	8/1993	Lancee et al.	5,798,521 A	8/1998	Froggatt
5,240,437 A	8/1993	Christian	5,800,450 A	9/1998	Lary et al.
5,242,460 A	9/1993	Klein et al.	5,803,083 A	9/1998	Buck et al.
5,243,988 A	9/1993	Sieben et al.	5,814,061 A	9/1998	Osborne et al.
5,257,974 A	11/1993	Cox	5,817,025 A	10/1998	Alekseev et al.
5,266,302 A	11/1993	Peyman et al.	5,820,594 A	10/1998	Fontirroche et al.
			5,824,520 A	10/1998	Mulligan-Kehoe
			5,827,313 A	10/1998	Ream
			5,830,222 A	11/1998	Makower
			5,848,121 A	12/1998	Gupta et al.

(56)		References Cited						
		U.S. PATENT DOCUMENTS						
5,851,464	A	12/1998	Davila et al.	264/103	6,364,841	B1	4/2002 White et al.	600/466
5,857,974	A	1/1999	Eberle et al.		6,366,722	B1	4/2002 Murphy et al.	
5,872,829	A	2/1999	Wischmann et al.		6,367,984	B1	4/2002 Stephenson et al.	
5,873,835	A	2/1999	Hastings et al.		6,373,970	B1	4/2002 Dong et al.	
5,882,722	A	3/1999	Kydd		6,375,615	B1	4/2002 Flaherty et al.	
5,912,764	A	6/1999	Togino		6,375,618	B1	4/2002 Chiao et al.	
5,916,194	A	6/1999	Jacobsen et al.		6,375,628	B1	4/2002 Zadno-Azizi et al.	
5,921,931	A	7/1999	O'Donnell et al.		6,376,830	B1	4/2002 Froggatt et al.	
5,925,055	A	7/1999	Adrian et al.		6,379,352	B1	4/2002 Reynolds et al.	
5,949,929	A	9/1999	Hamm		6,381,350	B1	4/2002 Klingensmith et al.	
5,951,586	A	9/1999	Berg et al.		6,387,124	B1	5/2002 Buscemi et al.	
5,974,521	A	10/1999	Akerib		6,396,976	B1	5/2002 Little et al.	
5,976,120	A	11/1999	Chow et al.	604/525	6,398,792	B1	6/2002 O'Connor	
5,978,391	A	11/1999	Das et al.		6,417,948	B1	7/2002 Chowdhury et al.	
5,997,523	A	12/1999	Jang		6,419,644	B1	7/2002 White et al.	600/585
6,021,240	A	2/2000	Murphy et al.		6,421,164	B2	7/2002 Tearney et al.	
6,022,319	A	2/2000	Willard et al.		6,423,012	B1	7/2002 Kato et al.	
6,031,071	A	2/2000	Mandeville et al.		6,426,796	B1	7/2002 Pulliam et al.	
6,036,889	A	3/2000	Kydd		6,428,041	B1	8/2002 Wohllebe et al.	
6,043,883	A	3/2000	Leckel et al.		6,428,498	B2	8/2002 Uflacker	
6,050,949	A	4/2000	White et al.	600/466	6,429,421	B1	8/2002 Meller et al.	
6,059,738	A	5/2000	Stoltze et al.		6,440,077	B1	8/2002 Jung et al.	
6,068,638	A	5/2000	Makower		6,443,903	B1	9/2002 White et al.	600/466
6,074,362	A	6/2000	Jang et al.		6,450,964	B1	9/2002 Webler	
6,078,831	A	6/2000	Belef et al.		6,457,365	B1	10/2002 Stephens et al.	
6,080,109	A	6/2000	Baker et al.		6,459,844	B1	10/2002 Pan	
6,091,496	A	7/2000	Hill		6,468,290	B1	10/2002 Weldon et al.	
6,094,591	A	7/2000	Foltz et al.		6,475,149	B1	11/2002 Sumanaweera	
6,095,976	A	8/2000	Nachtomy et al.		6,480,285	B1	11/2002 Hill	
6,097,755	A	8/2000	Guenther, Jr. et al.		6,491,631	B2	12/2002 Chiao et al.	
6,099,471	A	8/2000	Torp et al.		6,491,636	B2	12/2002 Chenal et al.	
6,099,549	A	8/2000	Bosma et al.		6,501,551	B1	12/2002 Tearney et al.	
6,102,938	A	8/2000	Evans et al.		6,504,286	B1	1/2003 Porat et al.	
6,106,476	A	8/2000	Corl et al.		6,508,824	B1	1/2003 Flaherty et al.	
6,120,445	A	9/2000	Grunwald		6,514,237	B1	2/2003 Maseda	
6,123,673	A	9/2000	Eberle et al.		6,520,269	B2	2/2003 Geiger et al.	
6,134,003	A	10/2000	Tearney et al.		6,520,677	B2	2/2003 Iizuka	
6,139,510	A	10/2000	Palermo		6,535,764	B2	3/2003 Imran et al.	
6,141,089	A	10/2000	Thoma et al.		6,538,778	B1	3/2003 Leckel et al.	
6,146,328	A	11/2000	Chiao et al.		6,544,217	B1	4/2003 Gulachenski	
6,148,095	A	11/2000	Prause et al.		6,544,230	B1	4/2003 Flaherty et al.	
6,151,433	A	11/2000	Dower et al.		6,545,760	B1	4/2003 Froggatt et al.	
6,152,877	A	11/2000	Masters		6,546,272	B1	4/2003 MacKinnon et al.	
6,152,878	A	11/2000	Nachtomy et al.		6,551,250	B2	4/2003 Khalil	
6,159,225	A	12/2000	Makower		6,566,648	B1	5/2003 Froggatt	
6,165,127	A	12/2000	Crowley		6,570,894	B2	5/2003 Anderson	
6,176,842	B1	1/2001	Tachibana et al.		6,572,555	B2	6/2003 White et al.	600/166
6,179,809	B1	1/2001	Khairkahan et al.		6,579,311	B1	6/2003 Makower	
6,186,949	B1	2/2001	Hatfield et al.		6,584,335	B1	6/2003 Haar et al.	
6,190,353	B1	2/2001	Makower et al.		6,592,612	B1	7/2003 Samson et al.	
6,200,266	B1	3/2001	Shokrollahi et al.		6,594,448	B2	7/2003 Herman et al.	
6,200,268	B1	3/2001	Vince et al.		6,602,241	B2	8/2003 Makower et al.	
6,203,537	B1	3/2001	Adrian		6,611,322	B1	8/2003 Nakayama et al.	
6,208,415	B1	3/2001	De Boer et al.		6,611,720	B2	8/2003 Hata et al.	
6,210,332	B1	4/2001	Chiao et al.		6,612,992	B1	9/2003 Hossack et al.	
6,210,339	B1	4/2001	Kiepen et al.		6,615,062	B2	9/2003 Ryan et al.	
6,212,308	B1	4/2001	Donald		6,615,072	B1	9/2003 Izatt et al.	
6,231,518	B1	5/2001	Grabek et al.		6,621,562	B2	9/2003 Durston	
6,245,066	B1	6/2001	Morgan et al.		6,631,284	B2	10/2003 Nutt et al.	
6,249,076	B1	6/2001	Madden et al.		6,638,227	B2	10/2003 Bae	
6,254,543	B1	7/2001	Grunwald et al.		6,645,152	B1	11/2003 Jung et al.	
6,256,090	B1	7/2001	Chen et al.		6,646,745	B2	11/2003 Verma et al.	
6,258,052	B1	7/2001	Milo		6,655,386	B1	12/2003 Makower et al.	
6,261,246	B1	7/2001	Pantages et al.		6,659,957	B1	12/2003 Vardi et al.	
6,275,628	B1	8/2001	Jones et al.		6,660,024	B1	12/2003 Flaherty et al.	
6,283,921	B1	9/2001	Nix et al.		6,663,565	B2	12/2003 Kawagishi et al.	
6,283,951	B1	9/2001	Flaherty et al.		6,665,456	B2	12/2003 Dave et al.	
6,295,308	B1	9/2001	Zah		6,669,716	B1	12/2003 Gilson et al.	623/1.11
6,299,622	B1	10/2001	Snow et al.		6,671,055	B1	12/2003 Wavering et al.	
6,312,384	B1	11/2001	Chiao		6,673,015	B1	1/2004 Glover et al.	
6,325,797	B1	12/2001	Stewart et al.		6,673,064	B1	1/2004 Rentrop	
6,328,696	B1	12/2001	Fraser		6,685,648	B2	2/2004 Flaherty et al.	
6,343,168	B1	1/2002	Murphy et al.		6,689,056	B1	2/2004 Kilcoyne et al.	
6,343,178	B1	1/2002	Burns et al.		6,689,144	B2	2/2004 Gerberding	606/157
6,350,240	B1	2/2002	Song et al.		6,696,173	B1	2/2004 Naundorf et al.	
					6,701,044	B2	3/2004 Arbore et al.	
					6,701,176	B1	3/2004 Halperin et al.	
					6,709,444	B1	3/2004 Makower	
					6,712,836	B1	3/2004 Berg et al.	

(56)

References Cited

U.S. PATENT DOCUMENTS

6,714,703 B2	3/2004	Lee et al.	7,175,597 B2	2/2007	Vince et al.
6,719,717 B1	4/2004	Johnson et al.	7,177,491 B2	2/2007	Dave et al.
6,725,073 B1	4/2004	Motamedi et al.	7,190,464 B2	3/2007	Alphonse
6,726,677 B1	4/2004	Flaherty et al.	7,215,802 B2	5/2007	Klingensmith et al.
6,730,107 B2	5/2004	Kelley et al.	7,218,811 B2	5/2007	Shigenaga et al.
6,733,474 B2	5/2004	Kusleika	7,236,812 B1	6/2007	Ballerstadt et al.
6,738,144 B1	5/2004	Dogariu	7,245,125 B2	7/2007	Harer et al.
6,740,113 B2	5/2004	Vrba	7,245,789 B2	7/2007	Bates et al.
6,746,464 B1	6/2004	Makower	7,249,357 B2	7/2007	Landman et al.
6,780,157 B2	8/2004	Stephens et al.	7,289,842 B2 *	10/2007	Maschke 600/478
6,795,188 B2	9/2004	Ruck et al.	7,291,146 B2	11/2007	Steinke et al.
6,795,196 B2	9/2004	Funakawa	7,292,715 B2	11/2007	Furnish
6,798,522 B2	9/2004	Stolte et al.	7,292,885 B2	11/2007	Scott et al.
6,822,798 B2	11/2004	Wu et al.	7,294,124 B2	11/2007	Eidenschink
6,830,559 B2	12/2004	Schock	7,300,460 B2	11/2007	Levine et al.
6,832,024 B2	12/2004	Gerstenberger et al.	7,335,161 B2	2/2008	Von Arx et al.
6,842,639 B1	1/2005	Winston et al.	7,337,079 B2	2/2008	Park et al.
6,847,449 B2	1/2005	Bashkansky et al.	7,355,716 B2	4/2008	de Boer et al.
6,855,115 B2	2/2005	Fonseca et al.	7,356,367 B2	4/2008	Liang et al.
6,856,138 B2	2/2005	Bohley	7,358,921 B2	4/2008	Snyder et al.
6,856,400 B1	2/2005	Froggatt	7,359,062 B2	4/2008	Chen et al.
6,856,472 B2	2/2005	Herman et al.	7,359,554 B2	4/2008	Klingensmith et al.
6,860,867 B2	3/2005	Seward et al.	7,363,927 B2	4/2008	Ravikummar
6,866,670 B2	3/2005	Rabiner et al.	7,366,376 B2	4/2008	Shishkov et al.
6,878,113 B2	4/2005	Miwa et al.	7,382,949 B2	6/2008	Bouma et al.
6,886,411 B2	5/2005	Kjellman et al.	7,387,636 B2	6/2008	Cohn et al.
6,891,984 B2	5/2005	Petersen et al.	7,391,520 B2	6/2008	Zhou et al.
6,895,106 B2	5/2005	Wang et al.	7,397,935 B2	7/2008	Kimmel et al.
6,898,337 B2	5/2005	Averett et al.	7,399,095 B2	7/2008	Rondinelli
6,900,897 B2	5/2005	Froggatt	7,408,648 B2	8/2008	Kleen et al.
6,912,051 B2	6/2005	Jensen	7,414,779 B2	8/2008	Huber et al.
6,916,329 B1 *	7/2005	Zhao 606/189	7,440,087 B2	10/2008	Froggatt et al.
6,922,498 B2	7/2005	Shah	7,447,388 B2	11/2008	Bates et al.
6,937,346 B2	8/2005	Nebendahl et al.	7,449,821 B2	11/2008	Dausch
6,937,696 B1	8/2005	Mostafavi	7,450,165 B2	11/2008	Ahiska
6,943,939 B1	9/2005	DiJaili et al.	RE40,608 E	12/2008	Glover et al.
6,947,147 B2	9/2005	Motamedi et al.	7,458,967 B2	12/2008	Appling et al.
6,947,787 B2	9/2005	Webler	7,463,362 B2	12/2008	Lasker et al.
6,949,094 B2	9/2005	Yaron	7,463,759 B2	12/2008	Klingensmith et al.
6,952,603 B2	10/2005	Gerber et al.	7,491,226 B2	2/2009	Palmaz et al.
6,954,737 B2	10/2005	Kalantar et al.	7,515,276 B2	4/2009	Froggatt et al.
6,958,042 B2	10/2005	Honda	7,527,594 B2	5/2009	Vardi et al.
6,961,123 B1	11/2005	Wang et al.	7,534,251 B2	5/2009	WasDyke
6,966,891 B2	11/2005	Ookubo et al. 604/103.04	7,535,797 B2	5/2009	Peng et al.
6,969,293 B2	11/2005	Thai	7,547,304 B2	6/2009	Johnson
6,969,395 B2	11/2005	Eskuri	7,564,949 B2	7/2009	Sattler et al.
6,985,234 B2	1/2006	Anderson	7,577,471 B2	8/2009	Camus et al.
7,004,963 B2	2/2006	Wang et al.	7,583,857 B2	9/2009	Xu et al.
7,006,231 B2	2/2006	Ostrovsky et al. 356/479	7,603,165 B2	10/2009	Townsend et al.
7,010,458 B2	3/2006	Wilt	7,612,773 B2	11/2009	Magnin et al.
7,024,025 B2	4/2006	Sathyanarayana	7,633,627 B2	12/2009	Choma et al.
7,027,211 B1	4/2006	Ruffa	7,645,229 B2	1/2010	Armstrong
7,027,743 B1	4/2006	Tucker et al.	7,658,715 B2	2/2010	Park et al.
7,033,347 B2	4/2006	Appling	7,660,452 B2	2/2010	Zwirn et al.
7,035,484 B2	4/2006	Silberberg et al.	7,660,492 B2	2/2010	Bates et al.
7,037,269 B2	5/2006	Nix et al.	7,666,204 B2	2/2010	Thornton et al.
7,042,573 B2	5/2006	Froggatt	7,672,790 B2	3/2010	McGraw et al.
7,044,915 B2	5/2006	White et al. 600/459	7,680,247 B2	3/2010	Atzinger et al.
7,044,964 B2	5/2006	Jang et al.	7,684,991 B2	3/2010	Stohr et al.
7,048,711 B2	5/2006	Rosenman et al.	7,711,413 B2	5/2010	Feldman et al.
7,049,306 B2	5/2006	Konradi et al.	7,720,322 B2	5/2010	Prisco
7,058,239 B2	6/2006	Singh et al.	7,728,986 B2	6/2010	Lasker et al.
7,060,033 B2	6/2006	White et al.	7,734,009 B2	6/2010	Brunner et al.
7,060,421 B2	6/2006	Naundorf et al.	7,736,317 B2	6/2010	Stephens et al.
7,063,679 B2	6/2006	Maguire et al.	7,742,795 B2	6/2010	Stone et al.
7,068,852 B2	6/2006	Braica	7,743,189 B2	6/2010	Brown et al.
7,074,188 B2	7/2006	Nair et al.	7,762,954 B2	7/2010	Nix et al.
7,095,493 B2	8/2006	Harres	7,766,896 B2	8/2010	Kornkven Volk et al.
7,110,119 B2	9/2006	Maestle	7,773,792 B2	8/2010	Kimmel et al.
7,113,875 B2	9/2006	Terashima et al.	7,775,981 B1	8/2010	Guracar et al.
7,123,777 B2	10/2006	Rondinelli et al.	7,777,399 B2	8/2010	Eidenschink et al.
7,130,054 B2	10/2006	Ostrovsky et al. 356/479	7,781,724 B2	8/2010	Childers et al.
7,139,440 B2	11/2006	Rondinelli et al.	7,783,337 B2	8/2010	Feldman et al.
7,153,299 B1	12/2006	Tu et al.	7,787,127 B2	8/2010	Galle et al.
7,171,078 B2	1/2007	Sasaki et al.	7,792,342 B2	9/2010	Barbu et al.
			7,801,343 B2	9/2010	Unal et al.
			7,801,590 B2	9/2010	Feldman et al.
			7,813,609 B2	10/2010	Petersen et al.
			7,831,081 B2	11/2010	Li

(56)

References Cited

U.S. PATENT DOCUMENTS

7,846,101	B2	12/2010	Eberle et al.	8,301,000	B2	10/2012	Sillard et al.
7,853,104	B2	12/2010	Oota et al.	8,309,428	B2	11/2012	Lemmerhirt et al.
7,853,316	B2	12/2010	Milner et al.	8,317,713	B2	11/2012	Davies et al.
7,860,555	B2	12/2010	Saadat	8,323,201	B2	12/2012	Towfiq et al.
7,862,508	B2	1/2011	Davies et al.	8,329,053	B2	12/2012	Martin et al.
7,872,759	B2	1/2011	Tearney et al.	8,336,643	B2	12/2012	Harleman
7,880,868	B2	2/2011	Aoki	8,349,000	B2	1/2013	Schreck
7,881,763	B2	2/2011	Brauker et al.	8,353,945	B2	1/2013	Andreas et al.
7,909,844	B2	3/2011	Alkhatib et al.	8,353,954	B2	1/2013	Cai et al.
7,921,854	B2	4/2011	Hennings et al.	8,357,981	B2	1/2013	Martin et al.
7,927,784	B2	4/2011	Simpson	8,361,097	B2	1/2013	Patel et al.
7,929,148	B2	4/2011	Kemp	8,386,560	B2	2/2013	Ma et al.
7,930,014	B2	4/2011	Huennekens et al.	8,398,591	B2	3/2013	Mas et al.
7,930,104	B2	4/2011	Baker et al.	8,412,312	B2	4/2013	Judell et al.
7,936,462	B2	5/2011	Jiang et al.	8,417,491	B2	4/2013	Trovato et al.
7,942,852	B2	5/2011	Mas et al.	8,449,465	B2	5/2013	Nair et al.
7,947,012	B2	5/2011	Spurchise et al.	8,454,685	B2	6/2013	Hariton et al.
7,951,186	B2	5/2011	Eidenschink et al.	8,454,686	B2	6/2013	Alkhatib
7,952,719	B2	5/2011	Brennan, III	8,475,522	B2	7/2013	Jimenez et al.
7,972,353	B2	7/2011	Hendriksen et al.	8,478,384	B2	7/2013	Schmitt et al.
7,976,492	B2	7/2011	Brauker et al.	8,486,062	B2	7/2013	Belhe et al.
7,977,950	B2	7/2011	Maslen	8,486,063	B2	7/2013	Werneth et al.
7,978,916	B2	7/2011	Klingensmith et al.	8,491,567	B2	7/2013	Magnin et al.
7,981,041	B2	7/2011	McGahan	8,500,798	B2	8/2013	Rowe et al.
7,981,151	B2	7/2011	Rowe	8,550,911	B2	10/2013	Sylla
7,983,737	B2	7/2011	Feldman et al.	8,594,757	B2	11/2013	Boppart et al.
7,993,333	B2	8/2011	Oral et al.	8,597,349	B2	12/2013	Alkhatib
7,995,210	B2	8/2011	Tearney et al.	8,600,477	B2	12/2013	Beyar et al.
7,996,060	B2	8/2011	Trofimov et al.	8,600,917	B1	12/2013	Schimert et al.
7,999,938	B2	8/2011	Wang	8,601,056	B2	12/2013	Lauwers et al.
8,021,377	B2	9/2011	Eskuri	8,620,055	B2	12/2013	Barratt et al.
8,021,420	B2	9/2011	Dolan	8,644,910	B2	2/2014	Rouso et al.
8,036,732	B2	10/2011	Milner	2001/0007940	A1	7/2001	Tu et al.
8,040,586	B2	10/2011	Smith et al.	2001/0029337	A1	10/2001	Pantages et al.
8,047,996	B2	11/2011	Goodnow et al.	2001/0037073	A1	11/2001	White et al. 600/585
8,049,900	B2	11/2011	Kemp et al.	2001/0046345	A1	11/2001	Snyder et al.
8,050,478	B2	11/2011	Li et al.	2001/0049548	A1	12/2001	Vardi et al.
8,050,523	B2	11/2011	Younge et al.	2002/0034276	A1	3/2002	Hu et al.
8,052,605	B2	11/2011	Muller et al.	2002/0041723	A1	4/2002	Ronnekleiv et al.
8,057,394	B2	11/2011	Dala-Krishna	2002/0069676	A1	6/2002	Kopp et al.
8,059,923	B2	11/2011	Bates et al.	2002/0089335	A1	7/2002	Williams
8,070,800	B2	12/2011	Lock et al.	2002/0099289	A1	7/2002	Crowley
8,080,800	B2	12/2011	Hector et al.	2002/0163646	A1	11/2002	Anderson
8,088,102	B2	1/2012	Adams et al.	2002/0186818	A1	12/2002	Arnaud et al.
8,100,838	B2	1/2012	Wright et al.	2002/0196446	A1	12/2002	Roth et al.
8,104,479	B2	1/2012	Glynn et al.	2002/0197456	A1	12/2002	Pope
8,108,030	B2	1/2012	Castella et al.	2003/0004412	A1	1/2003	Izatt et al.
8,114,102	B2	2/2012	Galdonik et al.	2003/0016604	A1	1/2003	Hanes
8,116,605	B2	2/2012	Petersen et al.	2003/0018273	A1	1/2003	Corl et al.
8,125,648	B2	2/2012	Milner et al.	2003/0023153	A1	1/2003	Izatt et al.
8,126,239	B2	2/2012	Sun et al.	2003/0032886	A1	2/2003	Dgany et al.
8,133,199	B2	3/2012	Weber et al.	2003/0050871	A1	3/2003	Broughton
8,133,269	B2	3/2012	Flechsengar et al.	2003/0065371	A1	4/2003	Satake
8,140,708	B2	3/2012	Zaharia et al.	2003/0069723	A1	4/2003	Hegde
8,148,877	B2	4/2012	Jiang et al.	2003/0077043	A1*	4/2003	Hamm et al. 385/72
8,167,932	B2	5/2012	Bourang et al.	2003/0085635	A1	5/2003	Davidson
8,172,757	B2	5/2012	Jaffe et al.	2003/0090753	A1	5/2003	Takeyama et al.
8,177,809	B2	5/2012	Mavani et al.	2003/0092995	A1	5/2003	Thompson
8,187,191	B2	5/2012	Hancock et al.	2003/0093059	A1	5/2003	Griffin et al.
8,187,267	B2	5/2012	Pappone et al.	2003/0103212	A1	6/2003	Westphal et al.
8,187,830	B2	5/2012	Hu et al.	2003/0152259	A1	8/2003	Belykh et al.
8,199,218	B2	6/2012	Lee et al.	2003/0181802	A1	9/2003	Ogawa
8,206,429	B2	6/2012	Gregorich et al.	2003/0187369	A1	10/2003	Lewis et al.
8,208,995	B2	6/2012	Tearney et al.	2003/0194165	A1	10/2003	Silberberg et al.
8,222,906	B2	7/2012	Wyar et al.	2003/0195419	A1	10/2003	Harada
8,233,681	B2	7/2012	Aylward et al.	2003/0208116	A1	11/2003	Liang et al.
8,233,718	B2	7/2012	Klingensmith et al.	2003/0212491	A1	11/2003	Mitchell et al.
8,238,624	B2	8/2012	Doi et al.	2003/0219202	A1	11/2003	Loeb et al.
8,239,938	B2	8/2012	Simeral et al.	2003/0220749	A1	11/2003	Chen et al.
8,277,386	B2	10/2012	Ahmed et al.	2003/0228039	A1	12/2003	Green
8,280,470	B2	10/2012	Milner et al.	2004/0015065	A1	1/2004	Panescu et al.
8,289,284	B2	10/2012	Glynn et al.	2004/0023317	A1	2/2004	Motamedi et al.
8,289,522	B2	10/2012	Tearney et al.	2004/0028333	A1	2/2004	Lomas
8,298,147	B2	10/2012	Huennekens et al.	2004/0037742	A1	2/2004	Jen et al.
8,298,149	B2	10/2012	Hastings et al.	2004/0042066	A1	3/2004	Kinoshita et al.
				2004/0054287	A1	3/2004	Stephens
				2004/0067000	A1	4/2004	Bates et al.
				2004/0068161	A1	4/2004	Couvillon
				2004/0082844	A1	4/2004	Vardi et al.

(56)		References Cited	
U.S. PATENT DOCUMENTS			
2004/0092830	A1	5/2004	Scott et al. 600/478
2004/0106853	A1	6/2004	Moriyama
2004/0111552	A1	6/2004	Arimilli et al.
2004/0126048	A1	7/2004	Dave et al.
2004/0143160	A1	7/2004	Couvillon
2004/0146546	A1	7/2004	Gravett et al.
2004/0186369	A1	9/2004	Lam
2004/0186558	A1	9/2004	Pavcnik et al.
2004/0195512	A1	10/2004	Crosetto
2004/0220606	A1	11/2004	Goshgarian
2004/0225220	A1	11/2004	Rich
2004/0239938	A1	12/2004	Izatt
2004/0242990	A1 *	12/2004	Brister et al. 600/407
2004/0248439	A1	12/2004	Gernhardt et al.
2004/0260236	A1	12/2004	Manning et al.
2005/0013778	A1	1/2005	Green et al.
2005/0031176	A1	2/2005	Hertel et al.
2005/0036150	A1	2/2005	Izatt et al.
2005/0078317	A1	4/2005	Law et al.
2005/0101859	A1	5/2005	Maschke 600/427
2005/0140582	A1	6/2005	Lee et al.
2005/0140682	A1	6/2005	Sumanaweera et al.
2005/0140981	A1	6/2005	Waelti
2005/0140984	A1	6/2005	Hitzenberger
2005/0147303	A1	7/2005	Zhou et al.
2005/0165439	A1	7/2005	Weber et al.
2005/0171433	A1	8/2005	Boppart et al.
2005/0171438	A1	8/2005	Chen et al.
2005/0182297	A1	8/2005	Gravenstein et al.
2005/0196028	A1	9/2005	Kleen et al.
2005/0197585	A1	9/2005	Brockway et al.
2005/0213103	A1	9/2005	Everett et al.
2005/0215942	A1	9/2005	Abrahamson et al.
2005/0234445	A1	10/2005	Conquergood et al.
2005/0243322	A1	11/2005	Lasker et al.
2005/0249391	A1	11/2005	Kimmel et al.
2005/0251567	A1	11/2005	Ballew et al.
2005/0254059	A1	11/2005	Alphonse
2005/0264823	A1	12/2005	Zhu et al.
2006/0013523	A1	1/2006	Childlers et al.
2006/0015126	A1	1/2006	Sher
2006/0029634	A1	2/2006	Berg et al.
2006/0036167	A1	2/2006	Shina
2006/0038115	A1	2/2006	Maas
2006/0039004	A1	2/2006	de Boer et al.
2006/0041180	A1	2/2006	Viswanathan et al.
2006/0045536	A1	3/2006	Arahira
2006/0055936	A1	3/2006	Yun et al.
2006/0058622	A1	3/2006	Tearney et al.
2006/0064009	A1	3/2006	Webler et al. 600/434
2006/0067620	A1	3/2006	Shishkov et al.
2006/0072808	A1	4/2006	Grimm et al.
2006/0074318	A1 *	4/2006	Ahmed et al. 600/465
2006/0074442	A1	4/2006	Noriega et al.
2006/0098927	A1	5/2006	Schmidt et al.
2006/0100694	A1	5/2006	Globerman
2006/0106375	A1	5/2006	Werneth et al.
2006/0132790	A1	6/2006	Gutin
2006/0135870	A1 *	6/2006	Webler 600/431
2006/0142703	A1	6/2006	Carter et al. 604/264
2006/0142733	A1	6/2006	Forsberg
2006/0173299	A1	8/2006	Romley et al.
2006/0179255	A1	8/2006	Yamazaki
2006/0184048	A1	8/2006	Saadat
2006/0187537	A1	8/2006	Huber et al.
2006/0195269	A1	8/2006	Yeatman et al.
2006/0204119	A1	9/2006	Feng et al.
2006/0229591	A1	10/2006	Lee 606/1
2006/0239312	A1	10/2006	Kewitsch et al.
2006/0241342	A1	10/2006	Macaulay et al.
2006/0241465	A1	10/2006	Huennekens et al.
2006/0241503	A1	10/2006	Schmitt et al.
2006/0244973	A1	11/2006	Yun et al.
2006/0258895	A1 *	11/2006	Maschke 600/1
2006/0264743	A1	11/2006	Kleen et al.
2006/0267756	A1	11/2006	Kates
2006/0270976	A1	11/2006	Savage et al.
2006/0276709	A1 *	12/2006	Khamene et al. 600/416
2006/0279742	A1	12/2006	Tearney et al.
2006/0279743	A1	12/2006	Boesser et al.
2006/0285638	A1	12/2006	Boese et al.
2006/0287595	A1	12/2006	Maschke
2006/0293597	A1	12/2006	Johnson et al.
2007/0015969	A1	1/2007	Feldman et al.
2007/0016029	A1	1/2007	Donaldson et al.
2007/0016034	A1	1/2007	Donaldson
2007/0016062	A1	1/2007	Park et al. 600/459
2007/0027390	A1	2/2007	Maschke et al.
2007/0036417	A1	2/2007	Argiro et al.
2007/0038061	A1	2/2007	Huennekens et al.
2007/0038121	A1	2/2007	Feldman et al.
2007/0038125	A1	2/2007	Kleen et al.
2007/0043292	A1	2/2007	Camus et al. 600/443
2007/0043597	A1	2/2007	Donaldson
2007/0049847	A1	3/2007	Osborne
2007/0060973	A1	3/2007	Ludvig et al.
2007/0065077	A1	3/2007	Childers et al.
2007/0066888	A1	3/2007	Maschke 600/424
2007/0066890	A1	3/2007	Maschke 600/424
2007/0066983	A1	3/2007	Maschke 606/159
2007/0084995	A1	4/2007	Newton et al.
2007/0100226	A1	5/2007	Yankelevitz et al.
2007/0135887	A1	6/2007	Maschke
2007/0142707	A1	6/2007	Wiklof et al.
2007/0156019	A1	7/2007	Larkin et al.
2007/0161893	A1	7/2007	Milner et al.
2007/0161896	A1	7/2007	Adachi et al.
2007/0161963	A1	7/2007	Smalling
2007/0162860	A1	7/2007	Muralidharan et al.
2007/0165141	A1	7/2007	Srinivas et al.
2007/0167710	A1	7/2007	Unal et al.
2007/0167804	A1	7/2007	Park et al.
2007/0167813	A1 *	7/2007	Lee A61B 8/12 600/459
2007/0179487	A1 *	8/2007	Tearney A61B 5/0066 606/15
2007/0191682	A1	8/2007	Rolland et al.
2007/0201736	A1	8/2007	Klingensmith et al.
2007/0206193	A1	9/2007	Pesach
2007/0208276	A1	9/2007	Kornkven Volk et al.
2007/0225220	A1	9/2007	Ming et al.
2007/0225590	A1	9/2007	Ramos
2007/0229801	A1	10/2007	Tearney et al.
2007/0232872	A1	10/2007	Prough et al.
2007/0232874	A1	10/2007	Ince
2007/0232890	A1	10/2007	Hirota
2007/0232891	A1	10/2007	Hirota
2007/0232892	A1	10/2007	Hirota
2007/0232893	A1	10/2007	Tanioka
2007/0232933	A1	10/2007	Gille et al.
2007/0238957	A1	10/2007	Yared
2007/0244391	A1 *	10/2007	Hirota A61B 5/0066 600/443
2007/0247033	A1	10/2007	Eidenschink et al.
2007/0250000	A1	10/2007	Magnin et al.
2007/0250036	A1	10/2007	Volk et al.
2007/0258094	A1	11/2007	Izatt et al.
2007/0260138	A1	11/2007	Feldman et al.
2007/0278389	A1	12/2007	Ajgaonkar et al.
2007/0287914	A1	12/2007	Cohen
2008/0002183	A1	1/2008	Yatagai et al.
2008/0013093	A1	1/2008	Izatt et al.
2008/0021275	A1	1/2008	Tearney et al.
2008/0027481	A1	1/2008	Gilson et al.
2008/0043024	A1	2/2008	Schiwietz et al.
2008/0045842	A1 *	2/2008	Furnish 600/478
2008/0051660	A1	2/2008	Kakadaris et al.
2008/0063304	A1	3/2008	Russak et al.
2008/0085041	A1	4/2008	Breeuwer
2008/0095465	A1	4/2008	Mullick et al.
2008/0095714	A1	4/2008	Castella et al.
2008/0097194	A1	4/2008	Milner 600/425
2008/0101667	A1	5/2008	Begelman et al.
2008/0108867	A1	5/2008	Zhou

(56)

References Cited

U.S. PATENT DOCUMENTS

2008/0114254	A1	5/2008	Matcovitch et al.	2010/0125238	A1	5/2010	Lye et al.
2008/0119739	A1	5/2008	Vardi et al.	2010/0125268	A1	5/2010	Gustus et al.
2008/0124495	A1	5/2008	Horn et al.	2010/0125648	A1	5/2010	Zaharia et al.
2008/0125772	A1	5/2008	Stone et al.	2010/0128348	A1	5/2010	Taverner
2008/0139897	A1	6/2008	Ainsworth et al.	2010/0152717	A1	6/2010	Keeler
2008/0143707	A1	6/2008	Mitchell	2010/0160788	A1	6/2010	Davies et al.
2008/0146941	A1	6/2008	Dala-Krishna	2010/0161023	A1	6/2010	Cohen et al.
2008/0147111	A1	6/2008	Johnson et al.	2010/0168714	A1	7/2010	Burke et al.
2008/0154128	A1	6/2008	Milner	2010/0179421	A1	7/2010	Tupin
2008/0161696	A1	7/2008	Schmitt et al. 600/467	2010/0179426	A1	7/2010	Davies et al.
2008/0171944	A1	7/2008	Brenneman et al.	2010/0220334	A1	9/2010	Condit et al.
2008/0175465	A1	7/2008	Jiang et al.	2010/0226607	A1	9/2010	Zhang et al.
2008/0177183	A1	7/2008	Courtney et al.	2010/0234736	A1	9/2010	Corl
2008/0180683	A1	7/2008	Kemp	2010/0249601	A1	9/2010	Courtney
2008/0181477	A1	7/2008	Izatt et al.	2010/0256616	A1	10/2010	Katoh et al.
2008/0187201	A1	8/2008	Liang et al.	2010/0272432	A1	10/2010	Johnson
2008/0228086	A1*	9/2008	Ilegbusi et al. 600/479	2010/0284590	A1	11/2010	Peng et al.
2008/0247622	A1	10/2008	Aylward et al.	2010/0290693	A1	11/2010	Cohen et al.
2008/0247716	A1*	10/2008	Thomas et al. 385/101	2010/0331950	A1	12/2010	Strommer
2008/0262470	A1	10/2008	Lee et al.	2011/0010925	A1	1/2011	Nix et al.
2008/0262489	A1	10/2008	Steinke	2011/0021926	A1	1/2011	Spencer et al.
2008/0269599	A1	10/2008	Csavoy et al.	2011/0025853	A1	2/2011	Richardson
2008/0281205	A1	11/2008	Naghavi et al.	2011/0026797	A1	2/2011	Declerck et al.
2008/0281248	A1	11/2008	Angheloiu et al.	2011/0032533	A1	2/2011	Izatt et al.
2008/0285043	A1	11/2008	Fercher et al.	2011/0034801	A1	2/2011	Baumgart
2008/0287795	A1	11/2008	Klingensmith et al.	2011/0044546	A1	2/2011	Pan et al.
2008/0291463	A1	11/2008	Milner et al.	2011/0066073	A1	3/2011	Kuiper et al.
2008/0292173	A1	11/2008	Hsieh et al.	2011/0071401	A1	3/2011	Hastings et al.
2008/0294034	A1	11/2008	Krueger et al.	2011/0072405	A1	3/2011	Chen et al.
2008/0298655	A1	12/2008	Edwards	2011/0077528	A1	3/2011	Kemp et al.
2008/0306766	A1	12/2008	Ozeki et al.	2011/0080591	A1	4/2011	Johnson et al.
2009/0009801	A1	1/2009	Tabuki	2011/0087104	A1	4/2011	Moore et al.
2009/0018393	A1	1/2009	Dick et al.	2011/0137140	A1	6/2011	Tearney et al.
2009/0034813	A1	2/2009	Dikmen et al.	2011/0144502	A1	6/2011	Zhou et al.
2009/0043191	A1	2/2009	Castella et al.	2011/0152771	A1	6/2011	Milner et al.
2009/0046295	A1	2/2009	Kemp et al.	2011/0157597	A1	6/2011	Lu et al.
2009/0052614	A1	2/2009	Hempel et al.	2011/0160586	A1	6/2011	Li et al.
2009/0069843	A1	3/2009	Agnew	2011/0178413	A1	7/2011	Schmitt et al.
2009/0079993	A1	3/2009	Yatagai et al.	2011/0190586	A1	8/2011	Kemp
2009/0088650	A1	4/2009	Corl	2011/0216378	A1	9/2011	Poon et al.
2009/0093980	A1	4/2009	Kemp et al.	2011/0220985	A1	9/2011	Son et al.
2009/0122320	A1	5/2009	Petersen et al.	2011/0238061	A1	9/2011	van der Weide et al.
2009/0138544	A1	5/2009	Wegenkittl et al.	2011/0238083	A1	9/2011	Moll et al.
2009/0149739	A9*	6/2009	Maschke 600/424	2011/0245669	A1	10/2011	Zhang
2009/0156941	A1	6/2009	Moore	2011/0249094	A1	10/2011	Wang et al.
2009/0174886	A1	7/2009	Inoue	2011/0257545	A1	10/2011	Suri
2009/0174931	A1	7/2009	Huber et al.	2011/0264125	A1	10/2011	Wilson et al.
2009/0177090	A1	7/2009	Grunwald et al.	2011/0274329	A1	11/2011	Mathew et al.
2009/0177183	A1	7/2009	Pinkernell et al.	2011/0282334	A1	11/2011	Groenhoff
2009/0195514	A1	8/2009	Glynn et al.	2011/0301684	A1	12/2011	Fischell et al.
2009/0196470	A1	8/2009	Carl et al.	2011/0306995	A1	12/2011	Moberg
2009/0198125	A1	8/2009	Nakabayashi et al.	2011/0319752	A1	12/2011	Steinberg et al.
2009/0203991	A1*	8/2009	Papaioannou et al. 600/421	2012/0004529	A1	1/2012	Tolkowsky et al.
2009/0264768	A1	10/2009	Courtney et al.	2012/0004668	A1	1/2012	Wallace et al.
2009/0269014	A1	10/2009	Winberg et al.	2012/0013914	A1	1/2012	Kemp et al.
2009/0270695	A1	10/2009	McEowen	2012/0016344	A1	1/2012	Kusakabe
2009/0284322	A1	11/2009	Harrison et al.	2012/0016395	A1	1/2012	Olson
2009/0284332	A1	11/2009	Moore et al.	2012/0022360	A1	1/2012	Kemp
2009/0284749	A1	11/2009	Johnson et al.	2012/0026503	A1	2/2012	Lewandowski et al.
2009/0290167	A1	11/2009	Flanders et al.	2012/0029007	A1	2/2012	Graham et al.
2009/0292048	A1	11/2009	Li et al.	2012/0059253	A1	3/2012	Wang et al.
2009/0299195	A1	12/2009	Muller et al.	2012/0059368	A1	3/2012	Takaoka et al.
2009/0299284	A1	12/2009	Holman et al.	2012/0062843	A1	3/2012	Ferguson et al.
2009/0318951	A1	12/2009	Kashkarov et al.	2012/0065481	A1	3/2012	Hunter et al.
2009/0326634	A1	12/2009	Vardi	2012/0071823	A1	3/2012	Chen
2010/0007669	A1	1/2010	Bethune et al.	2012/0071838	A1	3/2012	Fojtik
2010/0030042	A1	2/2010	Denninghoff et al.	2012/0075638	A1	3/2012	Rollins et al.
2010/0061611	A1	3/2010	Xu et al.	2012/0083696	A1	4/2012	Kitamura
2010/0063400	A1	3/2010	Hall et al.	2012/0095340	A1	4/2012	Smith
2010/0087732	A1	4/2010	Eberle et al.	2012/0095372	A1	4/2012	Sverdlik et al.
2010/0094125	A1	4/2010	Younge et al.	2012/0108943	A1	5/2012	Bates et al.
2010/0094127	A1	4/2010	Xu	2012/0113108	A1	5/2012	Dala-Krishna
2010/0094135	A1	4/2010	Fang-Yen et al.	2012/0116353	A1	5/2012	Arnold et al.
2010/0094143	A1	4/2010	Mahapatra et al.	2012/0130243	A1	5/2012	Balocco et al.
2010/0113919	A1	5/2010	Maschke	2012/0130247	A1	5/2012	Waters et al.
				2012/0136259	A1	5/2012	Milner et al.
				2012/0136427	A1	5/2012	Palmaz et al.
				2012/0137075	A1	5/2012	Vorbach
				2012/0155734	A1	6/2012	Barratt et al.

(56)

References Cited

FOREIGN PATENT DOCUMENTS

U.S. PATENT DOCUMENTS			FOREIGN PATENT DOCUMENTS		
			EP	2178442 A1	4/2010
			EP	2438877 A2	4/2012
			GB	2280261 A	1/1995
			JP	2000-037355 A	2/2000
			JP	2000-262461 A	9/2000
			JP	2000-292260 A	10/2000
			JP	2000-329534 A	11/2000
			JP	2001-125009 A	5/2001
			JP	2001-272331 A	10/2001
			JP	2002-503134 A	1/2002
			JP	2002-088660 A	3/2002
			JP	2002-523162 A	7/2002
			JP	2002-374034 A	12/2002
			JP	2003-143783 A	5/2003
			JP	2003-172690 A	6/2003
			JP	2003-256876 A	9/2003
			JP	2003-287534 A	10/2003
			JP	2004-004080 A	1/2004
			JP	2004-510132 A	4/2004
			JP	2004-528111 A	9/2004
			JP	2005-274380 A	10/2005
			JP	2005-533610 A	11/2005
			JP	2006-184284 A	7/2006
			JP	2006-266797 A	10/2006
			JP	2006-313158 A	11/2006
			JP	2007-510143 A	4/2007
			JP	2009-233001 A	10/2009
			JP	2009-536425 A	10/2009
			JP	2010-516302 A	5/2010
			JP	2010-516304 A	5/2010
			JP	2011-056786 A	3/2011
			JP	2011-508677 A	3/2011
			JP	2013-546256 A	12/2013
			JP	2014-501163 A	1/2014
			JP	2014-506806 A	3/2014
			WO	91/01156 A1	2/1991
			WO	92/16865 A1	10/1992
			WO	93/06213 A1	4/1993
			WO	93/08829 A1	5/1993
			WO	1998/38907 A1	9/1998
			WO	1998/57583 A1	12/1998
			WO	00/11511 A1	3/2000
			WO	2000/11511 A1	3/2000
			WO	2000/044296 A1	8/2000
			WO	2001/11409 A2	2/2001
			WO	2003/032936 A1	4/2003
			WO	2003/062802 A2	7/2003
			WO	03/073950 A1	9/2003
			WO	2004/010856 A1	2/2004
			WO	2004/023992	3/2004
			WO	2004/096049 A2	11/2004
			WO	2005/047813 A1	5/2005
			WO	2005/106695 A2	11/2005
			WO	2006/016434 A1	2/2006
			WO	2006/029634 A2	3/2006
			WO	2006/037132 A1	4/2006
			WO	2006/039091 A2	4/2006
			WO	2006/061829 A1	6/2006
			WO	2006/068875 A2	6/2006
			WO	2006/111704 A1	10/2006
			WO	2006/119416 A2	11/2006
			WO	2006/121851 A2	11/2006
			WO	2006/119416	11/2006
			WO	2006/130802 A2	12/2006
			WO	2007/002685 A2	1/2007
			WO	2007/025230	3/2007
			WO	2007/045690 A1	4/2007
			WO	2007/058895 A2	5/2007
			WO	2007/060973 A1	5/2007
			WO	2007/067323 A2	6/2007
			WO	2007/084995 A2	7/2007
			WO	2008/058084 A2	5/2008
			WO	2008/069991 A1	6/2008
			WO	2008/107905 A2	9/2008
			WO	2009/009799 A1	1/2009
			WO	2009/009801 A1	1/2009
			WO	2009/046431 A1	4/2009
2012/0158101 A1	6/2012	Stone et al.			
2012/0162660 A1	6/2012	Kemp			
2012/0165661 A1	6/2012	Kemp et al.			
2012/0170848 A1	7/2012	Kemp et al.			
2012/0172698 A1	7/2012	Teo et al.			
2012/0176607 A1	7/2012	Ott			
2012/0184853 A1	7/2012	Waters			
2012/0184859 A1	7/2012	Shah et al.			
2012/0184977 A1	7/2012	Wolf			
2012/0215094 A1	8/2012	Rahimian et al.			
2012/0220836 A1	8/2012	Alpert et al.			
2012/0220851 A1	8/2012	Razansky et al.			
2012/0220865 A1	8/2012	Brown et al.			
2012/0220874 A1	8/2012	Hancock et al.			
2012/0220883 A1	8/2012	Manstrom et al.			
2012/0224751 A1	9/2012	Kemp et al.			
2012/0226153 A1	9/2012	Brown et al.			
2012/0230565 A1	9/2012	Steinberg et al.			
2012/0232400 A1	9/2012	Dickinson et al.			
2012/0238869 A1	9/2012	Schmitt et al.			
2012/0238956 A1	9/2012	Yamada et al.			
2012/0244043 A1	9/2012	Leblanc et al.			
2012/0250028 A1	10/2012	Schmitt et al.			
2012/0253186 A1	10/2012	Simpson et al.			
2012/0253192 A1	10/2012	Cressman			
2012/0253276 A1	10/2012	Govari et al.			
2012/0257210 A1	10/2012	Whitney et al.			
2012/0262720 A1	10/2012	Brown et al.			
2012/0265077 A1	10/2012	Gille et al.			
2012/0265268 A1	10/2012	Blum et al.			
2012/0265296 A1	10/2012	McNamara et al.			
2012/0271170 A1	10/2012	Emelianov et al.			
2012/0271175 A1	10/2012	Moore et al.			
2012/0271339 A1	10/2012	O'Beirne et al.			
2012/0274338 A1	11/2012	Baks et al.			
2012/0276390 A1	11/2012	Ji et al.			
2012/0277722 A1	11/2012	Gerber et al.			
2012/0279764 A1	11/2012	Jiang et al.			
2012/0283758 A1	11/2012	Miller et al.			
2012/0289987 A1	11/2012	Wilson et al.			
2012/0299439 A1	11/2012	Huang			
2012/0310081 A1	12/2012	Adler et al.			
2012/0310332 A1	12/2012	Murray et al.			
2012/0319535 A1	12/2012	Dausch			
2012/0323075 A1	12/2012	Younge et al.			
2012/0323127 A1	12/2012	Boyden et al.			
2012/0330141 A1	12/2012	Brown et al.			
2013/0015975 A1	1/2013	Huennekens et al.			
2013/0023762 A1	1/2013	Huennekens et al.			
2013/0023763 A1	1/2013	Huennekens et al.			
2013/0026655 A1	1/2013	Lee et al.			
2013/0030295 A1	1/2013	Huennekens et al.			
2013/0030303 A1	1/2013	Ahmed et al.			
2013/0030410 A1	1/2013	Drasler et al.			
2013/0053949 A1	2/2013	Pintor et al.			
2013/0109958 A1	5/2013	Baumgart et al.			
2013/0109959 A1	5/2013	Baumgart et al.			
2013/0137980 A1	5/2013	Waters et al.			
2013/0150716 A1	6/2013	Stigall et al.			
2013/0158594 A1	6/2013	Carrison et al.			
2013/0218201 A1	8/2013	Obermiller et al.			
2013/0218267 A1	8/2013	Braido et al.			
2013/0223789 A1	8/2013	Lee et al.			
2013/0223798 A1	8/2013	Jenner et al.			
2013/0296704 A1	11/2013	Magnin et al.			
2013/0303907 A1	11/2013	Corl			
2013/0303920 A1	11/2013	Corl			
2013/0310698 A1	11/2013	Judell et al.			
2013/0331820 A1	12/2013	Itou et al.			
2013/0338766 A1	12/2013	Hastings et al.			
2013/0339958 A1	12/2013	Droste et al.			
2014/0039294 A1	2/2014	Jiang			
2014/0180067 A1	6/2014	Stigall et al.			
2014/0180128 A1	6/2014	Corl			
2014/0200438 A1	7/2014	Millett et al.			

..... A61B 5/00

..... G01S 15/89

..... A61B 8/12

(56) **References Cited**

FOREIGN PATENT DOCUMENTS

WO	2009/121067	A1	10/2009
WO	2009/137704	A1	11/2009
WO	2011/06886	A2	1/2011
WO	2011/038048	A1	3/2011
WO	2011/081688	A1	7/2011
WO	2012/003369	A2	1/2012
WO	2012/061935	A1	5/2012
WO	2012/071388	A2	5/2012
WO	2012/087818	A1	6/2012
WO	2012/098194	A1	7/2012
WO	2012/109676	A1	8/2012
WO	2012/130289	A1	10/2012
WO	2012/154767	A2	11/2012
WO	2012/155040	A1	11/2012
WO	2013/033414	A1	3/2013
WO	2013/033415	A2	3/2013
WO	2013/033418	A1	3/2013
WO	2013/033489	A1	3/2013
WO	2013/033490	A1	3/2013
WO	2013/033592	A1	3/2013
WO	2013/126390	A1	8/2013
WO	2014/109879	A1	7/2014

OTHER PUBLICATIONS

Herz et al., "Micromotor endoscope catheter for in vivo, ultrahigh resolution optical coherence tomography", *Optics Letters*, Oct. 2004.*

Yaqoob et al., "Methods and application areas of endoscopic optical coherence tomography", *J. Biomedical Optics*, Nov./Dec. 2006.*
U.S. Appl. No. 60/949,472, Kemp et al., filed Jul. 12, 2007.

U.S. Appl. No. 60/949,511, Dick et al., filed Jul. 12, 2007.
Atlantis (TM) SR Pro Coronary Imaging Catheter 40 MHz Directions for Use, REF Catalog No. 38942 (published 2006), Boston Scientific Corporation, One Boston Scientific Place, Natick, MA 01760-1537 USA.

Davies et al. Plaque fissuring—the cause of acute myocardial infarction, sudden ischaemic death, and crescendo angina. *British Heart Journal* (1985) 53: 363-373.

Davies et al. Risk of thrombosis in human atherosclerotic plaques: role of extracellular lipid, macrophage, and smooth muscle cell content. *British Heart Journal* (1993) 69:377-381.

Jang et al. Visualization of Coronary Atherosclerotic Plaques in Patients Using Optical Coherence Tomography: Comparison With Intravascular Ultrasound. *Journal of the American College of Cardiology* (2002) 39:604-609.

Little et al. The underlying coronary lesion in myocardial infarction: implications for coronary angiography. *Clinical Cardiology* (1991) 14(11):868-874. Abstract Only.

Nissen. Coronary Angiography and Intravascular Ultrasound. *American Journal of Cardiology* (2001) 87(suppl):15A-20A.

Princetel, Inc. R-series Fiber Optic Rotary Joint data sheet. www.princetel.com (accessed May 18, 2007) Princetel, Inc., 4 Princess Rd, Ste 209, Lawrenceville, NJ 08648.

Rabbani et al. Review: Strategies to achieve coronary arterial plaque stabilization. *Cardiovascular Research*. (1999) 41:402-417.

Yaqoob et al. Methods and application areas of endoscopic optical coherence tomography. *Journal of Biomedical Optics* (2006) 11(6): 063001-1-063001-19.

Strickland, 1970, Time-Domain Reflectometer Measurements, Tektronix, Beaverton, OR, (107 pages).

Tonino et al., 2009, Fractional flow reserve versus angiography for guiding percutaneous coronary intervention, *The New England Journal of Medicine*, 360:213-224.

Toregeani et al., 2008, Evaluation of hemodialysis arteriovenous fistula maturation by color-flow Doppler ultrasound, *J Vasc. Bras.* 7(3):203-213.

Trauneker et al., 1991, Bispecific single chain molecules (Janusins) target cytotoxic lymphocytes on HIV infected cells *EMBO J.*, 10:3655-3659.

Trolier-McKinstry et. al., 2004, Thin Film Piezoelectric for MEMS, *Journal of Electroceramics* 12:7-17.

Tuniz et al., 2010, Weaving the invisible thread: design of an optically invisible metamaterial fibre, *Optics Express* 18(17):18095-18105.

Urban et al., 2010, Design of a Pressure Sensor Based on Optical Bragg Grating Lateral Deformation, *Sensors (Basel)*, 10(12):11212-11225.

Vakoc et al., 2005, Phase-Resolved Optical Frequency Domain Imaging, *Optics Express* 13(14):5483-5493.

Wang et al., 2006, Multiple biomarkers for the prediction of first major cardiovascular events and death, *The New England Journal of Medicine*, 355(25):2631-2639.

Villard et al., 2002, Use of a blood substitute to determine instantaneous murine right ventricular thickening with optical coherence tomography, *Circulation*, 105:1843-1849.

Forstner & Moonen, 1999, A metric for covariance matrices, In *Technical Report of the Dpt of Geodesy and Geoinformatics*, Stuttgart University, 113-128.

Waterhouse et. al., 1993, Combinatorial infection and in vivo recombination: a strategy for making large phage antibody repertoires, *Nucleic Acids Res.*, 21:2265-2266.

Yasuno et al., 2004, Polarization-sensitive complex Fourier domain optical coherence tomography for Jones matrix imaging of biological samples, *Applied Physics Letters* 85(15):3023-3025.

Zhang et al., 2004, Full range polarization-sensitive Fourier domain optical coherence tomography, *Optics Express*, 12(24):6033-6039.

Fatemi et al., 1999, Vibro-acoustography: an imaging modality based on ultrasound-stimulated acoustic emission, *PNAS U.S.A.*, 96(12):6603-6608

Griffiths et al., 1993, Human anti-self antibodies with high specificity from phage display libraries, *The EMBO Journal*, 12:725-734.

Harrison et al., 2011, Guidewire Stiffness: What's in a name?, *J Endovasc Ther*, 18(6):797-801.

Rollins et al., 1998, In vivo video rate optical coherence tomography, *Optics Express* 3:219-229.

Zitova et al., 2003, Image registration methods: A survey. *Image and Vision Computing*, 21(11):977-1000.

Wegener, 2011, 3D Photonic Metamaterials and Invisibility Cloaks: The Method of Making, *MEMS 2011, Cancun, Mexico*, Jan. 23-27, 2011.

Jiang et al., 1992, Image registration of multimodality 3-D medical images by chamfer matching, *Proc. SPIE 1660, Biomedical Image Processing and Three-Dimensional Microscopy*, 356-66.

Bouma et al., 1999, Power-efficient nonreciprocal interferometer and linear-scanning fiber-optic catheter for optical coherence tomography, *Optics Letters*, 24(8):531-533.

Blanchet et al., 1993, Laser Ablation and the Production of Polymer Films, *Science*, 262(5134):719-721.

Li et al., 2000, Optical Coherence Tomography: Advanced Technology for the Endoscopic Imaging of Barrett's Esophagus, *Endoscopy*, 32(12):921-930.

Bruining et al., 2009, Intravascular Ultrasound Registration/Integration with Coronary Angiography, *Cardiology Clinics*, 27(3):531-540.

Clarke et al., 1995, Hypoxia and myocardial ischaemia during peripheral angioplasty, *Clinical Radiology*, 50(5):301-303.

David et al., 1974, Protein iodination with solid-state lactoperoxidase, *Biochemistry* 13:1014-1021.

Adler et al., 2007, Phase-Sensitive Optical Coherence Tomography at up to 370,000 Lines Per Second Using Buffered Fourier Domain Mode-Locked Lasers, *Optics Letters*, 32(6):626-628.

Elghanian et al., 1997, Selective colorimetric detection of polynucleotides based on the distance-dependent optical properties of gold nanoparticles, *Science*, 277(5329):1078-1080.

Gould et al., 1974, Physiologic basis for assessing critical coronary stenosis, *American Journal of Cardiology*, 33:87-94.

Tearney et al., 1997, In vivo Endoscopic Optical Biopsy with Optical Coherence Tomography, *Science*, 276:2037-2039.

Brummer, 1997, An euclidean distance measure between covariance matrices of speechceptra for text-independent speaker recognition, in *Proc. South African Symp. Communications and Signal Processing*: 167-172.

(56)

References Cited

OTHER PUBLICATIONS

- Jakobovits et al., 1993, Germ-line transmission and expression of a human-derived yeast artificial chromosome, *Nature* 362:255-258.
- Johnson et al., 1993, Human antibody engineering: Current Opinion in Structural Biology, 3:564-571.
- Jones et al., 1986, Replacing the complementarity-determining regions in a human antibody with those from a mouse, *Nature*, 321:522-525.
- Barnea et al., 1972, A class of algorithms for fast digital image registration, *IEEE Trans. Computers*, 21(2):179-186.
- Sihan et al., 2008, a novel approach to quantitative analysis of intraluminal optical coherence tomography imaging, *Comput. Cardiol.*:1089-1092.
- Karapatis et al., 1998, Direct rapid tooling: a review of current research, *Rapid Prototyping Journal*, 4(2):77-89.
- Kozbor et al., 1984, A human hybrid myeloma for production of human monoclonal antibodies, *J. Immunol.*, 133:3001-3005.
- Larin et al., 2004, Measurement of Refractive Index Variation of Physiological Analytes using Differential Phase OCT, *Proc of SPIE* 5325:31-34.
- Kruth et al., 2003, Lasers and materials in selective laser sintering, *Assembly Automation*, 23(4):357-371.
- Kumagai et al., 1994, Ablation of polymer films by a femtosecond high-peak-power Ti:sapphire laser at 798 nm, *Applied Physics Letters*, 65(14):1850-1852.
- Lefevre et al., 2001, Stenting of bifurcation lesions: a rational approach, *J. Interv. Cardiol.*, 14(6):573-585.
- Fischler et al., 1973, The representation and matching of pictorial structures, *IEEE Transactions on Computer* 22:67-92.
- Marks et al., 1992, By-Passing Immunization: Building High Affinity Human Antibodies by Chain Shuffling, *BioTechnol.*, 10:779-783.
- Maruno et al., 1991, Fluorine containing optical adhesives for optical communications systems, *J. Appl. Polymer. Sci.* 42:2141-2148.
- McCafferty et al., 1990, Phage antibodies: filamentous phage displaying antibody variable domains, *Nature* 348:552-554.
- Nitenberg et al., 1995, Coronary vascular reserve in humans: a critical review of methods of evaluation and of interpretation of the results, *Eur Heart J.* 16(Suppl 1):7-21.
- Oesterle et al., 1986, Angioplasty at coronary bifurcations: single-guide, two-wire technique, *Cathet Cardiovasc Diagn.*, 12:57-63.
- Oldenburg et al., 2003, Fast-Fourier-Domain Delay Line for In Vivo Optical Coherence Tomography with a Polygonal Scanner, *Applied Optics*, 42(22):4606-4611.
- Pain et al., 1981, Preparation of protein A-peroxidase mono conjugate using a heterobifunctional reagent, and its use in enzyme immunoassays, *J Immunol Methods*, 40:219-30.
- Persson et al., 1985, Acoustic impedance matching of medical ultrasound transducers, *Ultrasonics*, 23(2):83-89.
- Kersey et al., 1991, Polarization insensitive fiber optic Michelson interferometer, *Electron. Lett.* 27:518-520.
- Mindlin et al., 1936, A force at a point of a semi-infinite solid, *Physics*, 7:195-202.
- Riechmann et al., 1988, Reshaping human antibodies for therapy, *Nature*, 332:323-327.
- Rivers et al., 1992, Correction of steal syndrome secondary to hemodialysis access fistulas: a simplified quantitative technique, *Surgery*, 112(3):593-7.
- Tanimoto et al., 2008, A novel approach for quantitative analysis of intracoronary optical coherence tomography: high inter-observer agreement with computer-assisted contour detection, *Cathet Cardiovascular Intervent.*, 72(2):228-235.
- Munson et al., 1980, Ligand: a versatile computerized approach for characterization of ligand-binding systems, *Analytical Biochemistry*, 107:220-239.
- Smith et al., 1989, Absolute displacement measurements using modulation of the spectrum of white light in a Michelson interferometer, *Applied Optics*, 28(16):3339-3342.
- Milstein et al., 1983, Hybrid hybridomas and their use in immunohistochemistry, *Nature* 305:537-540.
- Soller, 2003, Polarization diverse optical frequency domain interferometry: All coupler implementation, Bragg Grating, Photo-sensitivity, and Poling in Glass Waveguides Conference MIB4:30-32.
- Stenqvist et al., 1983, Stiffness of central venous catheters, *Acta Anaesthesiol Scand.*, 2:153-157.
- Sutcliffe et al., 1986, Dynamics of UV laser ablation of organic polymer surfaces, *Journal of Applied Physics*, 60(9):3315-3322.
- Vakhtin et al., 2003, Common-path interferometer for frequency-domain optical coherence tomography, *Applied Optics*, 42(34):6953-6958.
- Verhoeven et al., 1988, Reshaping human antibodies: grafting an antilysozyme activity, *Science*, 239:1534-1536.
- Wang et al., 2009, Robust Guidewire Tracking in Fluoroscopy, *IEEE Conference on Computer Vision and Pattern Recognition—CVPR 2009*:691-698.
- Wang et al., 2002, Optimizing the Beam Pattern of a Forward-Viewing Ring-Annular Ultrasound Array for Intravascular Imaging, *Transactions on Ultrasonics, Ferroelectrics, and Frequency Control*, 49(12).
- Felzenszwalb et al., 2005, Pictorial Structures for Object Recognition, *International Journal of Computer Vision*, 61(1):55-79.
- Juviler et al., 2008, Anorectal sepsis and fistula-in-ano, *Surgical Technology International*, 17:139-149.
- Kirkman, 1991, Technique for flow reduction in dialysis access fistulas, *Surg Gyn Obstet*, 172(3):231-3.
- Wyawahare et al., 2009, Image registration techniques: an overview, *International Journal of Signal Processing, Image Processing and Pattern Recognition*, 2(3):11-28.
- Suzuki, 2013, A novel guidewire approach for handling acute-angle bifurcations, *J Inv Cardiol* 25(1):48-54.
- West et al., 1991, Arterial insufficiency in hemodialysis access procedures: correction by banding technique, *Transpl Proc* 23(2):1838-40.
- Notice of Reason(s) for Refusal dated Apr. 30, 2013, for Japanese Patent Application No. 2011-508677 for Optical Imaging Catheter for Aberration Balancing to Volcano Corporation, which application is a Japanese national stage entry of PCT/US2009/043181 with international filing date May 7, 2009, of the same title, published on Nov. 12, 2009, as WO 2009/137704, and accompanying English translation of Notice of Reason(s) for Refusal and machine translations of JP11-56786 and JP2004-290548 (56 pages).
- International Search Report and Written Opinion dated Jul. 30, 2014, for International Patent Application No. PCT/US14/21659, filed Mar. 7, 2014 (15 pages).
- Amini et al., 1990, Using dynamic programming for solving variational problems in vision, *IEEE Transactions on Pattern Analysis and Machine Intelligence*, 12(9):855-867.
- Abdi et al., 2010, Principal component analysis, *Wiley Interdisciplinary Reviews: Computational Statistics* 2:433-459.
- Agresti, 1996, Models for Matched Pairs, Chapter 8, *An Introduction to Categorical Data Analysis*, Wiley-Interscience A John Wiley & Sons, Inc., Publication, Hoboken, New Jersey.
- Akashah et al., 2004, Development of piezoelectric micromachined ultrasonic transducers, *Sensors and Actuators A Physical*, 111:275-287.
- Bain, 2011, Privacy protection and face recognition, Chapter 3, *Handbook of Face Recognition*, Stan et al., Springer-Verlag.
- Breiman, 2001, Random forests, *Machine Learning* 45:5-32.
- Burr et al., 2005, Searching for the Center of an Ellipse in Proceedings of the 17th Canadian Conference on Computational Geometry:260-263.
- Fookes et al., 2002, Rigid and non-rigid image registration and its association with mutual information: A review, *Technical Report ISBN:1 86435 569 7, RCCVA, QUT.*
- Cavalli et al., 2010, Nanosponge formulations as oxygen delivery systems, *International Journal of Pharmaceutics* 402:254-257.
- Collins, 1993, Coronary flow reserve, *British Heart Journal* 69:279-281.

(56) **References Cited**

OTHER PUBLICATIONS

- Communication Mechanisms for Distributed Real-Time Applications, NI Developer Zone, <http://zone.ni.com/devzone/cda/tut/p/id/3105>, accessed Jul. 23, 2007.
- Cook, 2007, Use and misuse of receiver operating characteristic curve in risk prediction, *Circulation* 115(7):928-35.
- D'Agostino et al., 2001, Validation of the Framingham coronary heart disease prediction score: results of a multiple ethnic group investigation, *JAMA* 286:180-187.
- Kemp et al., 2005, Depth Resolved Optic Axis Orientation in Multiple Layered Anisotropic Tissues Measured with Enhanced Polarization Sensitive Optical Coherence Tomography, *Optics Express* 13(12):4507-4518.
- Deterministic Data Streaming in Distributed Data Acquisition Systems, NI Developer Zone, "What is Developer Zone?", <http://zone.ni.com/devzone/cda/tut/p/id/3105>, accessed Jul. 23, 2007.
- Eigenwillig, 2008, K-Space Linear Fourier Domain Mode Locked Laser and Applications for Optical Coherence Tomography, *Optics Express* 16(12):8916-8937.
- Ergun et al., 2003, Capacitive Micromachined Ultrasonic Transducers: Theory and Technology, *Journal of Aerospace Engineering*, 16(2):76-84.
- Fleming et al., 2010, Real-time monitoring of cardiac radio-frequency ablation lesion formation using an optical coherence tomography forward-imaging catheter, *Journal of Biomedical Optics* 15 (3):030516-1 (3 pages).
- Evans et al., 2006, Optical coherence tomography to identify intramucosa carcinoma and high-grade dysplasia in Barrett's esophagus, *Clin Gast Hepat* 4(1):38-43.
- Grund et al., 2010, Analysis of biomarker data: logs, odds, ratios and ROC curves, *Curr Opin HIV AIDS* 5(6):473-479.
- Gotzinger et al., 2005, High speed spectral domain polarization sensitive optical coherence tomography of the human retina, *Optics Express* 13(25):10217-10229.
- Griffiths et al., 1994, Isolation of high affinity human antibodies directly from large synthetic repertoires, *The EMBO Journal*, 13(14):3245-3260.
- Huber et al., 2005, Amplified, Frequency Swept Lasers for Frequency Domain Reflectometry and OCT Imaging: Design and Scaling Principles, *Optics Express* 13(9):3513-3528.
- Huber et al., 2006, Fourier Domain Mode Locking (FDML): A New Laser Operating Regime and Applications for Optical Coherence Tomography, *Optics Express* 14(8):3225-3237.
- Bonnema, 2008, Imaging Tissue Engineered Blood Vessel Mimics with Optical Tomography, College of Optical Sciences dissertation, University of Arizona (252 pages).
- International Search Report and Written Opinion dated Nov. 2, 2012, for International Patent Application No. PCT/US12/53168, filed Aug. 30, 2013 (8 pages).
- International Search Report and Written Opinion dated Mar. 11, 2014, for International Patent Application No. PCT/US13/75675, filed Dec. 17, 2013 (7 pages).
- International Search Report and Written Opinion dated Mar. 19, 2014, for International Patent Application No. PCT/US13/075353, filed Dec. 16, 2013 (8 pages).
- International Search Report and Written Opinion dated Apr. 14, 2014, for International Patent Application No. PCT/US2013/076148, filed Dec. 18, 2013 (8 pages).
- International Search Report and Written Opinion dated Apr. 21, 2014, for International Patent Application No. PCT/US2013/076015, filed Dec. 18, 2013 (7 pages).
- International Search Report and Written Opinion dated Apr. 23, 2014, for International Patent Application No. PCT/US2013/075328, filed Dec. 16, 2013 (8 pages).
- International Search Report and Written Opinion dated Apr. 29, 2014, for International Patent Application No. PCT/US13/76093, filed Dec. 18, 2013 (6 pages).
- International Search Report and Written Opinion dated Apr. 9, 2014, for International Patent Application No. PCT/US13/75089, filed Dec. 13, 2013 (7 pages).
- International Search Report and Written Opinion dated Feb. 21, 2014, for International Patent Application No. PCT/US13/76053, filed Dec. 18, 2013 (9 pages).
- International Search Report and Written Opinion dated Feb. 21, 2014, for International Patent Application No. PCT/US2013/076965, filed Dec. 20, 2013 (6 pages).
- International Search Report and Written Opinion dated Feb. 27, 2014, for International Patent Application No. PCT/US13/75416, filed Dec. 16, 2013 (7 pages).
- International Search Report and Written Opinion dated Feb. 28, 2014, for International Patent Application No. PCT/US13/75653, filed Dec. 17, 2013 (7 pages).
- International Search Report and Written Opinion dated Feb. 28, 2014, for International Patent Application No. PCT/US13/75990, filed Dec. 18, 2013 (7 pages).
- International Search Report and Written Opinion dated Mar. 10, 2014, for International Patent Application No. PCT/US2013/076212, filed Dec. 18, 2013 (8 pages).
- International Search Report and Written Opinion dated Mar. 11, 2014, for International Patent Application No. PCT/US13/76173, filed Dec. 16, 2013 (9 pages).
- International Search Report and Written Opinion dated Mar. 11, 2014, for International Patent Application No. PCT/US13/76449, filed Dec. 19, 2013 (9 pages).
- International Search Report and Written Opinion dated Mar. 18, 2014, for International Patent Application No. PCT/US2013/076502, filed Dec. 19, 2013 (7 pages).
- International Search Report and Written Opinion dated Mar. 18, 2014, for International Patent Application No. PCT/US2013/076788, filed Dec. 20, 2013 (7 pages).
- International Search Report and Written Opinion dated Mar. 19, 2014, for International Patent Application No. PCT/US13/75349, filed Dec. 16, 2013 (10 pages).
- International Search Report and Written Opinion dated Mar. 19, 2014, for International Patent Application No. PCT/US2013/076587, filed Dec. 19, 2013 (10 pages).
- International Search Report and Written Opinion dated Mar. 19, 2014, for International Patent Application No. PCT/US2013/076909, filed Dec. 20, 2013 (7 pages).
- International Search Report and Written Opinion dated Mar. 7, 2014, for International Patent Application No. PCT/US2013/076304, filed Dec. 18, 2013 (9 pages).
- International Search Report and Written Opinion dated Mar. 7, 2014, for International Patent Application No. PCT/US2013/076480, filed Dec. 19, 2013 (8 pages).
- International Search Report and Written Opinion dated Mar. 7, 2014, for International Patent Application No. PCT/US2013/076512, filed Dec. 19, 2013 (8 pages).
- International Search Report and Written Opinion dated Mar. 7, 2014, for International Patent Application No. PCT/US2013/076531, filed Dec. 19, 2013 (10 pages).
- International Search Report and Written Opinion dated Jan. 16, 2009, for International Patent Application No. PCT/US08/78963 filed on Oct. 6, 2008 (7 Pages).
- Wang et al., 2011, In vivo intracardiac optical coherence tomography imaging through percutaneous access: toward image-guided radio-frequency ablation, *J. Biomed. Opt.* 0001 16(11):110505-1 (3 pages).
- Canny, 1986, A computational approach to edge detection, *IEEE Trans. Pattern Anal. Mach. Intell.* 8:679-698.
- Maintz et al., 1998, An Overview of Medical Image Registration Methods, Technical Report UU-CS, (22 pages).
- Jakobovits et al., 1993, Analysis of homozygous mutant chimeric mice: deletion of the immunoglobulin heavy-chain joining region blocks B-cell development and antibody production, *PNAS USA* 90:2551-2555.
- Othonos, 1997, Fiber Bragg gratings, *Review of Scientific Instruments* 68(12):4309-4341.
- Owens et al., 2007, A Survey of General-Purpose Computation on Graphics Hardware, *Computer Graphics Forum* 26(1):80-113.
- Karp et al., 2009, The benefit of time-of-flight in PET imaging, *J Nucl Med* 49:462-470.

(56)

References Cited

OTHER PUBLICATIONS

- Kelly et al., 2005, Detection of Vascular Adhesion Molecule-1 Expression Using a Novel Multimodal Nanoparticle, *Circulation Research* 96:327-336.
- Kheir et al., 2012, Oxygen Gas-Filled Microparticles Provide Intravenous Oxygen Delivery, *Science Translational Medicine* 4(140):140ra88 (10 pages).
- Khuri-Yakub et al., 2011, Capacitive micromachined ultrasonic transducers for medical imaging and therapy, *J Micromech Microeng.* 21(5):054004-054014.
- Kohler et al., 1975, Continuous cultures of fused cells secreting antibody of predefined specificity, *Nature*, 256:495-7.
- Koo et al., 2011, Diagnosis of Ischemia Causing Coronary Stenoses by Noninvasive Fractional Flow Reserve Computed From Coronary Computed Tomographic Angiograms, *J Am Coll Cardiol* 58(19):1989-1997.
- Larin et al., 2002, Noninvasive Blood Glucose Monitoring with Optical Coherence Tomography: a pilot study in human subjects, *Diabetes Care*, 25(12):2263-7.
- Brown, 1992, A survey of image registration techniques, *ACM Computing Surveys* 24(4):325-376.
- Loo, 2004, Nanoshell Enabled Photonics-Based Imaging and Therapy of Cancer, *Technology in Cancer Research & Treatment* 3(1):33-40.
- Turk et al., 1991, Eigenfaces for Recognition, *Journal of Cognitive Neuroscience* 3(1):71-86.
- Choma et al., 2003, Sensitivity Advantage of Swept Source and Fourier Domain Optical Coherence Tomography, *Optics Express* 11(18):2183-2189.
- Mamas et al., 2010, Resting Pd/Pa measured with intracoronary pressure wire strongly predicts fractional flow reserve, *Journal of Invasive Cardiology* 22(6):260-265.
- Marks et al., 1991, By-passing Immunization Human Antibodies from V-gene Libraries Displayed on Phage, *J. Mol. Biol.* 222:581-597.
- Mendieta et al., 1996, Complementary sequence correlations with applications to reflectometry studies, *Instrumentation and Development* 3(6):37-46.
- Mickley, 2008, Steal Syndrome—strategies to preserve vascular access and extremity, *Nephrol Dial Transplant* 23:19-24.
- Goel et al., 2006, Minimally Invasive Limited Ligation Endoluminal-assisted Revision (MILLER) for treatment of dialysis access-associated steal syndrome, *Kidney Int* 70(4):765-70.
- Miller et al., 2010, The MILLER banding procedure is an effective method for treating dialysis-associated steal syndrome, *Kidney International* 77:359-366.
- Morrison et al., 1984, Chimeric human antibody molecules: mouse antigen-binding domains with human constant region domains, *PNAS* 81:6851-6855.
- Ferring et al., 2008, Vasculature ultrasound for the pre-operative evaluation prior to arteriovenous fistula formation for haemodialysis: review of the evidence, *Nephrol. Dial. Transplant.* 23(6):1809-1815.
- Nygren, 1982, Conjugation of horseradish peroxidase to Fab fragments with different homobifunctional and heterobifunctional cross-linking reagents. A comparative study, *J. Histochem. and Cytochem.* 30:407-12.
- Tuzel et al., 2006, Region Covariance: A Fast Descriptor for Detection and Classification, *European Conference on Computer Vision (ECCV)*.
- Okuno et al., 2003, Recent Advances in Optical Switches Using Silica-based PLC Technology, *NTT Technical Review* 1(7):20-30.
- Oldenburg et al., 1998, Nanoengineering of Optical Resonances, *Chemical Physics Letters* 288:243-247.
- Bail et al., 1996, Optical coherence tomography with the “Spectral Radar”—Fast optical analysis in volume scatterers by short coherence interferometry, *Optics Letters* 21(14):1087-1089.
- Park et al., 2005, Real-time fiber-based multi-functional spectral-domain optical coherence tomography at 1.3 μm , *Optics Express* 13(11):3931-3944.
- Pasquesi et al., 2006, In vivo detection of exercise induced ultrastructural changes in genetically-altered murine skeletal muscle using polarization-sensitive optical coherence tomography, *Optics Express* 14(4):1547-1556.
- Pepe et al., 2004, Limitations of the odds ratio in gauging the performance of a diagnostic, prognostic, or screening marker, *American Journal of Epidemiology* 159(9):882-890.
- Placht et al., 2012, Fast time-of-flight camera based surface registration for radiotherapy patient positioning, *Medical Physics* 39(1):4-17.
- Radvany et al., 2008, Plaque Excision in Management of Lower Extremity Peripheral Arterial Disease with the SilverHawk Atherectomy Catheter, *Seminars in Interventional Radiology*, 25(1):11-19.
- Reddy et al., 1996, An FFT-Based Technique for Translation, Rotation, and Scale-Invariant Image Registration, *IEEE Transaction on Image Processing* 5(8):1266-1271.
- Robbin et al., 2002, Hemodialysis Arteriovenous Fistula Maturity: US Evaluation, *Radiology* 225:59-64.
- Sarunic et al., 2005, Instantaneous Complex Conjugate Resolved Spectral Domain and Swept-Source OCT Using 3x3 Fiber Couplers, *Optics Express* 13(3):957-967.
- Satiani et al., 2009, Predicted Shortage of Vascular Surgeons in the United States, *J. Vascular Surgery* 50:946-952.
- Schneider et al., 2006, T-banding: A technique for flow reduction of a hyper-functioning arteriovenous fistula, *J Vase Surg.* 43(2):402-405.
- Sen et al., 2012, Development and validation of a new adenosine-independent index of stenosis severity from coronary wave-intensity analysis, *Journal of the American College of Cardiology* 59(15):1392-1402.
- Setta et al., 2005, Soft versus firm embryo transfer catheters for assisted reproduction: a systematic review and meta-analysis, *Human Reproduction*, 20(11):3114-3121.
- Seward et al., 1996, Ultrasound Cardioscopy: Embarking on New Journey, *Mayo Clinic Proceedings* 71(7):629-635.
- Shen et al., 2006, Eigengene-based linear discriminant model for tumor classification using gene expression microarray data, *Bioinformatics* 22(21):2635-2642.
- Siwy et al., 2003, Electro-responsive asymmetric nanopores in polyimide with stable ion-current signal, *Applied Physics A: Materials Science & Processing* 76:781-785.
- Smith, 1997, *The Scientist and Engineer’s Guide to Digital Signal Processing*, California Technical Publishing, San Diego, CA:432-436.
- Nezam, 2008, High Speed Polygon-Scanner-Based Wavelength-Swept Laser Source in the Telescope-Less Configurations with Application in Optical Coherence Tomography, *Optics Letters* 33(15):1741-1743.
- Song et al., 2012, Active tremor cancellation by a “Smart” handheld vitreoretinal microsurgical tool using swept source optical coherence tomography, *Optics Express*, 20(21):23414-23421.
- Strobl et al., 2009, An Introduction to Recursive Partitioning: Rationale, Application and Characteristics of Classification and Regression Trees, Bagging and Random Forests, *Psychol Methods.*, 14(4):323-348.

* cited by examiner

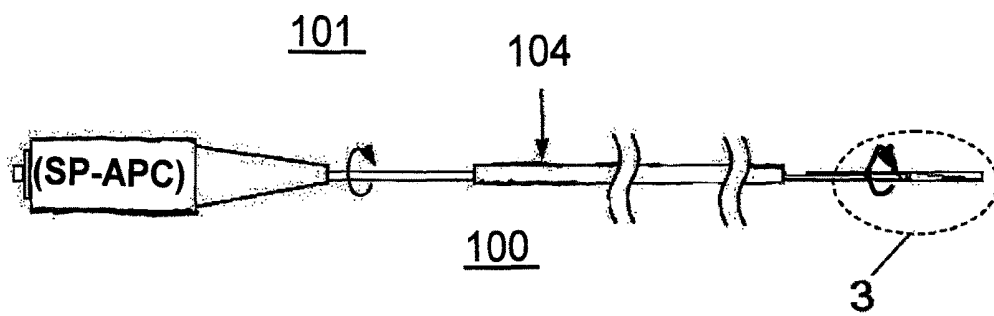

FIG. 1

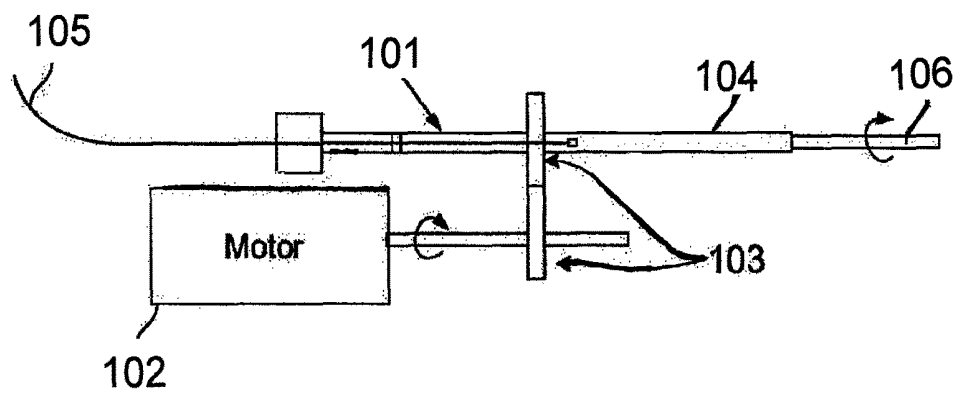

FIG. 2

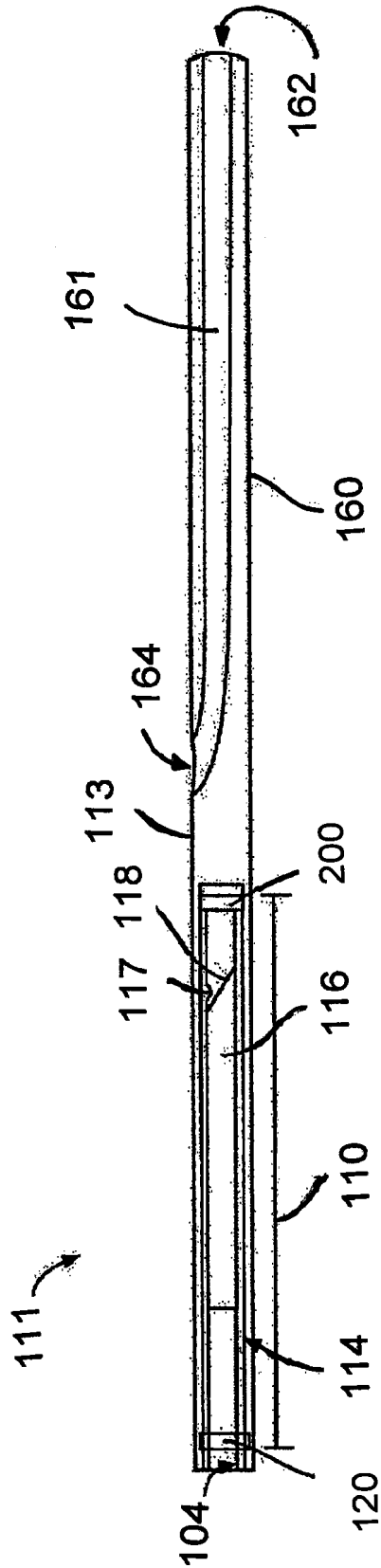

FIG. 3

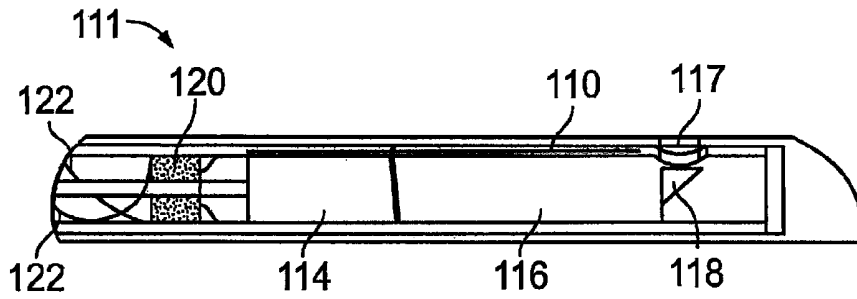

FIG. 4

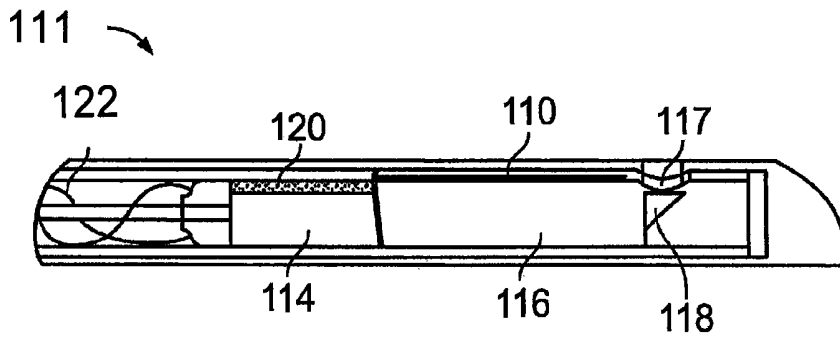

FIG. 5

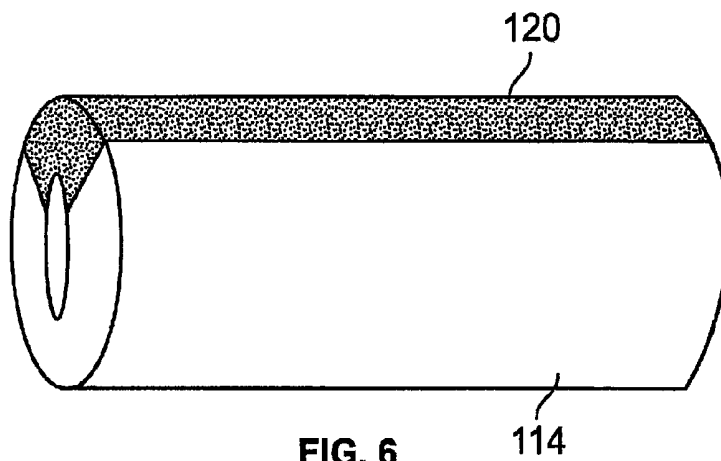

FIG. 6

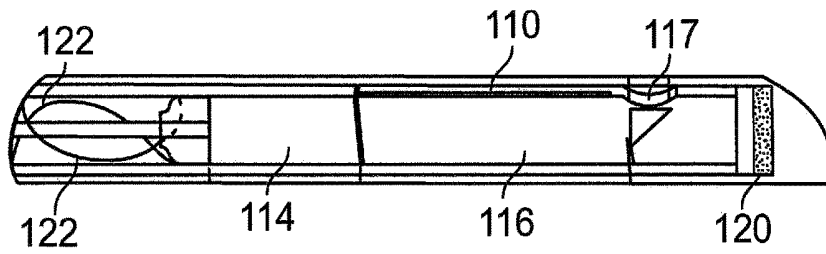

FIG. 7

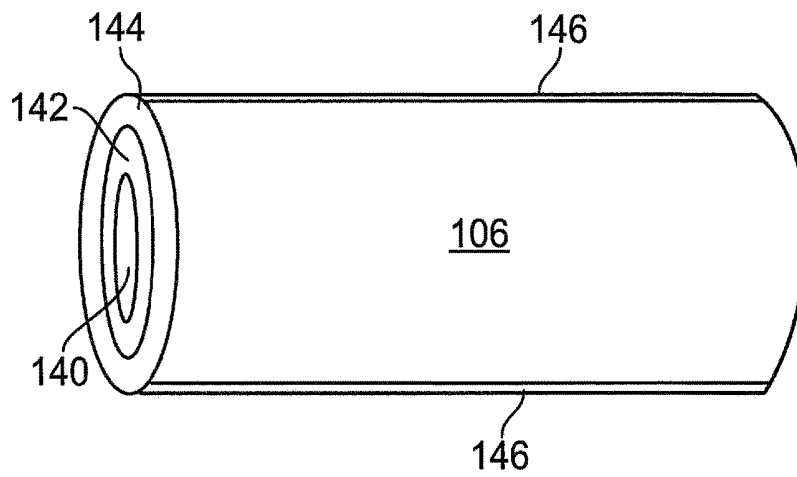

FIG. 8

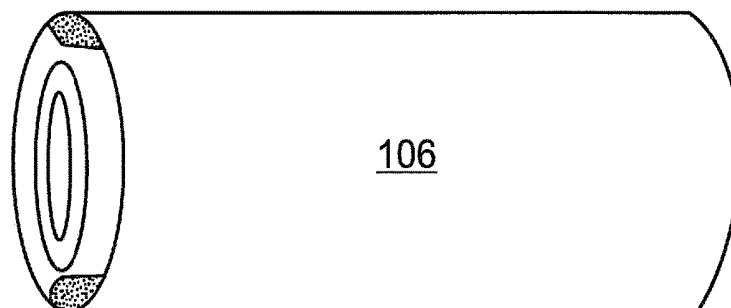

FIG. 9

OCT-IVUS CATHETER FOR CONCURRENT LUMINAL IMAGING

CROSS-REFERENCE TO RELATED INVENTIONS

This application claims priority pursuant to 35 U.S.C. § 119(e) from U.S. Provisional Application Ser. Nos. 60/949,472 and 60/949,511, both filed Jul. 12, 2007 and incorporated by reference herein.

BACKGROUND OF THE INVENTION

The present invention relates generally to an apparatus for in vivo imaging. More particularly, the present invention relates to a catheter that incorporates an Optical Coherence Tomography (OCT) system and an Intravascular Ultrasound (IVUS) system for concurrent imaging of luminal systems, such as imaging the vasculature system, including, without limitation, cardiac vasculature, peripheral vasculature and neural vasculature.

Myocardial infarction or heart attack remains the leading cause of death in society. Until recently, many investigators believed that the primary mechanism for myocardial infarction was coronary arteries critically blocked with atherosclerotic plaque that subsequently progressed to total occlusion. Recent evidence from many investigational studies, however, clearly indicates that most infarctions are caused by sudden rupture of non-critically stenosed coronary arteries resulting from sudden plaque rupture. For example, Little et al. (Little, W C, Downes, T R, Applegate, R J. The underlying coronary lesion in myocardial infarction: implications for coronary angiography. *Clin Cardiol* 1991, 14: 868-874, incorporated by reference herein) observed that approximately 70% of patients suffering from an acute plaque rupture were initiated on plaques that were less than 50% occluded as revealed by previous coronary angiography. This and similar observations have been confirmed by other investigators (Nissen, S. Coronary angiography and intravascular ultrasound. *Am J Cardiol* 2001, 87 (suppl): 15A-20 A, incorporated by reference herein).

The development of technologies to identify these unstable plaques holds the potential to decrease substantially the incidence of acute coronary syndromes that often lead to premature death. Unfortunately, no methods are currently available to the cardiologist that may be applied to specify which coronary plaques are vulnerable and thus prone to rupture. Although treadmill testing has been used for decades to identify patients at greater cardiovascular risk, this approach does not have the specificity to differentiate between stable and vulnerable plaques that are prone to rupture and frequently result in myocardial infarction. Inasmuch as a great deal of information exists regarding the pathology of unstable plaques (determined at autopsy), technologies based upon identifying the well-described pathologic appearance of the vulnerable plaque offers a promising long term strategy to solve this problem.

The unstable plaque was first identified and characterized by pathologists in the early 1980's. Davis noted that with the reconstruction of serial histological sections in patients with acute myocardial infarctions associated with death, a rupture or fissuring of athermanous plaque was evident (Davis M J, Thomas A C. Plaque fissuring: the cause of acute myocardial infarction, sudden death, and crescendo angina. *Br Heart J* 1985; 53: 3 63-37 3, incorporated by reference herein). Ulcerated plaques were further characterized as having a thin fibrous cap, increased macrophages with decreased

smooth muscle cells and an increased lipid core when compared to non-ulcerated atherosclerotic plaques in human aortas (Davis M J, Richardson E D, Woolf N, Katz O R, Mann J. Risk of thrombosis in human atherosclerotic plaques: role of extracellular lipid, macrophage, and smooth muscle cell content, incorporated by reference herein). Furthermore, no correlation in size of lipid pool and percent stenosis was observed when imaging by coronary angiography. In fact, most cardiologists agree that unstable plaques progress to more stenotic yet stable plaques through progression via rupture with the formation of a mural thrombus and plaque remodeling, but without complete luminal occlusion (Topol E J, Rabbaic R. Strategies to achieve coronary arterial plaque stabilization. *Cardiovasc Res* 1999; 41: 402-417, incorporated by reference herein). Neovascularization with intra-plaque hemorrhage may also play a role in this progression from small lesions, i.e., those less than about 50% occluded, to larger significant plaques. Yet, if the unique features of unstable plaque could be recognized by the cardiologist and then stabilized, a dramatic decrease may be realized in both acute myocardial infarction and unstable angina syndromes, and in the sudden progression of coronary artery disease.

The present invention uses depth-resolved light reflection or Optical Coherence Tomography to identify the pathological features that have been identified in the vulnerable plaque. In OCT, light from a broad band light source or tunable laser source is split by an optical fiber splitter with one fiber directing light to the vessel wall and the other fiber directing light to a reference mirror. The distal end of the optical fiber is interfaced with a catheter for interrogation of the coronary artery during a heart catheterization procedure. The reflected light from the plaque is recombined with the signal from the reference mirror forming interference fringes (measured by a photovoltaic detector) allowing precise depth-resolved imaging of the plaque on a micron scale.

OCT uses a superluminescent diode source or tunable laser source emitting a 400-2000 nm wavelength, with a 50-250 nm band width (distribution of wave length) to make in situ tomographic images with axial resolution of 2-20 μ m and tissue penetration of 2-3 mm. OCT has the potential to image tissues at the level of a single cell. In fact, the inventors have recently utilized broader bandwidth optical sources so that axial resolution is improved to 4 μ m or less. With such resolution, OCT can be applied to visualize intimal caps, their thickness, and details of structure including fissures, the size and extent of the underlying lipid pool and the presence of inflammatory cells. Moreover, near infrared light sources used in OCT instrumentation can penetrate into heavily calcified tissue regions characteristic of advanced coronary artery disease. With cellular resolution, application of OCT may be used to identify other details of the vulnerable plaque such as infiltration of monocytes and macrophages. In short, application of OCT can provide detailed images of a pathologic specimen without cutting or disturbing the tissue.

An OCT catheter to image coronary plaques has been built and is currently being tested by investigators. (Jang I K, Bouma B E, Hang O H, et al. Visualization of coronary atherosclerotic plaques in patients using optical coherence tomography: comparison with intravascular ultrasound. *JACC* 2002; 3 9: 604-609, incorporated by reference herein). The prototype catheter consists of a single light source and is able to image over a 360 degree arc of a coronary arterial lumen by rotating a shaft that spins the optical fiber. Because the rotating shaft is housed outside of the body, the spinning rod in the catheter must rotate with uniform angular velocity

so that the light can be focused for equal intervals of time on each angular segment of the coronary artery.

While OCT imaging provides high resolution (2-20 μm) tomographic visualization of coronary arteries, OCT, however, lacks penetration with a maximum penetration depth of only 2-3 mm into the tissue. The present invention overcomes this disadvantage by incorporating an ultrasound transducer suitable for performing intravascular ultrasound ("IVUS") into an OCT catheter to form an OCT-IVUS catheter. The present invention uses IVUS imaging to identify the pathological features that have been identified in the vulnerable plaque. A particularly valuable tool, IVUS technology uses high frequency sound waves to detect blood vessel blockages and other problems such as aneurysms.

Ultrasound imaging systems can be equipped with a 38 mm aperture, broadband (5-10 MHz) linear array transducer. Cells can be imaged in color power Doppler, power Doppler, M-mode and B-scan modes. B-scan sonogram images, also called the grayscale mode, are the typical ultrasound method to monitor or examine the human body using backscattering of acoustic waves. M-mode ultrasound employs a sequence of scans at a fixed ultrasound beam over a given time period. M-mode is used for visualizing rapidly moving subjects, such as heart valves. Compared to conventional B-scan images, Doppler ultrasound is used to assess changes in the frequency of reflected acoustic waves. Color power Doppler converts reflected acoustic waves that are Doppler shifted into colors that overlay the conventional B-scan images and can indicate the speed and direction of moving objects. Power Doppler ultrasound is most commonly used to evaluate moving objects and has higher sensitivity than the color power Doppler mode. The gain of the color power and Doppler imaging mode can be manually adjusted to suppress the background noise. If the settings of the ultrasound instrumentation remain unchanged, objective comparisons of each can be made. Additional disclosure explaining how OCT and ultrasound imaging systems work and cooperate can be found in commonly assigned and co-pending U.S. patent application Ser. No. 11/550,771, filed Oct. 18, 2006 and published as U.S. Publication No. US 2008-0097194 on Apr. 24, 2008, which is incorporated herein by reference in its entirety.

IVUS is a widely available clinical tool for guiding percutaneous interventions and/or intraluminal imaging. While IVUS uses frequencies from 20 to 40 MHz and provides good depth penetration, it lacks sufficient resolution (~120 μm) to study thin-cap thrombus or atheroma lesions and other fine details with the vasculature. Conversely, while OCT provides high resolution (2-20 μm) tomographic visualization of coronary arteries, OCT, however, lacks penetration with a maximum penetration depth of only 2-3 mm. However, it has been found that OCT can image behind calcifications clearly while ultrasounds are intensely reflected. The current high resolution capabilities of OCT are well suited for imaging vulnerable plaques but poor depth penetration hamper full characterization of coronary lesions and plaque burden. Because IVUS penetrates deeper into the media and adventitia, combining OCT and IVUS modalities will enhance quantitative analysis of coronary arteries significantly.

SUMMARY OF THE INVENTION

The present invention relates to a catheter that incorporates an Optical Coherence Tomography (OCT) system and an Intravascular Ultrasound ("IVUS) system for concurrent imaging of luminal systems, such as imaging the vasculature

system, including, without limitation, cardiac vasculature, peripheral vasculature and neural vasculature. An OCT assembly and an IVUS transducer are positioned at the distal end of the catheter.

A combined OCT and IVUS catheter imaging system has been developed to provide cross-sectional structural images of blood vessels, including coronary arteries. A catheter assembly surrounding an OCT assembly and an IVUS transducer at the distal end of an imaging core is used to accomplish such imaging. The catheter assembly is positioned within a blood vessel at the site of interest (i.e., the location of a stenosis). The OCT assembly and IVUS transducer generate a series of pulses which are transmitted outward from the OCT assembly and the IVUS transducer as they are rotated. Echo pulses reflected from the surrounding tissues are received by the OCT assembly and the IVUS transducer and collected by a control apparatus coupled to the proximal end of the sheath. The collected data is then combined, transformed, and displayed as a cross-sectional image of the vessel and surrounding tissue.

The scope of the invention is indicated in the appended claims. It is intended that all changes or modifications within the meaning and range of equivalents are embraced by the claims.

The foregoing and other features and advantages of the invention are apparent from the following detailed description of exemplary embodiments, read in conjunction with the accompanying drawings. The detailed description and drawings are merely illustrative of the invention rather than limiting, the scope of the invention being defined by the appended claims and equivalents thereof.

BRIEF DESCRIPTION OF THE DRAWINGS

FIG. 1 is a diagrammatic side view of the present invention's OCT-IVUS system.

FIG. 2 is a side view of an actuation system for rotating the OCT-IVUS catheter in accordance with the present invention.

FIG. 3 is a side view of the distal end optics of the OCT assembly in accordance with the present invention taken from circle 3 in FIG. 1.

FIG. 4 is a side view of the distal end optics and ultrasound transducer of one embodiment of the invention.

FIG. 5 is a side view of the distal end optics and ultrasound transducer of another embodiment of the invention.

FIG. 6 is perspective view of a combined ferrule-ultrasound transducer in accordance with an embodiment of the present invention.

FIG. 7 is a side view of the distal end optics and ultrasound transducer of another embodiment of the invention.

FIG. 8 is a perspective view of one embodiment of an optical fiber in accordance with the present invention.

FIG. 9 is a perspective view of another embodiment of an optical fiber in accordance with the present invention.

DETAILED DESCRIPTION OF THE PREFERRED EMBODIMENTS

In the accompanying figures, like elements are identified by like reference numerals among the several preferred embodiments of the present invention.

In the present invention, a distal end assembly including an ultrasound transducer 120 and an optical coherence tomography ("OCT") assembly (as hereinafter described)

are positioned longitudinally adjacent or in close proximity to each other at or near a distal end of a catheter assembly **111**. Both the ultrasound transducer **120** and the OCT assembly are coupled to a rotary drive system (as hereinafter described) that rotates both the OCT assembly and the ultrasound transducer **120** about their longitudinal axis and within a catheter sheath.

The ultrasound transducer **120** may be a single-element crystal or probe that is mechanically scanned or rotated back and forth to cover a sector over a selected angular range. OCT and acoustic signals are then transmitted and echoes (or backscatter) from these OCT and acoustic signals are received. The ultrasound transducer **120** and the OCT assembly may be oriented to direct their respective energies such that the optical signal and the ultrasound signal scan the same or at least partially overlapping spatial areas. Alternatively, the optical signal and the ultrasound signal may be aligned by employing appropriate computer processing software to adjust for spatial discrepancies between the two signals and permit simultaneous display of at least partially coordinated optical images and the ultrasound images to the physician. The backscatter data can be used to identify the type of a scanned tissue. As the probe is swept through the sector, many OCT and acoustic lines are processed building up a sector-shaped image of the patient. After the data is collected, an image (e.g., a combined OCT and IVUS image) of the blood vessel and any associated intraluminal structures, such as plaque, thrombus, stent, etc., can be reconstructed using well-known techniques. This image is then visually analyzed by a physician to assess the vessel components and plaque content.

Image analysis of data collected from use of the present invention includes determining the size of the lumen and amount of plaque in the vessel. This is performed by generating an image of the vessel (e.g., combined OCT and IVUS image) and manually drawing contoured boundaries on the image where the clinician believes the luminal and the medial-adventitial borders are located. In other words, the luminal border, which demarcates the blood-intima interface, and the medial-adventitial border, which demarcates the external elastic membrane or the boundary between the media and the adventitia, are manually drawn to identify the plaque-media complex that is located there between.

As illustrated generally in FIG. 1, the OCT-IVUS system **100** of present invention includes a proximal end and a distal end. The proximal end of the OCT-IVUS system **100** includes a rotary optical fiber connector **101**, sometimes also referred to in the art as a fiber optical rotary joint ("FORJ"). The optical fiber connector **101** joins two optical fibers, one optical fiber **105** that is stationary and proximal to the optical fiber connector **101** and another optical fiber **106** that is rotatable and distal to the optical fiber connector **101**. Different types of optical fiber connectors **101**, e.g., SC-APC plug-in connector, have been developed in the art for various applications and are encompassed by the present invention. A distal end catheter assembly **111**, shown in greater detail in FIG. 3, consists generally of the OCT assembly and the ultrasound transducer **120** positioned with a housing **110**, that is coupled at its proximal end to a rotary drive shaft **104**, that, in turn, is coupled to a rotary drive actuator, such as that illustrated in and described with reference to FIG. 2.

Turning to FIG. 2, a rotary actuation system, which includes a rotary motor **102**, an optical fiber connector **101**, and gears **103**, is illustrated rotating a driveshaft **104**. The driveshaft **104** itself is comprised of a fitting (not shown) that overlies and houses the optical fiber **106** distal to the optical fiber connector **101**. This rotary actuation system

may also include a linear actuation system (not shown) to facilitate manual or automated pull-back of the catheter.

FIG. 3 provides a closer side view of the distal end of the OCT-IVUS system **100** depicted in FIG. 1. The catheter assembly **111** includes an outer catheter sheath **113** that terminates at a distal end thereof in a distal tip **200** having a guidewire lumen **161** configured for rapid guidewire exchange. The outer catheter sheath **113** is preferably at least partially, preferably near totally, transparent to both optical and ultrasonic energy to permit transmission of optical and ultrasonic energy to and from the IVUS-OCT catheter assembly **111**. Co-pending, commonly assigned U.S. Provisional Patent Application Ser. No. 60/949,511, filed Jul. 12, 2007, from which priority is claimed, describes a monolithic catheter construct and rotary drive system well-suited for use with the present invention, and is hereby incorporated by reference thereto as if fully set forth herein.

A driveshaft **104** extends from the proximal end of the OCT-IVUS system **100** into the catheter assembly **111**. In one embodiment, the outer surface of the catheter assembly **111** is covered and protected by an outer sheath formed of PFA (perfluoroalkoxy). To avoid damage to blood vessels, sheaths may also be formed of other flexible plastic-type materials, having high hoop strengths or with reinforcements, to help stop this kinking and bending while reducing tissue damage during catheter introduction. Other appropriate materials known in the art for use as an outer sheath are also within the scope of the present invention.

The catheter assembly **111** includes, but is not limited to, a protection bearing **110**, a ferrule **114**, a GRIN lens assembly **116**, a prism **118**, an OCT imaging port **117**, an optical fiber **106**, and an IVUS transducer **120**, all of which are housed within the protection bearing **110**. The catheter assembly **111** may also include a rapid exchange section **160** which has a guidewire lumen **161** that extends between a guidewire entrance port **162** and a guidewire exit port **164**. The protection bearing **110** serves as a shield for OCT and IVUS components. The protection bearing **110** has at least one transparent portion **117**, which is preferably an opening through the protection bearing **110** that is transparent to both optical and ultrasound energy to permit transmission of such energy to and from the OCT assembly and the ultrasound transducer. The at least one transparent portion **117** may be positioned through a wall of the protection bearing **110** or through an end of the protection bearing **110**.

FIG. 4 illustrates one embodiment of the invention, wherein an ultrasound transducer **120** is positioned proximal to the OCT assembly (i.e., ferrule **114**, GRIN lens assembly **116**, and prism **118**). In this embodiment, the ultrasound transducer **120** possesses a cylindrical structure with a hollow core to provide access for an optical fiber **106** to pass through to the OCT assembly. Electrical conduits or wires **122** provide electrically couple the ultrasound transducer **120** to a power source (not shown) and to an ultrasound receiver (not shown).

FIG. 5 illustrates another embodiment of the invention, wherein an ultrasound transducer **120** is formed on or as a part of the ferrule **114** of the OCT assembly. FIG. 6 provides a perspective view of the ferrule **114** with the ultrasound transducer **120** embedded with a wall of the ferrule **114**. Similar to the embodiment illustrated in FIG. 4, in this embodiment, conduits or wires **122** provide power to the ultrasound transducer **120** and electrically connect the transducer to the ultrasound receiver (not shown).

FIG. 7 illustrates another embodiment of the invention, wherein the ultrasound transducer **120** is positioned distal to the OCT assembly and is generally forward-looking. In this

embodiment, wires **122** extend across the OCT assembly and connect to the ultrasound transducer **120** to provide power.

Turning to FIGS. **8** and **9** the optical fiber **106** described above is formed of a core **140** and two layers, a cladding **142** layer and a buffer **144** layer, surrounding the core **140**. At least two electrical conduits or wires **146** are operably associated with wall surfaces of the buffer layer **144**, but may, alternatively, be associated with the cladding layer **142** or the core **140**.

In the preferred embodiment of the present invention, the optical fiber core **140** is formed of glass made from silica. Nonetheless, other materials known in the art, such as fluorozirconate, fluoroaluminate, and chalcogenide glasses, which are used for longer-wavelength infrared applications, are also within the scope of the present invention. Like other glasses, these glasses have a refractive index of about 1.5. Typically the difference between core and cladding is less than one percent.

As known in the art, the cladding **142** may be formed of a material has a slightly lower refractive index (faster speed) in order to keep the light in the core. The cladding **142** and core **140** make up an optical waveguide.

The cladding **142** is usually coated with a tough resin buffer **144** layer, which may be further surrounded by a jacket layer (not shown), usually plastic. As known in the art, the buffer material surrounding the cladding of a fiber may be a soft plastic material that protects the core **140** from damage. These layers add strength to the fiber but do not contribute to its optical wave guide properties. Rigid fiber assemblies sometimes put light-absorbing (“dark”) glass between the fibers, to prevent light that leaks out of one fiber from entering another. This reduces cross-talk between the fibers, or reduces flare in fiber bundle imaging applications.

FIG. **8** illustrates one embodiment of the optical fiber **106**, wherein the wires **122** (shown in FIGS. **4**, **5**, and **7** to be interwinding) are embedded or otherwise coupled on top of the buffer **144** layer of the optical fiber **106**. The wires may be formed of metal films vacuum deposited onto the optical fiber or otherwise operably associated with the optical fiber. In another embodiment, as illustrated in FIG. **9**, the wires **146** are embedded within the buffer **144** layer of the optical fiber **106**.

The present invention may be embodied in other specific forms without departing from its spirit or essential characteristics. The described embodiments are to be considered in all respects only as illustrative and not restrictive. Therefore, the scope of the invention is not limited to the specific exemplary embodiment described above. All changes or modifications within the meaning and range of equivalents are intended to be embraced herein.

As used in this application, the articles “a” and “an” refer to one or more than one (i.e., to at least one) of the grammatical objects of the article. By way of example, “an element” means one element or more than one element.

What is claimed:

1. A catheter comprising:

an elongate catheter assembly defining a lumen and comprising an outer catheter sheath;

an imaging assembly disposed within the lumen and comprising an optical coherence tomography (OCT) assembly and an ultrasound transducer, wherein the OCT assembly comprises a ferrule, and wherein the ultrasound transducer is embedded within a wall of the ferrule of the OCT assembly;

an optical fiber connected to the OCT assembly and comprising a core and a surrounding layer; and

an electrical wire connected to the ultrasound transducer, wherein the electrical wire is coupled to the core or the surrounding layer of the optical fiber such that the electrical wire and the optical fiber function together as mechanical elements for rotating the imaging assembly;

wherein the catheter assembly comprises a protection bearing that houses the OCT assembly, the ultrasound transducer, a portion of the optical fiber, and a portion of the electrical wire within the lumen of the catheter assembly and is configured to shield the OCT assembly and the ultrasound transducer, wherein the protection bearing is a tubular housing;

wherein the OCT assembly and the ultrasound transducer are arranged to obtain imaging data in the same direction through a side of the outer catheter sheath while the imaging assembly rotates such that the OCT assembly and the ultrasound transducer are configured to scan the same or at least partially overlapping spatial areas.

2. The catheter of claim **1**, wherein the OCT assembly comprises a gradient index (GRIN) lens assembly and a prism.

3. The catheter of claim **1**, wherein at least a portion of the catheter assembly is comprised of a transparent material.

4. The catheter of claim **1**, wherein the catheter assembly comprises a material selected from the group consisting of perfluoroalkoxy, polytetrafluoroethylene, fluorinated ethylene propylene, and polyether block amide.

5. The catheter of claim **1**, wherein the protection bearing comprises a transparent portion located on a side wall or an end wall of the protection bearing.

6. The catheter of claim **1**, wherein the ferrule of the OCT assembly comprises a hollow core, and wherein the optical fiber extends through the hollow core.

7. The catheter of claim **1**, wherein the surrounding layer of the optical fiber comprises a cladding layer and a buffer layer, and wherein the electrical wire is coupled to the buffer layer.

8. The catheter of claim **1**, wherein the surrounding layer of the optical fiber comprises a cladding layer and a buffer layer, and wherein the electrical wire is embedded within the buffer layer of the optical fiber.

9. A catheter comprising:

an elongate catheter assembly defining a lumen and comprising an outer catheter sheath;

an imaging assembly disposed within the lumen and comprising an optical coherence tomography (OCT) assembly and an ultrasound transducer, wherein the OCT assembly comprises a ferrule comprising a cylindrical body, and wherein the ultrasound transducer comprises an angular portion of the cylindrical body;

an optical fiber connected to the OCT assembly and comprising a core and a surrounding layer; and
an electrical wire connected to the ultrasound transducer, wherein the electrical wire is coupled to the core or the surrounding layer of the optical fiber such that the electrical wire and the optical fiber function together as mechanical elements for rotating the imaging assembly;

wherein the catheter assembly comprises a protection bearing that houses the OCT assembly, the ultrasound transducer, a portion of the optical fiber, and a portion of the electrical wire within the lumen of the catheter assembly and is configured to shield the OCT assembly and the ultrasound transducer, wherein the protection bearing is a tubular housing;

wherein the OCT assembly and the ultrasound transducer are arranged to obtain imaging data in the same direction through a side of the outer catheter sheath while the imaging assembly rotates such that the OCT assembly and the ultrasound transducer are configured to scan the same or at least partially overlapping spatial areas. 5

10. The catheter of claim 9, wherein the OCT assembly comprises a gradient index (GRIN) lens assembly and a prism.

11. The catheter of claim 9, wherein at least a portion of the catheter assembly is comprised of a transparent material. 10

12. The catheter of claim 9, wherein the catheter assembly comprises a material selected from the group consisting of perfluoroalkoxy, polytetrafluoroethylene, fluorinated ethylene propylene, and polyether block amide. 15

13. The catheter of claim 9, wherein the protection bearing comprises a transparent portion located on a side wall or an end wall of the protection bearing.

14. The catheter of claim 9, wherein the ferrule of the OCT assembly comprises a hollow core, and wherein the optical fiber extends through the hollow core. 20

15. The catheter of claim 9, wherein the surrounding layer of the optical fiber comprises a cladding layer and a buffer layer, and wherein the electrical wire is coupled to the buffer layer. 25

16. The catheter of claim 9, wherein the surrounding layer of the optical fiber comprises a cladding layer and a buffer layer, and wherein the electrical wire is embedded within the buffer layer of the optical fiber.

* * * * *

30

专利名称(译)	OCT-IVUS导管用于并行腔内成像		
公开(公告)号	US10219780	公开(公告)日	2019-03-05
申请号	US12/173004	申请日	2008-07-14
[标]申请(专利权)人(译)	火山公司		
申请(专利权)人(译)	火山CORPORATION		
当前申请(专利权)人(译)	火山CORPORATION		
[标]发明人	CASTELLA PAUL KEMP NATHANIEL J MILNER THOMAS E ROSENBAUM DAVID G		
发明人	CASTELLA, PAUL KEMP, NATHANIEL J. MILNER, THOMAS E. ROSENBAUM, DAVID G.		
IPC分类号	A61B8/12 A61B5/00 A61B5/02 A61B8/08		
CPC分类号	A61B8/12 A61B5/0066 A61B5/6852 A61B5/02007 A61B8/486		
优先权	60/949511 2007-07-12 US 60/949472 2007-07-12 US		
其他公开文献	US20090043191A1		
外部链接	Espacenet		

摘要(译)

本发明涉及一种用于体内成像的装置。更具体地，本发明涉及一种导管，其包括光学相干断层扫描（OCT）系统和血管内超声（“IVUS”）系统，用于腔内系统的同时成像，例如对脉管系统成像，包括但不限于心脏血管系统，外周血管系统和神经管系统。

