



US009358072B2

(12) **United States Patent**
Ullrich

(10) **Patent No.:** **US 9,358,072 B2**
(45) **Date of Patent:** **Jun. 7, 2016**

(54) **SYSTEMS AND METHODS FOR MINIMALLY INVASIVE SURGICAL TOOLS WITH HAPTIC FEEDBACK**

(75) Inventor: **Christopher J. Ullrich**, Ventura, CA (US)

(73) Assignee: **Immersion Corporation**, San Jose, CA (US)

(*) Notice: Subject to any disclaimer, the term of this patent is extended or adjusted under 35 U.S.C. 154(b) by 481 days.

(21) Appl. No.: **13/007,251**

(22) Filed: **Jan. 14, 2011**

(65) **Prior Publication Data**

US 2011/0178508 A1 Jul. 21, 2011

Related U.S. Application Data

(60) Provisional application No. 61/295,438, filed on Jan. 15, 2010.

(51) **Int. Cl.**

A61M 25/01 (2006.01)
A61B 19/00 (2006.01)
A61B 17/00 (2006.01)
A61B 5/00 (2006.01)
A61B 5/0205 (2006.01)
A61B 5/042 (2006.01)

(52) **U.S. Cl.**

CPC **A61B 19/22** (2013.01); **A61B 17/00234** (2013.01); **A61M 25/01** (2013.01); **A61B 5/0084** (2013.01); **A61B 5/0205** (2013.01); **A61B 5/042** (2013.01); **A61B 19/2203** (2013.01); **A61B 2019/2211** (2013.01); **A61B 2019/2292** (2013.01); **A61B 2019/2296** (2013.01); **A61B 2019/465** (2013.01); **A61M 25/0113** (2013.01); **A61M 25/0116** (2013.01)

(58) **Field of Classification Search**

None
See application file for complete search history.

(56) **References Cited**

U.S. PATENT DOCUMENTS

5,080,104 A * 1/1992 Marks et al. 600/461
5,320,608 A * 6/1994 Gerrone A61B 17/3417
604/117

5,339,799 A 8/1994 Kami et al.
5,389,849 A 2/1995 Asano et al.

(Continued)

FOREIGN PATENT DOCUMENTS

CA 2 520 942 3/2007
DE 42 13 426 A1 10/1992

(Continued)

OTHER PUBLICATIONS

The Macmillan Encyclopedia, Electrocardiography, Market House Books Ltd 2003.*

(Continued)

Primary Examiner — Lynsey Crandall

Assistant Examiner — Manolis Pahakis

(74) *Attorney, Agent, or Firm* — Kilpatrick Townsend & Stockton LLP

(57) **ABSTRACT**

Systems and methods for minimally invasive surgical tools with haptic feedback are disclosed. One disclosed embodiment of a system includes an insertion sheath configured to be partially inserted within a patient's body, the insertion sheath configured to receive a surgical tool; a roller disposed at least partially within the insertion sheath, the roller configured to contact a surgical tool inserted within the insertion sheath; and an actuator coupled to the roller, the actuator configured to receive an actuator signal and to output a haptic effect based on the actuator signal.

24 Claims, 8 Drawing Sheets

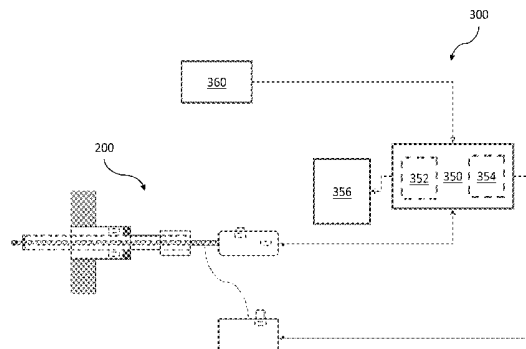
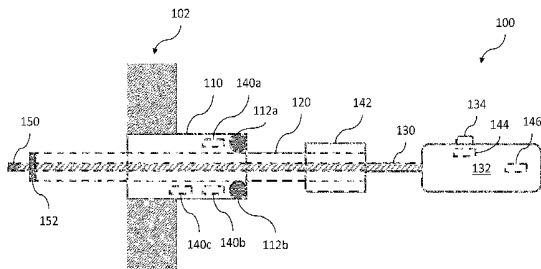

(56)

References Cited

- U.S. PATENT DOCUMENTS
- 5,431,645 A * 7/1995 Smith et al. 606/1
5,480,422 A * 1/1996 Ben-Haim 607/122
5,540,681 A * 7/1996 Strul et al. 606/34
5,667,517 A * 9/1997 Hooven 606/151
5,720,742 A * 2/1998 Zacharias 606/1
5,728,044 A * 3/1998 Shan A61B 1/31
33/512
- 5,755,668 A 5/1998 Itoigawa et al.
5,805,140 A * 9/1998 Rosenberg et al. 345/161
5,810,841 A * 9/1998 McNeirney et al. 606/130
5,821,920 A * 10/1998 Rosenberg et al. 345/156
5,833,634 A 11/1998 Laird et al.
5,853,392 A * 12/1998 Dennis 604/164.01
5,929,846 A * 7/1999 Rosenberg et al. 345/161
6,088,020 A * 7/2000 Mor B25J 13/02
318/628
- 6,096,004 A * 8/2000 Meglan A61B 19/22
604/95.01
- 6,154,201 A * 11/2000 Levin et al. 345/184
6,171,234 B1 1/2001 White et al.
6,184,868 B1 * 2/2001 Shahoian et al. 345/161
6,224,586 B1 5/2001 Stephens
6,373,465 B2 * 4/2002 Jolly et al. 345/156
6,377,011 B1 * 4/2002 Ben-Ur 318/566
6,470,302 B1 * 10/2002 Cunningham et al. 703/7
6,612,992 B1 * 9/2003 Hossack A61B 5/06
600/467
- 6,697,044 B2 * 2/2004 Shahoian et al. 345/156
6,717,573 B1 * 4/2004 Shahoian et al. 345/161
6,726,675 B1 * 4/2004 Beyar 604/510
6,776,765 B2 * 8/2004 Soukup et al. 600/585
6,817,973 B2 * 11/2004 Merrill et al. 600/118
6,834,647 B2 * 12/2004 Blair et al. 128/204.18
6,929,481 B1 * 8/2005 Alexander et al. 434/262
7,056,123 B2 * 6/2006 Gregorio et al. 434/272
7,196,688 B2 * 3/2007 Schena 345/156
7,198,137 B2 * 4/2007 Olien 188/1.11 E
7,289,106 B2 * 10/2007 Bailey et al. 345/158
7,300,450 B2 11/2007 Vleugels et al.
7,344,507 B2 * 3/2008 Briggs et al. 600/583
7,344,533 B2 * 3/2008 Pearson et al. 606/41
7,522,152 B2 * 4/2009 Olien et al. 345/156
7,570,254 B2 * 8/2009 Suzuki et al. 345/184
7,669,598 B2 * 3/2010 Rick et al. 128/204.21
7,815,436 B2 * 10/2010 Cunningham et al. 434/262
7,819,799 B2 * 10/2010 Merrill et al. 600/118
7,877,243 B2 * 1/2011 Olien et al. 703/3
7,963,925 B1 * 6/2011 Schecter 600/508
7,972,141 B2 * 7/2011 Morris 434/268
8,002,089 B2 * 8/2011 Jasso et al. 188/83
8,043,229 B2 * 10/2011 Mulvihill et al. 600/568
8,128,622 B2 * 3/2012 Podhajsky et al. 606/47
8,187,229 B2 * 5/2012 Weitzner et al. 604/158
8,221,308 B2 * 7/2012 Noguchi et al. 600/117
8,292,831 B2 * 10/2012 Fausett A61B 5/1114
600/587
- 8,328,738 B2 * 12/2012 Frankhouser et al. 600/587
8,715,271 B2 5/2014 Fujimoto et al.
8,942,828 B1 * 1/2015 Schecter 607/122
8,998,890 B2 * 4/2015 Paul A61N 1/40
600/547
- 2001/0025150 A1 * 9/2001 de Juan, Jr. A61B 5/6848
600/587
- 2002/0120188 A1 * 8/2002 Brock et al. 600/407
2003/0187343 A1 * 10/2003 Cuzzani A61B 3/16
600/399
- 2004/0106916 A1 * 6/2004 Quaid A61B 19/2203
606/1
- 2004/0167559 A1 8/2004 Taylor et al.
2004/0210186 A1 * 10/2004 Arnett et al. 604/35
2005/0021078 A1 * 1/2005 Vleugels A61B 17/29
606/205
- 2005/0214723 A1 * 9/2005 Feygin et al. 434/262
- 2005/0245910 A1 * 11/2005 Wright A61F 9/00745
606/1
- 2006/0041245 A1 2/2006 Ferry et al.
2006/0142657 A1 6/2006 Quaid et al.
2006/0146010 A1 * 7/2006 Schneider 345/156
2006/0161045 A1 7/2006 Merrill et al.
2007/0004984 A1 * 1/2007 Crum et al. 600/471
2007/0018958 A1 * 1/2007 Tavakoli A61B 19/2203
345/161
- 2007/0063971 A1 * 3/2007 Vecerina et al. 345/156
2007/0103437 A1 * 5/2007 Rosenberg 345/161
2007/0129626 A1 * 6/2007 Mahesh et al. 600/407
2007/0135735 A1 * 6/2007 Ellis A61B 5/11
600/587
- 2007/0142749 A1 * 6/2007 Khatib A61B 6/12
600/587
- 2007/0149931 A1 * 6/2007 Cannon et al. 604/264
2007/0152974 A1 * 7/2007 Kim et al. 345/168
2007/0197939 A1 * 8/2007 Wallace et al. 600/587
2007/0233044 A1 10/2007 Wallace
2007/0299304 A1 12/2007 Murakami et al.
2008/0009791 A1 1/2008 Cohen et al.
2008/0221439 A1 * 9/2008 Iddan et al. 600/424
2008/0228104 A1 * 9/2008 Uber et al. 600/567
2008/0249395 A1 * 10/2008 Shachar et al. 600/409
2008/0275442 A1 11/2008 Paul et al.
2008/0275465 A1 * 11/2008 Paul et al. 606/129
2008/0297287 A1 * 12/2008 Shachar et al. 335/234
2008/0319279 A1 * 12/2008 Ramsay et al. 600/301
2009/0030332 A1 * 1/2009 Schecter 600/508
2009/0062686 A1 * 3/2009 Hyde et al. 600/558
2009/0156921 A1 * 6/2009 Wang 600/364
2009/0158852 A1 6/2009 Paul et al.
2009/0234273 A1 * 9/2009 Intoccia A61B 17/3417
604/22
- 2009/0248042 A1 * 10/2009 Kirschenman A61B 19/2203
606/130
- 2009/0281478 A1 * 11/2009 Duke 604/22
2009/0306547 A1 * 12/2009 Iddan et al. 600/585
2010/0057099 A1 * 3/2010 Fujimoto et al. 606/130
2010/0073150 A1 * 3/2010 Olson A61B 19/2203
340/407.1
- 2010/0095961 A1 * 4/2010 Tornesel et al. 128/203.12
2010/0152586 A1 * 6/2010 Grant A61B 5/489
600/454
- 2010/0161022 A1 * 6/2010 Tolkowsky 623/1.11
2010/0168572 A1 * 7/2010 Sliwa A61B 8/0833
600/439
- 2010/0178644 A1 * 7/2010 Meglan et al. 434/267
2010/0249796 A1 * 9/2010 Nycz A61B 19/5244
606/99
- 2010/0312129 A1 * 12/2010 Schecter A61B 5/0031
600/508
- 2011/0015569 A1 * 1/2011 Kirschenman A61B 17/2909
604/95.01
- 2011/0046659 A1 2/2011 Ramstein et al.
2011/0152882 A1 * 6/2011 Wenderow et al. 606/130
2011/0152901 A1 * 6/2011 Woodruff A61F 5/0056
606/157
- 2011/0319815 A1 * 12/2011 Roelle A61B 1/00149
604/95.01
- 2012/0041436 A1 * 2/2012 Ullrich A61B 18/12
606/39
- 2013/0274712 A1 * 10/2013 Schecter A61M 25/10
604/510
- FOREIGN PATENT DOCUMENTS
- EP 1 108 394 A2 6/2001
JP 2006-325916 12/2006
WO WO 03/020139 A2 3/2003
WO WO 2004/067053 A2 8/2004
WO WO 2005/013803 A2 2/2005
WO WO 2006/091494 A1 * 8/2006
WO WO 2006/120666 A1 * 11/2006
WO WO 2007/051000 5/2007

(56)

References Cited

FOREIGN PATENT DOCUMENTS

WO WO 2008/085919 7/2008
WO WO 2009009220 A2 * 1/2009 A61B 17/00

OTHER PUBLICATIONS

Patent Cooperation Treaty, International Search Report and Written Opinion, Application No. PCT/US2011/021349, mailed Jun. 16, 2011.

Patent Cooperation Treaty, International Search Report, International Application No. PCT/US2008/063561, dated Jan. 30, 2009.

European Patent Office, Communication pursuant to Article 94(3) EPC, European Application No. 11703519, dated Mar. 5, 2014.

Japanese Patent Office, Office Action, Application No. 2012-549125, dated Sep. 16, 2014.

Patent Cooperation Treaty, Preliminary Report on Patentability, International Application No. PCT/US2011/021349, dated Jul. 26, 2012.

* cited by examiner

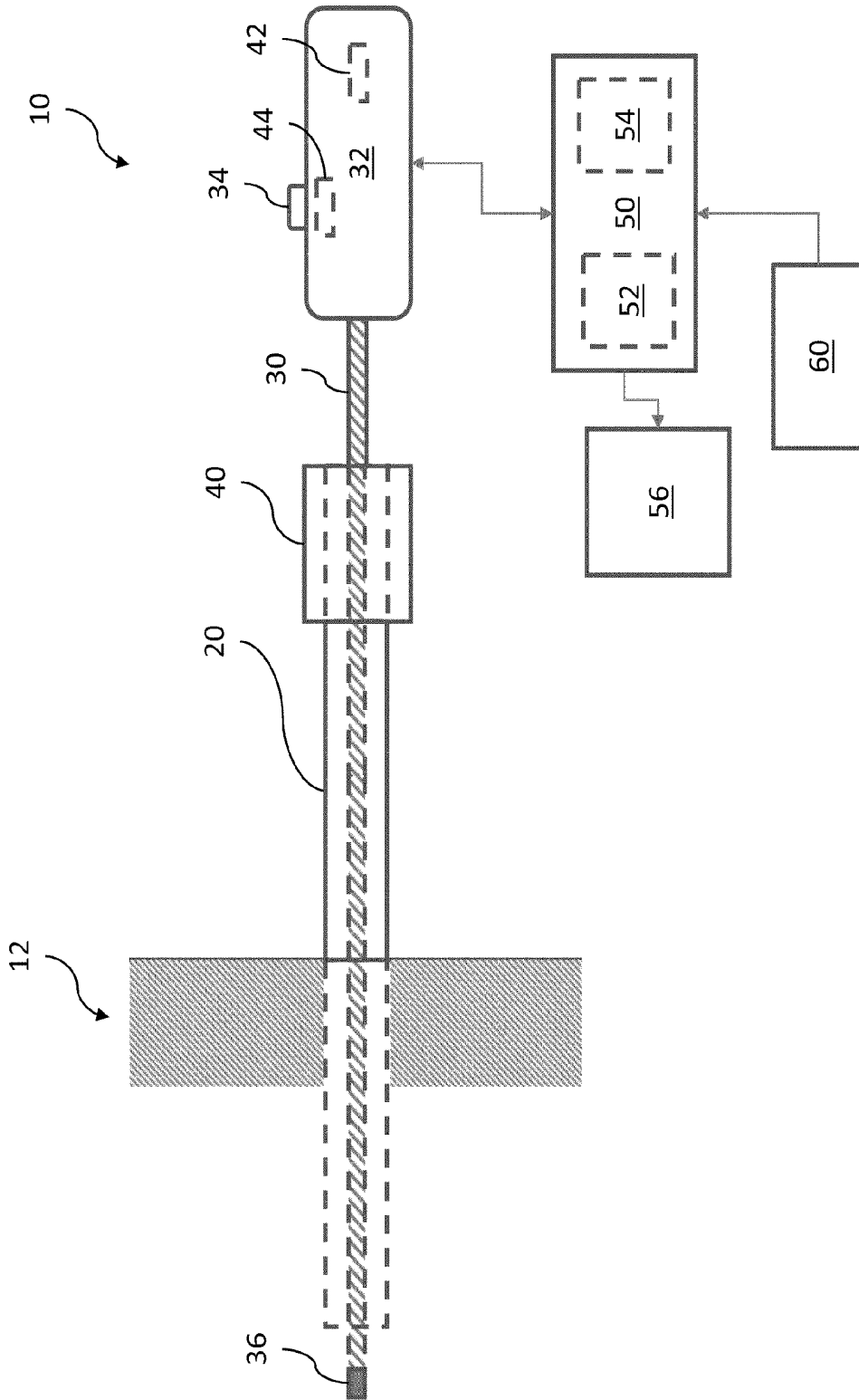

Figure 1

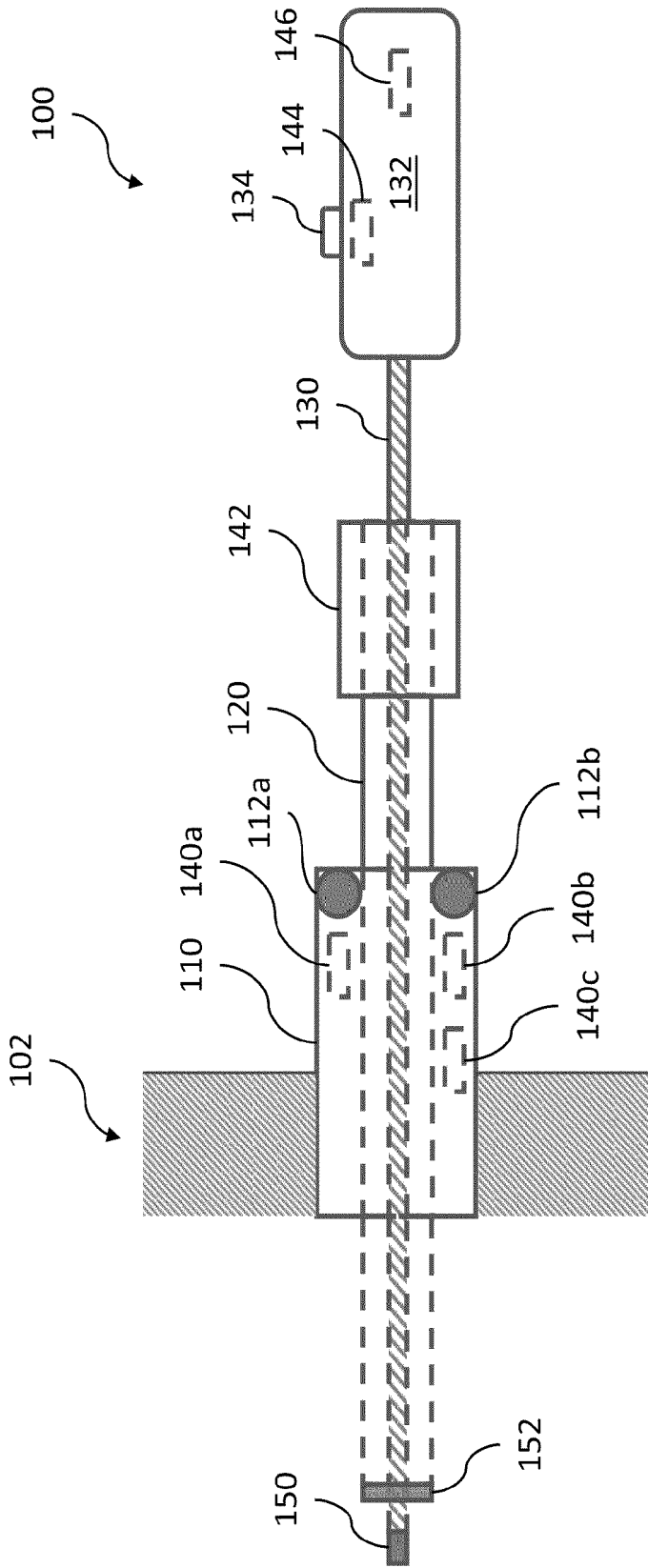

Figure 2a

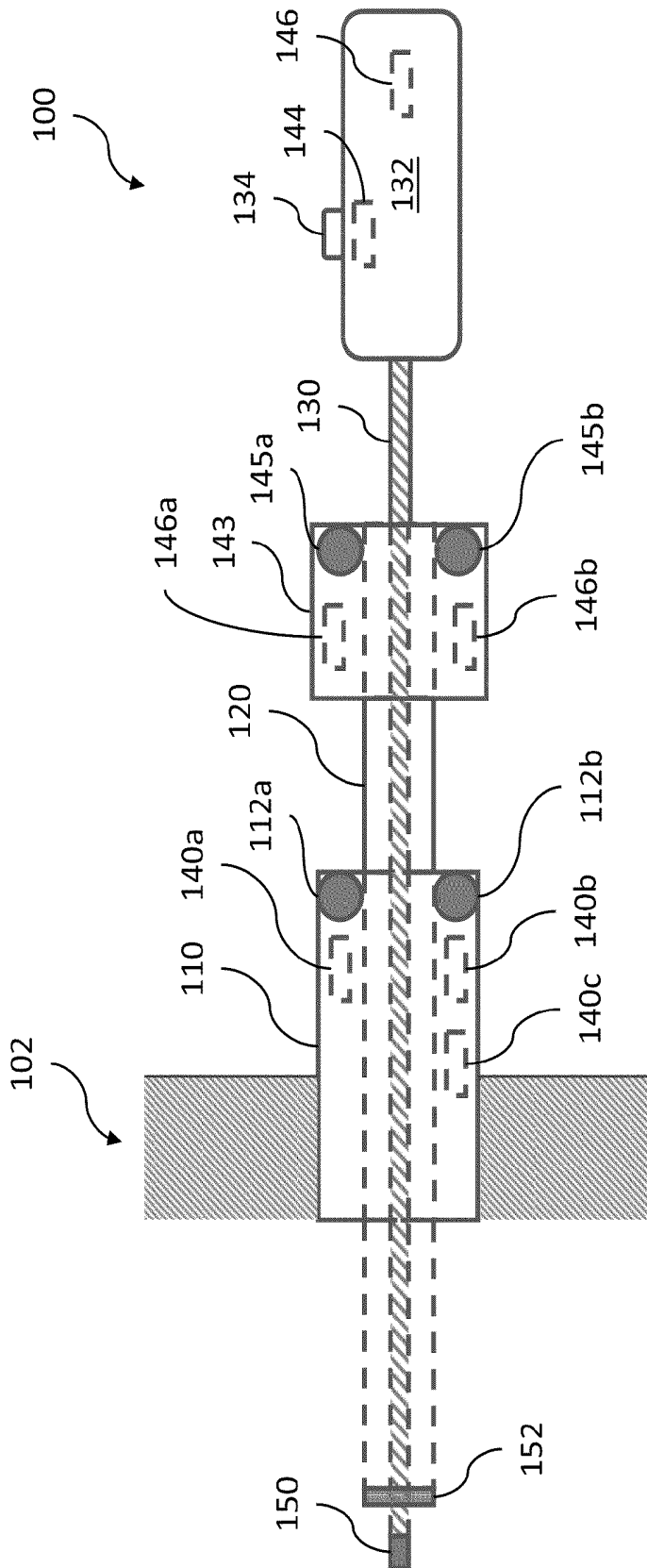

Figure 2b

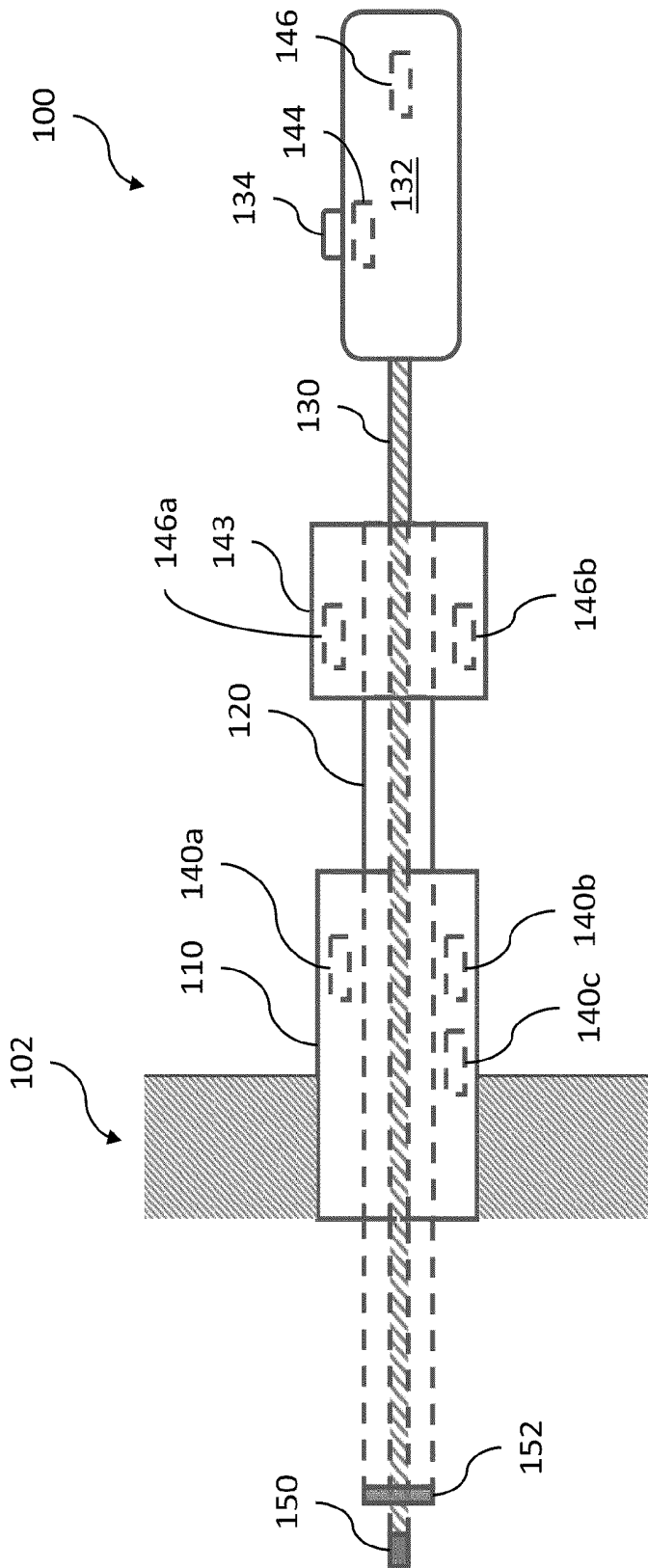

Figure 2c

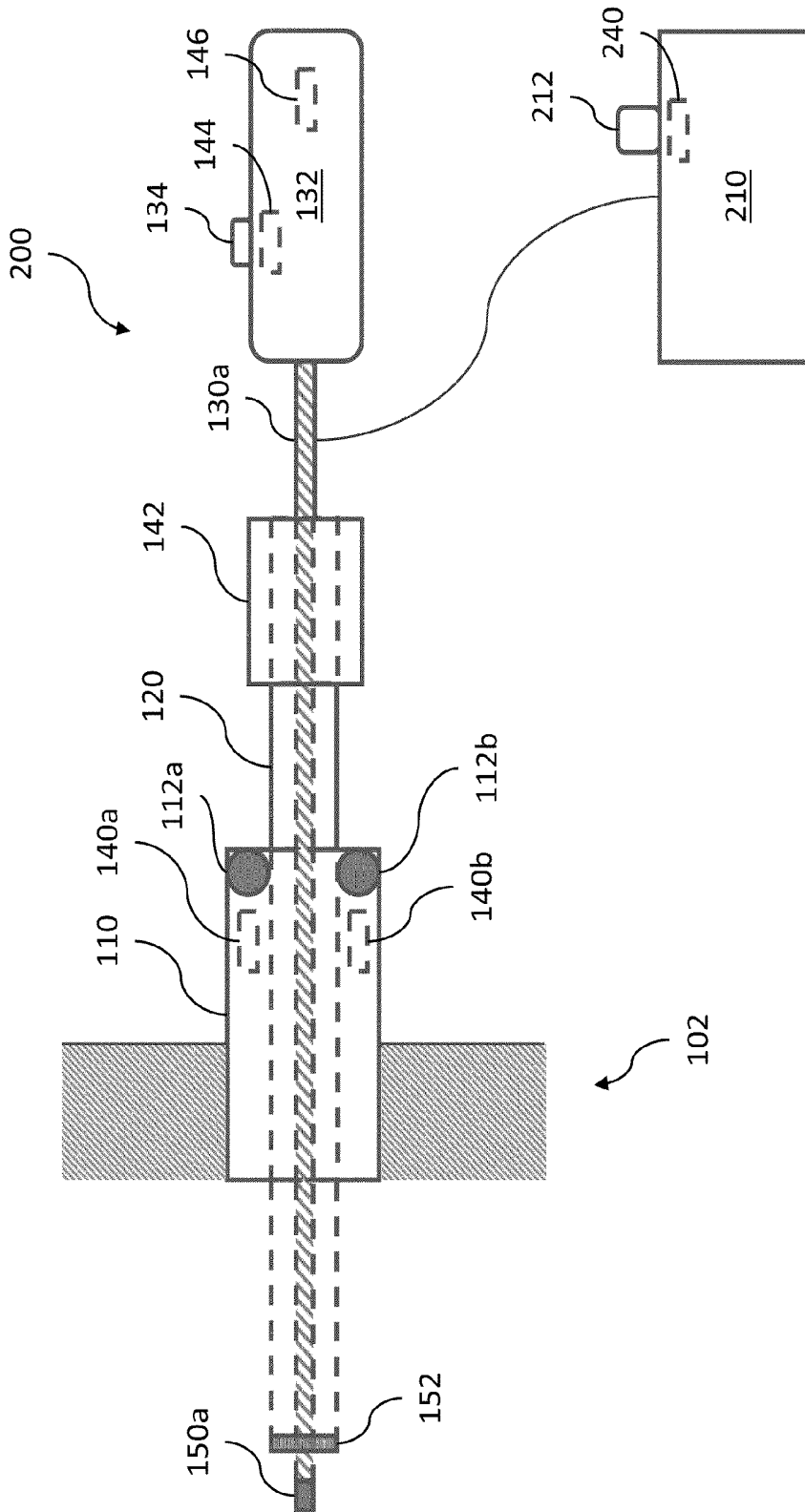

Figure 3

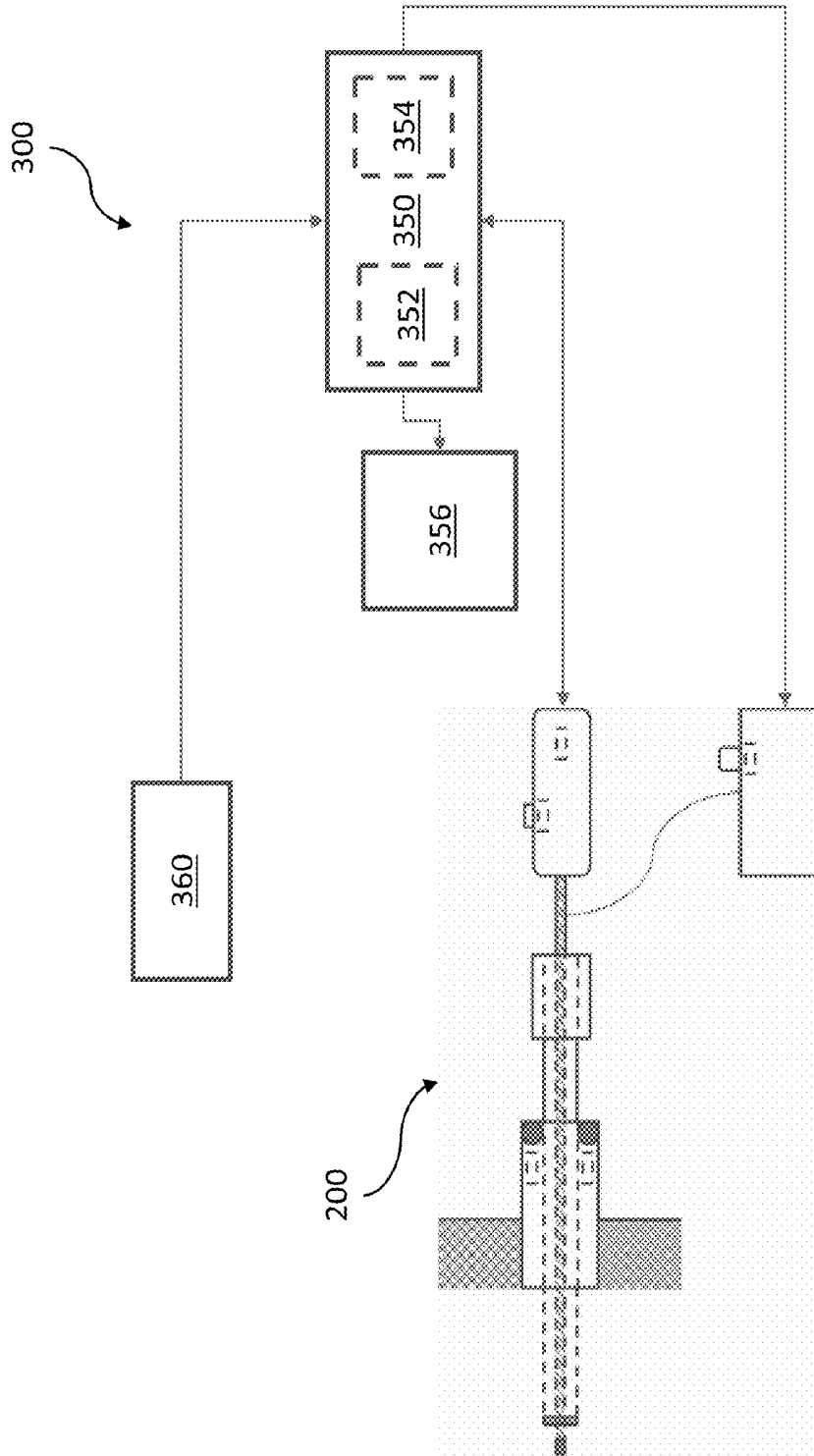

Figure 4a

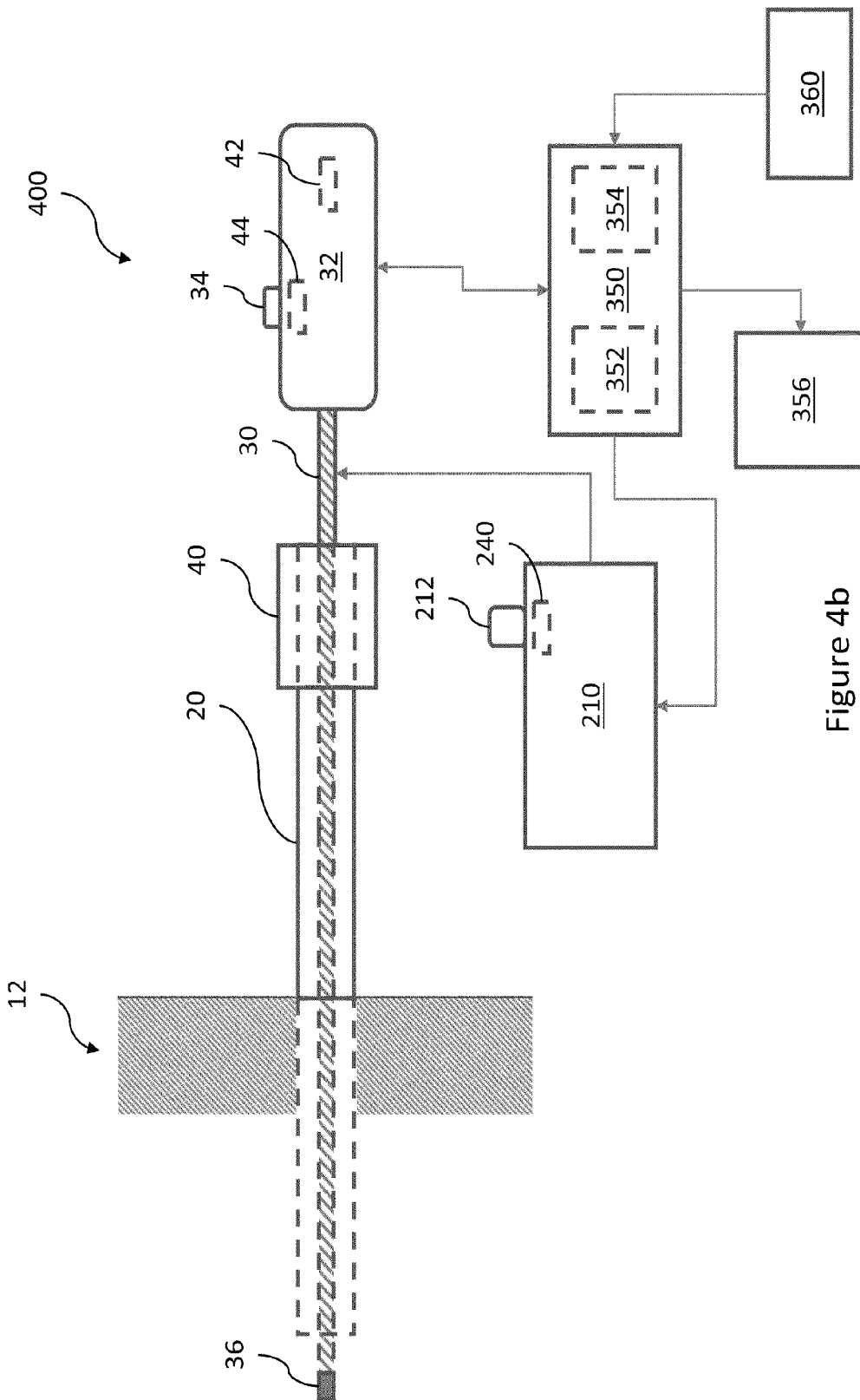

Figure 4b

500

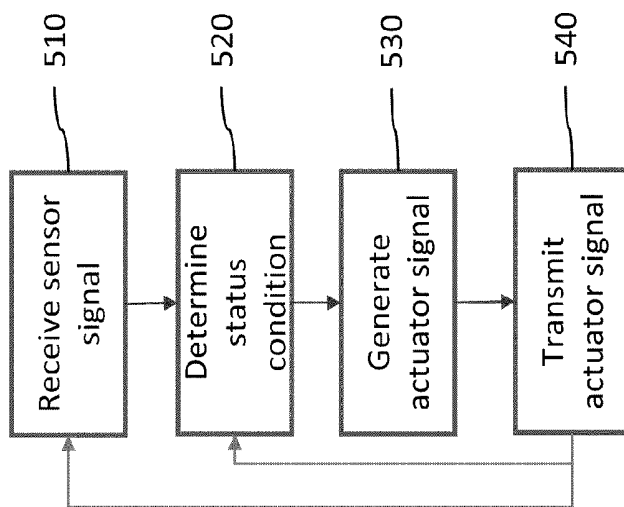

Figure 5

SYSTEMS AND METHODS FOR MINIMALLY INVASIVE SURGICAL TOOLS WITH HAPTIC FEEDBACK

CROSS-REFERENCES TO RELATED APPLICATION

This application claims priority to U.S. Provisional Patent Application No. 61/295,438 filed Jan. 15, 2010, entitled Minimally Invasive Surgical Tools with Haptic Feedback, the entirety of which is hereby incorporated by reference.

FIELD OF THE INVENTION

The present invention generally relates to surgical tools and more specifically to systems and methods for medical simulation and more particularly to systems and methods for minimally invasive surgical tools with haptic feedback.

BACKGROUND

Minimally invasive surgery is performed without making a major incision or opening, resulting in reduced trauma for the patient and yielding significant cost savings. These result from shorter hospitalization times and reduced therapy requirements. Other benefits of minimally invasive surgery include less pain, less need for post-surgical pain medication, less scarring, and less likelihood of complications related to the incision.

Minimally invasive surgery is defined either as based on the operative procedure (e.g., small incisions) or the outcome (e.g., reduced surgical complications or costs). However, minimally invasive surgery is not the same as minor surgery. Some “minimally invasive” procedures, e.g., coronary artery bypass surgery, still are major operations requiring a hospital stay.

In minimally invasive surgery, a miniature camera is typically introduced into the body through a small incision. The camera transmits images to a video monitor, enabling the physician to diagnose and, if necessary, treat a variety of conditions. To do this, the physician inserts surgical instruments and auxiliary devices (collectively, “minimally invasive surgical tools”), such as irrigation and drainage devices, through one or more additional small incisions. Such surgical instruments can be for laparoscopic surgery, catheterization or endoscopy, as well as for enabling telesurgery and telepresence. Compared to open surgery, however, minimally invasive surgery presents limitations in visual and haptic perceptions, and creates challenges unique to this type of surgery. One of the major concerns is the potential for tissue damage, possibly caused by inappropriate use of force.

SUMMARY

Embodiments of the present invention provide systems and methods for minimally invasive surgical tools with haptic feedback. For example, in one embodiment, a system includes an insertion sheath configured to be partially inserted within a patient’s body, the insertion sheath configured to receive a surgical tool; a roller disposed at least partially within the insertion sheath, the roller configured to contact a surgical tool inserted within the insertion sheath; and an actuator coupled to the roller, the actuator configured to receive an actuator signal and to output a haptic effect based on the actuator signal.

In one embodiment of a method, the method comprises a computer-implemented method, comprising receiving a sensor signal from a sensor coupled to a surgical tool, the surgical tool configured to be at least partially inserted within a patient’s body; generating an actuator signal based at least in part on the sensor signal, the actuator signal configured to cause the actuator to output a haptic effect; and transmitting the actuator signal to an actuator coupled to the surgical tool. In another embodiment, a computer-readable medium comprises program code for causing a processor to execute such a method

These illustrative embodiments are mentioned not to limit or define the invention, but rather to provide examples to aid understanding thereof. Illustrative embodiments are discussed in the Detailed Description, which provides further description of the invention. Advantages offered by various embodiments of this invention may be further understood by examining this specification.

BRIEF DESCRIPTION OF THE DRAWINGS

The accompanying drawings, which are incorporated into and constitute a part of this specification, illustrate one or more examples of embodiments and, together with the description of example embodiments, serve to explain the principles and implementations of the embodiments.

FIG. 1 shows an illustrative system for minimally invasive surgical tools with haptic feedback according to one embodiment of the present invention;

FIGS. 2-3 show systems for minimally invasive surgical tools with haptic feedback according to embodiments of the present invention;

FIGS. 4a-b show systems for minimally invasive surgical tools with haptic feedback according to embodiments of the present invention; and

FIG. 5 shows a method for minimally invasive surgical tools with haptic feedback according to one embodiment of the present invention.

DETAILED DESCRIPTION

Example embodiments are described herein in the context of systems and methods for minimally invasive surgical tools with haptic feedback. Those of ordinary skill in the art will realize that the following description is illustrative only and is not intended to be in any way limiting. Other embodiments will readily suggest themselves to such skilled persons having the benefit of this disclosure. Reference will now be made in detail to implementations of example embodiments as illustrated in the accompanying drawings. The same reference indicators will be used throughout the drawings and the following description to refer to the same or like items.

In the interest of clarity, not all of the routine features of the implementations described herein are shown and described. It will, of course, be appreciated that in the development of any such actual implementation, numerous implementation-specific decisions must be made in order to achieve the developer’s specific goals, such as compliance with application- and business-related constraints, and that these specific goals will vary from one implementation to another and from one developer to another. Further, in the disclosed embodiments below, the term “or” may be used to describe different features of particular embodiments. Use of the term “or” is intended to be interpreted both as inclusive and exclusive, thus combinations may include any or all of the identified features as described herein.

Illustrative System for Minimally Invasive Surgical Tools with Haptic Feedback

In one illustrative system for minimally invasive surgical tools with haptic feedback, the system is configured to assist a surgeon during minimally invasive surgery (MIS) on a live patient. For example, a surgeon may perform a MIS to perform cardio electrophysiology to measure changes in electric potentials (i.e. voltages) on the inside surface of a patient's heart, such as following a heart attack, to detect any abnormalities or to ablate heart tissue to address arrhythmias.

Referring now to FIG. 1, FIG. 1 shows an illustrative embodiment of a system 10 for minimally invasive surgical tools with haptic feedback according to one embodiment of the present invention. The system 10 in FIG. 1 comprises an insertion sheath 20, a surgical tool 30 (a guide wire, in this case) with a handle 32, a computer 50 with a processor 52, memory 54 and a display 56, and a heart rate monitor 60.

To perform the illustrative MIS procedure, the surgeon makes an incision in the patient's leg 12 and inserts an insertion sheath 20, in this case a catheter, into the patient's femoral artery to provide an insertion path for a surgical tool. The surgeon then inserts the catheter 20 through the patient's vascular system until it reaches the patient's heart. The surgeon may then insert a surgical tool 30, such as a guide wire equipped with a voltage sensor 36 or sensors on the distal end of the guide wire 30 through the catheter 20 to the patient's heart to measure voltages at various points on or within the heart's walls. Such a guide wire 30 typically has a proximal end that is connected to a handle 32 to allow the surgeon to maneuver the guide wire 30 to reach various points of interest on the heart's wall. To maneuver the guide wire 30, the surgeon manipulates one or more manipulanda 34, e.g. knobs or levers, on the guide wire's handle 32 to move the distal tip of the guide wire 30 in any of a number of directions. In such an embodiment, the surgeon may then maneuver the guide wire's distal tip to contact the heart's wall to take voltage measurements with the sensor(s) 36.

In the illustrative embodiment shown in FIG. 1, the insertion tube 30 has been equipped with an actuator 40 to assist the surgeon in performing the MIS procedure. An inductive actuator 40 configured in a ring or cylindrical shape has been coupled to the proximal end of the insertion tube 20 such that the guide wire 30 passes through the actuator 40 into the insertion tube 30. The inductive actuator 40 can be actuated by transmitting an electrical current through the coils of the actuator 40 to generate electromagnetic forces on the guide wire 30 to provide kinesthetic haptic effects to assist or resist translational movement of the guide wire 30 within the insertion tube. An advantage of using an inductive actuator may be that, because there is no physical coupling between the actuator and the guide wire as there might be when using a roller, a surgeon manipulating the guide wire may receive more accurate tactile sensations because there is no friction and inertia to overcome as may be the case were rollers or other frictional contact employed. However, other types of actuators may be employed as will be discussed in more detail below.

In addition, the handle 32 of the guide wire 30 includes a plurality of actuators 42, 44. One of the actuators 42 is a vibrotactile actuator and is used to output vibrational effects to the guide wire handle 32 based on the voltages sensed by the sensor(s) 36 on the distal end of the guide wire. For example, the frequency of a vibration effect may be proportional to the magnitude of the voltage sensed by the sensor(s) 36, thus providing the surgeon with additional information regarding the status of the procedure. The vibrational infor-

mation in this case is in addition to a display showing graphical information about the various sensor readings.

The second actuator 44 disposed within the handle 32 is configured to provide haptic effects to the manipulandum 34 on the handle. For example, the second actuator 44 may output haptic effects based on a contact force between the distal tip of the guide wire and the wall of the heart, or based on an angle of attack of the distal tip of the guide wire and the wall of the heart. In the embodiment shown, the second actuator 44 outputs a kinesthetic force to resist movement of the manipulandum 34 based on a sensed force on the tip of the distal end of the guide wire (force sensor not shown).

The computer 50, which comprises a processor 52 and a memory 54, receives sensor signals from the surgical tool 30 and, in some instances, the insertion sheath 20, and generates actuator signals to cause haptic effects to be output by the various actuators 40, 42, 44 on the guide wire 30, the guide wire handle 32 or manipulandum 34. In addition, the computer 50 receives information from other external devices, such as the heart monitor 60, which it may use as well to generate haptic effects. Examples of other external sensors include heart rate monitors, blood pressure monitors, oxygen sensors, blood gas sensors, etc.

For example, in this illustrative embodiment, heart rate monitor 60 is connected to the patient and provides heart rate information to the computer 50. The computer 50 can generate haptic effects to indicate if the patient's heart rate falls outside of acceptable limits. Because the surgeon may be focused on the particular voltage readings and manipulating the guide wire, this additional information may not be immediately apparent to the surgeon. For example, if the patient's heart begins beating too rapidly, the computer 50 can generate an actuator signal to cause a haptic effect to indicate a potentially dangerous condition and bring the abnormal heart rate to the surgeon's attention.

In addition, the computer 50 can output display signals to cause the display 56 to display relevant information to the surgeon, such as visual indications of sensed voltages, images from a camera inserted into the catheter, heart rate, etc. Thus, the system 10 can provide an immersive, integrated experience that allows the surgeon to focus on the MIS procedure, while receiving a variety of inputs that provide immediate tactile responses to the surgeon to allow her to better perform the procedure and monitor conditions that might otherwise divert her attention.

Referring now to FIG. 2a, FIG. 2a shows a system 100 for minimally invasive surgical tools according to one embodiment of the present invention. System 100 comprises an insertion sheath 110, a first surgical tool 120, and a second surgical tool 130. Insertion sheath 110 comprises a plurality of rollers 112a,b and a plurality of actuators 140a,b, each coupled to one of the plurality of rollers 112a,b. Insertion sheath 110 is configured to be partially inserted into the patient's body 102 and to receive a surgical tool, such as surgical tool 120. In the embodiment shown, the insertion sheath 110 comprises a trocar.

In the embodiment shown, rollers 112a,b are configured to contact surgical tool 120 and are configured to output haptic forces created by the actuation of actuators 140a,b, respectively. In one embodiment, each of actuators 140a,b is an active actuator and is configured to cause its respective roller 112a,b to rotate. By rotating the respective rollers, actuators 140a,b can output kinesthetic forces configured to assist or resist translational movement of surgical tool 120 within the insertion sheath 110. For example, in the embodiment shown, actuators 140a,b comprise DC motors but could also include passive actuators (i.e. magnetic brakes), cams or other friction

producing or modulating means. In some embodiments, however, actuators **140a,b** comprise passive actuators configured to brake their respective roller **112a,b** to resist translational movement of the surgical tool **120** within the insertion sheath **110**. In some embodiments, one or both rollers **112a,b** are coupled to sensors, such as rotational encoders, that are configured to detect a rotation of the roller **112a,b**. In one such embodiment, the sensors are configured to transmit a sensor signal to a processor to indicate a movement or position of the roller based on a corresponding movement of the surgical tool **120**.

In some embodiments, the trocar **110** is configured to be sterilized between MIS procedures, though in some embodiments, trocar **110** is configured to be discarded. Because rollers **112a,b** are configured to contact surgical tool **120**, they are either configured to be discarded or sterilized between MIS procedures. In some embodiments, rollers **112a,b** and actuators **140a,b** may be disposed within a subassembly that is configured to be releasably coupled to the insertion sheath **110** such that the insertion sheath **110** and the roller/actuator subassembly can be decoupled following a MIS procedure and each can be individually sterilized or discarded.

In addition to actuators **140a,b**, insertion sheath **110** also comprises vibrotactile actuator **140c**, which is configured to apply vibrotactile haptic effects to the surgical tool **120** or the insertion sheath **110**. In the embodiment shown, actuator **140c** comprises a piezoelectric actuator, though in other embodiments, other types of actuators may be employed, such as eccentric rotating masses, linear resonant actuators, voice coils, or other suitable actuators. In addition, a plurality of vibrotactile actuators may be incorporated into the sheath, or, in some embodiments, no vibrotactile actuators may be employed.

In the embodiment shown, surgical tool **120** comprises a catheter and thus may be both a surgical tool and an insertion sheath. Surgical tool **120** is configured to be inserted into insertion sheath **110** and to be inserted into a patient's body **102**. In the embodiment shown, surgical tool **120** comprises at least one sensor **152** coupled to the distal end of the surgical tool. The sensor **152** comprises a force sensor and is configured to sense a contact force between the distal end of the surgical tool **120** and an obstacle, such as a stenosis or an internal organ. The sensor **152** is configured to generate a sensor signal indicating a magnitude of the sensed force and to transmit the sensor signal to a processor (not shown), which may use the sensor signal to actuate one or more actuators **140a,b** coupled to the insertion sheath. For example, the actuators may generate a force to resist further insertion of the surgical tool, such as to amplify a sensed force on a distal tip of the surgical tool **120**. In some embodiments, the processor may generate a signal to cause the actuators **140a,b** to completely resist or prevent further insertion of the surgical tool **120**, or to reverse the motion of the surgical tool to withdraw the surgical tool **120**. One such embodiment may be advantageous as it may prevent a surgeon from inadvertently puncturing an internal organ or a blood vessel within a patient.

In some embodiments, other types of sensors **152** may be affixed to the distal tip of the surgical tool **120**, such as voltage sensors, temperature sensors, fluid flow sensors, or viscosity sensors. In some embodiments, one or more sensors may be affixed to other portions of the surgical tool **120** or inserted into the surgical tool **120**. For example, a sensor (or sensors) may be inserted into surgical tool **120**, such as a fiber optic sensor, fluoroscope, or video camera to provide sensor signals to a processor. In some embodiments, one or more sensors may be arrayed within the surgical tool **120**, such as to sense a position of a further surgical tool **130** inserted within sur-

gical tool **120** or the amount of bend within a surgical tool. For example, in some MIS procedures, a surgeon may navigate through a tortuous portion of the vascular system, such as in a patient's brain, and may need an indication of much the surgical tool is bending during performance of the procedure. If too much bending is sensed, a processor may generate a haptic effect based on the sensed amount of bend and output a haptic effect to the surgical tool or handle. In some embodiments, a system **100** may comprise non-colocated sensors configured to detect a distance between the sensors, a change in resistance or voltage between the sensors, or other differences in status between the two sensors to generate a sensor signal. In one such an embodiment, the distal end of a surgical tool **120**, **130** may comprise a first sensor and the insertion sheath **110**, **120** may comprise a second sensor. A processor may detect a difference in sensor readings between the two sensors and generate an actuator signal based on the difference. In one embodiment, the sensors may be configured to detect a distance between the sensors and generate one or more sensor signals and transmit the sensor signals to a processor.

Surgical tool **120** may also comprise an actuator **142** coupled to the surgical tool **120**. In the embodiment shown, the actuator **142** is releasably coupled to the surgical tool **120**, though in some embodiments the actuator **142** may be permanently coupled to, or integrally disposed within, the surgical tool. In this embodiment, actuator **142** comprises an inductive actuator and is configured to provide haptic effects to surgical tools, such as surgical tool **130**, that have been inserted within surgical tool **120**. As discussed above, surgical tool **120** comprises a catheter and thus is configured to allow one or more surgical tools to be inserted within surgical tool **120**. For example, in the embodiment shown in FIG. **2a**, surgical tool **130** comprises a guide wire and is configured to be inserted within catheter **120**. In such an embodiment, actuator **142** is configured to generate electromagnetic forces to resist or assist translational movement of the guide wire **130** within the catheter. In other embodiments, surgical tool **130** may comprise other suitable surgical tools, such as a deflectable catheter or an electrophysiology probe. As discussed above, inductive actuators may provide advantages in such MIS procedures because they do not require a surgeon to overcome friction or inertia of a roller or other physical coupling to move guide wire **130** within surgical tool **120**. However, in some embodiments, other types of actuators may be used, such as one or more rollers.

For example, FIG. **2b** shows a system for minimally invasive surgical tools with haptic feedback in which surgical tool **120** is coupled to an actuator **143** which comprises a plurality of rollers **145a,b** at least partially disposed within actuator **143**. Each roller **145a,b** is in communication with an actuator **146a,b**, which are configured to impart forces on surgical tool **130** by rotating rollers **145a,b** or resisting rotation of roller **145a,b**, thereby assisting or resisting translational movement of surgical tool **130** within surgical tool **120**. As discussed above with respect to insertion sheath **110**, actuators **145a,b** may comprise active or passive actuators, or in some embodiments, may comprise one of each or a plurality of different types of actuators. Actuator **143** may be desirable in embodiments in which surgical tool **130** may be adversely affected by the use of an inductive actuator **142** or surgical tool **130** is not susceptible to forces generated by an inductive actuator **142**. Further, as discussed above, actuators **142**, **143** may be used to assist with the insertion of a surgical tool **130** within surgical tool **120** or to resist movement or prevent movement if surgical tool **130** may puncture a patient's organ or blood vessel.

Referring now to FIG. 2c, FIG. 2c shows a system for minimally invasive surgical tools with haptic feedback according to one embodiment of the present invention. The embodiment shown in FIG. 2c is similar to those shown in FIGS. 2a and 2b, however, the insertion sheath 110 comprises actuators 140a-c but does not include the rollers 112a,b. Instead, actuators 140a-c are configured to output haptic effects to the insertion sheath 110 or to the surgical tool 120. For example, in one embodiment, one or more of actuators 140a-c comprise vibrotactile actuators, such as eccentric rotating masses. In one embodiment, one or more of actuators 140a-c comprise resistive actuators configured to resist movement of the surgical tool 120. For example, in one embodiment, actuators 140a,b each comprise a braking surface configured to be moved into contact with the surgical tool 120 to apply a resistive force on the surgical tool. In one embodiment, one or more of actuators 140a-c may comprise an inductive actuator configured to exert a force on the surgical tool. In a further embodiment, one or more of actuators 140a-c may be configured to alter the surface friction of the surgical tool to create a resistance to movement of the surgical tool within its insertion sheath or delivery catheter. Thus, while some embodiments shown and discussed herein employ one or more rollers to apply forces to surgical tool 120, other embodiments may be configured to only vibrotactile forces on the insertion sheath 110 or to apply forces to the surgical tool 120 using other mechanisms.

Referring again to FIG. 2a, in the embodiment shown, surgical tool 130 is configured to be inserted within surgical tool 120 and comprises at least one sensor 150 coupled to the surgical tool's 130 distal tip. The proximal end of surgical tool 130 is coupled to a handle 132, which is configured to allow a surgeon or other user to insert or retract the surgical tool 130 within surgical tool 120. In addition, handle 132 comprises one or more manipulanda 134 to manipulate the distal tip of the surgical tool 130. For example, manipulandum 134 may be used to bend the distal tip of the surgical tool 130 away from the longitudinal axis of the surgical tool 130, thereby "steering" the surgical tool in a particular direction. In addition, handle 132 comprises a plurality of actuators configured to output haptic effects to a user of the handle 132.

In the embodiment shown, handle 132 is releasably coupled to surgical tool 130. As previously discussed, MIS surgical tools typically must be sterilized or discarded after being used in an MIS procedure. Thus, in one embodiment handle 132 is configured to be decoupled from surgical tool 132 and discarded after use in an MIS procedure. In another embodiment, handle 132 is configured to be sterilized following an MIS procedure. Further, in some embodiments, handle 132 is permanently coupled to surgical tool 130 and thus may be discarded with surgical tool 130 or sterilized with surgical tool 130.

Actuator 146 comprises a vibrotactile actuator configured to output a vibrational or vibrotactile effect to the handle 132. For example, in the embodiment shown, actuator 146 comprises an eccentric rotating mass (ERM) coupled to a rotary motor. In some embodiments, other types of actuators may be employed, such as piezoelectric actuators, voice coils, or linear resonant actuators (LRAs). In some embodiments, a plurality of vibrotactile actuators may be disposed within the handle 132, while in other embodiments, no vibrotactile actuators may be used.

The vibrotactile actuator 146 may be employed to provide information associated with the MIS procedure to a surgeon or user of the handle 132. For example, in the illustrative embodiment discussed previously, the distal tip of a surgical tool 130 may be coupled to a voltage sensor 150 which

provides sensor signals to a processor indicating sensed voltages on a patient's heart. The processor may then generate actuator signals to cause the vibrotactile actuator 146 to output a vibration to the handle 132 based at least in part on the sensed voltage. In one embodiment, the distal tip of the surgical tool 130 may also, or instead, be fitted with a force sensor 150 which provides a sensor signal comprising force information to the processor, which generates actuator signals to generate vibrational haptic effects proportional in magnitude to the force sensed by the sensor 150. Such an embodiment may provide additional information to a surgeon beyond the information provided by other actuators in the system 100, such as actuator 142 or 143.

While actuators 142, 143 may resist movement of the surgical tool, vibrational effects provided by actuators 146 may provide an indication of the magnitude of the force applied by the tool on an obstacle that may be useful in combination with resistances generated by other actuators 142, 143. Still further information may be output by actuator 146. For example, external sensors may transmit sensor signals to a processor, which may generate actuator signals to actuator 146 to cause it to output a vibrational effect to the handle 132 to apprise a surgeon of another condition that is not related to forces or sensor readings from the surgical tool. For example, external sensors may include heart monitors, blood pressure monitors, blood oxygen monitors, or other sensors monitoring a patient's status.

In addition to, or instead of, vibrotactile actuator 146, handle 132 may comprise actuator 144, which is configured to output kinesthetic forces to manipulandum 134. In the embodiment shown, the actuator is configured to output a force to resist or assist the movement of manipulandum 134. For example, a processor in communication with the surgical tool 130 may detect that further movement of the distal tip of surgical tool 130 is applying too much pressure to a patient's blood vessel or internal organ and generate an actuator signal to cause the actuator 144 to resist movement of the manipulandum 134. In one embodiment, surgical tool 130 may comprise a sensor 150 that detects an angle of attack of the distal tip of the surgical tool as it approaches or contacts an obstruction within a patient. For example, if an angle of attack of the distal tip is too shallow, a second sensor coupled to the tip of the surgical tool 130 may be unable to accurately sense a condition within a patient, or, in a procedure where a puncture must be made (e.g. a trans-septal puncture), if the angle of attack is too shallow, the tool may puncture the organ and exit the organ in the wrong location. In such an embodiment, the actuator 144 may output a force to prevent further movement of the manipulandum 134. In addition, actuator 142, 143 may output a force to prevent further insertion of the surgical tool 130. In some embodiments, actuator 144 may be configured to output a vibrational effect, such as to indicate that the angle of attack is too shallow or that a dangerous amount of pressure is being exerted by the distal tip of the surgical tool 130, rather than a resistive force.

Referring now to FIG. 3, FIG. 3 shows a system 200 for minimally invasive surgical tools with haptic feedback according to one embodiment of the present invention. The system 200 shown in FIG. 3 comprises the embodiment shown in FIG. 2a coupled to a power supply 210 and trigger 212 for a therapeutic surgical tool 130a. In the embodiment shown in FIG. 3, surgical tool 130a comprises an ablation tool 150a coupled to the distal tip of the surgical tool 130a in addition to sensor(s) 150. The ablation tool 150a is configured to receive power signals from the power supply 210 and to ablate tissue contacted by the ablation tool 150.

Power supply **210** comprises a trigger **212** and an actuator **240** and is configured to supply power signals, such as electric current or electric voltage, to the surgical tool **130a** and ablation tool **150a**. The trigger **212** is used by an operator, such as a surgeon, to apply power to the ablation tool **150a** and may comprise a pressure sensitive switch, a slider control, a knob, an on/off switch, or other trigger mechanism. In one embodiment, as more pressure is applied to the trigger **212**, more power may be transmitted to the ablation tool **150a**. Actuator **240** is configured to output a force to the trigger **212** to provide feedback to the operator to indicate whether too much power is applied or whether too much tissue may have been ablated. For example, in one embodiment, actuator **240** comprises an electromagnetic actuator configured to output a force to resist depression of the trigger **212**. As tissue is ablated, a processor (not shown) may determine the quantity of tissue ablated based on a sensor or calculations made using pre-defined characteristics of a patient. The processor may then generate actuator signals and transmit the actuator signals to cause the electromagnetic actuator to resist depression of the trigger **212** and may cause the trigger to be opened to reduce or halt the flow of power to the ablation tool **150a**. Further, a second actuator (not shown) may be in communication with the trigger **212** to output a vibrotactile effect to the trigger **212** to indicate a warning to the operator in addition to the resistance generated by the first actuator **240**. Such an indication may be advantageous as it may provide confirmation to the surgeon of an error condition rather than just a sticky power trigger. In a further embodiment, actuator **146** may be actuated to output a vibrational effect as tissue is ablated. In still a further embodiment, actuator **144** may be an actuator to resist further movement of the distal tip of the surgical tool **130a** towards additional tissue within the patient, thus providing multiple channels of haptic input to the operator: resistance to the trigger **212**, vibrational effects on the trigger **212**, vibrational effects on the handle **132** and resistance to movement of the distal tip of the surgical tool **130a**. Such varied haptic effects may provide more meaningful feedback to a surgeon and help prevent inadvertent injury to a patient.

Referring now to FIG. **4a**, FIG. **4a** shows a system **300** for minimally invasive surgical tools with haptic feedback according to embodiments of the present invention. In the embodiment shown in FIG. **4a**, the system **300** comprises the system **200** shown in FIG. **3** in communication with a computer **350** comprising a processor **352** and a memory **354**. The system **300** further comprises an external sensor **360** in communication with the computer **350**. Computer **350** is configured to receive sensor signals from the various sensors **150**, **152** located within system **200** and to generate actuator signals to be transmitted to one or more of the actuators (e.g. **140a-c**, **142**, **144**, **146**, **240**) in the system **200**. In addition, computer **350** is configured to generate and transmit display signals to display **356** to provide information to a surgeon or other operator of the system **300**.

Note that while the embodiment shown in FIG. **4a** comprises the system **200** shown in FIG. **3**, other systems according to some embodiments of the present invention may be coupled to the computer **350**, such as those shown in any of FIGS. **1-3**. FIG. **4b** shows one such alternate embodiment in which a system **400** comprises a system having components arranged as shown in FIG. **1**, as well as a power supply **210** with a manipulandum **212** and an actuator **240** as shown in FIG. **3**.

Processor **352** is configured to execute program code stored in a computer-readable medium to receive sensor information and to generate haptic effects associated with the

MIS procedure being performed. Embodiments of various types of processors and computer-readable media are disclosed below. Reference is made now to the method **500** shown in FIG. **5**, which, in one embodiment, is implemented by programming code stored in memory **354** and executed by the processor **352** shown in FIGS. **4a-b**.

In the embodiment shown in FIG. **5**, the method **500** begins at block **510** where the processor **352** receives a sensor signal from a sensor, such as sensor **150**. In the embodiment shown, sensor **150** comprises a sensor configured to detect an angle of attack of the distal tip of surgical tool **130a** when it contacts an obstacle. The sensor signal comprises information associated with the sensed angle of attack. In one embodiment, the processor **352** may receive a plurality of sensor signals from one or more sensors. For example, surgical tool **130a** may comprise a plurality of sensors, such as an angle of attack sensor and a force sensor such that the processor **352** receives a sensor signal from each of the sensors, or receives multiple sensor signals from one or more of the sensors.

Other sensors within the system **200** may also transmit sensor signals to the processor. For example, sensor **152** on the distal end of the catheter may transmit a sensor signal that is received by the processor. In addition, as discussed previously, rollers **112a,b** may be coupled to, or may comprise, rotational encoders that sense a rotation or position of the rollers **112a,b** and transmit a sensor signal to the processor indicating the position or movement of the rollers **112a,b**. Processor **352** then receives such sensor signals. Additionally, as shown in FIG. **4a**, computer **350** is configured to receive signals from external sensor **360**, which comprises a heart rate monitor in the embodiment shown. After receiving a sensor signal, the method **500** proceeds to block **520**.

At block **520**, the processor **352** determines a status condition associated with the received sensor signal. For example, if the processor **352** receives a sensor signal from a force sensor, the processor **352** may determine a force associated with the sensor signal and compare the force with a threshold. For example, the processor **352** may determine that a force exceeds a first pre-determined threshold and thus a minor danger exists of puncturing tissue within the patient. Or the processor **352** may determine that the force exceeds a higher threshold and thus a serious or critical danger exists of puncturing tissue within the patient. In one embodiment for performing an ablation procedure, it may be desirable to maintain a relatively constant pressure between the ablation tool **150a** and a patient's tissue. In such an embodiment, the processor **352** may apply an assistive force to increase a force between the ablation tool **150a** and the tissue if the sensed pressure falls below a lower threshold or apply a resistive force, or withdraw the surgical tool **130a**, if the pressure exceeds an upper threshold of sensed force.

In another embodiment, the processor **352** may receive a sensor signal indicating a voltage on the surface of an internal organ. The processor may then compare the voltage to one or more voltage thresholds. Alternatively, the processor **352** may simply store the voltage for later use. Still other types of sensors may result in different types of sensor signals to be received by the processor **352**, such as fluid flows, viscosities, pressures, or temperatures associated with conditions present within the patient. Other sensors, such as positional sensors or other sensors located within the insertion sheath or surgical tool (e.g. a catheter) may also transmit sensor signals that are received by the processor **352**.

For example, in one embodiment, catheter **120** may comprise a sensor **152** that is configured to detect when a surgical tool **130a** has reached the distal end of the catheter **120**. In such an embodiment, the processor **352** may receive a sensor

signal from the sensor 152 when the surgical tool 130a reaches the sensor 152 and the processor 352 determines that the surgical tool 130a has been fully inserted into the catheter. Alternatively, the processor 352 may receive a sensor signal from the sensor 150 indicating that the surgical tool 130a has not reached the distal end of the catheter. In such an embodiment, the processor 352 may be controlling an actuator, such as actuator 143, to automatically insert the surgical tool 130a into the catheter 120. Thus, the processor 352 determines that the surgical tool has not yet reached the distal end of the catheter. After determining a status condition associated with the sensor signal, the method proceeds to block 530.

At block 530, the processor 352 generates an actuator signal based at least in part on the sensor signal or the status condition. For example, as discussed above, the processor 352 determined a status condition associated with a sensed force between the surgical tool 130a and an obstacle. In such an embodiment, the processor 352 generates an actuator signal configured to increase a resistance to movement of the surgical tool such that the rolling resistance of the rollers 112a,b may be varied to provide an amplification of the actual force being applied by surgical tool 130 to allow increased precision. For example, the processor 352 may generate an actuator signal to be transmitted to actuator 142 or 143 to generate a force opposing further movement of the surgical tool 130a into surgical tool 120. In a related embodiment, if the processor 352 has determined that a dangerous amount of pressure is being applied, the processor 352 may generate an actuator signal configured to prevent further movement of the surgical tool 130a into surgical tool 120 or to reverse movement of the surgical tool 130a and to withdraw the surgical tool 130a until the sensed force falls below a threshold. Such an embodiment may be advantageous as it may prevent inadvertent injury to a patient.

In a related embodiment, the processor 352 may receive a sensor signal indicating a status associated with manipulandum 134 or power supply 210. For example, in one embodiment, the surgical tool may comprise a manipulandum configured to control the surgical tool. In such an embodiment, the surgical tool 130 or other part of the system 200 may comprise sensors that provide sensor signals associated with the manipulation of the surgical tool, such as force sensors, angle of attack sensors, etc. Processor 352 may receive such sensor signals and generate actuator signals configured to cause an actuator, such as actuator 144, to apply a haptic effect to the manipulandum, such as to assist or resist movement of the manipulandum or to provide a vibrotactile effect to the manipulandum 134.

For example, as discussed above, during an ablation process, once the distal tip of the surgical tool 130a is in place, the actuated rollers 112a,b could be used to generate an actuator signal to ensure a required force on the tissue is maintained. The actuator signal can be configured to force the distal tip of the surgical tool 130 into contact with the tissue within a pre-determined range such as by either applying pressure in addition to pressure applied by the surgeon or by resisting further pressure or retracting to surgical tool 130a. A similar control method could also be utilized in a trans-septal puncture. Once the surgical tool 130 is in place to perform the puncture, the actuated rollers 112a,b could be used to perform a very controlled puncture using a controlled level of pressure to cause the puncture.

In one embodiment, the processor 352 may generate an actuator signal based on a non-tactile sensed condition. For example, a sensor may be configured to sense conditions that are not forces, such as voltages, etc. In such an embodiment, the processor 352 may generate a haptic effect based on such

a sensed condition. In one embodiment, a surgeon performs a MIS procedure to measure voltages occurring on a patient's heart. In such an embodiment, the processor 352 may generate an actuator signal based at least in part on a magnitude of a sensed voltage, a fluctuation of a sensed voltage, or whether the voltage is above or below a threshold. In one such embodiment, the processor may generate an actuator signal to cause an actuator to output a vibrotactile effect. For example, the processor 352 may generate an actuator signal to cause actuator 146 to output a vibrotactile effect based at least in part on a sensed voltage such that the frequency or magnitude of the vibrational effect is proportional to the magnitude of the voltage. Thus, for a relatively high voltage, the processor 352 may generate an actuator signal having a relatively high frequency. Conversely, for a relatively low voltage, the processor 352 may generate an actuator signal having a relatively low frequency.

In a further embodiment, processor 352 may generate an actuator signal based on sensor information or a status condition determined from an external sensor 360. For example, the processor 352 may receive a measured heart rate or blood pressure from the external sensor 360 and determine that the heart rate has fallen below a threshold. In one embodiment, the processor 352 generates an actuator signal configured to cause an actuator 146 to output a vibrotactile effect to the handle 132 of the surgical tool 130, wherein the vibrotactile effect is configured to indicate a warning condition associated with the external sensor. For example, the actuator signal may be configured to cause an actuator, e.g. actuator 146, output a series of pulsed vibrations to simulate a heartbeat to indicate a warning condition associated with the patient's heart rate or blood pressure. In such an embodiment, the magnitude of the vibrations may be proportional to the amount the sensed condition exceeds the threshold. After generating an actuator signal, the method 500 proceeds to block 540

In block 540, the processor 352 transmits the generated actuator signal to an actuator. For example, if the processor 352 has generated an actuator signal to cause a vibrotactile effect to the handle 132 of the surgical tool, the processor 352 transmits the actuator signal to actuator 146. In some embodiments the processor 352 may transmit the actuator signal to a plurality of actuators, or may modify an actuator signal before transmitting the actuator signal. For example, in one embodiment, the processor 352 generates an actuator signal configured to cause actuators 140a,b to rotate rollers 112a,b to resist further insertion of the surgical tool 120 into the insertion sheath 110. However, because the rollers are located on opposite sides of the surgical tool 120, they must rotate in opposite directions to generate the resistive force. Thus, the processor 352 may generate one actuator signal suitable to resist movement of the surgical tool 120 and transmit the actuator signal to actuator 140a but invert the actuator signal before transmit it to actuator 140b.

In a further embodiment, a surgeon may be performing an ablation procedure. During the procedure, the processor 352 may determine that too much tissue is being ablated and may generate an actuator signal to both resist movement of the trigger 212 on the power supply 210 as well as resist movement of the manipulandum 134 that controls movement of the surgical tool 130a performing the ablation. Such effects may provide an indication that further power should not be applied and that the distal tip of the tool should not be further moved towards the tissue being ablated. The processor 352 may generate one actuator signal suitable for both actuators and perform post-processing before transmitting the actuator signal, such as changing a magnitude, to each of the actuators 144, 240. After transmitting the actuator signal to the actuator,

the method 500 returns to step 510 to receive another sensor signal or to step 520 to determine another status condition associated with the MIS procedure.

The method 500 shown in FIG. 5 is illustrative of one method according to some disclosed embodiments of the present invention and is not intended to limit the scope of the disclosure. Further, while the steps of the method 500 have been set forth in a particular order, there is no requirement that the steps be performed in such an order or that all of the steps shown in FIG. 5 be performed. For example, block 530 may be performed independently of whether a sensor signal is received, such as for actuator signals indicating a passage of time or other independent event. Further, a status condition need not be determined prior to generating an actuator signal or even at all.

While the methods and systems herein are described in terms of software executing on various machines, the methods and systems may also be implemented as specifically-configured hardware, such as a field-programmable gate array (FPGA) specifically to execute the various methods. For example, referring again to FIGS. 1 and 2, embodiments can be implemented in digital electronic circuitry, or in computer hardware, firmware, software, or in combination of them. In one embodiment, a computer may comprise a processor or processors. The processor comprises a computer-readable medium, such as a random access memory (RAM) coupled to the processor. The processor executes computer-executable program instructions stored in memory, such as executing one or more computer programs for editing an image. Such processors may comprise a microprocessor, a digital signal processor (DSP), an application-specific integrated circuit (ASIC), field programmable gate arrays (FPGAs), and state machines. Such processors may further comprise programmable electronic devices such as PLCs, programmable interrupt controllers (PICs), programmable logic devices (PLDs), programmable read-only memories (PROMs), electronically programmable read-only memories (EPROMs or EEPROMs), or other similar devices.

Such processors may comprise, or may be in communication with, media, for example computer-readable media, that may store instructions that, when executed by the processor, can cause the processor to perform the steps described herein as carried out, or assisted, by a processor. Embodiments of computer-readable media may comprise, but are not limited to, an electronic, optical, magnetic, or other storage device capable of providing a processor, such as the processor in a web server, with computer-readable instructions. Other examples of media comprise, but are not limited to, a floppy disk, CD-ROM, magnetic disk, memory chip, ROM, RAM, ASIC, configured processor, all optical media, all magnetic tape or other magnetic media, or any other medium from which a computer processor can read. The processor, and the processing, described may be in one or more structures, and may be dispersed through one or more structures. The processor may comprise code for carrying out one or more of the methods (or parts of methods) described herein.

The foregoing description of some embodiments of the invention has been presented only for the purpose of illustration and description and is not intended to be exhaustive or to limit the invention to the precise forms disclosed. Numerous modifications and adaptations thereof will be apparent to those skilled in the art without departing from the spirit and scope of the invention.

Reference herein to “one embodiment” or “an embodiment” means that a particular feature, structure, operation, or other characteristic described in connection with the embodiment may be included in at least one implementation of the

invention. The invention is not restricted to the particular embodiments described as such. The appearance of the phrase “in one embodiment” or “in an embodiment” in various places in the specification does not necessarily refer to the same embodiment. Any particular feature, structure, operation, or other characteristic described in this specification in relation to “one embodiment” may be combined with other features, structures, operations, or other characteristics described in respect of any other embodiment.

That which is claimed is:

1. A system comprising:

a surgical tool;

an insertion sheath configured to be partially inserted within a patient’s body and to receive the surgical tool; a first actuator coupled to the insertion sheath, the first actuator configured to receive a first actuator signal and, responsive to the first actuator signal, output a haptic effect to the insertion sheath;

a second actuator and a roller coupled to the insertion sheath, the roller configured to contact the surgical tool and to translate the surgical tool through the insertion sheath;

a sensor configured to be positioned externally in relation to the patient’s body and to detect a physiological status of the patient, the sensor being separate from the surgical tool; and

a processor in communication with the first actuator, the second actuator, and the sensor, the processor configured to:

receive a sensor signal from the sensor, the sensor signal indicating a warning condition associated with the physiological status of the patient;

generate a second actuator signal based on the sensor signal; and

transmit the second actuator signal to the second actuator, the second actuator signal configured to cause the second actuator to rotate the roller to translate the surgical tool through the insertion sheath.

2. The system of claim 1, further comprising:

a second sensor coupled to a distal end of the surgical tool and configured to generate a second sensor signal.

3. The system of claim 2, wherein the processor is in communication with the second sensor and configured to:

receive the second sensor signal;

generate the second actuator signal based in part on the second sensor signal; and

transmit the second actuator signal to the second actuator.

4. The system of claim 2, wherein the second sensor is configured to detect a force.

5. The system of claim 4, wherein the second sensor signal comprises a sensed force associated with a contact force between the surgical tool and an obstacle, and wherein the second actuator is configured to output a force configured to maintain the contact force between a first threshold and a second threshold.

6. The system of claim 2, wherein the second sensor is configured to detect a fluid flow or a viscosity.

7. The system of claim 2, wherein the surgical tool comprises:

a handle configured to be manipulated;

a third actuator coupled to the handle, the third actuator configured to output a third haptic effect to the handle in response to a third actuator signal.

8. The system of claim 7, wherein the handle comprises a trigger and a fourth actuator, the fourth actuator configured to output a trigger haptic effect to the trigger.

15

9. The system of claim 7, wherein the handle and the third actuator are removably coupled to the surgical tool, the handle configured to be removed and discarded following a surgical procedure.

10. The system of claim 2, wherein the surgical tool comprises:

- a therapeutic surgical tool; and
- a power supply coupled to the therapeutic surgical tool, the power supply configured to control an intensity of a therapeutic effect provided by the therapeutic surgical tool, the power supply comprising:
 - a trigger, and
 - a third actuator coupled to the trigger, the third actuator configured to receive a third actuator signal and to output a trigger haptic effect to the trigger based on the third actuator signal.

11. The system of claim 10, wherein the trigger haptic effect comprises a vibration.

12. The system of claim 10, wherein the trigger haptic effect comprises a kinesthetic force configured to resist movement of the trigger.

13. The system of claim 1, wherein the sensor comprises a blood pressure monitor, an oxygen sensor, or a blood gas sensor.

14. The system of claim 7, wherein the third haptic effect comprises a vibration and is based at least in part on the second sensor signal.

15. The system of claim 1, wherein the second actuator and the roller are positioned within a subassembly that is releasably coupled to the insertion sheath, the subassembly configured to be removed from the insertion sheath following a surgical procedure.

16. The system of claim 1, wherein the first actuator comprises a piezoelectric actuator.

17. The system of claim 2, further comprising a third sensor directly positioned on the insertion sheath, wherein the processor is further configured to:

- receive the second sensor signal from the second sensor, the second sensor signal indicative of a first parameter;
- receive a third sensor signal from the third sensor, the third sensor signal indicative of a second parameter;
- determine a difference between the first parameter and the second parameter; and
- transmit the first actuator signal or the second actuator signal based on the difference between the first parameter and the second parameter.

18. The system of claim 17, wherein the first parameter comprises a first location of the surgical tool, the second parameter comprises a second location of the insertion

16

sheath, and the difference comprises a distance between the first location and the second location.

19. The system of claim 1, wherein the processor is further configured to generate the first actuator signal, the first actuator signal indicating a passage of time.

20. The system of claim 1, further comprising:
a third actuator coupled to the surgical tool and configured to receive a third actuator signal and output a third haptic effect.

21. The system of claim 20, wherein the surgical tool is a first surgical tool that is configured to receive a second surgical tool, the system further comprising:

- the second surgical tool, wherein the second surgical tool comprises a handle; and
- a fourth actuator coupled to the handle of the second surgical tool and configured to receive a fourth actuator signal and output a fourth haptic effect to the handle.

22. The system of claim 21, wherein the handle comprises:
a trigger; and
a fifth actuator configured to output a fifth haptic effect to the trigger.

23. A system, comprising:
a surgical tool;
an insertion sheath configured to be partially inserted within a patient's body, the insertion sheath configured to receive the surgical tool;

a non-contact inductive actuator having a cylindrical shape, the inductive actuator coupled to the insertion sheath and configured to allow the surgical tool to pass through the inductive actuator and to translate the surgical tool through the insertion sheath;

a sensor configured to be positioned externally in relation to the patient's body and to detect a physiological status of the patient, the sensor being separate from the surgical tool; and

a processor in communication with the non-contact inductive actuator and the sensor, the processor configured to:
receive a sensor signal from the sensor, the sensor signal indicating a warning condition associated with the physiological status of the patient;
generate an actuator signal based on the sensor signal; and
transmit the actuator signal to the inductive actuator, the actuator signal configured to cause the inductive actuator to translate the surgical tool through the insertion sheath via electromagnetic induction forces.

24. The system of claim 23, wherein the inductive actuator is configured to translationally assist or resist movement of the surgical tool through the insertion sheath.

* * * * *

专利名称(译)	用于具有触觉反馈的微创手术工具的系统和方法		
公开(公告)号	US9358072	公开(公告)日	2016-06-07
申请号	US13/007251	申请日	2011-01-14
[标]申请(专利权)人(译)	ULLRICH CHRISTOPHER J		
申请(专利权)人(译)	ULLRICH CHRISTOPHER J		
当前申请(专利权)人(译)	Immersion公司		
[标]发明人	ULLRICH CHRISTOPHER J		
发明人	ULLRICH, CHRISTOPHER J.		
IPC分类号	A61M25/01 A61B17/00 A61B5/00 A61B5/0205 A61B5/042		
CPC分类号	A61B34/70 A61B17/00234 A61M25/01 A61B5/0084 A61B5/0205 A61B5/042 A61B2034/301 A61B2090/065 A61M25/0113 A61M25/0116 A61B5/7455 A61B34/30 A61B34/76 A61B34/77		
代理机构(译)	KILPATRICK TOWNSEND & STOCKTON LLP		
优先权	61/295438 2010-01-15 US		
其他公开文献	US20110178508A1		
外部链接	Espacenet USPTO		

摘要(译)

公开了用于具有触觉反馈的微创手术工具的系统和方法。一种公开的系统实施例包括插入护套，该插入护套构成部分地插入患者体内，该插入护套构成接收手术工具；至少部分地设置在所述插入护套内的辊子，所述辊子构成接触插入所述插入护套内的手术工具；和致动器连接到辊子，致动器配置成接收致动器信号并基于致动器信号输出触觉效果。

