



US009192329B2

(12) **United States Patent**
Al-Ali

(10) **Patent No.:** **US 9,192,329 B2**
(45) **Date of Patent:** **Nov. 24, 2015**

(54) **VARIABLE MODE PULSE INDICATOR**

(75) Inventor: **Ammar Al-Ali**, Tustin, CA (US)

(73) Assignee: **MASIMO CORPORATION**, Irvine, CA (US)

(*) Notice: Subject to any disclaimer, the term of this patent is extended or adjusted under 35 U.S.C. 154(b) by 551 days.

5,041,187 A 8/1991 Hink et al.
5,069,213 A 12/1991 Polczynski
5,163,438 A 11/1992 Gordon et al.
5,337,744 A 8/1994 Branigan
5,341,805 A 8/1994 Stavridi et al.
D353,195 S 12/1994 Savage et al.
D353,196 S 12/1994 Savage et al.
5,377,676 A 1/1995 Vari et al.

(Continued)

OTHER PUBLICATIONS

(21) Appl. No.: **11/871,808**

US 8,845,543, 09/2014, Diab et al. (withdrawn)

(22) Filed: **Oct. 12, 2007**

Primary Examiner — Michael D'Angelo
Assistant Examiner — Christian Jang

(65) **Prior Publication Data**

US 2008/0091092 A1 Apr. 17, 2008

(74) *Attorney, Agent, or Firm* — Knobbe, Martens, Olson & Bear LLP

Related U.S. Application Data

(60) Provisional application No. 60/851,861, filed on Oct. 12, 2006.

(51) **Int. Cl.**

A61B 5/02 (2006.01)
A61B 5/1455 (2006.01)
A61B 5/00 (2006.01)
A61B 5/024 (2006.01)

(52) **U.S. Cl.**

CPC *A61B 5/14551* (2013.01); *A61B 5/0002* (2013.01); *A61B 5/6826* (2013.01); *A61B 5/6838* (2013.01); *A61B 5/02438* (2013.01)

(58) **Field of Classification Search**

CPC . A61B 5/024; A61B 5/02416; A61B 5/02438
USPC 600/310, 500
See application file for complete search history.

(56) **References Cited**

U.S. PATENT DOCUMENTS

4,960,128 A 10/1990 Gordon et al.
4,964,408 A 10/1990 Hink et al.

(57) **ABSTRACT**

A user configurable variable mode pulse indicator provides a user the ability to influence outputs indicative of a pulse occurrence at least during distortion, or high-noise events. For example, when configured to provide or trigger pulse indication outputs, a pulse indicator designates the occurrence of each pulse in a pulse oximeter-derived photo-plethysmograph waveform, through waveform analysis or some statistical measure of the pulse rate, such as an averaged pulse rate. When the configured to block outputs or not trigger pulse indication outputs, a pulse indicator disables the output for one or more of an audio or visual pulse occurrence indication. The outputs can be used to initiate an audible tone “beep” or a visual pulse indication on a display, such as a vertical spike on a horizontal trace or a corresponding indication on a bar display. The amplitude output is used to indicate data integrity and corresponding confidence in the computed values of saturation and pulse rate. The amplitude output can vary a characteristic of the pulse indicator, such as beep volume or frequency or the height of the visual display spike.

9 Claims, 9 Drawing Sheets

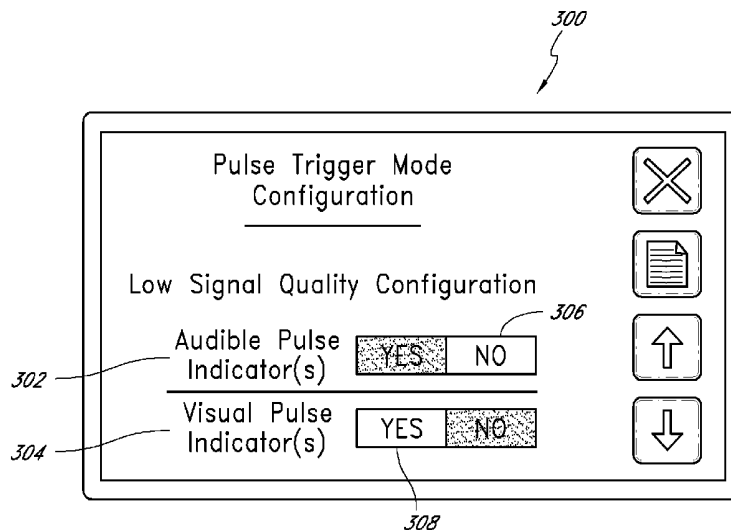

(56)

References Cited

U.S. PATENT DOCUMENTS

D359,546	S	6/1995	Savage et al.	6,397,091	B2	5/2002	Diab et al.
5,431,170	A	7/1995	Mathews	6,430,525	B1	8/2002	Weber et al.
D361,840	S	8/1995	Savage et al.	6,463,311	B1	10/2002	Diab
D362,063	S	9/1995	Savage et al.	6,470,199	B1	10/2002	Kopotic et al.
5,452,717	A	9/1995	Branigan et al.	6,501,975	B2	12/2002	Diab et al.
D363,120	S	10/1995	Savage et al.	6,505,059	B1	1/2003	Kollias et al.
5,456,252	A	10/1995	Vari et al.	6,515,273	B2	2/2003	Al-Ali
5,482,036	A	1/1996	Diab et al.	6,519,487	B1	2/2003	Parker
5,490,505	A	2/1996	Diab et al.	6,525,386	B1	2/2003	Mills et al.
5,494,043	A	2/1996	O'Sullivan et al.	6,526,300	B1	2/2003	Kiani et al.
5,533,511	A	7/1996	Kaspari et al.	6,541,756	B2	4/2003	Schulz et al.
5,561,275	A	10/1996	Savage et al.	6,542,764	B1	4/2003	Al-Ali et al.
5,562,002	A	10/1996	Lalin	6,580,086	B1	6/2003	Schulz et al.
5,590,649	A	1/1997	Caro et al.	6,584,336	B1	6/2003	Ali et al.
5,602,924	A	2/1997	Durand et al.	6,595,316	B2	7/2003	Cybulski et al.
5,632,272	A	5/1997	Diab et al.	6,597,932	B2	7/2003	Tian et al.
5,638,816	A	6/1997	Kiani-Azarbayjany et al.	6,597,933	B2	7/2003	Kiani et al.
5,638,818	A	6/1997	Diab et al.	6,606,511	B1	8/2003	Ali et al.
5,645,440	A	7/1997	Tobler et al.	6,632,181	B2	10/2003	Flaherty et al.
5,685,299	A	11/1997	Diab et al.	6,639,668	B1	10/2003	Trepagnier
D393,830	S	4/1998	Tobler et al.	6,640,116	B2	10/2003	Diab
5,743,262	A	4/1998	Lepper, Jr. et al.	6,643,530	B2	11/2003	Diab et al.
5,758,644	A	6/1998	Diab et al.	6,650,917	B2	11/2003	Diab et al.
5,760,910	A	6/1998	Lepper, Jr. et al.	6,654,624	B2	11/2003	Diab et al.
5,769,785	A	6/1998	Diab et al.	6,658,276	B2	12/2003	Kianl et al.
5,782,757	A	7/1998	Diab et al.	6,661,161	B1	12/2003	Lanzo et al.
5,785,659	A	7/1998	Caro et al.	6,671,531	B2	12/2003	Al-Ali et al.
5,791,347	A	8/1998	Flaherty et al.	6,678,543	B2	1/2004	Diab et al.
5,810,734	A	9/1998	Caro et al.	6,684,090	B2	1/2004	Ali et al.
5,823,950	A	10/1998	Diab et al.	6,684,091	B2	1/2004	Parker
5,830,131	A	11/1998	Caro et al.	6,697,656	B1	2/2004	Al-Ali
5,833,618	A	11/1998	Caro et al.	6,697,657	B1	2/2004	Shehada et al.
5,860,919	A	1/1999	Kiani-Azarbayjany et al.	6,697,658	B2	2/2004	Al-Ali
5,890,929	A	4/1999	Mills et al.	RE38,476	E	3/2004	Diab et al.
5,904,654	A	5/1999	Wohltmann et al.	6,699,194	B1	3/2004	Diab et al.
5,919,134	A	7/1999	Diab	6,714,804	B2	3/2004	Al-Ali et al.
5,934,925	A	8/1999	Tobler et al.	RE38,492	E	4/2004	Diab et al.
5,940,182	A	8/1999	Lepper, Jr. et al.	6,721,582	B2	4/2004	Trepagnier et al.
5,995,855	A	11/1999	Kiani et al.	6,721,585	B1	4/2004	Parker
5,997,343	A	12/1999	Mills et al.	6,725,075	B2	4/2004	Al-Ali
6,002,952	A	12/1999	Diab et al.	6,728,560	B2	4/2004	Kollias et al.
6,011,986	A	1/2000	Diab et al.	6,735,459	B2	5/2004	Parker
6,027,452	A	2/2000	Flaherty et al.	6,745,060	B2	6/2004	Diab et al.
6,036,642	A	3/2000	Diab et al.	6,760,607	B2	7/2004	Al-Ali
6,045,509	A	4/2000	Caro et al.	6,770,028	B1	8/2004	Ali et al.
6,067,462	A	5/2000	Diab et al.	6,771,994	B2	8/2004	Kiani et al.
6,081,735	A	6/2000	Diab et al.	6,792,300	B1	9/2004	Diab et al.
6,088,607	A	7/2000	Diab et al.	6,813,511	B2	11/2004	Diab et al.
6,110,522	A	8/2000	Lepper, Jr. et al.	6,816,741	B2	11/2004	Diab
6,124,597	A	9/2000	Shehada	6,822,564	B2	11/2004	Al-Ali
6,144,868	A	11/2000	Parker	6,826,419	B2	11/2004	Diab et al.
6,151,516	A	11/2000	Kiani-Azarbayjany et al.	6,830,711	B2	12/2004	Mills et al.
6,152,754	A	11/2000	Gerhardt et al.	6,850,787	B2	2/2005	Weber et al.
6,157,850	A	12/2000	Diab et al.	6,850,788	B2	2/2005	Al-Ali
6,165,005	A	12/2000	Mills et al.	6,852,083	B2	2/2005	Caro et al.
6,184,521	B1	2/2001	Coffin, IV et al.	6,861,639	B2	3/2005	Al-Ali
6,206,830	B1	3/2001	Diab et al.	6,898,452	B2	5/2005	Al-Ali et al.
6,229,856	B1	5/2001	Diab et al.	6,920,345	B2	7/2005	Al-Ali et al.
6,232,609	B1	5/2001	Snyder et al.	6,931,268	B1	8/2005	Kiani-Azarbayjany et al.
6,236,872	B1	5/2001	Diab et al.	6,934,570	B2	8/2005	Kiani et al.
6,241,683	B1	6/2001	Macklem et al.	6,939,305	B2	9/2005	Flaherty et al.
6,256,523	B1	7/2001	Diab et al.	6,943,348	B1	9/2005	Coffin, IV
6,263,222	B1	7/2001	Diab et al.	6,950,687	B2	9/2005	Al-Ali
6,278,522	B1	8/2001	Lepper, Jr. et al.	6,961,598	B2	11/2005	Diab
6,280,213	B1	8/2001	Tobler et al.	6,970,792	B1	11/2005	Diab
6,285,896	B1	9/2001	Tobler et al.	6,979,812	B2	12/2005	Al-Ali
6,321,100	B1	11/2001	Parker	6,985,764	B2	1/2006	Mason et al.
6,334,065	B1	12/2001	Al-Ali et al.	6,993,371	B2	1/2006	Kiani et al.
6,343,224	B1	1/2002	Parker	6,996,427	B2	2/2006	Ali et al.
6,349,228	B1	2/2002	Kiani et al.	6,999,904	B2	2/2006	Weber et al.
6,360,114	B1	3/2002	Diab et al.	7,003,338	B2	2/2006	Weber et al.
6,368,283	B1	4/2002	Xu et al.	7,003,339	B2	2/2006	Diab et al.
6,371,921	B1	4/2002	Caro et al.	7,015,451	B2	3/2006	Dalke et al.
6,377,829	B1	4/2002	Al-Ali	7,024,233	B2	4/2006	Ali et al.
6,388,240	B2	5/2002	Schulz et al.	7,027,849	B2	4/2006	Al-Ali
				7,030,749	B2	4/2006	Al-Ali
				7,039,449	B2	5/2006	Al-Ali
				7,041,060	B2	5/2006	Flaherty et al.
				7,044,918	B2	5/2006	Diab

(56)

References Cited

U.S. PATENT DOCUMENTS

7,067,893 B2	6/2006	Mills et al.	7,734,320 B2	6/2010	Al-Ali
7,096,052 B2	8/2006	Mason et al.	7,761,127 B2	7/2010	Al-Ali et al.
7,096,054 B2	8/2006	Abdul-Hafiz et al.	7,761,128 B2	7/2010	Al-Ali et al.
7,132,641 B2	11/2006	Schulz et al.	7,764,982 B2	7/2010	Dalke et al.
7,142,901 B2	11/2006	Kiani et al.	D621,516 S	8/2010	Kiani et al.
7,149,561 B2	12/2006	Diab	7,791,155 B2	9/2010	Diab
7,186,966 B2	3/2007	Al-Ali	7,801,581 B2	9/2010	Diab
7,190,261 B2	3/2007	Al-Ali	7,822,452 B2	10/2010	Schurman et al.
7,215,984 B2	5/2007	Diab	RE41,912 E	11/2010	Parker
7,215,986 B2	5/2007	Diab	7,844,313 B2	11/2010	Kiani et al.
7,221,971 B2	5/2007	Diab	7,844,314 B2	11/2010	Al-Ali
7,225,006 B2	5/2007	Al-Ali et al.	7,844,315 B2	11/2010	Al-Ali
7,225,007 B2	5/2007	Al-Ali	7,865,222 B2	1/2011	Weber et al.
RE39,672 E	6/2007	Shehada et al.	7,873,497 B2	1/2011	Weber et al.
7,239,905 B2	7/2007	Kiani-Azarbayjany et al.	7,880,606 B2	2/2011	Al-Ali
7,245,953 B1	7/2007	Parker	7,880,626 B2	2/2011	Al-Ali et al.
7,254,431 B2	8/2007	Al-Ali	7,891,355 B2	2/2011	Al-Ali et al.
7,254,433 B2	8/2007	Diab et al.	7,894,868 B2	2/2011	Al-Ali et al.
7,254,434 B2	8/2007	Schulz et al.	7,899,507 B2	3/2011	Al-Ali et al.
7,272,425 B2	9/2007	Al-Ali	7,899,518 B2	3/2011	Trepagnier et al.
7,274,955 B2	9/2007	Kiani et al.	7,904,132 B2	3/2011	Weber et al.
D554,263 S	10/2007	Al-Ali	7,909,772 B2	3/2011	Popov et al.
7,280,858 B2	10/2007	Al-Ali et al.	7,910,875 B2	3/2011	Al-Ali
7,289,835 B2	10/2007	Mansfield et al.	7,919,713 B2	4/2011	Al-Ali et al.
7,292,883 B2	11/2007	De Felice et al.	7,937,128 B2	5/2011	Al-Ali
7,295,866 B2	11/2007	Al-Ali	7,937,129 B2	5/2011	Mason et al.
7,328,053 B1	2/2008	Diab et al.	7,937,130 B2	5/2011	Diab et al.
7,332,784 B2	2/2008	Mills et al.	7,941,199 B2	5/2011	Kiani
7,340,287 B2	3/2008	Mason et al.	7,951,086 B2	5/2011	Flaherty et al.
7,341,559 B2	3/2008	Schulz et al.	7,957,780 B2	6/2011	Lamego et al.
7,343,186 B2	3/2008	Lamego et al.	7,962,188 B2	6/2011	Kiani et al.
D566,282 S	4/2008	Al-Ali et al.	7,962,190 B1	6/2011	Diab et al.
7,355,512 B1	4/2008	Al-Ali	7,976,472 B2	7/2011	Kiani
7,356,365 B2	4/2008	Schurman	7,988,637 B2	8/2011	Diab
7,371,981 B2	5/2008	Abdul-Hafiz	7,990,382 B2	8/2011	Kiani
7,373,193 B2	5/2008	Al-Ali et al.	7,991,446 B2	8/2011	Ali et al.
7,373,194 B2	5/2008	Weber et al.	8,000,761 B2	8/2011	Al-Ali
7,376,453 B1	5/2008	Diab et al.	8,008,088 B2	8/2011	Bellott et al.
7,377,794 B2	5/2008	Al-Ali et al.	RE42,753 E	9/2011	Kiani-Azarbayjany et al.
7,377,899 B2	5/2008	Weber et al.	8,019,400 B2	9/2011	Diab et al.
7,383,070 B2	6/2008	Diab et al.	8,028,701 B2	10/2011	Al-Ali et al.
7,415,297 B2	8/2008	Al-Ali et al.	8,029,765 B2	10/2011	Bellott et al.
7,428,432 B2	9/2008	Ali et al.	8,036,727 B2	10/2011	Schurman et al.
7,438,683 B2	10/2008	Al-Ali et al.	8,036,728 B2	10/2011	Diab et al.
7,440,787 B2	10/2008	Diab	8,046,040 B2	10/2011	Ali et al.
7,454,240 B2	11/2008	Diab et al.	8,046,041 B2	10/2011	Diab et al.
7,467,002 B2	12/2008	Weber et al.	8,046,042 B2	10/2011	Diab et al.
7,469,157 B2	12/2008	Diab et al.	8,048,040 B2	11/2011	Kiani
7,471,969 B2	12/2008	Diab et al.	8,050,728 B2	11/2011	Al-Ali et al.
7,471,971 B2	12/2008	Diab et al.	RE43,169 E	2/2012	Parker
7,483,729 B2	1/2009	Al-Ali et al.	8,118,620 B2	2/2012	Al-Ali et al.
7,483,730 B2	1/2009	Diab et al.	8,126,528 B2	2/2012	Diab et al.
7,489,958 B2	2/2009	Diab et al.	8,128,572 B2	3/2012	Diab et al.
7,496,391 B2	2/2009	Diab et al.	8,130,105 B2	3/2012	Al-Ali et al.
7,496,393 B2	2/2009	Diab et al.	8,145,287 B2	3/2012	Diab et al.
D587,657 S	3/2009	Al-Ali et al.	8,150,487 B2	4/2012	Diab et al.
7,499,741 B2	3/2009	Diab et al.	8,175,672 B2	5/2012	Parker
7,499,835 B2	3/2009	Weber et al.	8,180,420 B2	5/2012	Diab et al.
7,500,950 B2	3/2009	Al-Ali et al.	8,182,443 B1	5/2012	Kiani
7,509,154 B2	3/2009	Diab et al.	8,185,180 B2	5/2012	Diab et al.
7,509,494 B2	3/2009	Al-Ali	8,190,223 B2	5/2012	Al-Ali et al.
7,510,849 B2	3/2009	Schurman et al.	8,190,227 B2	5/2012	Diab et al.
7,526,328 B2	4/2009	Diab et al.	8,203,438 B2	6/2012	Kiani et al.
7,530,942 B1	5/2009	Diab	8,203,704 B2	6/2012	Merritt et al.
7,530,949 B2	5/2009	Al-Ali et al.	8,204,566 B2	6/2012	Schurman et al.
7,530,955 B2	5/2009	Diab et al.	8,219,172 B2	7/2012	Schurman et al.
7,563,110 B2	7/2009	Al-Ali et al.	8,224,411 B2	7/2012	Al-Ali et al.
7,596,398 B2	9/2009	Al-Ali et al.	8,228,181 B2	7/2012	Al-Ali
7,618,375 B2	11/2009	Flaherty	8,229,533 B2	7/2012	Diab et al.
D606,659 S	12/2009	Kiani et al.	8,233,955 B2	7/2012	Al-Ali et al.
7,647,083 B2	1/2010	Al-Ali et al.	8,244,325 B2	8/2012	Al-Ali et al.
D609,193 S	2/2010	Al-Ali et al.	8,255,026 B1	8/2012	Al-Ali
D614,305 S	4/2010	Al-Ali et al.	8,255,027 B2	8/2012	Al-Ali et al.
RE41,317 E	5/2010	Parker	8,255,028 B2	8/2012	Al-Ali et al.
7,729,733 B2	6/2010	Al-Ali et al.	8,260,577 B2	9/2012	Weber et al.
			8,265,723 B1	9/2012	McHale et al.
			8,274,360 B2	9/2012	Sampath et al.
			8,301,217 B2	10/2012	Al-Ali et al.
			8,306,596 B2	11/2012	Schurman et al.

(56)

References Cited

U.S. PATENT DOCUMENTS

8,310,336 B2	11/2012	Muhsin et al.	8,706,179 B2	4/2014	Parker
8,315,683 B2	11/2012	Al-Ali et al.	8,712,494 B1	4/2014	MacNeish, III et al.
RE43,860 E	12/2012	Parker	8,715,206 B2	5/2014	Telfort et al.
8,337,403 B2	12/2012	Al-Ali et al.	8,718,735 B2	5/2014	Lamego et al.
8,346,330 B2	1/2013	Lamego	8,718,737 B2	5/2014	Diab et al.
8,353,842 B2	1/2013	Al-Ali et al.	8,718,738 B2	5/2014	Blank et al.
8,355,766 B2	1/2013	MacNeish, III et al.	8,720,249 B2	5/2014	Al-Ali
8,359,080 B2	1/2013	Diab et al.	8,721,541 B2	5/2014	Al-Ali et al.
8,364,223 B2	1/2013	Al-Ali et al.	8,721,542 B2	5/2014	Al-Ali et al.
8,364,226 B2	1/2013	Diab et al.	8,723,677 B1	5/2014	Kiani
8,374,665 B2	2/2013	Lamego	8,740,792 B1	6/2014	Kiani et al.
8,385,995 B2	2/2013	Al-Ali et al.	8,754,776 B2	6/2014	Poeze et al.
8,385,996 B2	2/2013	Smith et al.	8,755,535 B2	6/2014	Telfort et al.
8,388,353 B2	3/2013	Kiani et al.	8,755,856 B2	6/2014	Diab et al.
8,399,822 B2	3/2013	Al-Ali	8,755,872 B1	6/2014	Marinow
8,401,602 B2	3/2013	Kiani	8,761,850 B2	6/2014	Lamego
8,405,608 B2	3/2013	Al-Ali et al.	8,764,671 B2	7/2014	Kiani
8,414,499 B2	4/2013	Al-Ali et al.	8,768,423 B2	7/2014	Shakespeare et al.
8,418,524 B2	4/2013	Al-Ali	8,771,204 B2	7/2014	Telfort et al.
8,423,106 B2	4/2013	Lamego et al.	8,777,634 B2	7/2014	Kiani et al.
8,428,967 B2	4/2013	Olsen et al.	8,781,543 B2	7/2014	Diab et al.
8,430,817 B1	4/2013	Al-Ali et al.	8,781,544 B2	7/2014	Al-Ali et al.
8,437,825 B2	5/2013	Dalvi et al.	8,781,549 B2	7/2014	Al-Ali et al.
8,455,290 B2	6/2013	Siskavich	8,788,003 B2	7/2014	Schurman et al.
8,457,703 B2	6/2013	Al-Ali	8,790,268 B2	7/2014	Al-Ali
8,457,707 B2	6/2013	Kiani	8,801,613 B2	8/2014	Al-Ali et al.
8,463,349 B2	6/2013	Diab et al.	8,821,397 B2	9/2014	Al-Ali et al.
8,466,286 B2	6/2013	Bellott et al.	8,821,415 B2	9/2014	Al-Ali et al.
8,471,713 B2	6/2013	Poeze et al.	8,830,449 B1	9/2014	Lamego et al.
8,473,020 B2	6/2013	Kiani et al.	8,831,700 B2	9/2014	Schurman et al.
8,483,787 B2	7/2013	Al-Ali et al.	8,840,549 B2	9/2014	Al-Ali et al.
8,489,364 B2	7/2013	Weber et al.	8,847,740 B2	9/2014	Kiani et al.
8,498,684 B2	7/2013	Weber et al.	8,849,365 B2	9/2014	Smith et al.
8,504,128 B2	8/2013	Blank et al.	8,852,094 B2	10/2014	Al-Ali et al.
8,509,867 B2	8/2013	Workman et al.	8,852,994 B2	10/2014	Wojtczuk et al.
8,515,509 B2	8/2013	Bruinsma et al.	8,868,147 B2	10/2014	Stippick et al.
8,523,781 B2	9/2013	Al-Ali	8,868,150 B2	10/2014	Al-Ali et al.
8,529,301 B2	9/2013	Al-Ali et al.	8,870,792 B2	10/2014	Al-Ali et al.
8,532,727 B2	9/2013	Ali et al.	8,886,271 B2	11/2014	Kiani et al.
8,532,728 B2	9/2013	Diab et al.	8,888,539 B2	11/2014	Al-Ali et al.
D692,145 S	10/2013	Al-Ali et al.	8,888,708 B2	11/2014	Diab et al.
8,547,209 B2	10/2013	Kiani et al.	8,892,180 B2	11/2014	Weber et al.
8,548,548 B2	10/2013	Al-Ali	8,897,847 B2	11/2014	Al-Ali
8,548,549 B2	10/2013	Schurman et al.	8,909,310 B2	12/2014	Lamego et al.
8,548,550 B2	10/2013	Al-Ali et al.	8,911,377 B2	12/2014	Al-Ali
8,560,032 B2	10/2013	Al-Ali et al.	8,912,909 B2	12/2014	Al-Ali et al.
8,560,034 B1	10/2013	Diab et al.	8,920,317 B2	12/2014	Al-Ali et al.
8,570,167 B2	10/2013	Al-Ali	8,921,699 B2	12/2014	Al-Ali et al.
8,570,503 B2	10/2013	Vo et al.	8,922,382 B2	12/2014	Al-Ali et al.
8,571,617 B2	10/2013	Reichgott et al.	8,929,964 B2	1/2015	Al-Ali et al.
8,571,618 B1	10/2013	Lamego et al.	8,942,777 B2	1/2015	Diab et al.
8,571,619 B2	10/2013	Al-Ali et al.	8,948,834 B2	2/2015	Diab et al.
8,577,431 B2	11/2013	Lamego et al.	8,948,835 B2	2/2015	Diab
8,581,732 B2	11/2013	Al-Ali et al.	8,965,471 B2	2/2015	Lamego
8,584,345 B2	11/2013	Al-Ali et al.	2002/0035315 A1*	3/2002	Ali et al. 600/300
8,588,880 B2	11/2013	Abdul-Hafiz et al.	2002/0038094 A1*	3/2002	Gorman 600/520
8,600,467 B2	12/2013	Al-Ali et al.	2004/0078231 A1*	4/2004	Wilkes et al. 705/2
8,606,342 B2	12/2013	Diab	2009/0247984 A1	10/2009	Lamego et al.
8,626,255 B2	1/2014	Al-Ali et al.	2009/0275844 A1	11/2009	Al-Ali
8,630,691 B2	1/2014	Lamego et al.	2009/0299157 A1	12/2009	Telfort et al.
8,634,889 B2	1/2014	Al-Ali et al.	2010/0004518 A1	1/2010	Vo et al.
8,641,631 B2	2/2014	Sierra et al.	2010/0030040 A1	2/2010	Poeze et al.
8,652,060 B2	2/2014	Al-Ali	2010/0261979 A1	10/2010	Kiani
8,663,107 B2	3/2014	Kiani	2010/0317936 A1	12/2010	Al-Ali et al.
8,666,468 B1	3/2014	Al-Ali	2011/0001605 A1	1/2011	Kiani et al.
8,667,967 B2	3/2014	Al-Ali et al.	2011/0082711 A1	4/2011	Poeze et al.
8,670,811 B2	3/2014	O'Reilly	2011/0105854 A1	5/2011	Kiani et al.
8,670,814 B2	3/2014	Diab et al.	2011/0208015 A1	8/2011	Welch et al.
8,676,286 B2	3/2014	Weber et al.	2011/0209915 A1	9/2011	Telfort et al.
8,682,407 B2	3/2014	Al-Ali	2011/0213212 A1	9/2011	Al-Ali
RE44,823 E	4/2014	Parker	2011/0230733 A1	9/2011	Al-Ali
RE44,875 E	4/2014	Kiani et al.	2011/0237911 A1	9/2011	Lamego et al.
8,690,799 B2	4/2014	Telfort et al.	2012/0059267 A1	3/2012	Lamego et al.
8,700,112 B2	4/2014	Kiani	2012/0116175 A1	5/2012	Al-Ali et al.
8,702,627 B2	4/2014	Telfort et al.	2012/0179006 A1	7/2012	Jansen et al.
			2012/0209082 A1	8/2012	Al-Ali
			2012/0209084 A1	8/2012	Olsen et al.
			2012/0227739 A1	9/2012	Kiani
			2012/0265039 A1	10/2012	Kiani

(56)

References Cited

U.S. PATENT DOCUMENTS

2012/0283524	A1	11/2012	Kiani et al.	2014/0121482	A1	5/2014	Merritt et al.
2012/0286955	A1	11/2012	Welch et al.	2014/0121483	A1	5/2014	Kiani
2012/0296178	A1	11/2012	Lamego et al.	2014/0125495	A1	5/2014	Al-Ali
2012/0319816	A1	12/2012	Al-Ali	2014/0127137	A1	5/2014	Bellott et al.
2012/0330112	A1	12/2012	Lamego et al.	2014/0128696	A1	5/2014	Al-Ali
2013/0023775	A1	1/2013	Lamego et al.	2014/0128699	A1	5/2014	Al-Ali et al.
2013/0041591	A1	2/2013	Lamego	2014/0129702	A1	5/2014	Lamego et al.
2013/0045685	A1	2/2013	Kiani	2014/0135588	A1	5/2014	Al-Ali et al.
2013/0046204	A1	2/2013	Lamego et al.	2014/0142401	A1	5/2014	Al-Ali et al.
2013/0060108	A1	3/2013	Schurman et al.	2014/0142402	A1	5/2014	Al-Ali et al.
2013/0060147	A1	3/2013	Welch et al.	2014/0163344	A1	6/2014	Al-Ali
2013/0079610	A1	3/2013	Al-Ali	2014/0163402	A1	6/2014	Lamego et al.
2013/0096405	A1	4/2013	Garfo	2014/0166076	A1	6/2014	Kiani et al.
2013/0096936	A1	4/2013	Sampath et al.	2014/0171763	A1	6/2014	Diab
2013/0109935	A1	5/2013	Al-Ali et al.	2014/0180038	A1	6/2014	Kiani
2013/0162433	A1	6/2013	Muhsin et al.	2014/0180154	A1	6/2014	Sierra et al.
2013/0190581	A1	7/2013	Al-Ali et al.	2014/0194709	A1	7/2014	Al-Ali et al.
2013/0197328	A1	8/2013	Diab et al.	2014/0194711	A1	7/2014	Al-Ali
2013/0211214	A1	8/2013	Olsen	2014/0194766	A1	7/2014	Al-Ali et al.
2013/0243021	A1	9/2013	Siskavich	2014/0200420	A1	7/2014	Al-Ali
2013/0253334	A1	9/2013	Al-Ali et al.	2014/0200422	A1	7/2014	Weber et al.
2013/0274571	A1	10/2013	Diab et al.	2014/0206963	A1	7/2014	Al-Ali
2013/0296672	A1	11/2013	O'Neil et al.	2014/0213864	A1	7/2014	Abdul-Hafiz et al.
2013/0317370	A1	11/2013	Dalvi et al.	2014/0243627	A1	8/2014	Diab et al.
2013/0324808	A1	12/2013	Al-Ali et al.	2014/0266790	A1	9/2014	Al-Ali et al.
2013/0331670	A1	12/2013	Kiani	2014/0275808	A1	9/2014	Poeze et al.
2013/0338461	A1	12/2013	Lamego et al.	2014/0275835	A1	9/2014	Lamego et al.
2014/0012100	A1	1/2014	Al-Ali et al.	2014/0275871	A1	9/2014	Lamego et al.
2014/0025306	A1	1/2014	Weber et al.	2014/0275872	A1	9/2014	Merritt et al.
2014/0034353	A1	2/2014	Al-Ali et al.	2014/0275881	A1	9/2014	Lamego et al.
2014/0051952	A1	2/2014	Reichgott et al.	2014/0288400	A1	9/2014	Diab et al.
2014/0051953	A1	2/2014	Lamego et al.	2014/0296664	A1	10/2014	Bruinsma et al.
2014/0051954	A1	2/2014	Al-Ali et al.	2014/0303520	A1	10/2014	Telfort et al.
2014/0058230	A1	2/2014	Abdul-Hafiz et al.	2014/0309506	A1	10/2014	Lamego et al.
2014/0066783	A1	3/2014	Kiani et al.	2014/0309559	A1	10/2014	Telfort et al.
2014/0077956	A1	3/2014	Sampath et al.	2014/0316228	A1	10/2014	Blank et al.
2014/0081100	A1	3/2014	Muhsin et al.	2014/0323825	A1	10/2014	Al-Ali et al.
2014/0081175	A1	3/2014	Telfort	2014/0330092	A1	11/2014	Al-Ali et al.
2014/0094667	A1	4/2014	Schurman et al.	2014/0330098	A1	11/2014	Merritt et al.
2014/0100434	A1	4/2014	Diab et al.	2014/0330099	A1	11/2014	Al-Ali et al.
2014/0114199	A1	4/2014	Lamego et al.	2014/0333440	A1	11/2014	Kiani
2014/0120564	A1	5/2014	Workman et al.	2014/0336481	A1	11/2014	Shakespeare et al.
				2014/0343436	A1	11/2014	Kiani
				2015/0018650	A1	1/2015	Al-Ali et al.

* cited by examiner

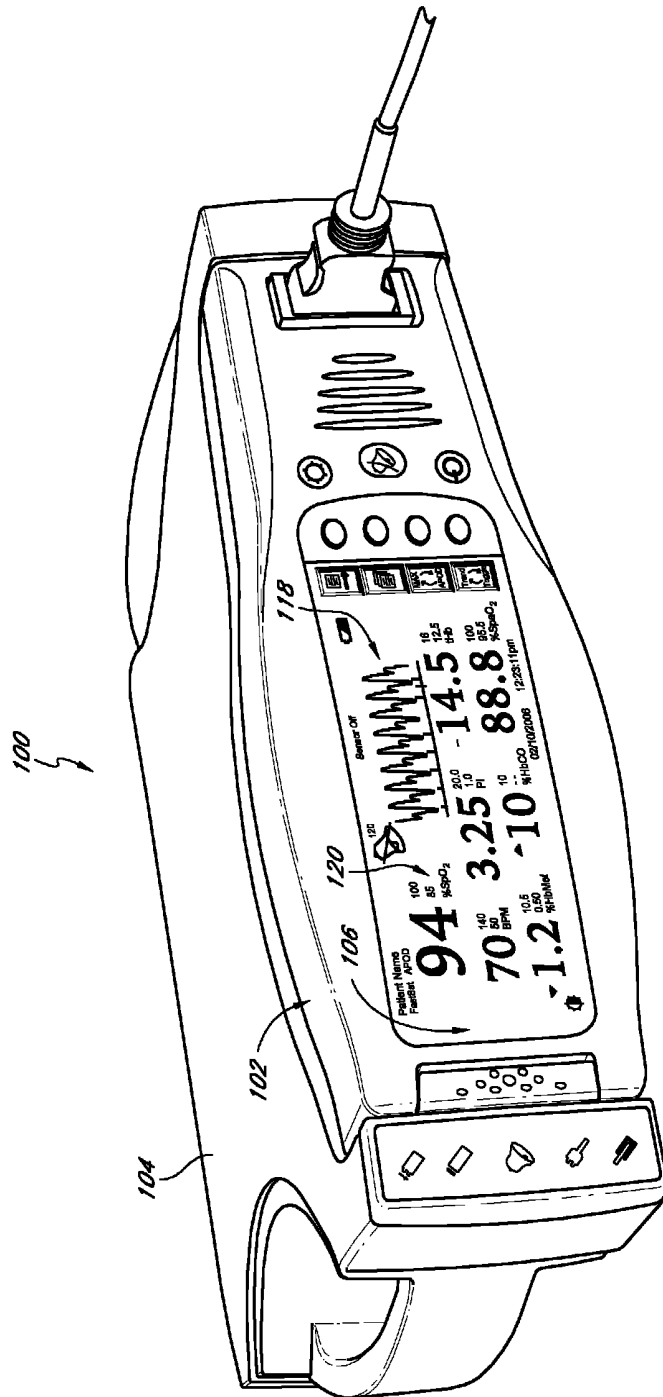

FIG. 1A

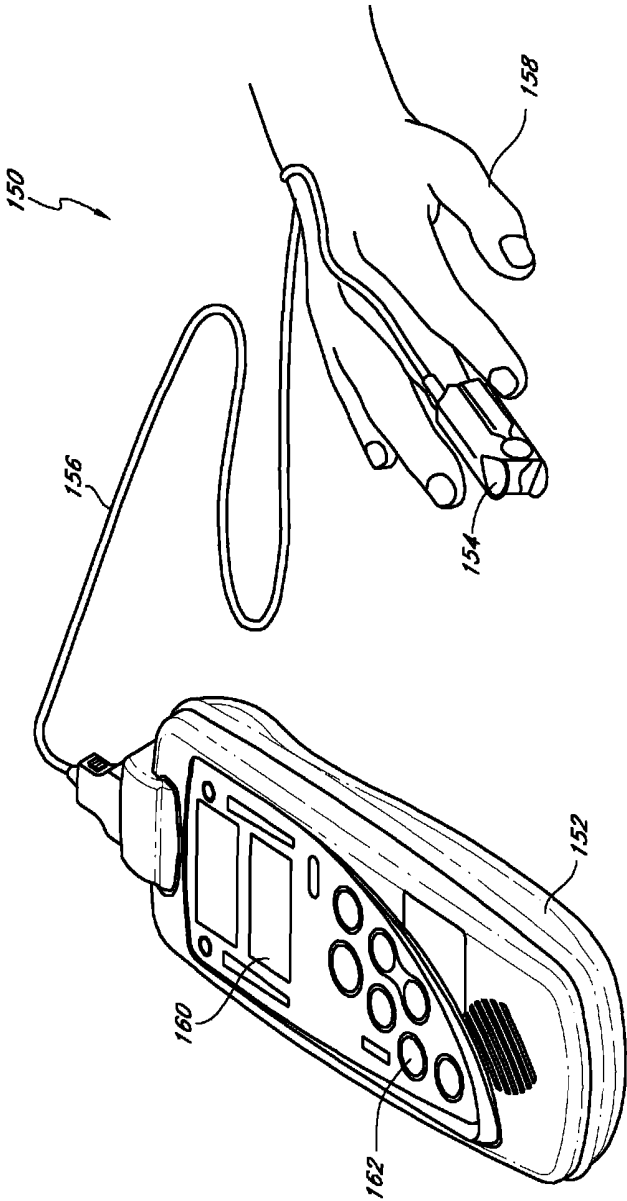

FIG. 1B

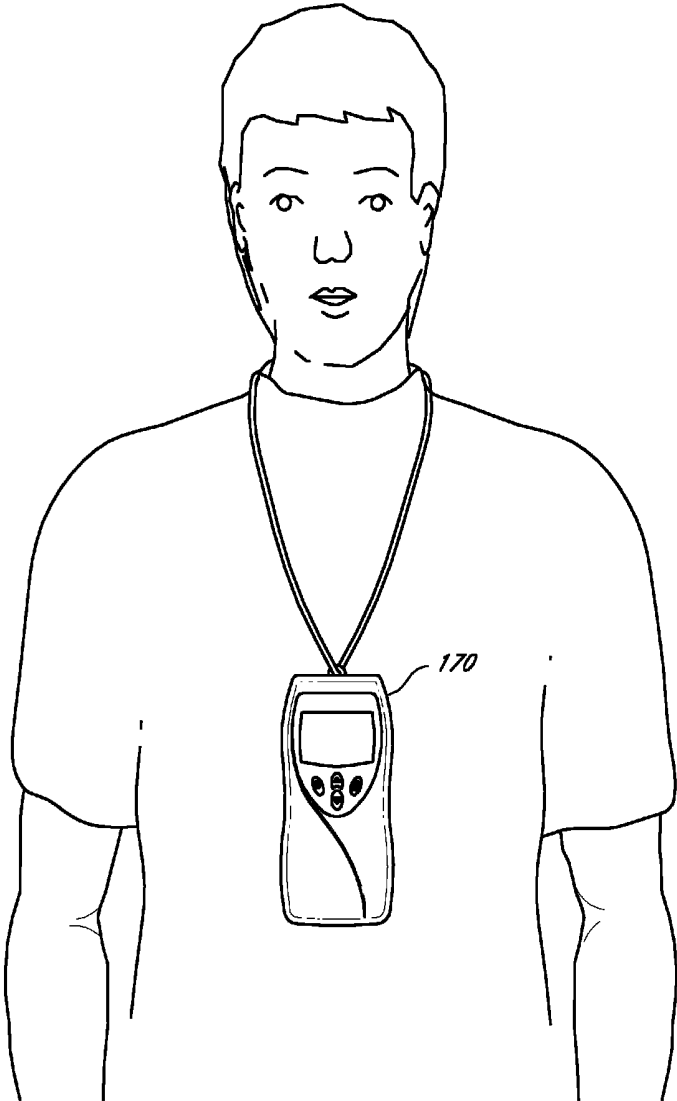

FIG. 1C

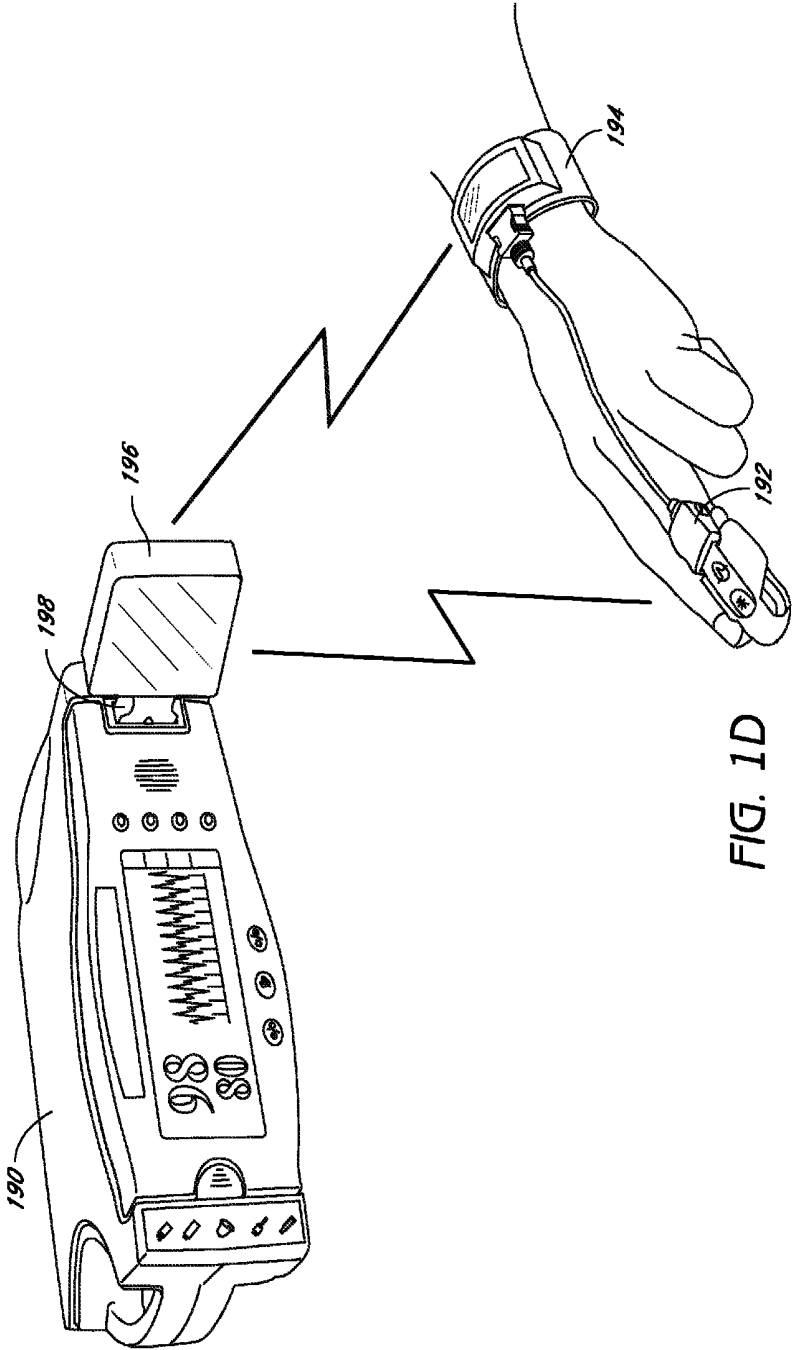

FIG. 1D

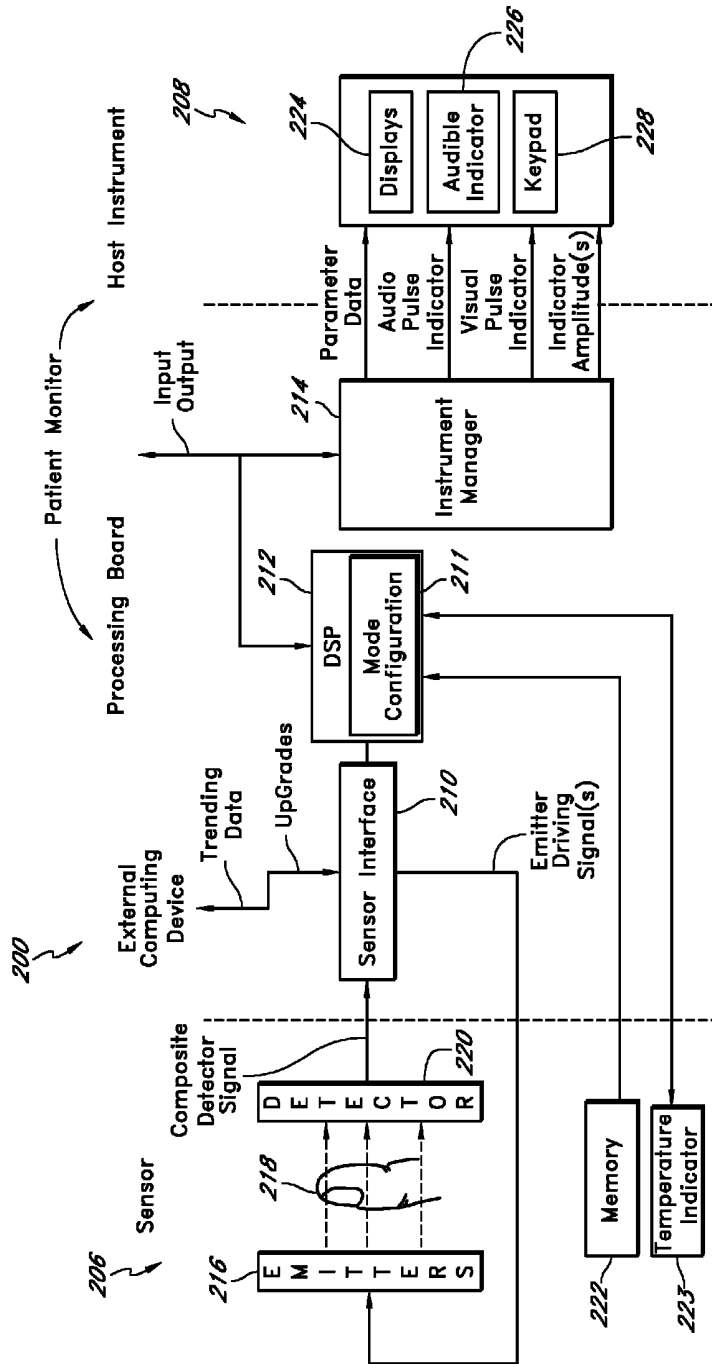

FIG. 2

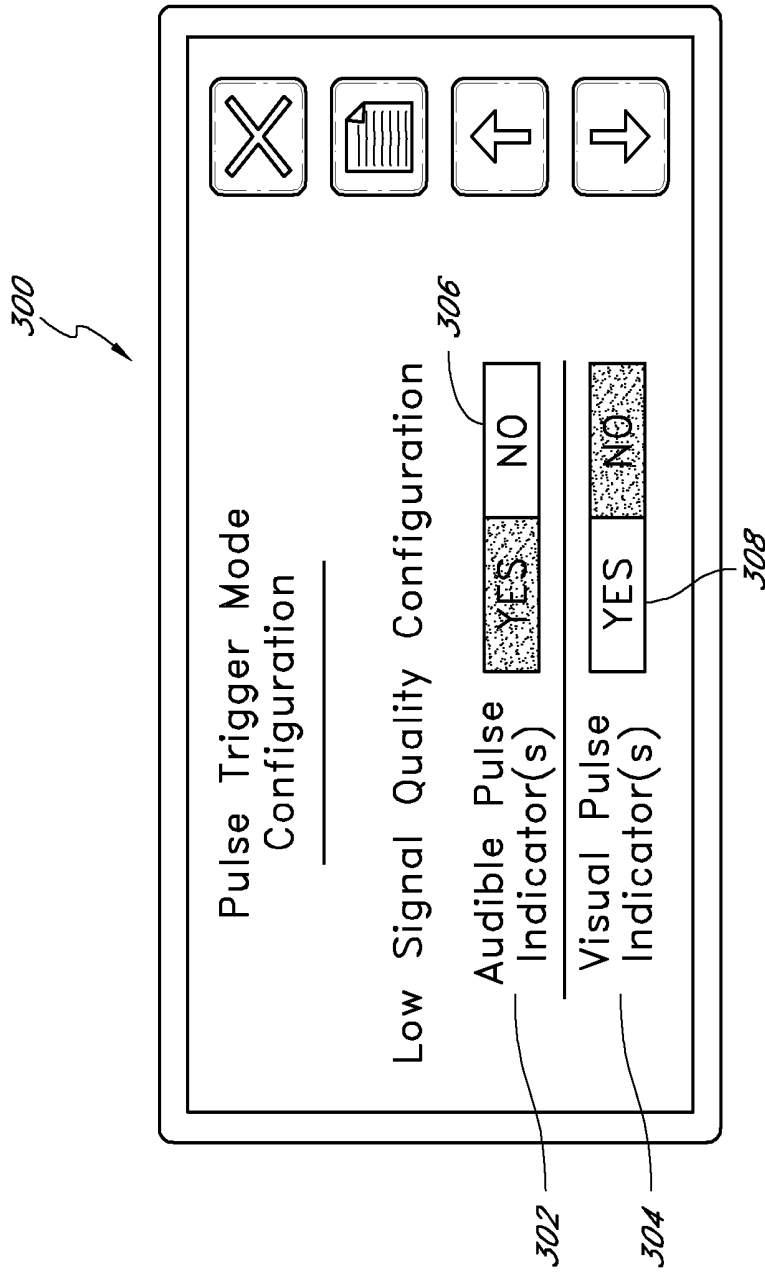

FIG. 3

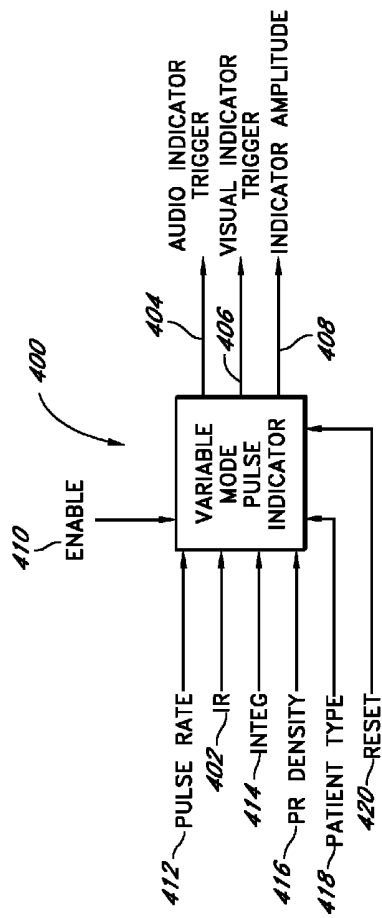

FIG. 4

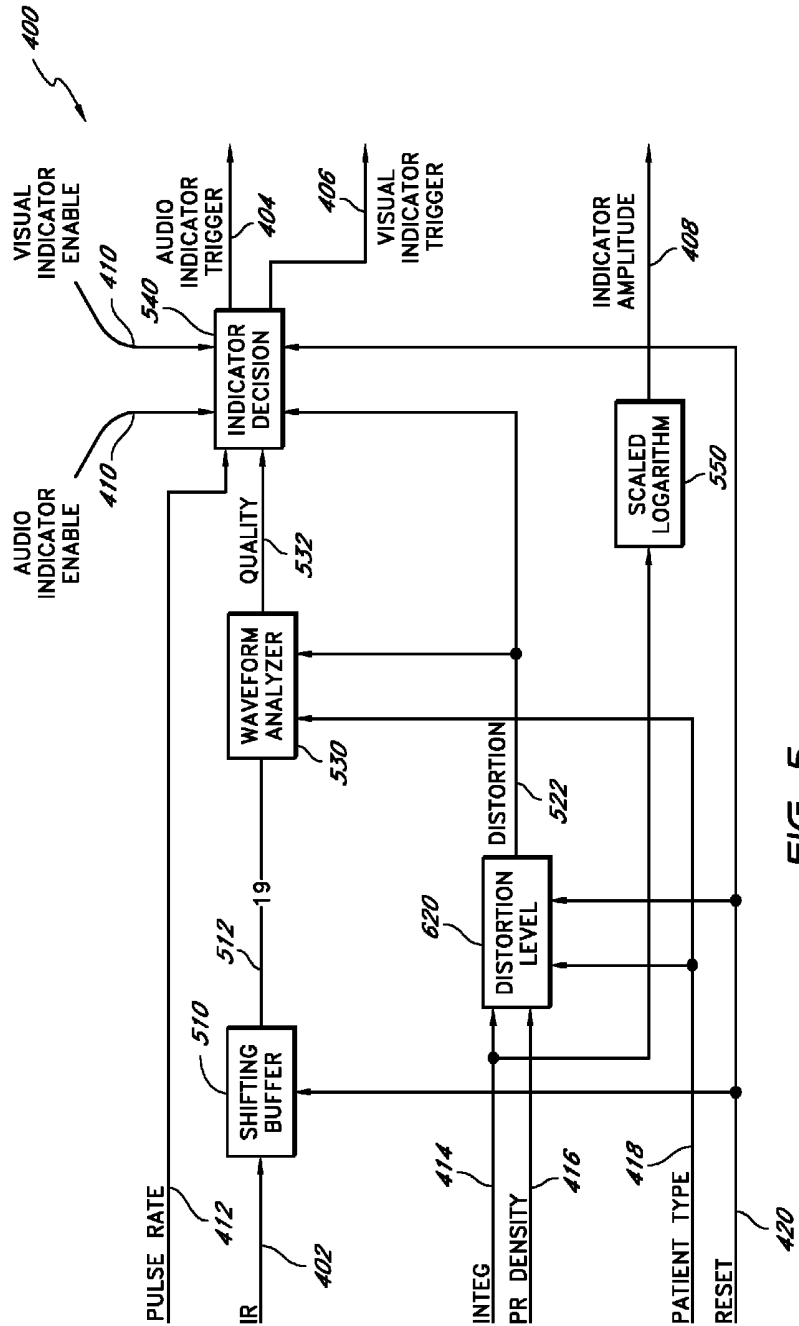

FIG. 5

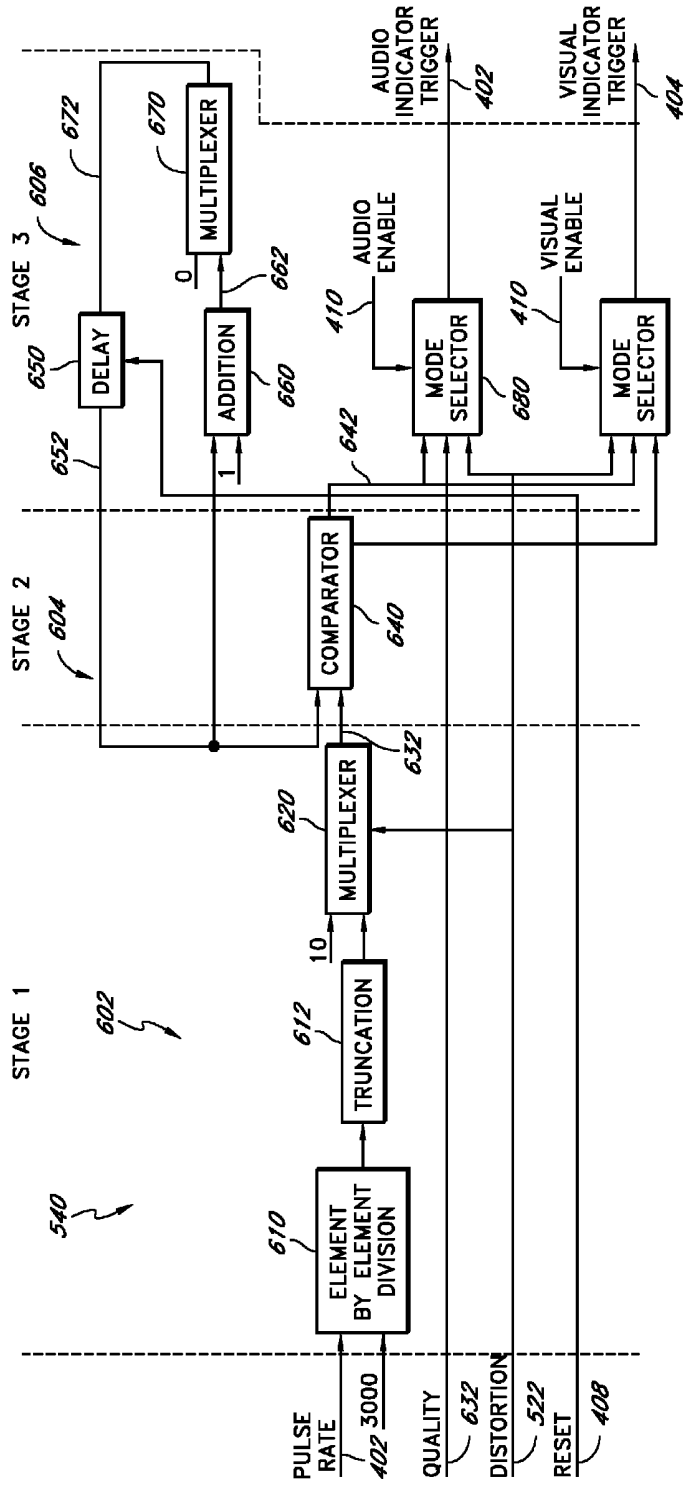

FIG. 6

VARIABLE MODE PULSE INDICATOR

PRIORITY CLAIM

This present application claims priority benefit under 35 U.S.C. §119(e) from U.S. Provisional Application No. 60/851,861, filed Oct. 12, 2006, entitled "Variable Mode Pulse Indicator," which is incorporated by reference herein.

CROSS-REFERENCE TO RELATED APPLICATIONS

The present application is related to U.S. Pat. No. 6,606,511, No. 6,002,952, No. 6,464,311, No. 6,684,090, No. 6,770,028, No. 6,850,788, and the continuation, continuation-in-part, and divisional applications thereof. The present application also incorporates the foregoing disclosures herein by reference.

BACKGROUND OF THE DISCLOSURE

1. Field of the Disclosure

The present disclosure relates in general to patient monitoring and in particular to oximeter patient monitors capable of monitoring one or more physiological parameters including a pulse rate from a noninvasive optical sensor.

2. Description of the Related Art

A desirable feature of patient monitors, including oximeters such as oximeters, co-oximeters, and the like, includes at least one of an audio and video indication of a pulse occurrence substantially corresponding to a patient's pulse. Such indications of a pulse occurrence may be caused by a trigger output used to initiate an audible tone "beep" or a visual pulse indication on a display.

In some systems, when signal(s) from a noninvasive optical sensor include sufficient distortion, high noise, or simply present low signal quality, pulse indications may be difficult to calculate. In some systems, the oximeter may simply determine that no pulse indication is presented to a caregiver.

In other systems, the oximeter may attempt to determine pulse occurrences during distortion, high noise, motion-induced noise, or during low signal quality or confidence. For example, in U.S. Pat. No. 6,606,511, which is assigned to Masimo Corporation ("Masimo") of Irvine, Calif., which is the assignee of the current application and incorporated by reference herein, a pulse trigger output from a rule-based processor is responsive to pulse waveforms of the patient's oximeter-derived photo-plethysmograph waveform in low-noise or no-distortion situations. However, during high-noise or distortion situations, the pulse trigger output may advantageously become dependent on an average or other statistical determination of the pulse rate. This "intelligent beep" reliably indicates the patient's pulse, yet responds to patient arrhythmias, asystole conditions and similar irregular plethysmographs. An example of the determination of pulse rate in the presence of distortion is described in U.S. Pat. No. 6,002,952, No. 6,463,311, No. 6,684,090, all of which are assigned to Masimo Corporation of Irvine, Calif., and incorporated by reference herein.

As disclosed in the '511 patent, when there is relatively no distortion corrupting a plethysmograph signal, the processor may analyze the shape of the pulses in the waveform to determine where in the waveform to generate the pulse indication. When distortion is present, looser waveform criteria can be used to determine if pulses are present. For example,

when pulses are present, the pulse indication is based upon an averaged pulse rate. If no pulses are present, no indication occurs.

In the disclosed embodiment, the pulse indicator provides a trigger and amplitude output. The trigger output is used to initiate an audible tone "beep" or a visual pulse indication on a display, such as a vertical spike on a horizontal trace, a rising pulsing or constant bar display, one or more specific colors of a displayed parameter or trace, one or more LEDs or other visual elements, combinations of the same, or the like. The amplitude output is used to indicate data integrity and corresponding confidence in the computed values of saturation and pulse rate. The amplitude output can vary a characteristic of the pulse indicator, such as beep volume or frequency or the height of the visual display spike.

SUMMARY OF THE DISCLOSURE

With the acceptance of oximeter systems that output audio and visual indications of pulse occurrences, caregivers have begun to rely on assumptions they make from such audio and visual queries. For example, when a caregiver is accustomed to oximeter systems that are simply silent during signal distortion, high-noise, or low signal quality conditions, that caregiver may make potentially inaccurate assumptions about a patient monitored by oximeter systems that attempt to find pulse occurrences through noise. For example, even when an oximeter system includes an output that adjusts a visual indication of a pulse occurrence to indicate poor signal conditions or low confidence in determined parameters, the actuation of an audible beep may lead a caregiver to believe that the signal conditions, and perhaps the monitored patient, are better than they actually are. Conversely, a caregiver accustomed to a monitor that attempts to provide indications of pulse occurrences through distortion and noise, such as the oximeters disclosed in the '511 patent, may make potentially inaccurate assumptions about a patient monitored by oximeter systems that simply go silent during more difficult signal conditions.

Based at least thereon, a need exists for a configurable oximeter that allows caregivers to configure pulse occurrence indications to match their expectations. Therefore, in an embodiment of the disclosure, an oximeter includes a variable mode oximetry pulse indicator responsive to modes selected by a user or caregiver. For example, one mode may disable audio and visual pulse occurrence indications, another mode may disable one or the other, and yet another mode may enable audio and visual pulse occurrence indications during defined noisy conditions. In an embodiment, the user may cycle through or otherwise select the particular mode using user configuration menus and user input devices, such as, for example, a keypad or other user interface/input device.

BRIEF DESCRIPTION OF THE DRAWINGS

A general architecture that implements the various features of the disclosure will now be described with reference to the drawings. The drawings and the associated descriptions are provided to illustrate embodiments of the disclosure and not to limit its scope.

FIGS. 1A-1D illustrate various exemplary oximeter patient monitoring systems.

FIG. 2 illustrates an exemplary block diagram of one or more of the oximeter patient monitoring systems of FIG. 1.

FIG. 3 illustrates an exemplary user interface providing user configuration of pulse indicators during signal distortion

in one or more signals acquired from, for example, a non-invasive optical sensor, according to an embodiment of the disclosure.

FIG. 4 illustrates exemplary inputs and outputs of a variable mode oximetry pulse indicator, according to an embodiment of the disclosure.

FIG. 5 illustrates an exemplary block diagram of a variable mode oximetry pulse indicator, according to an embodiment of the disclosure.

FIG. 6 illustrates an exemplary block diagram of an indicator decision module of the variable mode oximetry pulse indicator of FIG. 5, according to an embodiment of the disclosure.

DETAILED DESCRIPTION OF THE PREFERRED EMBODIMENT

Embodiments of the present disclosure include a user-configurable oximetry pulse indicator. For example, a user may configure whether one or more of audio and visual indicators of pulse occurrences is presented to a caregiver during, for example, distortion, motion-induced noise, low signal quality, or other challenging signal conditions. In an embodiment, a first mode presents audio and visual indicators of a patient's pulse to a caregiver during challenging signal conditions, while a second and third mode presents one or the other respectively, and a fourth mode blocks or otherwise diminishes the influence of the audio and visual indicators.

In an embodiment, an enable signal is generated according to the user's configurations and a pulse indicator is responsive to the enable signal. For example, a pulse indicator may advantageously determine a pulse occurrence and generate an indicator trigger. Depending upon the particular mode configured by the user, the pulse indicator trigger, and in some embodiments, a pulse indicator amplitude may advantageously be forwarded to tone and display generators. Alternatively, depending upon the particular mode, the indicator trigger and indicator amplitude may be partially or entirely blocked or otherwise diminished to match expectations of the caregiver in challenging signal conditions.

To facilitate a further understanding of the disclosure, the remainder of the description describes the invention with reference to specific drawings. Moreover, in this application, reference may be made to many blood parameters. Some references that have common shorthand designations are referenced through such shorthand designations. For example, as used herein, HbCO designates carboxyhemoglobin, HbMet designates methemoglobin, Hbt designates total hemoglobin, SpO₂ designates functional arterial saturation, and SpaO₂ designates fractional arterial saturation. Other shorthand designations such as COHb, MetHb, and tHb are also common in the art for these same constituents. These constituents are generally reported in terms of a percentage, often referred to as saturation, relative concentration, concentration, or fractional saturation. Total hemoglobin is generally reported as a concentration in g/dL. The use of the particular shorthand designators presented in this application does not restrict the term to any particular manner in which the designated constituent is reported.

FIG. 1A illustrates a perspective view of a patient monitor system 100, according to an embodiment of the present disclosure. The system 100 includes a portable patient monitor 102 capable of noninvasively determining one or more physiological parameters. In an embodiment, the portable patient monitor 102 mechanically and electrically mates with a docking station 104 to recharge batteries, upload and download information, upgrade software or firmware, communicate

with other monitors or the like. Disclosures of various docking stations are disclosed with reference to U.S. Pat. No. 6,770,028, incorporated above.

FIG. 1A also illustrates the monitor 102 comprising one or more displays 106 capable displaying of a wide variety of measured values in a manner that provides for quick and efficient conveyance of information to a caregiver. For example, the display 106 displays values for HbCO, HbMet, MbT, SpO₂, SpaO₂, beats-per-minute, scaled plethysmograph data 118, P1™ 120 and other information.

FIG. 1B illustrates a perspective view of a monitoring system 150 including a handheld noninvasive multi-parameter patient monitor 152 communicating with a reusable optical sensor 154 through a patient cable 156, according to embodiments of the disclosure. In general, the monitor 152 drives the sensor 154 to emit light of differing wavelengths into the body tissue 158. The sensor 154 detects the light after attenuation by the body tissue 158 and outputs a signal indicative of the amount of light received by the sensor 154 through the cable 156. In addition, in some embodiments, the monitor 152 communicates with a temperature sensor and a memory device associated with one or more of the sensor 154 and the cable 156, through the cable 156.

In an embodiment, the monitors 102, 152 receive sensor output and determine continuous and non-invasive measurements of a wide variety of blood parameters. Although disclosed with reference to portable monitors 102, 152, an artisan will recognize from the disclosure herein that aspects of the present disclosure can be adopted into tabletop monitors, wireless sensors, or other patient-wearable personal monitors, or multi-parameter patient monitors.

FIG. 1B also shows the sensor 154 comprising a reusable sensor in the form a clip including a spring biased pivot point capable of removably attaching the reusable sensor to a patient's finger 158. Although disclosed with reference to a reusable sensor having a spring, an artisan will recognize from the disclosure herein that the sensor 154 can advantageously comprise a disposable adhesive type sensor, a combination sensor including reusable and disposable components, components incorporated into other medical devices such as catheters, or the like, or other reusable sensor designs. Moreover, the artisan will recognize from the disclosure herein that the sensor 154 can comprise mechanical structures, adhesive or other tape structures, Velcro wraps or combination structures specialized for the type of patient, type of monitoring, type of monitor, or the like. In an embodiment, the sensor 154 provides data to the monitors 102, 152 and vice versa through the cable 156, although such communication can advantageously be wireless, over public or private networks or computing systems or devices, through intermediate medical or other devices, combinations of the same, or the like.

In an embodiment, the monitor 152 includes one or more displays 160 capable of displaying, for example, one or more of the foregoing parameters. For example, the display 160 may provide an indication of HbCO, HbMet, Hbt, SpO₂, SpaO₂, pulse rate, plethysmographs, historical or trending data, confidence or perfusion indicators, or the like. The monitors 102, 152 may include one or more audio, visual or messaging (pagers, emails, instant and phone messages, vocally presented numbers, messages and alarms, voice-over-IP ("VOIP") interfaces and functionality, or the like) alarms, user input keypad 160, or the like.

Although described in terms of certain embodiments, other embodiments or combination of embodiments will be apparent to those of ordinary skill in the art from the disclosure herein. For example, the monitors 102, 152 may combine

other information with intensity-derived information to influence diagnoses or device operation. For example, patterns or changes in the continuous noninvasive monitoring of intensity-derived information may cause the activation of other vital sign measurement devices, such as, for example, blood pressure cuffs.

FIG. 1C illustrates a perspective view of a monitoring system including a personal or wearable noninvasive multi-parameter patient monitor **170**, according to embodiments of the disclosure. Such personal oximeters **170** generally wirelessly communicated with a monitoring station to provide the monitoring station with measurements for some or all of the physiological parameters measurable by the monitor. In an embodiment, the monitor travels with a patient as the patient, for example, moves through a care site such as a hospital. Wireless networks incorporating such personal pulse technologies are commercially available from Masimo marketed under the brand RadNet™, RadLink™ and Patient Safety Net™.

FIG. 1D illustrates a perspective view of a monitoring system including a wireless noninvasive multi-parameter patient monitor **190**, according to embodiments of the disclosure. In an embodiment, a traditional sensor **192** communicates with a wireless transmission device **194** wearable, for example, on the wrist. In other embodiments, the wireless transmission device may advantageously be incorporated into a sensor housing adapted for wireless communication. In an embodiment, a wireless receiver **196** communicates with a sensor port **198** in the same manner as a wired sensor. Thus, in an exemplary embodiment shown in FIG. 1D, a traditional sensor **192** and a traditional sensor port **198** may be unaware that a patient cable has been replaced with wireless transmissions. Disclosure of wireless technologies is disclosed in U.S. Pat. No. 6,850,788, incorporated by reference herein.

FIG. 2 illustrates an exemplary block diagram of an embodiment of a patient monitoring system **200**. As shown in FIG. 2, the system **200** includes a patient monitor **202** comprising a processing board **204** and a host instrument **208**. The processing board **204** communicates with a sensor **206** to receive one or more intensity signal(s) indicative of one or more parameters of tissue of a patient. The processing board **204** also communicates with a host instrument **208** to display determined parameter values calculated using the one or more intensity signals. According to an embodiment, the board **204** comprises processing circuitry arranged on one or more printed circuit boards capable of installation into the monitor **202**, or capable of being distributed as some or all of one or more OEM components for a wide variety of host instruments monitoring a wide variety of patient information. In an embodiment, the processing board **202** comprises a sensor interface **210**, a digital signal processor and signal extractor (“DSP” or “processor”) **212**, and an instrument manager **214**. In general, the sensor interface **210** converts digital control signals into analog drive signals capable of driving sensor emitters, and converts composite analog intensity signal(s) from light sensitive detectors into digital data.

In an embodiment, the sensor interface **210** manages communication with external computing devices. For example, in an embodiment, a multipurpose sensor port (or input/output port) is capable of connecting to the sensor **206** or alternatively connecting to a computing device, such as a personal computer, a PDA, additional monitoring equipment or networks, or the like. When connected to the computing device, the processing board **204** may upload various stored data for, for example, off-line analysis and diagnosis. The stored data may comprise trend data for any one or more of the measured parameter data, plethysmograph waveform data acoustic

sound waveform, or the like. Moreover, the processing board **204** may advantageously download from the computing device various upgrades or executable programs, may perform diagnosis on the hardware or software of the monitor **202**. In addition, the processing board **204** may advantageously be used to view and examine patient data, including raw data, at or away from a monitoring site, through data uploads/downloads, or network connections, combinations, or the like, such as for customer support purposes including software maintenance, customer technical support, and the like.

As shown in FIG. 2, the digital data is output to the DSP **212**. According to an embodiment, the DSP **212** comprises a processing device based on the Super Harvard ARCHitecture (“SHARC”), such as those commercially available from Analog Devices. However, a skilled artisan will recognize from the disclosure herein that the DSP **212** can comprise a wide variety of data and/or signal processors capable of executing programs for determining physiological parameters from input data. In particular, the DSP **212** includes program instructions capable of receiving multiple channels of data related to one or more intensity signals representative of the absorption (from transmissive or reflective sensor systems) of a plurality of wavelengths of emitted light by body tissue. In an embodiment, the DSP **212** accepts data related to the absorption of two (2) to eight (8) wavelengths of light, although an artisan will recognize from the disclosure herein that the data can be related to the absorption of two (2) to sixteen (16) or more wavelengths.

FIG. 2 also shows the processing board **204** including the instrument manager **214**. According to an embodiment, the instrument manager **214** may comprise one or more microcontrollers controlling system management, including, for example, communications of calculated parameter data and the like to the host instrument **208**. The instrument manager **214** may also act as a watchdog circuit by, for example, monitoring the activity of the DSP **212** and resetting it when appropriate.

The sensor **206** may comprise any commercially available noninvasive oximetry sensor. In an embodiment, the sensor **206** provides data to the board **204** and vice versa through, for example, a patient cable. An artisan will also recognize from the disclosure herein that such communication can be wireless, over public or private networks or computing systems or devices, or the like.

As shown in FIG. 2, the sensor **206** includes a plurality of emitters **216** irradiating the body tissue **218** with differing wavelengths of light, and one or more detectors **220** capable of detecting the light after attenuation by the tissue **218**. The sensor **206** may also include other electrical components such as, for example, a memory device **222** comprising an EPROM, EEPROM, ROM, RAM, microcontroller, combinations of the same, or the like. In an embodiment, other sensor components may include a temperature determination device **223** or other mechanisms for, for example, determining real-time emission wavelengths of the emitters **216**.

The memory **222** may advantageously store some or all of a wide variety data and information, including, for example, information on the type or operation of the sensor **206**; type or identification of sensor buyer or distributor or groups of buyer or distributors, sensor manufacturer information, sensor characteristics including the number of emitting devices, the number of emission wavelengths, data relating to emission centroids, data relating to a change in emission characteristics based on varying temperature, history of the sensor temperature, current, or voltage, emitter specifications, emitter drive requirements, demodulation data, calculation mode data, the

parameters for which the sensor is capable of supplying sufficient measurement data (e.g., HpCO, HpMet, Hbt, or the like), calibration or parameter coefficient data, software such as scripts, executable code, or the like, sensor electronic elements, whether the sensor is a disposable, reusable, multi-site, partially reusable, partially disposable sensor, whether it is an adhesive or non-adhesive sensor, whether the sensor is a reflectance, transmittance, or transreflectance sensor, whether the sensor is a finger, hand, foot, forehead, or ear sensor, whether the sensor is a stereo sensor or a two-headed sensor, sensor life data indicating whether some or all sensor components have expired and should be replaced, encryption information, keys, indexes to keys or hash functions, or the like, monitor or algorithm upgrade instructions or data, some or all of parameter equations, information about the patient, age, sex, medications, and other information that may be useful for the accuracy or alarm settings and sensitivities, trend history, alarm history, or the like. In an embodiment, the monitor may advantageously store data on the memory device, including, for example, measured trending data for any number of parameters for any number of patients, or the like, sensor use or expiration calculations, sensor history, or the like.

FIG. 2 also shows the patient monitor 202 including the host instrument 208. In an embodiment, the host instrument 208 communicates with the board 204 to receive signals indicative of the physiological parameter information calculated by the DSP 212. The host instrument 208 preferably includes one or more display devices 224 capable of displaying indicia representative of the calculated physiological parameters of the tissue 218 at the measurement site including for example pulse occurrence indicia. In an embodiment, the host instrument 208 may advantageously comprise a handheld housing capable of displaying parameter data, including but not limited to pulse rate, plethysmograph data, perfusion quality such as a perfusion quality index ("PITM"), signal or measurement quality ("SQ"), values of blood constituents in body tissue, including for example, SPO₂, HbCO, HbMet, Hbt, or the like. In other embodiments, the host instrument 208 is capable of displaying values for one or more of Hbt, Hb, blood glucose, bilirubin, or the like. The host instrument 208 may be capable of storing or displaying historical or trending data related to one or more of the measured values, combinations of the measured values, plethysmograph data, or the like. The host instrument 208 also includes an audio indicator 226 and user input device 228, such as, for example, a keypad, touch screen, pointing device, voice recognition device, or the like.

In still additional embodiments, the host instrument 208 includes audio or visual alarms that alert caregivers that one or more physiological parameters are falling below predetermined safe thresholds. The host instrument 208 may include indications of the confidence a caregiver should have in the displayed data. In a further embodiment, the host instrument 208 may advantageously include circuitry capable of determining the expiration or overuse of components of the sensor 206, including, for example, reusable elements, disposable elements, or combinations of the same.

The monitor 202 also includes a mode configuration 211 accessible to the DSP 212 and responsive to inputs from, for example, the user input device 218. The mode configuration advantageously provides a caregiver the ability to configure pulse indicators in low signal quality conditions.

Although described in terms of certain embodiments, other embodiments or combination of embodiments will be apparent to those of ordinary skill in the art from the disclosure herein. For example, the monitor 202 may comprise one or

more monitoring systems monitoring parameters, such as, for example, vital signs, blood pressure, ECG or EKG, respiration, glucose, bilirubin, or the like. Such systems may combine other information with intensity-derived information to influence diagnosis or device operation. Moreover, the monitor 202 may advantageously include an audio system, preferably comprising a high quality audio processor and high quality speakers to provide for voiced alarms, messaging, or the like. In an embodiment, the monitor 202 may advantageously include an audio out jack, conventional audio jacks, headphone jacks, or the like, such that any of the display information disclosed herein may be audibilized for a listener. For example, the monitor 202 may include an audible transducer input (such as a microphone, piezoelectric sensor, or the like) for collecting one or more of heart sounds, lung sounds, trachea sounds, or other body sounds and such sounds may be reproduced through the audio system and output from the monitor 202. Also, wired or wireless communications (such as Bluetooth or WiFi, including IEEE 801.11a, b, or g), mobile communications, combinations of the same, or the like, may be used to transmit the audio output to other audio transducers separate from the monitor 202. Moreover, patterns or changes in the continuous noninvasive monitoring of intensity-derived information may cause the activation of other vital sign measurement devices, such as, for example, blood pressure cuffs.

FIG. 3 illustrates an exemplary user interface 300 providing user configuration of pulse indicators during signal distortion, according to an embodiment of the disclosure. In an embodiment, a user interacts with a user input device to configure certain behaviors of the patient monitor, including configuration of the audio and visual pulse indicators. As shown in FIG. 3, the interface 300 includes selectable or configurable parameters for one or both of the audible and visual pulse indicators 302, 304, respectively. For example, a user may determine that unless the instrument receives a strong signal quality, the user does not want to hear pulse indications; however, the user may want the visual indications to remain for purposes of trending, marking, closer inspection, diagnosis, or the like. In such case, the user may advantageously select "NO" 306 for the audio pulse indication configuration 302 and select "YES" 308 for the visual pulse indication configuration 304.

Although disclosed with reference to individual configuration of audio and visual pulse indications during low signal quality or confidence, an artisan will recognize from the disclosure herein a wide variety of user configurations as varying levels of detail to allow a user to customize the response of the patient monitor to varying signal quality. For example, the interface 300 may include configuration of modes governing the use of the pulse indicator amplitude for audio and visual indicators, configuration settings for a wide variety of differing audio and visual indications, such as, for example, coloring, trace characteristics, plethysmograph characteristics, trending characteristics, memory storage, varying frequencies, volume, voice messages, paging, other alarming, configuring the behavior of a bar graph, LED train, or the like.

FIG. 4 illustrates exemplary inputs and outputs of a variable mode oximetry pulse indicator 400, according to an embodiment of the disclosure. In an embodiment, the indicator 400 can be incorporated into an oximeter to trigger the occurrence of a synchronous indication of each of the patient's arterial pulses. The indicator 400 operates on, for example, an IR signal input 402 and generates an audio trigger output 404, a visual trigger output 406, and an amplitude output 408. The output 404 can be connected to a tone gen-

erator within the oximeter monitor **202** to create, for example, a fixed-duration audible “beep” as a pulse indication. Alternatively, or in addition, the output **406** can be connected to a display generator within the oximeter monitor **202** to create one or more visual pulse indications. The visual pulse indications can include a continuous horizontal trace on a CRT, LCD display or similar display device, where vertical spikes occur in the trace synchronously with the patient’s pulse. The visual pulse indications may also include a bar display, such as a vertically- or horizontally-arranged stack of LEDs or similar display device, where, for example, the bar pulses synchronously with the patient’s pulse. The visual indications may include changing colors, textual or graphical information, trace data, plethysmograph data, or the like. In an embodiment, an enable signal **410** responsive to the mode configuration **211** of FIG. 4, dictates whether all, some, or none of the outputs **404**, **406** and **408** are output to the audio and visual mechanisms of the host instrument **208**.

FIG. 4 also shows the amplitude output **408** used to vary one or more of the audible or visual indications so as to designate input data integrity and a corresponding confidence in the parameter and pulse rate outputs of the oximeter. For example, the height of a vertical spike can be varied in proportion to the amplitude output **408**, where a large or small vertical spike would correspondingly designate high or low confidence. As another example, the amplitude output **408** can be used to vary the volume of the audible beep or to change the visual indication (e.g., change color or the like) to similarly designate a high or low confidence. One of ordinary skill in the art will recognize that the trigger outputs **404**, **406** and amplitude output **408** can be utilized to generate a variety of audible and visual indications of a patient’s pulse and data integrity within the scope of this disclosure.

Other inputs to the variable mode pulse indicator **400** include pulse rate **412**, Integ (data integrity) **414**, PR (pulse rate) density **416**, patient type **418** and reset **420**, which are described in detail in U.S. Pat. No. ’511, referenced in the foregoing. The trigger decisions involve rule-based processes that advantageously respond to the pulse waveforms of the patient’s plethysmograph in low-noise or no-distortion situations. However, the trigger decisions may become dependent on the configuration parameters to determine what, if any, outputs occur and how those outputs will be audio and/or visually communicated to a caregiver.

The pulse rate input **412** to the pulse indicator **400** provides the frequency of the patient’s pulse rate in beats per minute. Pulse rate can be determined as described in U.S. patent application Ser. No. 08/834,194 or U.S. patent application entitled “Plethysmograph Pulse Recognition Processor,” both cited above. The Integ output **414** is a measure of the integrity of the IR **402** and Red input signals. In an embodiment, the measure is derived from signals from the sensor **206** as processed by an adaptive noise canceller. The PR density input **416** may comprise a ratio of the sum of the periods of recognizable pulses within a waveform segment divided by the length of the waveform segment. This parameter represents the fraction of the waveform segment that can be classified as having physiologically acceptable pulses. In one embodiment, a segment represents a snapshot of 400 samples of a filtered input waveform, or a 6.4 second “snapshot” of the IR waveform at a 62.5 Hz sampling rate. The derivation of Integ output **414** and PR density is described in U.S. Pat. No. 6,464,311 entitled “Plethysmograph Pulse Recognition Processor,” and cited above. The patient type **418** comprises a Boolean value that indicates either an adult sensor or a neonate sensor is in use. The reset **420** initializes the state of the pulse indicator **400** to known values upon power-up and dur-

ing periods of recalibration, such as when a new sensor is attached or a patient cable is reconnected.

FIG. 5 illustrates an exemplary functional block diagram of a variable mode oximetry pulse indicator **400**, according to an embodiment of the disclosure. As shown in FIG. 5, the indicator **400** includes a shifting buffer **510**, a distortion level function **520**, a waveform analyzer **530**, and an indicator decision **540**, which together produce the indicator triggers **404**, and **406**. The pulse indicator **400** also includes a scaled logarithm function **550** that produces the indicator amplitude output **408**. The shifting buffer **510** accepts the IR input **402** and provides a vector output **512** representing a fixed-size segment of the patient’s plethysmograph input to the waveform analyzer **530**. The distortion level function **520** determines the amount of distortion present in the IR input signal **402**. The inputs to the distortion level function **520** are the Integ input **414** and the PR density input **416**. The distortion output **522** is a Boolean value that is “true” when distortion in the IR input **402** is above a predetermined threshold. The distortion output **522** is input to the waveform analyzer **530** and the indicator decision **540**. The distortion output **522** determines the thresholds for the waveform analyzer **530**. The distortion output **522** also affects the window size within which a pulse indication can occur. The distortion output **522** is also a function of the patient type input **418**, which indicates whether the patient is an adult, a neonate, or the like.

In general, the waveform analyzer **530** determines whether a particular portion of the IR input **402** is an acceptable place for a pulse indication. The input to the waveform analyzer **530** is the vector output **512** from the shifting buffer **510**, creating a waveform segment. A waveform segment portion meets the acceptance criteria for a pulse when it satisfies one of three conditions. These conditions are a sharp downward edge, a peak in the middle with symmetry with respect to the peak, and a peak in the middle with a gradual decline. If one of these criteria is met, the waveform analyzer “quality” output **532** is “true.” Different criteria are applied depending on the state of the distortion output **522**, which is also a waveform analyzer input. If the distortion output **522** indicates no distortion, strict criteria are applied to the waveform shape. If the distortion output **522** indicates distortion, looser criteria are applied to the waveform shape. Different criteria are also applied for waveforms obtained from adult and neonate patients, as indicated by the patient type **406**.

The indicator decision **540** determines whether to trigger a pulse indication at a particular sample point of the input waveform. Specifically, the indicator decision **540** determines, in conjunction with the mode configuration **211**, whether to, and if it is the right place to, trigger a pulse indication. The decision as to whether to trigger the pulse indication is configured by the user through the mode configuration **211**. The enable signal **410** is responsive to the mode configuration **211**, and, in the case one or both of the distortion and quality signals **522** and **532** indicating poor signal quality, the indicator decision **540** determines whether some, all, or none of the audio and visual triggers **404** will pass to the audio and display devices of the host instrument **208**. In an embodiment, the enable signal **410** may comprise Boolean high and low signals and the mode selector may comprise logical gates configured to pass or block signals based on the enable signal **410**.

In addition to the enable signals **410**, the decision as to the right place to trigger a pulse indication is a function of the analyzer output **532**, which is one input to the indicator decision **540**. The decision as to the right time for an indicator trigger is a function of the state of the distortion output **522**, which is another input to the indicator decision **540**. If the

distortion output **522** is “false”, i.e. no distortion is detected in the input waveform, then a fixed minimum time gap from the last indicator must occur. In a particular embodiment, this minimum time gap is 10 samples. If the distortion output **522** is “true”, i.e. distortion is detected in the input waveform, then the minimum time gap is a function of the pulse rate input **412**. Additional details are disclosed in co-owned U.S. Pat. No. ’511, referenced in the foregoing.

FIG. **6** illustrates an exemplary block diagram of the indicator decision module **540** of the variable mode oximetry pulse indicator **400** of FIG. **5**, according to an embodiment of the disclosure. As shown in FIG. **6**, a first stage **602** of the indicator decision **640** determines a minimum time gap after which a pulse indicator can occur. The second stage **604** determines whether the number of samples since the last indicator is greater than the minimum allowed pulse gap. The third stage **606** decides whether to generate a pulse indicator trigger. If no trigger occurs, a sample count is incremented. If an indicator trigger occurs, the sample count is reset to zero.

The first stage **602** has a divider **610**, a truncation **620** and a first multiplexer **630**. These components function to set the minimum allowable gap between pulse indications. Under no distortion, the minimum gap is 10 samples. Under distortion, the gap is determined by the pulse rate. Specifically, under distortion, the minimum gap is set at about 80% of the number of samples between pulses as determined by the pulse rate input **402**. This may be computed as about 0.8 times the sample frequency, such as, for example, 62.5 Hz., divided by the pulse rate in pulses per second.

The divider **610** computes 3000/pulse rate. The divider output **612** is truncated **620** to an integer value. The first multiplexer **630** selects the minimum gap as either 10 samples if the distortion input **622** is “false” or the truncated value of 3000/pulse rate if the distortion input **622** is “true.” The selected value is provided on the multiplexer output **632**, which is fed to the second stage **604**. The second stage **604** is a comparator **640**, which provides a Boolean output **642** that is “true” if a counter output **652** has a value that is equal to or greater than the minimum gap value provided at the first multiplexer output **632**.

FIG. **6** also illustrates the third stage **606**, which has a counter and one or more mode selector function. The counter comprises a delay element **650** providing the counter output **652**, an adder **660** and a second multiplexer **670**. When the counter is initialized, the second multiplexer **670** provides a zero value on the multiplexer output **672**. The multiplexer output **672** is input to the delay element, which delays the multiplexer output value by one sample period before providing this value at the counter output **652**. The counter output **652** is incremented by one by the adder **660**. The adder output **662** is input to the second multiplexer **662**, which selects the adder output **662** as the multiplexer output **672** except when the counter is initialized, as described above. The counter is initialized to zero when the pulse indicator trigger **404**, **406** are “true” as determined by the output of the mode selectors **680**.

The mode selectors **680** include inputs of the quality **532**, the distortion **522**, the enable signal **410**, and the output of the comparator **642**, and respectively outputs the triggers **404**, **406**. In an embodiment, the mode selectors **680** each comprise a logical combination of the input signals to determine the output signal. For example, a mode selector **680** may advantageously logically “OR” the quality and distortion signals **532**, **522**, respectively, and logically “AND” that output with the enable signal **410**, and the comparator output **642**. In such an embodiment, when either the quality signal **532** or the distortion signal **522** indicates less than ideal qualities in the

input IR signal **402**, the mode configuration **211** governs whether the output signals **404**, **406** are triggered. Other embodiments could logically “AND” all the signals to require both the quality signal **532** and the distortion signal **522** to indicate poor signal quality from the sensor before the mode configuration **211** takes over. In still other embodiments, the logical combinations could be part of the mode configuration and the user may control how the signal are combined to determine whether to trigger one or more of the output signals **404**, **406**. Moreover, an artisan will recognize from the disclosure herein a number of logical combinations of input signals that allow the mode configuration **211** to dictate the behavior of a patient monitor with respect to at least the pulse indications when the signal quality is less than ideal.

While variable mode pulse indicator has been described, other embodiments of the present disclosure will be known to those of skill in the art from the descriptions herein. Moreover, those of skill in the art understand that information and signals can be represented using a variety of different technologies and techniques. For example, data, instructions, commands, information, signals, bits, symbols, and chips that can be referenced throughout the above description may be represented by voltages, currents, electromagnetic waves, magnetic fields or particles, optical fields or particles, or any combination thereof.

Those of skill in the art further appreciate that the various illustrative logical blocks, modules, circuits, and algorithm steps described in connection with the embodiments disclosed herein can be implemented as electronic hardware, computer software, or combinations of both. To illustrate this interchangeability of hardware and software, various illustrative components, blocks, modules, circuits, and steps have been described above generally in terms of their functionality. Whether such functionality is implemented as hardware or software depends upon the particular application and design constraints imposed on the overall system. Skilled artisans can implement the described functionality in varying ways for each particular application, but such implementation decisions should not be interpreted as causing a departure from the scope of the present invention.

The various illustrative logical blocks, modules, and circuits described in connection with the embodiments disclosed herein can be implemented or performed with a general purpose processor, a digital signal processor (DSP), an application specific integrated circuit (ASIC), a field programmable gate array (FPGA) or other programmable logic device, discrete gate or transistor logic, discrete hardware components, or any combination thereof designed to perform the functions described herein. A general purpose processor can be a microprocessor, but in the alternative, the processor can be any conventional processor, controller, microcontroller, or state machine. A processor can also be implemented as a combination of computing devices, e.g., a combination of a DSP and a microprocessor, a plurality of microprocessors, one or more microprocessors in conjunction with a DSP core, or any other such configuration.

The steps of a method or algorithm described in connection with the embodiments disclosed herein can be embodied directly in hardware, in a software module executed by a processor, or in a combination of the two. A software module can reside in RAM memory, flash memory, ROM memory, EPROM memory, EEPROM memory, registers, hard disk, a removable disk, a CD-ROM, or other form of storage medium known in the art. A storage medium is coupled to the processor, such that the processor can read information from, and write information to, the storage medium. In the alternative, the storage medium can be integral to the processor. The

processor and the storage medium can reside in an ASIC. The ASIC can reside in a user terminal, physiological monitor and/or sensor. The processor and the storage medium can reside as discrete components in a user terminal, physiological monitor and/or sensor.

Although the foregoing disclosure has been described in terms of certain preferred embodiments, other embodiments will be apparent to those of ordinary skill in the art from the disclosure herein. Additionally, other combinations, omissions, substitutions and modifications will be apparent to the skilled artisan in view of the disclosure herein. Moreover, it is contemplated that various aspects and features of the invention described can be practiced separately, combined together, or substituted for one another, and that a variety of combination and subcombinations of the features and aspects can be made and still fall within the scope of the invention. Furthermore, the systems described above need not include all of the modules and functions described in the preferred embodiments. Accordingly, the present invention is not intended to be limited by the recitation of the preferred embodiments, but is to be defined by reference to the appended claims.

Additionally, all publications, patents, and patent applications mentioned in this specification are herein incorporated by reference to the same extent as if each individual publication, patent, or patent application was specifically and individually indicated to be incorporated by reference.

What is claimed is:

1. A patient monitor receiving a noninvasive optical sensor signal and conditionally outputting an indication of a pulse occurrence, the monitor comprising:

an input signal from said sensor; and

one or more signal processors configured to:

present a caregiver with user-selectable configuration parameters that customize a trigger decision when distortion occurs in said input signal thereby providing said caregiver expected monitor behavior during at least signal distortion;

determine a measure of distortion in said input signal; and determine the trigger decision based on the measured distortion and said user-selectable configuration parameters;

said trigger decision comprising one of providing an indication of pulse occurrences even when the measured signal distortion is high, or providing no output when the signal distortion is high.

2. The patient monitor of claim 1, wherein said one or more signal processors are configured to output said indication as at least a pulse beep.

3. The patient monitor of claim 2, wherein said one or more signal processors are configured to block said pulse beep according to said user-selected configuration parameters.

4. The patient monitor of claim 2, wherein said one or more signal processors are configured to cause said pulse beep to be responsive to a statistical representation of a calculated pulse rate according to said user-selected configuration parameters.

5. The patient monitor of claim 1, wherein said one or more signal processors are configured to output said indication as at least visual display elements.

6. The patient monitor of claim 5, wherein said one or more signal processors are configured to block at least one of said display elements according to said user-selected configuration parameters.

7. The patient monitor of claim 5, wherein said one or more signal processors are configured to cause at least one of said display elements to be responsive to a statistical representation of a calculated pulse rate according to said user-selected configuration parameters.

8. A patient monitor configured to adjust its output to a predetermined expectation, the monitor comprising:

a noninvasive optical sensor outputting a signal having a distortion quality and capable of being processed to find indications of a pulse of a wearer of the sensor;

a memory configured to store user configuration parameters; and

one or more processors including a plurality of modes selectable by the user configuration parameters, said one or more processors configured to:

determine an amount of distortion associated with the signal;

determine a pulse event from the signal; and

determine a trigger decision corresponding to the pulse event based on a selected mode from said plurality of modes and the determined amount of distortion;

wherein in a first mode of said plurality of modes, when said signal includes a sufficiently high amount of distortion, said trigger decision comprises not generating an auditory trigger representing the monitor's determination of a pulse event in said signal as an output to the caregiver, and

wherein in a second mode of said plurality of modes, when said signal includes said sufficiently high amount of distortion, said trigger decision comprises generating an auditory trigger representing the monitor's determination of said pulse event in said signal as an output to the caregiver along with a visual indication that said distortion has been detected.

9. The patient monitor of claim 8, wherein said pulse event corresponds to oxygen supply in the blood.

* * * * *

专利名称(译)	可变模式脉冲指示器		
公开(公告)号	US9192329	公开(公告)日	2015-11-24
申请号	US11/871808	申请日	2007-10-12
[标]申请(专利权)人(译)	AL ALI AMMAR		
申请(专利权)人(译)	AL-ALI AMMAR		
当前申请(专利权)人(译)	Masimo公司		
[标]发明人	AL ALI AMMAR		
发明人	AL-ALI, AMMAR		
IPC分类号	A61B5/02 A61B5/00 A61B5/1455 A61B5/024		
CPC分类号	A61B5/14551 A61B5/0002 A61B5/6826 A61B5/6838 A61B5/02438 A61B5/02427 A61B5/7405 A61B5/742		
代理机构(译)	KNOBBE, MARTENS, 奥尔森 & BEAR LLP		
审查员(译)	德安杰洛, MICHAEL		
优先权	60/851861 2006-10-12 US		
其他公开文献	US20080091092A1		
外部链接	Espacenet USPTO		

摘要(译)

用户可配置的可变模式脉冲指示器为用户提供至少在失真或高噪声事件期间影响指示脉冲发生的输出的能力。例如，当配置为提供或触发脉冲指示输出时，脉冲指示器通过波形分析或脉冲速率的某些统计测量（例如平均脉冲）指定脉冲血氧计导出的光 - 体积描记器波形中每个脉冲的发生率。当配置为阻止输出或不触发脉冲指示输出时，脉冲指示器禁用音频或视觉脉冲发生指示中的一个或多个的输出。输出可用于在显示器上启动可听音“哔”或视觉脉冲指示，例如水平迹线上的垂直尖峰或条形显示器上的相应指示。幅度输出用于指示数据完整性以及计算的饱和度和脉冲率值的相应置信度。幅度输出可以改变脉冲指示器的特性，例如嘟嘟声音量或频率或视觉显示器尖峰的高度。

