



US008341786B2

(12) **United States Patent**
Oexman et al.

(10) **Patent No.:** **US 8,341,786 B2**
(45) **Date of Patent:** **Jan. 1, 2013**

(54) **APPARATUSES AND METHODS PROVIDING VARIABLE SUPPORT AND VARIABLE COMFORT CONTROL OF A SLEEP SYSTEM AND AUTOMATIC ADJUSTMENT THEREOF**

(75) Inventors: **Robert D. Oexman**, Carthage, MO (US); **David B. Scott**, Carthage, MO (US)

(73) Assignee: **Kingsdown, Inc.**, Mebane, NC (US)

(*) Notice: Subject to any disclaimer, the term of this patent is extended or adjusted under 35 U.S.C. 154(b) by 322 days.

(21) Appl. No.: **12/867,690**

(22) PCT Filed: **Nov. 14, 2008**

(86) PCT No.: **PCT/US2008/083620**

§ 371 (c)(1),
(2), (4) Date: **Aug. 13, 2010**

(87) PCT Pub. No.: **WO2009/102361**

PCT Pub. Date: **Aug. 20, 2009**

(65) **Prior Publication Data**

US 2010/0318239 A1 Dec. 16, 2010

Related U.S. Application Data

(60) Provisional application No. 61/028,591, filed on Feb. 14, 2008.

(51) **Int. Cl.**
A61B 5/00 (2006.01)

(52) **U.S. Cl.** 5/713; 5/655.3; 700/301

(58) **Field of Classification Search** 700/301;
5/713, 655.3

See application file for complete search history.

(56) **References Cited**

U.S. PATENT DOCUMENTS

3,462,778 A	8/1969	Whitney
3,786,676 A	1/1974	Korolyshun et al.
4,501,034 A	2/1985	Greenawalt
4,982,466 A	1/1991	Higgins et al.
5,062,169 A	11/1991	Kennedy et al.
5,105,488 A	4/1992	Hutchinson et al.
5,148,706 A	9/1992	Masuda et al.
5,231,717 A	8/1993	Scott et al.
5,848,450 A	12/1998	Oexman et al.
5,987,675 A	11/1999	Kim

(Continued)

FOREIGN PATENT DOCUMENTS

GB 2373189 A 9/2002

(Continued)

OTHER PUBLICATIONS

European Search Report dated Sep. 9, 2011.

(Continued)

Primary Examiner — Michael D Masinick

(74) *Attorney, Agent, or Firm* — Sughrue Mion, PLLC

(57) **ABSTRACT**

An apparatus and method providing variable support and variable comfort control of a sleep system, the apparatus including a sleep support member including: a comfort layer including: a plurality of comfort layer inflatable members; and a comfort layer sensor configured to provide data relating to respective pressures of the comfort layer inflatable members; a data analysis unit configured to analyze data provided by the comfort layer sensor and to generate analyzed comfort layer data; and a control unit configured to control a pressure within each of the respective comfort layer inflatable members using the analyzed comfort layer data.

46 Claims, 7 Drawing Sheets

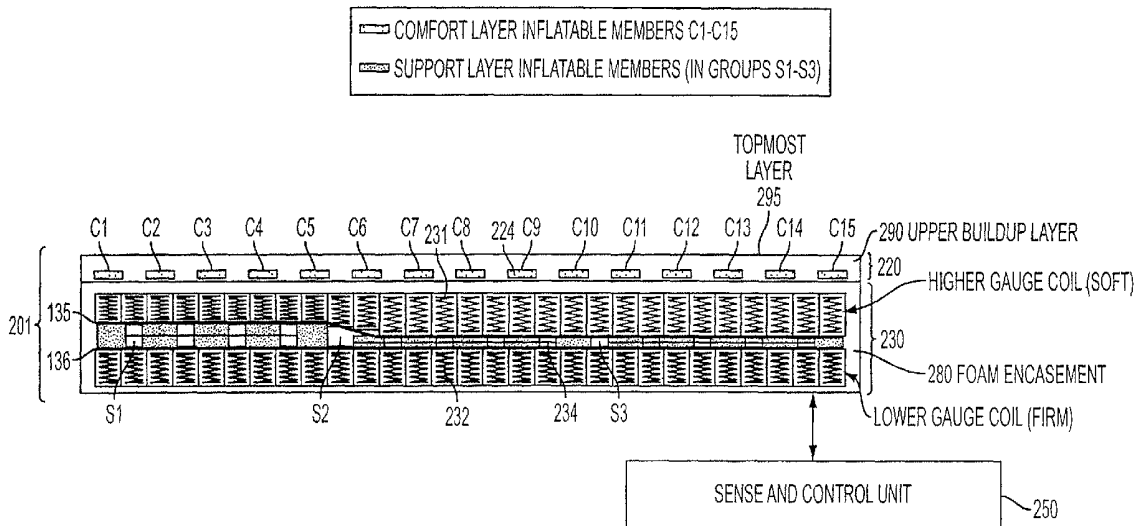

U.S. PATENT DOCUMENTS

6,212,718	B1	4/2001	Stolpmann et al.	
6,220,088	B1	4/2001	Scales et al.	
6,269,505	B1	8/2001	Wilkinson	
6,327,725	B1	12/2001	Veilleux et al.	
6,468,234	B1	10/2002	Van der Loos et al.	
6,560,803	B2*	5/2003	Zur	5/654
6,571,192	B1	5/2003	Hinshaw et al.	
6,585,328	B1	7/2003	Oexman et al.	
6,662,393	B2*	12/2003	Boyd	5/727
6,687,935	B2	2/2004	Reeder et al.	
6,741,950	B2	5/2004	Hinshaw et al.	
6,878,121	B2	4/2005	Krausman et al.	
6,916,236	B2	7/2005	Terpstra	
6,986,182	B2	1/2006	Mossbeck	
6,990,425	B2	1/2006	Hinshaw et al.	
7,127,759	B2	10/2006	Koops	
7,725,967	B2*	6/2010	Simmerer et al.	5/601
RE41,809	E	10/2010	Hinshaw et al.	
2003/0125899	A1	7/2003	Hinshaw et al.	
2004/0139549	A1	7/2004	Mohrekesh et al.	
2004/0177449	A1	9/2004	Wong et al.	
2004/0215416	A1	10/2004	Hinshaw et al.	
2005/0143617	A1	6/2005	Auphan	
2005/0166326	A1*	8/2005	Chaffee	5/655.3
2006/0112489	A1*	6/2006	Bobey et al.	5/655.3
2006/0143831	A1	7/2006	Wu	
2006/0179573	A1	8/2006	Nissen et al.	
2006/0236460	A1	10/2006	Hooper	
2007/0021965	A1	1/2007	Boyd	
2007/0056112	A1	3/2007	Graebe	
2007/0061974	A1	3/2007	Gabbay	
2007/0061976	A1	3/2007	Bazargani	
2007/0086947	A1	4/2007	Boyd	
2007/0199154	A1	8/2007	Escaross	
2007/0238935	A1	10/2007	Boyd	
2008/0244831	A1	10/2008	Kenmochi	
2009/0006027	A1	1/2009	Hinshaw	
2009/0240514	A1	9/2009	Oexman et al.	
2010/0313359	A1	12/2010	Scott et al.	
2010/0317930	A1*	12/2010	Oexman et al.	600/300
2011/0010014	A1	1/2011	Oexman et al.	
2011/0010249	A1	1/2011	Oexman et al.	
2011/0163885	A1*	7/2011	Poulos et al.	340/626

FOREIGN PATENT DOCUMENTS

WO	9732509	A1	9/1997
WO	9963314	A1	12/1999
WO	0051470	A1	9/2000
WO	2005104904	A1	11/2005
WO	2006023479	A2	3/2006
WO	2007053150	A1	5/2007

OTHER PUBLICATIONS

Jacobson, Bert H. et al., "Subjective Rating of Perceived Back Pain, Stiffness and Sleep Quality Following Introduction of Medium-Firm Bedding Systems," Journal of Chiropractic Medicine, Winter 2006, pp. 128-134, vol. 5, No. 4, National University of Health Sciences.

Iber, Conrad et al., The AASM Manual for the Scoring of Sleep and Associated Events: Rules, Terminology and Technical Specifications, 1st ed., 2007, American Academy of Sleep Medicine, Westchester, Illinois.

Diffrient, Niels et al., Humanscale 1/2/3, 1974, The MIT Press, Cambridge.

Diffrient, Niels et al., Humanscale 4/5/6, 1981, The MIT Press, Cambridge.

Tilley, Alvin R., The Measure of Man and Woman, 2002, John Wiley & Sons, New York.

Dement, William C., "History of Sleep Physiology and Medicine," in Principles and Practice of Sleep Medicine, eds. Meir H. Kryger, Thomas Roth, and William C. Dement, 4th Edition, 2005, Elsevier Inc., Philadelphia.

Raymann et al., "Skin Deep: Enhanced Sleep Depth by Cutaneous Temperature Manipulation," Brain: A Journal of Neurology, 2008, pp. 500-513, vol. 131, Oxford University Press.

European Search Report dated Sep. 12, 2011 for EP08872303.6.

Russian Office Action dated Jun. 8, 2011 for RU 2010135586.

Singapore Patent Office Action dated Feb. 27, 2012 for SG 201005897-2.

International Search Report dated Apr. 10, 2012 for PCT/US2011/050122.

* cited by examiner

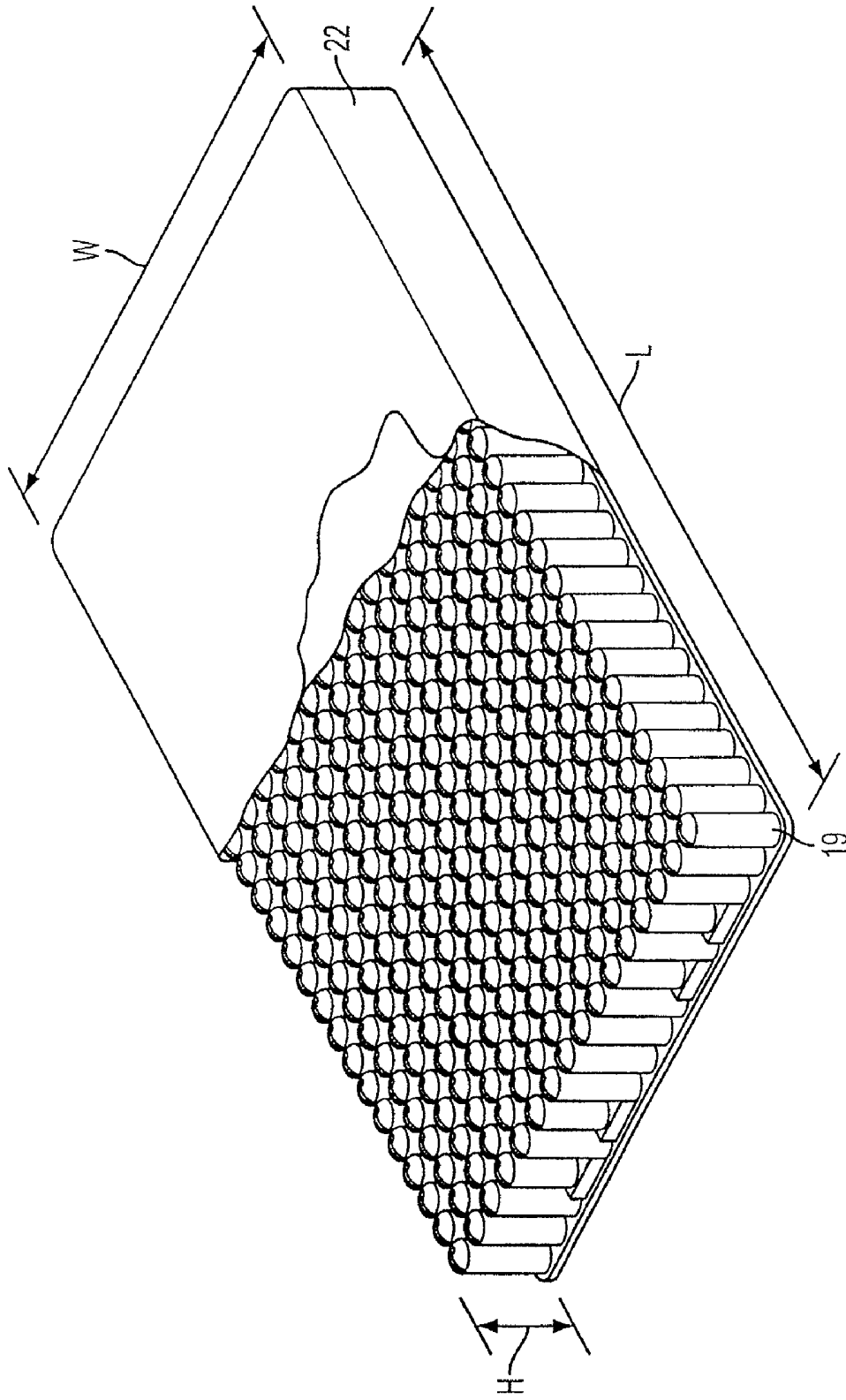

FIG. 1

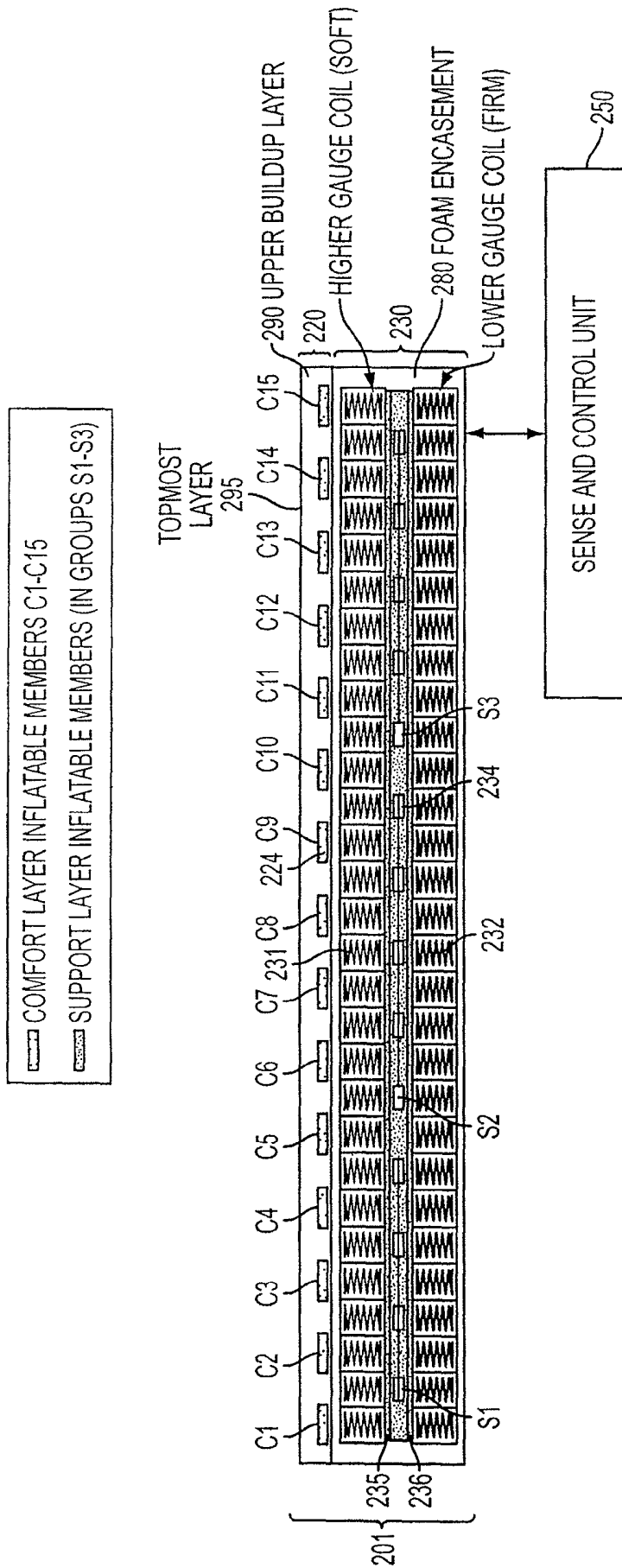

FIG. 2

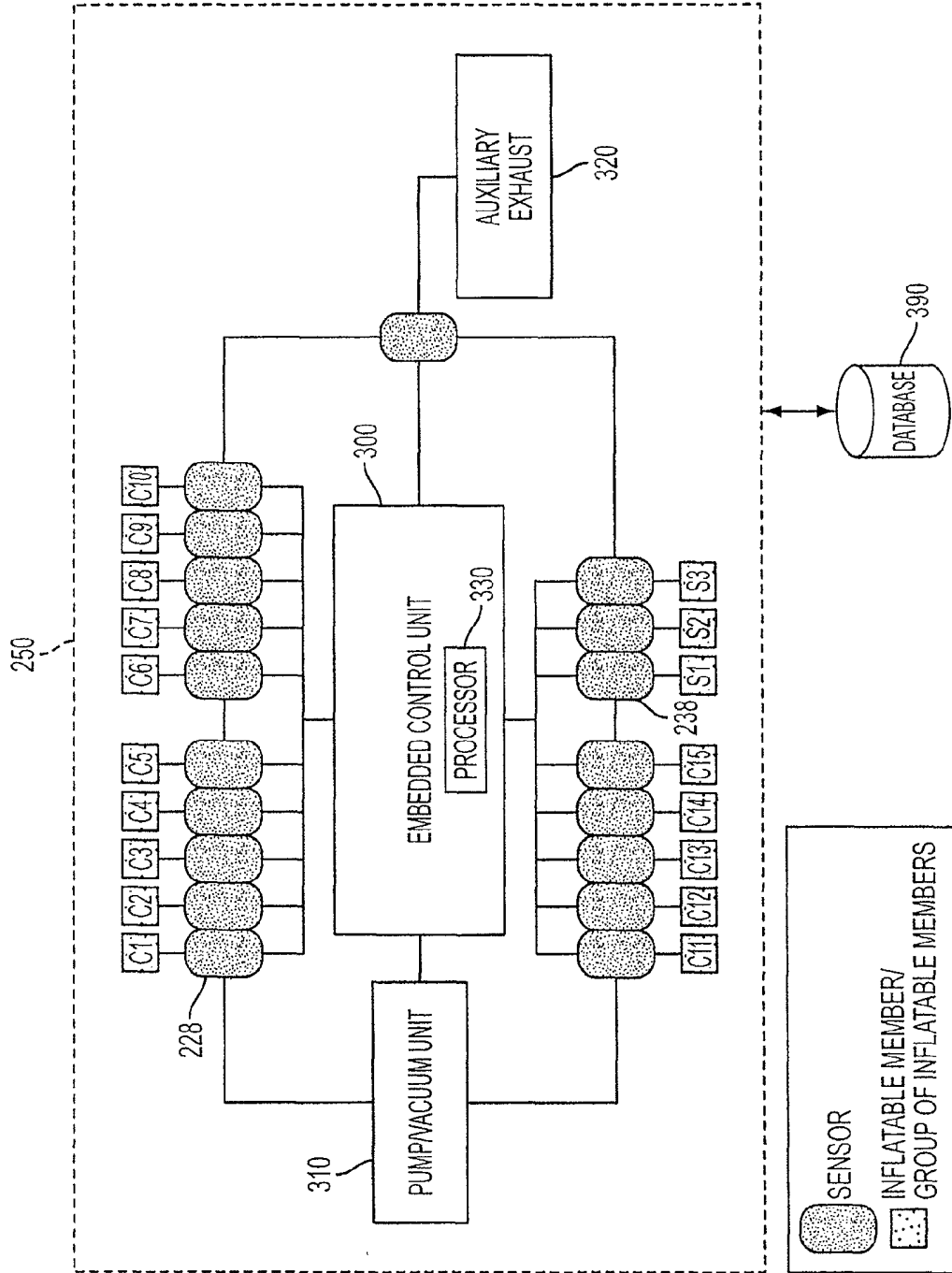

FIG. 3

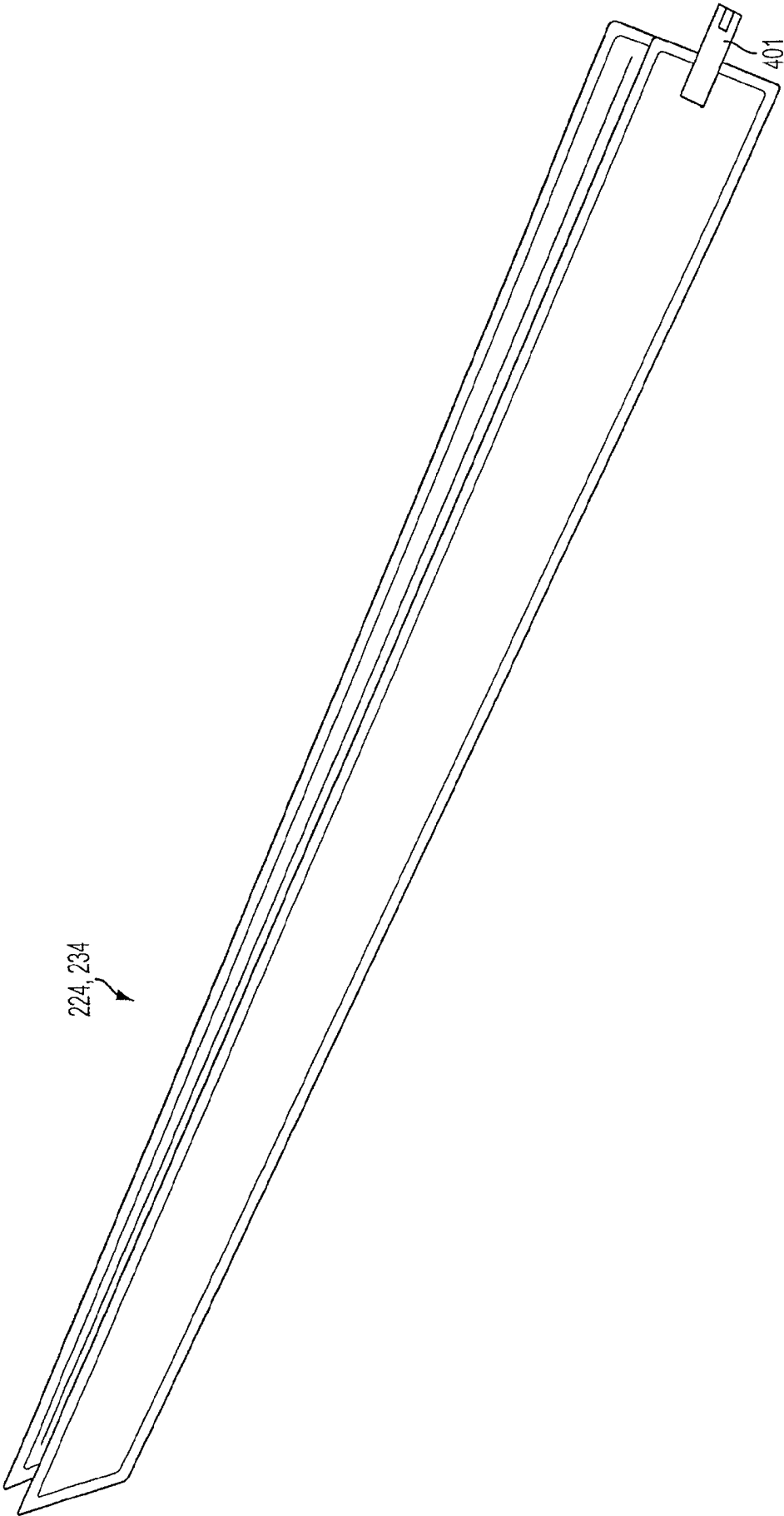

FIG. 4

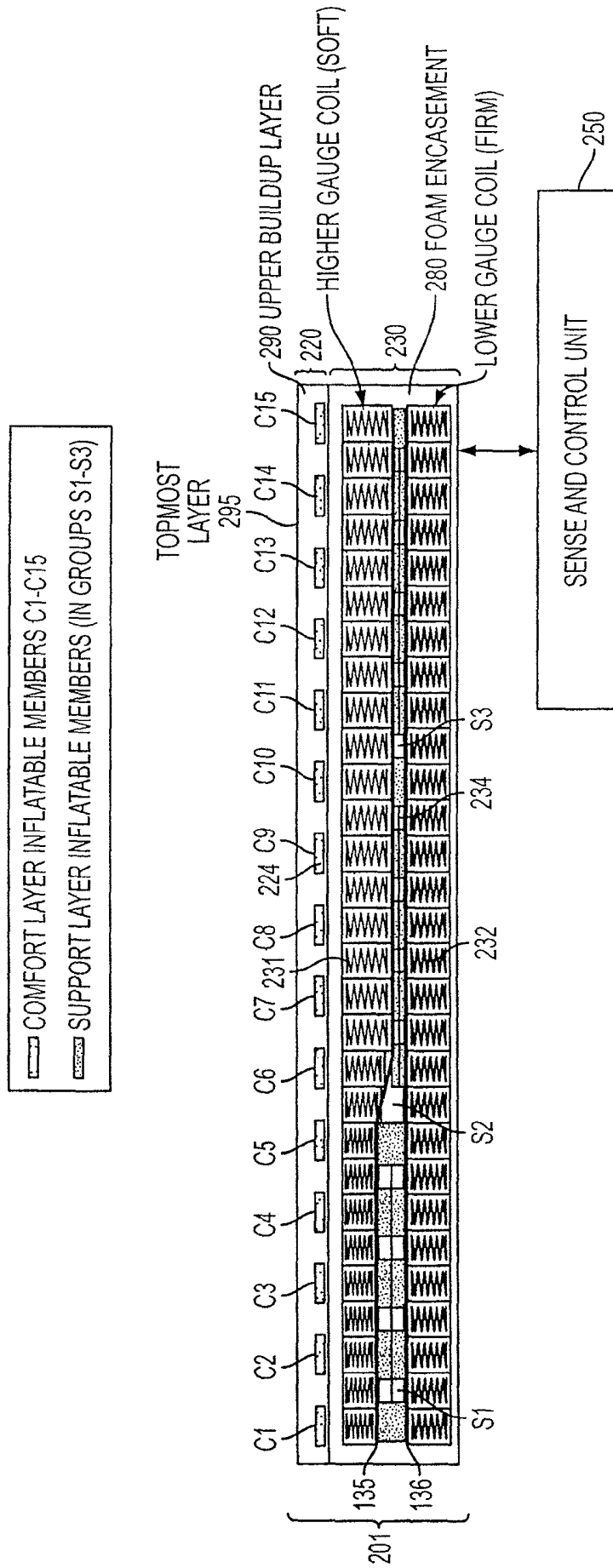

FIG. 5

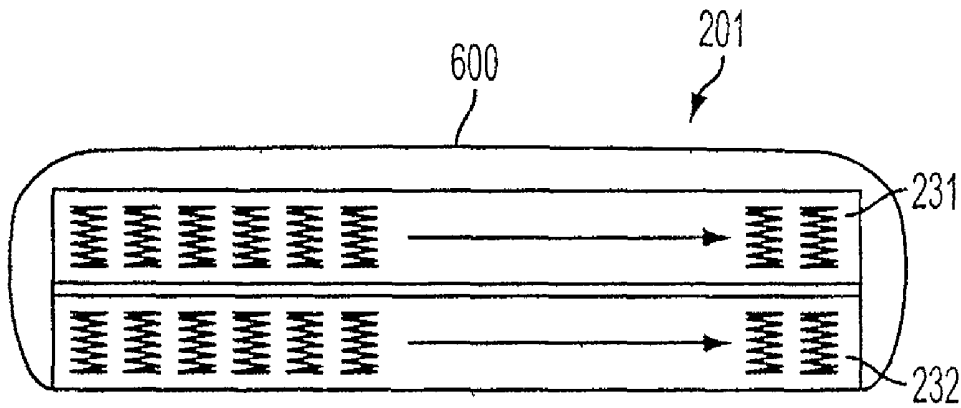

FIG. 6A

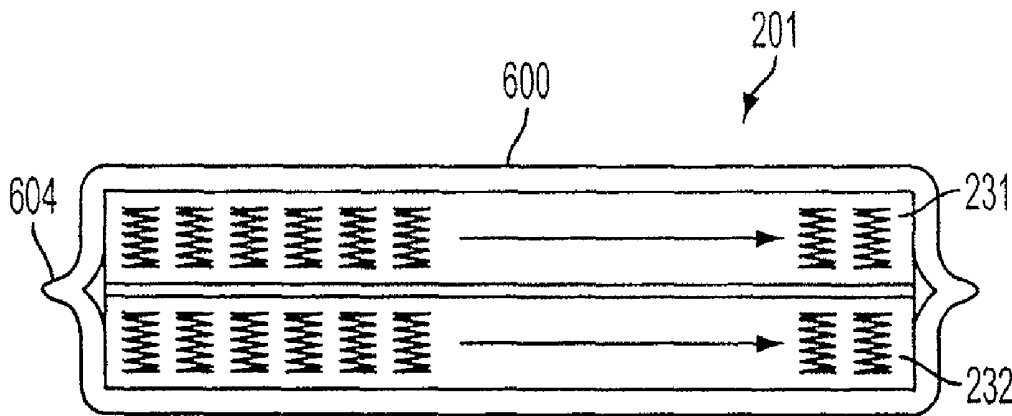

FIG. 6B

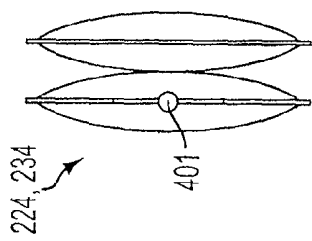

FIG. 7A

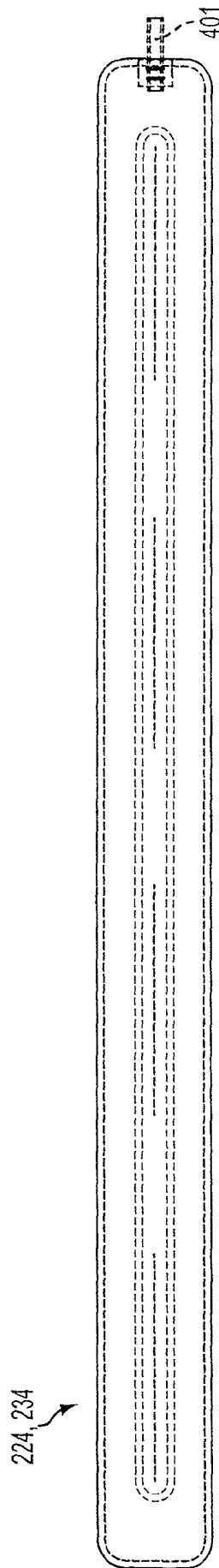

FIG. 7B

**APPARATUSES AND METHODS PROVIDING
VARIABLE SUPPORT AND VARIABLE
COMFORT CONTROL OF A SLEEP SYSTEM
AND AUTOMATIC ADJUSTMENT THEREOF**

CROSS-REFERENCE TO RELATED PATENT
APPLICATION

This application claims priority from U.S. Provisional Patent Application No. 61/028,591, filed on Feb. 14, 2008, in the U.S. Patent and Trademark Office, the disclosure of which is incorporated herein by reference in its entirety.

BACKGROUND

1. Technical Field

Apparatuses and methods consistent with the present invention relate to sleep systems that provide variable control of the support and comfort characteristics of the sleep system. More particularly, these apparatuses and methods provide automatic adjustment of the support and comfort characteristics of a sleep system based on a person's body variances. These apparatuses and methods also provide manual adjustment of the support and comfort characteristics of the sleep system based on support and comfort levels that a person selects.

2. Description of the Related Art

A wide variety of different sleep systems are currently available. Such sleep systems may comprise all aspects of a bedding assembly including, but not limited to, mattresses, box springs, foundation units, bed frames, pillows, mattress pads, linens and, more generally, to any type of sleep product that influences a person's sleep. However, each respective sleep system may be suitable for some persons but not suitable for others persons. The characteristics of a suitable sleep system for a person depend on a number of factors including, but not limited to, the physical attributes of the person (e.g., weight, height, body dimensions, weight distribution, etc.), preferred sleeping positions (e.g., sleeping on back, side, front, etc.), sleeping habits and so on.

Two very different primary components of sleep systems affect a person's overall sleep experience: support and comfort. First, a sleep system delivers support to a person by holding the person in a proper postural alignment, while evenly redistributing the person's body weight across a wide area so as to relieve interface pressure. For example, a mattress may deliver support through the resistance provided by innersprings to the downward force applied due to the person's body weight.

Second, a sleep system delivers comfort to a person's body through the use of comfort materials layered on a top region of the sleep surface. For instance, by layering firming pads and harder, high density foam on top of the innersprings, a mattress can be manufactured to provide varying levels of hardness or firmness. On the other hand, by layering soft materials over the innersprings like convoluted foam, low density foam and/or fiber materials like wool, silk or cashmere, a mattress can be manufactured to provide varying levels of softness or a more plush feel.

The sleep system that is most suitable for a particular person is that sleep system which provides the best possible combination of comfort and support to the person. Further, suitable sleep systems will vary considerably based on a person's physical attributes, sleeping habits, etc.

The number of factors that influence the suitability of a sleep system for a person are vast and interrelated. Thus, the selection of a suitable sleep system can be a complicated and

difficult process for a person. Further, the sleep system that a person selects for themselves based on what sleep system feels most appealing to the person during a showroom testing of the sleep system may not be the most suitable sleep system for the person. Rather, it may require several weeks of sleeping on a given sleep system for a person to determine the long-term suitability of the sleep system. However, prospective sleep system purchasers are generally limited to such brief showroom testing.

Apparatuses and methods for objectively evaluating a person on a sleep system so as to determine the optimal comfort and support characteristics for the person have been developed by the inventors of the present application, as set forth in a related Provisional Application entitled "Apparatus and Methods for Evaluating a Person on a Sleep System," which is incorporated by reference in its entirety. The apparatuses and methods disclosed in the aforementioned related Provisional Application can be employed to (among other things) recommend which of the generic sleep systems that are commercially available will most closely provide the person with the optimal comfort and support characteristics that are determined for the person based on their individual characteristics. Thus, apparatuses and methods disclosed in the aforementioned related Provisional Application (among other things) assist a purchaser in determining the long-term suitability of a sleep system during a brief showroom setting.

However, conventionally, purchasers are typically limited to selecting one of the limited models of generic sleep systems that are commercially available. But, the limited number of generic sleep systems that are commercially available may not precisely provide the optimal comfort and support characteristics that are determined for the person according to the apparatuses and methods of the aforementioned related Provisional Application since generic sleep systems are not custom manufactured to the purchaser's individual characteristics.

Thus, there is a need for a sleep system that can be precisely varied to provide custom determined optimal comfort and support characteristics for a person based on that person's individual characteristics.

Additionally, during the course of a night, a person will experience numerous body variances. For example, among other body variances, the person will exhibit movement and the person's sleeping position will vary throughout the night. The person's heart rate, rate of breathing, state of sleep and sleep quality will also vary. As the person experiences such variances over the course of the night, the optimal sleep system support and comfort characteristics corresponding to the experienced variances will also vary.

However, the support and comfort characteristics of conventional mattresses (even adjustable mattresses) are fixed and do not vary automatically while a person sleeps. Thus, there is a need for a sleep system that can detect and analyze a person's body variances. There is also a need for a sleep system that can automatically adjust the support and comfort characteristics of the sleep system based on such body variances on an immediate basis.

It is also important to recognize that a person's physical attributes (e.g., weight, weight distribution, etc.) and sleeping habits may vary somewhat over time after the person purchases a particular sleep system. For example, the person may gain or lose substantial weight over time, or the person's preferred sleeping position may change. Consequently, the optimal sleep system support and comfort characteristics corresponding to the person's physical attributes may also vary over time. Thus, there is a need for a sleep system that can

analyze such long-term variances and automatically adjust its support and comfort characteristics over time, on a weekly or nightly basis, for example.

Further, a person's support and comfort preferences may vary and, thus, there is a need for a sleep system which allows a person to manually adjust its support and comfort characteristics to the person's liking.

Conventional mattresses have failed to adequately address the above needs and other needs not explicitly mentioned above. For example, a pocketed coil type mattress designed to have an adjustable level of support is described in U.S. Pat. No. 6,986,182 (hereinafter "the '182 patent"), which is incorporated herein by reference in its entirety. The support level adjustment mechanism described regarding that conventional adjustable mattress uses several air bladders that are placed under individual pocketed coils of the mattress.

However, the mattress described in the '182 patent has numerous disadvantages. For example, although the conventional mattress described in the '182 patent can change the amount or level of support, it cannot not adjust for comfort.

Further, according to the mattress described in the '182 patent, each of the air bladders is of a width equal to one of the strings of springs. More particularly, as shown in FIGS. 1, 2 and 4 of the '182 patent, the mattress described therein has a number of coil springs 34, each coil spring being contained within a fabric pocket 32. Each of a plurality of inflatable pneumatic members 50 are arranged underneath a respective row of the pocketed coil springs. The inflatable pneumatic members 50 are connected to an air pump 64 through pneumatic tubes 62 and 60. When the air pump 64 supplies air to the inflatable pneumatic members 50, the inflatable pneumatic members 50 expand. When air is released from the inflatable pneumatic members 50, the inflatable pneumatic members 50 contract.

In the mattress described in the '182 patent, each of the inflatable pneumatic members 50 is placed directly underneath a single row of pocketed coil springs, as clearly shown in FIG. 3 of the '182 patent. Thus, when a respective inflatable pneumatic member 50 is inflated so that it expands, the respective inflatable pneumatic member 50 operates to compress only the single row of pocketed coil springs that is located directly above it.

By compressing the pocketed coil springs, the pocketed coil springs provide firmer support in the specific area of the mattress where the single row of pocketed coil springs is located. When air is released from an inflatable pneumatic member 50, the inflatable pneumatic member 50 compresses, as shown, for example, in FIG. 6 of the '182 patent, by inflatable pneumatic member 50c. This allows the row of pocketed coil springs above the inflatable pneumatic member 50c to decompress, thereby providing less support in those areas of the mattress where the row of pocketed coil springs is located.

However, the mattress described in the '182 patent only provides an adjustable level of support. It does not allow for adjusting a degree of comfort for the person. Further, the mattress described in the '182 patent can only provide a minimal overall increase in support. For example, indentation load deflection tests performed on the mattress described in the '182 patent show an overall increase in support that is a fraction of the illustrative embodiments described herein. The mattress described in the '182 patent also does not automatically adjust the support and comfort characteristics of the sleep system based on the person's body variances.

Thus, there is a need for a sleep system having variable comfort characteristics in addition to an adjustable degree of support provided by the sleep system and for a sleep system

that provides automatic adjustment, as described above. There is also a need for a sleep system in which the force applied by each inflatable member is dispersed among a plurality of rows of coils, rather than being limited to the single row of coils directly above it.

SUMMARY

Aspects of the present invention provide a sleep system having variable control of the support and comfort characteristics of the sleep system. Aspects of the present invention also provide automatic adjustment of the support and comfort characteristics of a sleep system in response to a person's body variances. Further, aspects of the present invention provide manual adjustment of the support and comfort characteristics of a sleep system based on support and comfort levels that a person selects.

An aspect of the present invention provides a sleep system comprising: a sleep support member comprising: a comfort layer comprising: a plurality of comfort layer inflatable members; and a comfort layer sensor configured to provide data relating to respective pressures of the comfort layer inflatable members; a data analysis unit configured to analyze data provided by the comfort layer sensor and to generate analyzed comfort layer data; and a control unit configured to control a pressure within each of the respective comfort layer inflatable members using the analyzed comfort layer data.

Another aspect of the present invention provides a sleep system comprising: a sleep support member comprising: a support layer comprising: a plurality of support layer inflatable members; and a support layer sensor configured to provide data relating to respective pressures of the support layer inflatable members; a data analysis unit configured to analyze data provided by the support layer sensor and to generate analyzed support layer data; and a control unit configured to control a pressure within each of the respective support layer inflatable members using the analyzed support layer data.

Another aspect of the present invention provides a method of controlling a variable sleep support member, the method comprising: determining whether a person is disposed on the sleep support member; if a person is disposed on the sleep support member, then: analyzing data relating to respective pressures of a plurality of comfort layer inflatable members that are arranged in a comfort layer of the sleep support member to generate analyzed comfort layer data; and controlling a pressure within at least one of the comfort layer inflatable members using the analyzed comfort layer data.

BRIEF DESCRIPTION OF THE DRAWINGS

The above and other aspects of the present invention will become more apparent by describing in detail illustrative embodiments thereof with reference to the attached drawings in which:

FIG. 1 illustrates a conventional pocketed coil spring mattress that has multiple rows of pocketed coil springs that extend transversely;

FIG. 2 illustrates a cross-sectional view of a sleep system employing a variable support and comfort control system according to an illustrative embodiment of the present invention;

FIG. 3 illustrates a sense and control unit according to an illustrative embodiment of the present invention;

FIG. 4 illustrates a view of an inflatable member according to an illustrative embodiment of the present invention;

FIG. 5 illustrates a cross-sectional view of a sleep system employing a variable support and comfort control system

wherein a group Si of support layer inflatable members are inflated according to an illustrative embodiment of the present invention;

FIG. 6A illustrates a cross-sectional view of a sleep system employing a variable support and comfort control system having a third force dispersing cover according to an illustrative embodiment of the present invention;

FIG. 6B illustrates a cross-sectional view of a sleep system employing a variable support and comfort control system having a third force dispersing cover according to an illustrative embodiment of the present invention;

FIG. 7A illustrates a side view of one end of an inflatable member according to an illustrative embodiment of the present invention; and

FIG. 7B illustrates a top view of an inflatable member according to an illustrative embodiment of the present invention.

DETAILED DESCRIPTION OF ILLUSTRATIVE EMBODIMENTS

Illustrative embodiments of the invention will now be described in detail with reference to the attached drawings in which like reference numerals refer to like elements.

Aspects of the present invention provide a method and apparatus for adjusting the support and comfort characteristics that a sleep system provides. The support and comfort characteristics of the illustrative sleep system may be adjusted automatically in response to a person's body variances. On the other hand, the support and comfort characteristics of the sleep system may be adjusted manually based on support and comfort levels that a person selects.

FIG. 1 illustrates a conventional pocketed coil spring mattress 22 that has multiple rows of pocketed coil springs 19 that extend transversely. The conventional pocketed coil spring mattress 22 in FIG. 1 is shown having a width "W," a length "L," and a height "H."

In contrast to the conventional mattress shown in FIG. 1, FIG. 2 illustrates a cross-sectional view of a mattress employing a variable support and variable comfort control system according to an illustrative embodiment of the present invention. As shown in FIG. 2, a variable support and variable comfort sleep system 201 comprises a variable comfort layer 220 and a variable support layer 230 that is disposed below the variable comfort layer 220. The variable comfort layer 220 further comprises an upper buildup layer 290 and a top-most layer 295. Further, as shown in FIG. 2, the variable sleep system 201 is connected to a sense and control unit 250.

According to an illustrative embodiment of the present invention, the variable comfort layer 220 and the variable support layer 230 are configured to allow adjustment to (among other things) the two primary components of sleep systems discussed above that affect a person's overall sleep experience, namely, comfort and support. That is, the embodiment shown in FIG. 2 operates to adjust the support characteristics of the variable sleep system 201 and to adjust the comfort characteristics of the variable sleep system 201.

As explained in greater detail below, the variable comfort layer 220 is configured to allow adjustment to the pressure applied to a top region of the variable sleep system 201 at various regions of a person's body. More particularly, the variable comfort layer 220 is configured to allow immediate adjustments to the region of a sleep system that typically delivers comfort to a person's body through the use of comfort layers at a top region of the sleep surface.

On the other hand, the variable support layer 230 is configured to allow adjustment to the pressure applied to a region

of the variable sleep system 201, located below the variable comfort layer 220, at various regions of the person's body. More particularly, the variable support layer 230 is configured to allow immediate adjustments to the region of a sleep system that typically delivers support to a person's body through the resistance provided by the innersprings.

As explained in detail below, by adjusting both the variable comfort layer 220 and the variable support layer 230, it is possible to adjust the variable sleep system 201 so that it provides the best possible combination of comfort and support to the person. Adjustments to the variable support layer 230 may be performed automatically based on body variances of the person, or manually based on the person's comfort preferences.

FIG. 2 shows an illustrative embodiment wherein the variable support layer 230 comprises a layer of upper coils 231 and a layer of lower coils 232. As shown in FIG. 2, the layer of upper coils 231 and the layer of lower coils 232 are enclosed by a foam encasement 280. According to the illustrative embodiment shown in FIG. 2, the layer of upper coils 231 and the layer of lower coils 232 are arranged in rows of coils that extend in a longitudinal direction of the variable sleep system 201 (i.e., the rows of coils extend from the head of the variable sleep system 201 to the foot of the variable sleep system 201). However, the present invention is not limited to this illustrative configuration of coils and the rows of coils comprising the layer of upper coils 231 and the layer of lower coils 232 may extend laterally across the width of the variable sleep system 201 consistent with the present invention. More generally, the rows of coils comprising the layer of upper coils 231 and the layer of lower coils 232 may comprise any arrangement of coils and the present invention is not limited to any specific configuration of coils.

Further, according to one illustrative embodiment, the coils comprising the layer of upper coils 231 and the layer of lower coils 232 comprise what is known in the industry as pocketed coil springs, in which each spring is individually enclosed within a pocket of material. However, the present invention is not limited to a configuration employing pocketed coils and a wide variety of support devices can be used consistent with the present invention, including, but not limited to, layers of plastic based materials or other engineered support systems.

According to the illustrative embodiment shown in FIG. 2, the coils comprising the layer of upper coils 231 are formed of a higher gauge material than the coils comprising the layer of lower coils 232. For example, the coils comprising the layer of upper coils 231 may be formed of 16 gauge wire (i.e., softer coils), whereas the coils comprising the layer of lower coils 232 may be formed of 14 gauge wire (i.e., firmer coils). As such, when force is applied to the top of the variable sleep system 201 (e.g., when a person lies down on the variable sleep system 201), the coils comprising the layer of upper coils 231 compress more easily than the coils comprising the layer of lower coils 232.

A plurality of support layer inflatable members or bladders 234 are disposed between the layer of upper coils 231 and the layer of lower coils 232. As shown in FIG. 2, there are three groups of support layer inflatable members 234, which are respectively referenced as S1, S2 and S3. However, the present invention is not limited to the configuration shown in FIG. 2 and any number of groups of support layer inflatable members 234 may be employed. According to the illustrative embodiment shown in FIG. 2, the support layer inflatable members 234 are pneumatic and are connected to an optional pump/vacuum unit 310 (shown in FIG. 3) via pneumatic tubes. However, the present invention is not limited to this illustrative configuration and other gasses or fluids may be

employed to inflate/deflate the support layer inflatable members 234 to a desired pressure. In particular, the pump/vacuum unit 310 is an optional component that is not a requisite aspect of the present invention.

The support layer inflatable members 234 may be constructed of a variety of materials including, but not limited to plastic, vinyl, neoprene, rubber and the like. According to the illustrative embodiment shown in FIG. 2, the support layer inflatable members 234 extend in a lateral direction across the width of the variable sleep system 201.

As shown in FIGS. 2 and 5, the support layer inflatable members 234 are configured such that, when inflated, the support layer inflatable members 234 apply forces to the layer of upper coils 231 and to the layer of lower coils 232. FIG. 2 illustrates a cross-sectional view of the variable sleep system 201 wherein a group Si of support layer inflatable members 234 are deflated. On the other hand, FIG. 5 illustrates a cross-sectional view of the variable sleep system 201 wherein the group of inflatable members S1 is inflated.

Accordingly, by controlling the inflation/deflation of the support layer inflatable members 234, the support characteristics of the variable sleep system 201 can be adjusted. For example, if the sense and control unit 250 automatically determines, based on the person's body variances, to provide more support for the person's lower back, or receives a manual instruction to do so, then the support layer inflatable members 234 disposed in a region corresponding to the person's lower back can be controlled to further inflate. Consequently, the support layer inflatable members 234 would apply greater forces to certain coils within the layer of upper coils 231 and the layer of lower coils 232 that are disposed in a region corresponding to the person's lower back, causing the aforementioned coils to further compress and, in turn, apply greater support to the person's lower back.

As shown in FIG. 2, the variable sleep system 201 is connected to a sense and control unit 250. A detailed illustration of an illustrative sense and control unit 250 is shown in FIG. 3. As shown in FIG. 3, the sense and control unit 250 comprises a plurality of comfort layer sensors 228, which are respectively associated with the comfort layer inflatable members 224, which are respectively referenced as C1, C2, C3, C4, C5, C6, C7, C8, C9, C10, C11, C12, C13, C14 and C15. The sense and control unit 250 further comprises a plurality of support layer sensors 238, which are respectively associated with the groups S1, S2 and S3 of support layer inflatable members 234.

As further illustrated in FIG. 3, the sense and control unit 250 comprises an embedded control unit 300, a pump/vacuum unit 310 and an auxiliary exhaust unit 320. The embedded control unit further comprises a processor 330. The pump/vacuum unit 310 may be controlled by the embedded control unit 300 to pump or suck air as desired. The auxiliary exhaust unit 320 actively or passively exhausts gas or fluid from the support layer inflatable members 234 and the comfort layer inflatable members 224. According to the illustrative embodiment shown in FIG. 3, the sense and control unit 250 is connected to a database 390.

As shown in FIG. 3, each of the plurality of support layer sensors 238 are connected to a respective group of the support layer inflatable members 234. For example, a group of five support layer inflatable members 234 on the left region of the variable sleep system 201, as shown in FIG. 2, is connected to the support layer sensor S1. Likewise, a group of five support layer inflatable members 234 in the center region of the variable sleep system 201, as shown in FIG. 2, is connected to the support layer sensor S2. Further, a group of five support layer inflatable members 234 on the right side of the variable sleep

system 201, as shown in FIG. 2, is connected to the support layer sensor S3. However, the present invention is not limited to the specific configuration shown in FIGS. 2 and 3 and a wide variety of groupings of the support layer sensors 238 may be used consistent with the present invention. Moreover, each of the plurality of support layer sensors 238 can be connected to a respective one of the support layer inflatable members 234.

Each of the support layer sensors 238 is configured to provide real time measurements relating to the pressure of a respective support layer inflatable member 234 or a respective group of support layer inflatable members 234. As such, when a person is positioned on the variable sleep system 201, measurements relating to the pressure of respective support layer inflatable members 234 can be acquired and analyzed. Using such measurements, a support layer pressure profile of the person can be obtained and used to determine adjustments that would provide the most suitable sleep system support layer characteristics for the person.

According to the illustrative embodiment shown in FIG. 2, the variable support layer 230 comprises fifteen support layer inflatable members 234, but the present invention is not limited to this configuration and a larger or smaller number of support layer inflatable members 234 may be employed consistent with the present invention.

According to the illustrative embodiment illustrated in FIG. 2, each support layer inflatable member 234 is configured to apply forces to a plurality of rows of upper coils 231 and to a plurality of rows of lower coils 232. That is, each support layer inflatable member 234 is aligned with more than one row of coils. Alternatively, each support layer inflatable member 234 can be positioned without regard to the position of the individual coils of the layer of upper coils 231 and the layer of lower coils 232. In one embodiment, the support layer inflatable members 234 may be attached to the coils of the layer of upper coils 231 and to the layer of lower coils 232, for example, by gluing each support layer inflatable member 234 to the coils.

Moreover, a first force dispersing cover 235 may be disposed between the support layer inflatable members 234 and the coils of the layer of upper coils 231. Among other things, the first force dispersing cover 235 facilitates the dispersion of the force applied by each support layer inflatable member 234 among a plurality of rows of upper coils 231. The first force dispersing cover 235 may be comprised of a wide variety of materials including, but not limited to, non-woven fabric, polystyrene, etc.

Likewise, a second force dispersing cover 236 may be disposed between the support layer inflatable members 234 and the layer of lower coils 232. Among other things, the second force dispersing cover 236 facilitates the dispersion of the force applied by each support layer inflatable member 234 among a plurality of rows of lower coils 232.

According to one illustrative embodiment, the first force dispersing cover 235 may be glued to the coils of the layer of upper coils 231 and the second force dispersing cover 236 may be glued to the layer of lower coils 232. By inserting the first and second force dispersing covers 235 and 236 between the coils and the inflatable members, the force applied by expanding each respective inflatable member is spread over a greater area and hence across a greater number of coils. In this illustrative configuration, the first and second force dispersing covers 235 and 236 disperse the force of the inflatable members to achieve a greater effect on the coils over a greater area.

As shown in FIG. 2, an upper buildup layer 290 is disposed above the layer of upper coils 231. The upper buildup layer

290 comprises a plurality of comfort layer inflatable members **224** that are disposed above the layer of upper coils **231** and below a topmost layer **295**. The configuration of each of the respective comfort layer inflatable members **224** is similar to the configuration of the support layer inflatable members **234**, discussed above.

Consistent with the illustrative embodiment depicted in FIG. 2, the comfort layer inflatable members **224** are configured such that, when inflated, the comfort layer inflatable members **224** apply forces to the layer of upper coils **231**, to the upper buildup layer **290** and to the topmost layer **295**. Accordingly, by controlling the inflation/deflation of the comfort layer inflatable members **224**, the comfort characteristics of the variable sleep system **201** (among other things) can be adjusted. For instance, the inflation/deflation of the comfort layer inflatable members **224** can be controlled to change the comfort level of the variable sleep system **201** by making the variable comfort layer **220** either firmer or softer. That is, inflating or deflating a respective one of the comfort layer inflatable members **224** has the effect of compressing or decompressing upper buildup layer **290** and thereby creating a different interface profile (or feel) for the occupant of the variable sleep system **201**.

Thus, if the sense and control unit **250** automatically determines, based on the person's body variances, to make the variable comfort layer **220** firmer under the shoulder region of the person, or receives a manual instruction to do so, then the respective comfort layer inflatable member(s) **224** under the person's shoulder region is/are further inflated. On the other hand, if the sense and control unit **250** automatically determines to make the variable comfort layer **220** softer under the shoulder region of the person, or receives a manual instruction to do so, then the respective comfort layer inflatable member(s) **224** under the person's shoulder region is/are further deflated so as to provide more cushion in those areas.

Additionally, as shown in FIGS. 2 and 3, each of a plurality of comfort layer sensors **228** are connected to a respective one of the comfort layer inflatable members **224**. Each of the comfort layer sensors **228** is configured to provide real time measurements relating to the pressure of a respective comfort layer inflatable member **224**. According to the illustrative embodiment shown in FIGS. 2 and 3, fifteen comfort layer inflatable members **224** are connected to fifteen comfort layer sensors **228**. However, the present invention is not limited to this configuration and a larger or smaller number of comfort layer sensors **228** may be employed consistent with the present invention.

Moreover, as shown in FIG. 2, each of the comfort layer inflatable members **224** is aligned with a respective one of the support layer inflatable members **234**, however, such alignment is not necessary and illustrative embodiments of the invention may comprise configurations of comfort layer inflatable member **224** and support layer inflatable members **234** that are not aligned.

Also, according to the illustrative embodiment shown in FIG. 2, the comfort layer inflatable members **224** need not be aligned with a respective row of the upper coils **231**. Indeed, a respective comfort layer inflatable member **224** may be aligned with more than one of the rows of upper coils **231**. Alternatively, the comfort layer inflatable members **224** can be positioned without regard to the position of the individual upper coils **231**.

Importantly, when a person is positioned on the variable sleep system **201**, measurements relating to the pressure of respective comfort layer inflatable members **224** can be acquired and analyzed. Using such measurements, a comfort layer pressure profile of the person can be obtained and used

to determine adjustments that would provide the most suitable sleep system comfort layer characteristics for the person.

Although the illustrative embodiment shown in FIG. 2 comprises a variable comfort layer **220** and a variable support layer **230**, the present invention is not limited to this configuration. In fact, illustrative embodiments of the present invention may include only the variable comfort layer **220**, or only the variable support layer **230**.

Additionally, according to illustrative embodiments of the present invention, as shown in FIGS. 6A and 6B, the variable sleep system **201** may comprise a third force dispersing cover **600**, which is wrapped around the layer of upper coils **231** and the layer of lower coils **232**. According to the illustrative embodiment shown in FIGS. 6A and 6B, the third force dispersing cover **600** extends the length of the variable sleep system **201**, but does not extend over the head or the foot of the variable sleep system **201**. As shown in FIGS. 6A and 6B, the third force dispersing cover **600** is, for illustrative purposes, shown as loosely surrounding the layer of upper coils **231** and the layer of lower coils **232**. However, illustrative embodiments of the present invention may comprise a third force dispersing cover **600** that is tightly wrapped around the layer of upper coils **231** and the layer of lower coils **232**. Among other things, the third force dispersing cover **600** disperses the forces applied by the upper coils **231** and the layer of lower coils **232** over a greater area of the foam encasement layer **280** (shown in FIGS. 2 and 5) and, thus, helps to prevent a crowning effect that may occur at the top surface of the variable sleep system **201**.

According to the illustrative embodiment shown in FIG. 6A, the third force dispersing cover **600** is attached to a bottom border of the variable sleep system **201** (e.g., border wire) and does not extend below the layer of lower coils **232**.

Alternatively, according to the illustrative embodiment shown in FIG. 6B, the third force dispersing cover **600** extends below the layer of lower coils **232**. Further, as shown in FIG. 6B, two opposing portions of the third force dispersing cover **600** are attached together at attachment portion **604**. For example, the two opposing portions of the third force dispersing cover **600** may be attached via an ultrasonic weld, sewing, staples, etc. However, the present invention is not limited to the two exemplary configurations shown in FIGS. 6A and 6B and the third force dispersing cover **600** may assume a wide variety of configurations.

According to an illustrative embodiment, the variable comfort layer **220** may be configured to comprise a plurality of different zones, each zone providing respective comfort characteristics. For instance, the variable comfort layer **220** may comprise seven different comfort zones, wherein each comfort zone comprises at least one comfort layer inflatable member **224** and wherein the seven different comfort zones are not equal in size. On the other hand, the variable support layer **230** may comprise three different support zones, wherein each support zone comprises at least one support layer inflatable member **234**, wherein the three different support zones are not equal in size.

Consistent with the present invention, the support layer sensors **238** and the comfort layer sensors **228** provide the ability to measure a wide variety of data. For example, when a person is positioned on the variable sleep system **201**, data provided by the support layer sensors **238** and the comfort layer sensors **228** can be analyzed to determine, among other things, the person's weight, weight distribution, body position, breathing rate, heart rate, state of sleep, etc. Further, such data can be acquired and analyzed over time to determine a variety of body variances of the person while the person sleeps.

As shown in FIGS. 2 and 3, the support layer inflatable members 234, the support layer sensors 238, the comfort layer inflatable members 224, and the comfort layer sensors 228 are all connected to the sense and control unit 250. By using the information collected by the sense and control unit 250, the general body dimensions and weight distribution (among other things) of a person disposed on the variable sleep system 201 can be statistically predicted. The processor 330 can use these statistically predicted values to determine adjustments to the combinations of zoned support and zoned comfort provided by the variable sleep system 201 that are needed to produce a healthy sleep system. More generally, the processor 330 can measure and analyze the effect of the person's body on various points on the variable comfort layer 220 and the variable support layer 230 and can record this measurement data over time.

Thus, according to one illustrative embodiment, a person positions themselves on the variable sleep system 201 and the processor 330 measures and analyzes the effect of the person's body on various points on the variable comfort layer 220 and the variable support layer 230. Using such measurement data, the processor 330 then determines the optimal adjustments to the support layer inflatable members 234 and comfort layer inflatable members 224 that would provide the person with the best combination of zoned support and zoned comfort. The sense and control unit 250 then adjusts the support layer inflatable members 234 and comfort layer inflatable members 224 to their respective determined optimal levels, thus providing the variable sleep system 201 with optimal support and comfort characteristics.

Further, according to another illustrative embodiment, the processor 330 records measurement data regarding the effect of the person's body on various points on the variable comfort layer 220 and the variable support layer 230 over time. By analyzing such data, the processor 330 can detect a wide variety of body variances of the person and can determine optimal adjustments to the support layer inflatable members 234 and comfort layer inflatable members 224 based on such detected variances.

According to one illustrative embodiment, the sense and control unit 250 can detect and provide immediate automatic adjustments to the comfort layer inflatable members 224 and the support layer inflatable members 234 based on measurements taken about the person during sleep, as to continuously provide the variable sleep system 201 with custom-determined optimal comfort and support characteristics, respectively. In particular, during the course of a night, the sense and control unit 250 can detect and analyze a wide variety of body variances that a person experiences including, but not limited to, a person's weight distribution, body position, breathing rate, heart rate, state of sleep, sleep quality etc. Thus, the sense and control unit 250 can automatically adjust both the comfort layer inflatable members 224 and the support layer inflatable members 234 in immediate response to such body variances so as to continuously provide optimal support and comfort characteristics to the person throughout the night.

For example, if based on measurements regarding changes in the person's sleep quality, the sense and control unit 250 determines that additional support is needed in a particular zone of the variable sleep system 201 to improve sleep quality, then the support layer inflatable members 234 in that zone can be adjusted.

Or, for instance, the sense and control unit 250 can determine that a person has rolled over in their sleep to a new sleeping position (e.g., the person has rolled from their back to their side) and that, as a result, additional support is needed in the person's hip area. Accordingly, the sense and control

unit 250 can then adjust designated support layer inflatable member(s) 234 corresponding to the region of the person's hip area by increasing the pressure within those designated support layer inflatable member(s) 234. Consequently, the designated support layer inflatable member(s) 234 would expand, causing the coil(s) of the layer of upper coils 231 located above the designated support layer inflatable member(s) 234 to compress. This, in effect, causes the coil(s) corresponding to the region of the person's hip area to be biased by the inflation of the designated support layer inflatable member(s) 234. Accordingly, additional support would be provided in that area of the variable sleep system 201 that corresponds to the person's hip area.

In addition to providing immediate automatic adjustments like those examples discussed above, the sense and control unit 250 can also measure and analyze a person's body variances (e.g., gains or losses in weight, changes in weight distribution, etc.) and sleeping habits over an extended period of time. Hence, the sense and control unit 250 can adjust the comfort layer inflatable members 224 and the support layer inflatable members 234 in response to such long-term variances so as to continuously provide optimal support and comfort characteristics to the person over an extended period.

By way of illustration, suppose a person gradually gains substantial weight during the years subsequent to their purchase of the sleep system 201. In such a case, the sense and control unit 250 would detect, measure and analyze this gradual variance in weight over time. Based on such an analysis, the sense and control unit 250 might, for example, then determine that additional support is required, throughout the entire support layer 230, to compensate for the person's weight gain and to thereby provide the variable sleep system 201 with the optimal support characteristics for the person. Accordingly, as the person gains weight over time, the sense and control unit 250 would automatically control each of the support layer inflatable members 234 to further inflate, as necessary, to provide the optimal support characteristics for the person corresponding to their gradual variance in weight.

Consistent with the present invention, the optimal pressure levels for each of the respective comfort layer inflatable members 224 and support layer inflatable members 234 and at which the variable sleep system 201 provides optimal comfort and support characteristics to the person can be determined in a number of ways. For example, such optimal pressure levels can be determined by analyzing data obtained by observing a plurality of different persons of varying physical attributes (e.g., persons of different heights, weights, weight distributions, waist widths, shoulder widths, etc.) as they are positioned on a variety of different sleep systems having different comfort and support characteristics, in a variety of different sleeping positions and by recording observed data in the database 390. By recording such observed data in the database 390, along with which particular comfort and support characteristics provide each respective person with the best support (e.g., spinal alignment, etc.) and comfort characteristics (e.g., lowest amount of interface pressure, etc.) a correspondence between particular physical attributes of persons and suitable comfort and support characteristics can be established and stored in the database 390.

Examples of apparatuses and methods for objectively evaluating a person on a sleep system so as to determine the optimal comfort and support characteristics for the person have been developed by the inventors of the present application, as set forth in the aforementioned related Provisional Application. However, such apparatuses and examples are merely examples and the present invention is not limited to these examples.

According to one illustrative embodiment, the optimal pressure levels of the support layer inflatable members 234 and comfort layer inflatable members 224 for a person can be calculated as set forth in the aforementioned related Provisional Application using the test bed disclosed therein. Such calculations can then be used to provide the most suitable variable support and variable comfort settings to which the variable sleep system 201 can be adjusted. For example, the calculations from the aforementioned test bed can be provided to and stored in the database 390 in a variety of ways including, but not limited to, transfer via wireless or wired communication, transfer via storage media, manual data input, etc.

That is, by way of illustration, a prospective sleep system purchaser could visit a sleep system showroom where an evaluation of the person on a sleep system can be performed according to the aforementioned related Provisional Application. As a result of this evaluation, the prospective sleep system purchaser would be provided with optimal variable support and variable comfort settings to be transferred to a variable sleep system 201 in the purchaser's home. Thus, the variable sleep system 201 would adjust the support layer inflatable members 234 and comfort layer inflatable members 224 to the optimal pressure levels so as to provide the optimal support and comfort characteristics to the purchaser.

According to an illustrative embodiment of the present invention, a person can manually input body data to the sense and control unit 250, including, but not limited to, data such as the person's height, weight, body size, etc. Using such manually inputted body data, the processor 330 then determines the optimal adjustments to the support layer inflatable members 234 and comfort layer inflatable members 224 that would provide the person with the best combination of zoned support and zoned comfort. The sense and control unit 250 then adjusts the support layer inflatable members 234 and comfort layer inflatable members 224 to their respective determined optimal levels, thus providing the variable sleep system 201 with optimal support and comfort characteristics using the manually inputted body data.

In addition to the support and comfort characteristics of the variable sleep system 201 being automatically adjustable, as described above, a person could also manually control the support and comfort characteristics of the variable sleep system 201 based on support and comfort levels that the person selects. For example, if a person desired to make the variable sleep system 201 feel firmer under the person's shoulders, then the person could control the comfort layer inflatable member(s) 224 corresponding to the person's shoulder region to be further inflated by increasing the pressure of the respective comfort layer inflatable member(s) 224. When the respective comfort layer inflatable member(s) 224 corresponding to the person's shoulder region inflate and expand, the respective comfort layer inflatable member(s) 224 cause the coils of the layer of upper coils 231 below to compress and cause the region of the upper buildup layer 290 above to compress. Consequently, the variable sleep system 201 would apply greater contact pressure to the region corresponding to the person's shoulders (i.e., this region would feel firmer).

Conversely, if the person desired to make the variable sleep system 201 feel softer, then the person could control the sense and control unit 250 to reduce the pressure of certain comfort layer inflatable member(s) 224 (e.g., by releasing air from certain comfort layer inflatable member(s) 224) so as to cause the variable sleep system 201 to apply less contact pressure to the person in those areas (i.e. those areas would feel softer and have more cushion).

Although the above example describes manual adjustments to the comfort characteristics of the variable sleep system 201, a person can also manually adjust the support characteristics of the variable sleep system 201 in an analogous manner. Indeed, in contrast to conventional devices like the mattress described in the '182 patent (which only provides an overall increase in support of less 15%), indentation load deflection tests show that illustrative embodiments of the present invention exhibit an overall increase in support of more than 100%.

Furthermore, although the illustrative embodiments described above relate to varying the support and comfort characteristics of the variable sleep system 201 to provide the optimal support and comfort for a single person, the present invention can also be employed to vary the support and comfort characteristics of the variable sleep system 201 to provide the optimal support and comfort for a person and their sleeping partner. According to one illustrative embodiment, the variable sleep system 201 may comprise two separate variable surfaces so that optimal support and comfort characteristics can be provided to two persons at the same time, even if the two persons have significantly different physical attributes. Thus, apparatuses and methods consistent with the present invention also provide automatic adjustment of the support and comfort characteristics of a sleep system comprising two variable surfaces in response to body variances of two persons, respectively. Further, aspects of the present invention provide manual adjustment of the support and comfort characteristics of a sleep system comprising two variable surfaces based on support and comfort levels that two persons select, respectively.

FIG. 4 illustrates a view of an inflatable member 224 or 234 according to an illustrative embodiment of the present invention. Although one illustrative shape and configuration of the inflatable member is shown in FIG. 4, the inflatable members 224 and 234 may assume other shapes and configurations consistent with the present invention. Further, the comfort layer inflatable members 224 may assume shapes and/or configurations that are different from the shapes and/or configurations of the support layer inflatable members 234. As shown in FIG. 4, each of the inflatable members comprises a valve 401.

FIG. 7A illustrates a side view of one end of an inflatable member 224 or 234 according to an illustrative embodiment of the present invention. FIG. 7B illustrates a top view of an inflatable member 224 or 234 according to an illustrative embodiment of the present invention.

The method of controlling the support and comfort of a mattress according to an illustrative embodiment of the invention can also be embodied as computer readable codes on a computer readable recording medium. The computer readable recording medium can be any data storage device that can store data which can be read by a computer or a computer system. Examples of the computer readable recording medium include, but are not limited to, read-only memory (ROM), random-access memory (RAM), CD-ROMs, magnetic tapes, floppy disks, and optical data storage devices. The computer readable recording medium can also be distributed over network coupled computer systems so that the computer readable code is stored and executed in a distributed fashion.

While the present invention has been particularly shown and described with reference to illustrative embodiments thereof, it will be understood by those of ordinary skill in the art that various changes in form and details may be made therein without departing from the spirit and scope of the invention as defined by the appended claims. The illustrative embodiments should be considered in a descriptive sense

only and not for purposes of limitation. Therefore, the scope of the invention is defined not by the detailed description of the invention but by the claims set forth in the related non-provisional application and all differences within the scope will be construed as being included in the present invention. 5

What is claimed is:

1. A sleep system comprising:
 - a sleep support member comprising:
 - a comfort layer comprising:
 - a plurality of comfort layer inflatable members; and
 - a comfort layer sensor configured to provide data relating to respective pressures of the comfort layer inflatable members;
 - a data analysis unit configured to analyze data provided by the comfort layer sensor and to generate analyzed comfort layer data; and
 - a control unit configured to control a pressure within each of the respective comfort layer inflatable members using the analyzed comfort layer data,
 - wherein the sleep system further comprises a support layer comprising:
 - a plurality of support layer inflatable members; and
 - a support layer sensor configured to provide data relating to respective pressures of the support layer inflatable members;
 - wherein the data analysis unit is configured to analyze data provided by the support layer sensor and to generate analyzed support layer data; and
 - wherein the control unit is configured to control a pressure within each of the respective support layer inflatable members using the analyzed support layer data.
2. The sleep system according to claim 1, wherein the comfort layer inflatable members are pneumatic; and wherein the comfort layer inflatable members are connected to a pump/vacuum unit.
3. The sleep system according to claim 2, wherein the comfort layer sensor is configured to provide real time measurements.
4. The sleep system according to claim 1, wherein the comfort layer inflatable members are configured such that the pressure within each of the respective comfort layer inflatable members can be controlled using a fluid.
5. The sleep system according to claim 1, wherein the comfort layer inflatable members extend in a lateral direction across a width of the sleep support member.
6. The sleep system according to claim 1, wherein the control unit is configured to control variation of at least one of comfort characteristics and support characteristics of the comfort layer by controlling the pressure within each of the respective comfort layer inflatable members.
7. The sleep system according to claim 6, wherein the data analysis unit is configured to analyze data provided by the comfort layer sensor to generate a pressure profile of a person disposed on the sleep support member.
8. The sleep system according to claim 1, wherein the data analysis unit is configured to analyze data provided by the comfort layer sensor relating to body variances of a person disposed on the sleep support member.
9. The sleep system according to claim 1, wherein the data analysis unit is configured to determine an adjustment to a pressure of at least one of the comfort layer inflatable members that would cause the comfort layer to provide at least one of more suitable comfort characteristics and more suitable support characteristics for the person.
10. The sleep system according to claim 1, wherein the support layer is disposed below the comfort layer.

11. The sleep system according to claim 1, wherein the support layer comprises:

- a layer of upper coils; and
- a layer of lower coils,

wherein the support layer inflatable members are disposed below the layer of upper coils and above the layer of lower coils.

12. The sleep system according to claim 11, wherein the sleep support member further comprises a first force dispersing cover disposed above the support layer inflatable members and below the upper coils.

13. The sleep system according to claim 12, wherein the sleep support member further comprises a second force dispersing cover disposed below the support layer inflatable members and above the lower coils.

14. The sleep system according to claim 13, wherein the sleep support member further comprises a third force dispersing cover, which surrounds the layer of upper coils and the layer of lower coils.

15. The sleep system according to claim 11, wherein the sleep support member further comprises an encasement member configured to encase the layer of upper coils and the layer of lower coils.

16. The sleep system according to claim 11, wherein the upper coils and the lower coils comprise pocketed coil springs.

17. The sleep system according to claim 11, wherein the upper coils are formed of a higher gauge material than a material of which the lower coils are formed.

18. The sleep system according to claim 1, wherein the support layer inflatable members are pneumatic; and wherein the support layer inflatable members are connected to a pump/vacuum unit.

19. The sleep system according to claim 1, wherein the support layer inflatable members are configured such that the pressure within each of the respective support layer inflatable members is controlled using a fluid.

20. The sleep system according to claim 1, wherein the support layer inflatable members extend in a lateral direction across a width of the sleep support member.

21. The sleep system according to claim 1, wherein the support layer inflatable members are configured such that, if inflated, the support layer inflatable members apply a force to at least one of the upper coils and at least one of the lower coils.

22. The sleep system according to claim 1, wherein the control unit is configured to control variation of at least one of comfort characteristics and support characteristics of the support layer by controlling the pressure within each of the respective support layer inflatable members.

23. The sleep system according to claim 22, wherein the data analysis unit is configured to analyze data provided by the support layer sensor relating to body variances of a person disposed on the sleep support member.

24. The sleep system according to claim 23, wherein the control unit is configured to control variation of the at least one of comfort characteristics and support characteristics of the support layer using the analyzed support layer data.

25. The sleep system according to claim 22, wherein the data analysis unit is configured to analyze data provided by at least one of the comfort layer sensor and the support layer sensor to generate a pressure profile of a person disposed on the sleep support member.

26. The sleep system according to claim 25, wherein the data analysis unit is configured to determine an adjustment to a pressure of at least one of the comfort layer inflatable members and the support layer inflatable members that would

cause at least one of the comfort layer and the support layer to provide at least one of more suitable comfort characteristics and more suitable support characteristics for the person.

27. The sleep system according to claim 1, wherein the support layer sensor is configured to provide real time measurements.

28. The sleep system according to claim 1, wherein the data analysis unit is configured to analyze the data provided by the comfort layer sensor, if a person is disposed on the sleep support member, to determine at least one of the person's weight, the person's weight distribution, the person's body position, the person's breathing rate, the person's heart rate and the person's state of sleep.

29. The sleep system according to claim 1, wherein a width of each respective support layer inflatable member is greater than a diameter of each upper coil adjacent to the respective support layer inflatable member.

30. The sleep system according to claim 29, wherein a width of each respective support layer inflatable member is greater than a diameter of each lower coil adjacent to the respective support layer inflatable member.

31. A method of controlling a variable sleep support member, the method comprising:

determining whether a person is disposed on the sleep support member;

if a person is disposed on the sleep support member, then: analyzing data relating to respective pressures of a plurality of comfort layer inflatable members that are arranged in a comfort layer of the sleep support member to generate analyzed comfort layer data;

controlling a pressure within at least one of the comfort layer inflatable members using the analyzed comfort layer data;

analyzing data relating to respective pressures of a plurality of support layer inflatable members that are arranged in a support layer of the sleep support member to generate analyzed support layer data; and

controlling a pressure of at least one of the support layer inflatable members using the analyzed support layer data.

32. The method according to claim 31, wherein the data relating to respective pressures of the plurality of comfort layer inflatable members is sensed with a comfort layer sensor.

33. The method according to claim 31, wherein the controlling a pressure within at least one of the comfort layer inflatable members using the analyzed comfort layer data is performed automatically.

34. The method according to claim 31, wherein the controlling a pressure within at least one of the comfort layer inflatable members using the analyzed comfort layer data is performed using a gas pump/vacuum unit.

35. The method according to claim 31, wherein the controlling a pressure within at least one of the comfort layer inflatable members using the analyzed data is performed using a fluid.

36. The method according to claim 31, wherein the controlling a pressure within at least one of the comfort layer inflatable members using the analyzed comfort layer data is performed so as to vary at least one of comfort characteristics and support characteristics of the comfort layer.

37. The method according to claim 36, wherein the analyzing data relating to respective pressures of the plurality of comfort layer inflatable members comprises generating a pressure profile of the person.

38. The method according to claim 31, wherein the analyzing data relating to respective pressures of the plurality of comfort layer inflatable members further comprises analyzing data relating to body variances of the person.

39. The method according to claim 31, wherein the analyzing data relating to respective pressures of the plurality of comfort layer inflatable members comprises analyzing real time data relating to respective pressures of the plurality of comfort layer inflatable members.

40. The method according to claim 31, wherein the analyzing data relating to respective pressures of the plurality of comfort layer inflatable members comprises determining an adjustment to a pressure of at least one of the comfort layer inflatable members that would cause the comfort layer to provide at least one of more suitable comfort characteristics and more suitable support characteristics for the person.

41. The method according to claim 31, wherein the data relating to respective pressures of the plurality of support layer inflatable members is sensed with a support layer sensor.

42. The method according to claim 31, wherein the controlling a pressure within at least one of the support layer inflatable members using the analyzed support layer data is performed automatically.

43. The method according to claim 31, wherein the controlling a pressure of at least one of the support layer inflatable members using the analyzed support layer data is performed so as to vary at least one of comfort characteristics and support characteristics of the support layer.

44. The method according to claim 31, wherein the analyzing data relating to respective pressures of the plurality of support layer inflatable members further comprises analyzing data relating to body variances of the person.

45. The method according to claim 31, wherein the analyzing data relating to respective pressures of the plurality of support layer inflatable members comprises analyzing real time data relating to respective pressures of the plurality of support layer inflatable members.

46. The method according to claim 31, wherein the analyzing data relating to respective pressures of the plurality of support layer inflatable members comprises determining an adjustment to a pressure of at least one of the support layer inflatable members that would cause the support layer to provide at least one of more suitable comfort characteristics and more suitable support characteristics for the person.

* * * * *

UNITED STATES PATENT AND TRADEMARK OFFICE
CERTIFICATE OF CORRECTION

PATENT NO. : 8,341,786 B2
APPLICATION NO. : 12/867690
DATED : January 1, 2013
INVENTOR(S) : Robert D. Oexman and David B. Scott

Page 1 of 1

It is certified that error appears in the above-identified patent and that said Letters Patent is hereby corrected as shown below:

In the Claims

Column 15, Line 60: In Claim 9, delete "claim 1" and insert --claim 8--

Column 16, Line 41: In Claim 21, delete "claim 1" and insert --claim 11--

Signed and Sealed this
Sixth Day of January, 2015

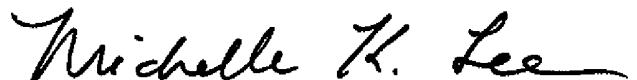

Michelle K. Lee
Deputy Director of the United States Patent and Trademark Office

专利名称(译)	提供睡眠系统的可变支撑和可变舒适控制以及其自动调节的装置和方法		
公开(公告)号	US8341786	公开(公告)日	2013-01-01
申请号	US12/867690	申请日	2008-11-14
[标]申请(专利权)人(译)	金斯道恩公司		
申请(专利权)人(译)	KINGSDOWN , INC		
当前申请(专利权)人(译)	KINGSDOWN INC.		
[标]发明人	OEXMAN ROBERT D SCOTT DAVID B		
发明人	OEXMAN, ROBERT D. SCOTT, DAVID B.		
IPC分类号	A61B5/00		
CPC分类号	A47C23/0433 A47C23/0435 A47C23/047 A47C27/082 A61B5/4815 A47C27/088 A47C27/10 A47C31/123 A61B5/6892 A47C27/083		
优先权	61/028591 2008-02-14 US		
其他公开文献	US20100318239A1		
外部链接	Espacenet USPTO		

摘要(译)

一种提供睡眠系统的可变支撑和可变舒适控制的装置和方法，该装置包括睡眠支撑构件，该睡眠支撑构件包括：舒适层，包括：多个舒适层可充气构件；舒适层传感器，被配置为提供与舒适层可充气构件的各个压力相关的数据；数据分析单元，被配置为分析由舒适层传感器提供的数据并生成分析的舒适层数据；控制单元，被配置为使用所分析的舒适层数据来控制每个相应的舒适层可充气构件内的压力。

