



(12) **United States Patent**
Knapp, II et al.

(10) **Patent No.:** **US 6,740,046 B2**
(45) **Date of Patent:** **May 25, 2004**

(54) **METHOD AND APPARATUS FOR ENHANCING PATIENT COMPLIANCE DURING INSPIRATION MEASUREMENTS**

(75) Inventors: **Keith N. Knapp, II**, Townsend, MA (US); **Alan M. Cohen**, Newton, MA (US)

(73) Assignee: **Boston Medical Technologies, Inc.**, Wakefield, MA (US)

(*) Notice: Subject to any disclaimer, the term of this patent is extended or adjusted under 35 U.S.C. 154(b) by 86 days.

(21) Appl. No.: **10/195,956**

(22) Filed: **Jul. 16, 2002**

(65) **Prior Publication Data**

US 2004/0015093 A1 Jan. 22, 2004

Related U.S. Application Data

(63) Continuation of application No. 09/507,770, filed on Feb. 18, 2000, which is a continuation of application No. 08/942,710, filed on Oct. 1, 1997, now Pat. No. 6,106,481.

(60) Provisional application No. 60/153,902, filed on Sep. 14, 1999.

(51) **Int. Cl.**⁷ **A61B 5/08**

(52) **U.S. Cl.** **600/538; 600/529**

(58) **Field of Search** **600/529, 532, 600/533, 534, 535, 537, 538, 539**

(56) **References Cited**

U.S. PATENT DOCUMENTS

2,649,573 A	8/1953	Goldberg et al.
3,142,796 A	7/1964	Goldberg et al.
3,340,867 A	9/1967	Kubicek et al.
3,407,818 A	10/1968	Costanzo
3,560,845 A	2/1971	Goldberg et al.
3,731,184 A	5/1973	Goldberg et al.
3,925,762 A	12/1975	Heitlinger et al.

3,991,304 A	11/1976	Hillsman
4,023,563 A	5/1977	Reynolds et al.
4,031,885 A	6/1977	Davis et al.
4,036,215 A	7/1977	Doll
4,137,910 A	2/1979	Murphy
4,216,779 A	8/1980	Squires et al.
4,240,442 A	12/1980	Andresen et al.
4,308,872 A	1/1982	Watson et al.
4,346,718 A	8/1982	Morris
4,364,397 A	12/1982	Citron et al.
4,367,753 A	1/1983	Jirak
4,408,614 A	10/1983	Weaver et al.
4,433,693 A	2/1984	Hochstein
4,440,177 A	4/1984	Anderson et al.
4,446,872 A	5/1984	Marsoner et al.
4,506,678 A	3/1985	Russell et al.
4,513,295 A	4/1985	Jones et al.
4,559,947 A	12/1985	Renger et al.

(List continued on next page.)

FOREIGN PATENT DOCUMENTS

EP	0 856 334	5/1998	
GB	2113101	3/1983 A61M/16/00
WO	WO 94 14374	7/1994	
WO	WO 97/12546	4/1997	
WO	WO 99 16506	8/1999	

Primary Examiner—Max F. Hindenburg
Assistant Examiner—Navin Natnithadhha
(74) *Attorney, Agent, or Firm*—Daly, Crowley & Mofford, LLP

(57) **ABSTRACT**

A system for enhancing patient compliance with a predetermined breathing pattern during inspiration measurements utilizes patient feedback based on inspiration flow. The measured inspiration flow is displayed on a first display and a target inspiration flow is displayed on a second display, preferably, disposed adjacent to the first display to facilitate visual comparison. The patient is instructed to breathe in a manner that causes the measured inspiration flow display to match, or follow the target inspiration flow display.

5 Claims, 14 Drawing Sheets

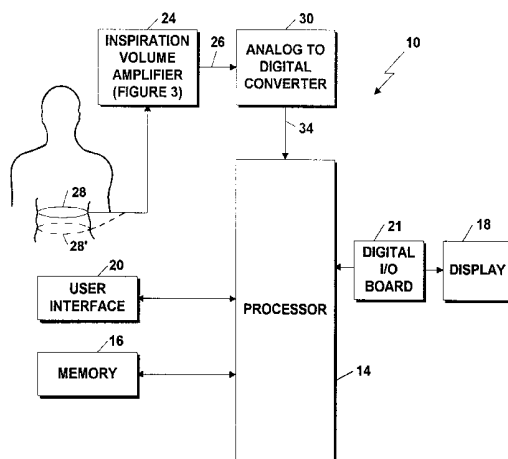

U.S. PATENT DOCUMENTS

4,649,929 A	3/1987	Weaver et al.	5,167,506 A	12/1992	Kilis et al.
4,679,144 A	7/1987	Cox et al.	5,269,301 A	12/1993	Cohen
4,692,148 A	9/1987	Kantrowitz et al.	5,277,189 A	1/1994	Jacobs
4,721,114 A	1/1988	DuFault et al.	5,285,793 A	2/1994	Slokvut et al.
4,777,960 A	10/1988	Berger et al.	5,299,119 A	3/1994	Kraf et al.
4,807,640 A	2/1989	Watson et al.	5,301,678 A	4/1994	Watson et al.
4,815,473 A	3/1989	Watson et al.	5,312,441 A	5/1994	Mader et al.
4,819,654 A	4/1989	Weaver et al.	5,316,008 A	5/1994	Suga et al.
4,832,038 A	5/1989	Arai et al.	5,330,508 A	7/1994	Gunderson
4,862,361 A	8/1989	Gordon et al.	5,333,106 A	7/1994	Lanpher et al.
4,869,262 A	9/1989	Orr et al.	5,360,008 A	11/1994	Campbell, Jr.
4,870,974 A	10/1989	Wang	5,390,679 A	2/1995	Martin
4,889,131 A	12/1989	Salem et al.	5,394,873 A	3/1995	Kraemer et al.
4,905,708 A	3/1990	Davies	5,400,795 A	3/1995	Murphy et al.
4,909,260 A	3/1990	Salem et al.	5,423,325 A	6/1995	Burton
4,913,146 A	4/1990	DeCote, Jr.	5,437,285 A	8/1995	Verrier et al.
4,930,517 A	6/1990	Cohen et al.	5,450,850 A	9/1995	Iinuma
4,934,377 A	6/1990	Bova et al.	5,483,969 A	1/1996	Testerman et al.
4,947,857 A	8/1990	Albert et al.	5,485,847 A	1/1996	Baker, Jr.
4,979,110 A	12/1990	Albrecht et al.	5,497,778 A	3/1996	Hon
4,984,158 A	1/1991	Hillsman	5,509,404 A	4/1996	Lloyd et al.
5,025,794 A	6/1991	Albert et al.	5,520,190 A	5/1996	Benedict et al.
5,027,824 A	7/1991	Dougherty et al.	5,543,012 A	8/1996	Watson et al.
5,148,812 A	9/1992	Verrier et al.	5,546,952 A	8/1996	Erickson
5,156,148 A	10/1992	Cohen	5,582,182 A	12/1996	Hillsman
5,159,935 A	11/1992	Sackner et al.	5,627,327 A	5/1997	Zanakis
			5,724,580 A	3/1998	Levin et al.

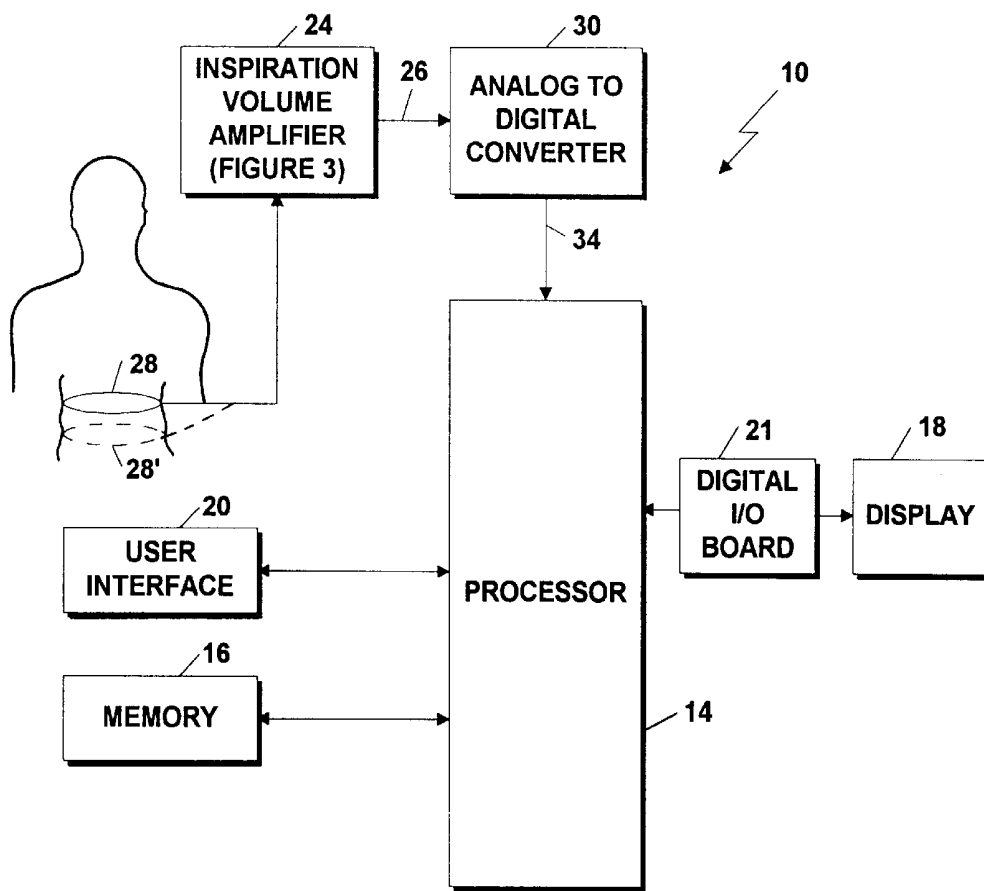

Figure 1

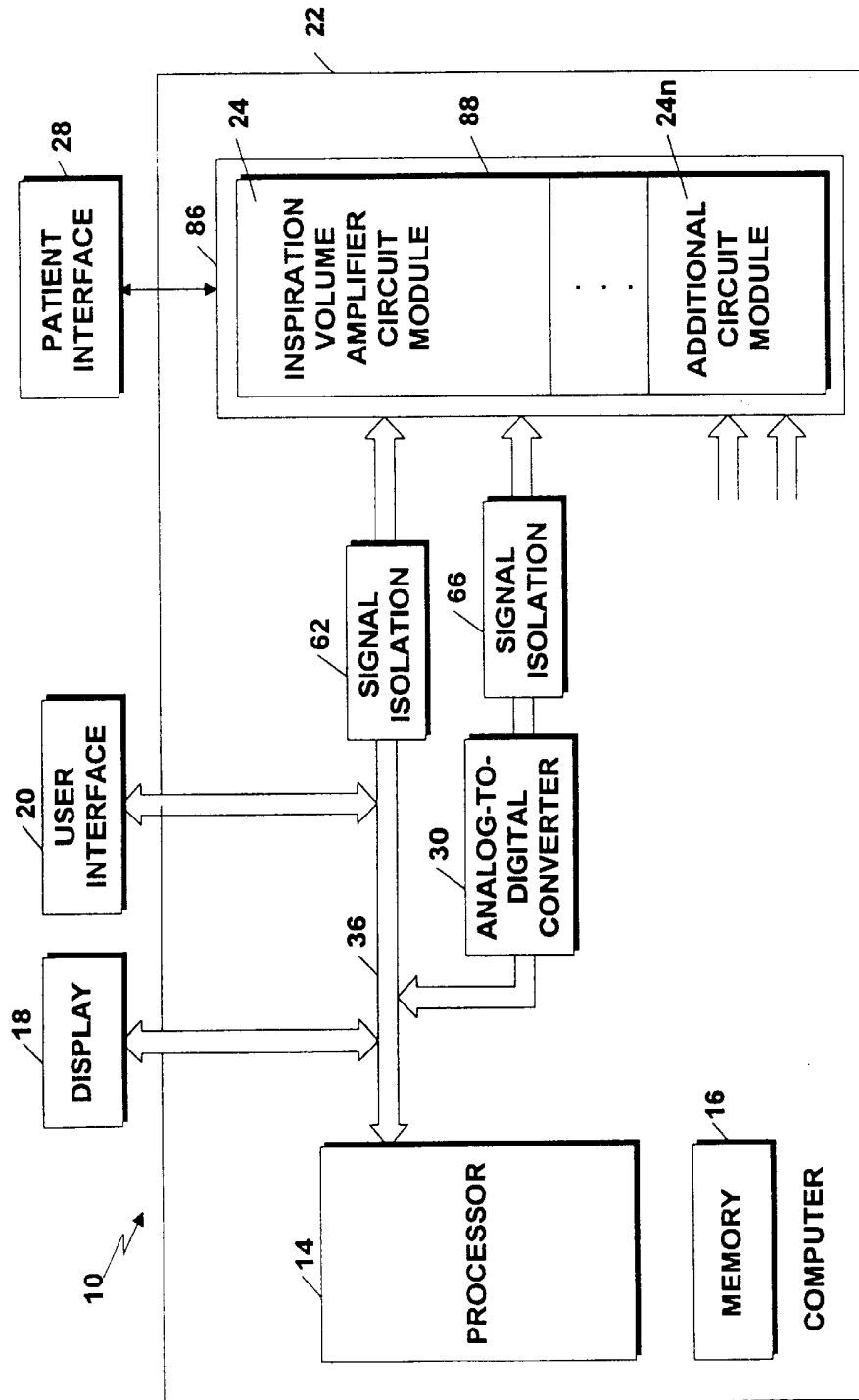

Figure 2

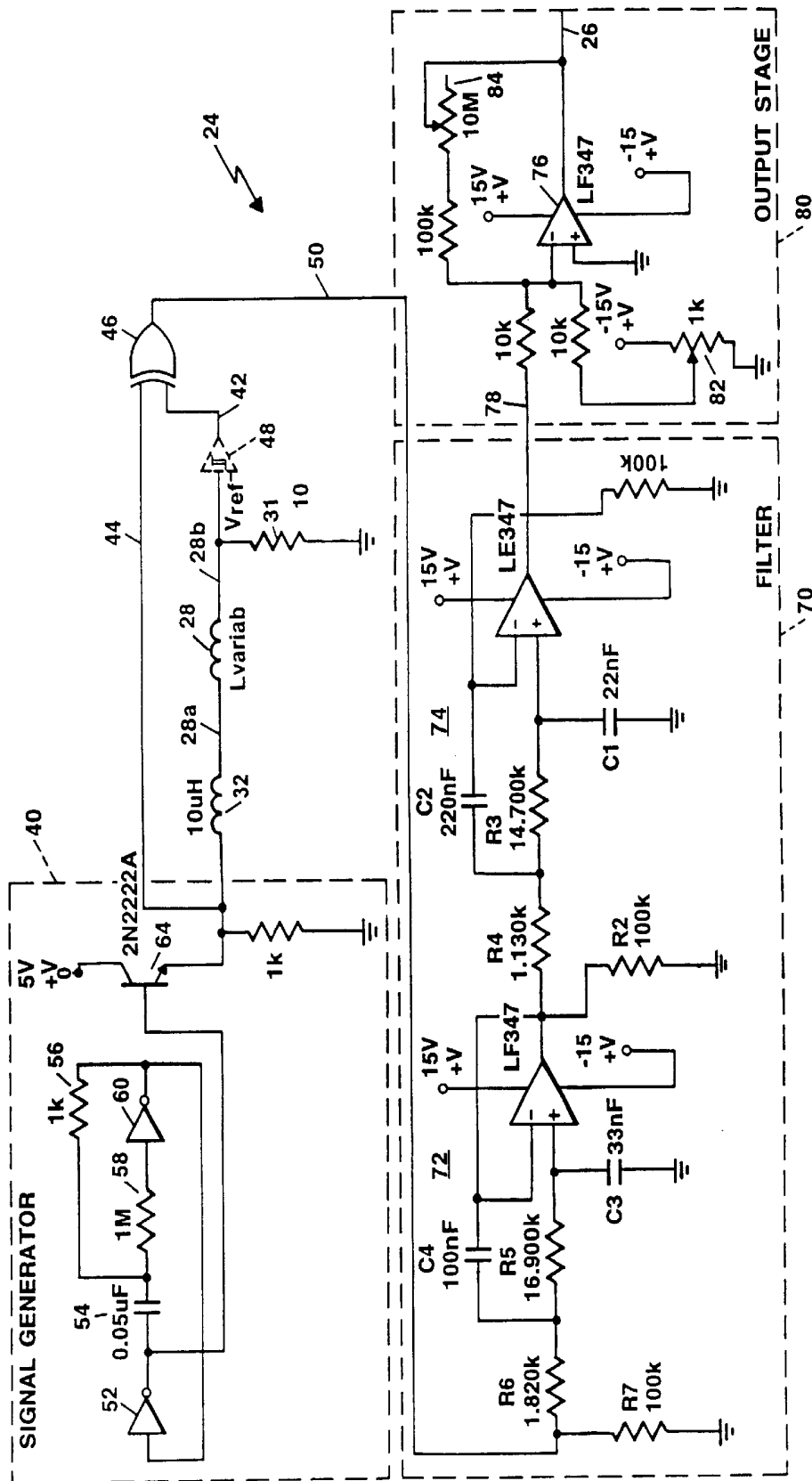

Figure 3

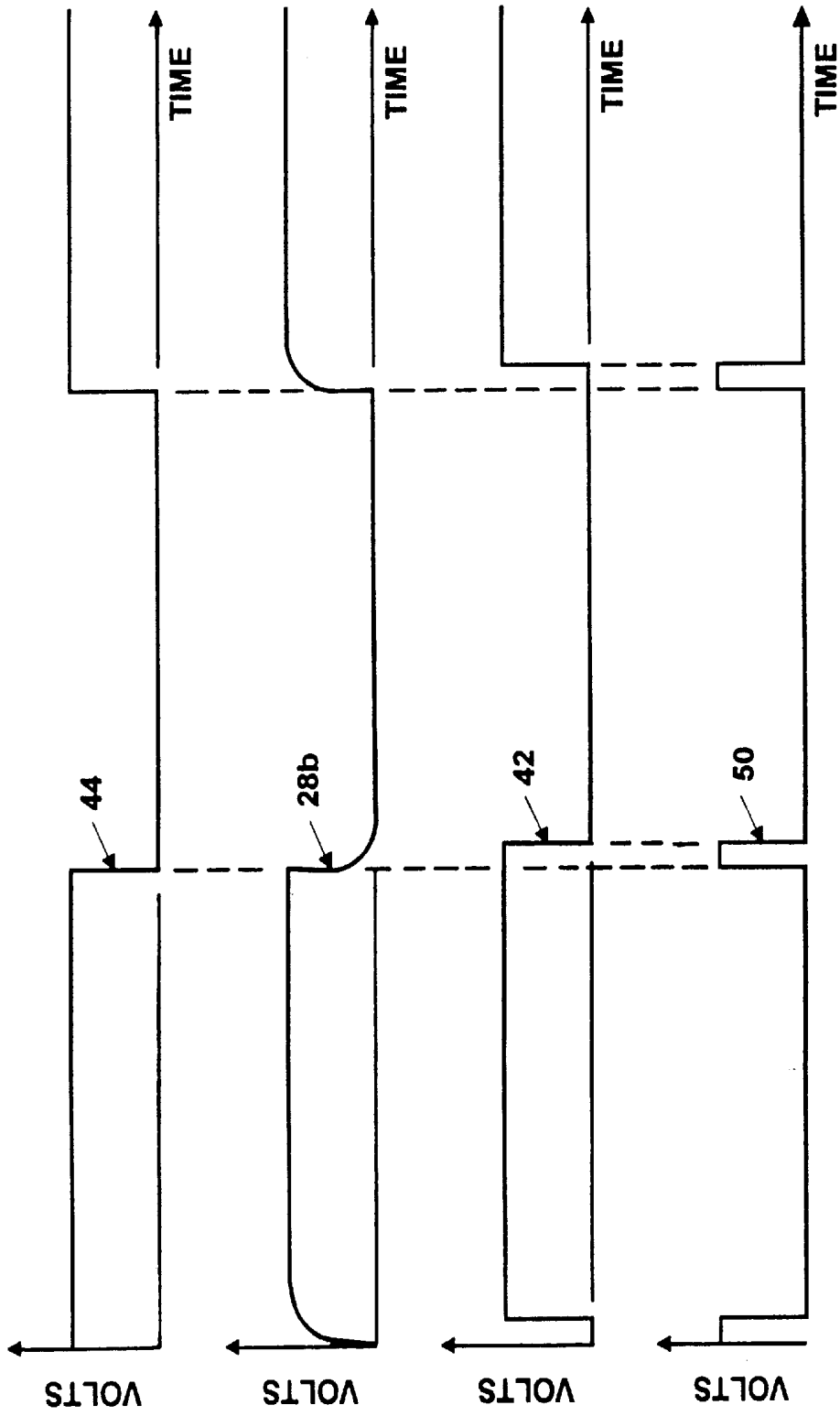

Figure 3A

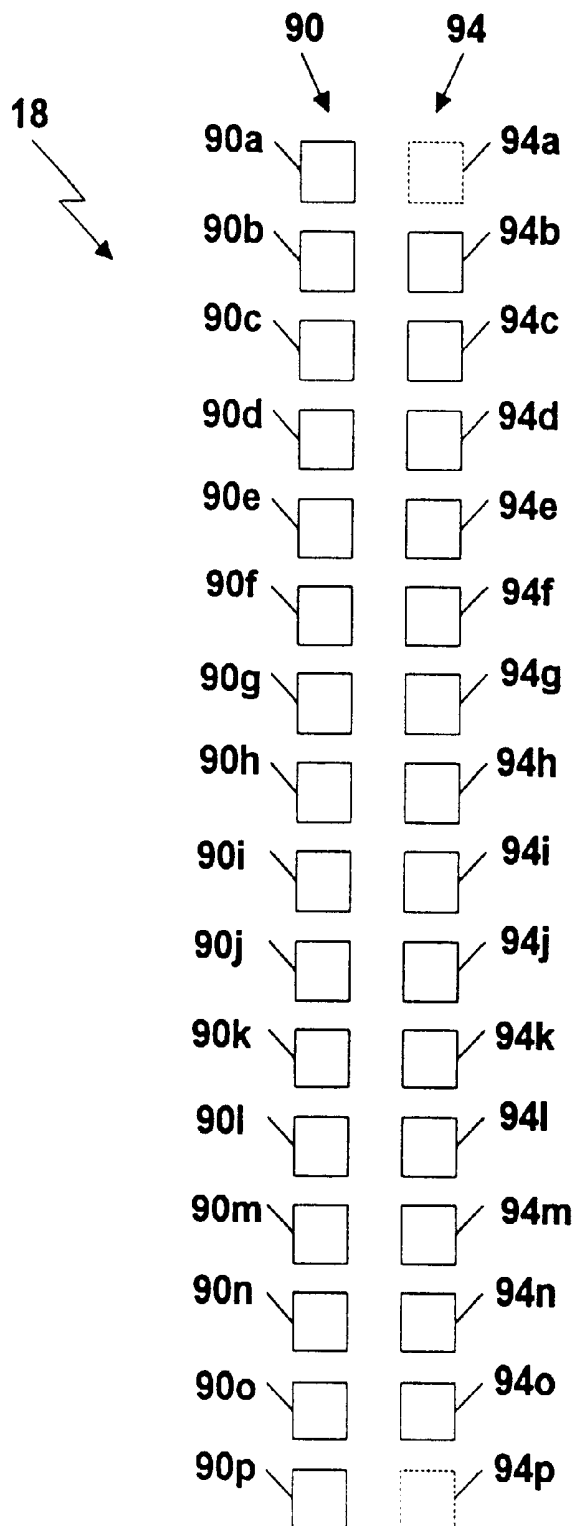

Figure 4

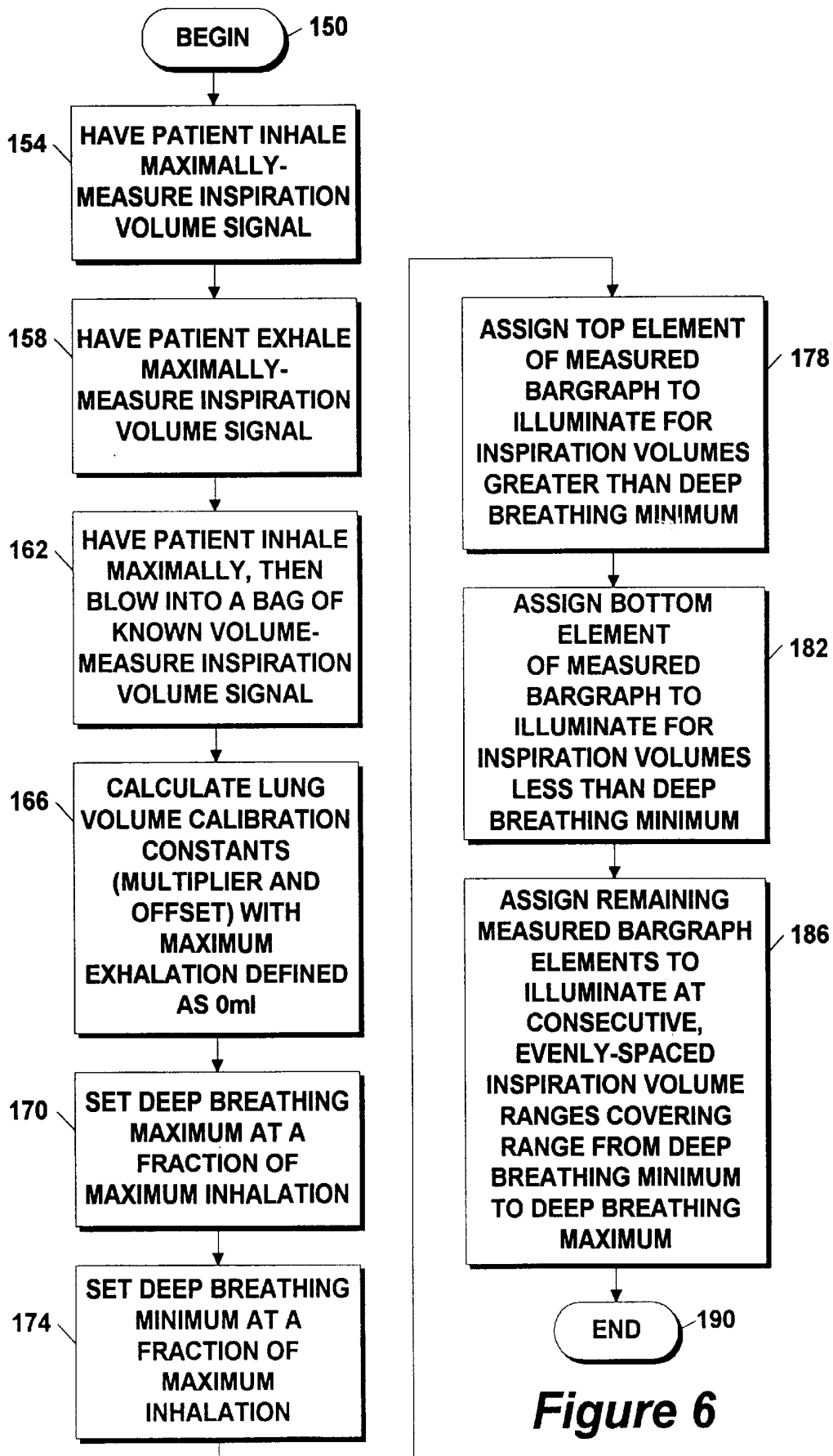

Figure 6

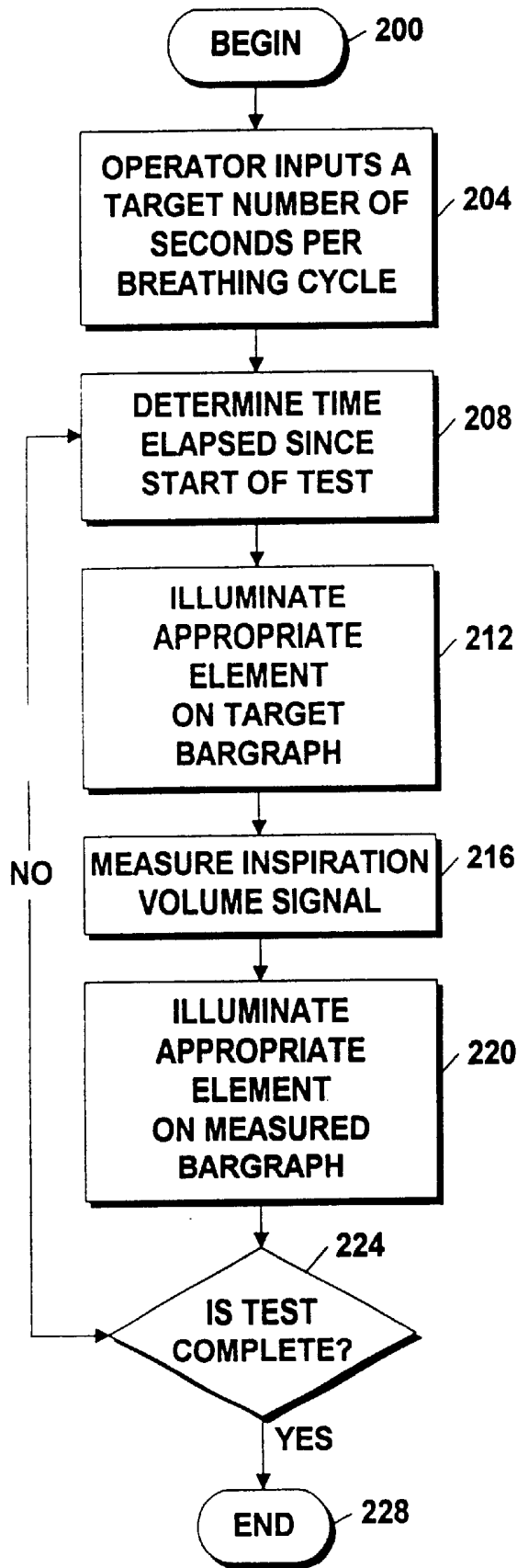

Figure 7

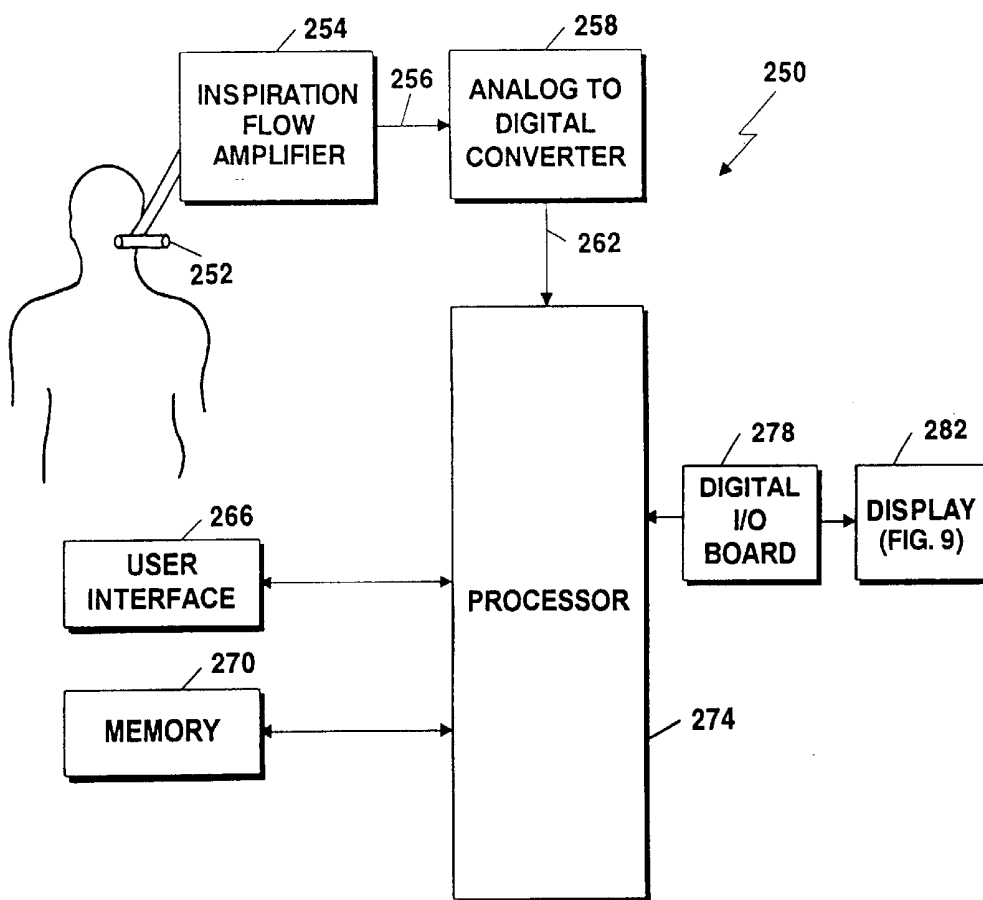

Figure 8

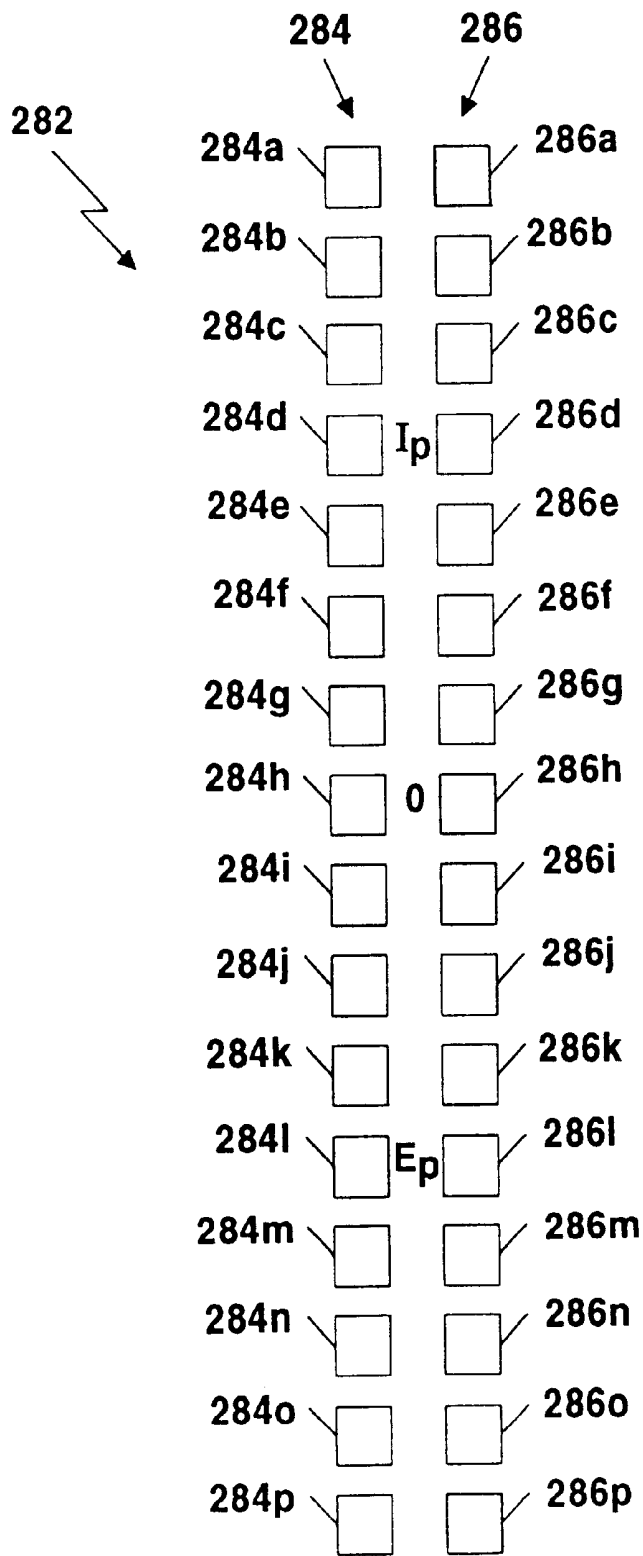

Figure 9

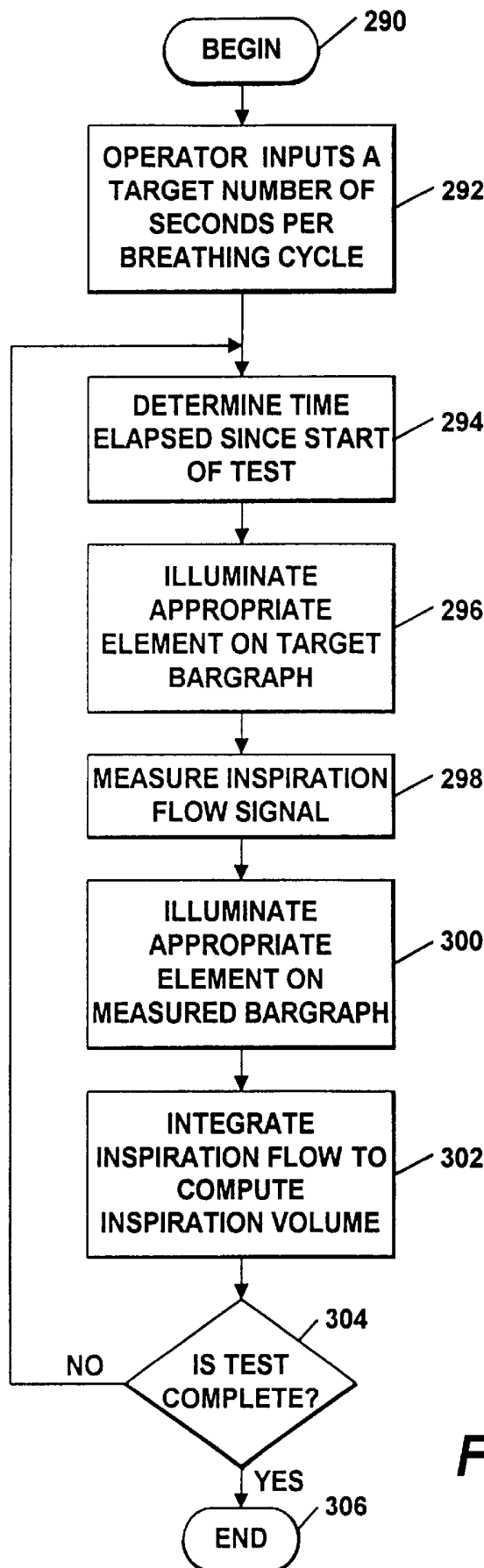

Figure 10

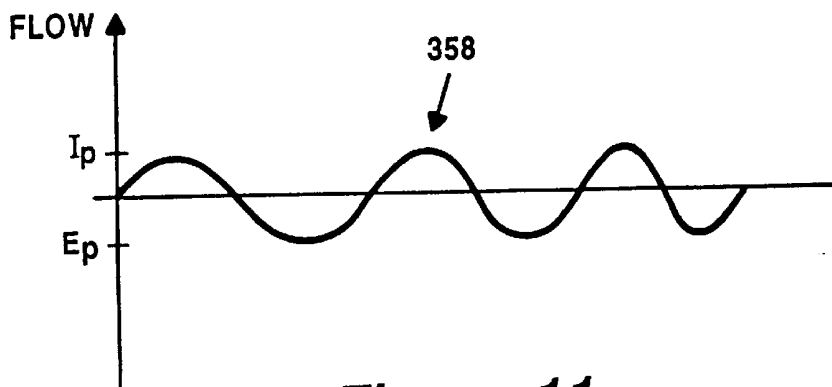
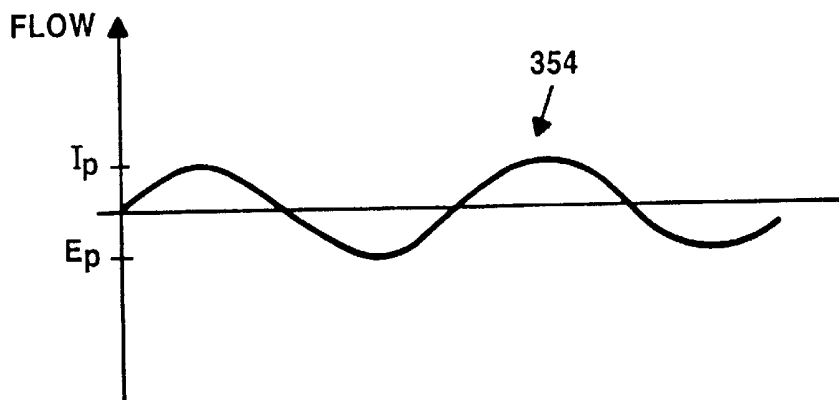
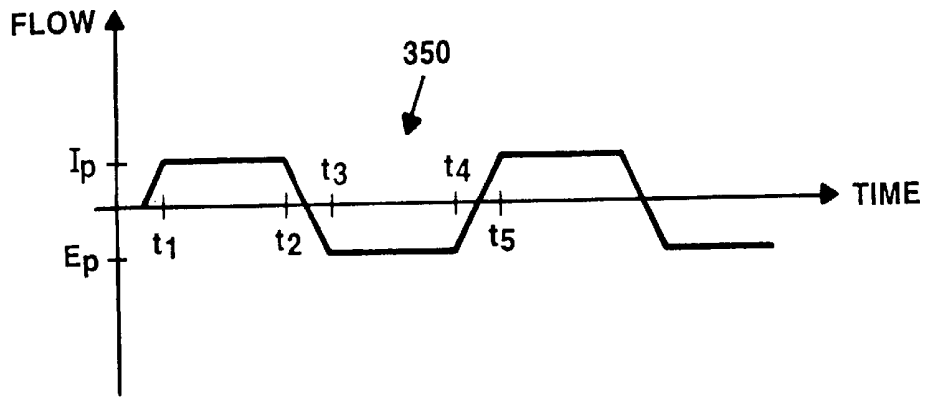

Figure 11

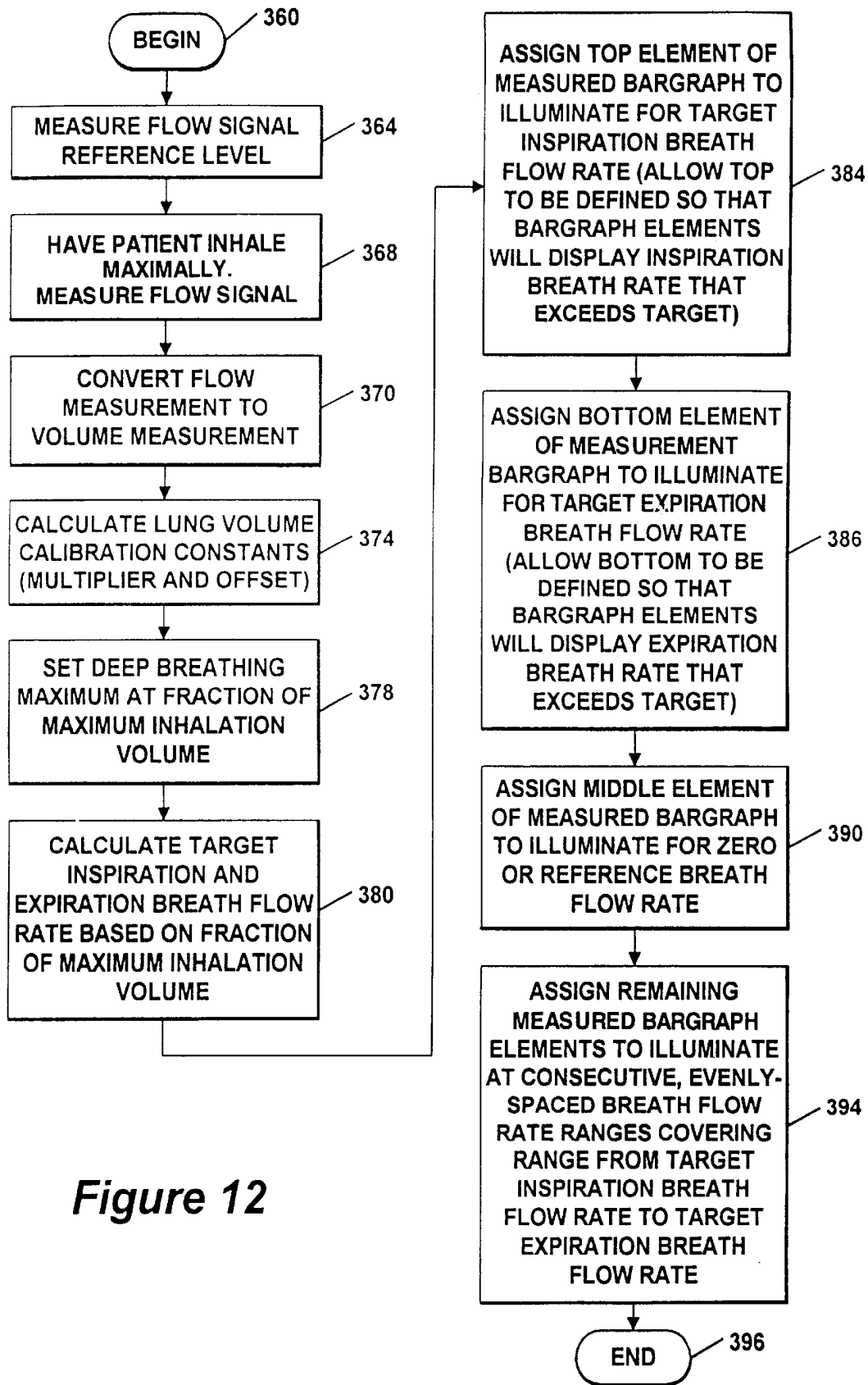

Figure 12

METHOD AND APPARATUS FOR ENHANCING PATIENT COMPLIANCE DURING INSPIRATION MEASUREMENTS

CROSS-REFERENCE TO RELATED APPLICATIONS

This application is a continuation of and claims the benefit under 35 U.S.C. § 120 to U.S. patent application Ser. No. 09/507,770, filed on Feb. 18, 2000, which in turn is a continuation-in-part of and claims priority under 35 U.S.C. § 120 to U.S. patent application Ser. No. 08/942,710, filed Oct. 1, 1997 which issued on Aug. 22, 2000 as U.S. Pat. No. 6,106,481 and also claims priority under 35 U.S.C. § 119(e) to U.S. Provisional Patent Application No. 60/153,902, filed on Sep. 14, 1999, all of which are incorporated herein by reference in their entirety.

STATEMENTS REGARDING FEDERALLY SPONSORED RESEARCH

Not applicable.

BACKGROUND OF THE INVENTION

Various medical diagnostic apparatus require that aspects of a patient's respiration, such as inspiration volume, be measured. Illustrative of such apparatus are heart rate variability assessment monitors which can be used in the diagnosis and treatment of various disease states.

In certain applications, it is advantageous to have the patient breathe in a particular manner when measuring inspiration volume. As one example, in neuropathy diagnosis, it is desirable that the patient breathe at a predetermined, constant frequency, such as on the order of six breaths/minute, or 0.10 Hz. However, even with specific instructions, it is difficult to ensure that the patient will breathe at the constant, predetermined frequency (i.e., to ensure "patient compliance" with a desired breathing pattern). Further, even if the patient complies closely with the desired breathing pattern, a patient's breathing often varies between tests, rendering the results of long-term testing less meaningful due to inter-test variability.

In an effort to enhance patient compliance and thus to reduce inter-test variability, some conventional systems include interactive mechanisms by which the patient is instructed to breathe in accordance with a particular pattern. For example, in a monitor sold under the product name HRView™ versions I and II by Boston Medical Technologies, Inc., different audio tones are used to indicate to the patient when to inhale and when to exhale. While this arrangement improves patient compliance and reduces inter-test variability, an even more effective way of ensuring patient compliance with a particular breathing pattern is desirable.

BRIEF SUMMARY OF THE INVENTION

Apparatus and methods for enhancing a patient's compliance with a predetermined breathing pattern include the use of feedback based on inspiration, or breath flow. Inspiration flow is the rate of breathing over time. A system according to the invention includes a device for measuring the inspiration flow of a patient, a first display on which the patient's measured inspiration flow is displayed and a second display on which a target inspiration flow is displayed. The system further includes a processor for controlling the first display in response to the measured inspiration flow and for controlling the second display in accordance with a

predetermined function. The patient is instructed to breathe so as to cause the measured inspiration flow display to match, or follow the target inspiration flow display.

With this arrangement, patient compliance with a predetermined breathing pattern is achieved in a highly accurate and repeatable manner. This is because modifying one's breathing to emulate an inspiration flow pattern has been found to be a relatively easy task, for example as compared to emulating an inspiration volume pattern. Further, inspiration flow feedback does not suffer from certain errors, such as may be associated with converting a measured flow signal into a volume signal. Thus, patient feedback based on inspiration flow results in a precise and repeatable matching of actual inspiration flow to a target inspiration flow.

Preferably, each of the first and second displays comprises a corresponding plurality of display elements disposed adjacent to one another in order to facilitate visual comparison. In one embodiment, the display elements are LEDs arranged in the form of a bar graph.

In one embodiment, the processor controls the second, target display portion according to a predetermined mathematical function. Illustrative mathematical functions include a sine wave function, a square wave function, a triangular function, a trapezoidal function, a chirp function or a combination of two or more such functions.

In accordance with a further aspect of the invention, the processor is responsive to the measured inspiration flow for computing the patient's inspiration volume. In a metronomic deep breathing test, the inspiration volume is used to compute a deep breathing maximum level which is used to prompt the patient to breath to a predetermined percentage of lung capacity. The inspiration volume is further processed to determine the extent to which the patient's breathing pattern matches the target breathing pattern.

Also described is a method for enhancing patient compliance with a predetermined breathing pattern including the steps of measuring the patient's inspiration flow, displaying the measured inspiration flow, displaying a target inspiration flow in accordance with a predetermined function, and instructing the patient to breathe in a manner which causes the measured inspiration flow display to match, or follow the target inspiration flow display.

According to a further aspect of the invention, a system for improving patient compliance with a predetermined breathing pattern includes a display for displaying the measured inspiration flow of the patient. The display includes a maximum flow display portion which indicates when the patient's inhalation flow exceeds a predetermined maximum level and a minimum flow display portion which indicates when the patient's exhalation flow falls below a predetermined minimum level. Both the predetermined maximum level for inhalation flow and the predetermined minimum level for exhalation flow are functions of the measured inspiration flow of the patient. The display further includes a target inspiration flow portion for displaying a target inspiration flow.

With this arrangement, a patient is provided with an indication that their inspiration flow (i.e., breathing rate) is either too high or too low. In this way, the patient is provided with further guidance in controlling his or her breathing so as to cause the measured inspiration flow to match the target inspiration flow, thereby further enhancing the accuracy and inter-test repeatability of the breathing test. This feature is particularly advantageous when conducting metronomic deep breathing testing for heart rate variability analysis in which the patient is instructed to breath to a predetermined percentage of his or her lung capacity at a predetermined frequency.

BRIEF DESCRIPTION OF THE DRAWINGS

The foregoing features of this invention, as well as the invention itself, may be more fully understood from the following description of the drawings in which:

FIG. 1 is a block diagram of a medical diagnostic system including apparatus for measuring inspiration volume and for enhancing patient compliance with a predetermined breathing pattern;

FIG. 2 is a block diagram of a computer-based implementation of the apparatus of FIG. 1;

FIG. 3 is a schematic of the inspiration volume amplifier and patient interface of FIG. 1;

FIG. 3A shows various signal waveforms associated with the circuit of FIG. 3;

FIG. 4 illustrates the display of FIG. 1;

FIGS. 4A, 4B, 4C, 4D and 4E illustrate exemplary states of the display of FIG. 4 in operation;

FIG. 5 is a schematic of the display of FIG. 4;

FIG. 6 is a flow diagram illustrating a method of calibrating the display of FIG. 4;

FIG. 7 is a flow diagram illustrating a method of operation of the system of FIG. 1;

FIG. 8 is a block diagram of a medical diagnostic system including apparatus for measuring inspiration flow and for enhancing patient compliance with a predetermined breathing pattern;

FIG. 9 illustrates the display of FIG. 8;

FIG. 10 is a flow diagram illustrating a method of operation of the medical diagnostic system of FIG. 8;

FIG. 11 shows several illustrative target inspiration flow waveforms; and

FIG. 12 is a flow diagram illustrating a method of calibrating the display of FIG. 8.

DETAILED DESCRIPTION OF THE INVENTION

Referring to FIG. 1, a medical diagnostic system 10 includes apparatus and implements techniques for measuring and displaying a patient's inspiration volume. The system 10 may be one of various types of medical diagnostic apparatus in which it is desired to measure a patient's inspiration volume. One illustrative system is a heart rate variability analysis system as described in connection with FIG. 9 below.

The system 10 further includes apparatus and implements techniques for improving patient compliance with performance of a desired task during measurements, such as breathing in a predetermined pattern during inspiration volume measurements. It will be appreciated by those of ordinary skill in the art that the apparatus and techniques described herein are suitable for enhancing patient compliance with performance of a desired task during various types of measurements. However, for simplicity of illustration, the system is described with particular reference to enhancing patient compliance with a predetermined breathing pattern during inspiration volume measurements.

The system 10 includes a processor 14 in electrical communication with a memory 16, a display 18 and a user interface 20. An inspiration volume amplifier circuit 24 is coupled to a patient interface 28 and includes circuitry for measuring the inductance of the patient interface to provide an analog amplifier output signal 26 indicative of the patient's instantaneous inspiration volume. The amplifier

output signal 26 is coupled to an analog-to-digital converter 30 for conversion into a digital signal 34 indicative of the patient's instantaneous inspiration volume which is coupled to the processor 14, as shown.

The patient interface 28 is provided in the form of a flexible conductor, or conductive loop, suitable for wrapping around and conforming to the patient's chest in an extensible manner (i.e., by expanding and contracting as the patient inhales and exhales, respectively). Various forms of the conductive loop 28 are suitable, such as a wire sewn into a flexible elastic belt which permits the wire to conform to the patient's body. Further suitable forms of the conductive loop 28 are shown and described in U.S. Pat. Nos. 4,815,473, 4,308,872, 4,807,640, 5,301,678 and 5,543,012, each of which is incorporated herein by reference. One suitable commercially available conductive loop is sold by Ambulatory Monitoring, Inc. of Ardsley, N.Y. under the product name RESPIBAND.

In certain cases, it may be desirable to utilize a plurality of loops (i.e., illustrated by loops 28 and 28') adapted for being disposed around and conforming to different regions of the patient's chest or torso. In such applications, the loops are coupled in series in the amplifier circuit 24 of FIG. 3. The sum of the inductance of such series-coupled loops provides an indication of the change in the patient's inspiration volume.

The processor 14 stores the digital inspiration volume signal 34 in memory 16 and displays the measured inspiration volume on the display 18. To this end, the processor 14 is coupled to the display 18 via a digital Input/Output (I/O) card 21 which latches digital output signals from the processor 14 for coupling to the display 18. One suitable digital I/O card is of the type sold by Computerboards of Mansfield, Mass. More particularly, the measured inspiration volume is displayed on a first portion of the display 18. A target inspiration volume is generated by the processor 14 and displayed on a second portion of the display 18 in response to a predetermined function, such as a sine wave function. Preferably, the measured and target inspiration volume display portions are arranged to facilitate their comparison. In use, the patient, or subject, is instructed to breathe in a manner which causes the measured inspiration volume display portion to match the target inspiration volume display portion.

The processor 14 may take various forms, such as the microprocessor of a standard personal computer, workstation or other microprocessor-driven device. As one example, the processor 14 is an INTEL-compatible microprocessor of an IBM-compatible personal computer running the MICROSOFT WINDOWS graphical user interface. The memory 16 includes a Random Access Memory (RAM) and the user interface may include a keyboard, touch screen and/or mouse. In the illustrative embodiment, the user interface 20 includes a touch screen incorporated into the display 18, the display is a flat panel LCD display of the type sold by Goldstar and the processor 14 and memory 16 are typical components associated with an IBM-compatible personal computer. The analog-to-digital converter 30 is a commercially available component; such as is sold by Computerboards of Mansfield, MA under the part number DA51402116. It will be appreciated by those of ordinary skill in the art, that the apparatus and techniques of the system 10 may be implemented on various equipment, both hardware and software.

Referring to FIG. 2, the inspiration volume amplifier 24 may be implemented in the form of a "circuit module"

adapted for insertion into an Input/Output (I/O) port or slot **86** of a standard personal computer chassis **22**. To this end, the circuit module **24** is housed in a metal or metallized-plastic box, or instrument chassis **88**, which is adapted for insertion into an opening of the computer chassis **22** typically used for a diskette drive, tape drive or CD-ROM drive.

The system **10** may include additional circuitry (not shown) for measuring various other physiological signals of the patient, such as a blood pressure signal or an electrocardiogram signal, in which case such circuitry is implemented in the form of one or more additional circuit modules. The instrument chassis **88** has an open front face which permits insertion of one or more circuit module(s) therein. The front of any unused portions of the instrument chassis is covered by metal or metallized, panels. Advantageously, the instrument chassis serves as a "Gauss cage" to reduce electromagnetic interference (EMI).

With this arrangement, the processor **14** can communicate with and control the inspiration volume amplifier circuit module **24** via the computer's standard busses and the circuit module can draw on the power available to the computer components. The processor **14** transmits any control information to the circuit module **24** via the computer's digital control bus **36** and receives the digital version **34** of the analog amplifier output signal **26** via the computer's digital control bus **36**. For safety reasons, it is preferable to isolate the computer bus **36** from the circuit module **24**, for example, with the use of opto-isolators **62**, **66**, respectively.

Referring to FIG. 3, the inspiration volume amplifier **24** is electrically connected to the conductive loop **28** (represented by the schematic symbol of an inductor). A signal generator **40** generates a square-wave signal **44** for coupling to first terminal **28a** of the loop **28** via an inductor **32**. A second terminal **28b** of the loop **28** is coupled to a resistor **31**, as shown.

Various circuitry is suitable for providing the signal generator **40**. In the illustrative embodiment, the signal generator **40** is an oscillator circuit, including inverters **52**, **60**, a capacitor **54** and resistors **56**, **58**. The output of inverter **52** is coupled to the base of an npn transistor **64** having an emitter at which the square-wave signal **44** is provided. The transistor **64** provides current gain to the square-wave signal.

The inductance of inductor **32** and loop **28** has the effect of rounding the edges of the square-wave signal **44** to provide a pseudo-square-wave signal at the second terminal **28b** of the inductor **28**. Preferably, a comparator **48** is coupled to the second terminal **28b** of the loop **28** as shown, in order to convert the pseudo-square-wave signal into a delayed square-wave signal **42**. In the illustrative embodiment, the comparator **48** is provided with significant hysteresis, such as on the order of four volts. Use of the comparator **48** with hysteresis has the advantage of increasing noise immunity and providing an accurate and reliable threshold level V_{ref} .

The amount of the delay between the square-wave signal **44** and the delayed square-wave signal **42** varies linearly with the variations in the inductance of loop **28**. Stated differently, the signal at the second terminal **28b** of the loop **28** is delayed as compared to the signal **44**, with the amount of the delay being indicative of the inductance of loop **28** and thus, of the patient's instantaneous inspiration volume.

The inductor **32** is provided in order to increase the LC time constant between square-wave signal **44** and the pseudo-square-wave signal at loop terminal **28b**. In the illustrative embodiment, inductor **32** is a $10\ \mu\text{H}$ inductor and

the conductive loop **28** has a nominal inductance of between approximately $3\ \mu\text{H}$ and $5\ \mu\text{H}$. In use, the inductance of the loop **28** varies on the order of between $0.02\ \mu\text{H}$ and $0.004\ \mu\text{H}$, depending on factors such as the size of the patient and the deepness of breathing. If the LC time constant is too small, then the delay between the square-wave signal **44** and the delayed square-wave signal **42** may be too small to measure accurately. Stated differently, the LC time constant needs to be at least as long as the time needed for the output of the comparator **48** and the exclusive-OR gate **46** to respond.

It will be appreciated by those of ordinary skill in the art that the delay between the square-wave signal **44** and the delayed square-wave signal **42** at the output of the comparator **48** can be measured using various circuitry and techniques. In the illustrative embodiment, an exclusive-OR gate **46** is provided for this purpose. A first input of the exclusive-OR gate **46** is responsive to the square-wave signal **44** and a second input is responsive to the delayed square-wave signal **42** at the output of the comparator **48**.

Assuming that input signals **44** and **42** to the exclusive-OR gate **46** are initially at logic low levels, the output signal **50** of the exclusive-OR gate **46** transitions to a logic high level when the square-wave signal **44** goes high and transitions to a logic low level when the delayed square-wave signal **42** goes high. From the initial condition where both input signals **42**, **44** to the exclusive-OR gate **46** are high, the output of the gate **46** goes high when the square-wave signal **44** goes low and goes low when the delayed square-wave signal **42** goes low. The output signal **50** thus has a duty cycle (i.e., ratio of the interval during which the signal is high to the total period) proportional to the delay between the signals **42** and **44** and thus, to the patient's inspiration volume.

Referring also to FIG. 3A, the above-described operation of the exclusive-OR gate **46**, as well as the relationship between various signals of circuit of FIG. 3 are illustrated. In particular, the signal waveforms shown in FIG. 3A include the square-wave signal **44**, the pseudo-square-wave signal at terminal **28b**, the output signal **42** of comparator **48** and the output signal **50** of the exclusive-OR gate **46**, all drawn to the same time scale.

The output signal **50** of the exclusive-OR gate **46** is further processed by a filter **70** and an output stage. The filter **70** is a low pass filter which smoothes the output signal **50** in order to facilitate measurement of the delay between the square-wave signal **44** and the delayed square-wave signal **42**. In particular, the low pass filter **70** provides a low-frequency signal **78** having an amplitude proportional to the duty cycle of the signal **50**. In the illustrative embodiment, filter **70** is a fourth-order low pass filter comprising two stages **72** and **74** and having a nominal cutoff frequency of approximately 350 Hz. In general, the cutoff frequency should be selected to be high enough so that the filter output signal **78** adequately responds to changes in the inductance of loop **28** and low enough to substantially reduce ripple at the frequency of the signal generator **40**.

The filter output signal **78** is coupled to an operational amplifier **76** of the output stage **80**. The output stage **80** includes an offset adjustment control **82** in the form of a potentiometer coupled to the inverting input of the amplifier **76**. The potentiometer **82** is user-adjustable in order to reduce or remove the DC offset of the signal **78**. This can be achieved by displaying the filtered signal **78** on the display **18**, thereby enabling the user to adjust the potentiometer **82** until the DC offset is reduced or removed. Alternatively, an automated method for removing the DC offset may be implemented.

The output stage **80** further includes a gain adjustment control **84** in the form of a potentiometer coupled in feedback relationship with the operational amplifier **76**, as shown. Since the amplitude of the digital output signal **50** is attenuated by the filter **70**, it is generally desirable to increase the gain by adjusting the potentiometer **84**. Preferably, the gain is selected so that the voltage difference in the amplifier output signal **26** between full exhalation and full inhalation by the patient is on the order of two volts centered within the supply voltage range (e.g., zero to five volts). In the illustrative embodiment, the potentiometer **84** is adjustable to vary the gain by a factor of between 10 and 1000. The output signal **26** of the amplifier is an analog signal having an amplitude that varies linearly with changes in the patient's inspiration volume.

Referring to FIG. 4, the display **18** includes two portions **90** and **94**. The first display portion **90** is used to display the patient's actual measured inspiration volume and the second display portion **94** is used to display a target, or desired inspiration volume to which the patient's breathing preferably conforms. In general, the target display portion **94** displays a predetermined breathing pattern including both an amplitude of inhalation and exhalation and a rate, or frequency. Preferably, the breathing pattern displayed on the target inspiration volume display follows a predetermined mathematical function, such as a sine wave function or a chirp function in which the frequency increases as a function of time. However, alternatively, the predetermined pattern may be a random pattern.

Each display portion **90**, **94** includes a plurality of display elements **90a-90p**, **94a-94p**, respectively, and in the illustrative embodiment, includes sixteen light emitting diodes (LEDs). The LEDs of the display portions **90**, **94** are arranged vertically in the form of bar graphs, as shown. Preferably, the display portions **90**, **94** are disposed adjacent to one another in order to facilitate rapid visual comparison of the display elements, as will be described. It will be appreciated by those of ordinary skill in the art however, that various types of display elements and arrangements are possible and suitable in order to achieve the benefits described herein.

The bar graph display portions **90** and **94** are arranged such that illumination of each LED indicates a particular level, or range of lung volume. In the illustrative embodiment, the lowest LED corresponds to a greatest level of exhalation and the highest LED corresponds to a greatest level of inhalation. More particularly, with respect to the measured inspiration volume display portion **90**, the lowest LED **90p** indicates that the measured inspiration volume is less than a predetermined minimum level and the highest LED **90a** indicates that the measured inspiration volume is greater than a predetermined maximum level.

The target display portion **94** is shown to include the same number of LEDs as the measured display portion **90**, with each of the target LEDs **94a-94p** disposed adjacent to, and preferably in substantial horizontal alignment with, a corresponding one of the LEDs **90a-90p** of the measured inspiration volume display portion **90**. However, since the uppermost measured inspiration volume LED **90a** and the lowermost measured inspiration volume LED **90p** indicate that the patient's inspiration volume is either greater than or less than predetermined maximum and minimum levels, respectively, the corresponding LEDs **94a**, **94p** of the target display portion **94** are not utilized since these are not desired conditions. However, LEDs **94a** and **94p** may be included since the bar graph display portions **90**, **94** may be used display other information.

In operation, one of the LEDs in each of the display portions **90** and **94** is illuminated by the processor **14** at any given time. The illuminated one of the LEDs **94b-94o** of the target display portion **94** indicates the desired level of inhalation or exhalation at the particular time; whereas, the illuminated one of the LEDs **90a-90p** of the measured inspiration volume display portion **90** indicates the patient's present inspiration volume. The patient is instructed to breathe in a manner which causes the measured inspiration volume display portion **90** to illuminate the one of the LEDs **94b-94o** which corresponds to, and preferably is horizontally aligned with, the illuminated one of the target LEDs **94a-94o**. Stated differently, the patient is instructed to breathe so as to cause the measured display portion **90** to match, or follow the target display portion **94**.

FIGS. 4A-4E illustrate examples of various states of the display portions **90** and **94** during operation. The progression of FIGS. 4A-4E illustrates a target inspiration volume pattern in the form of a sine wave function shown on target display portion **94**. In FIG. 4A, the target inspiration volume is indicated by illuminated LED **94o** and the patient's actual inspiration volume matches the target volume since the horizontally aligned LED **90o** is illuminated. In each of FIGS. 4B-4D, the discrepancy between the illuminated measured inspiration volume LED and the illuminated target inspiration volume LED indicates that the patient should increase his or her inspiration volume to comply with the target breathing pattern. In FIG. 4E, the patient's inspiration volume has caught up to, and matches the target inspiration volume since the measured inspiration volume LED **90k** is illuminated when the horizontally aligned target inspiration volume LED **94k** is illuminated.

Referring to FIG. 5, each display portion **90**, **94** includes a respective demultiplexer **96**, **98** which is responsive to four data input signals **102a**, **102b**, **102c** and **102d** for providing digital output signals on signal lines **96a-96p**, **98b-98o** in order to illuminate an appropriate one of the LEDs **90a-90p**, **94a-94o**, respectively. In the illustrative embodiment, the demultiplexers **96**, **98** are of the type sold by National Semiconductor of Santa Clara, Calif. under the product number 74HC4514. The processor **14** provides the four data input signals **102a-102d** to each of the demultiplexers **96**, **98** via the digital I/O board **21** (FIG. 1) which is coupled to a connector **104**.

Each LED **90a-90p**, **94a-94p** is coupled between an output signal line of the respective demultiplexer **96**, **98** and through a current limiting resistor to ground. More particularly, LEDs **90a-90p** are coupled between output signal lines **96a-96p** of demultiplexer **96** and LEDs **94a-94p** are coupled between output signal lines **98a-98p** of demultiplexer **98**, respectively. Thus, when the demultiplexer output signal, on the respective signal line goes high, the corresponding LED is illuminated.

Also provided by the processor **14** to each of the demultiplexers **96**, **98** via the digital I/O board **21** and connector **104** is a strobe signal **110**, **112** and an inhibit signal **114**, **116**, respectively. The strobe signals **110**, **112** control latching of the data input signals **102a-102d** by the respective demultiplexer **96**, **98**. More particularly, a positive-going pulse on a strobe signal line causes the respective demultiplexer to

capture, or latch in the data input signals and to provide output signals according to the following Table:

Signal Line 102a	Signal Line 102b	Signal Line 102c	Signal Line 102d	Illuminated LED when strobe 110 high	Illuminated LED when strobe 112 high
0	0	0	0	90p	
0	0	0	1	90o	94o
0	0	1	0	90n	94n
0	0	1	1	90m	94m
0	1	0	0	90l	94l
0	1	0	1	90k	94k
0	1	1	0	90j	94j
0	1	1	1	90i	94i
1	0	0	0	90h	94h
1	0	0	1	90g	94g
1	0	1	0	90f	94f
1	0	1	1	90e	94e
1	1	0	0	90d	94d
1	1	0	1	90c	94c
1	1	1	0	90b	94b
1	1	1	1	90a	

The inhibit signals **114,116** are active-high signals for the demultiplexers **96, 98**. When an inhibit signal **114,116** is at disabling a logic the outputs of high level, all of the outputs of the demultiplexer are low, thereby turning off all of the **25** respective LEDs. During certain stages of operation, it may be desirable to turn off one or both of the display portions **90**, when other features of the system **10** and display **18** are in use.

Referring to FIG. 6, a method of calibrating the display portions **90** and **94** commences in step **150**, following which the patient, or subject is instructed to inhale as deeply as possible, to a maximal inhalation level in step **154**. Also in step **154**, the maximal inhalation level is measured by the inspiration volume amplifier **24** (FIG. 1) and the value of the output signal **34** is stored by the processor **14** in the memory **16**. In subsequent step **158**, the patient is instructed to exhale as deeply as possible, to a maximal exhalation level which is measured and stored in memory **16**.

In step **162**, the patient is instructed to inhale as deeply as possible and then to exhale into a bag of known volume, such as 800 mL, following which the inspiration volume amplifier **24** measures the patient's inspiration volume. This inspiration volume measurement thus provides a data point at which the measured inspiration volume is known to have a value equal to the maximal inhalation level minus the volume of the bag.

In step **166**, the processor **14** calculates lung volume calibration constants for the patient, which include multiplier and offset constants used to convert the digital version **34** of the amplifier output signal **26** into a physical measure of the patient's inspiration volume, such as milliliters.

The calibration multiplier is determined in response to steps **154** and **162**. The difference between the value of the digital version **34** of the amplifier signal **26** in steps **154** and **162** corresponds to the known volume of the bag. Thus, the number of milliliters represented by each voltage gradation is computed by setting the voltage difference between the inspiration volume signal measured in step **162** and the inspiration volume signal measured in step **154** equal to the volume of the bag, such as 800 mL.

In the illustrative embodiment, the maximum exhalation level is defined as zero milliliters. The offset constant is selected so that when it is added to the product of the voltage

measured in step **158** and the calibration multiplier, it results in zero milliliters.

Having determined the subject's maximum inhalation volume and maximum exhalation volume, in process step **170**, a predetermined fraction of the maximum inhalation volume is computed to define a deep breathing maximum. In the illustrative embodiment, the deep breathing maximum is approximately 85% of the patient's maximum inhalation volume. Similarly, in step **174**, a predetermined fraction of the patient's maximum inhalation volume is computed and defines a deep breathing minimum. In the illustrative embodiment, the deep breathing minimum is 15% of the patient's maximum inhalation volume.

In step **178**, the top LED **90a** of the measured inspiration volume display portion **90** is assigned to illuminate whenever the measured inspiration volume exceeds the deep breathing maximum. Similarly, in step **182**, the bottom LED **90p** is assigned to illuminate whenever the measured inspiration volume is less than the deep breathing minimum.

Thereafter, in step **186**, the range of inspiration volume represented by each of the remaining display elements **90b-90o** and **94b-94o** of the display portions **90, 94**, respectively, is determined. To this end, the total volume between the deep breathing maximum and the deep breathing minimum is divided by the number display devices, following which the calibration process terminates in step **190**. For example, consider the case where the patient's deep breathing minimum is 150 mL and the deep breathing maximum is 850 mL. In this case, each of LEDs **90b-90o** and **94b-94o** represents approximately 50 mL of inspiration volume.

Referring to FIG. 7, a method of operation of the processor **14** in driving the display portions **90** and **94** commences in step **200**, following which the operator or user of the system enters a target breathing rate (i.e., a desired number of seconds per breathing cycle). As noted above, a typical target rate useful in neuropathy diagnosis is on the order of ten seconds per breathing cycle.

In step **208**, the processor **14** determines how many seconds have lapsed since the beginning of the particular test. Thereafter, in step **212**, the appropriate LED **94b-94o** on the target display portion **94** is illuminated. In the illustrative embodiment, the target display portion **94** is controlled in accordance with a sine wave function and, specifically, according to the following equation:

$$(N - 2 - 0.5)\sin\left(\frac{2\pi \cdot \text{target breathing rate}}{\text{elapsed time}}\right) + (N - 2 + 0.5)$$

where N is the number of utilized LEDs **94b-94o** of the target display portion. The integer portion of the result of the above equation indicates the number of the LED that is activated (i.e., where {LED **94o** is LED one, LED **94n** is LED two, etc.). The processor **14** activates the appropriate LED by providing the data input signals **102a-102d** at the appropriate logic levels according to the Table above and the lung volume range assigned to each LED **94b-94o** in calibration steps **186** (FIG. 6) and by providing a positive-going pulse on the strobe signal line **112** to the demultiplexer **98** (FIG. 5).

Once the appropriate LED on the target inspiration volume display portion **94** is illuminated, the actual inspiration volume is measured by sampling the amplifier output signal **34** (FIG. 1) in step **216**. Thereafter, in step **220**, the processor **14** activates the appropriate LED on the measured display portion **90** in accordance with the value of the digital signal

34, the lung volume range assigned to each LED 90a-90p in calibration steps 178, 182 and 186 (FIG. 6) and the Table provided above.

In subsequent step 224, it is determined whether the test is complete. Typically, the patient's inspiration volume is measured over a predetermined interval measured by a timer associated with the processor 14. If the test is not yet complete, then the process is repeated starting at step 208. Alternatively, the process is terminated in step 228. Use of lung volume as a feedback parameter in order to get a patient to breathe in a predetermined manner provides an improvement over the conventional use of audio tones to prompt a patient's breathing. However, in systems in which the inspiration volume is measured by measuring inspiration flow and converting the flow signal into a volume signal, inaccuracies occur. In particular, in computing the integral of the measured flow signal, an error would occur in the resulting volume signal whereby the volume signal would not return to its starting point at the end of any given breath cycle and this error is compounded over multiple breath cycles.

Certain physiological tests require that a patient breathe to a percentage of his or her maximum lung capacity at a predetermined frequency and for a predetermined duration. One such test is the metronomic deep breathing test used in heart rate variability analysis. While providing a patient with feedback as to measured lung volume as described above in connection with FIGS. 1-7 is one way of achieving a desired inspiration volume, it has been found that the use of inspiration flow for this purpose has advantages. In particular, a target inspiration flow pattern is easier for a patient to emulate than a target lung volume pattern. As a result, the extent to which the measured inspiration flow matches the target inspiration flow is increased and the repeatability of the inspiration tests is enhanced. Further, when inspiration flow is measured and then integrated to provide the feedback inspiration volume signal, an error can accumulate over time by which the inspiration volume signal does not return to its starting amplitude at the end of each breathing cycle. Use of measured inspiration flow for providing patient feedback does not suffer from this problem.

Referring to FIG. 8, a system 250 for enhancing patient compliance with a predetermined breathing pattern utilizes patient feedback based on inspiration flow. The system 250 includes a patient interface 252 for measuring the patient's inspiration flow. Various devices 252 are suitable for this purpose. One suitable is available from Fukuda Sangyo Co. Ltd. of Japan and includes a mouthpiece having two chambers divided by a restriction. Both of the chambers are coupled through tubes to a pressure transducer in the amplifier 254 for measurement of the differential pressure between the chambers. It will be appreciated by those of ordinary skill in the art that various conventional flow measuring devices may be used to provide the patient interface 252.

The remaining components of the system 250 are substantially identical to like components of the system 10 described above in conjunction with FIG. 1, except for the differences as noted below. The inspiration flow amplifier 254 amplifies the pressure transducer output signal to provide an amplified signal 256 to an analog-to-digital converter 258. The analog-to-digital converter 258 converts the amplified output signal 256 into a digital signal 262 indicative of the patient's instantaneous inspiration flow for coupling to a processor 274.

The processor 274 displays the measured inspiration flow on a display 282. To this end, the processor 274 is coupled to the display 282 through a digital input/output (I/O) card

278 which latches digital output signals from the processor 274 for coupling to the display 282.

The processor 274 further controls the display 282 to display a target inspiration flow. The processor 274 is otherwise substantially identical to the processor 14 of FIG. 1 and thus may take the various forms and be provided by the same commercially available components as described above in connection with processor 14. Further, the memory 270 and the user interface 266 are substantially identical to memory 16 and user interface 20 of FIG. 1 and thus may take the various forms described above. The components comprising the system 250 may be arranged in the form of circuit modules adapted for insertion into a standard personal computer chassis as described above in connection of FIG. 2.

Referring also to FIG. 9, the display 282 includes a first display portion 284 for displaying the measured inspiration flow signal and a second display portion 286 for displaying a target inspiration flow signal. Each display portion 284, 286 includes a plurality of display elements 284a-284p, 286a-286p, respectively. In the illustrative embodiment, each such display portion includes sixteen LEDs, but the number of LEDs can be readily varied. In some applications, it may be desirable to use more LEDs, such as on the order of between 16 and 64 LEDs, in order to enhance the resolution of the display.

The LEDs of each display portion 284, 286 are arranged vertically in the form of a bar graph, as shown. Preferably, the display portions 284, 286 are disposed adjacent to one another in order to facilitate rapid visual comparison of the display elements. It will be appreciated by those of ordinary skill in the art, however, that various types of display elements and arrangements are possible in order to achieve the benefits of the present invention. For example, in some applications it may be desirable to use an odd number of display elements in order to provide a centered LED as a "zero" reference point.

The display portions 284, 286 are arranged such that illumination of each LED indicates a particular level, or range of inspiration flow (i.e., rate of breathing). The uppermost LED corresponds to the greatest rate of inhalation and the lowermost LED corresponds to the greatest rate of exhalation.

According to a further aspect of the invention, the measured display portion 284 includes a maximum inhalation flow display portion including LEDs 284a-284c and a minimum exhalation flow display portion including LEDs 284m-284p. The maximum inhalation flow indicator LED 284c is illuminated when the patient's inhalation flow exceeds a predetermined maximum level I_p by a first predetermined amount, the maximum inhalation flow indicator LED 284b is illuminated when the patient's inhalation flow exceeds the predetermined maximum level I_p by a second, greater predetermined amount, and the maximum inhalation flow indicator LED 284a is illuminated when the patient's inhalation flow exceeds the predetermined maximum level I_p by a third, greatest predetermined amount. Similarly, the minimum exhalation flow indicator LEDs 284m-284p are illuminated when the patient's exhalation flow falls below a predetermined minimum level E_p by a corresponding predetermined amount, with LED 284p indicating the greatest deviation between the patient's inspiration flow and the predetermined minimum level E_p .

With this arrangement, the efficacy of the system 250 in having a patient's breathing conform to the target breathing pattern is enhanced. This is because the patient is provided with the additional information that his or her breathing rate

is either greater than or less than predetermined maximum and minimum levels and to what extent, respectively. The target inspiration flow display portion **286** may include the same number of LEDs as the measured inspiration flow display portion **284** or, alternatively, may omit the uppermost and lowermost LEDs **286a–286c** and **286m–286p** in horizontal alignment with measured inspiration flow LEDs **284a–284c** and **284m–284p**. This is because the uppermost and lowermost measured inspiration flow elements **284a–284c** and **284m–284p** are used to indicate that the patient's inspiration flow is either greater than or less than is ever desired. Thus, even when target LEDs **286a–286c** and **286m–286p** are present, they are not used.

In operation, one of the LEDs in each of the display portions **284**, **286** is illuminated by the processor **274** at any given time. The illuminated one of the LEDs **286d–286l** of the target display portion **286** indicates the desired level or range of inspiration flow between a target inhalation rate I_p and a target exhalation rate E_p , with the LED **286h** representing a zero reference point, or mean resting state. The illuminated one of the LEDs **284a–284p** of the measured inspiration flow display portion **284** indicates the patient's present inspiration flow. The patient is instructed to breathe in a manner which causes the measured inspiration flow display portion **284** to illuminate the one of the LEDs **284d–284l** which corresponds to (such as by horizontal alignment) with the illuminated one of the target LEDs **286d–286l**. That is, the patient is instructed to breathe so as to cause the measured display portion **284** to match, or follow the target display portion **286**.

It will be appreciated by those of ordinary skill in the art that, alternatively, more than one of the LEDs in each of the display portions **284**, **286** may be illuminated by the processor **274** at any given time. In particular several adjacent LEDs in each of the display portions **284**, **286** may be illuminated. With such an arrangement, the display portions **284**, **286** display the measured and target inspiration flows in bar graph patterns.

In the illustrative embodiment, the range of inspiration flow from greatest rate of inhalation to greatest rate of exhalation is distributed equally among each LED of the display portions **284**, **286**. However, it will be appreciated by those of ordinary skill in the art that other distributions may be implemented. As one example, the LED resolution may be greater near the predetermined maximum level I_p and the predetermined minimum level E_p (i.e., difference between inspiration flow levels represented by adjacent LEDs near the I_p and E_p levels is smaller than in other regions of the displays).

The circuitry which controls and actuates the LEDs of the display **282** is substantially identical to like circuitry which controls and actuates the LEDs of display **18** (FIG. 4). It will be appreciated by those of ordinary skill in the art, however, that various modifications and alternatives to the display circuitry of FIG. 4 are possible while still achieving the benefits of the subject invention.

Referring also to FIG. 10, a flow diagram illustrates operation of the processor **274** in implementing the above-described inspiration flow feedback system **250**. The process begins in step **290**, following which an operator inputs a target number of seconds per breathing cycle in step **292**, for example through user interface **266** (FIG. 8). As one example, in performing the metronomic deep breathing test, the operator inputs ten in order to prompt the patient to breathe at a rate of 0.1 Hz. In step **294**, the time which has lapsed since the start of the test is determined. With this information, the processor **274** computes where in a par-

ticular target inspiration flow pattern the patient's inspiration flow should be in order to determine which target inspiration LED **286d–286l** to illuminate.

In step **296**, the appropriate element on the target display **286** is illuminated. In particular, the processor **274** illuminates the appropriate LED by providing data input signals at the appropriate logic levels, such as with the use of the above table and according to an inspiration flow range assigned to each LED **286d–286l** as described below in conjunction with the calibration flow diagram of FIG. 12.

The actual inspiration breath flow is measured by sampling the amplifier output signal **256** (FIG. 8) in step **298**. Thereafter, in step **300**, the processor **274** activates the appropriate LED of the measured display portion **284** in accordance with the value of the digital signal **262** and the inspiration flow range assigned to each LED **284a–284p** during the calibration process described below. As discussed, the patient is instructed to breathe so as to cause the measured inspiration flow which is fed back to the patient on display portion **284** to match the target inspiration flow. Process steps **292–300** are repeated for the duration of the inspiration measurement.

It will be appreciated by those of ordinary skill in the art that the sequence of displaying the target inspiration flow and the measured inspiration flow can be readily varied. More particularly, steps **296** and **300** are independently controlled and synchronized by the processor **274**. Steps **296** and **300** may or may not occur substantially simultaneously. However, steps **296** and **300** are synchronized so that the displayed target flow and measured flow correspond to the same time after the testing has commenced. Further, while the patient's inspiration flow is generally measured at a relatively high rate, such as on the order of 500 samples/second, updating the measured inspiration flow display portion **284** at this rate would be counterproductive since a patient could not modulate his or her breathing fast enough to follow such a rapidly changing display. Thus, the measured inspiration flow signal may be buffered by the processor **274** and be displayed at a much slower rate, such as on the order of 30 samples/second.

The metronomic deep breathing test used in heart rate variability assessment systems requires a patient to inhale to a percentage of the patient's lung capacity, such as 80%, for a predetermined duration, such as 5 seconds and then to exhale to the patient's mean resting state, for the predetermined duration at a predetermined frequency, such as on the order of 6 breaths/minute, or 0.1 Hz. The accuracy and repeatability of the metronomic deep breathing test benefit significantly from the described inspiration flow feedback.

In accordance with a feature of the invention, in process step **302**, the measured inspiration flow signal is integrated to compute the inspiration volume signal. The inspiration volume is used to calibrate the display **282** when performing the metronomic deep breathing test as will be described in conjunction with FIG. 12.

The measured inspiration flow data may be validated by determining whether or not the patient followed the prescribed breathing pattern to within a predetermined tolerance. In the illustrative metronomic deep breathing test, the computed volume is processed for this purpose as follows. Six peaks of the measured volume signal are averaged and the result is compared to 80% of the patient's maximum lung capacity to ensure that the patient was inhaling to the necessary extent. Also, the breath frequency may be computed to determine whether or not the rate of breathing was within a predetermined tolerance of the target 0.1 Hz. One illustrative way to determine the sufficiency of the breath

rate is to average the frequency of several breath cycles and compare the result to the desired 0.1 Hz. As one example, if the patient's volume signal over six breaths is within $\pm 15\%$ of the target 80% and the breath frequency is within $\pm 5\%$ of the desired 0.1 Hz, then the measured inspiration flow data is determined to be valid.

In subsequent step **304**, it is determined whether the test is complete. Typically, the patient's inspiration flow is monitored over a predetermined interval measured by a timer associated with the processor **274** according to the particular test being performed. If the test is not yet complete, then the process is repeated starting at step **294**. Alternatively, the process is terminated in step **306**.

Referring also to FIG. **11**, three illustrative command signals for controlling the target inspiration flow display portion **286** are shown. As noted above, preferably, the target inspiration flow follows a predetermined pattern, such as a mathematical pattern. Illustrative command signal **350** is a trapezoidal signal according to which the patient is instructed to inhale to a predetermined target inhalation rate I_p and then to exhale at a predetermined exhalation rate E_p . According to this target inspiration flow command signal, the uppermost target LED **286d** is illuminated from time t_1 – t_2 and the lowermost target LED **286l** is illuminated from time t_3 – t_4 . Between times t_2 and t_3 , the target LEDs **286e**–**286k** are sequentially illuminated and between times t_4 and t_5 , the target LEDs **286k**–**286e** are sequentially illuminated.

In the metronomic deep breathing test, the ideal target inspiration flow pattern is a square wave signal. However, since it is felt that it would be difficult for a patient to follow a display that toggles substantially instantaneously from uppermost LED being illuminated to lowermost LED being illuminated, a trapezoidal or triangular waveform for the target display may be preferred. If such a trapezoidal or triangular waveform is used, the target inhalation flow level I_p and exhalation flow E_p are increased and decreased, respectively, in order to compensate for the loss of inspiration flow during the transition times from the uppermost to the lowermost target display LED (e.g., from time t_2 to t_3 and time t_4 to t_5).

An alternative command signal **354** for the target display portion **286** follows a sine wave function. A further alternative command signal **358** is provided in the form of a chirp function in which the frequency of the signal increases with time, as shown. Still further, the command signal for the target display portion may be a combination of two or more predetermined functions, such as a sine wave function, a square wave function, a trapezoidal function, or a chirp function.

Referring to FIG. **12**, a method for calibrating the display **282** of FIG. **8** is illustrated. The process begins in step **360** following which an inspiration flow reference level is measured in step **364**. The reference level is simply the measured inspiration flow signal when the patient is not breathing into the patient interface **252**. This becomes the "zero" breath flow rate and its value is stored by the processor **274** in memory **270**.

In step **368**, the patient is instructed to inhale as deeply as he or she is capable and the resulting flow signal is measured by the inspiration flow amplifier **254**. Subsequently, in step **370**, the measured inspiration flow signal is converted to an inspiration volume signal. This is achieved by integrating the measured inspiration flow signal over the duration that the flow signal was measured. The resulting inspiration volume signal represents a maximum lung volume capacity and is then stored in memory **270** by processor **274**.

In step **374**, the maximum lung capacity is used to calculate calibration constants which include a multiplier and an offset constant used to convert the digital version **262** of the amplifier output signal **256** into a relative measure of the patient's inspiration volume. More particularly, the offset constant is provided by the flow signal reference level measured in step **364** and the multiplier is a value calculated to permit the measured inspiration flow to be converted into the inspiration flow scale represented by the measured flow display portion **284**.

In step **378**, the maximum lung volume is used to calculate a deep breathing maximum for use when performing metronomic deep breathing tests and the deep breathing maximum is stored in memory **270**. In particular, the deep breathing maximum is approximately 80–85% of the patient's maximum lung volume.

In step **380**, the deep breathing maximum volume is used to calculate a target inhalation rate I_p (FIG. **11**) and a target exhalation rate E_p (FIG. **11**). In the illustrative metronomic deep breathing example, given a deep breathing maximum volume 3 liters, and a desired breath frequency of 0.1 Hz, the resulting target inspiration flow I_p would be to 2.4 liters/5 seconds and the target exhalation rate E_p would be—2.4 liters/5 seconds.

In step **384**, the top LED **284a** of the measured inspiration flow display portion **284** is assigned to illuminate whenever the measured inspiration flow exceeds the target inhalation flow I_p by a predetermined amount. In step **386**, the LED **284p** is assigned to illuminate whenever the measured inspiration flow is less than the target exhalation flow E_p by a predetermined amount. These predetermined amounts are a function of the total number of target elements used to span the I_p to E_p range and the total number of measured display LEDs and are selected so that the measured display elements **284d**, **284l** represent the target inhalation rate I_p and target exhalation rate E_p , respectively. In step **390**, a zero, or reference LED **284h** is assigned to illuminate whenever the measured inspiration flow matches the reference or zero breath flow. In step **394**, the range of inspiration flow represented by illumination of each of the remaining display elements **284b**–**284o** and **286b**–**286o** is determined. In particular, the total flow rate between the maximum inhalation flow represented by LED **284a** and the maximum exhalation flow represented by LED **284p** is divided by the number of display devices, following which calibration terminates in process step **396**.

Having described the preferred embodiments of the invention, it will now become apparent to one of ordinary skill in the art that other embodiments incorporating their concepts may be used. It is felt therefore that these embodiments should not be limited to disclosed embodiments but rather should be limited only by the spirit and scope of the appended claims. All publications and references cited herein are expressly incorporated herein by reference in their entirety.

What is claimed is:

1. A system for improving patient compliance with a predetermined breathing pattern during inspiration measurements, comprising:

- (a) a device for measuring the inspiration flow of a patient;
- (b) a display comprising:
 - a first display portion for displaying the measured inspiration flow of the patient; and
 - a second display portion disposed adjacent to the first display portion for displaying a target inspiration flow; and

17

- (c) a processor responsive to the measured inspiration flow of the patient for controlling the first display portion to display at any given time the instantaneous measured inspiration flow of the patient, wherein the processor is operative to control the second display portion to display at any given time an instantaneous target inspiration flow. 5
- 2. The system of claim 1 wherein said inspiration flow measuring device measures the inspiration flow of a patient for heart rate variability analysis. 10
- 3. The system of claim 2 wherein said processor is further responsive to the measured inspiration flow for computing the inspiration volume of the patient and for processing said inspiration volume to compute a deep breathing maximum level for use in a metronomic deep breathing test. 15
- 4. A method for improving patient compliance with a predetermined breathing pattern during inspiration measurements, comprising:

18

- measuring the inspiration flow of a patient;
- displaying at any given time the instantaneous measured inspiration flow of the patient;
- displaying at any given time an instantaneous target inspiration flow; and
- instructing the patient to breathe so as to cause the measured inspiration flow to match the target inspiration flow.
- 5. The method of claim 4 further comprising:
 - computing the inspiration volume of the patient in response to the measured inspiration flow; and
 - computing a deep breathing maximum level for use in performing a metronomic deep breathing test.

* * * * *

专利名称(译)	用于在吸气测量期间增强患者顺应性的方法和设备		
公开(公告)号	US6740046	公开(公告)日	2004-05-25
申请号	US10/195956	申请日	2002-07-16
[标]申请(专利权)人(译)	KNAPP KEITHñ COHEN ALAN中号		
申请(专利权)人(译)	KNAPP KEITH N. COHEN ALAN M.		
当前申请(专利权)人(译)	波士顿医疗技术公司		
[标]发明人	KNAPP II KEITH N COHEN ALAN M		
发明人	KNAPP, II, KEITH N. COHEN, ALAN M.		
IPC分类号	A61B5/00 A61B5/11 A61B5/113 A61B5/091 A61B5/08 A61B5/0245 A61B5/087		
CPC分类号	A61B5/0809 A61B5/091 A61B5/1135 A61B5/4833 A61B5/486 A63B23/185 G06F19/3481 A63B2071/0627 A63B2230/04 A63B2230/30 A63B2230/42 G16H20/30 G16H40/67		
优先权	61/507770 2000-02-18 US		
其他公开文献	US20040015093A1		
外部链接	Espacenet USPTO		

摘要(译)

用于在吸气测量期间增强患者对预定呼吸模式的顺应性的系统利用基于吸气流量的患者反馈。测量的吸气流量显示在第一显示器上，目标吸气流量显示在第二显示器上，优选地，设置在第一显示器附近，以便于视觉比较。指示患者以使得测量的吸气流量显示匹配的方式呼吸，或者遵循目标吸气流量显示。

