



US 20080076980A1

(19) **United States**

(12) **Patent Application Publication**
Hoarau

(10) **Pub. No.: US 2008/0076980 A1**

(43) **Pub. Date: Mar. 27, 2008**

(54) **MEDICAL SENSOR FOR REDUCING SIGNAL ARTIFACTS AND TECHNIQUE FOR USING THE SAME**

(22) Filed: **Sep. 22, 2006**

Publication Classification

(75) Inventor: **Carine Hoarau, Lafayette, CA (US)**

(51) **Int. Cl. A61B 5/00 (2006.01)**

Correspondence Address:
Covidien
IP Counsel - Respiratory & Monitoring Solutions
60 Middletown Avenue
North Haven, CT 06473

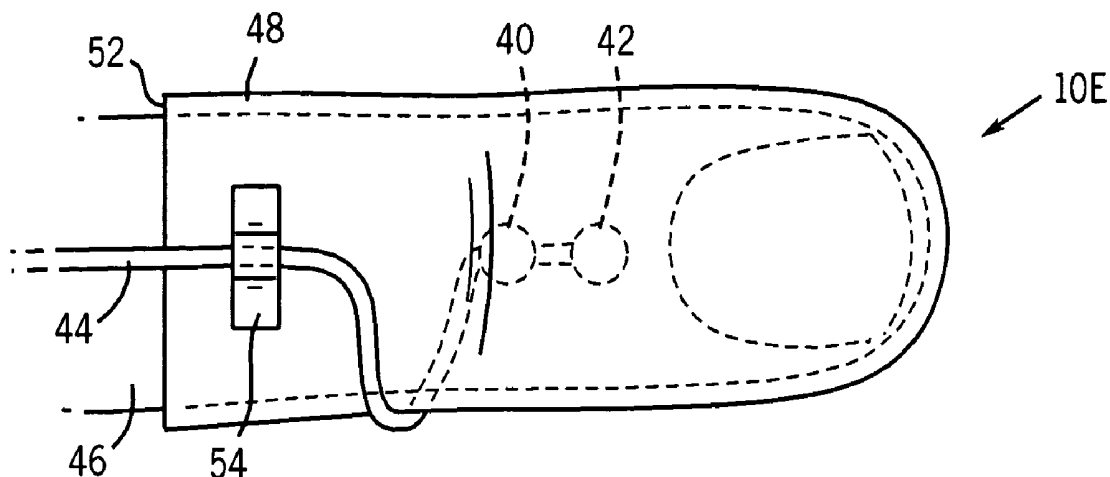
(52) **U.S. Cl. 600/310; 600/323; 600/344**

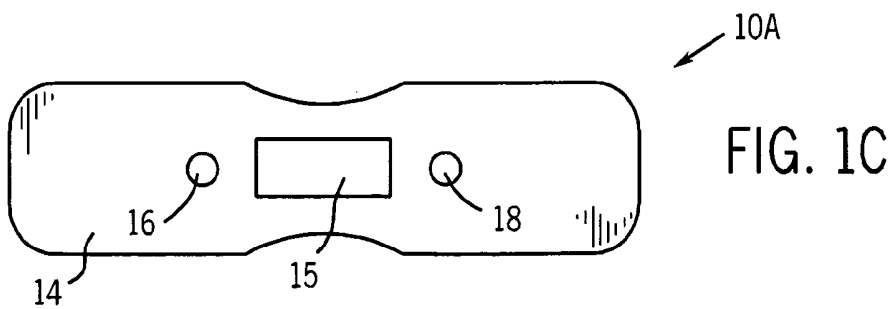
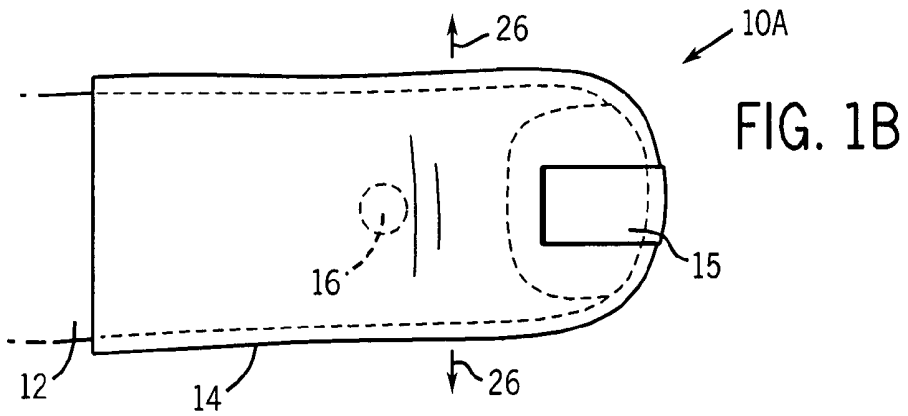
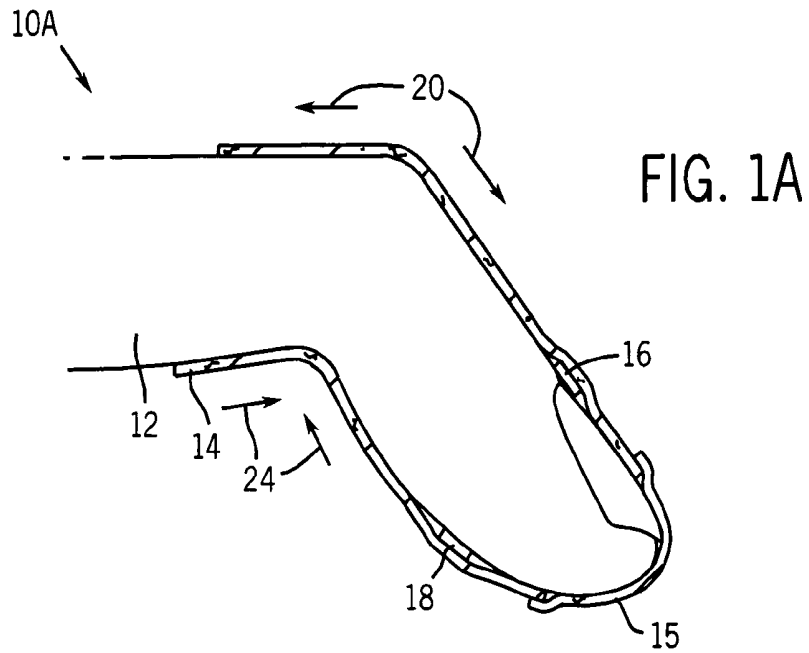
(73) Assignee: **Nellcor Puritan Bennett Incorporated**

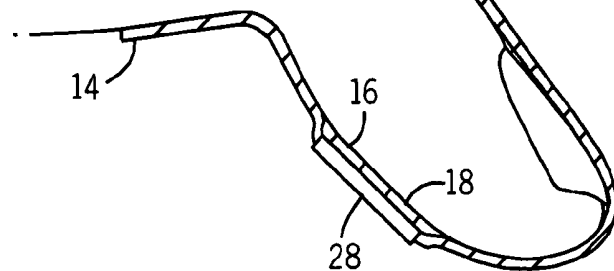
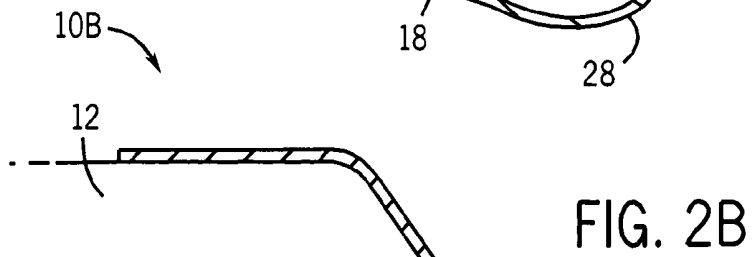
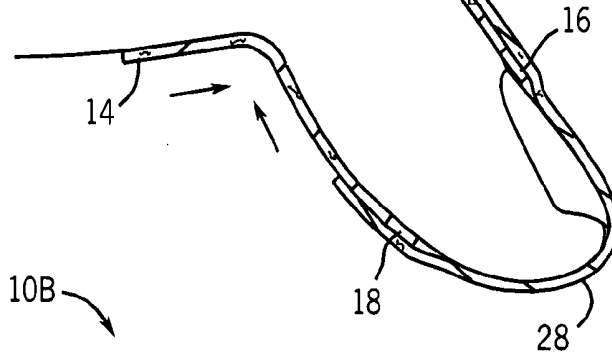
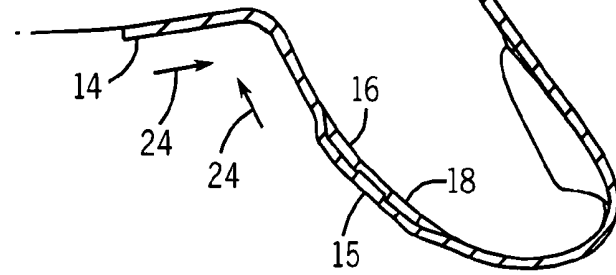
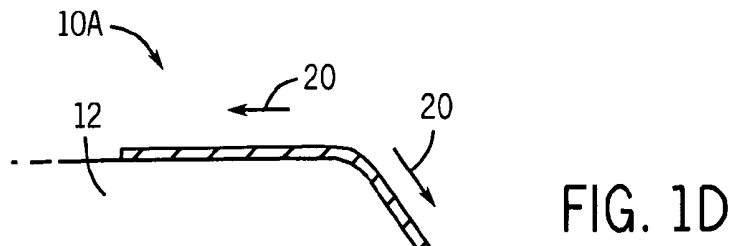
(57) **ABSTRACT**

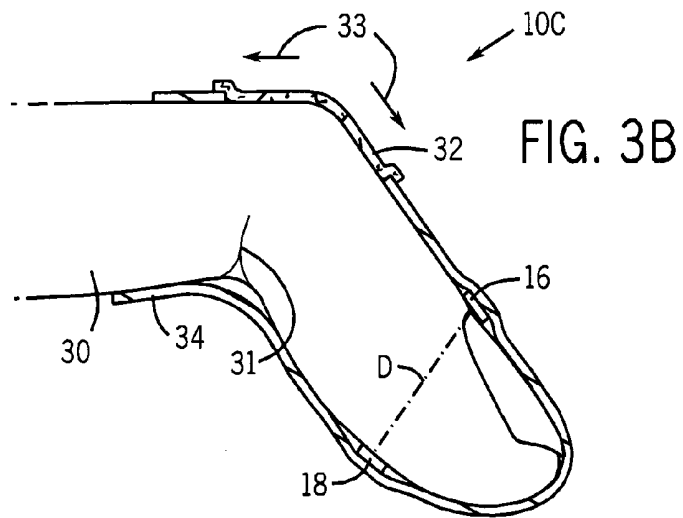
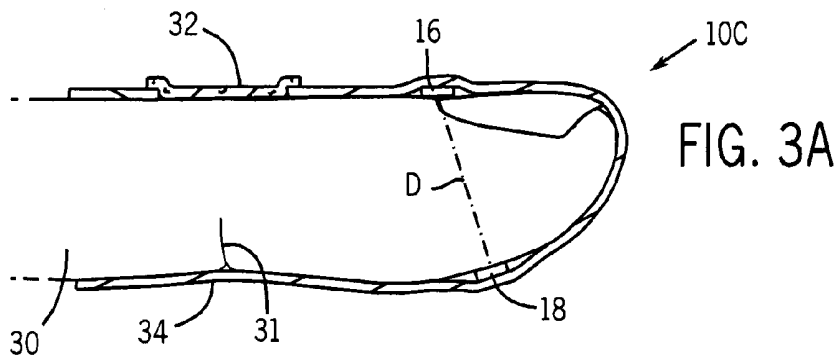
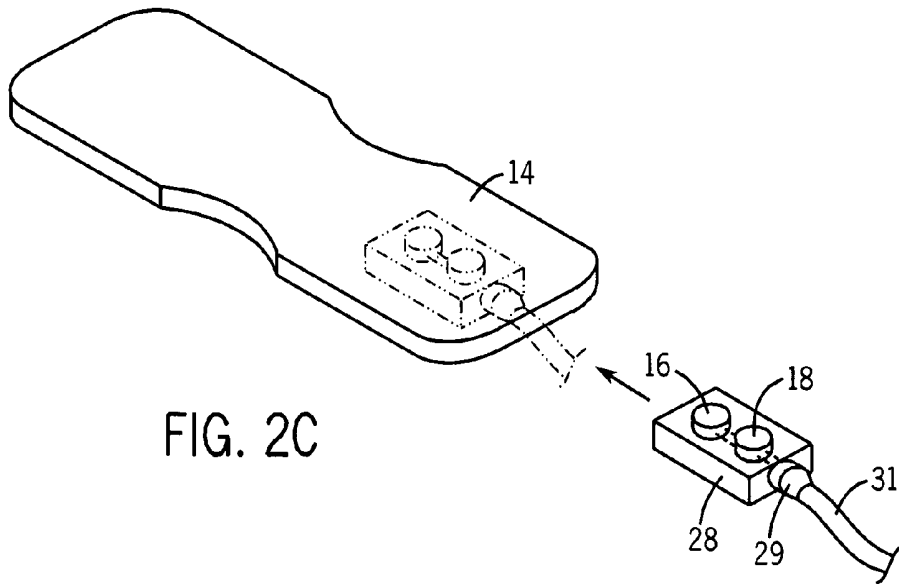
A sensor may be adapted to reduce motion artifacts by mitigating the effects of the tissue moving within the sensor. A sensor is provided with an elastomeric sensor body adapted to accommodate patient motion. Further, a sensor is provided in which the sensor cable is arranged to mitigate its pressure on a patient's tissue.

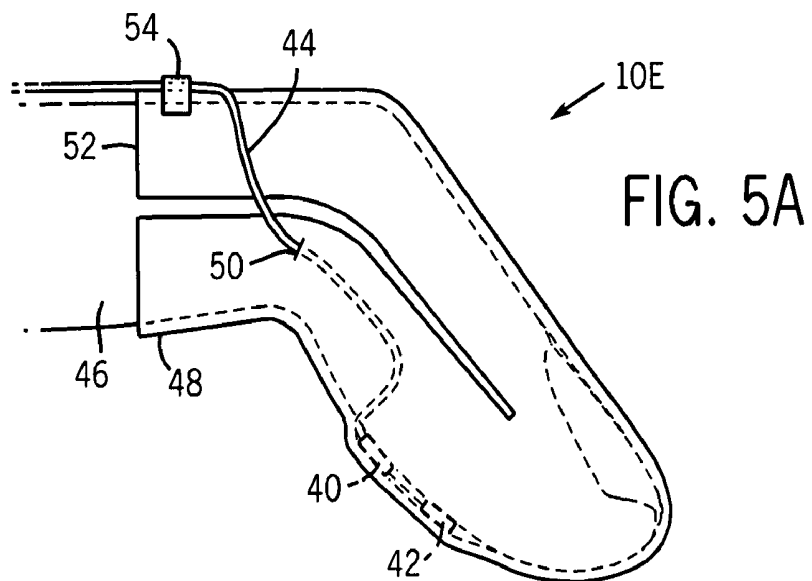
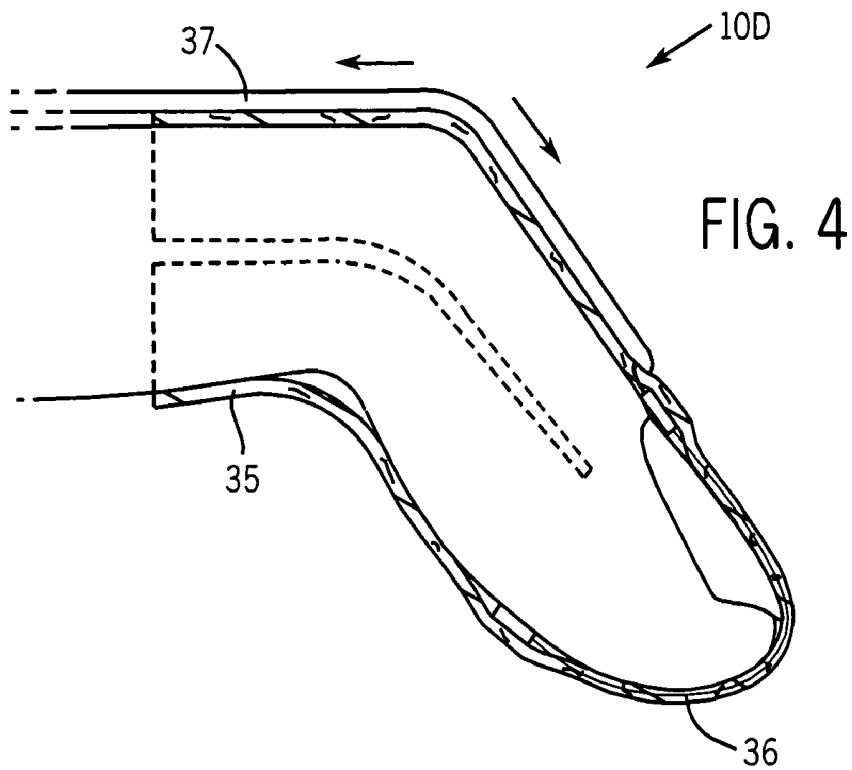
(21) Appl. No.: **11/525,396**

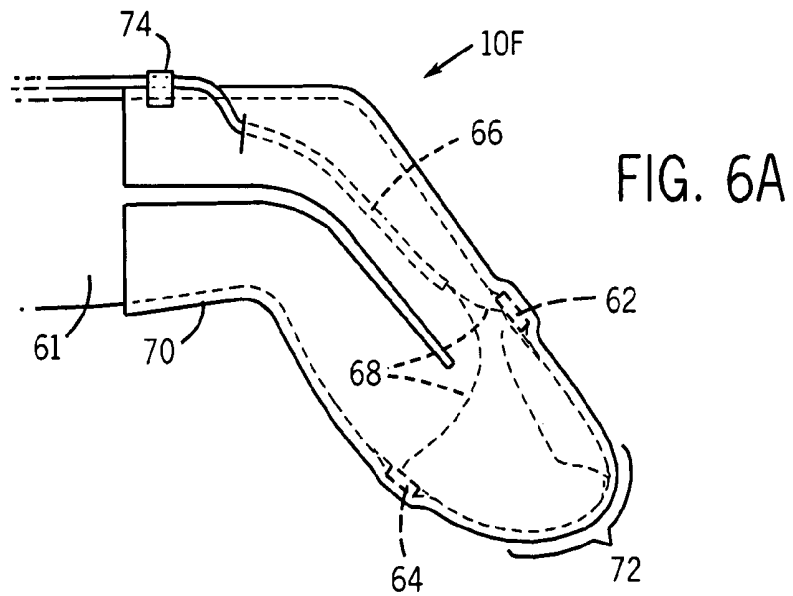
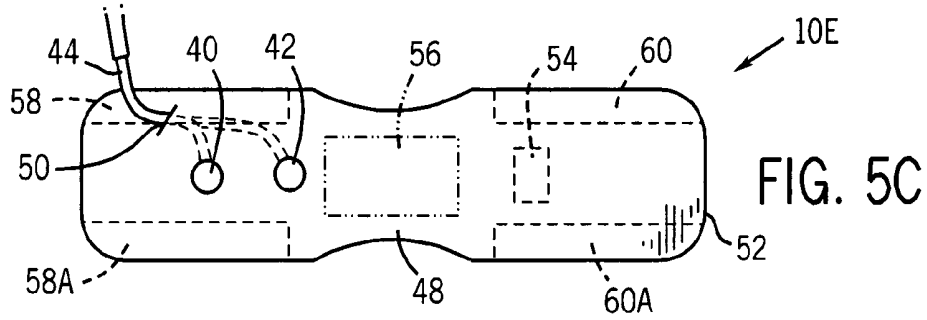
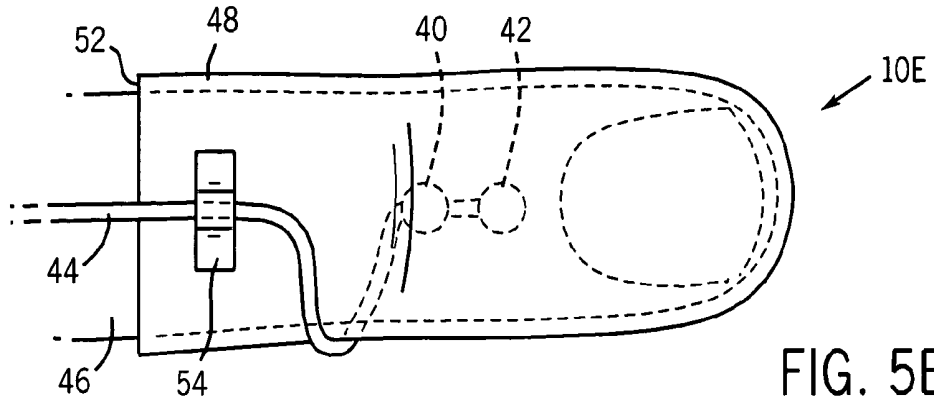












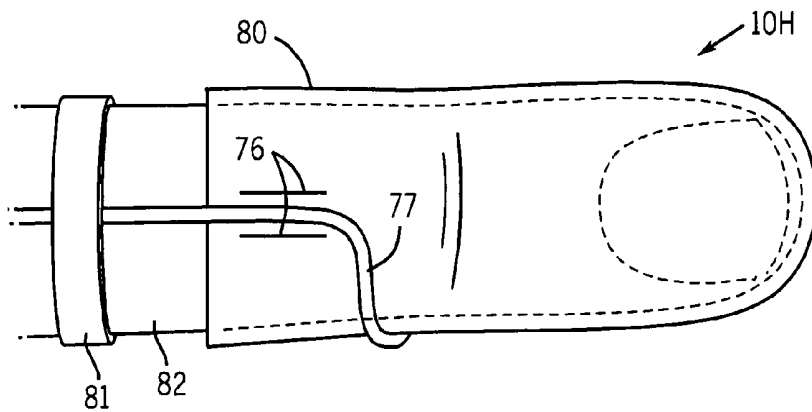
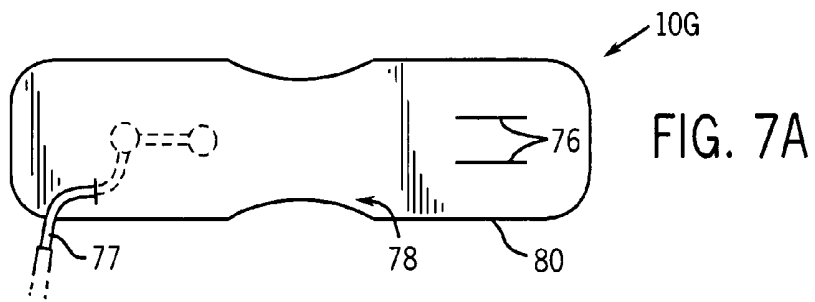
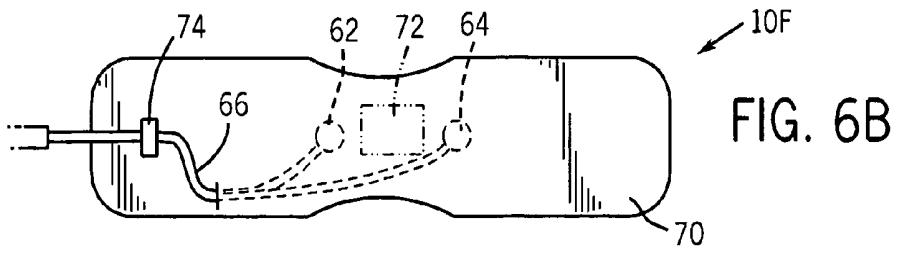


FIG. 7B

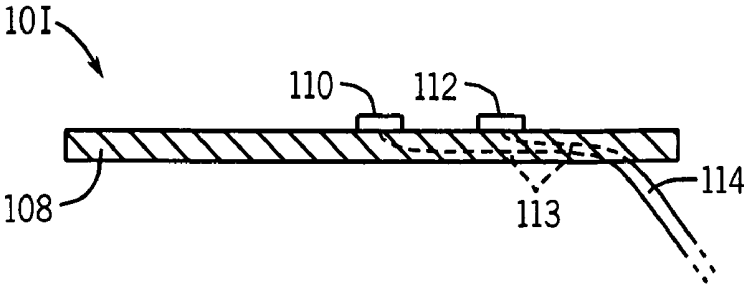


FIG. 8

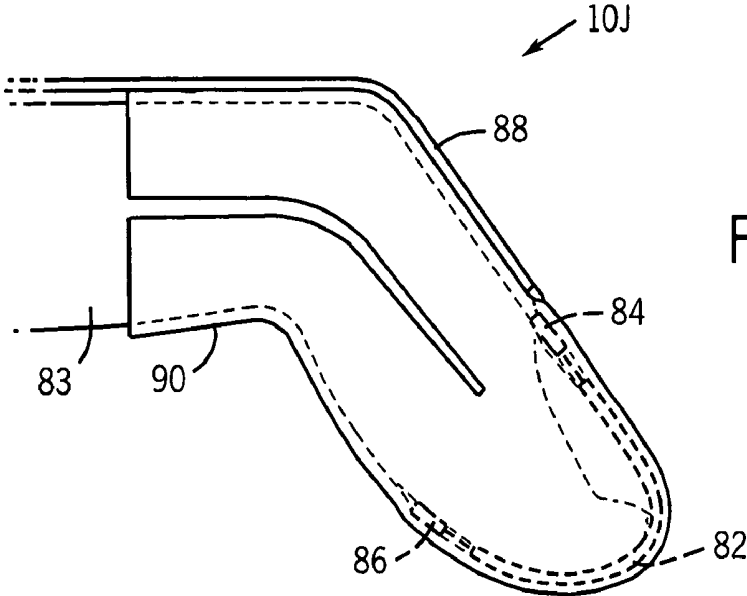


FIG. 9

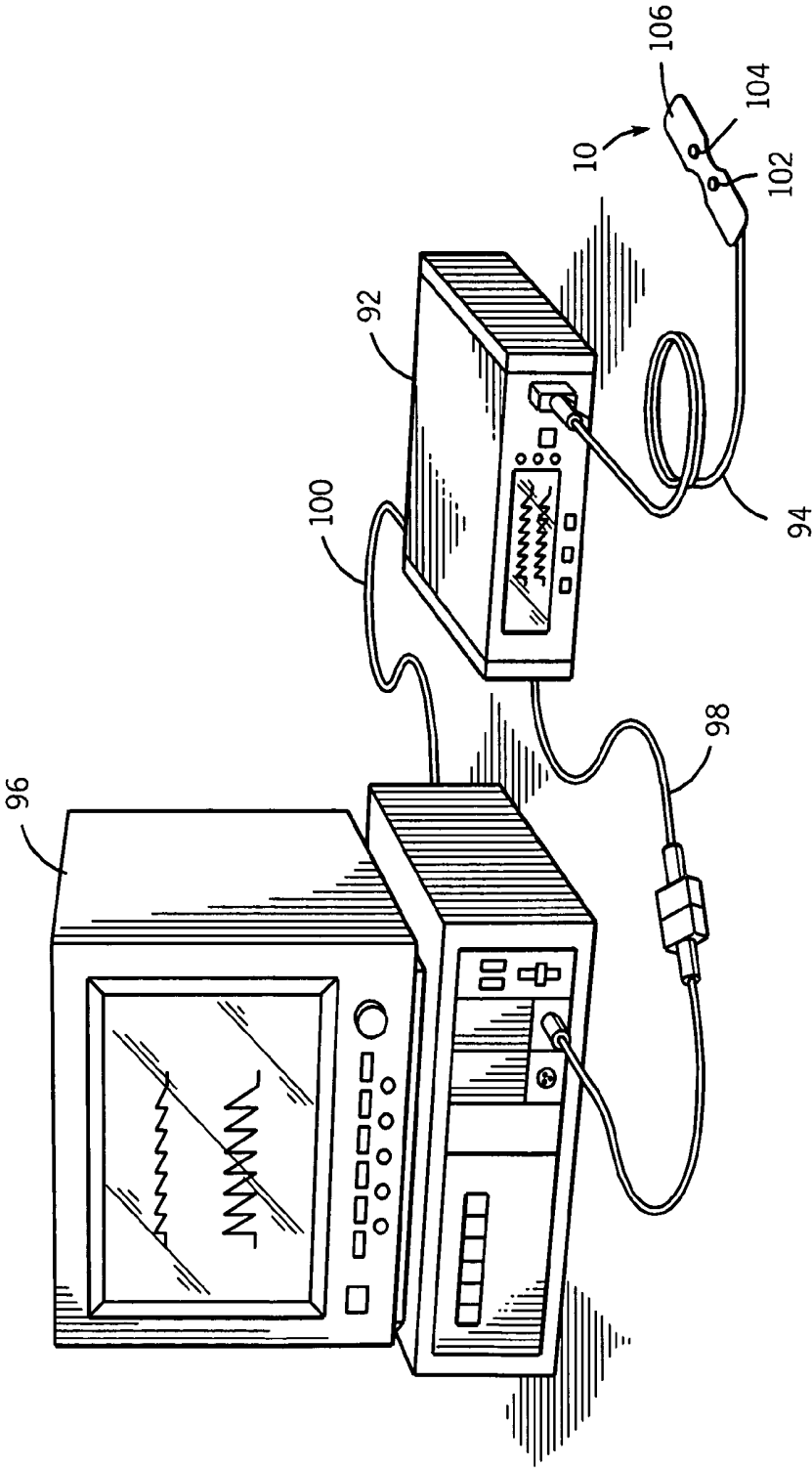


FIG. 10

**MEDICAL SENSOR FOR REDUCING
SIGNAL ARTIFACTS AND TECHNIQUE FOR
USING THE SAME**

BACKGROUND OF THE INVENTION

[0001] 1. Field of the Invention

[0002] The present invention relates generally to medical devices and, more particularly, to sensors used for sensing physiological parameters of a patient.

[0003] 2. Description of the Related Art

[0004] This section is intended to introduce the reader to various aspects of art that may be related to various aspects of the present invention, which are described and/or claimed below. This discussion is believed to be helpful in providing the reader with background information to facilitate a better understanding of the various aspects of the present invention. Accordingly, it should be understood that these statements are to be read in this light, and not as admissions of prior art.

[0005] In the field of medicine, doctors often desire to monitor certain physiological characteristics of their patients. Accordingly, a wide variety of devices have been developed for monitoring many such characteristics of a patient. Such devices provide doctors and other healthcare personnel with the information they need to provide the best possible healthcare for their patients. As a result, such monitoring devices have become an indispensable part of modern medicine.

[0006] One technique for monitoring certain physiological characteristics of a patient is commonly referred to as pulse oximetry, and the devices built based upon pulse oximetry techniques are commonly referred to as pulse oximeters. Pulse oximetry may be used to measure various blood flow characteristics, such as the blood-oxygen saturation of hemoglobin in arterial blood, the volume of individual blood pulsations supplying the tissue, and/or the rate of blood pulsations corresponding to each heartbeat of a patient. In fact, the "pulse" in pulse oximetry refers to the time-varying amount of arterial blood in the tissue during each cardiac cycle.

[0007] Pulse oximeters typically utilize a non-invasive sensor that transmits electromagnetic radiation, such as light, through a patient's tissue and that photoelectrically detects the absorption and scattering of the transmitted light in such tissue. One or more of the above physiological characteristics may then be calculated based upon the amount of light absorbed and scattered. More specifically, the light passed through the tissue is typically selected to be of one or more wavelengths that may be absorbed and scattered by the blood in an amount correlative to the amount of the blood constituent present in the tissue. The measured amount of light absorbed and scattered may then be used to estimate the amount of blood constituent in the tissue using various algorithms.

[0008] Pulse oximetry readings measure the pulsatile, dynamic changes in amount and type of blood constituents in tissue. Other events besides the pulsing of arterial blood may lead to modulation of the light path, direction, and the amount of light detected by the sensor, creating error in these measurements. Pulse oximetry measurements may be affected by various noise sources, and various types of events may cause artifacts that may obscure the blood constituent signal. For example, signal artifacts may be caused by moving a sensor in relation to the tissue, by

increasing or decreasing the physical distance between emitters and detectors in a sensor, by changing the direction of emitters or detectors with respect to tissue or each other, by changing the angles of incidence and interfaces probed by the light, by directing the optical path through different amounts or types of tissue, or by expanding, compressing or otherwise altering tissue near a sensor. In the emergency room, critical care, intensive care, and trauma center settings, where pulse oximetry is commonly used for patient monitoring, the wide variety of sources of motion artifacts includes moving of a patient or the sensor by healthcare workers, physical motion of an unanaesthetised or ambulatory patient, shivering, seizures, agitation, response to pain and loss of neural control. These motions oftentimes have similar frequency content to the pulse, and may lead to similar or even larger optical modulations than the pulse.

[0009] Two categories of pulse oximetry sensors in common use may be classified by their pattern of use: the disposable and the reusable sensor. Disposable sensors are typically flexible bandage-type structures that may be attached to the patient with adhesive materials, providing a contact between the patient's skin and the sensor components. Disposable sensors have multiple advantages, including ease of conformation to the patient. However, the flexible nature of disposable sensors renders them susceptible to signal artifacts caused by mechanical deformation of the sensor, which changes the amount of light detected. Reusable sensors, often semi-rigid or rigid clip-type devices, are also vulnerable to signal artifacts. Both categories of sensors may have modulations of detected light induced by the physical motion of the sensor components with respect to each other and the tissue.

[0010] Signal artifacts may sometimes be addressed by signal processing and filtering to mitigate the effects of motion after the motion has occurred. However, signal processing algorithms to filter out motion artifacts after they have occurred may not filter out all type of artifacts. For example, certain types of regular movements, such as tapping, may not be interpreted by a signal artifact filter as noise. Thus, it would be desirable to provide a sensor that prevents, reduces the occurrence of, or mitigates movements that may lead to motion artifacts. Such a sensor may incorporate elements which enhance patient comfort without reducing the sensor's resistance to movement or outside forces.

SUMMARY

[0011] Certain aspects commensurate in scope with the originally claimed invention are set forth below. It should be understood that these aspects are presented merely to provide the reader with a brief summary of certain forms that the invention might take and that these aspects are not intended to limit the scope of the invention. Indeed, the invention may encompass a variety of aspects that may not be set forth below.

[0012] There is provided a sensor that includes: a sensor body comprising an elastic material; and an emitter and a detector disposed on the sensor body, wherein sensor body is substantially inelastic in at least part of a region of the sensor body connecting the emitter and the detector.

[0013] There is also provided a pulse oximetry system that includes: a pulse oximetry monitor; and a pulse oximetry sensor adapted to be operatively coupled to the monitor. The sensor includes a sensor body comprising an elastic mate-

rial; and an emitter and a detector disposed on the sensor body, wherein sensor body is substantially inelastic in at least part of a region of the sensor body connecting the emitter and the detector.

[0014] There is also provided a method that includes: applying a sensor body comprising an emitter and a detector to a patient's tissue; and stretching an elastic portion of a sensor body in response to a movement of the tissue, wherein the optical distance between the emitter and the detector remains substantially fixed.

[0015] There is also provided a method of manufacturing a sensor that includes: providing a sensor body comprising an elastic material; and providing an emitter and a detector disposed on the sensor body, wherein sensor body is substantially inelastic in at least part of a region of the sensor body connecting the emitter and the detector.

[0016] There is also provided a sensor that includes: a sensor body adapted to expand in response to a biasing force; and an emitter and a detector disposed on the sensor body, wherein the sensor body is adapted to fix the optical distance between the emitter and the detector.

[0017] There is also provided a sensor that includes: a sensor body comprising at least one elastic electronic component; and an emitter and a detector disposed on the sensor body.

[0018] There is also provided a system that includes: a monitor; and a sensor adapted to be operatively coupled to the monitor, the sensor including: a sensor body comprising at least one elastic electronic component; and an emitter and a detector disposed on the sensor body.

[0019] There is also provided a method of response to movement of a sensor that includes: applying a sensor body comprising an emitter and a detector to a patient's tissue; and stretching an elastic electronic component of a sensor body in response to a movement of the tissue, wherein the optical distance between the emitter and the detector remains substantially fixed.

[0020] There is also provided a method of manufacturing a sensor, including: providing a sensor body comprising at least one elastic electronic component; and providing an emitter and a detector disposed on the sensor body.

[0021] There is also provided a sensor that includes: a sensor body; an emitter and a detector disposed on the sensor body; and an electronic component operatively connected to the emitter or the detector adapted to expand in response to a biasing force.

[0022] There is also provided a sensor that includes: a sensor body comprising an exterior surface and a tissue-contacting surface; at least one sensing element disposed on the sensor body; a cable adapted to be electrically coupled to the sensing element; and a cable guide disposed on exterior surface of the sensor body, wherein the cable guide is adapted to hold the cable in a predetermined position on the sensor body.

[0023] There is also provided a pulse oximetry system that includes: a pulse oximetry monitor; and a pulse oximetry sensor adapted to be operatively coupled to the monitor. The sensor includes: a sensor body comprising an exterior surface and a tissue-contacting surface; at least one sensing element disposed on the sensor body; a cable adapted to be electrically coupled to the sensing element; and a cable guide disposed on exterior surface of the sensor body, wherein the cable guide is adapted to hold the cable in a predetermined position on the sensor body.

[0024] There is also provided a method that includes: applying a sensor body comprising a sensing component to a patient's tissue; and securing a sensor cable that is operatively connected to the sensing component in a predetermined position on a sensor body with a cable guide.

[0025] There is also provided a method of manufacturing a sensor that includes: providing a sensor body comprising an exterior surface and a tissue-contacting surface; providing at least one sensing element disposed on the sensor body; providing a cable adapted to be electrically coupled to the sensing element; and providing a cable guide disposed on the exterior surface of the sensor body, wherein the cable guide is adapted to hold the cable in a predetermined position on the sensor body.

[0026] There is also provided a sensor that includes: a sensor body; at least one sensing element disposed on the sensor body; and a cable adapted to be electrically coupled to the sensing element, wherein the cable is disposed along the sensor body in a curvilinear configuration.

[0027] There is also provided a system that includes: a monitor; and a sensor adapted to be operatively coupled to the monitor. The sensor includes: a sensor body; at least one sensing element disposed on the sensor body; and a cable adapted to be electrically coupled to the sensing element, wherein the cable is disposed along the sensor body in a curvilinear configuration.

[0028] There is also provided a method that includes: electrically coupling a sensing element to a monitor with a cable, wherein sensing element is disposed on the sensor body and wherein the cable is disposed along the sensor body in a curvilinear configuration.

[0029] There is also provided a method that includes: providing a sensor body; providing at least one sensing element disposed on the sensor body; and providing a cable adapted to be electrically coupled to the sensing element, wherein the cable is disposed along the sensor body in a curvilinear configuration.

[0030] There is also provided a sensor that includes: an emitter and a detector disposed on a substantially rigid substrate, wherein the substantially rigid substrate is adapted to hold the emitter and detector at a substantially fixed optical distance relative to one another when the sensor is applied to a patient.

[0031] There is also provided a system that includes: a monitor; and a sensor adapted to be operatively coupled to the monitor. The sensor includes: an emitter and a detector disposed on a substantially rigid substrate, wherein the substantially rigid substrate is adapted to hold the emitter and detector at a substantially fixed optical distance relative to one another when the sensor is applied to a patient.

[0032] There is also provided a method that includes: fixing the optical distance between an emitter and a detector relative to one another, wherein the emitter and the detector are disposed on a substantially rigid substrate.

[0033] There is also provided a method of manufacturing a sensor that includes: providing a substantially rigid substrate on which an emitter and a detector are disposed, wherein the substantially rigid substrate is adapted to hold the emitter and the detector at a substantially fixed optical distance.

BRIEF DESCRIPTION OF THE DRAWINGS

[0034] Advantages of the invention may become apparent upon reading the following detailed description and upon reference to the drawings in which:

[0035] FIG. 1A illustrates a cross-sectional view of an exemplary embodiment of a transmission-type bandage-style sensor with an elastic sensor body;

[0036] FIG. 1B illustrates a top view of the sensor of FIG. 1A applied to a patient digit;

[0037] FIG. 1C illustrates a perspective view the sensor of FIG. 1A;

[0038] FIG. 1D illustrates a cross-sectional view of an alternative embodiment of a sensor using reflectance-type sensing elements;

[0039] FIG. 2A illustrates a cross-sectional view of an exemplary embodiment of an elastic transmission-type bandage-style sensor applied to a patient's digit, whereby the sensor includes a stiffening member;

[0040] FIG. 2B illustrates a cross-sectional view of an exemplary embodiment of an elastic reflectance-type bandage-style sensor applied to a patient's digit, whereby the sensor includes a stiffening member;

[0041] FIG. 2C illustrates an embodiment of the sensor of FIG. 2B, whereby the stiffening member and sensing components may be a unitary assembly;

[0042] FIG. 3A illustrates a cross-sectional view of an alternate exemplary embodiment of a bandage-style sensor with an inelastic sensor body with elastic portions disposed proximate to the finger joint;

[0043] FIG. 3B illustrates a cross-sectional view of the sensor of FIG. 3A with the finger joint flexed;

[0044] FIG. 4 illustrates a side view of an exemplary embodiment of a sensor with an elastic sensor cable;

[0045] FIG. 5A illustrates a side view of an exemplary embodiment of a sensor whereby the sensor cable is disposed along the side of the finger and secured with a cable guide;

[0046] FIG. 5B illustrates a top view of the sensor of FIG. 5A;

[0047] FIG. 5C illustrates a perspective view of the sensor of FIG. 5A;

[0048] FIG. 6A illustrates a side view of an embodiment of an exemplary sensor applied to a patient's finger with a sensor cable disposed on the sensor body in a configuration that avoids the fingertip region;

[0049] FIG. 6B illustrates a perspective view of the sensor of FIG. 6A;

[0050] FIG. 7A illustrates a perspective view of an embodiment of an exemplary sensor with alignment indices for the sensor cable;

[0051] FIG. 7B illustrates a top view of the sensor of FIG. 7A applied to a patient's finger and secured with adhesive bandages such that the sensor cable is aligned with the alignment indices;

[0052] FIG. 8 illustrates a cross-sectional view of an embodiment of an exemplary sensor with a sensor cable that extends at an angle away from the sensor body;

[0053] FIG. 9 illustrates a side view of an embodiment of an exemplary sensor with a flexible circuit connecting the emitter and detector; and

[0054] FIG. 10 illustrates a pulse oximetry system coupled to a multi-parameter patient monitor and a sensor according to embodiments of the present invention.

DETAILED DESCRIPTION OF SPECIFIC EMBODIMENTS

[0055] One or more specific embodiments of the present invention will be described below. In an effort to provide a

concise description of these embodiments, not all features of an actual implementation are described in the specification. It should be appreciated that in the development of any such actual implementation, as in any engineering or design project, numerous implementation-specific decisions must be made to achieve the developers' specific goals, such as compliance with system-related and business-related constraints, which may vary from one implementation to another. Moreover, it should be appreciated that such a development effort might be complex and time consuming, but would nevertheless be a routine undertaking of design, fabrication, and manufacture for those of ordinary skill having the benefit of this disclosure.

[0056] In accordance with the present technique, sensors for pulse oximetry or other applications utilizing spectrophotometry are provided that reduce signal artifacts by reducing the occurrence of tissue deformation, such as compression or discoloration, associated with the movement of a patient's tissue relative to the sensor or the movement of the sensor elements relative to one another. For example, sensors are provided herein that include elastic materials that may accommodate patient movement. The sensors that include elastic materials are configured to reduce pressure from the sensor on the tissue during such movement. Sensors are also provided in which a sensor cable is directed or arranged in relation to the sensor body such that the pressure or weight of the cable on a patient's tissue is reduced.

[0057] Signal artifacts in pulse oximetry may be caused by patient movement, including movement of the optically probed tissue within the sensor. Although a typical conformable sensor may be sufficiently flexible to wrap around a patient's tissue, such a flexible yet inelastic sensor will nonetheless provide resistance to the tissue as it moves within the sensor. As a patient's tissue presses against an inelastic sensor's surfaces, such as the sensor body, the sensing elements, and the cable, the pressure of the sensor against the tissue may result in temporary changes to the tissue. Such changes in response to pressure include blanching of the skin, coloring of the skin due to blood pooling, creasing of the skin in response to bending at joints, and spreading or compression of the tissue. These variations in tissue geometry and color may result in signal artifacts. For example, coloring of the skin may result in increased absorption of light by the tissue that is not related to a physiological constituent. Alternatively, blanching of the skin may lead to shunting of light through exsanguinated or partially exsanguinated tissue. Additionally, although an inelastic sensor may not expand or contract in response to patient movement, such a sensor may yet be vulnerable to mechanical deformation that may change the geometry of the sensing elements relative to one another. As bandage-type inelastic sensors are generally relatively flexible, though inelastic, such sensors may twist or come away from the skin, which may alter the geometry of the sensing elements. Because medical sensors are often used in settings where it is difficult to prevent patient motion, it is desirable to provide a mechanism for reducing the effects of patient and/or sensor motion on the sensor signals.

[0058] Sensors are disclosed herein that include elastic materials and that may reduce the effect of patient motion within a sensor. FIG. 1A illustrates a cross-sectional view of an exemplary bandage-type sensor 10A appropriate for use on a patient's finger 12. The sensor 10A has an elastic sensor body 14. The elastic sensor body 14 may accommodate

movement of the finger 12 with the sensor 10A. An inelastic portion 15 disposed on the sensor body in a region between the emitter 16 and the detector 18 may serve to reduce or eliminate changes in the optical distance due to stretching of the elastic sensor body 14.

[0059] The inelastic portion 15 does not stretch in response to the patient movement, and thus the accommodation of the patient movement by the elastic sensor body 14 may have a reduced effect or no effect on the position of the emitter 16 and the detector 18 relative to one another, as discussed in more detail below. As depicted, the finger 12 is flexed, causing the elastic sensor body 14 to stretch and expand, indicated by arrows 20, in an area corresponding to the nail side of the finger joint. In the area corresponding to the palm side of the finger joint 22, the elastic sensor body may contract, as indicated by arrows 24. As shown in FIG. 1B, a top view of the sensor 10A, the elastic sensor body 14 may also stretch to accommodate spreading of the tissue in the fingertip region of the finger during flexing, indicated by arrows 26. Alternatively, in other embodiments (not shown) the tissue in the fingertip region may spread or expand when the finger 12 is pressed against a rigid object. Hence, as the finger 12 moves, the elastic sensor body 14 is able to conform to the tissue as it changes shape while the inelastic portion 15 provides stability to the emitter 16 and the detector 18. FIG. 1C is a top view of the sensor 10A showing the inelastic portion 15 in the region of the sensor body 14 between the emitter 16 and the detector 18. In an alternative embodiment, the sensor 10A may be a reflectance-type sensor, as shown in FIG. 1D. In such an embodiment, the emitter 16 and the detector 18 are positioned side-by-side. Such a sensor may provide certain advantages. For example, the emitter 16 and the detector 18 may be manufactured as a single, smaller part as compared to a transmission-type sensor.

[0060] The term elastic as used herein may describe any material that, upon application of a biasing force, is able to be stretched at least about 100% (i.e., to a stretched, biased length that is at least about 100% of its relaxed unbiased length). Many elastic materials may be elongated by much more than 400% and may, for example, be elongated at least 500%, 600% or more. Further, upon release of the biasing force, the elastic material is able to substantially recover its unbiased length. In certain embodiments, upon release of the biasing force, the elastic material returns to a length that is 120% or less of its original unbiased length. For example, a hypothetical elastic material that is one inch in length is able to be stretched to at least 2.00 inches, and when the stretch is released, the material return to a length that is less than 1.20 inches. Exemplary elastic materials may include spandex or spandex blends. Another appropriate elastomer is Rx715P, available from Scapa (Windsor, Conn.). In certain embodiments, it is contemplated that the elastic material may be a woven or knit material. In one embodiment, the elastic material may be woven or otherwise configured such that the material has a one-way stretch along a single axis. For example, a one-way elastic material may stretch lengthwise down the finger over the joints as the finger is bent. In other embodiments, the elastic material may be an elastomer, such as a polymer-based material. Appropriate materials also include natural rubber, silicone rubber, neoprene, and synthetic polymers.

[0061] In certain embodiments, sensors that include elastic materials may provide a compressive force to the tissue to

which they are applied. The compressive force provided by a sensor according to the present techniques can be varied to provide an appropriate level of pressure to the tissue. In certain embodiments, a sensor including an elastic material may provide sufficient pressure to the tissue so that the applied pressure exceeds the typical venous pressure of a patient, but does not exceed the diastolic arterial pressure. A sensor that applies a pressure greater than the venous pressure may squeeze excess venous blood from the optically probed tissue, thus enhancing the sensitivity of the sensor to variations in the arterial blood signal. Since the pressure applied by the sensor is designed to be less than the arterial pressure, the application of pressure to the tissue does not interfere with the arterial pulse signal. Typical venous pressure, diastolic arterial pressure and systolic arterial pressure are typically less than 10-35 mmHg, 80 mmHg, and 120 mmHg, respectively, although these pressures may vary because of the location of the vascular bed and the patient's condition. In certain embodiments, the sensor may be adjusted to overcome an average pressure of 15-30 mmHg. In other embodiments, low arterial diastolic blood pressure (about 30 mmHg) may occur in sick patients. In such embodiments, the sensor may remove most of the venous pooling with light to moderate pressure (to overcome about 15 mmHg).

[0062] Sensors that include elastic materials as described herein may also include an inelastic portion 15 disposed on the sensor body that may reduce or eliminate changes in optical distance between the sensing elements due to sensor bending or stretching in response to movement. The inelastic portion 15 may include any substantially inelastic material and relatively inflexible material, including substantially inelastic stiffened paper, metal, or polymeric material. Generally, a substantially inelastic portion is unable to be elongated 50% or more of its total length. Thus, a hypothetical inelastic material one inch in length is not able to be stretched elastically to 1.50 inches or more without causing damage or permanent deformation to the material.

[0063] The inelastic portion 15 may provide stability to the emitter 16 and detector 18 by mitigating the effects of stretching the elastic sensor body 14 on the optical distance. Reducing or controlling changes in the optical distance may include reducing any change in position or geometry of the sensing elements of a sensor. More specifically, a change in optical distance may involve any change in optical geometry, such as a change in the path length, a change in the relative angle of the sensing elements relative to one another, and/or a change in the angle of the sensing elements relative to the tissue. As sensors do not typically emit nor detect light omnidirectionally, any motions that lead to variations in angle of sensor components may alter the amount of light detected, and may force detected light through different portions of tissue. In any case, variability in the optical path length can cause signal artifacts and obscure the desired pulse oximetry signal. Thus, it is desirable that a sensor's emitter(s) and detector(s) experience a minimum of movement relative to one another and relative to the patient's tissue.

[0064] In an alternate embodiment, a cross-sectional view of an elastic sensor 10B is illustrated in FIG. 2A in which an inelastic portion of the sensor 10B includes a stiffening member 28. The stiffening member 28 is disposed on an elastic sensor body 14 in a region between the emitter 16 and detector 18. The stiffening member 28 may be constructed

from any suitable material that functions to hold the emitter **16** and the detector **18** at a substantially fixed optical distance when the sensor **10B** is applied to a patient. For example, a suitable stiffening member **28** may be metal, plastic or polymeric material, or cardboard. In certain embodiments, suitable metals include aluminum or brass. The stiffening member **28** may be in the shape of a strip, wire, or mesh that can be easily adapted for use with an elastic sensor body **14**. The stiffening member **28** may be adapted to be bent, shaped, activated, or applied to a conformable elastic sensor body **14** in order to hold an emitter **16** and a detector **18** at a substantially fixed optical distance. The stiffening member **28** may be sized to form a strip that is generally in the area surrounding the emitter **16** and the detector **18**. A stiffening member **28** need not be solid, but may also be a fluid or other non-solid material that stabilizes the optical distance between an emitter **16** and a detector **18**. For example, a stiffening member **28** may include a bladder that is adapted to hold a fluid. In certain embodiments, it may be desirable to employ a gas or gas mixture as part of the stiffening member **28** for reasons related to cost, manufacturing convenience, and total sensor weight.

[0065] FIG. 2B illustrates an embodiment in which the sensor **10B** is configured to be in reflectance mode. In certain embodiments, the emitter **16** and the detector **18** may both be disposed on or within the stiffening member **28**, as shown in FIG. 2C. In FIG. 2C, a sensing component assembly **25** is formed by the emitter **16** and detector **18**, which are embedded in the stiffening member **28** and are connected to a cable **31** by wires **29**. The sensing component assembly **25** may be disposed on the elastic sensor body **14**, adhesively or otherwise. In an alternate embodiment (not shown), the sensing component assembly **25** may be applied to a patient's tissue with elastic tape or bandages.

[0066] In certain embodiments, a sensor may include elastic materials only in specific portions of the sensor. For example, it may be desirable to design a finger sensor with elastic portions that correspond to areas of a finger that are likely to move, such as joints. FIG. 3A illustrates a bandage-type sensor **10C** applied to a patient's finger **30**. The sensor **10C** includes an elastic portion **32** disposed on an inelastic sensor body **34**. The elastic portion **32** corresponds to the top of a finger joint **31**. As depicted in FIG. 3B by arrows **33**, when the finger **30** bends at the joint **31**, the elastic portion **32** stretches to accommodate the movement. However, the optical distance, indicated by dashed line "D", between the emitter **16** and the detector **18** remains substantially fixed.

[0067] It should be understood the ratio of elastic portions and inelastic portions of a sensor body may be varied according to the activity level of the patient wearing the sensor. For example, for a very active patient, it may be advantageous to apply a sensor having more elastic portions, such as a ratio of elastic portions to inelastic portions of greater than one. In certain embodiments, it is contemplated that total elastic surface area of a sensor body may be at least about 5%, and typically in a range from about 10% to about 95%.

[0068] In certain embodiments, a sensor may include elastic electrical components, including sensor cable components or wires. FIG. 4 illustrates a side view of a sensor **10D** with an elastic cable **37** disposed on the sensor body **35**. As the finger flexes, the elastic cable **37** is able to accommodate the flexing motion. The elastic electrical components,

such as the elastic cable **37**, may include transducers and/or electronic circuits integrated onto an elastic polymer that include elastic metal that remain electrically conducting even under large and repeated stretching and relaxation. Suitable elastic polymeric materials include silicone rubber, such as polydimethyl siloxane (PDMS) and acrylic rubber. Electrically conductive materials useful for elastic conductive films include metallic conducting materials such as copper, silver, gold, aluminum and the like. Alternatively, electrically conductive materials include organic conducting materials such as polyaniline. Suitable electrically conductive materials include a semiconductor, either inorganic like silicon or indium tin oxide, or organic-like pentacene or polythiophene. Alternatively, the electrically conductive materials can be alloys instead of stoichiometric elements or compounds. The elastic conductive film can be formed on elastic polymeric substrate by electron beam evaporation, thermal evaporation, sputter deposition, chemical vapor deposition (CVD), electroplating, molecular beam epitaxy (MBE) or any other conventional means.

[0069] Sensors are also disclosed herein in which a sensor cable is routed away from areas of the sensor body that may be subject to tissue pressure or movement. Typically, a sensor cable is embedded in the sensor body and runs through the sensor body along an imaginary axis connecting the sensor's emitter and detector. When such a sensor is applied to a patient's finger, the cable wraps around the fingertip region and runs along the top of the digit. As the finger flexes, the relatively rigid and inelastic cable resists the flexing motion, which may result in tissue discoloration, such as reddening or exsanguinations, or deformation in the area where the tissue pushes against the cable. Similarly, when the finger taps against a rigid object, the fingertip region is pushed against the relatively rigid sensor cable, and the tissue may experience discoloration or deformation. As changes in tissue color and geometry may lead to signal artifacts, it is desirable to alter the arrangement of the sensor cable in relation to the sensor body to mitigate such signal interference.

[0070] Sensors are provided herein that include cables with non-axial or curvilinear paths in relation to the sensor body. FIG. 5A illustrates a side view reflectance-type sensor **10E** applied to a patient's finger **46**. FIG. 5B is a top view of the sensor **10E**. The emitter **40** and the detector **42** are operatively connected to a sensor cable **44**. The sensor cable **44**, rather than wrapping around the tip of the finger **46**, follows a nonlinear, i.e. non-axial, route within the sensor body **48**. The cable **44** is partially embedded in the sensor body **48**, and may emerge from the sensor body **48** at a site **50** that is not on the outer perimeter **52**. Alternatively, the site **50** may be along the outer perimeter **52**. When the cable **44** emerges from the sensor body **48**, it may be wrapped around the top of the finger **46** and secured with a cable guide **54**, as shown in FIG. 5B. The cable guide **54** may be any suitable securing mechanism, include a loop, slot, snap, adhesive, or hook and loop fastener. Further, the cable guide **54** may be elastic in certain embodiments, allowing it to stretch tightly over the cable **44** to provide a secure hold.

[0071] Generally, the cable **44** may be routed along the sensor body **48** in any configuration associated with a mitigation of signal artifacts. For example, the cable **44** may be routed along the sensor body **48**, e.g. embedded within or disposed on a surface of the sensor body **48**, to avoid the region **56** of the sensor body **48** corresponding with the

finger tip region of the finger in order to mitigate signal artifacts associated with scratching or tapping. In order to mitigate motion artifacts associated with bending at a joint, the cable 44 may be routed along the sensor body 48 to avoid the most dynamic regions of the finger 46, such as the top and bottom of the joint. In such an embodiment, the cable 44 may be routed in an area corresponding to side regions 58 and 60 of the finger 46, as shown in FIG. 5C. It should be understood that in another embodiment, the cable may be routed along the sensor body in an area corresponding to side regions 58A and 60A, corresponding to an alternative side of the finger.

[0072] Such an arrangement of the sensor cable may also be advantageous in a transmission-type sensor, in which a sensor's emitter 62 and detector 64 lie on opposing side of the tissue. FIG. 6A illustrates a sensor 10F of this type applied to a patient's finger 61. Wire leads 68 from an emitter 62 and a detector 64 converge at a sensor cable 66. FIG. 6B illustrates a perspective view of the sensor 10F. The wire leads 68 and sensor cable 66 are arranged along the sensor body 70 such that the sensor cable 66 is not disposed within a region 72 of the sensor body 70 corresponding with the fingertip region of the finger 61 in order to mitigate signal artifacts associated with scratching or tapping. The cable 66 may be wrapped around the finger 61 and secured with a cable guide 74. In an alternate embodiment (not shown), the wire leads 68, which are relatively thin, may be arranged to run along the fingertip region 72 and then along the sensor body 70 to join the sensor cable 66, which is not disposed in the fingertip region 72.

[0073] In certain embodiments, it may be advantageous for a sensor cable to be secured by a healthcare worker with tape or bandages on an appropriate location of a sensor body. FIG. 7A illustrates a sensor 10G which includes alignment indices 76 for a sensor cable 77 on a non-tissue contacting surface 78 of the sensor body 80. FIG. 7B shows the sensor 10G applied to a patient's finger 82. When the sensor 10G is applied, the sensor cable 77 may be arranged along the non-tissue contacting surface 78 of the sensor body 80 by a healthcare worker. The alignment indices 76 provide an indication where the sensor cable 77 should lie against the sensor body 80 prior to being secured by bandages 81, as shown, or by tape or other securing mechanisms. Alternatively, the healthcare worker may wish to wrap the sensor cable 77 along the sensor body 80 in such a manner as to minimize the pressure of the sensor cable 77 against the patient's finger 82. In such an embodiment (not shown), the sensor cable 77 may be loosely wrapped such that the sensor cable 77 is not flush against the sensor body 80.

[0074] FIG. 8 illustrates a sensor 10J with an alternate sensor cable configuration. The sensor cable 114 is electrically connected to the emitter 110 and detector 112 by wire leads 113. The wire leads 113 join the sensor cable 114 within the sensor body 108, and the sensor cable 114 emerges from the sensor body 108 at an angle that is not in line with the plane of the sensor body 108 when the sensor body 108 is laid flat. Although the sensor body 108 generally assumes a more complex, nonplanar geometry after application to a patient's tissue, the result of this configuration is that the sensor cable 114 is directed away from the tissue. Thus, the sensor cable 114 may be less likely to interfere with patient motion or to compress the tissue. Such a configuration may be applied to the patient's tissue in any configuration. For example, the sensor 10J may be applied

such that the sensor cable 114 emerges from the sensor body 108 along the sides of the patient's finger. In such an embodiment, the sensor cable 114 emerges and is at an angle such that the sensor cable 114 is not flush against the tissue.

[0075] In another embodiment, it may be advantageous to replace all or part of a sensor cable with a lightweight flexible circuit. FIG. 9 illustrates an exemplary sensor 10I that includes a flexible circuit 82 electrically connecting the emitter 84 and the detector 86 to a sensor cable 88. The flexible circuit 82 includes conductive elements printed on a flexible, non-conductive substrate, such as polyimide or polyester, in order to provide electrical communication to and from the emitter 84 and the detector 86. The flexible circuit 82 may be embedded in the sensor body 90 in a region between the emitter 84 and the detector 86. As shown in FIG. 8, the flexible circuit 82 bends easily around the finger 83. As the flexible circuit 82 has few rigid surfaces, the tissue may experience fewer discoloration or deformation events associated with signal artifacts when pressed against the flexible circuit 82 embedded in the sensor body 90. The flexible circuit 82 may include at least one connection point that is suitable for electrically coupling the flexible circuit 82 to the sensor cable 88.

[0076] A sensor, illustrated generically as a sensor 10, may be used in conjunction with a pulse oximetry monitor 92, as illustrated in FIG. 10. It should be appreciated that the cable 94 of the sensor 10 may be coupled to the monitor 92 or it may be coupled to a transmission device (not shown) to facilitate wireless transmission between the sensor 10 and the monitor 92. The monitor 92 may be any suitable pulse oximeter, such as those available from Nellcor Puritan Bennett Inc. Furthermore, to upgrade conventional pulse oximetry provided by the monitor 92 to provide additional functions, the monitor 92 may be coupled to a multi-parameter patient monitor 96 via a cable 98 connected to a sensor input port or via a cable 100 connected to a digital communication port.

[0077] The sensor 10 includes an emitter 102 and a detector 104 that may be of any suitable type. For example, the emitter 102 may be one or more light emitting diodes adapted to transmit one or more wavelengths of light in the red to infrared range, and the detector 104 may be one or more photodetectors selected to receive light in the range or ranges emitted from the emitter 102. Alternatively, an emitter may also be a laser diode or a vertical cavity surface emitting laser (VCSEL). An emitter and detector may also include optical fiber sensing elements. An emitter may include a broadband or "white light" source, in which case the detector could include any of a variety of elements for selecting specific wavelengths, such as reflective or refractive elements or interferometers. These kinds of emitters and/or detectors would typically be coupled to the rigid or rigidified sensor via fiber optics. Alternatively, a sensor may sense light detected from the tissue is at a different wavelength from the light emitted into the tissue. Such sensors may be adapted to sense fluorescence, phosphorescence, Raman scattering, Rayleigh scattering and multi-photon events or photoacoustic effects. For pulse oximetry applications using either transmission or reflectance type sensors the oxygen saturation of the patient's arterial blood may be determined using two or more wavelengths of light, most commonly red and near infrared wavelengths. Similarly, in other applications, a tissue water fraction (or other body fluid related metric) or a concentration of one or more

biochemical components in an aqueous environment may be measured using two or more wavelengths of light, most commonly near infrared wavelengths between about 1,000 nm to about 2,500 nm. It should be understood that, as used herein, the term “light” may refer to one or more of ultrasound, radio, microwave, millimeter wave, infrared, visible, ultraviolet, gamma ray or X-ray electromagnetic radiation, and may also include any wavelength within the radio, microwave, infrared, visible, ultraviolet, or X-ray spectra.

[0078] The emitter **102** and the detector **104** may be disposed on a sensor body **106**, which may be made of any suitable material, such as plastic, foam, woven material, or paper, and may include elastic portions. Alternatively, the emitter **102** and the detector **104** may be remotely located and optically coupled to the sensor **10** using optical fibers. In the depicted embodiments, the sensor **10** is coupled to a cable **94** that is responsible for transmitting electrical and/or optical signals to and from the emitter **102** and detector **104** of the sensor **10**. The cable **94** may be permanently coupled to the sensor **10**, or it may be removably coupled to the sensor **10**—the latter alternative being more useful and cost efficient in situations where the sensor **10** is disposable.

[0079] The sensor **10** may be a “transmission type” sensor. Transmission type sensors include an emitter **102** and detector **104** that are typically placed on opposing sides of the sensor site. If the sensor site is a fingertip, for example, the sensor **10** is positioned over the patient’s fingertip such that the emitter **102** and detector **104** lie on either side of the patient’s nail bed. In other words, the sensor **10** is positioned so that the emitter **102** is located on the patient’s fingernail and the detector **104** is located 180° opposite the emitter **102** on the patient’s finger pad. During operation, the emitter **102** shines one or more wavelengths of light through the patient’s fingertip and the light received by the detector **104** is processed to determine various physiological characteristics of the patient. In each of the embodiments discussed herein, it should be understood that the locations of the emitter **102** and the detector **104** may be exchanged. For example, the detector **104** may be located at the top of the finger and the emitter **102** may be located underneath the finger. In either arrangement, the sensor **10** will perform in substantially the same manner.

[0080] Reflectance type sensors also operate by emitting light into the tissue and detecting the light that is transmitted and scattered by the tissue. However, reflectance type sensors include an emitter **102** and detector **104** that are typically placed on the same side of the sensor site. For example, a reflectance type sensor may be placed on a patient’s finger or forehead such that the emitter **102** and detector **104** lie side-by-side. Reflectance type sensors detect light photons that are scattered back to the detector **152**. A sensor **10** may also be a “transflectance” sensor, such as a sensor that may subtend a portion of a patient’s heel.

[0081] While the invention may be susceptible to various modifications and alternative forms, specific embodiments have been shown by way of example in the drawings and have been described in detail herein. However, it should be understood that the invention is not intended to be limited to the particular forms disclosed. Indeed, the present techniques may not only be applied to measurements of blood oxygen saturation, but these techniques may also be utilized for the measurement and/or analysis of other blood and/or tissue constituents using principles of pulse oximetry. For

example, using the same, different, or additional wavelengths, the present techniques may be utilized for the measurement and/or analysis of carboxyhemoglobin, methemoglobin, total hemoglobin, fractional hemoglobin, intravascular dyes, hematocrit, carbon dioxide, carbon monoxide, protein, lipid and/or water content or compartmentalization. Rather, the invention is to cover all modifications, equivalents, and alternatives falling within the spirit and scope of the invention as defined by the following appended claims.

What is claimed is:

1. A sensor comprising:

a sensor body;

at least one sensing element disposed on the sensor body;

and

a cable adapted to be electrically coupled to the sensing element, wherein the cable is disposed along the sensor body in a curvilinear configuration.

2. The sensor, as set forth in claim 1, wherein the sensor comprises at least one of a pulse oximetry sensor or a sensor for measuring a water fraction.

3. The sensor, as set forth in claim 1, wherein the sensor comprises a cable guide adapted to hold the cable in the curvilinear configuration.

4. The sensor, as set forth in claim 1, wherein the cable is embedded in the sensor body in a curvilinear configuration.

5. The sensor, as set forth in claim 1, wherein the cable emerges from the sensor body at a site not on the outer perimeter of the sensor body.

6. The sensor, as set forth in claim 1, wherein the cable emerges from the sensor body at an angle not in line with the plane of the sensor body.

7. The sensor, as set forth in claim 1, wherein the sensor comprises a reflectance-type sensor.

8. The sensor, as set forth in claim 1, wherein the sensor comprises a transmission-type sensor.

9. A system comprising:

a monitor; and

a sensor adapted to be operatively coupled to the monitor,

the

sensor comprising:

a sensor body;

at least one sensing element disposed on the sensor body; and

a cable adapted to be electrically coupled to the sensing element, wherein the cable is disposed along the sensor body in a curvilinear configuration.

10. The system, as set forth in claim 9, wherein the sensor comprises at least one of a pulse oximetry sensor or a sensor for measuring a water fraction.

11. The system, as set forth in claim 9, wherein the sensor comprises a cable guide adapted to hold the cable in the curvilinear configuration.

12. The system, as set forth in claim 9, wherein the cable is embedded in the sensor body in a curvilinear configuration.

13. The system, as set forth in claim 9, wherein the cable emerges from the sensor body at a site not on the outer perimeter of the sensor body.

14. The sensor, as set forth in claim 9, wherein the cable emerges from the sensor body at an angle not in line with the plane of the sensor body.

15. The system, as set forth in claim 9, wherein the sensor comprises a reflectance-type sensor.

16. The system, as set forth in claim 9, wherein the sensor comprises a transmission-type sensor.

17. A method comprising:

electrically coupling a sensing element to a monitor with a cable, wherein sensing element is disposed on the sensor body and wherein the cable is disposed along the sensor body in a curvilinear configuration.

18. The method, as set forth in claim 17, wherein the sensor comprises a cable guide adapted to hold the cable in the curvilinear configuration.

19. The method, as set forth in claim 17, wherein the cable is embedded in the sensor body in a curvilinear configuration.

20. A method of manufacturing a sensor, comprising:
providing a sensor body;
providing at least one sensing element disposed on the sensor body; and

providing a cable adapted to be electrically coupled to the sensing element, wherein the cable is disposed along the sensor body in a curvilinear configuration.

21. The method, as set forth in claim 20, wherein the sensor comprises a cable guide adapted to hold the cable in the curvilinear configuration.

22. The method, as set forth in claim 20, wherein the cable is embedded in the sensor body in a curvilinear configuration.

23. The method, as set forth in claim 20, wherein the cable emerges from the sensor body at a site not on the outer perimeter of the sensor body.

24. The method, as set forth in claim 20, wherein the cable emerges from the sensor body at an angle not in line with the plane of the sensor body.

* * * * *

专利名称(译)	用于减少信号伪影的医疗传感器及其使用技术		
公开(公告)号	US20080076980A1	公开(公告)日	2008-03-27
申请号	US11/525396	申请日	2006-09-22
[标]申请(专利权)人(译)	内尔科尔普里坦贝内特公司		
申请(专利权)人(译)	NELLCOR PURITAN BENNETT INCORPORATED		
当前申请(专利权)人(译)	COVIDIEN LP		
[标]发明人	HOARAU CARINE		
发明人	HOARAU, CARINE		
IPC分类号	A61B5/00		
CPC分类号	A61B5/14552 A61B5/6826 A61B2562/164 A61B5/7207 A61B5/6838		
优先权	11/525635 2006-09-22 US 11/525636 2006-09-22 US 11/525693 2006-09-22 US 11/525704 2006-09-22 US		
其他公开文献	US8190224		
外部链接	Espacenet USPTO		

摘要(译)

传感器可以适于通过减轻在传感器内移动的组织的影响来减少运动伪影。传感器设有适于容纳患者运动的弹性体传感器主体。此外，提供了一种传感器，其中传感器电缆布置成减轻其对患者组织的压力。

