



US 20060116561A1

(19) **United States**

(12) **Patent Application Publication**
Tricca et al.

(10) **Pub. No.: US 2006/0116561 A1**
(43) **Pub. Date: Jun. 1, 2006**

(54) **SYSTEMS AND METHODS FOR
INTRA-ORAL DIAGNOSIS**

(21) Appl. No.: **11/000,433**

(22) Filed: **Nov. 30, 2004**

(76) Inventors: **Robert E. Tricca**, Danville, CA (US);
Benjamin M. Wu, Los Angeles, CA
(US); **Chunhua Li**, Cupertino, CA
(US); **Eric Kuo**, Foster City, CA (US)

Publication Classification

(51) **Int. Cl.**
A61B 5/00 (2006.01)

(52) **U.S. Cl.** **600/309**

(57) **ABSTRACT**

Systems and methods are disclosed for detecting or diagnosing diseases by sampling and testing intra-oral fluids.

Correspondence Address:
ALIGN TECHNOLOGY, INC.
ATTENTION: SCOTT SMITH
881 MARTIN AVENUE
SANTA CLARA, CA 95050 (US)

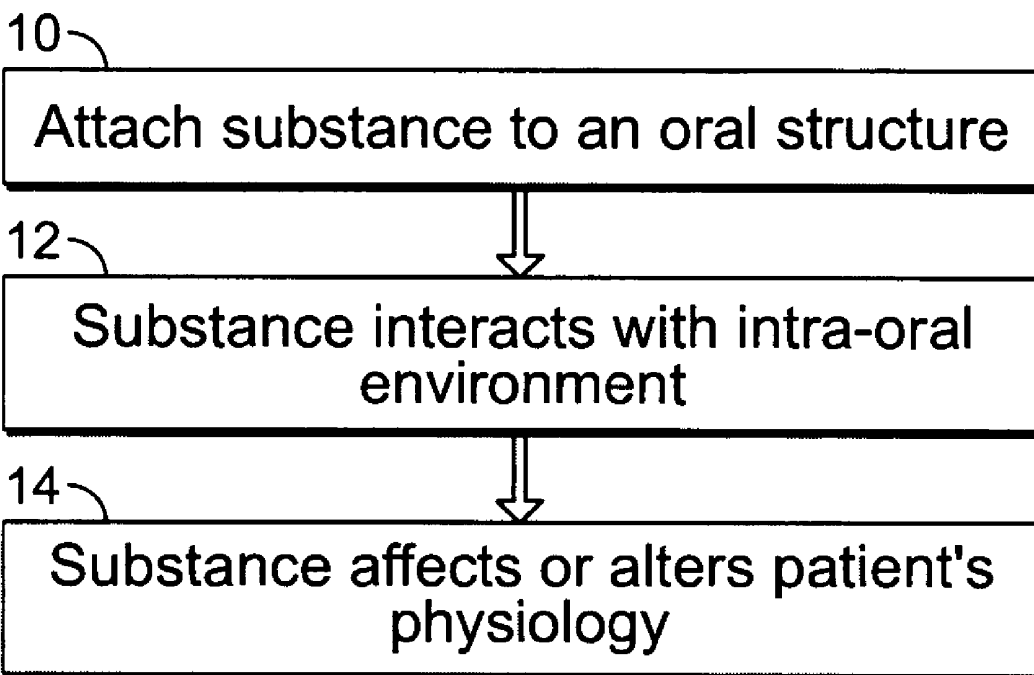

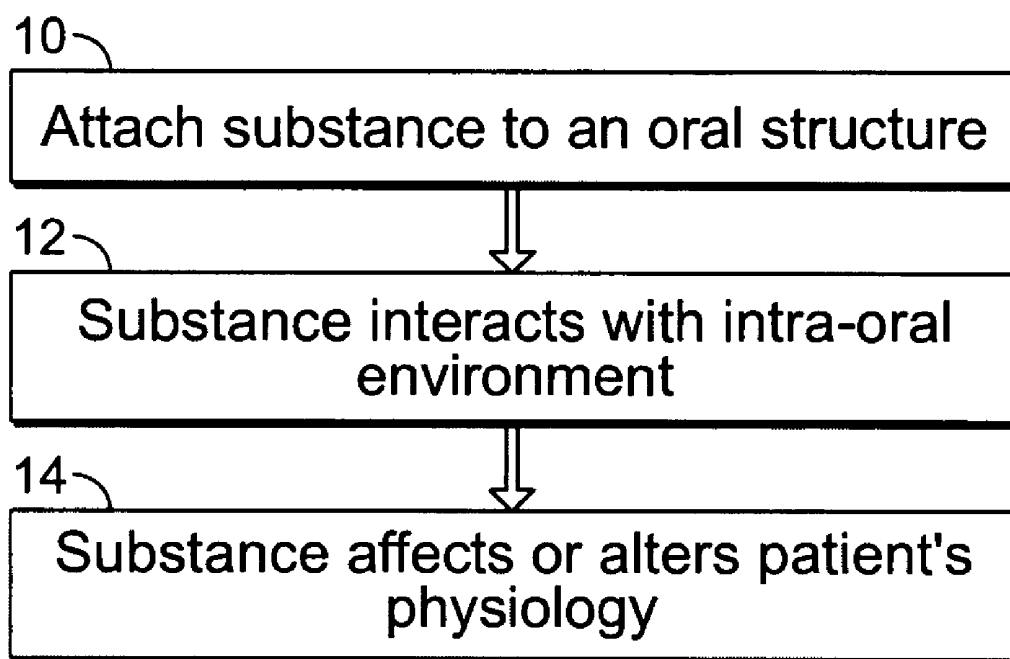

FIG. 1

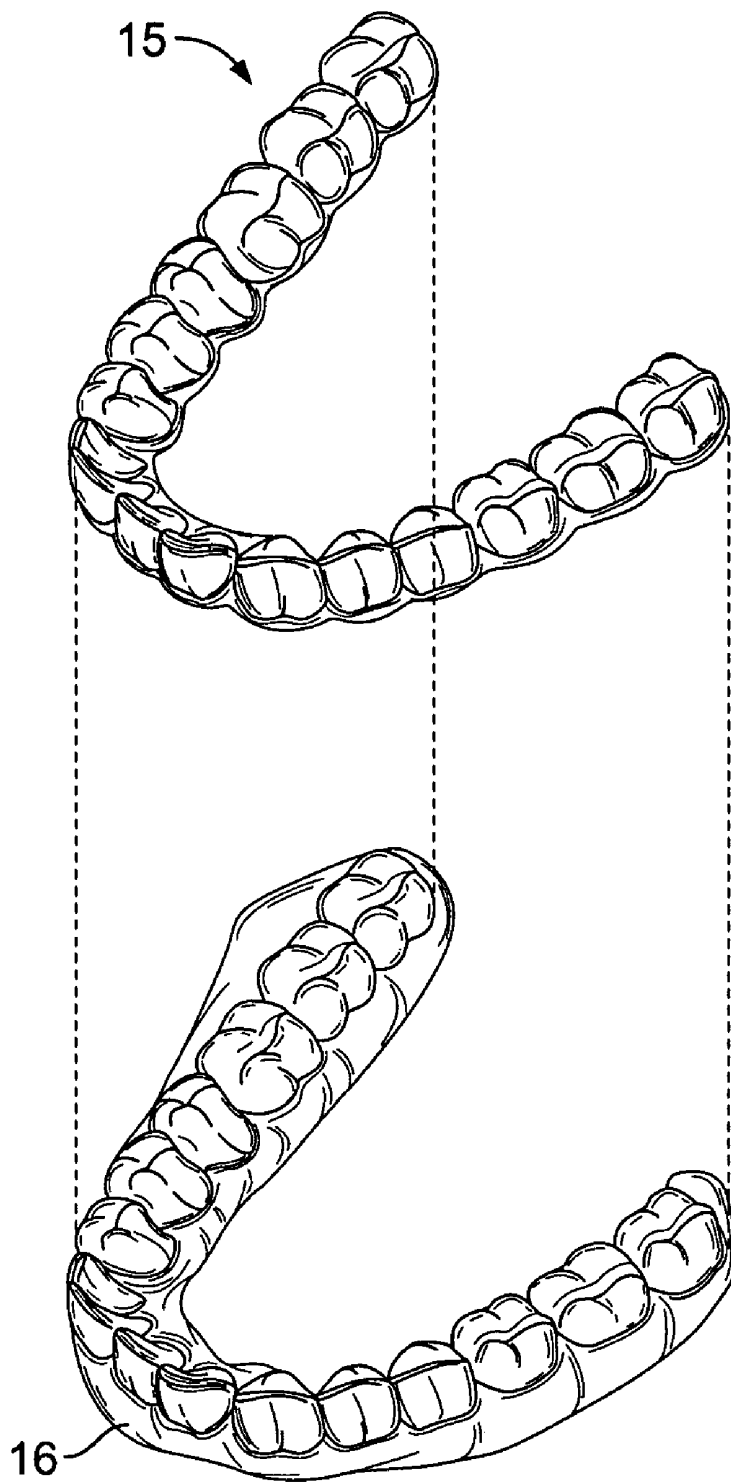

FIG. 2A

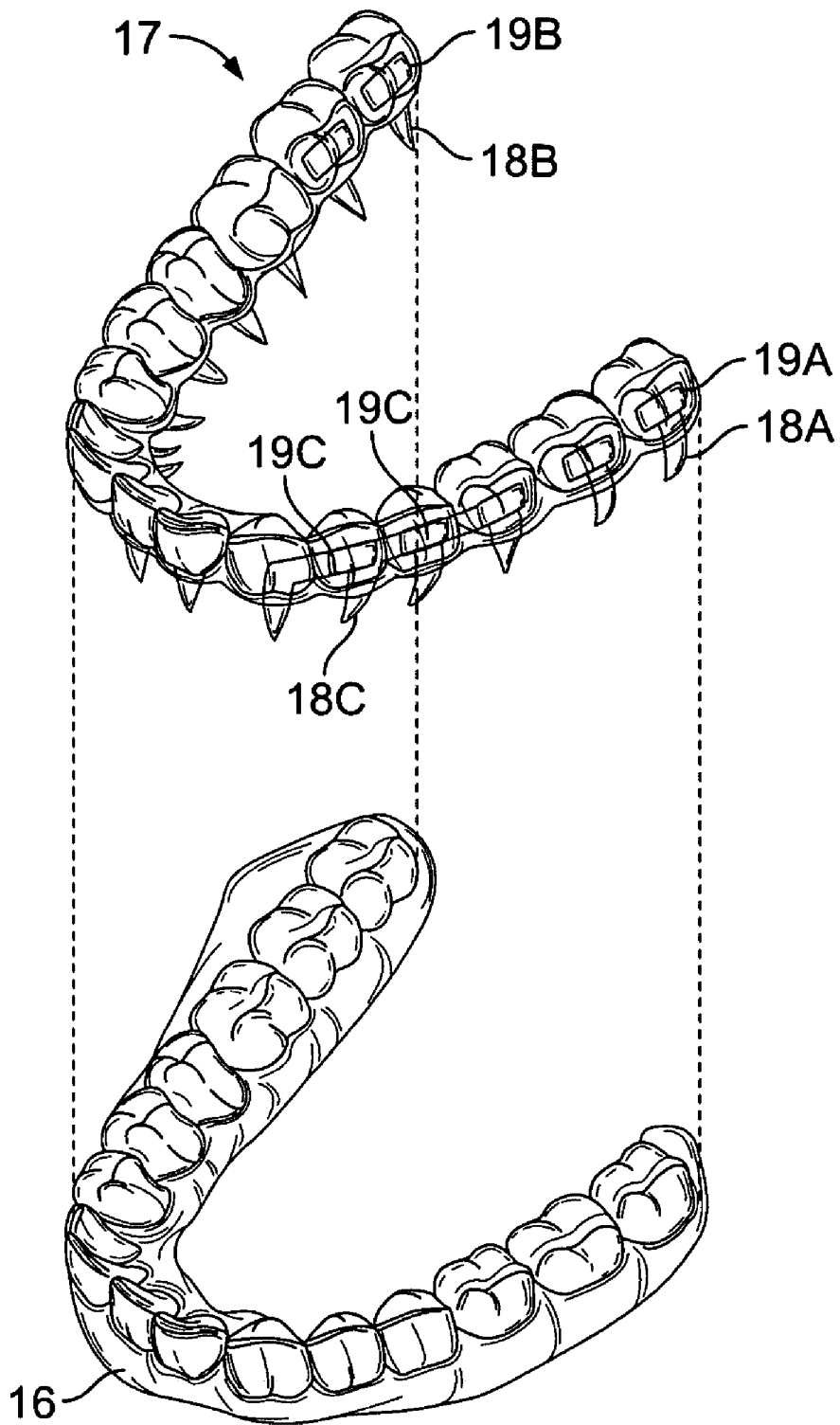

FIG. 2B

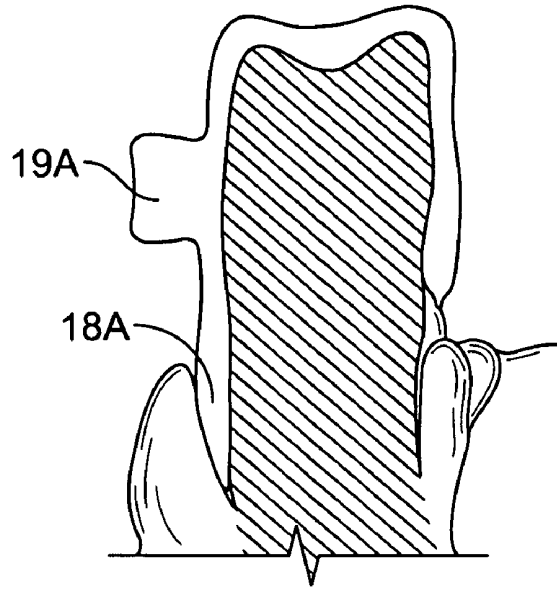

FIG. 2C

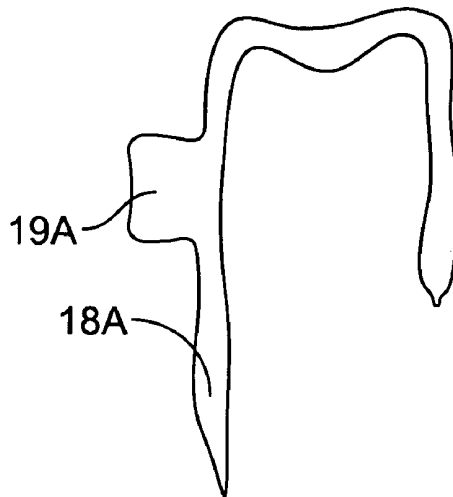

FIG. 2D

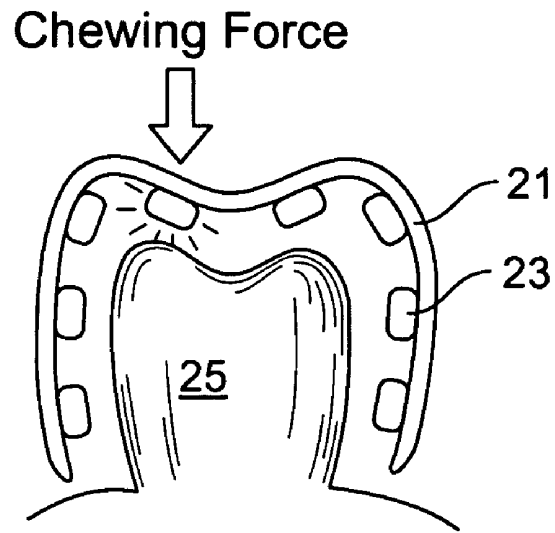

FIG. 2E

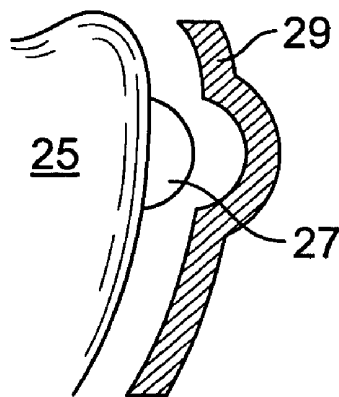

FIG. 2F

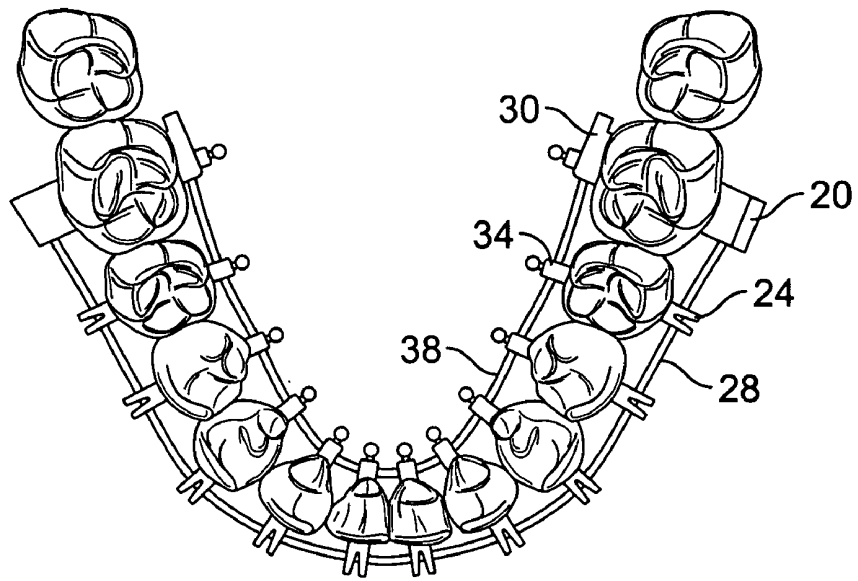

FIG. 3

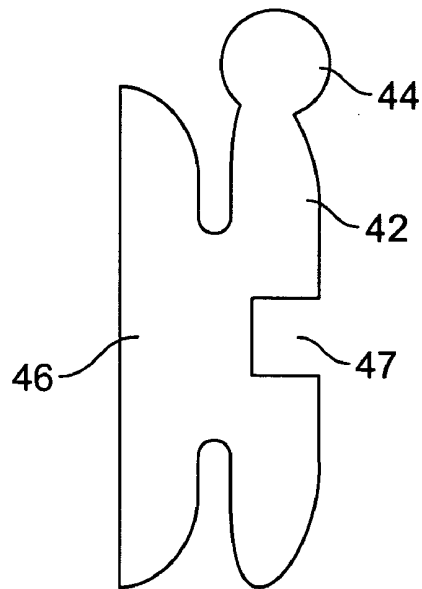

FIG. 4A

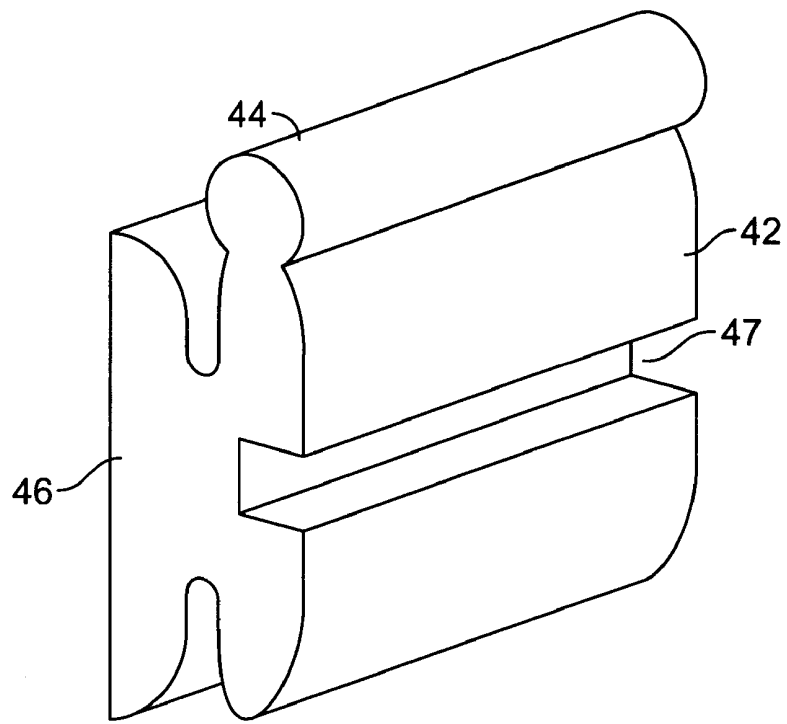

FIG. 4B

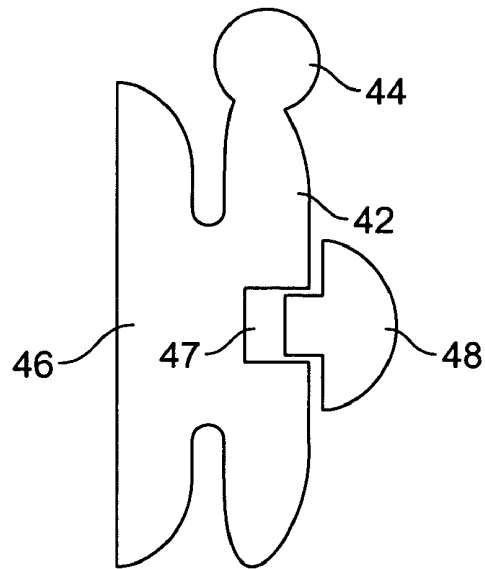

FIG. 4C

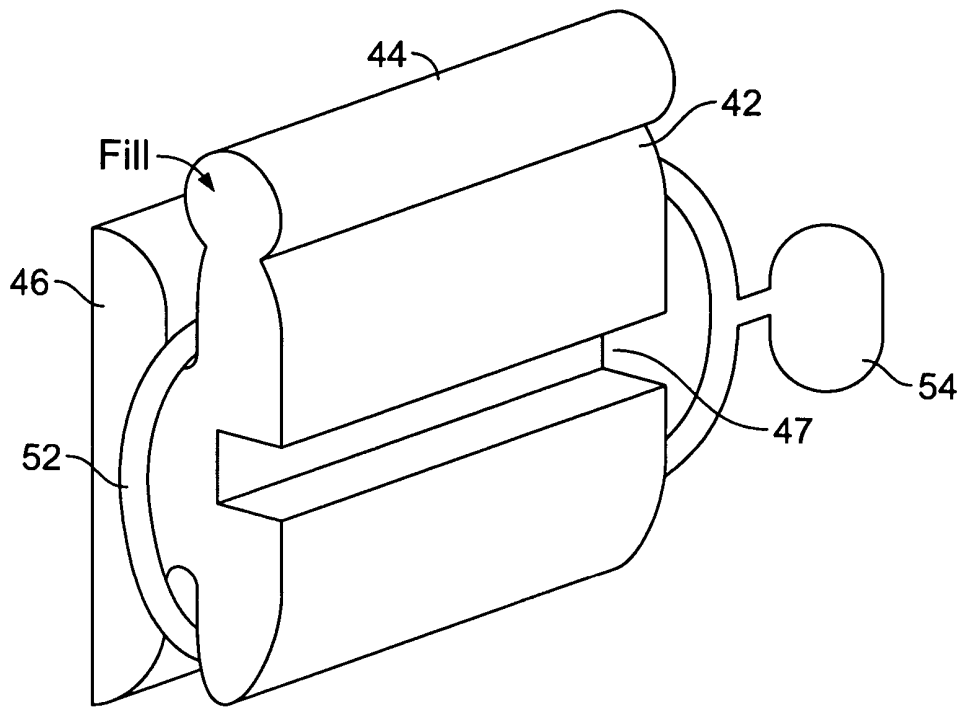

FIG. 4D

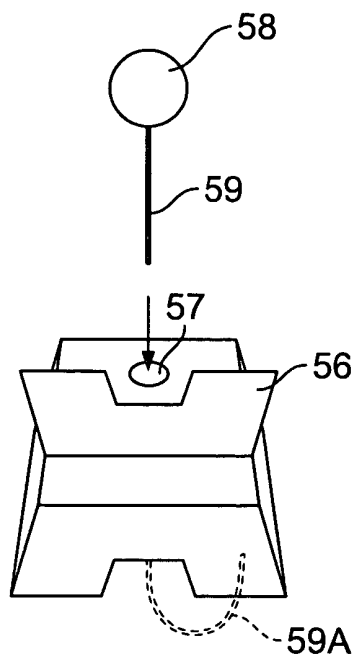

FIG. 4E

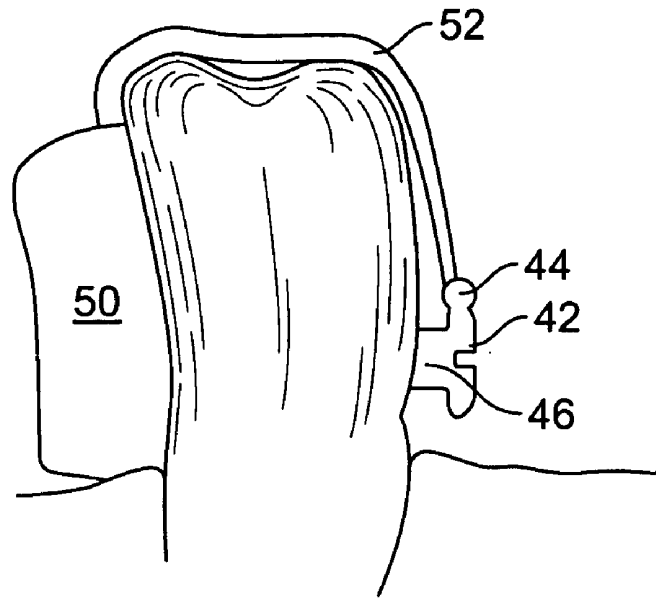

FIG. 5A

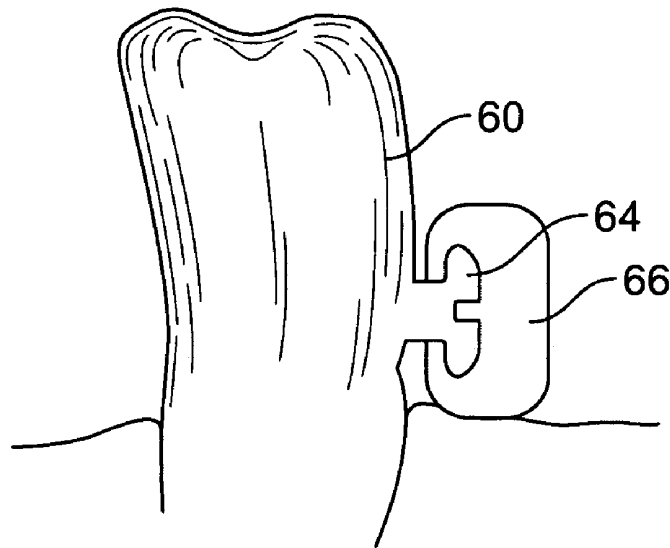

FIG. 5B

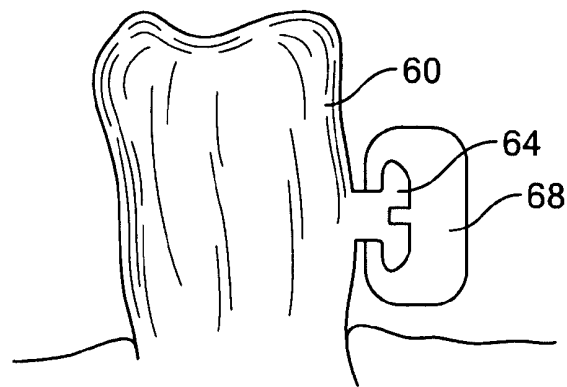

FIG. 5C

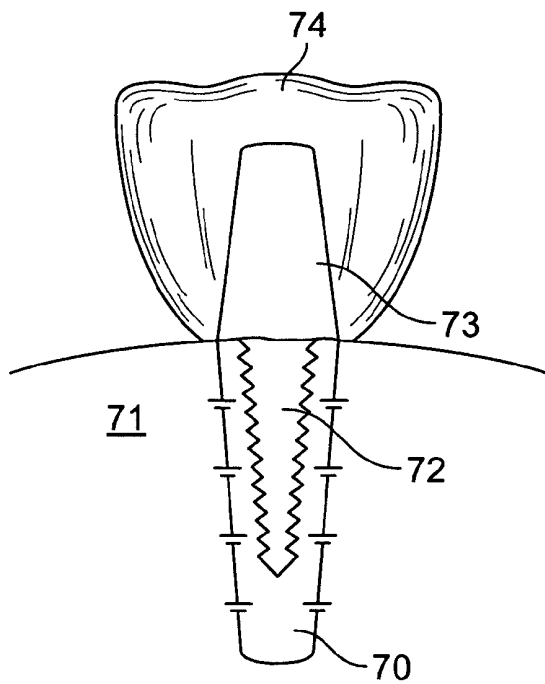

FIG. 5D

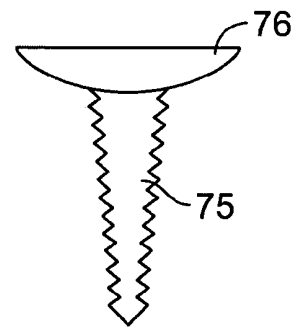

FIG. 5E

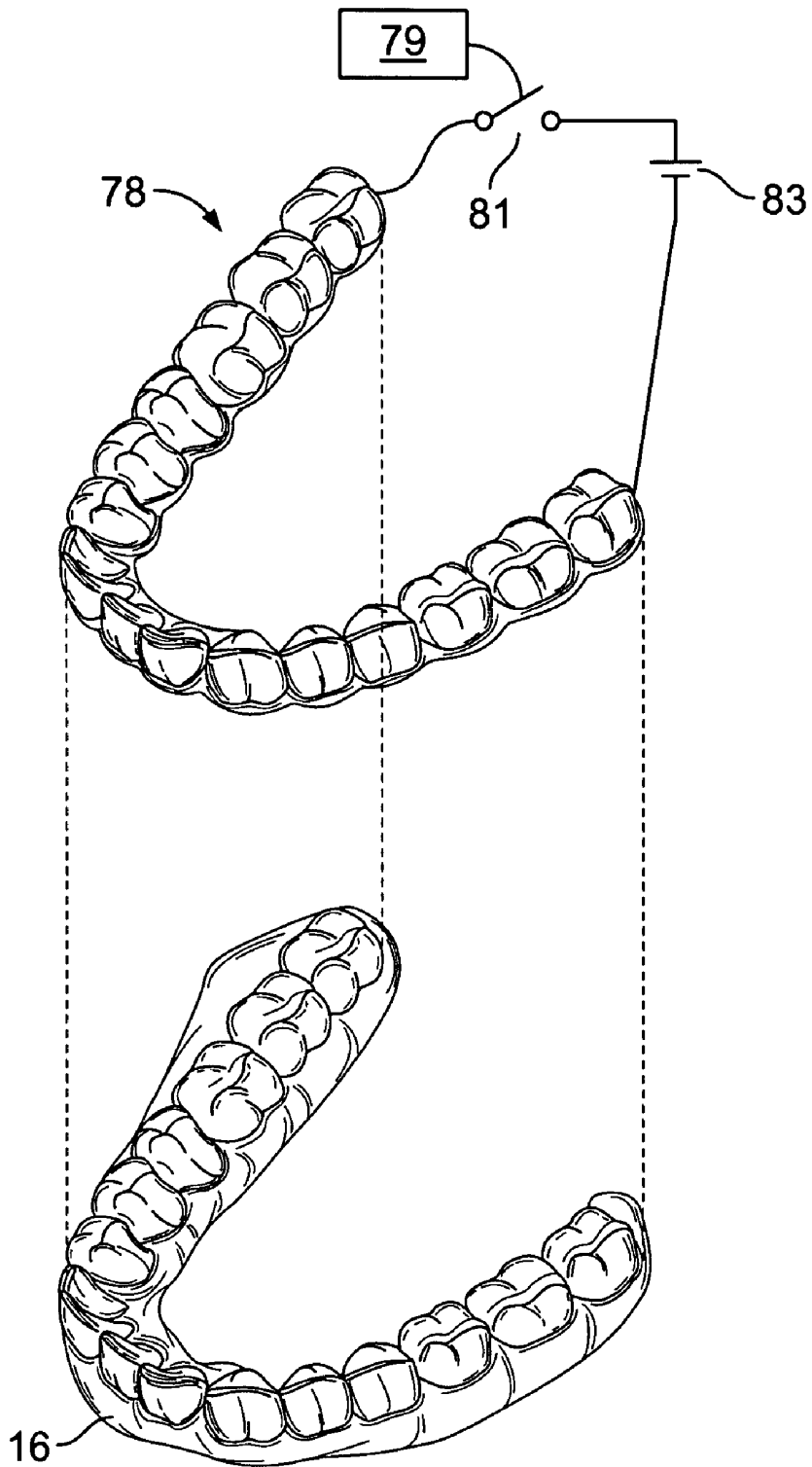

FIG. 6A

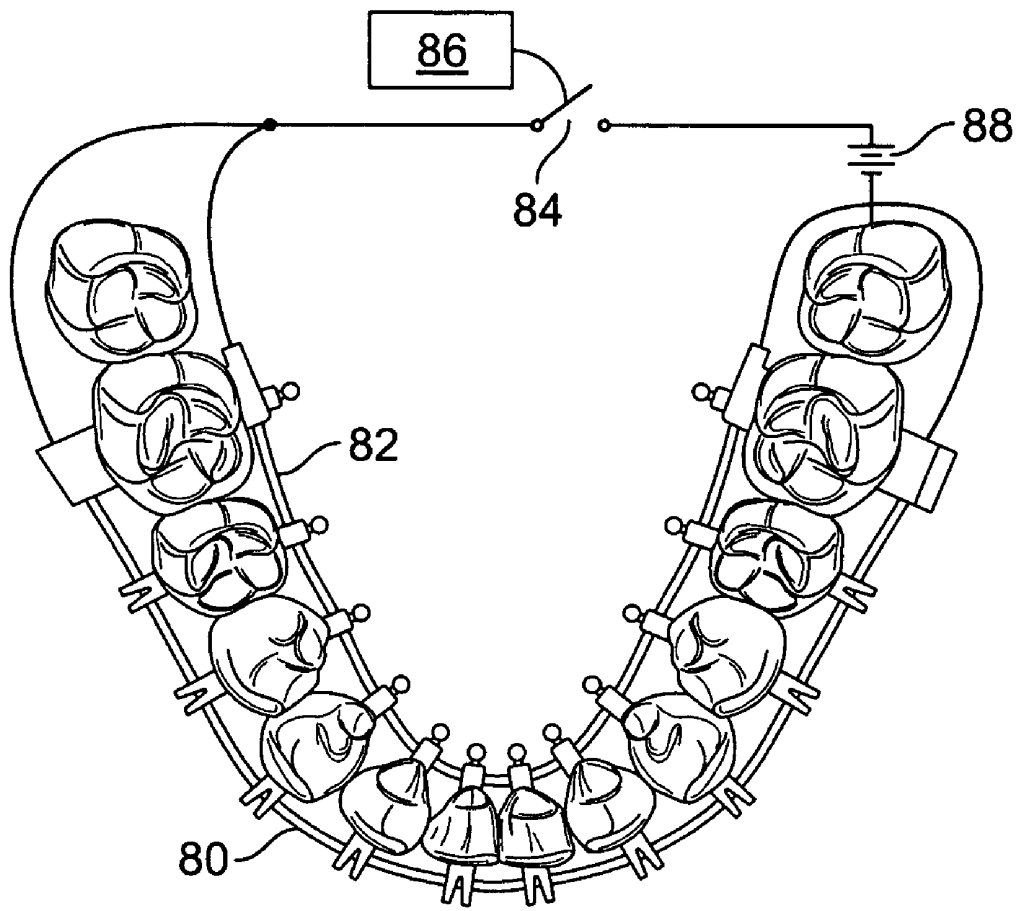

FIG. 6B

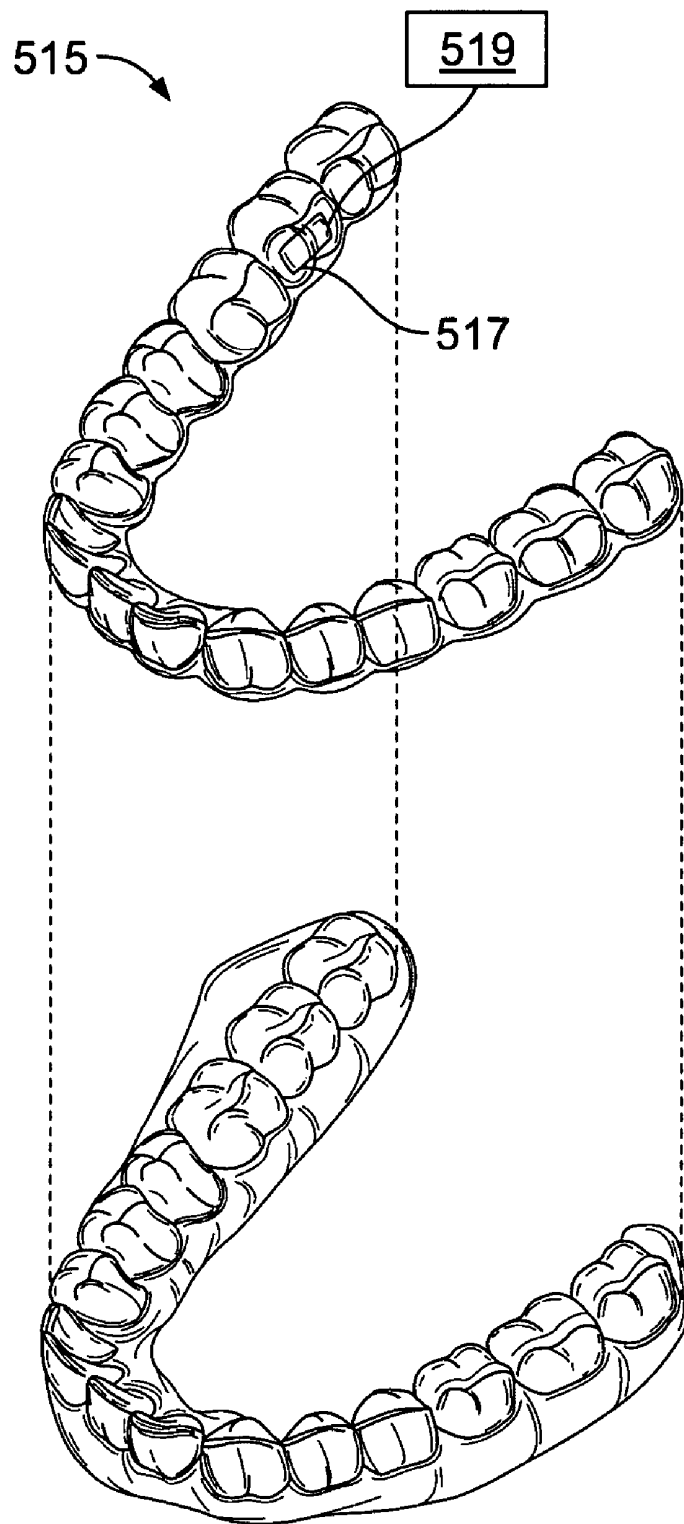

FIG. 7A

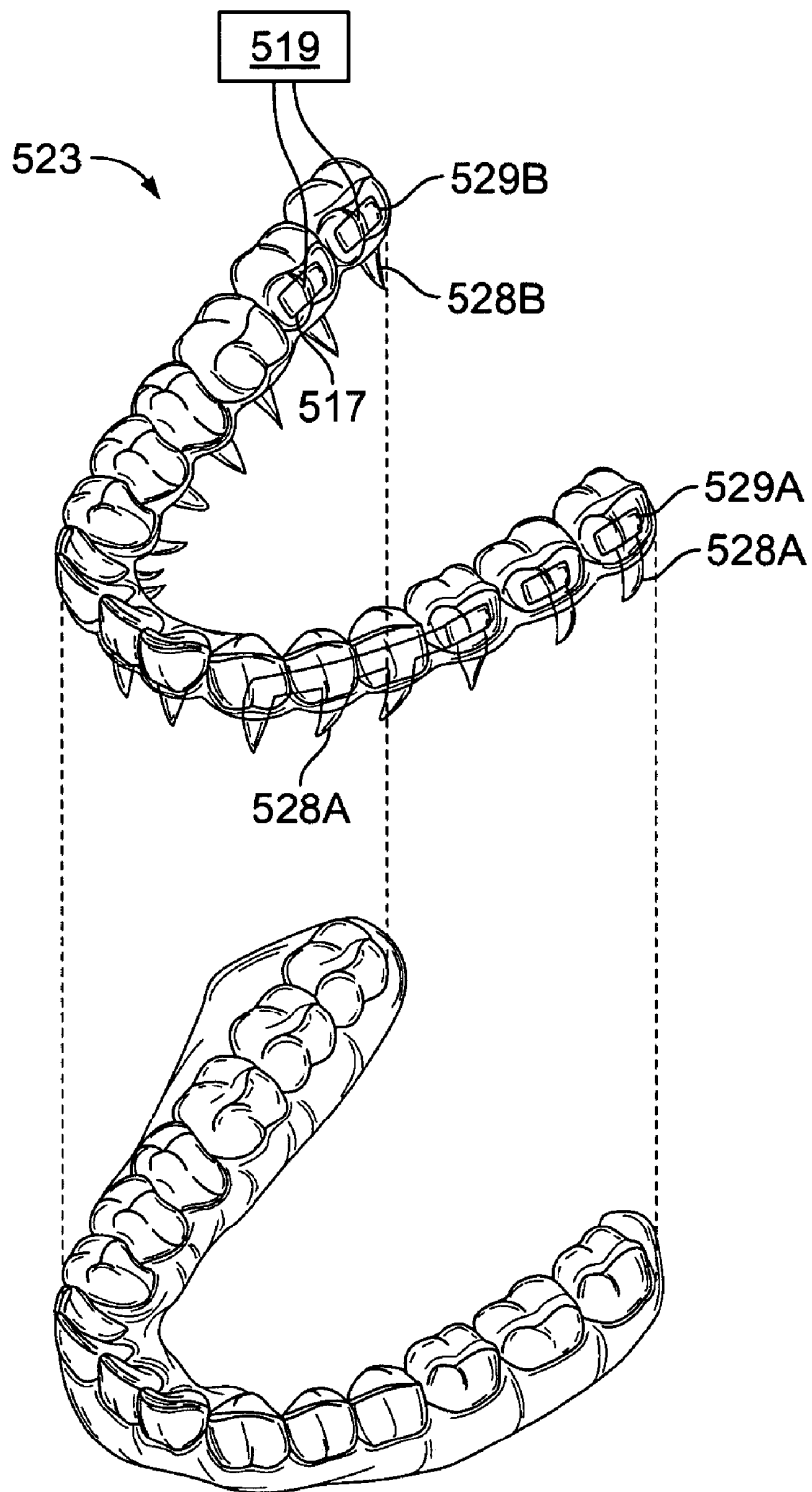

FIG. 7B

SYSTEMS AND METHODS FOR INTRA-ORAL DIAGNOSIS

BACKGROUND

[0001] The present invention is related to systems and methods for intra-oral diagnosis.

[0002] As noted in commonly owned U.S. Pat. No. 6,607,382 entitled "Methods and systems for concurrent tooth repositioning and substance delivery," the content of which is incorporated herewith, the repositioning of teeth may be accomplished with the use of a series of removable elastic positioning appliances such as the Invisalign® system available from Align Technology, Inc., the assignee of the present invention. Such appliances have a thin shell of elastic material that generally conforms to a patient's teeth but is slightly out of alignment with an initial or immediately prior tooth configuration. Placement of the elastic positioner over the teeth applies controlled forces in specific locations to gradually move the teeth into the new configuration. Repetition of this process with successive appliances comprising new configurations eventually moves the teeth through a series of intermediate configurations or alignment patterns to a final desired configuration. A full description of an exemplary elastic polymeric positioning appliance is described in U.S. Pat. No. 5,975,893, and in published PCT application WO 98/58596, the content of these documents are incorporated by reference for all purposes.

[0003] The appliance is effective in repositioning teeth when it is placed over the patient's teeth. Removal of the appliance for any reason interrupts the treatment plan and lengthens the overall period of treatment. Therefore, removal of the appliance should be minimized for effective and timely treatment. However, a number of dental and periodontal therapies which may be desired or required by the patient may not be effectively utilized while the appliance is in place. Such therapies may be prescribed by a practitioner to improve oral health or they may be requested by the patient for cosmetic purposes.

[0004] The '382 patent discloses devices, systems and methods for orthodontic treatment using elastic repositioning appliances while concurrently providing dental and periodontal therapies. Such therapies are traditionally provided with the use of a variety of accessories and devices which are applied when the repositioning appliance is removed from the patient's mouth. The '382 system eliminates the need for such removal and additional devices by incorporating these therapies into the repositioning appliance.

[0005] United States Patent Application 20040115587, the content of which is incorporated herewith, discloses an orthodontic treatment involving applying force to reposition teeth and administering a tissue remodeling and/or an angiogenic substance(s) to the periodontal tissue surrounding the teeth to be moved. The substance(s) may be delivered before, during, or after the teeth are moved, and the substance(s) may be selectively applied only to those teeth undergoing movement at any particular time. The substance(s) may be applied from the dental repositioning appliance or may be applied separately, either topically or by injection.

BRIEF DESCRIPTION OF THE DRAWINGS

[0006] FIG. 1 shows an exemplary method for intra-oral delivery of a substance to an individual.

[0007] FIGS. 2A-2B are exemplary removable appliances adapted to fit over teeth on a jaw.

[0008] FIG. 2C shows a cross-sectional view of the appliance of FIG. 2B on an exemplary tooth.

[0009] FIG. 2D is a cross sectional view of FIG. 2C without the tooth and gum line.

[0010] FIGS. 2E-2F show additional embodiments of appliances for delivery of drugs or agents.

[0011] FIG. 3 illustrates another drug delivery system.

[0012] FIGS. 4A-4E illustrate various views of a bracket with a reservoir.

[0013] FIGS. 5A-5E show various embodiments of drug delivery systems.

[0014] FIG. 6A illustrates an embodiment where energy is applied to an appliance to effect teeth movement or drug delivery.

[0015] FIG. 6B illustrates an embodiment where energy is applied to wires to effect teeth movement or drug delivery.

[0016] FIG. 7A shows an embodiment of a diagnostic appliance.

[0017] FIG. 7B shows an embodiment of a diagnostic appliance that also intra-orally delivers drug or compound.

SUMMARY

[0018] Systems and methods are disclosed for detecting or diagnosing diseases by sampling and testing intra-oral fluids.

[0019] Advantages of the system include one or more of the following. The system can be deployed as sensors for systemic diseases, such as diabetes, arthritis, osteoporosis, HIV, cardiovascular disease (heart disease, stroke, high blood pressure), osteoporosis, obesity, blindness, kidney disease, and nervous system diseases.

Description

Appliance for Drug Delivery

[0020] FIG. 1 shows an exemplary method for intra-oral delivery of a substance to an individual such as a patient, for example. The substance can be a drug or a bio-active agent, among others. The process of FIG. 1 includes attaching the substance to an oral structure (10) and allowing the substance to intra-orally interact with the body of the individual (12). In one embodiment, the substance is fluidly provided from the oral structure into the body at a predetermined rate. The substance eventually affects or alters the individual's physiology in a desired manner (14). The term "oral structure" refers to all areas within the mouth, including teeth, gingiva, cheeks, gums, lips, tongue, thorax, back of the throat, and beneath the tongue.

[0021] The method of FIG. 1 thus attaches the substance to an oral structure using a suitable dental device; and fluidly providing the substance from the oral structure into a body at a pre-selected dose. The substance can accelerate or decelerate tooth movement.

[0022] The substance can induce irritation of the oral structure or can induce inflammation of a bone structure. The pattern or sequence of irritation or inflammation can be

varied. For example, the pressure, timing, location, degree of irritation or inflammation, and the depth of the irritation or inflammation can be varied.

[0023] The substance can be positioned on a bracket, a dental attachment, a bracket auxiliary, a ligature tie, a pin, a bracket slot cap, a wire, a screw, a micro-staple, a denture, a partial denture, a dental implant, a periodontal probe, a periodontal chip, a film, or a space between teeth. The substance can also be positioned on a removable appliance, and one or more modules may be positioned on the removable appliance to house the substance. The substance can provide energy for treatment, for example electric, light, heat, sound, magnetic or electromagnetic energy. The oral structure can be recharged with an additional amount of the same or different substance.

[0024] In one embodiment, the physical volume or shape of the substance is computer designed to support a precise delivery of the substance. A computer system can scan a patient's dentition; and design one or more appliances to attach the substance to the oral structure based on the scanned dentition. At least one of the appliances is designed to dispense the preselected dose. Moreover, the appliances can dispense the substance in a predetermined sequence. For example, at least two of the appliances can dispense the substance in two different dosages for delivery at two different periods. Thus, for birth control drugs, more can be delivered on day 15 and less can be delivered on day 30, for example.

[0025] The system can perform diagnostics as well. To do this, the system samples an intra-oral substance; and detects a body condition (such as a disease) based on the intra-oral substance. A processor can receive the sampling result and performs a close-loop delivery of substance based on a sampled intra-oral substance, as discussed in more detail below. The system can also transmit the detected body condition to a remote computer for diagnosis.

[0026] The substance can be any known chemical substance. Preferably, the substance is a medical grade drug, chemical agent, or a bioactive agent. Examples of the drug or agent can include antibacterials, antibiotics, anti-inflammatory agents, immune-suppressive agents, immune-stimulatory agents, dentinal desensitizers, odor masking agents, immune reagents, anesthetics, nutritional agents, antioxidants, lipopolysaccharide complexing agents, and peroxides, among others.

[0027] The attachment of the substance to the oral structure can be done through a removable appliance, a fixed appliance such as a bracket, a dental attachment, a wire, a screw, a tap, a micro-staple, a dental implant, a perioprobe, a periochip, a film or composite material, or a space between teeth, among others.

[0028] The tooth is held firmly in place by the cementum, periodontal ligament, alveolar bone and gingiva. These connective tissue structures contain collagen and elastin fibers crosslinked into a supporting matrix. Additional components of this matrix include glycosaminoglycans (GAGs) and proteoglycans which play a role in resisting compressive forces in tissues. The architecture of this matrix can shift over time in response to a constant pressure that stimulates matrix breakdown, matrix resynthesis and remodeling of the tissue. To accelerate tooth movement, agents increase the rate of matrix degradation during the period in which force is applied to the tooth.

[0029] FIG. 2A shows an exemplary removable appliance 15 adapted to fit over teeth on a jaw 16. The appliance can be coated with a drug, chemical agent, or a bioactive agent. In one embodiment, the drug is inactive until contact with water or saliva. Alternatively, release of the agent can be stimulated by water or by saliva. Thus, in one case, upon wearing, saliva activates the drug/agent and allows the drug/agent to seep out and treat the patient through the oral cavity of the patient. The substance can also be delivered through the patient's gingiva.

[0030] The appliance can release the agent to the oral environment when the appliance is placed over the teeth. Such means may comprise a layer which includes the agent. The layer may be formed over at least a portion of the surfaces of the repositioning appliance. These surfaces include both the cavity surfaces, the surfaces within the cavities which contact the teeth when in place, and the external surfaces, the surfaces of the appliance which contact the cheeks and lips when in place. The layer may be comprised of various materials and may take a variety of forms. For example, the layer may consist essentially of the agent. In other words, the agent may be attached directly to a surface of the polymer shell of an elastic repositioning appliance. This may be achieved by applying the agent (optionally in an inert carrier or diluent) itself to the surface utilizing a number of methods, such as spraying, painting and/or dipping. When the repositioning appliance is placed over the patient's teeth, the agent may then be released to the oral environment.

[0031] Alternatively, the layer may comprise the agent present in or on a carrier or binder which promotes adhesion or attachment to the appliance and/or which creates a matrix from which the agent can be released by diffusion or dissolution. In one embodiment, the agent is dissolved in the carrier or binder. In this case, the agent may be provided in powder or similar form and dissolved in a liquid solvent. The result may be a solution which may be applied to a surface of the shell, typically by spraying, painting and/or dipping, to form a coating or film. When the repositioning appliance is placed over the patient's teeth, the agent may then be released from the coating to the oral environment. Release may be due to activation or deactivation of the carrier or any other releasing mechanism, such as by enzymes or proteins in saliva. Or release may be due to degradation of the carrier by contact with, for example, saliva. In some cases, the binder or carrier may evaporate upon application to the layer to the surface leaving the agent behind. In these cases, the agent may be released in a similar fashion as when the agent is directly attached to the surface, as described above. It may be appreciated that any agent, particularly fluoride materials, antibiotics, bleaching materials and breath fresheners, may be delivered to the oral environment in this manner.

[0032] In another embodiment, the agent is encapsulated or suspended in the layer. A common material for suspension of an agent is a semisolid material, such as a gel, jelly or putty. Such a material may be applied to a surface of the shell by spraying, painting and/or dipping to form a coating or film. Here, as in all cases, suspension is not limited to a scientific definition and may refer to any situation in which a carrier holds, contains, supports or otherwise includes an agent. Alternatively or in addition, the semisolid material may be deposited in the cavities of the polymer shell which are shaped to receive the teeth. The cavities may be filled to

any desired level. When the repositioning appliance is positioned over the teeth, the teeth will directly contact the semisolid material in the cavities and displace any extra material as the teeth are inserted into the cavities. Therefore, it is desired to fill the cavities to a level which will avoid excess overflow of the material from the appliance. Delivery of an agent by use of a semisolid suspension material is common in bleaching treatments and fluoride treatments, for example. However, such treatments apply the material with the use of a tray or generic appliance which does not apply repositioning forces to the teeth. By modifying a repositioning appliance, as described above, orthodontic treatment may continue throughout the delivery of such agents. It may be appreciated that any agent, particularly fluoride materials, antibiotics, bleaching materials and breath fresheners, may be delivered to the oral environment in this manner.

[0033] Another common material for encapsulation or suspension of an agent is a controlled-release material. Thus, the layer may be comprised of a rate-controlling material wherein the rate controlling material controls the rate at which the agent is released from the layer. Controlled-release or rate-controlled materials deliver a predetermined amount of an agent at a predetermined rate. Often such delivery maintains a steady-state concentration of an agent in an environment within a desired therapeutic range for a prolonged period of time. Thus, a prescribed dosage may be delivered. In addition, the ability to sustain delivery eliminates the need for repeated applications of the agent for dosed delivery to the oral environment.

[0034] Although such controlled release materials may be provided as a semisolid material, such as a gel, jelly or putty, as described above, these materials may also be provided as a solid material which is attached to the polymeric shell of the repositioning appliance. One type of controlled-release material comprises a polymer matrix membrane within which finely dispersed particles of an agent are suspended. The agent may diffuse through the matrix membrane according to a concentration gradient. Alternatively or in addition, the agent may be released by degradation of the polymer matrix membrane material. In either case, the controlled-release material may be provided as a sheet which may be laminated to a surface of the shell. The controlled-release sheet may be layered with the elastomeric polymer and vacuum formed over a mold to form the repositioning appliance. The controlled-release material may be arranged so that it is present on the inside or outside surfaces of the appliance depending on the material and desired application. Or, the controlled-release sheet may be laminated or bonded to a surface of the polymeric shell after forming to supply agent delivery in desired areas. Alternatively, the controlled-release material may be provided as a tablet or similar mass which may be inserted into the polymeric shell of the repositioning appliance. The agent may then elute from the tablet into the oral environment over time.

[0035] In another embodiment, the agent may be held within pores of a material and may elute out at a controlled rate from the pores. The agent itself may be absorbed into the pores of the material, or the agent may be suspended in a carrier which is absorbed into the pores of the material. In the latter case, the agent may be released from the carrier by diffusion and/or by controlled degradation of the carrier material. This may incorporate a rate-controlling mechanism in addition to the controlled-release of the agent from the

pores. As mentioned, in some cases, enzymes in the patient's saliva will activate the release or degrade the carrier material to release the agent. It may be appreciated that the agent may be released by a combination of any of the release methods.

[0036] In a further embodiment, the polymeric shell of the repositioning appliance itself comprises a controlled-release material containing the agent. In this case, at least a portion of a polymeric shell is formed from a controlled release material wherein the rate controlling material controls the rate at which the agent is released from the shell. As previously described, the controlled-release material may be provided in the form of a sheet. Thus, the sheet of controlled-release material may be vacuum formed over a mold of the patient's teeth to form a repositioning appliance itself. In this manner, no additional elastomeric materials may be needed to form the appliance. The controlled-release material may be a polymer matrix membrane, a porous material or any suitable material. Controlled-release may be designed so that the elution rate of the agent corresponds to the repositioning rate of the teeth. The agent may elute throughout the repositioning process, concluding as the teeth reach the desired arrangement prescribed by the appliance.

[0037] In another embodiment, the appliance is made from a polymeric material that exhibits reduced stress relaxation and creep when used as a tooth positioner in the oral cavity. Tooth positioners are made from polymeric materials. Once fabricated the tooth positioners are coated with a thin layer of a polymeric material. This coating serves to protect the tooth positioner from the potentially harmful environmental effects of salivary components, water and temperature. The physical properties of the polymeric coating (e.g. durometer, lubricity, elasticity, etc.) may be adjusted by modifying the polymer chemistry. Furthermore, a wide variety of substances may be combined with the polymeric coating solution to provide ancillary patient benefits. For example, flavorants may be combined with the polymeric coating and released over time to help control oral malodor. Drugs to control gingivitis or treat periodontal disease may also be combined with the polymeric coating. Finally, biocompatible dyes or colorants contained in the polymer matrix may be released when exposed to salivary fluids. The gradual disappearance of the colorant may signify whether or not the tooth positioner is being worn by the patient. The polymeric coatings applied to the dental appliance serve as a protective barrier to the harmful effects of salivary components, temperature and water and can contain flavorants, dyes, polymers, surface active molecules, antimicrobial agents and drugs.

[0038] In a still further embodiment, the releasing means coupled to at least some of the repositioning appliances comprises a reservoir formed in the shell of the appliance in addition to the cavity which receives the teeth. Typically, a rate controlling membrane is disposed over the reservoir wherein the rate controlling membrane controls the rate at which the substance is released from the reservoir. The reservoir may be pre-filled or pre-loaded with an agent or substance for delivery. In this case, the appliance may be ready for insertion or use upon removal from any packaging without the need of loading the appliance with the agent for delivery. If the releasing means is designed for a single delivery period, the appliance may be worn throughout the prescribed repositioning period and then disposed of. If the releasing means is designed for multiple delivery periods,

the reservoir may be replenished with the agent to be released any number of times throughout the prescribed repositioning period. It may be appreciated that any agent, particularly fluoride materials, antibiotics, bleaching materials and breath fresheners, may be delivered to the oral environment in this manner.

[0039] In some instances, it may be desirable to change a visual characteristic of the polymeric shell of an oral appliance. Such appliances comprise a polymeric shell having a cavity shaped to be removably placeable over the teeth and a material on or within the shell that changes a visual characteristic of the shell. Such a change is typically in response to a change in the environment. In some cases, the visual characteristic is a color, such as green, red or blue. Thus, the appliance may appear colored or a particular color under certain environmental conditions, either in the oral environment or when removed. The described material may be a dye which changes color in response to a change in temperature. For example, the dye may change color when the appliance is removed from the mouth and changes temperature from body temperature (37° C.) to room temperature (25° C.). Similarly, the dye may change color when the appliance is rinsed with cool water.

[0040] The appliance can be used to provide an intra-oral drug delivery system. In addition to the drugs described above, other compounds can be used as well. For example, a drug coated appliance can be used to deliver desensitizing medication to sensitive teeth. The drug substance can simply be a small amount of the active ingredient in a desensitizing toothpaste or gel, such as Sensodyne®. The desensitizing agent is dispersed throughout the surface of the appliance and is delivered, at a substantially constant rate, to the patient's sensitive teeth for a relatively extended period of time.

[0041] Although the appliance may be pre-loaded with the agent and ready for use upon removal from any packaging, appliances that are not pre-filled or pre-loaded may require loading prior or immediately prior to placing the appliance over the teeth. Loading may comprise placing the agent in a teeth-receiving cavity. As described previously, the cavities may be filled to any desired level. When the appliance is positioned over the teeth, the teeth will directly contact the agent in the cavities as the teeth are inserted into the cavities. Alternatively, loading may comprise placing the agent into an agent release reservoir in the appliance immediately prior to placing the appliance over the teeth. The agent will then elute from the reservoir into the oral environment when the appliance is in place over the teeth. The elution rate may be controlled by a controlled release membrane which separates the reservoir from the surrounding environment. Loading may also comprise adhering a rate controlling material containing the agent to a surface of the appliance prior to placing the appliance over the teeth. Such a material may comprise a polymer matrix membrane which may be removably or permanently adhered to the polymeric shell of the appliance in desired areas for delivery of the agent. And finally, loading may comprise absorbing the agent into a porous material on or within the appliance immediately prior to placing the appliance over the teeth.

[0042] Repositioning of the teeth with the use of a position adjustment appliance involves placing the appliance over the teeth. However, the appliance is periodically removed for

daily dental hygiene practices and other events throughout the repositioning protocol until the teeth are moved to at least near the desired tooth arrangement. While the appliance is removed from the teeth, the appliance may be replenished with the agent or substance for delivery. Replenishment may be performed immediately prior to each time the appliance is replaced over the teeth or it may be performed according to any prescribed protocol.

[0043] In another aspect, methods for introducing agent delivery to a prescribed tooth repositioning treatment plan are provided. A treatment plan is determined by an orthodontist or practitioner at the outset of orthodontic treatment. The plan involves moving the teeth through a series of intermediate configurations or arrangements to a final desired arrangement with the use of a system of tooth positioning appliances. Each appliance comprises a polymeric shell having cavities which is removably placeable over the teeth and wherein the cavities of successive shells are shaped to reposition teeth from one arrangement to a successive arrangement according to the treatment plan. The entire series of appliances may be provided at the outset of treatment, or a subset of appliances. In any case, the need or desire for delivery of an agent to the oral environment may occur at any point during the course of treatment. In such a case, an agent and/or means for releasing an agent to the oral environment may be coupled to an appliance at any time during treatment.

[0044] Means for releasing the agent may include a number of embodiments, including any such means previously described. Typically, means for releasing the agent comprises a layer including the agent, as previously described, and coupling comprises adhering the layer to at least a portion of a surface of the appliance. When the layer consists essentially of the agent, adhering may involve coating, spraying, dipping or painting the agent on the surface of the appliance. Thus, a pre-formed appliance may simply be coated with the agent prior to insertion in the patient's mouth. When the layer comprises an agent present in or on a carrier or binder, adhering may involve attaching the carrier or binder a surface of the appliance. Similarly, when the agent is encapsulated in the layer, the layer may be attached to the surface of the appliance. The layer may comprise a sheet of rate controlling material wherein the rate controlling material controls the rate at which the agent is released from the layer. In this case, the sheet may be bonded to the surface of the appliance with an adhesive. Alternatively, the sheet may be attached to the surface by press fitting. The sheet and the surface may each be shaped so that they snap or fit together by pressing them together. For example, the sheet may have a formed protrusion and the surface a formed inset, wherein the protrusion fits into the inset when pressed upon the inset and holds the sheet in place. In many instances, the appliance may be porous or have a reservoir which can be loaded with a desired agent at any time the treating professional and/or the patient decide that it is appropriate. For example, an appliance can be immersed in a solution of the agent, allowing the appliance to absorb or adsorb the agent at a particular time.

[0045] In addition, the sheet may be pre-formed to a shape adapted for fitting against the surface of the appliance or a surface of the teeth or gingiva. For example, the sheet may be pre-formed to reflect the shape of the surface of one or more teeth or the gingiva, particularly along the gingival

margin. The preformed sheet may then be held against that surface when the sheet is coupled to the appliance and the appliance is placed over the teeth. Coupling may involve any means of attaching the sheet to the appliance. In particular, the pre-formed sheet may further comprise an adhesive layer which may provide bonding of the sheet to the surface of the appliance.

[0046] The material to make the appliance of FIG. 2A can be supplemented with additional fillers such as electrically conducting fillers, magnetic fillers, illuminating fillers, piezoelectric fillers, and/or light sensitive fillers. The material properties of the appliance made with or without these additional fillers such as modulus, electrical resistance, material permeability, and birefringence (degree of orientation of the material or stress), illuminating patterns or patterns under special light sources may change after the appliance is worn over time, as these properties are altered due to changes in structure, organization, and/or spatial spacing between the fillers. For example, it is well established that electrical conductivity of filled composites scales with filler volume concentration according to percolation theory. Therefore, mechanical deformation or thermal expansion of the non-conductive polymer matrix will lead to increased average inter-filler spacing, or decreased filler volume concentration, and consequently decreased electrical conductivity. Examples of electrically conductive fillers include metals, graphite, electrically conductive polymers, semiconductors, and superconductors. These changes in properties can be used as an indicator for compliance and can be diagnosed by instrumentation. Similarly, separation of conductive fillers will also lower thermal conductivity, which can also be measured by instrumentations. If the fillers have magnetic behavior in the presence of external stimulation, such as diamagnetics (Cu, Au, Ag, etc.) and paramagnetics (e.g. Al, Cr, Na, Ti, Zr, etc.); or exhibit intrinsic magnetic properties, such as ferromagnetics (Fe, Co, Ni, etc.), antiferromagnetics (e.g. MnO), and ferromagnetics (MFe₂O₄), then separation of the filler spacing due to mechanical deformation of the polymer matrix can also lead to decreases in magnetic properties above the Curie temperature. Mechanical deformation of composites with illuminating fillers, such as those that exhibit luminescence, fluorescence, or phosphorescence, will result in decreased illumination intensity. Bending deformation or displacement of piezoelectric fibers can result in electrical potentials which can be either measured, or used to activate other electrically driven indicators (e.g. low power LED light). Fillers with optical properties which depend on external electric field, for example those that shift their absorption coefficients in the V, IR, or visible spectrum can also serve as indicators of matrix deformation.

[0047] FIG. 2B shows a second embodiment of FIG. 2A. In this embodiment, an appliance 17 has a plurality of delivery nozzles 18A-18C that project from the appliance 17 to contact the patient's gum tissue on the side of the gum or in a periodontal pocket. The nozzles 18A-18C can be on either the frontal side, the lingual side, or both sides of the teeth on the jaw 16. Optionally, one or more reservoirs 19A-19C can store extra drug/agent for delivery through nozzles 18A-18C. In one embodiment, reservoirs 19A, 19B, and 19C can contain the same drug or substance. In another embodiment, reservoirs 19A, 19B, and 19C can each contain a different drug/substance. In yet another embodiment, reservoir 19A and 19C can contain the same drug and reservoir

19B can contain a different drug/substance. The combination of drug storage as discussed above is illustrative only and any suitable combination for storing a plurality of drugs or substances in a plurality of reservoirs 19A-19C can be used.

[0048] FIG. 2C shows a cross-sectional view of the appliance of FIG. 2B on an exemplary tooth. As can be seen, the nozzle 18A either stores the drug or agent or receives drug/agent from the reservoir 19A. Moreover, the nozzle 18A is adapted to be inserted into the gum of the patient to deliver the drug/agent to the patient. FIG. 2D is a cross sectional view of FIG. 2C without the tooth and gum line.

[0049] Referring now to FIG. 2E, another embodiment of a drug/agent delivery device is shown. In this embodiment, a plurality of drug/agent containers or modules 23 are positioned in an inside lining of a removable dental appliance 21. The appliance 21 is fitted over a tooth 25. During chewing or other oral activities, the appliance 21 carrying the modules 23 is pressed toward the tooth 25. At a predetermined pressure or force, one or more of the modules 23 burst, releasing the drug or agent into the oral cavity. In addition to being positioned inside the lining of the appliance 21, the modules 23 can also be positioned on an outside lining of the appliance 21 as well.

[0050] Turning now to FIG. 2F, yet another embodiment of a drug or agent delivery device is shown. In this embodiment, an attachment 27 is mounted on a tooth 25. The attachment contains a first material that is inactive absent the presence of a second material. The second material is coated on an appliance 29 and is also inactive in the absence of the first material. When the appliance 29 is worn over the tooth 25 and the attachment 27, the first and second materials react to form a drug or an agent suitable for intra-oral delivery.

[0051] Referring now to FIG. 3, another drug delivery system is shown. In this system, brackets and wires are used to effect tooth positioning as well as drug delivery. On the frontal side of the teeth, a base 20 and a plurality of brackets 24 are positioned on the teeth. Additionally, a wire 28 is positioned in the slots of the brackets 24. The base 20 and the brackets 24 contain drug/agent to treat the patient.

[0052] In an alternative embodiment, the fixed appliances can be mounted on the lingual side of the teeth as well. For example, a base 30 and a plurality of brackets 34 are placed on the rear or lingual side of the teeth, and a wire 38 links the base and brackets for orthodontic treatment and drug delivery.

[0053] In yet another alternative embodiment, the drug/agent can be delivered using bases and brackets and wires on both sides of the teeth such as that shown in FIG. 3.

[0054] Reservoirs can be positioned on the base and brackets to provide treatment drugs or agents. FIG. 4A shows a cross-sectional view while FIG. 4B shows a perspective view of a bracket with a reservoir. As shown in FIGS. 4A-4B, a bracket body 42 has a base region 46 and a slot 47 to receive a wire (not shown). Above the body 42 is a reservoir 44 that contains drugs or agents for delivery to the patient. The bracket body 42 and reservoir 44 can be of any suitable metal, or can be of a translucent or transparent plastic material or any suitable biocompatible metal. These general types of materials are commonly used in the practice of orthodontic care. It should be understood that the size and

shape of the bracket body 42 and reservoir 44 are not critical and the exemplary bracket is described for purposes of illustration.

[0055] FIG. 4C shows another embodiment where the substance can be stored in a cap 48 that is received by the slot 47. The cap 48 can be used with a conventional bracket without the reservoir 44 as well as with the bracket of FIG. 4A. When used with the bracket of FIG. 4A, the substance in the cap can be the same as the substance in the reservoir 44 or can be different from the substance stored in the reservoir 44.

[0056] FIG. 4D shows yet another embodiment where the substance can be stored in a band 52 that encircles the slot 47. The band 52 can be used with a conventional bracket without the reservoir 44 as well as with the bracket of FIG. 4A. When used with the bracket of FIG. 4A, the substance in the band 52 can be the same as the substance in the reservoir 44 or can be different from the substance stored in the reservoir 44. Optionally, the band 52 can receive a substance from a band reservoir 54.

[0057] FIG. 4E shows yet another embodiment with a bracket 56 that has an opening 57 extending from one side of the bracket 56 to the other side of the bracket 56. A substance is provided in a housing 58 which can be ball-shaped or box-shaped, among others. A wire 59 is attached to the housing 58 and the wire 59 can be threaded through the opening 57. After reaching the other side of the bracket 56, the wire can be twisted or bent or otherwise secured to the bracket 56, as shown by a bent wire 59A. The bent wire secures the housing 58 to the bracket 56 for delivery of substances to the patient.

[0058] FIG. 5A shows another embodiment where a second reservoir is mounted on a second side of the teeth opposite to the side where the bracket of FIG. 4A is mounted. In this embodiment, a second reservoir 50 contains additional drugs or agents. The second reservoir 50 is connected to the reservoir 44 through a pipe 52 to replenish the drug or agent as needed.

[0059] In another embodiment, the reservoirs 44 or 50 can be recharged using a needle to inject additional drug/agent to the reservoirs. Alternatively, the reservoir 44 or 50 can be replaceable to replenish the drug/agent.

[0060] FIG. 5B shows another embodiment where a bracket 64 is used as a mount or support for a drug/agent housing 66 on a tooth 60. In this embodiment, the housing 66 abuts the gum or a surface of the oral cavity to expedite delivery of drug/agent to the patient's body.

[0061] FIG. 5C shows another embodiment where the bracket 64 is used as a mount or support for a drug/agent housing 68 on the tooth 60. In this embodiment, the housing 68 is spaced apart from the gum or a surface of the oral cavity to deliver the drug/agent to the patient's body.

[0062] FIG. 5D shows yet another embodiment for delivery of drug or therapeutic agent. A permeable implant 70 is mounted on the patient's gum 71. A post or abutment 73 with a screw or threaded end 72 is mounted on the implant 70. A crown-shaped housing 74 contains a drug or agent that seeps or permeates through the abutment 73 and the implant 70 to be delivered to the patient's body.

[0063] FIG. 5E shows a screw embodiment where drug or agent is embedded in a screw having a head 76 and a threaded portion 75. The screw is tapped into the patient's gum where it delivers the drug or agent into the patient's body. In addition to screws, micro-staples can be used to deliver drugs to the body. Moreover, dentures and partial dentures can have drug(s) or agent(s) embedded therein to deliver drug to the patient's oral cavity or body. In addition, the drugs or agents can be embedded in spaces between teeth.

[0064] FIG. 6A shows another embodiment where energy is applied to an appliance 78 to affect teeth movement or drug delivery. In this embodiment, electricity is stored in an energy source 83 such as a battery. A switch 81 is used to deliver energy to the oral cavity. The switch 81 is controlled by electronics 79 such as a microcontroller. The electronics 79 delivers a predetermined amount of energy to treat the patient or to deliver drug.

[0065] FIG. 6B shows another embodiment where energy is applied to wires 80 and 82 to effect teeth movement or drug delivery. In this embodiment, electricity is stored in an energy source 88 such as a battery. A switch 84 is used to deliver energy to the oral cavity through wires 80 and 82. The switch 84 is controlled by electronics 86 such as a microcontroller. The electronics 86 delivers a predetermined amount of energy to treat the patient. The energy in one instance can be low-level electrical current to promote healing at the bone level. In another instance where the energy source 88 is connected through switch 84 to a material such as nichrome, the energy can be low level heat. In another instance where the energy source 88 is connected through switch 84 to a light emitting diode (LED), the energy can be light and when the LED is in a lasing mode, the energy can be a laser beam. The energy can be a magnetic field in another instance where the energy source 88 is connected through switch 84 to an inductor.

[0066] Ultra-sound can be used as well where the energy source 88 is connected through switch 84 to an ultrasound vibratory source or transducer. The transducers can be electronically activated to vibrate and emit ultrasonic pulses to promote bone healing. In addition to healing the bone, some of the pulses penetrate the tooth and are returned to other transducers on a sensor array. These echo or reflected pulse signals, after being detected by transducers on the array, can be collected, analyzed and compared to produce a recreation of the tooth or dental structure being examined. By collecting reflected or scattered signals from as many angles as possible, the electronics will have sufficient time-of-flight measurements to perform a tomographic computation to model or map the tooth volume.

[0067] Vibrations can be used to inflame or irritate the bone structures to promote tooth movement as well. In one embodiment, the appliance is coated with a material that can expand and contract upon receipt of an electrical stimulus. Electroactive polymer composites, fabricated from an organic filler possessing very high dielectric constant dispersed in an electrostrictive polymer matrix, can be used as dental actuators. The composite can have a matrix made from electrostrictive poly(vinylidene fluoride-trifluoroethylene), an electroactive copolymer and a filler such as an organic semiconductor, copper-phthalocyanine. The composite acts as artificial muscles. Upon actuation, they can

repetitively contract and expand to create vibrations on the teeth to encourage teeth movement.

[0068] Alternatively, memory-materials such as nitinol can be used and the contraction/expansion can be controlled. Heat, electrical, or microwave energy can be used on other materials to induce them to change state and to inflame or stress the bone/gum structure to induce teeth movement.

[0069] In another embodiment, a wire can be attached directly to the teeth or indirectly to the teeth using a removable appliance and the wire can be repetitively wound and unwound using a micro-motor. Such repetitive movements apply stress that inflame or irritate the gum or bone structure to enhance teeth movement.

[0070] Thus, as discussed above, FIGS. 6A-6B show that the substance (in this case battery 83 or 88) provides energy to the oral cavity. The energy can be physical, electric, light, heat, sound, magnetic or electromagnetic energy.

[0071] In addition to injecting energy, the devices of FIGS. 6A-6B can be used to irritate or inflame the oral structure. For instance, the devices can be used to inflame gingival or the bone structure of the teeth to encourage teeth repositioning.

[0072] In another embodiment, the appliances can be used to enhance drug delivery by using electrical current to induce drug movement. For example, the drug molecules can be transported between one electrical pole to another electrical pole. Another implementation provides a positive current on one side of the appliance, and a negative current on the other side of the appliance to force the drug through the gum or dental tissue.

[0073] In another embodiment, the appliance induces a change in the polarity of the teeth. The tooth is normally negatively charged and the drug in the appliance is positively charged. Opposite charges attract and bond to each other and the drug or agent can be attached to the tooth surface by "ionic bonding".

[0074] In yet another embodiment, the appliance containing drug can be configured so that positively charged ions are transferred to the teeth. The tooth polarity changes from negative to positive. The positively charged tooth ions repel the positively charged ions from other substances. For example, plaque ions are repelled from tooth ions such that plaque can be removed from the oral cavity.

[0075] In yet another embodiment, the appliance applies submucosal iontophoresis to accelerate tooth movement. Iontophoresis stimulates osteoclasts in the periodontal pressure side and osteoblasts in the tension side.

Agents to Accelerate or Decelerate Movement

[0076] In one embodiment, the substance accelerates tooth movement by degrading the matrix. Matrix degradation can be stimulated either directly or indirectly. Chemical agents may act as enzymes to directly breakdown structural proteins in the matrix. Proteases degrade protein, elastases degrade elastin, collagenase degrades collagen, among others. Other drugs or hormones such as relaxin, estrogen, or nicotine may act on cells within the matrix and cause those cells to secrete endogenous matrix degrading enzymes. Many of these naturally occurring enzymes are known as matrix metalloproteases (MMPs) and in the periodontal

space these enzymes include MMP-1, MMP-2, MMP-3, MMP-8, and MMP-9. The expression and function of these enzymes is usually under tight control, in part, by a concomitant expression of a group of molecules known as tissue inhibitors of matrix metalloproteases (TIMPs).

[0077] A large number of drugs have been developed to prevent matrix breakdown. These drugs are typically useful as anti-inflammatory agents or anti-cancer therapies. Some of these candidates have been used to prevent or treat periodontitis. A very few drugs are available to stimulate matrix breakdown and those are commonly used for indications like wound debridement, breakdown of blood clots, or stimulating gastrointestinal digestion. Their utility in the setting of orthodontic remodeling would need to be tested in appropriate preclinical models.

[0078] One exemplary drug can be Granulex or Xenaderm™ whose active ingredient is trypsin. This drug is indicated for wound debridement, wound healing, or varicose vein treatment. This ingredient breaks down many different types of protein. Alternatively, another active ingredient such as hyaluronidase can be used to degrade hyaluronan which is thought to have a role in resisting compressive forces in tissue. Also, elastase can be used to degrade elastin preferentially and may help to both accelerate remodeling and prevent relapse.

[0079] Another exemplary drug can be Alteplase or Activase® whose active ingredient is tissue plasminogen activator. These drugs are indicated for thrombolytic therapy. In the presence of a thrombus Activase binds to fibrin and converts plasminogen to plasmin to stimulate fibrinolysis. These drugs may only work in the context of blood clots.

[0080] Examples of other exemplary drugs are Arco-Lase®, Creon®, Kutrase®, Ku-zyme®, Ultrase®, and Vio-case®, whose activity depends on a combination of enzymes: amylolytic, proteolytic, cellulolytic and lipase. These drugs are indicated for the treatment of gastrointestinal disorders due to poor digestion. The drug, Arco-Lase, comes in soft, mint flavored tablets. All these drugs warn that they may irritate oral mucosa, which may be an indication that they could work to soften gum tissue as well as degrade food proteins.

[0081] Examples of other exemplary drugs are Accuzyme®, Gladase®, and Panafil® whose active ingredient is papain. This drug is indicated for treatment of wound debridement. Papain combined with urea dissolves non-viable protein but supposedly leaves viable tissue intact.

[0082] Another exemplary drug can be Potaba® whose active ingredient is aminobenzoate potassium. This drug is indicated for antifibrosis therapy for scleroderma, Peyronie's disease, dermatomyositis and morphea. This ingredient is part of the vitamin B complex and is reported to soften tissue with long term use.

[0083] Another exemplary drug can be Aldurazyme® or Laronidase, whose active ingredient is alpha-L-iduronidase. This drug is indicated for treatment of mucopolysaccharidosis. This ingredient is a lysosomal hydrolase that breaks down the glycosaminoglycans: dermatin sulfate and heparan sulfate.

[0084] Another class of enzymes that may help to loosen gum tissue for the purpose of accelerating tooth movement

is the elastase family of enzymes that break down elastin. Addition of these enzymes or induction of endogenous elastase activity could also serve to prevent tooth relapse following successful orthodontic tooth movement. Elastase enzymes are produced by a number of inflammatory cells for example neutrophil elastase, leukocyte elastase, granulocyte elastase or macrophage elastase (which is also called MMP-12). As described below, agents or activities that stimulate inflammation, cause an increase in the local concentration of these inflammatory cells and therefore an increase in the local concentration of elastase enzymes.

[0085] Additional enzymes that would also augment tissue degradation include hyaluronidase and cathepsin. Hyaluronidase is an enzyme found in mucous membranes that specifically degrades hyaluronic acid which is part of the glycosaminoglycan matrix molecules important for resisting compressive force. The cathepsin family of lysosomal enzymes is a large and varied family of cysteine proteases important in many disease processes that involve tissue disruption. Cathepsin B, for example, is known to play a role in demyelination, emphysema, rheumatoid arthritis and neoplastic infiltration. Cathepsin B is also known to be elevated in gingival crevicular fluid during orthodontic tooth movement and is thought to be involved in extracellular matrix degradation in response to mechanical stress. Another cathepsin, cathepsin K, is upregulated in odontoclasts and osteoclasts during tooth movement and may play a role in root resorption during this process.

[0086] In general, the addition of any enzyme that is capable of breaking down a component of the gingival extracellular matrix is capable of accelerating tooth movement. An alternative means to disrupt the tissue matrix is by addition of compounds that can interfere with the normal interaction between different components of the matrix architecture. For example, a family of proteins known as integrins serve to link cells to the extracellular matrix. Addition of a class of agents known as disintegrins can block this interaction and loosen the connective structure of the matrix. Disintegrins are found in snake venoms and are useful to this species because of their ability to facilitate tissue penetration of the venom. Disintegrins found in many snake species are called variously albolabrin, applagin, batroxostatin, bitistatin, echistatin, elegantin, flavoridin, halysin, kistrin, triflavin, and trigramin.

[0087] Primary constituents of the extracellular matrix are collagen, elastin, fibronectin, laminin, integrins, proteoglycans and glycosaminoglycans. Additional constituents are fibrillin, versican, link protein, entactin, tenascin, vitronectin, decorin, cadherin and many others. Many of these components bind to one another to add rigidity and structural integrity to the tissue matrix architecture. Often these interactions are through specific binding sites involving an RGD (arginine-glycine-aspartate) peptide sequence. Antibodies or other binding agents that target these binding sites are capable of disrupting matrix integrity and loosening the tissue. Specific antibodies have been developed to all of these matrix proteins, though only the subset of enzymes that target epitopes important in protein-protein interactions are likely to cause tissue matrix disruption. Antibodies or other binding agents will be effective if they have an affinity for the binding sites that is greater than that of the native proteins. One means of generating a large number of agents

capable of binding at, for example, an RGD site is by screening with phage display peptide libraries such as described in Odermatt et al.

[0088] Tissue extracellular matrix degradation may be brought about by direct application of enzymes and binding agents as described above, or through indirect means by addition of agents that stimulate the overexpression of endogenous enzymes. An example of this type of agent includes drugs that alter the expression or activity of matrix metalloproteases (MMPs). MMPs are a family of structurally related, protein-degrading enzymes that require calcium ions for structural conformation and zinc ions in their active site for function. The MMP enzymes can be administered either alone or in combination to directly impact tissue degradation. As mentioned previously, MMP-1, MMP-2, MMP-3, MMP-8 and MMP-9 are the matrix degrading enzymes known to be active in the periodontal space. Matrix metalloproteases are also known as matrix metalloproteinases, collagenases, gelatinases, or CLGs. For example, depending on the nomenclature used, MMP-2 is also called collagenase type 4 (A), gelatinase A, or CLG 4 (A). Some MMPs are known by additional names due to the fact that their discovery preceded knowledge of the family characteristics. For example, MMP-3 is also known as stromelysin-1 or transin. The MMP enzymes listed above have been purified and are available commercially.

[0089] Collectively, the MMP family of enzymes is capable of digesting almost all of the components of the extracellular matrix. They often work best in concert whereby an MMP isotype with selective collagenase activity will cleave the type 1 collagen triple helix allowing access to additional MMP enzymes which then further degrade the protein. MMP-3, in contrast to MMP-1 and MMP-2 does not break down type I collagen but can degrade proteoglycan and fibronectin which are other important constituents of the extracellular matrix. As they occur naturally in periodontal tissue MMP activity is finely balanced by the presence of endogenous enzyme inhibitors known as tissue inhibitors of metalloproteases (TIMPs). Adding exogenous MMPs to the tissue can alter the balance of activity to bring about relatively more matrix degradation and tissue disruption that may aid in tooth movement.

[0090] An exemplary drug that may work to accelerate tooth movement by stimulation of endogenous MMP activity is Prepidil® (dinoprostone) whose active ingredient is prostaglandin E2. This drug is indicated for treatment of induction of labor. Prostaglandin E2 has been shown to enhance MMP-1 (collagenase) and sometimes MMP-3 (stromelysin) expression in human gingival tissue. Another exemplary drug that contains the same active ingredient is Prostin E2® which is indicated for termination of pregnancy.

[0091] Another exemplary drug can be Fluprostenol. This drug is a potent luteolytic agent with prostaglandin F2alpha activity. Research shows that it can increase MMP-1 production and degrade connective tissue in human gingiva.

[0092] Another exemplary drug can be Nicoderm®, Commit® and Nicorette®, whose active ingredient is nicotine. This drug is indicated for treatment of smoking cessation. This ingredient has many effects such as vasodilation, but research shows it can increase collagenase activity and matrix turnover in gingival tissue.

[0093] Another example of an agent that stimulates the overexpression of endogenous enzymes is keratinocyte-derived collagenase stimulatory factor also known as strati-fin. Delivery of this agent can cause upregulation of collagenase enzymes in fibroblasts present in gingival tissue. An even more direct way to stimulate overexpression of matrix degrading enzymes is to use gene therapy techniques to either transfect local cells with constructs encoding these enzymes or with enhancer or promoter elements capable of stimulating endogenous gene transcription of those particular enzymes. For example, overexpression of manganese superoxide dismutase is known to cause activation of MMP-2. Agents that elevate the intracellular concentration of cyclic adenosine monophosphate (cAMP) are also capable of promoting MMP-2 overexpression, increasing the activity of this enzyme and decreasing collagen content in tissue. Examples of agents with this capability are isoproterenol, prostaglandin E2 and forskolin. Relaxin is another agent that is capable of enhancing MMP-2 production.

[0094] In general any agent that triggers an inflammatory response can bring about stimulation of MMP overexpression and matrix degradation. Another large family of molecules of interest in this regard is the cytokine family of molecules. Cytokines are agents usually secreted by cells to bring about a response in another cell. Thus, they are important in cell to cell communication. A number of common inflammatory cytokines have been elucidated and many more are likely to be discovered and characterized in the future. Inflammatory cytokines are released after injury and help to recruit additional inflammatory cells into the area of tissue damage. Orthodontic tooth movement usually involves a mild inflammatory response. If exacerbated, this inflammatory response will likely promote additional tissue degradation and may speed the process of tooth movement. The most commonly known inflammatory cytokines are interleukin-1 (IL-1), interleukin-6 (IL-6), tumor necrosis factor-alpha (TNF α) and transforming growth factor-beta (TGF- β).

[0095] There are many ways to stimulate an inflammatory response beyond direct addition of inflammatory cytokines. Inflammation can be brought about by virtually any means of causing local tissue damage. Mechanical force such as pushing, pulling or stretching the tissue can trigger release of local pro-inflammatory cytokines. Tearing or abrasion of either soft tissue or bone can similarly trigger an inflammatory reaction. Addition of an irritant such as a powder, polymer, or any type of foreign body can incite inflammation. Alteration of local pH into either an acidic or basic range beyond normal physiological pH can cause inflammation. Elevated temperature can have a similar effect as can the addition of other energy sources such as ultrasound, or electrical energy.

[0096] Regardless of what means is used to stimulate the activation of local tissue degrading enzymes there is a need for limiting this activation so as not to cause significant and irreversible tissue damage. What is sought is a mild enhancement of the inflammatory response normally associated with orthodontic tooth movement. The ability and mechanisms by which these limitations can be established will depend on the stimuli used to enhance inflammation. If agents or enzymes are administered directly, their activity can be controlled by monitoring the dose-response relationship and choosing the most appropriate concentration. If

indirect stimulators of endogenous enzymes are used then the tissue itself may provide some regulatory feedback (e.g. upregulation of TIMPs) to modulate and limit the overall response. The ultimate goal in this case is to strike the right balance to bring about moderate tissue disruption.

[0097] In one implementation, the drug or bioactive agent assists in a "retention" phase, without which there is a tendency for the teeth to return to their initial position (relapse). The underlying cause for this relapse appears to reside in the gingival tissue which, unlike bone and the PDL, is not resorbed during orthodontic treatment but is compressed and consequently retracts. On the pressure aspect of the gingiva there is an increase in the number and size of elastic fibers and an increase in collagen. The elastic forces stored in the compressed gingiva can exert pressure on the tooth and cause relapse after the release of retention. Procedures such as gingival circumferential fiberotomy have been introduced to disconnect the compressed gingiva from the tooth and have demonstrated some success in preventing tooth relapse.

[0098] Bioactive agents can accelerate tooth movement. The bioactive agents described above work primarily by enhancing collagen or elastin degradation. If delivered to the appropriate local tissue bed these agents should, then, limit the increase in collagen and elastin accumulation on the pressure side of the gingiva and reduce the tendency to relapse. There are, however, other mechanisms to prevent tooth relapse. One way to chemically stabilize tooth position after completion of the orthodontic movement involves increasing the number of chemical crosslinks between collagen fibers, particularly on the tension aspect of the tooth. Increased crosslinking provides more structural stability to the new fiber orientation in the gingival tissue. Formaldehyde and glutaraldehyde are the most well known agents capable of crosslinking collagen and these agents are commonly used to treat bioprosthetic tissue prior to use of that tissue as a medical implant. Standard formulations of formaldehyde and glutaraldehyde are likely too toxic to be used in situ, but may be modified to reduce their tissue toxicity.

[0099] Chemical crosslinking agents can be used to crosslink extracellular matrix components for many different indications. For example, Genipin is a relatively non-toxic, naturally occurring crosslinking agent that can be used. Carbodiimide is considered to be a somewhat less toxic crosslinking agent, though at least one study showed that genipin was better able to stimulate intermolecular collagen crosslinks compared to carbodiimide. Intermolecular rather than intrahelical crosslinks are more likely to bring about the desired tissue stabilization. 1,6-diaminohexane (DAH) is also an effective collagen crosslinking agent that has been shown to be slightly less toxic than carbodiimide especially in the presence of glycosaminoglycans (which are naturally occurring in gingival tissue). Dimethyl 3,3'-dithio-bispropionimidate is yet another example of a crosslinking agent reported to be more biocompatible than standard agents like glutaraldehyde

[0100] Another class of compounds that may be useful is the reducing sugars including glucose, ribose and derivatives of these sugars. The slow crosslinking reaction between reducing sugars and biological amines leads to the development of advanced glycation endproducts (AGEs). AGEs accumulate over the course of a person's lifespan and

a number of detrimental conditions have been attributed to this accumulation including increased vascular and myocardial stiffness, endothelial dysfunction, altered vascular injury responses and atherosclerotic plaque formation. In the setting of orthodontic applications, however, increased crosslinking for a limited period of time could prove beneficial and these agents are relatively simple sugars not associated with any additional toxicity. Acceleration of AGE-related crosslinking can be brought about by increasing the concentration of reducing sugars and also by application of external energy such as UV irradiation.

[0101] The bioflavonoids is another broad class of compounds that could prove very useful in this endeavor. They are exemplified by molecules such as riboflavin, catechin and rutosides. Many of these compounds are found naturally in food substances like red wine and green tea. They tend to be very biocompatible but are also known to promote the crosslinking of collagen either alone or in combination with adjunctive energy like UV-A or rose Bengal/white-light irradiation. In the case of riboflavin-UVA, this treatment has been used clinically to promote collagen crosslinking of the sclera to increase its biomechanical strength for the treatment of progressive myopia.

[0102] Although it appears that the accumulation of extracellular matrix proteins in gingival tissue has an important role in tooth relapse, there is also evidence that bone remodeling plays a part. Experimental data from the School of Dentistry in Tohoku University, Japan, showed the ability of a bisphosphonate (risedronate) to prevent tooth relapse. Risedronate is a potent blocker of bone resorption. When applied topically during the phase of orthodontic tooth movement, it reduced tooth movement. When applied during the retention phase, it was able to inhibit relapse.

[0103] In another embodiment, the substance can be anesthetics and analgesics such as benzocaine, lidocaine and prilocaine, among others, that are locally released through the appliance. These substances may promote patient compliance for appliance usage/wear, and also for the palliative relief of oral discomfort due to intraoral ulcers, cancer sores, and other lesions associated with trauma, disease, or surgical procedures.

[0104] In yet another embodiment, the drug can be nicotine to relieve patient discomfort or to treat another disease. As discussed in U.S. Pat. No. 4,215,706, the content of which is incorporated by reference, tobacco (donor tobacco) is contacted with a receiving substrate on the appliance which has been treated with a strong acid or an ammonium salt of a strong acid. Part of the nicotine in the donor tobacco is transferred from the donor tobacco to the receiving substrate. Thereafter the donor tobacco and the substrate may be separated. The donor tobacco has a reduced nicotine content for pain relief or medical treatment.

[0105] In yet another embodiment, the appliance can be used to provide a local release of breath fresheners such as menthol, peppermints, spearmints, wintergreen, zinc gluconate, citrus, clove and thymol, among others, that may promote patient compliance to facilitate treatment. More breath freshener information is shown in US Patent Publication No. 20040115137, the content of which is incorporated by reference.

[0106] Additionally, the substance can prevent tooth decay through fluoride treatment. Treatments include toothpastes,

gels, rinses and varnishes. Gum disease, such as gingivitis or periodontitis, is caused by bacterial growth associated with dental plaque and calculus deposits. The most common recommendation for preventing such bacterial growth is to mechanically remove the plaque from the tooth surfaces. However, chronic gingivitis and tooth decay have plagued many individuals who in fact comply with good oral hygiene methods and plaque removal. This may be due to a variety of factors including genetic predispositions, illnesses, mouth breathing, and medical treatment programs. In such cases, bacterial control may be accomplished with the use of antibacterial drugs. A common antibacterial agent shown to be effective in reducing the activity of many common strains of oral flora is chlorhexidine. Chlorhexidine is a cationic biguanide microbicide with a broad spectrum of activity against many forms of bacteria and fungi. Therefore, it has been a popular agent in many studies of gingivitis reversal. Chlorhexidine has traditionally been delivered to the oral environment through the use of rinses, such as Peridex® (Proctor and Gamble). Sustained delivery to the gingiva has also been attempted with the use of chlorhexidine impregnated dental floss and dental appliances, such as trays or mouthguards. Another frequently prescribed antibacterial agent is tetracycline. Tetracycline is a broad spectrum antibiotic which is effective against virtually all common groups of pathogenic bacteria, both gram positive and negative. Tetracycline may be combined with an antifungal agent, such as amphotericin, to provide activity against fungi. Tetracycline has traditionally been delivered to the oral environment through systemic administration, although localized delivery has been attempted with the insertion of tetracycline-filled hollow fiber devices into periodontal pockets and the use of tetracycline laden dental appliances, such as trays and mouthguards. In addition, a number of other antibacterial drugs are available for dental and periodontal therapy.

[0107] Cosmetic treatments often include tooth bleaching or whitening and breath freshening products. Discolorations of enamel and dentin may occur due to aging, consumption of staining substances (coffee, tea, colas, tobacco), trauma, staining due to systemic tetracycline (antibiotic) therapy, excessive fluoride, nerve degeneration and old dental restorations. Bleaching lightens these discolorations for a whiter or brighter appearance. Typically, a bleaching gel is placed in a thin custom-fitted tray that fits over the teeth. The tray is worn at night for usually 10 to 14 days and may require periodic re-bleaching treatments for approximately one or two nights every six months. Breath freshening products are often used by patients to treat halitosis or for enjoyment of the taste. These include a variety of sprays, rinses, mints, gums, or candies, to name a few.

[0108] Additionally, the substance can include chemicals that irritate the gum or bone. Alternatively, the substance can inflame a bone.

[0109] Often the use of a combination of drugs or bioactive agents can impart more benefit than the use of any single agent. The appliance used to deliver therapeutic or cosmetic agents to oral tissue can be easily adapted to deliver more than one agent and can also be adapted to deliver specific agents to select locations within the oral tissue. For example, a drug that accelerates collagen and/or elastin degradation might be delivered to the pressure aspect of the gingiva where there is typically an increase in the number and size

of collagen and elastic fibers that oppose tooth movement. Simultaneously, the appliance might deliver an agent that promotes the crosslinking of collagen to the tension aspect of the gingiva to help stabilize the tooth movement achieved with the appliance. In one embodiment, reservoirs **19A**, **19B**, and **19C** (**FIG. 2B**) can contain the same drug or substance. In another embodiment, reservoirs **19A**, **19B**, and **19C** can each contain a different drug/substance. In yet another embodiment, reservoir **19A** and **19C** can contain the same drug and reservoir **19B** can contain a different drug. Thus, in one example bleaching agents can be stored in one reservoir and delivered to the tooth itself while a second reservoir can store and deliver an agent capable of accelerating tooth movement to the gingiva surrounding the tooth.

[0110] Just as different agents need not be delivered to identical locations within the oral tissue, different agents need not be delivered at the same time. It may be advantageous to deliver one agent at the beginning of orthodontic treatment and a different agent at another point during the treatment. An example of this treatment regimen would be delivery of agents to accelerate tooth movement during the first weeks of orthodontia and delivery of agents to prevent tooth relapse following the period of tooth movement.

[0111] In some cases it is necessary to add one agent to modify the activity of another agent. For example, a buffering agent may be needed to alter the pH of a drug so as to make the therapeutic agent less caustic. In another case it might be necessary to add one agent to stabilize or activate the therapeutic agent once it has been released from the appliance. An alternative exemplary case would be the use of more than one agent that have the same general effect as, for example, two agents that are likely to accelerate tooth movement. Two or more agents may be employed rather than one either because they will act synergistically by employing different modes of action to bring about an effect or because they have different unwanted side effects that can be reduced by lowering the dose delivered of each but maintaining a beneficial therapeutic effect because of the ability of the agents to work together in concert.

[0112] In yet other implementations, a diagnostic indicator can be provided. The diagnostic indicator is similar in device construction to the compliance indicator, and utilizes the inwards diffusion strategy, where biochemical analytes from the external environment are allowed to diffuse through the membrane to react with the contents within the reservoir chamber. Thus, biomarkers from the external environment diffuse through the membrane, and react with reagents inside the content to directly or indirectly induce color change or chemical change that can be quantified through human eye or laboratory testing or computerized vision systems. As more biomarkers diffuse into the diagnostic indicator, the content color changes, for example increases in brightness and value. Possible biomarkers include enzymes, pH, glucose, salt, oral film, plaque, microorganisms that may exist in the oral cavity and amount of saliva.

[0113] With its vast antimicrobial arsenal, saliva represents a remarkable evolutionary selective advantage for the host against invading pathogens such as HIV, the fungus *Candida albicans*, and a host of bacteria associated with oral and systemic diseases. Secretory antibodies, for example, directed against viral pathogens such as poliovirus and cold viruses, as well as the anti-HIV agent SLPI, are found in

saliva. Large salivary glycoproteins called mucins appear to have antiviral properties as do cystatins, a family of cysteine-rich proteins that are active against herpes viruses.

Appliance for Diagnosis

[0114] The salivary glands and their secretory product, saliva, forge a strong link between oral and systemic health. Salivary function is extremely sensitive to changes in our general well-being, ranging from subtle effects of over-the-counter cold medications to the devastation of life-threatening disease. **FIGS. 7A and 7B** show exemplary appliances that can be used to diagnose and optionally deliver drugs to a patient.

[0115] In one embodiment shown in **FIG. 7A**, an intra-oral device that performs medical diagnostics is shown. In this device, an exemplary removable appliance **515** fits over teeth on a jaw. The appliance includes a sensor **517** whose output is processed by a processor **519**. The sensor **517** is adapted to sense a pathogen or a salivary component and sends a signal to the processor **519**. The processor **519** detects the presence or absence of one or more medical conditions and outputs a diagnosis accordingly. The diagnosis can be transmitted to a remote computer using radio frequency or light frequency such as infrared transmission, among others.

[0116] In one embodiment, the sensor **517** senses an antimicrobial agent. The agent can be formed in response to pathogens such as HIV, the fungus *Candida albicans*, and a host of bacteria associated with oral and systemic diseases. The sensor **517** can detect secretory antibodies, for example, directed against viral pathogens such as poliovirus and cold viruses, as well as the anti-HIV agent SLPI. The sensor can also detect salivary glycoproteins called mucins that have antiviral properties as do cystatins, a family of cysteine-rich proteins that are active against herpes viruses. The sensor can detect histatins, anti-fungal proteins that are potent inhibitors of candida, which is normally kept in check at extremely low levels in the mouth. When the oral balance is upset, however, by HIV infection or other immunosuppressive and debilitating disorders, antifungal defenses are overwhelmed and candida flourishes uncontrolled.

[0117] The sensor **517** can also sense salivary constituents that thwart bacterial attack. These enzymes destroy the opposition by various mechanisms, including degrading bacterial membranes, inhibiting the growth and metabolism of certain bacteria, and disrupting vital bacterial enzyme systems.

[0118] The sensor **517** can provide data to the processor **519** that can detect symptoms of Alzheimer's disease, Sjögren's syndrome, cystic fibrosis, diabetes, and diseases of the adrenal cortex. The system can be deployed as sensors for systemic diseases, such as diabetes, arthritis, osteoporosis, HIV, cardiovascular disease (heart disease, stroke, high blood pressure), osteoporosis, obesity, blindness, kidney disease, and nervous system diseases. Additionally, the sensor **517** and the processor **519** can monitor levels of hormones and therapeutic medications—as well as the presence of illicit drugs.

[0119] In one embodiment, the sensor **517** with a tiny fluorescent dye molecule is placed on the appliance. The fluorescent molecule is sensitive to the presence of other molecules in its immediate environment. Thus, when the

target compound is recognized, the fluorescent molecule changes its light intensity. When light from the fluorescent molecule is imaged onto the face of a CCD detector, an electrical signal is produced. In general, fluorescence-based chemical sensing devices include three components: a light source that excites the sensing element, the sensing element that produces the fluorescence (usually a fluorescent dye that is used to tag the sample under investigation), and a photodetector that responds to the fluorescence of the sensor.

[0120] In another embodiment, the sensor 517 is a fiber optic sensor. A white light source excites the sensor element that is in contact with saliva. The output of the fiber is connected to a fiber optic spectrometer consisting of a grating placed in front of a CCD array. The spectral variation at the fiber output end due to the evanescent wave absorption phenomenon is then recorded as a measure of bacterial activity. Other mass spectrometry techniques can be used to detect saliva components.

[0121] In yet another embodiment, the sensor 517 can be enzyme-linked immunosorbent assays to distinguish a range of salivary components that are biomarkers for changes in the body's health. In yet other implementations, the sensor 517 can be a microfluidic system that can perform detection of multiple analytes in samples of saliva such as the system disclosed in U.S. Pat. No. 6,699,384, the content of which is incorporated by reference.

[0122] FIG. 7B shows a second embodiment that provides treatment in a closed-feedback loop accordance with a diagnosis. In this embodiment, an appliance 523 has a plurality of delivery nozzles 528A and 528B that project from the appliance to contact the patient's gum tissue. The nozzles 528A and 528B can be on either the frontal side, the lingual side, or both sides of the teeth on the jaw. Optionally, one or more reservoirs 529A and 529B can store extra drug/agent for delivery through nozzles 528A-528B. The processor 519 receives outputs from sensor(s) 517 and activates the nozzles 528A-528B accordingly to deliver drugs or therapeutic agents as needed.

[0123] In one embodiment, the appliance 523 includes a miniaturized closed-loop pumping system that will control its own dosing rate. The system can monitor glucose by monitoring sugar levels in saliva and can pump the right amount of drug such as insulin into the oral cavity for subsequent dispersal into the bloodstream. The insulin delivery pump senses the patient's blood glucose level and changes the dose of insulin accordingly. In one embodiment, the pump is an ink-jet based pump, while in another embodiment the pump is MEMS (Micro Electro Mechanical System) based and can change shape when electrically activated. Other MEMS based pump and sensor as known by those skilled in the art can be used as well. For instance, distributed MEMS electrostatic pumping devices of U.S. Pat. No. 6,485,273 can be used, while MEMS sensors as disclosed in U.S. Pat. No. 6,736,980 can measure various characteristics of fluid flow and filtration and may measure the temperature, flow rate, pressure, etc. of the fluid. The contents of both the '273 patent and the '980 are incorporated by reference herein.

[0124] The processor 519 can execute the following computer program in a closed-loop control of drug delivery:

[0125] Capture sensor data on dental appliance

[0126] If sensor data indicates drug level is below a predetermined level, increase pump drive to increase drug delivery.

[0127] If sensor data indicates drug level is above the predetermined level, stop or decrease pump drive to decrease drug delivery.

[0128] Each computer program is tangibly stored in a machine-readable storage media or device (e.g., program memory or magnetic disk) readable by a general or special purpose programmable computer, for configuring and controlling operation of a computer when the storage media or device is read by the computer to perform the procedures described herein. The inventive system may also be considered to be embodied in a computer-readable storage medium, configured with a computer program, where the storage medium so configured causes a computer to operate in a specific and predefined manner to perform the functions described herein.

[0129] Portions of the system and corresponding detailed description are presented in terms of software, or algorithms and symbolic representations of operations on data bits within a computer memory. These descriptions and representations are the ones by which those of ordinary skill in the art effectively convey the substance of their work to others of ordinary skill in the art. An algorithm, as the term is used here, and as it is used generally, is conceived to be a self-consistent sequence of steps leading to a desired result. The steps are those requiring physical manipulations of physical quantities. Usually, though not necessarily, these quantities take the form of optical, electrical, or magnetic signals capable of being stored, transferred, combined, compared, and otherwise manipulated. It has proven convenient at times, principally for reasons of common usage, to refer to these signals as bits, values, elements, symbols, characters, terms, numbers, or the like.

[0130] It should be borne in mind, however, that all of these and similar terms are to be associated with the appropriate physical quantities and are merely convenient labels applied to these quantities. Unless specifically stated otherwise, or as is apparent from the discussion, terms such as "processing" or "computing" or "calculating" or "determining" or "displaying" or the like, refer to the action and processes of a computer system, or similar electronic computing device, that manipulates and transforms data represented as physical, electronic quantities within the computer system's registers and memories into other data similarly represented as physical quantities within the computer system memories or registers or other such information storage, transmission or display devices.

[0131] The terms and expressions which have been employed in the foregoing specification are used therein as terms of description and not of limitation, and there is no intention, in the use of such terms and expressions, of excluding equivalents of the features shown and described or portions thereof, it being recognized that the scope of the invention is defined and limited only by the claims which follow. For example, although films or appliances have been disclosed as mechanisms for delivery drugs or substances,

droplets can be used to deliver substances to the patient as well. Typically, droplets can be sized within the range of about 1 to 200 microns and may be presented to the mucosa within a liquid, solid, or gaseous suspension, including an aerosol system which refers to a gaseous suspension of particles dispensed within the form of a mist. Other embodiments for delivering drugs or substances can be used as well. Whereas particular embodiments of the present invention have been described herein for purposes of illustration, it will be evident to those skilled in the art that numerous variations of the details may be made without departing from the invention as defined in the appended claims.

What is claimed is:

1. A method for intra-orally diagnosing a body condition, comprising:

attaching a sensor to an oral structure; and

sampling an intra-oral substance; and

detecting the body condition based on the intra-oral substance.

2. The method of claim 1, comprising

scanning a patient's dentition; and

designing a dental appliance coupleable to the sensor based on the scanned dentition.

3. The method of claim 1, wherein the body condition comprises a disease.

4. The method of claim 1, wherein the sensor senses a pathogen or a salivary component.

5. The method of claim 1, comprising detecting a presence or absence of one or more medical conditions and providing a diagnosis.

6. The method of claim 4, wherein the diagnosis is transmitted to a remote computer.

7. The method of claim 5, comprising transmitting by radio frequency or light frequency.

8. The method of claim 1, wherein the sensor senses an antimicrobial agent or a secretory antibody.

9. The method of claim 7, wherein the agent is formed in response to a pathogen.

10. The method of claim 8, wherein the pathogen includes one of: HIV, the fungus *Candida albicans*, and a bacteria associated with oral and systemic diseases.

11. The method of claim 1, wherein the sensor senses a salivary glycoprotein

12. The method of claim 1, wherein the sensor senses mucins, cystatins, or histatins.

13. The method of claim 1, wherein the sensor detects one of: Alzheimer's disease, Sjögren's syndrome, cystic fibrosis, diabetes, and diseases of the adrenal cortex.

14. The method of claim 1, wherein the sensor detects a systemic disease.

15. The method of claim 14, wherein the systemic disease comprises one of: diabetes, arthritis, osteoporosis, HIV, cardiovascular disease (heart disease, stroke, high blood pressure), osteoporosis, obesity, blindness, kidney disease, and nervous system diseases.

16. The method of claim 1, wherein the sensor monitors levels of hormones or therapeutic medications.

17. The method of claim 1, wherein the sensor detects an illicit drug.

18. The method of claim 1, wherein the sensor detects acidity.

19. The method of claim 1, wherein the sensor is a PH sensor.

20. The method of claim 1, comprising: fluidly providing a substance mounted on an oral structure into the body at a pre-selected dose.

* * * * *

专利名称(译)	用于口内诊断的系统和方法		
公开(公告)号	US20060116561A1	公开(公告)日	2006-06-01
申请号	US11/000433	申请日	2004-11-30
[标]申请(专利权)人(译)	TRICCA ROBERTê 吴本佳 李春华 KUO ERIC		
申请(专利权)人(译)	TRICCA ROBERTê 吴本佳 李淳化 KUO ERIC		
当前申请(专利权)人(译)	ALIGN科技股份有限公司.		
[标]发明人	TRICCA ROBERT E WU BENJAMIN M LI CHUNHUA KUO ERIC		
发明人	TRICCA, ROBERT E. WU, BENJAMIN M. LI, CHUNHUA KUO, ERIC		
IPC分类号	A61B5/00		
CPC分类号	A61B5/0088 A61B5/14532 A61B5/4547 A61B5/4839 A61B5/682 A61B10/0051		
其他公开文献	US7766658		
外部链接	Espacenet USPTO		

摘要(译)

公开了用于通过采样和测试口腔内流体来检测或诊断疾病的系统和方法。

