



(19) **United States**

(12) **Patent Application Publication**
Martin et al.

(10) **Pub. No.: US 2004/0036599 A1**

(43) **Pub. Date: Feb. 26, 2004**

(54) **POPULATION MONITORING SYSTEM**

Publication Classification

(76) Inventors: **Keith Llewellyn Martin**, Wiltshire (GB); **Christopher S. Cox**, Wiltshire (GB); **Peter Douglas Biggins**, Wiltshire (GB)

(51) **Int. Cl.⁷** **G08B 1/08**
(52) **U.S. Cl.** **340/539.11; 340/573.1; 600/301**

(57) **ABSTRACT**

Correspondence Address:

JOHN S. PRATT, ESQ
KILPATRICK STOCKTON, LLP
1100 PEACHTREE STREET
SUITE 2800
ATLANTA, GA 30309 (US)

A system for monitoring a live population uses a unit (1) as a local data collection means to derive data on the physical condition of a population member (2). The unit (1) has a local processor (6) for correlating and storing the physical condition data relative to time, and means (7) for transferring the stored data from the local processor (6) to a remote data collection means (3). The remote data collection means also receives data relating to the location of the population member (2) relative to time, and analyses the physical condition and location data for unusual events, providing a signal on the occurrence of an unusual event. The physical condition may be derived from a sensor (4), which is a non-invasive sensor for measuring pulse rate, temperature and oxygen levels. The location data is provided from a location means (5) incorporated in the unit (1).

(21) Appl. No.: **10/332,762**

(22) PCT Filed: **Jun. 1, 2001**

(86) PCT No.: **PCT/GB01/02450**

(30) **Foreign Application Priority Data**

Jun. 6, 2000 (GB) 0013610.1

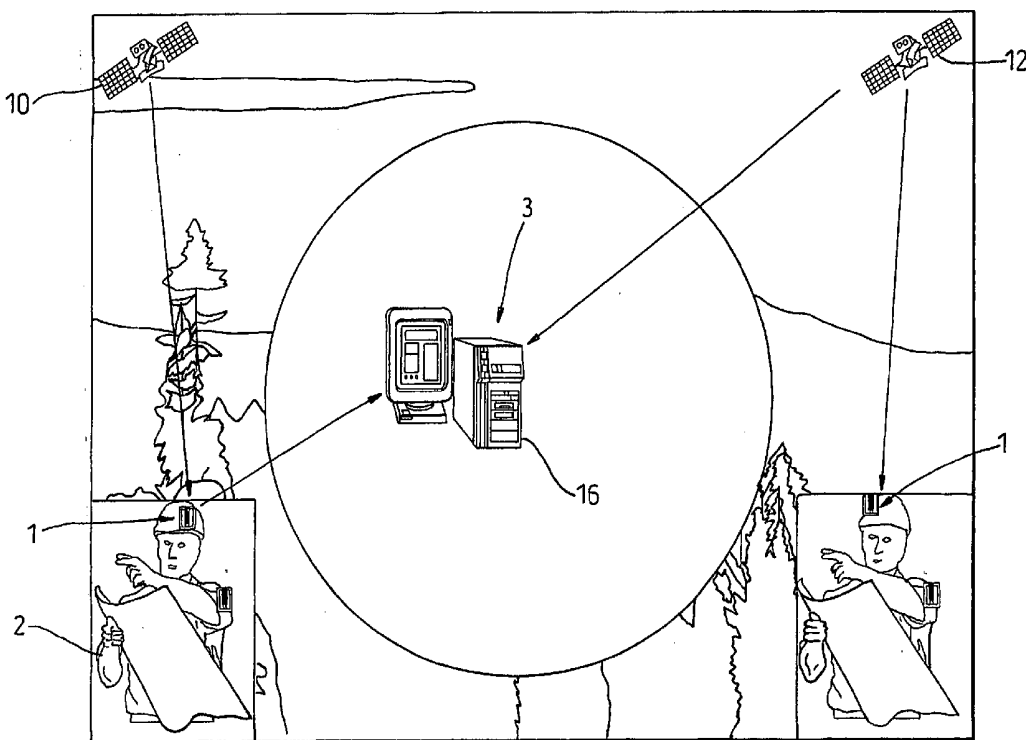

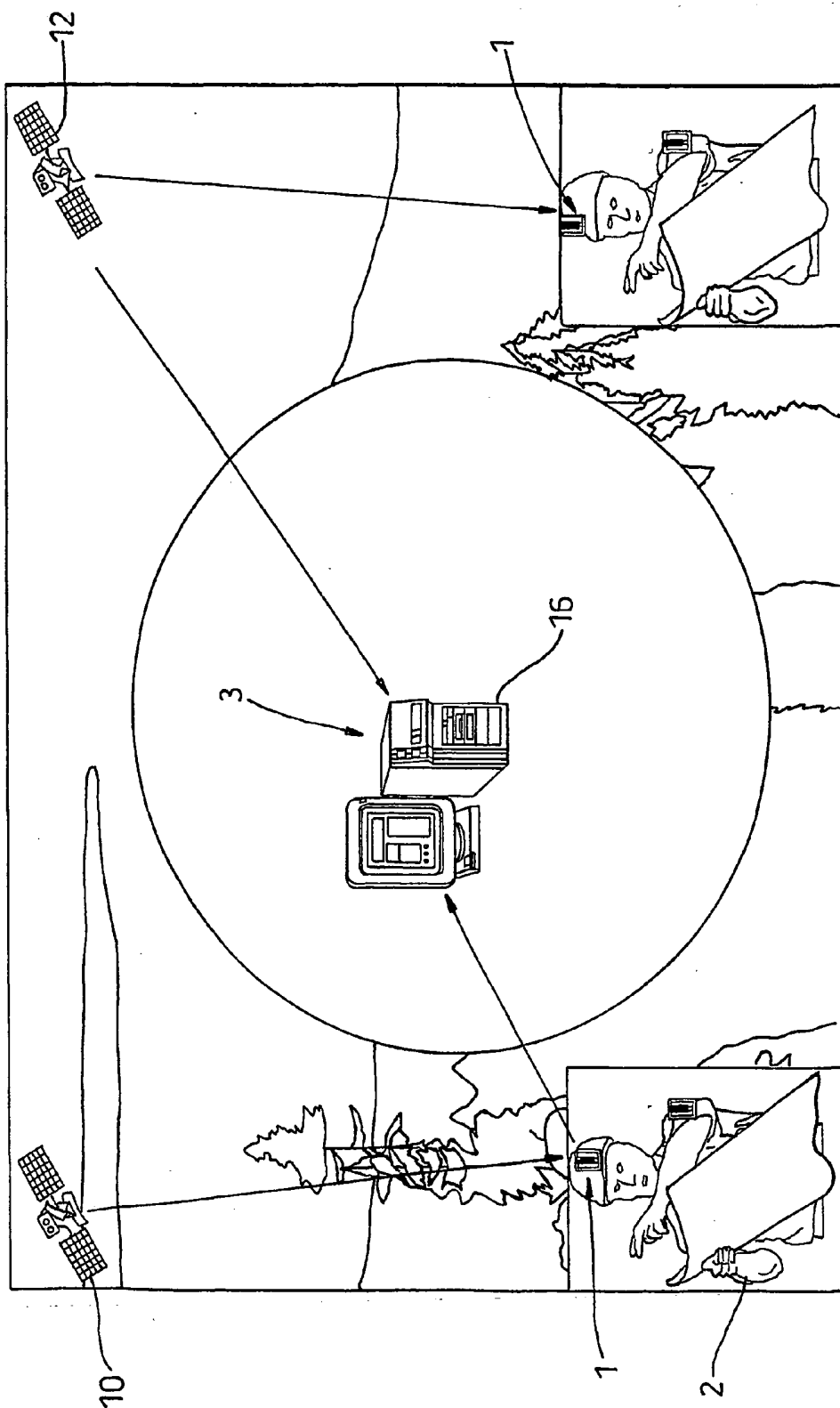

Fig. 1

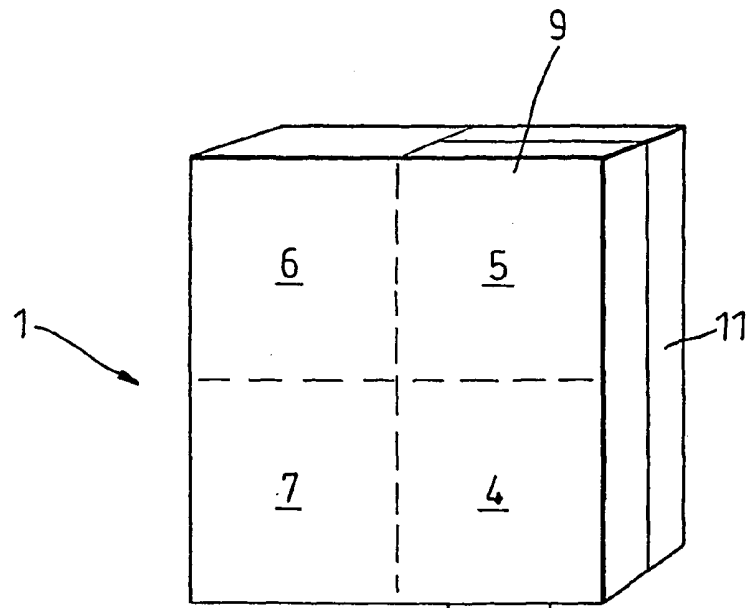

Fig. 2

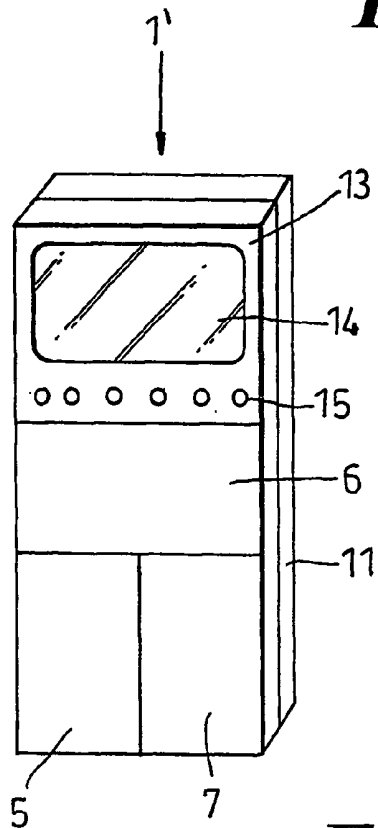

Fig. 3

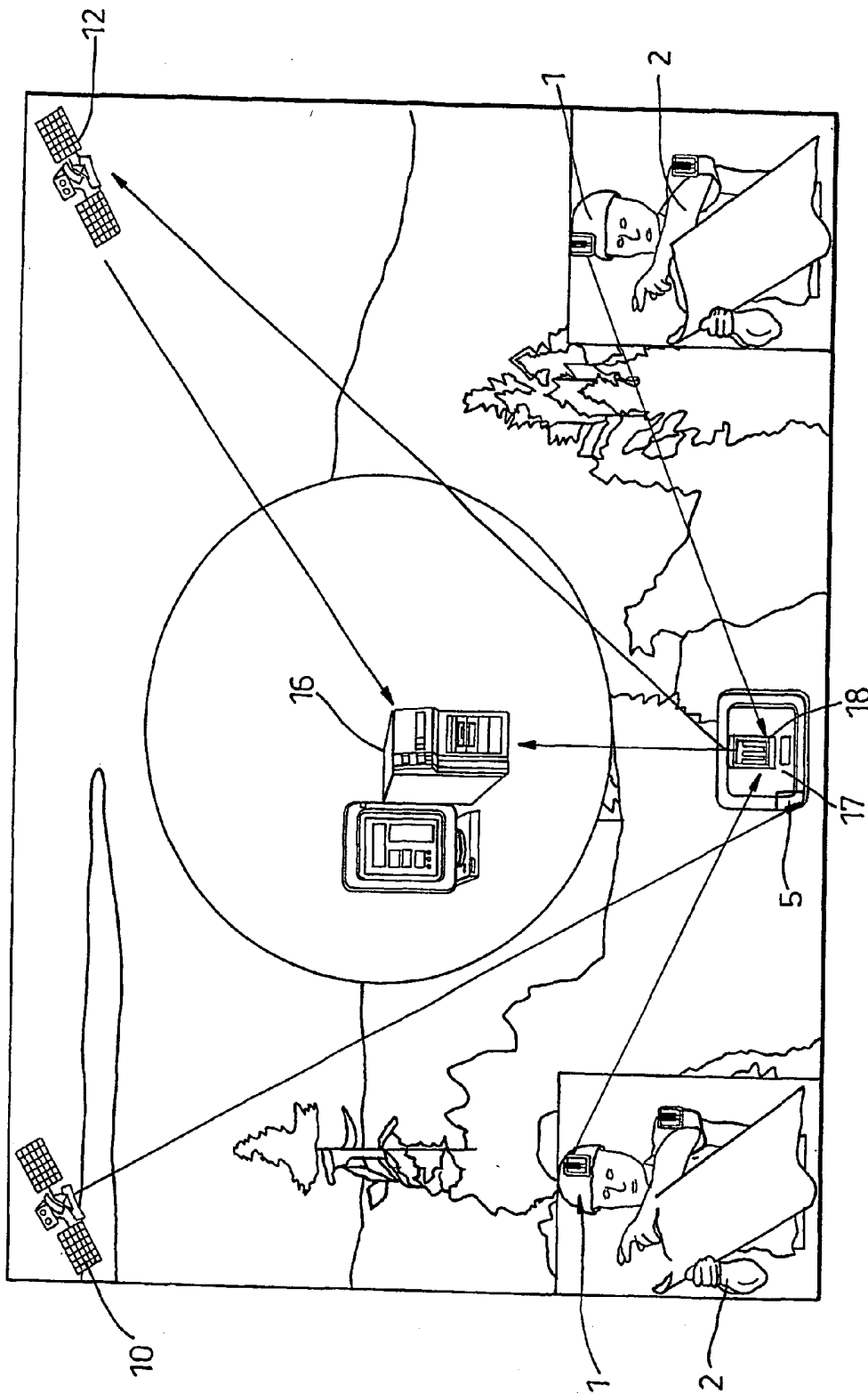

Fig. 4

POPULATION MONITORING SYSTEM

[0001] This invention relates to a system for monitoring a live population, with data from the population being transferred to a remote station for analysis.

[0002] There are various situations where there is a need for the monitoring over a period of time of the state of a live population (whether human, animal or plant) and the location of the population members. An example is where emergency service personnel are dealing with hazardous incidents. The monitoring is on the whole done by the personnel using radio or telephone communications to provide the necessary information to another human. The information provided can be analysed manually or from input to a computer, so that appropriate action can be triggered, for example in a medical emergency to provide appropriate help to the correct location. This system relies on a human initiating the communication in the first place, and may not provide accurate medical or location information. It is also difficult to correlate information from different sources to provide an overall picture of the incident, to enable hazards to be predicted.

[0003] According to the present invention, a system for monitoring a live population by monitoring at least one member of the population includes local data collection means operative to derive data relating to the physical condition of the population member, a local processor for correlating and storing the physical condition data relative to time, means for transferring the stored data from the local processor to a remote data collection means, the remote data collection means also accessing data relating to the location of the population member relative to time, and including a main processor for facilitating analysis of the physical condition and location data for identification of unusual events.

[0004] As the physical condition data and location data are correlated with time, these data can be provided accurately to the remote data collection means. The data can then be analysed for unusual events, if necessary in conjunction with data from other sources, to predict and signal the unusual events, enabling appropriate action to be taken. The monitoring system therefore performs more efficiently.

[0005] The live population may be a population of humans, animals or plants. The data relating to physical condition picks up abnormal physical symptoms, due to disease as such, injury or other factors such as environmental conditions. Analysis of this data can then be used to identify unusual events, in terms of disease, or environmental conditions.

[0006] The local data collection means and local processor are preferably incorporated in a unit. A single unit may derive data relating to physical condition from more than one population member, but it is preferred that each population member has their own unit. This enables easy monitoring of each population member separately.

[0007] The local data collection means then preferably comprises a sensor attached to the population member, and controlled by the local processor. The processor may operate the sensor continuously or intermittently. This is particularly useful where the population consists of animals or plants, but may also be useful for humans. As operation of the unit is automatic, there is no room for human error.

[0008] Alternatively, the local data collection means may comprise a manually-operable device, into which data relating to physical condition is input. Clearly, this can only be operated by humans, but is useful for deriving data from more than one population member.

[0009] Conveniently the means for transferring the stored data comprises telecommunication means, for sending radio signals or the like. A telecommunication means is preferably associated with each local data collection means. It is preferably incorporated in a unit with the local data collection means and the local processor, and is controlled by the local processor.

[0010] The operation of the local processor is preferably programmable. The telecommunication means may be operative to receive data to alter the programming of the local processor.

[0011] The unit preferably contains a power source such as batteries, operated under the control of the local processor.

[0012] Preferably the unit includes a location means operative to derive data relating to the location of the population member, and the local processor then correlates and stores the physical condition data and the location data relative to time. This provides particularly accurate physical condition and location data.

[0013] The local processor then controls operation of the location means as well, so that it is operated continuously or intermittently.

[0014] Alternatively the location means may be separate from the unit. The location means may transmit the location data to the remote data collection means. The unit may transmit the physical condition data to the remote data collection means via the location means. The location means may then correlate the physical condition and location data relative to time.

[0015] The remote data collection means may simply comprise a central computer station for receiving, storing and analysing the data. Alternatively it may comprise a central station and a number of intermediate stations which receive the data from one or more units, and relay it to the central station for storage and analysis. With this arrangement, the location means may be at the intermediate station, which correlates the location and physical condition data relative to time, and relays it to the central station. The data is preferably stored at the central station in a computer database.

[0016] The sensor for a human or animal may derive data relating to several states of the body, including pulse rate, temperature, oxyhaemoglobin, carboxyhaemoglobin and cytochrome oxidase. Monitoring is preferably by a non-invasive sensor. This may be of a near infra-red spectroscopy (NIRS) type or any other suitable type. Sensors for plants may derive data relating to temperature, water content and the like.

[0017] The location data is preferably derived from a global positioning satellite system.

[0018] Embodiments of the invention are illustrated, by way of example only, in the accompanying drawings, in which:—

[0019] FIG. 1 is a semi-diagrammatic illustration of a population monitoring system according to the invention;

[0020] FIG. 2 is a diagrammatic illustration of a unit used in FIG. 1;

[0021] FIG. 3 is similar to FIG. 2, but shows a modified unit; and

[0022] FIG. 4 is a semi-diagrammatic illustration of a modified monitoring system.

[0023] The population monitoring system of FIG. 1 has a unit 1 which derives data about the state of a population member 2 (in this case a human body), data being transferred from the unit 1 to a remote station 3 for analysis.

[0024] The unit 1 is shown in more detail in FIG. 2. It comprises a sensor 4 adapted to be attached to the body 2 to derive data relating to the physical condition of the body 2, a location means 5 which derives data relating to the location of the body 2, a local processor 6 for correlating and storing the physical data and location data relative to time, and telecommunication means 7 for transmitting the stored data to the remote station 3.

[0025] The sensor 4 is a non-invasive sensor of the near infra-red spectroscopy (NIRS) type. It has two sensor pads 8 adapted to be attached to the body 2 at spaced locations, such as the head and the arm. The sensor pads measure oxygen levels in the body 2, using near infra-red spectroscopy to monitor the levels of chromophores, whose absorbance is oxygen-dependent. Background interference from other tissues is compensated for by measuring changes in absorbance. The use of multiple wavelengths of light allows monitoring of changes in oxyhaemoglobin, carboxyhaemoglobin and cytochrome oxidase, which are all chemical states of the body relating to oxygenation levels and thus indicate the medical condition of the body 2. The sensor 4 also measures temperature and pulse data. The sensor pads 8 are non-invasively attached to the body 2 by detachable means such as tape or a band and by wires to the main part of the unit. The main part of the unit 1 is attached to the body 2 or the wearer's clothing. It can be made small and lightweight.

[0026] The main part of the unit 1 also houses the location means 5, comprising a global positioning monitor 9 which receives spatial co-ordinates from a satellite 10, as well as the time.

[0027] The data from the sensor 4 and the location means 5 is transmitted to the local processor 6, which correlates and stores it in relation to time, in a suitable electronic memory. The processor 6 is a programmable microprocessor unit adapted to operate the sensor and the location means as required. Thus, the sensor and location means may be operated continuously or intermittently. The unit 1 also includes a power source in the form of a battery 11, and the local processor 6 is also programmed to act as a power management system. Further the local processor 6 operates the telecommunication means 7 periodically to send the stored data to the remote station 3. The telecommunication means 7 sends the data by a radio signal, either directly or using a satellite 12 as a communications channel. The data could instead be transferred by telephone (terrestrial or satellite) or cable, or even manually.

[0028] FIG. 3 shows a modified unit 1' in which the sensor 4 is omitted, and the data relating to physical condition is instead derived by manual input by a human operator. Thus, the unit 1' has an input terminal 13 instead of the sensor 4 and pads 8. The terminal 13 has a screen 14 and keys 15. The processor 6 stores a number of physical conditions, one or more of which are chosen by the operator to input to the processor 6. Thus unit 1' may also be used to derive data for more than one population member. The details of the individual population members are also held by the processor 6, so that the data is related to the individuals. The construction and operation of the unit 1 is otherwise the same as that of the unit 1 of FIG. 2.

[0029] The remote station 3 comprises a data collection computer 16 including a database in which the data is stored for analysis. The computer includes a main processor for analysing the physical condition and location data for unusual events and providing a signal on the occurrence of an unusual event. The computer 16 may also have access to other, collateral, data, to assist in the identification of unusual events. The other data may be meteorological, geographic, pollution, medical or demographic databases.

[0030] The analysis of unusual events is based on the data from the units 1 or 1' and the collateral databases, chosen as required according to the expected events. The analysis uses a set of rules describing the signature of an event as a departure from a normal background level of one or more parameters. The rules assign relative significance values to the events, to enable their significance to be evaluated singly and in combination, particularly where they arise from different databases. The rules assign an overall significance value, as a probability that an unusual event has occurred. The rules may vary according to the parameters used.

[0031] An example which is useful in practice is the analysis of disease events from medical data, time, location and meteorological data. One such analysis of a particular infectious disease has been carried out retrospectively. The rules looked at the occurrence of the disease as a function of time, location (by postal area in UK) and the meteorological record.

[0032] A first rule looked at the number of cases of the disease in relation to time and meteorological conditions, to predict the number of cases which would occur in a given future time period. The rule was modified if the predicted number of cases varied significantly from the actual number.

[0033] A second rule looked at the location of the cases, that is the spatial distribution in the postal areas. An infectious disease is expected to form clusters of cases, and the degree of clustering can be used to test the randomness of the spatial distribution to determine a departure from the expected distribution.

[0034] A third rule looked for a correlation between the spatial distribution of the cases and the prevailing wind, at a given time. The rule was modified according to any correlation.

[0035] Several instances of unusual events (for example, the disease becoming epidemic) were detected by the three rules.

[0036] The monitoring system has also been used with the unit 1' of FIG. 3, to test the analysis in real time, based on

manual input of physical condition, location data and meteorological data, to detect unusual events in environmental conditions, as at a hazardous incident. Here an unusual event may occur when the physical condition of several population members in a given case changes, and danger can be predicted. This enables evasive action to be taken by the individuals concerned.

[0037] Thus, the monitoring system can be used for populations, to signal unusual events. While it has been described in terms of monitoring a population of humans it would also be used to monitor populations of animals or even plants. When monitoring plants, data relating to location will be input to, or otherwise available to the central data collection computer 15, as global positioning will not be a requirement.

[0038] FIG. 4 shows a modified monitoring system particularly suitable for monitoring groups of population members in a given area, and corresponding reference numerals have been applied to corresponding parts. In FIG. 4, the location means 5 are provided not on the units 1, but at an intermediate or base station 17. The unit 1 therefore derives only physical conditions data, which the processor 6 correlates and stores relative to time. The processor 6 in this case provides the time information. The intermediate station serves to derive data on the location from the global positioning system. It has communication means 18 for receiving the physical condition data from the units 1, and relaying this, together with the location data, to the central data collection computer 15 for analysis. The physical condition and location data may be correlated by the intermediate station or the central computer 16. The communication means 18 preferably relays the data by a radio signal, but the data could be transferred by any suitable means.

1. A system for monitoring a live population by monitoring at least two members (2) of the population includes local data collection means (1) operative to derive data relating to the physical condition of each population member, a local processor (6) for correlating and storing the physical condition data relative to time, means (7) for transferring the stored data from the local processor (6) to a remote data collection means (3), the remote data collection means also accessing data relating to the location of each population member (2) relative to time, and including a main processor (15) for analysing the physical condition and location data for identification of unusual events in the population.

2. A system as claimed in claim 1, characterised in that the local data collection means and the local processor (6) are incorporated in a unit (1).

3. A system as claimed in claim 2, characterised in that a single unit (1) derives data relating to physical condition from more than one population member (2).

4. A system as claimed in claim 2, characterised in that each population member (2) has a separate unit (1).

5. A system as claimed in any of claims 2 to 4, characterised in that the local data collection means comprises a sensor (4) attached to the population member and controlled by the local processor (6).

6. A system as claimed in claim 5, characterised in that the local processor (6) operates the sensor (4) continuously.

7. A system as claimed in claim 5, characterised in that the local processor (6) operates the sensor (4) intermittently.

8. A system as claimed in any of claims 1 to 4, characterised in that the local data collection means comprises a manually-operable device (13) into which data relating to physical condition is input.

9. A system as claimed in any preceding claim, characterised in that the means for transferring the stored data comprises telecommunication means (7).

10. A system as claimed in claim 9, characterised in that a telecommunication means (7) is associated with each local data collection means.

11. A system as claimed in claim 10, characterised in that a telecommunication means (7) is incorporated in a unit (1) with the local data collection means and the local processor (6) for control by the local processor (6).

12. A system as claimed in any preceding claim, in which the local processor is programmable.

13. A system as claimed in claim 12, characterised in that the telecommunication means (7) is operative to receive data to alter the programming of the local processor.

14. A system as claimed in any preceding claim, characterised in that the unit (1) includes a power source (11) operated under the control of the local processor (6).

15. A system as claimed in any preceding claim, characterised in that the unit (1) includes a location means (5) operative to derive data relating to the location of the population member, and the local processor (6) correlates and stores the physical condition data and the location data relative to time.

16. A system as claimed in claim 15, characterised in that the local processor (6) controls operation of the location means (5).

17. A system as claimed in claim 16, characterised in that the local processor (6) operates the location means (5) continuously.

18. A system as claimed in claim 16, characterised in that the local processor (6) operates the location means (5) intermittently.

19. A system as claimed in any of claims 1 to 14, characterised in that a location means (17) operative to derive data relating to the location of the population member is separate from the unit (1).

20. A system as claimed in claim 19, characterised in that the location means (17) transmits the location data to the remote data collection means (3).

21. A system as claimed in claim 19 or claim 20, characterised in that the unit (1) transmits the physical condition data to the remote data collection means (3) via the location means (17).

22. A system as claimed in any preceding claim, characterised in that the remote data collection means comprises a central computer station (15) for receiving, storing and analysing the data.

23. A system as claimed in any of claims 1 to 21, characterised in that the remote data collection means comprises a central computer station (15) and a number of intermediate stations (16) which receive the data from one or more units (1), and relay it to the central station for storage and analysis.

24. A system as claimed in claim 23, characterised in that each intermediate station (16) includes a location means, which transmits the location data to the central station.

25. A system as claimed in any of claims 5 to 7, characterised in that the sensor (4) derives data relating to any or all of pulse rate, temperature and oxygen levels in a human or animal body.

26. A system as claimed in claim 25, characterised in that the sensor (4) is a non-invasive sensor.

27. A system as claimed in any preceding claim, characterised in that the location data is derived from a global positioning system (10).

28. A system as claimed in claim 9, characterised in that the telecommunication means (7) sends data by a radio signal.

* * * * *

专利名称(译)	人口监测系统		
公开(公告)号	US20040036599A1	公开(公告)日	2004-02-26
申请号	US10/332762	申请日	2001-06-01
[标]申请(专利权)人(译)	MARTIN KEITH LLEWELLYN COX Christopher S制作 BIGGINS PETER DOUGLAS		
申请(专利权)人(译)	MARTIN KEITH LLEWELLYN COX CHRISTOPHER S. BIGGINS PETER DOUGLAS		
当前申请(专利权)人(译)	国务秘书国防部 ,		
[标]发明人	MARTIN KEITH LLEWELLYN COX CHRISTOPHER S BIGGINS PETER DOUGLAS		
发明人	MARTIN, KEITH LLEWELLYN COX, CHRISTOPHER S. BIGGINS, PETER DOUGLAS		
IPC分类号	A61B5/00 G08B1/08		
CPC分类号	A61B5/1112 A61B5/002 A61B5/0022 G06F19/3493 A61B2560/0242 A61B2560/0462 A61B5/6814 G16H50/80		
优先权	2000013610 2000-06-06 GB		
其他公开文献	US7427920		
外部链接	Espacenet USPTO		

摘要(译)

用于监视活人口的系统使用单元 (1) 作为本地数据收集装置来导出关于人口成员 (2) 的身体状况的数据。单元 (1) 具有用于关联和存储相对于时间的物理条件数据的本地处理器 (6)，以及用于将存储的数据从本地处理器 (6) 传送到远程数据收集装置 (3) 的装置 (7)。。远程数据收集装置还接收与人口成员 (2) 相对于时间的位置有关的数据，并分析异常事件的物理状况和位置数据，提供关于异常事件发生的信号。物理条件可以从传感器 (4) 导出，传感器 (4) 是用于测量脉冲速率，温度和氧气水平的非侵入式传感器。位置数据由结合在单元 (1) 中的定位装置 (5) 提供。

