



US010213164B2

(12) **United States Patent**  
**Garudadri et al.**

(10) **Patent No.:** **US 10,213,164 B2**  
(45) **Date of Patent:** **Feb. 26, 2019**

(54) **METHOD AND APPARATUS FOR UNDER-SAMPLED ACQUISITION AND TRANSMISSION OF PHOTOPLETHYSMOGRAPH (PPG) DATA AND RECONSTRUCTION OF FULL BAND PPG DATA AT THE RECEIVER**

(75) Inventors: **Harinath Garudadri**, San Diego, CA (US); **Pawan Kumar Baheti**, San Diego, CA (US)

(73) Assignee: **QUALCOMM Incorporated**, San Diego, CA (US)

(\* ) Notice: Subject to any disclaimer, the term of this patent is extended or adjusted under 35 U.S.C. 154(b) by 1449 days.

(21) Appl. No.: **12/512,480**

(22) Filed: **Jul. 30, 2009**

(65) **Prior Publication Data**

US 2010/0082302 A1 Apr. 1, 2010

**Related U.S. Application Data**

(60) Provisional application No. 61/101,056, filed on Sep. 29, 2008, provisional application No. 61/100,654, filed on Sep. 26, 2008.

(51) **Int. Cl.**  
**H04B 1/00** (2006.01)  
**A61B 5/00** (2006.01)  
(Continued)

(52) **U.S. Cl.**  
CPC ..... **A61B 5/7232** (2013.01); **A61B 5/0006** (2013.01); **A61B 5/0024** (2013.01);  
(Continued)

(58) **Field of Classification Search**  
CPC .. G01R 13/0272; A61B 5/0024; A61B 5/7232  
(Continued)

(56) **References Cited**

U.S. PATENT DOCUMENTS

5,749,366 A 5/1998 Odagiri et al.  
5,961,577 A \* 10/1999 Soenen ..... G06F 7/588  
708/251

(Continued)

FOREIGN PATENT DOCUMENTS

CN 1550204 A 12/2004  
EP 0733340 A1 9/1996

(Continued)

OTHER PUBLICATIONS

Candes E J et al: "An Introduction to Compressive Sampling [A sensing/sampling paradigm that goes against the common knowledge in data acquisition]" IEEE Signal Processing Magazine, IEEE Service Center, Piscataway, NJ, US, vol. 24, No. 2, Mar. 1, 2008 (Mar. 1, 2008), pp. 21-30, XP011206127.

(Continued)

*Primary Examiner* — Michael P Nghiem  
(74) *Attorney, Agent, or Firm* — Kilpatrick Townsend & Stockton

(57) **ABSTRACT**

Certain aspects of the present disclosure relate to a method for compressed sensing (CS). The CS is a signal processing concept wherein significantly fewer sensor measurements than that suggested by Shannon/Nyquist sampling theorem can be used to recover signals with arbitrarily fine resolution. In this disclosure, the CS framework is applied for sensor signal processing in order to support low power robust sensors and reliable communication in Body Area Networks (BANs) for healthcare and fitness applications.

**33 Claims, 31 Drawing Sheets**

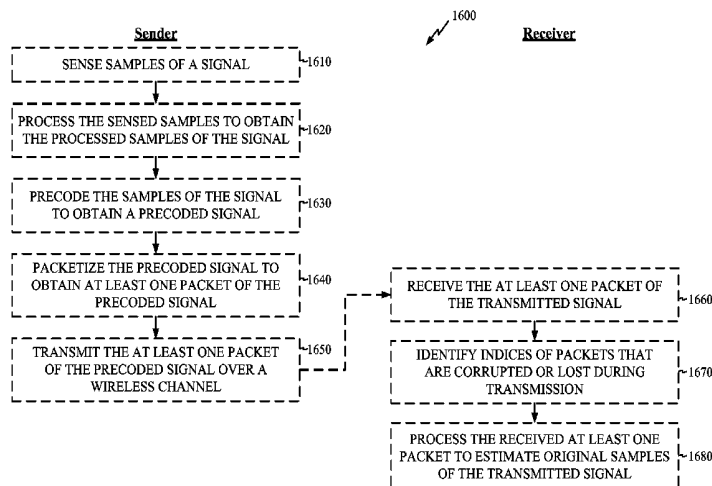

- (51) **Int. Cl.**  
**G01R 13/02** (2006.01)  
**A61B 5/1455** (2006.01)  
**G06K 9/00** (2006.01)  
**H03M 7/30** (2006.01)  
**A61B 5/021** (2006.01)
- (52) **U.S. Cl.**  
 CPC ..... **A61B 5/14551** (2013.01); **G01R 13/0272**  
 (2013.01); **G06K 9/00496** (2013.01); **H03M**  
**7/30** (2013.01); **A61B 5/021** (2013.01); **A61B**  
**2560/0209** (2013.01)
- (58) **Field of Classification Search**  
 USPC ..... 702/189  
 See application file for complete search history.

(56) **References Cited**

U.S. PATENT DOCUMENTS

7,018,338	B2 *	3/2006	Vetter et al.	600/503
2004/0106164	A1 *	6/2004	Brown	B82Y 15/00 435/14
2004/0213407	A1 *	10/2004	Fujita et al.	380/46
2005/0027207	A1	2/2005	Westbrook et al.	
2005/0164160	A1 *	7/2005	Gunter et al.	435/4
2005/0198505	A1 *	9/2005	Smith	713/168
2005/0280454	A1 *	12/2005	Szajnowski	G04F 10/06 327/156
2007/0081578	A1 *	4/2007	Fudge et al.	375/130
2007/0112545	A1 *	5/2007	Barford	G01D 21/00 702/191
2007/0159321	A1	7/2007	Ogata et al.	
2008/0104163	A1 *	5/2008	Barford	G06F 17/141 708/620
2008/0228446	A1 *	9/2008	Baraniuk et al.	702/189
2009/0048785	A1 *	2/2009	Katzir	G06K 9/00134 702/20
2009/0109919	A1 *	4/2009	Bertrand et al.	370/330
2009/0122319	A1 *	5/2009	Ronnekleiv et al.	356/477
2009/0190689	A1 *	7/2009	Blu et al.	375/285
2010/0008243	A1 *	1/2010	Viswanath et al.	370/252
2010/0182950	A1 *	7/2010	Sexton	H03M 7/30 370/328
2010/0220823	A1 *	9/2010	Biyani	H04B 3/32 375/346
2011/0025870	A1 *	2/2011	Baraniuk et al.	348/222.1

FOREIGN PATENT DOCUMENTS

EP	1297784	A1	4/2003
JP	2005518238	A	6/2005
JP	2007075372	A	3/2007
JP	2007184754	A	7/2007
WO	03071941	A1	9/2003
WO	WO2010003672		1/2010

OTHER PUBLICATIONS

International Preliminary Report on Patentability—PCT/US2009/058383, The International Bureau of WIPO—Geneva, Switzerland, dated Jan. 17, 2011.

International Search Report & Written Opinion—PCT/US09/058383—International Search Authority—European Patent Office—dated May 20, 2010.

Jason Laska et al; “Random Sampling for Analog-to-information Conversion of Wideband Signals” Design, Applications, Integration and Software, 2006 IEEE Dallas/CAS W Orkshop on, IEEE, PI, Oct. 1, 2006 (Oct. 1, 2006), pp. 119-122, XP031052636.

Mario A T Figueiredo et al: “Gradient Projection for Sparse Reconstruction: Application to Compressed Sensing and Other Inverse Problems” IEEE Journal of Selected Topics in Signal Processing, IEEE, US, vol. 1, No. 4, Dec. 1, 2007 (Dec. 1, 2007), pp. 586-597, XP011199163.

Pfetsch S et al: “On the feasibility of hardware implementation of sub-Nyquist random-sampling based analog-to-information conversion” Circuits and Systems, 2008. ISCAS 2008. IEEE International Symposium on, IEEE, Piscataway, NJ, USA, May 18, 2008 (May 18, 2008), pp. 1480-1483, XP031392264.

Baheti P. K., et al., “An Ultra Low Power Pulse Oximeter Sensor Based on Compressed Sensing” Wearable and Implantable Body Sensor Networks, 2009. BSN 2009. Sixth International Workshop on, IEEE, Piscataway, NJ, USA, Jun. 3, 2009 (Jun. 3, 2009), pp. 144-148, XP031522335.

Malioutov, D.M., et al., “Compressed Sensing With Sequential Observations”, 2008 IEEE International Conference on Acoustics, Speech and Signal Processing, Mar. 31, 2008, pp. 3357-3360.

Taiwan Search Report—TW098132585—TIPO—dated Oct. 26, 2012.

\* cited by examiner

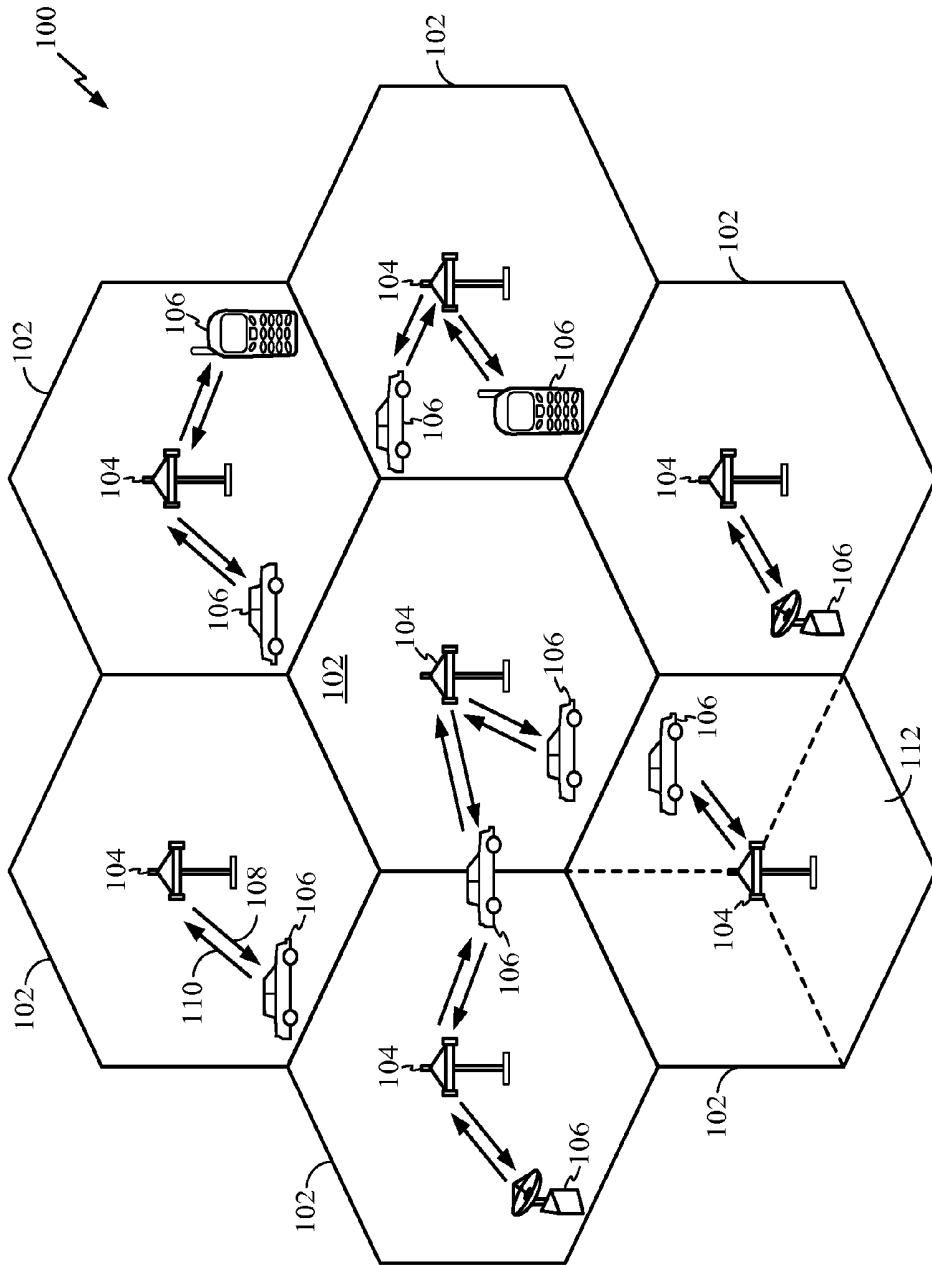

FIG. 1

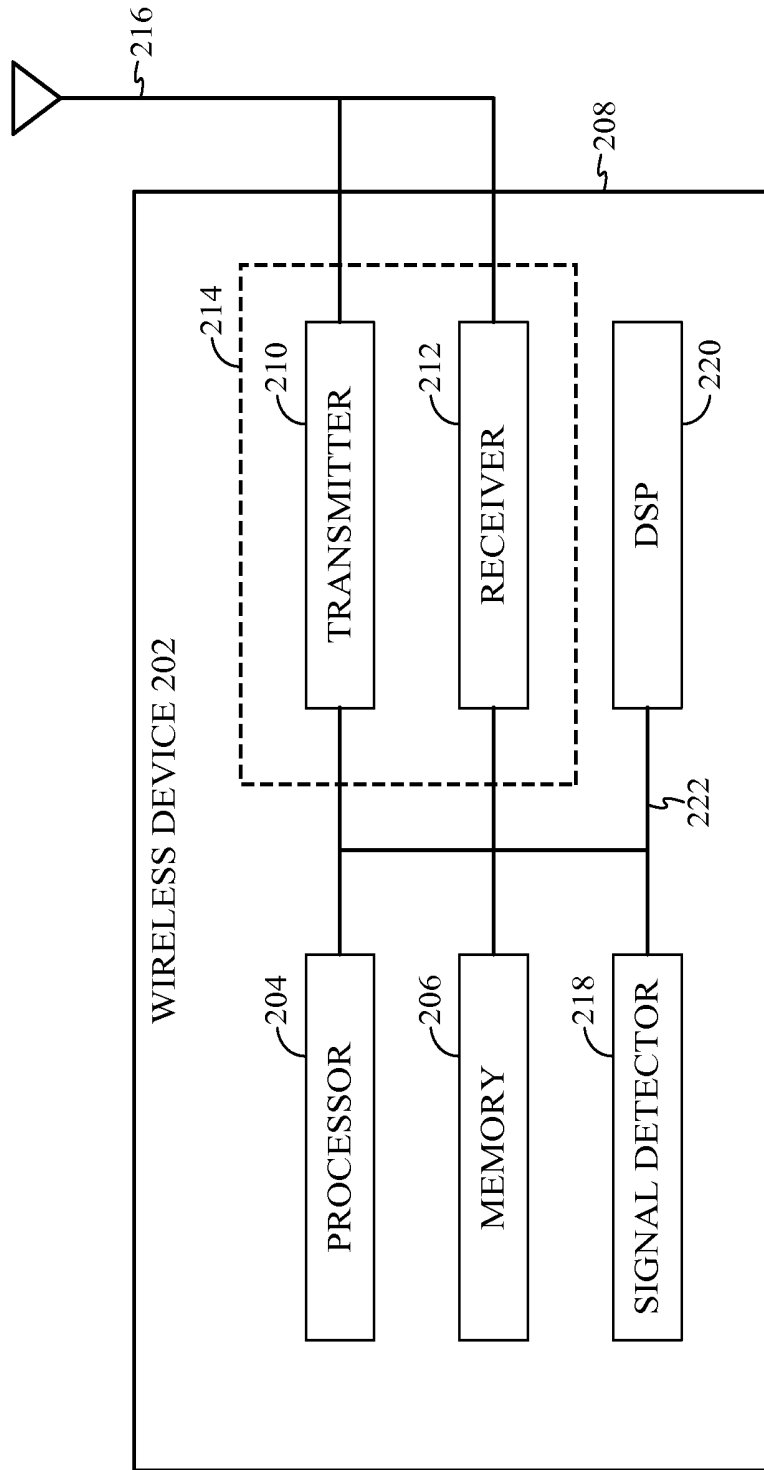

FIG. 2

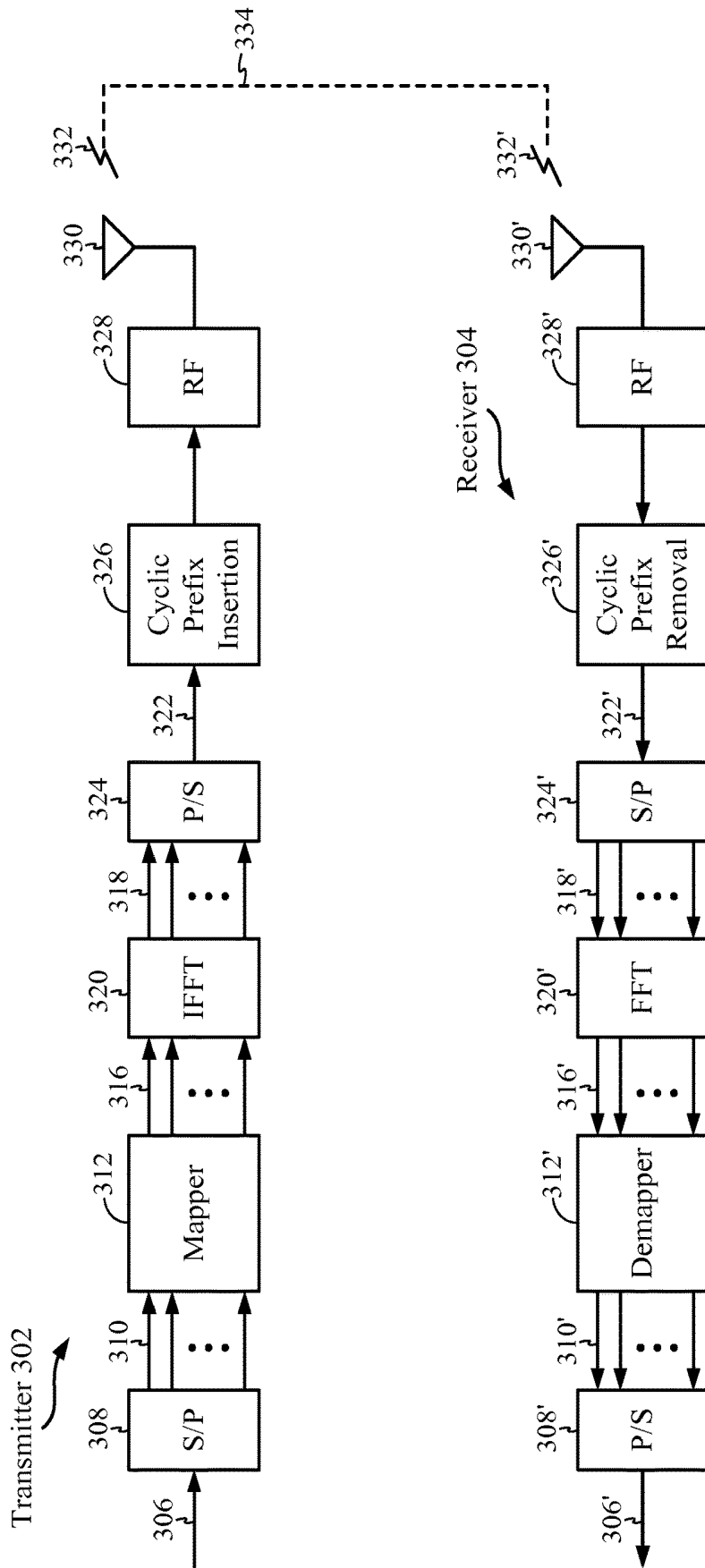

FIG. 3

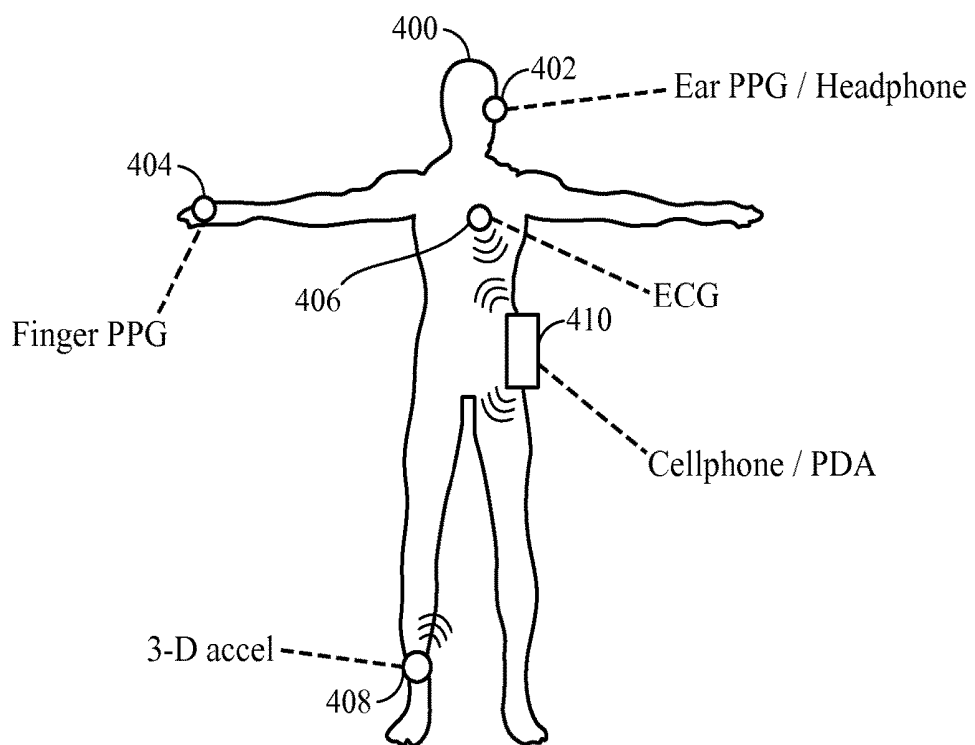

FIG. 4

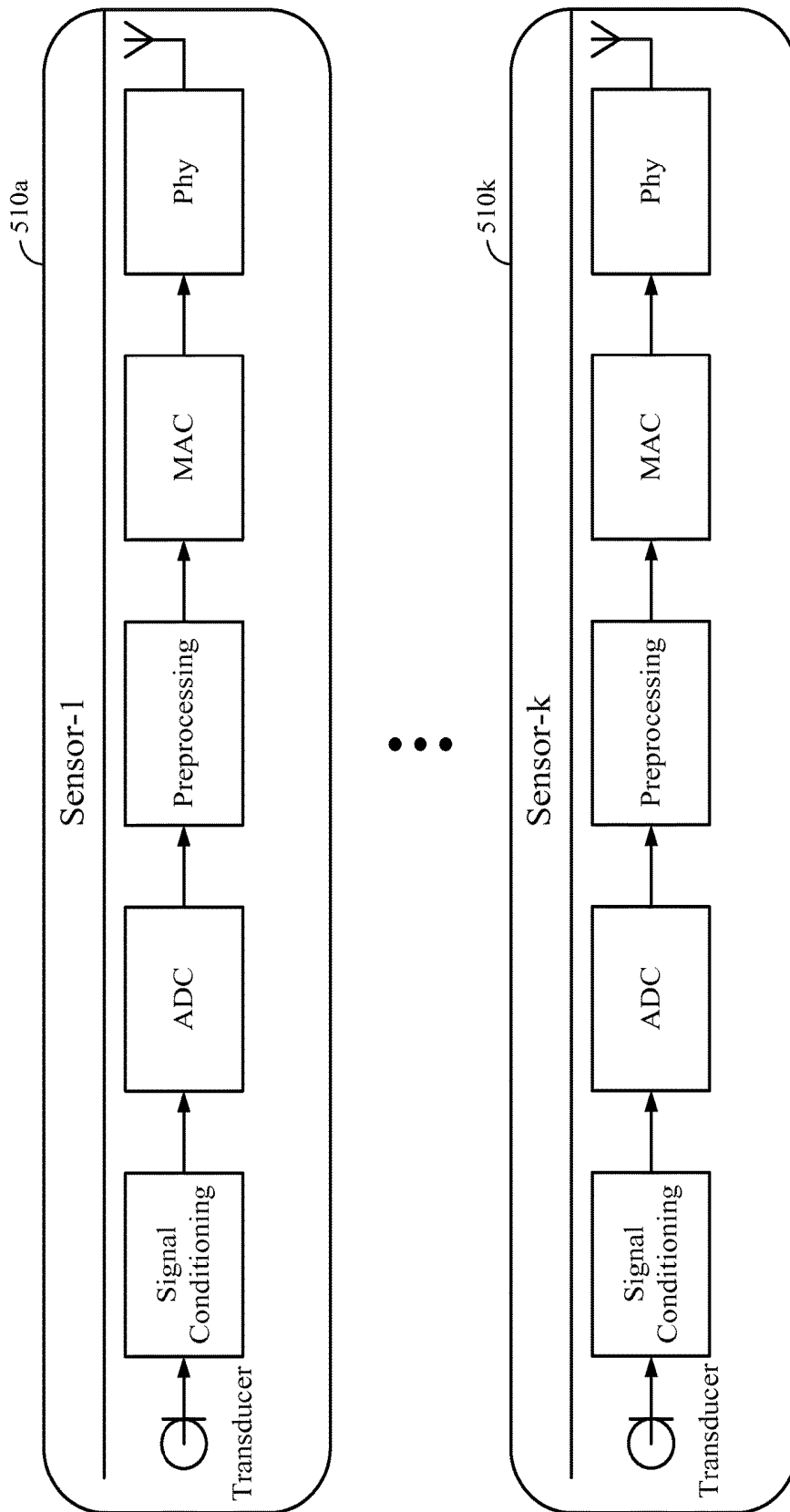

FIG. 5

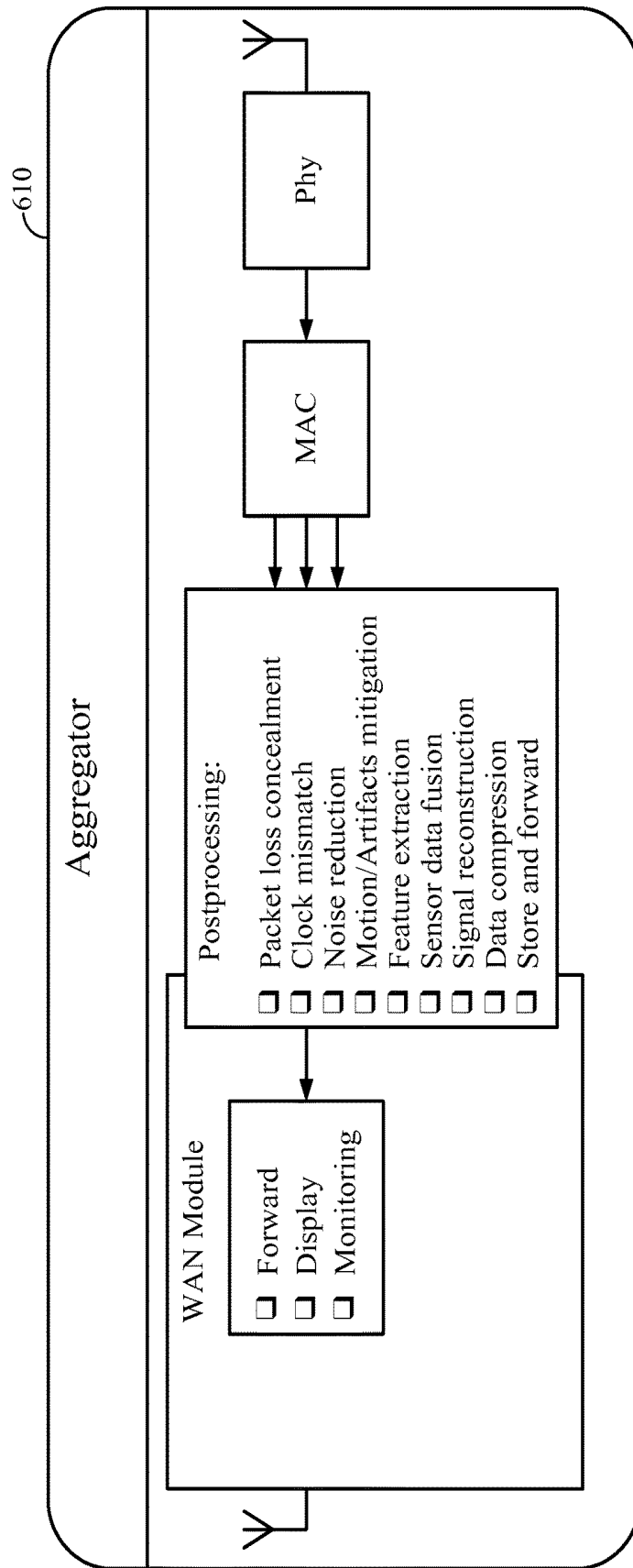

FIG. 6

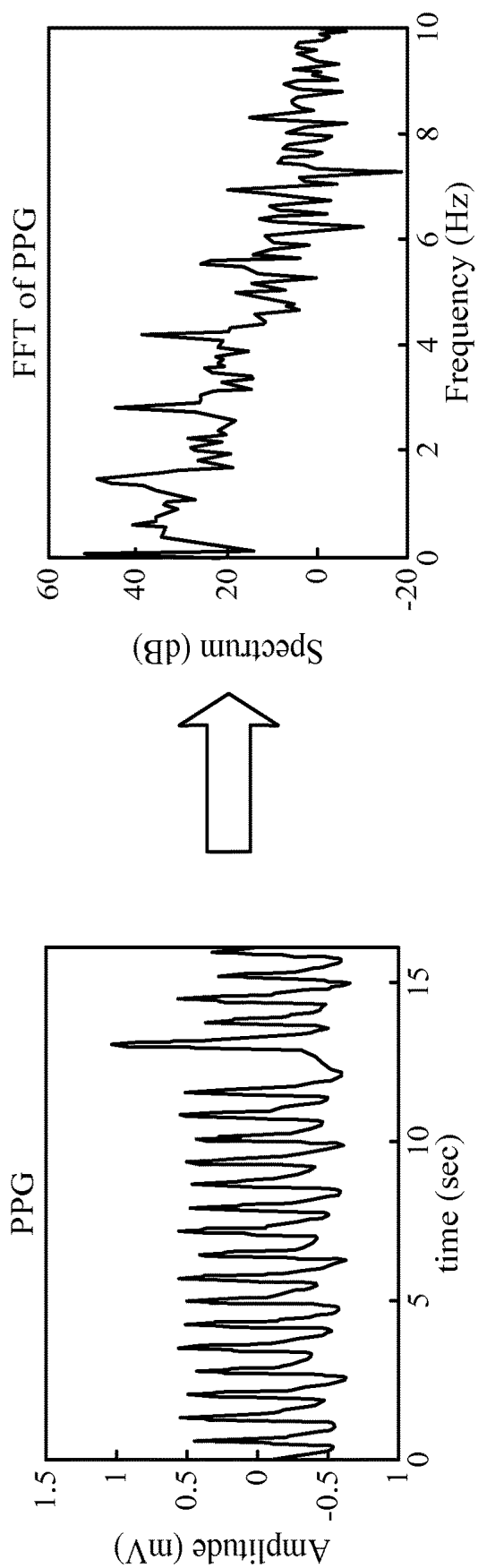

FIG. 7

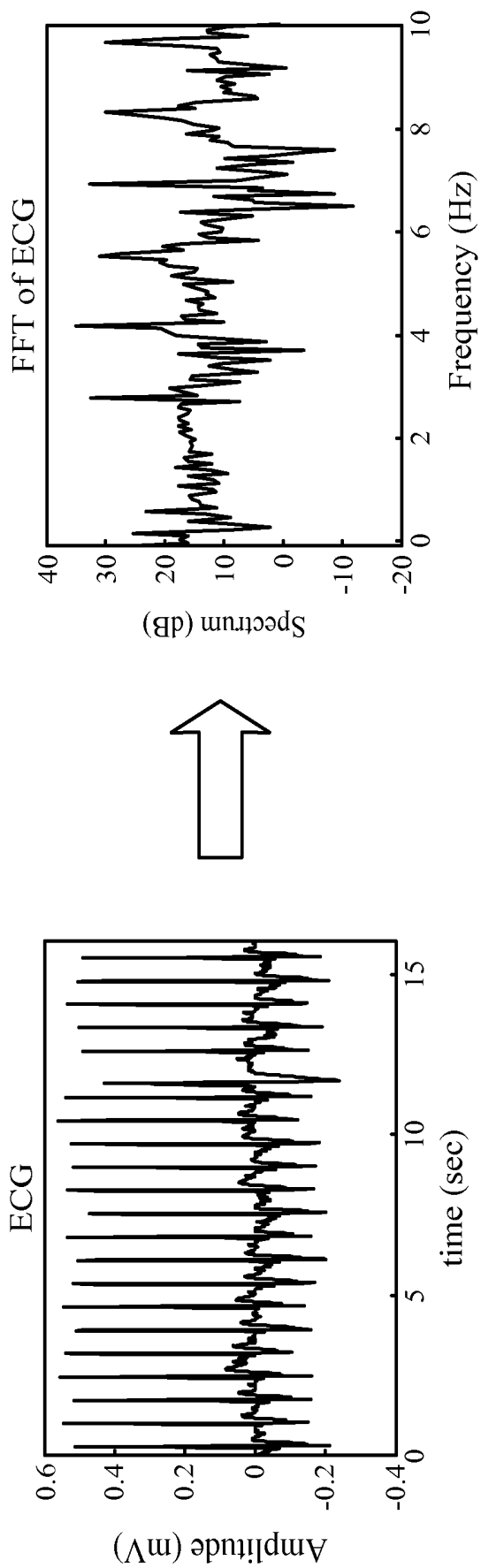

FIG. 8

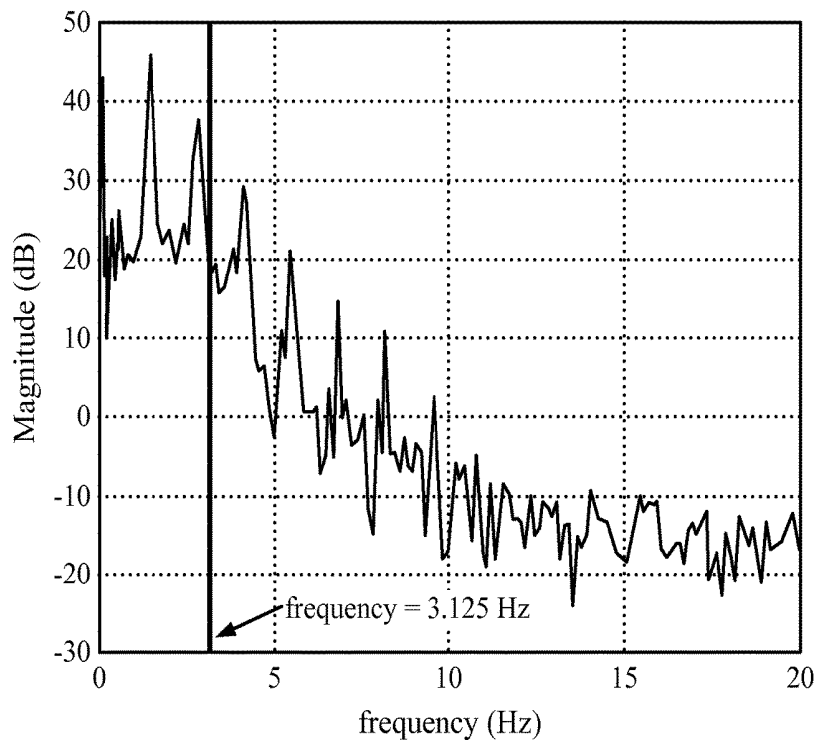
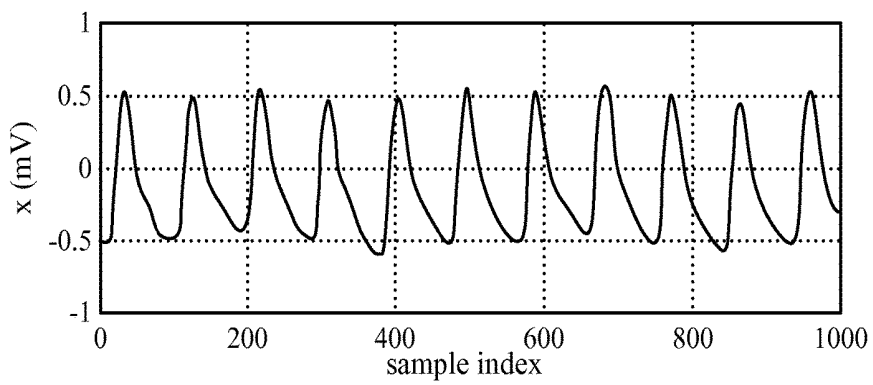
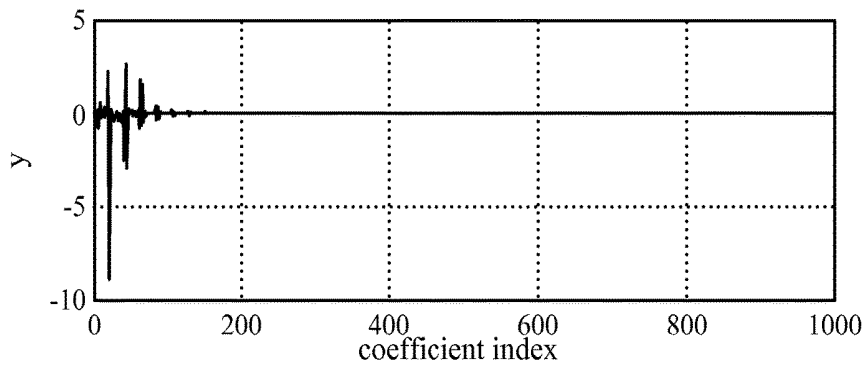

FIG. 9



(a)



(b)

FIG. 10

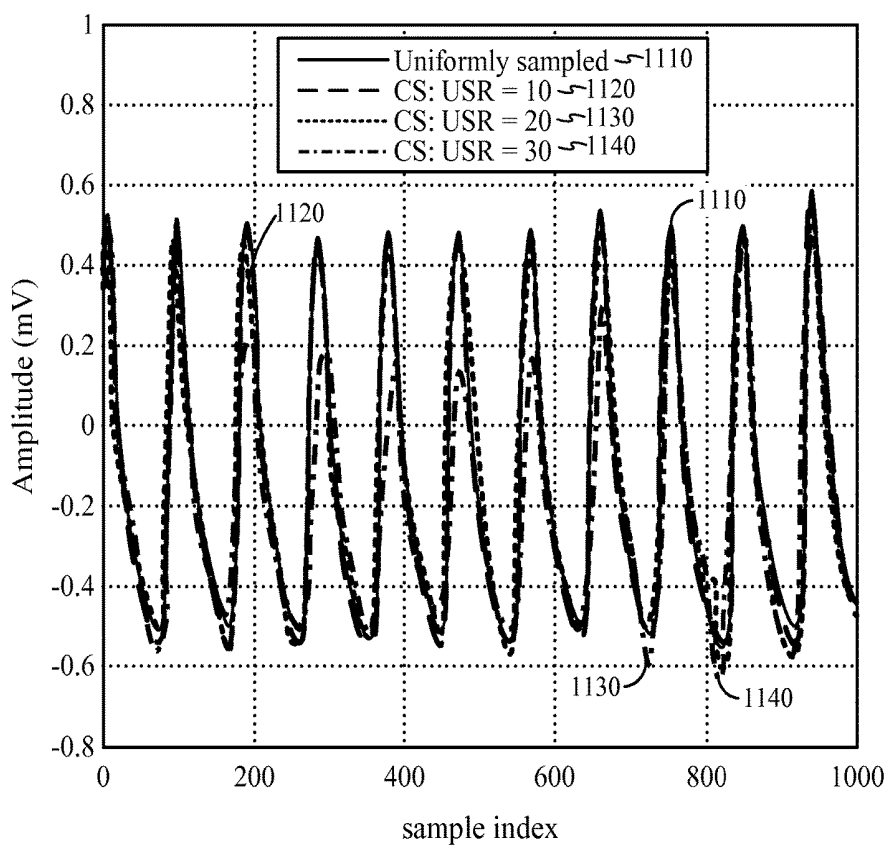

FIG. 11

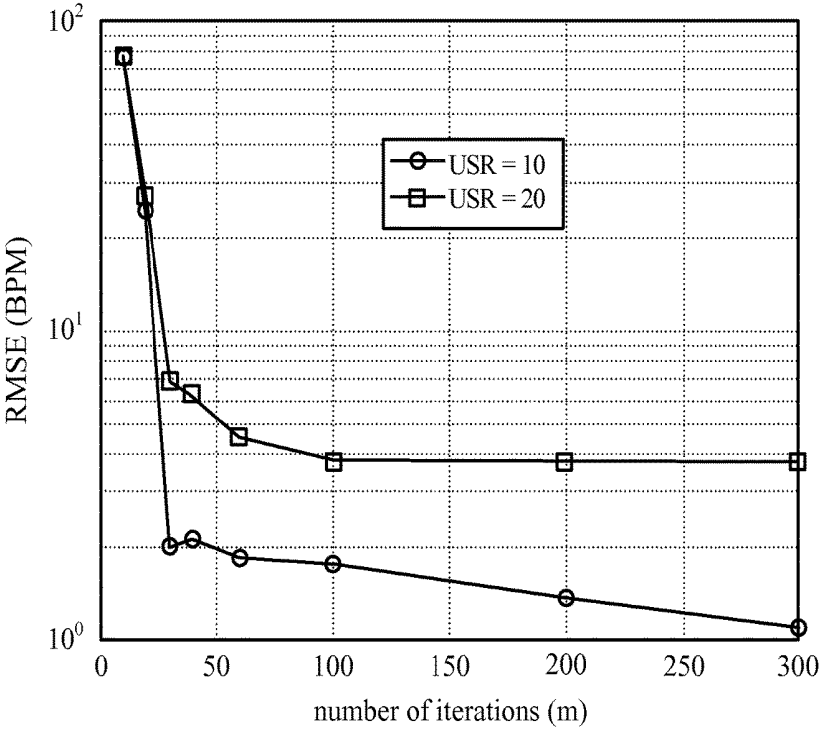

FIG. 12

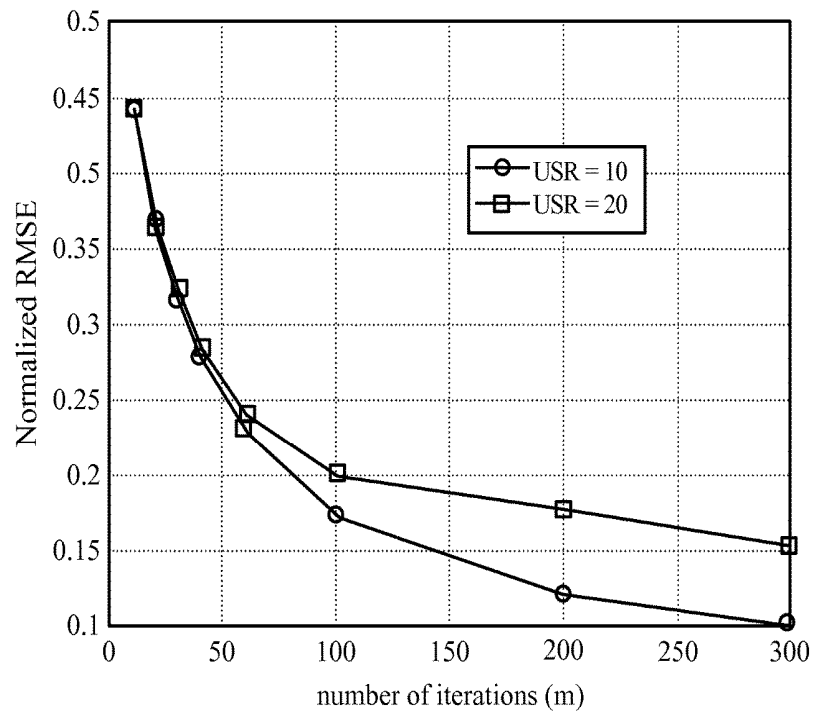

FIG. 13

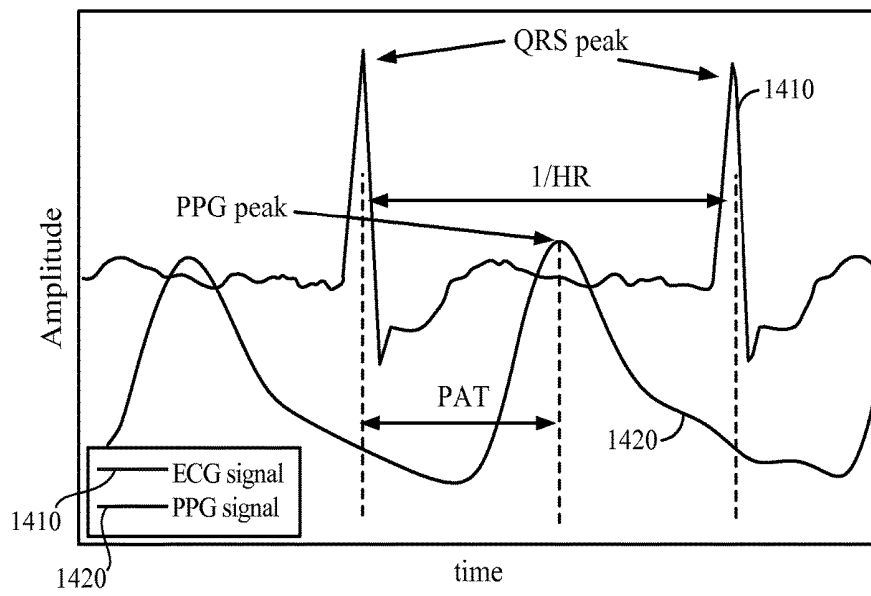

FIG. 14

Patient	Nyquist-PPG			CS-PPG (USR=40)		
	SBP (mmHg)	DBP (mmHg)	$N_{BP}$	SBP (mmHg)	DBP (mmHg)	$N_{BP}$
55	4.72	3.1	48.8	2.95	2.19	13.05
212	4.02	3.12	75.6	3.97	1.93	13
213	4.54	2.27	21.44	5.54	2.18	3.3
219	7.68	3.65	29.8	8.85	3.14	6.88
221	8.24	3.85	81.5	6.67	4.03	10.4
224	6.47	4.87	63.05	6.1	3.84	12.35
230	6.42	3.3	37.8	6.09	3.68	1.52
237	9.25	6.83	18.61	7.89	3.62	5.52
408	8.99	9.06	73.41	8.46	6.66	12.4
443	11.42	7.75	86.93	7.45	3.97	5.73
444	7.85	4.08	59.23	7.49	4.02	13.1
476	8.92	5.5	49.96	7.06	2.49	15.02
482	7.34	2.97	16.92	6.1	2.35	2.83
<b>Avg:</b>	<b>7.37</b>	<b>4.64</b>	<b>51</b>	<b>6.51</b>	<b>3.39</b>	<b>8.85</b>

FIG. 15

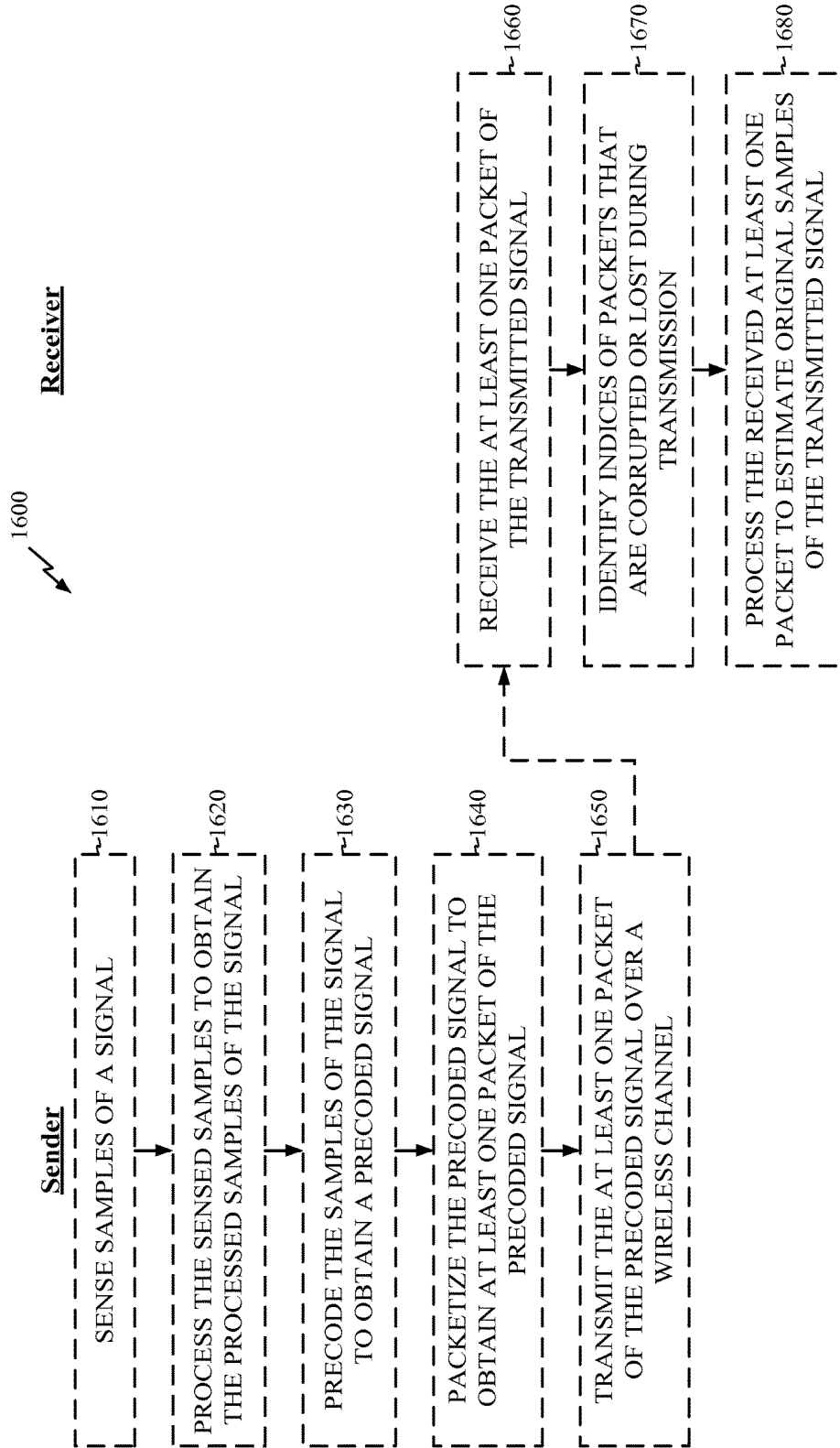

FIG. 16

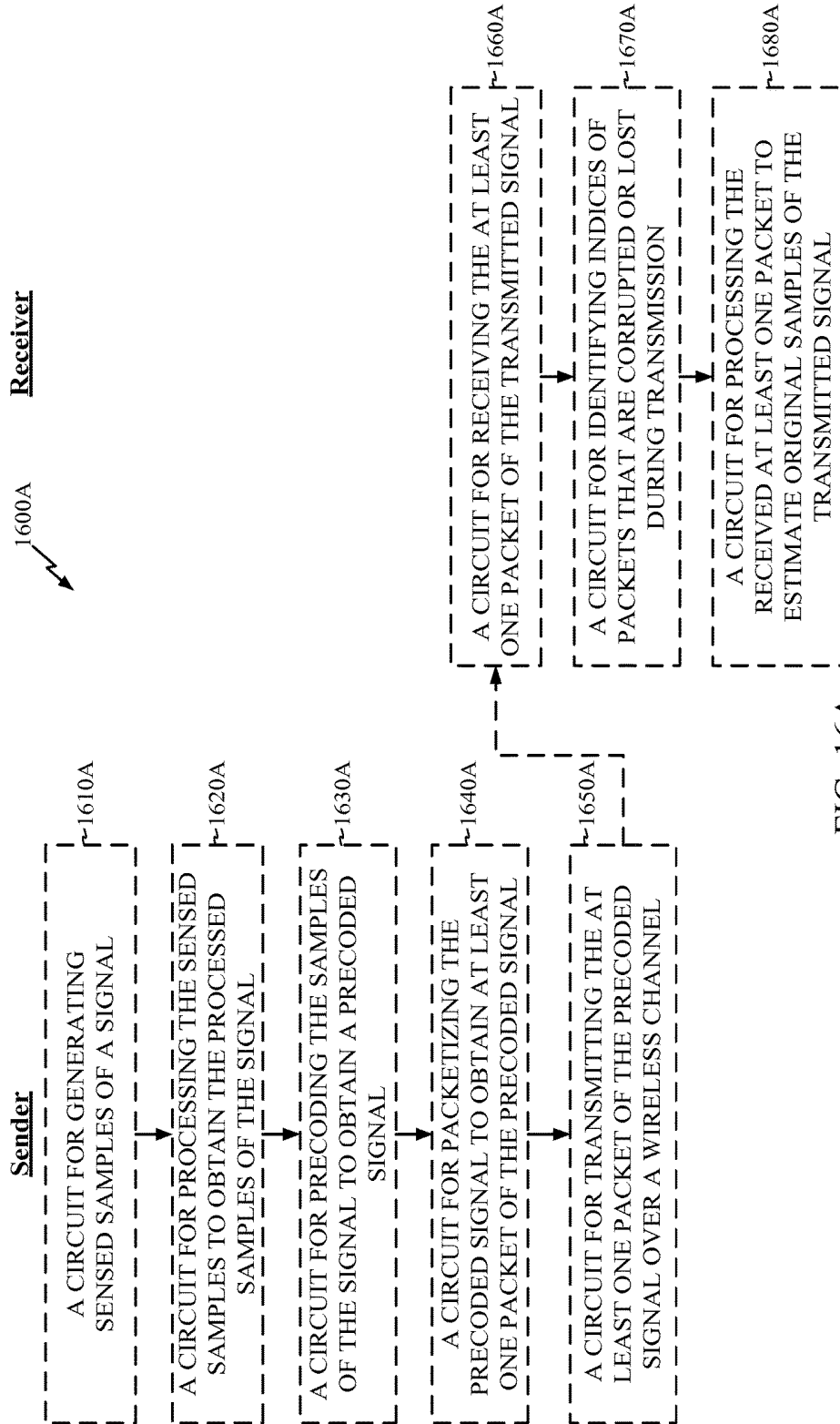

FIG. 16A

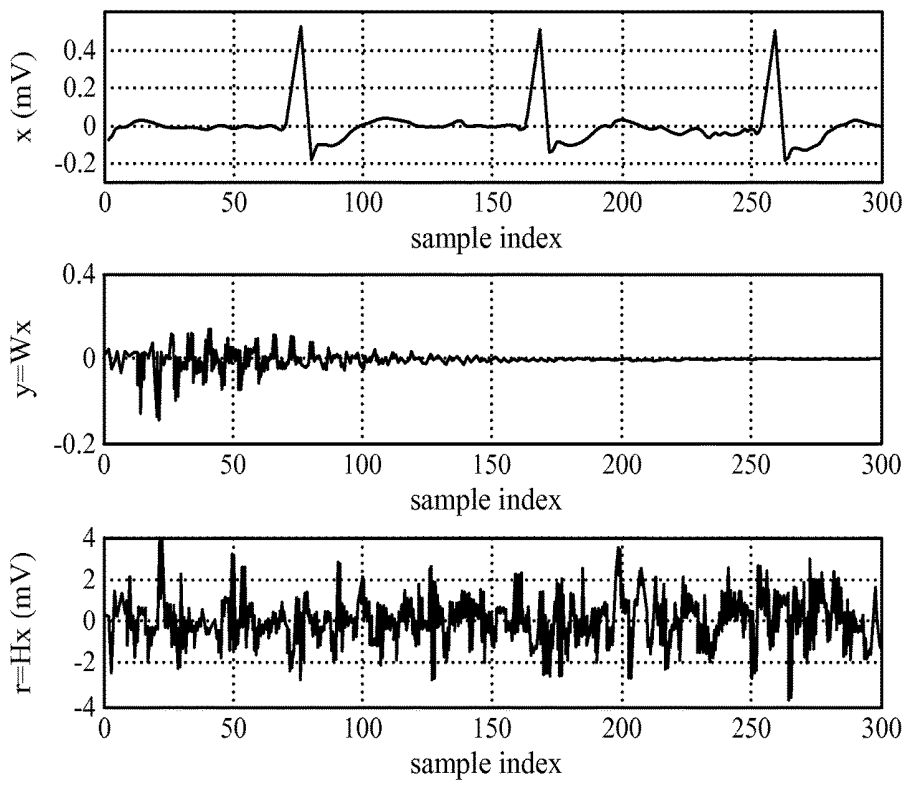

FIG. 17

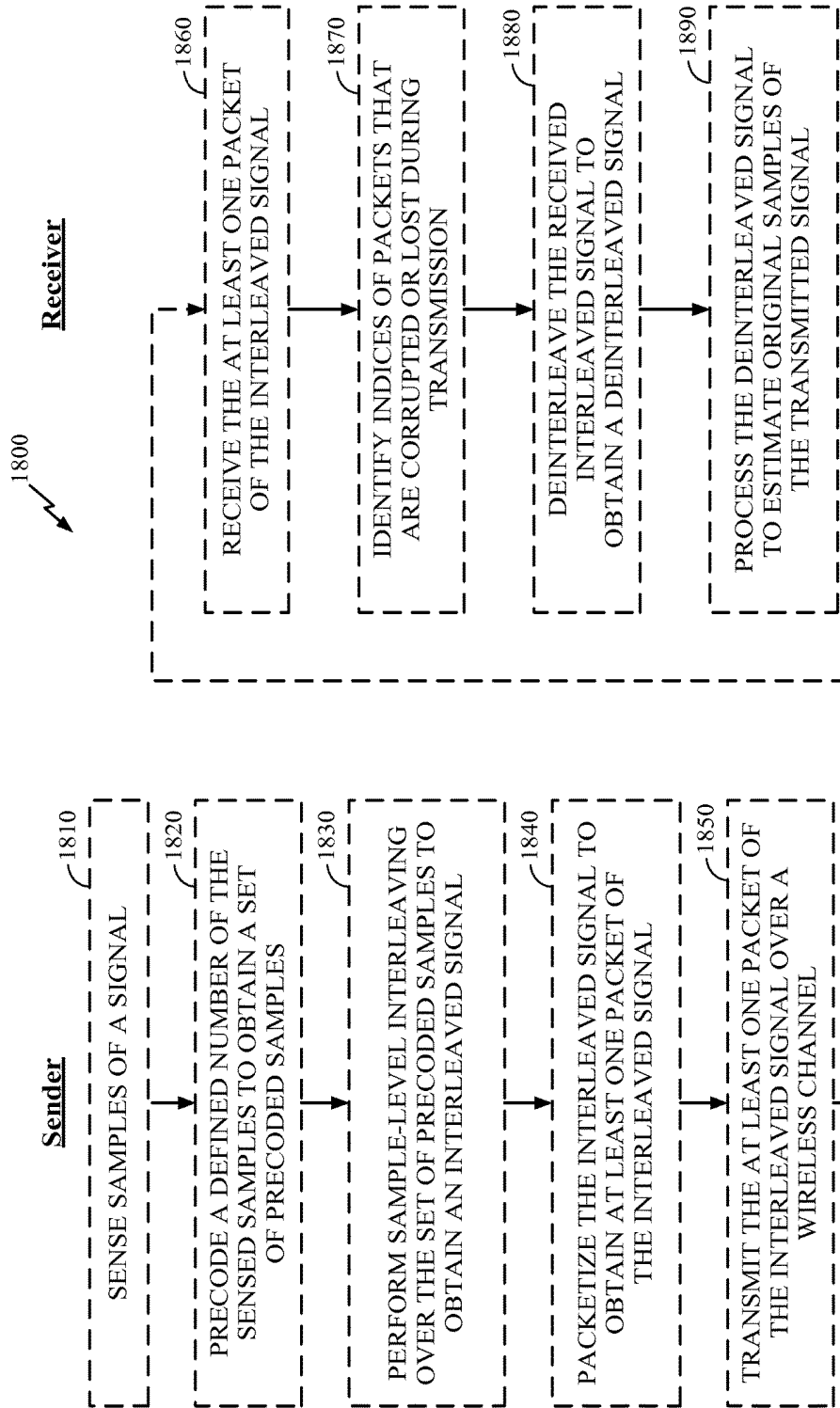

FIG. 18

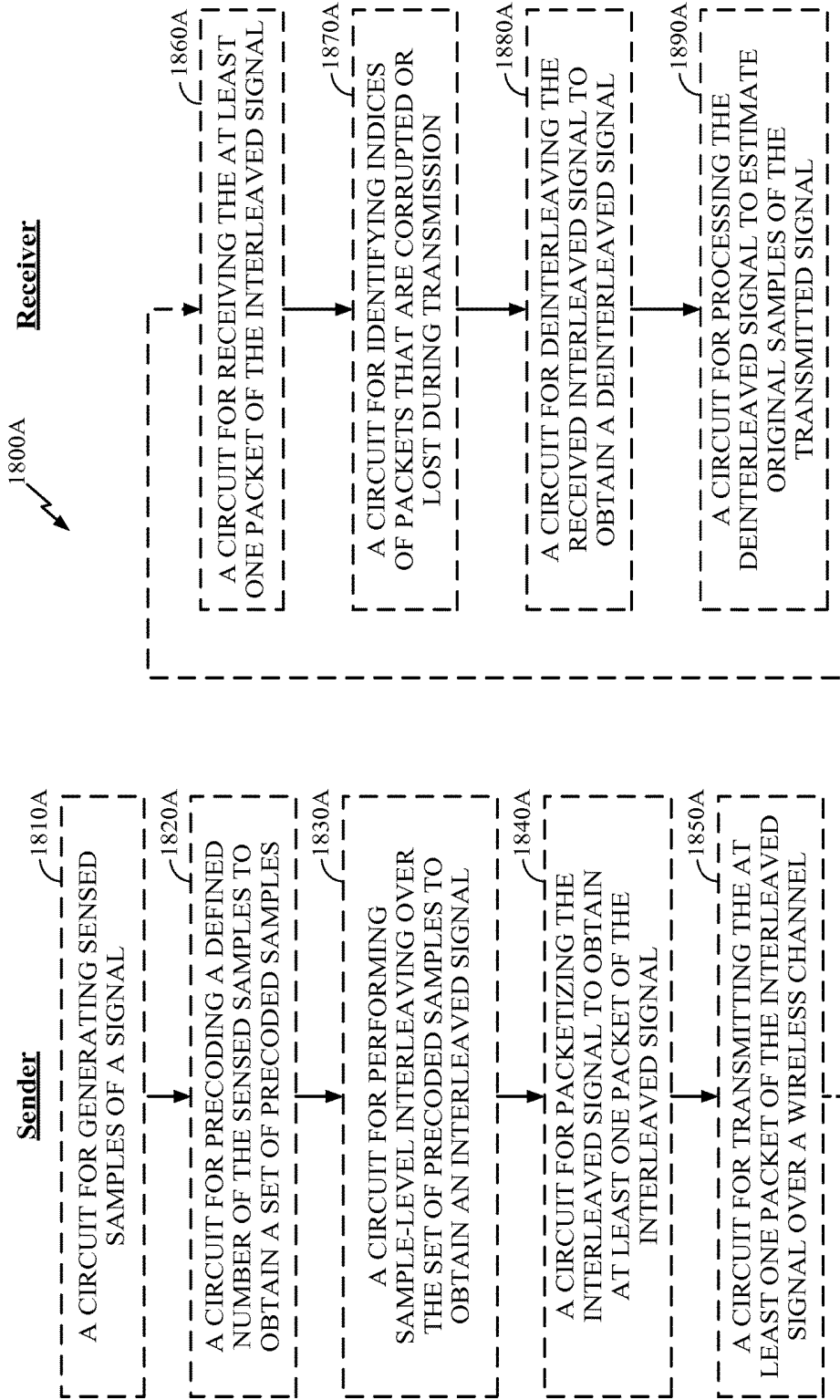

FIG. 18A

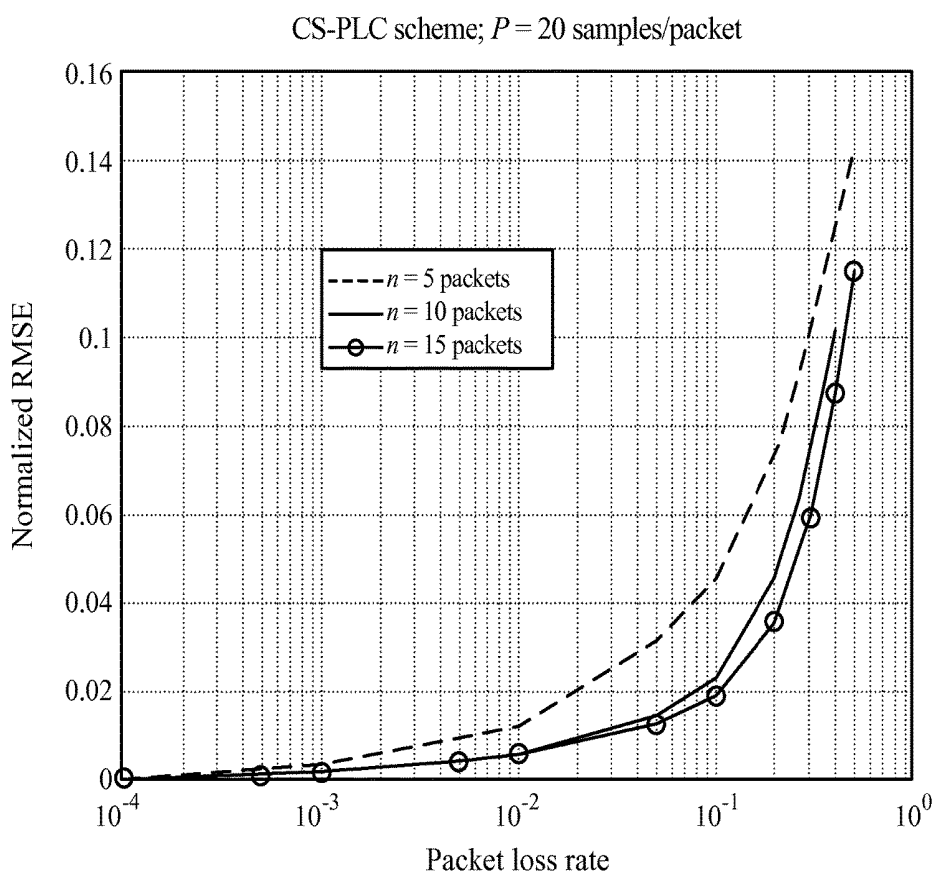

FIG. 19

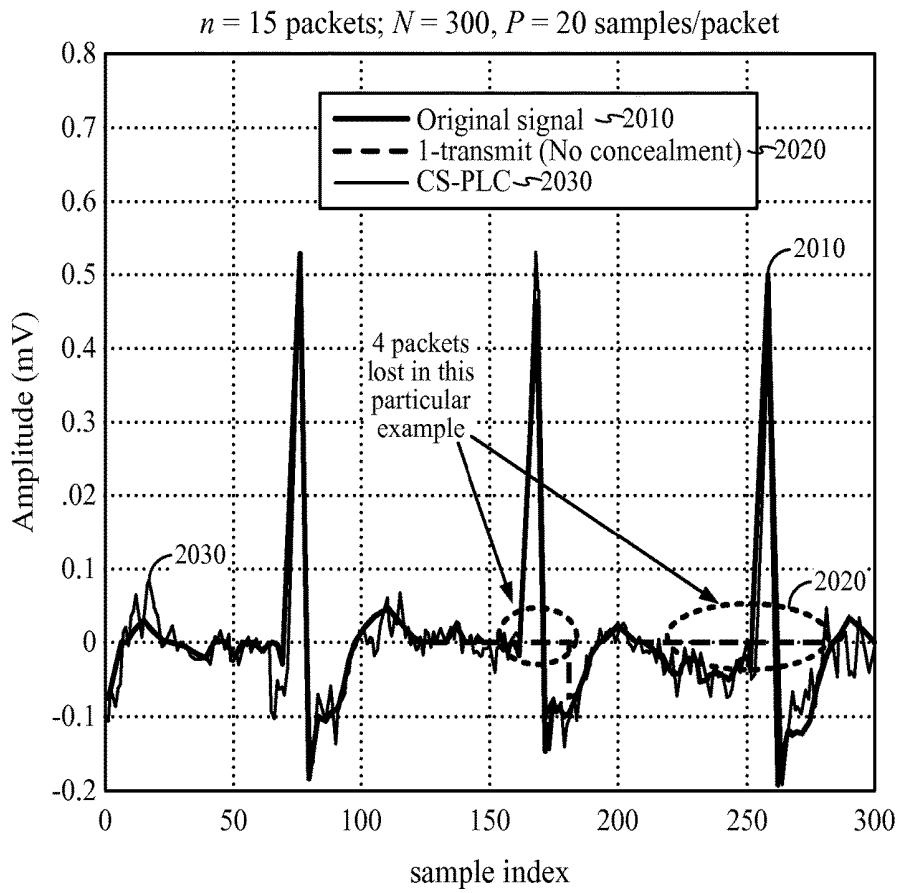

FIG. 20

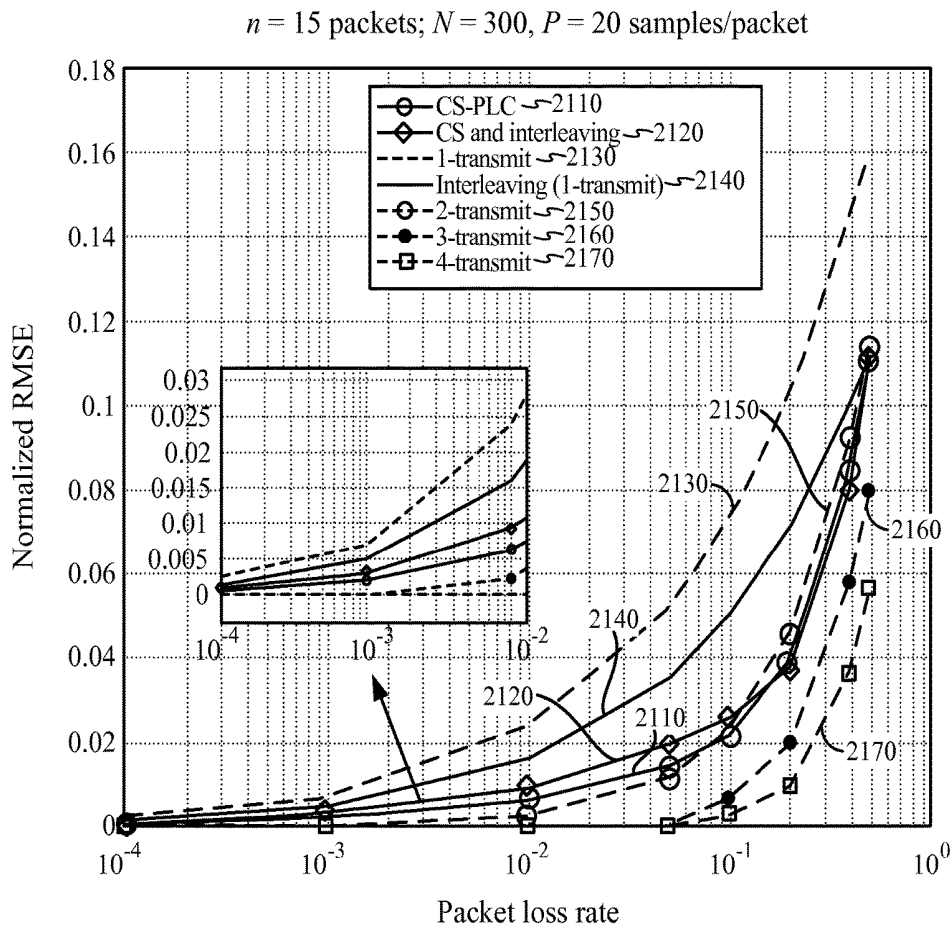

FIG. 21

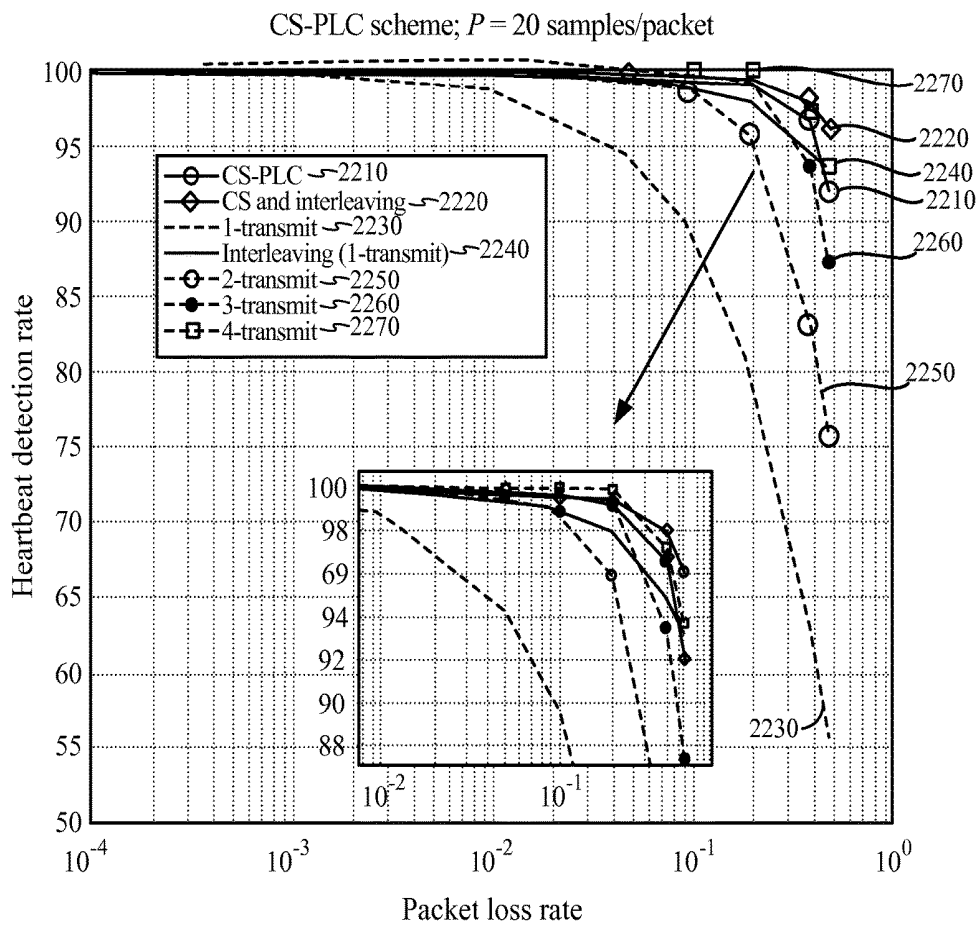

FIG. 22

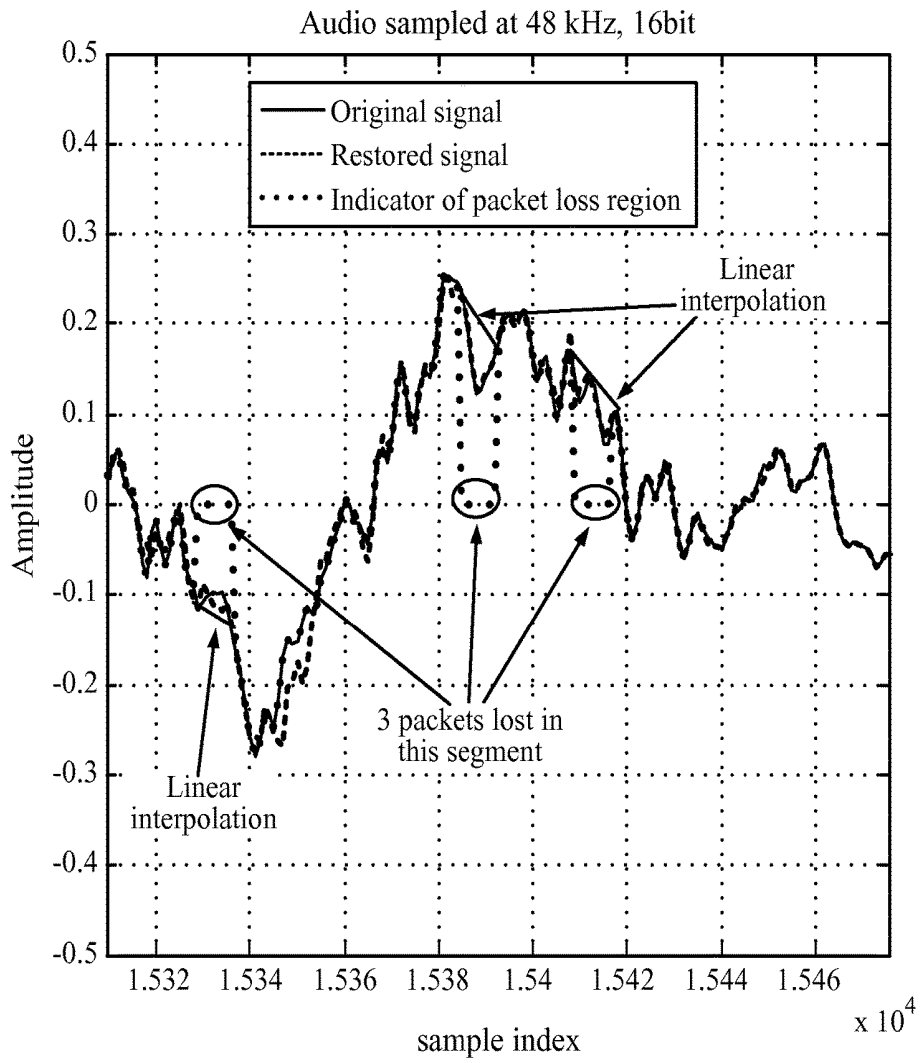

FIG. 23

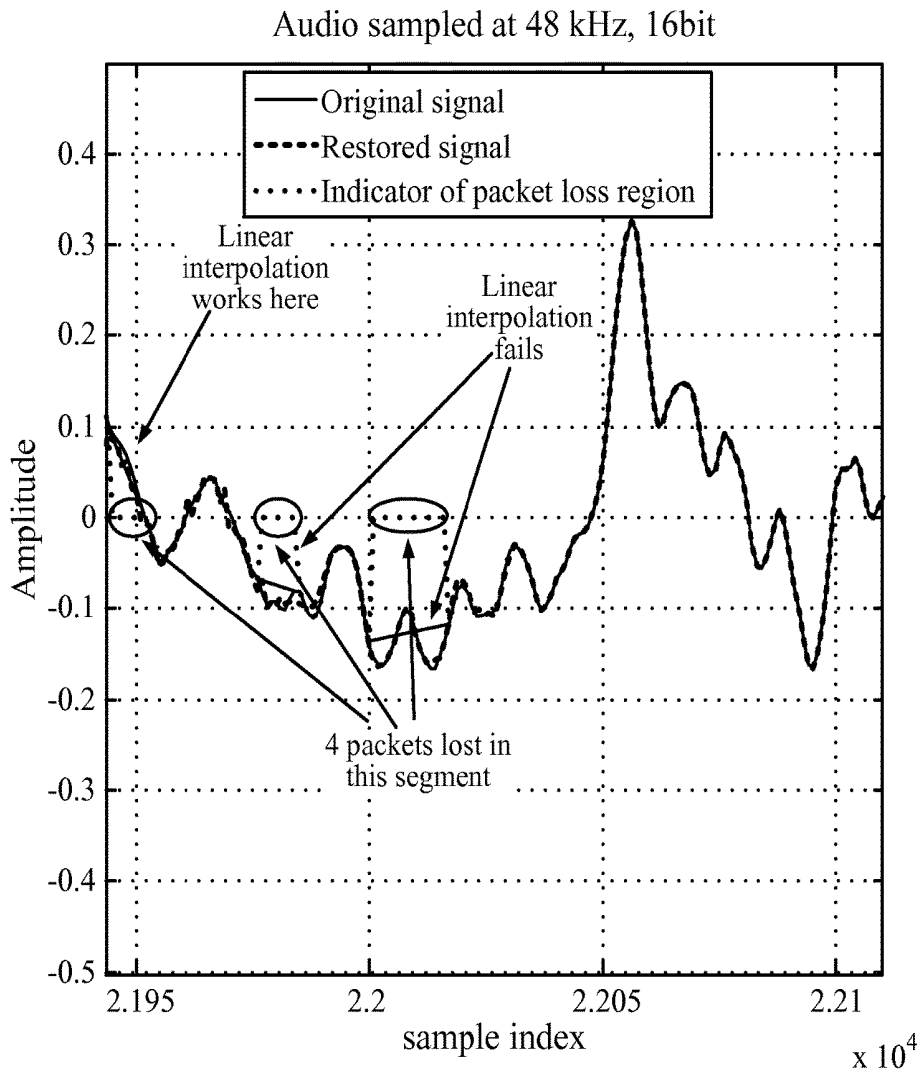

FIG. 24

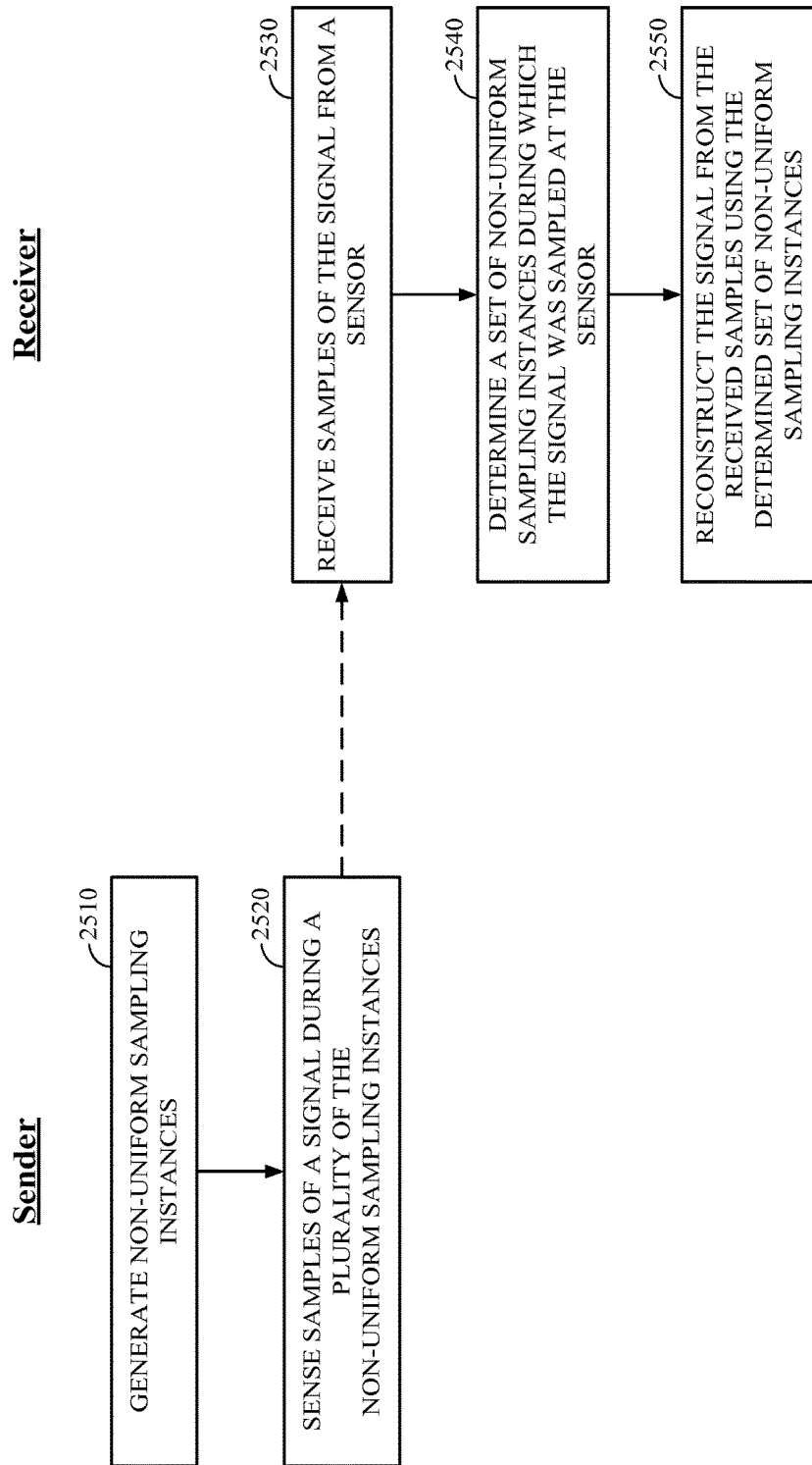

FIG. 25

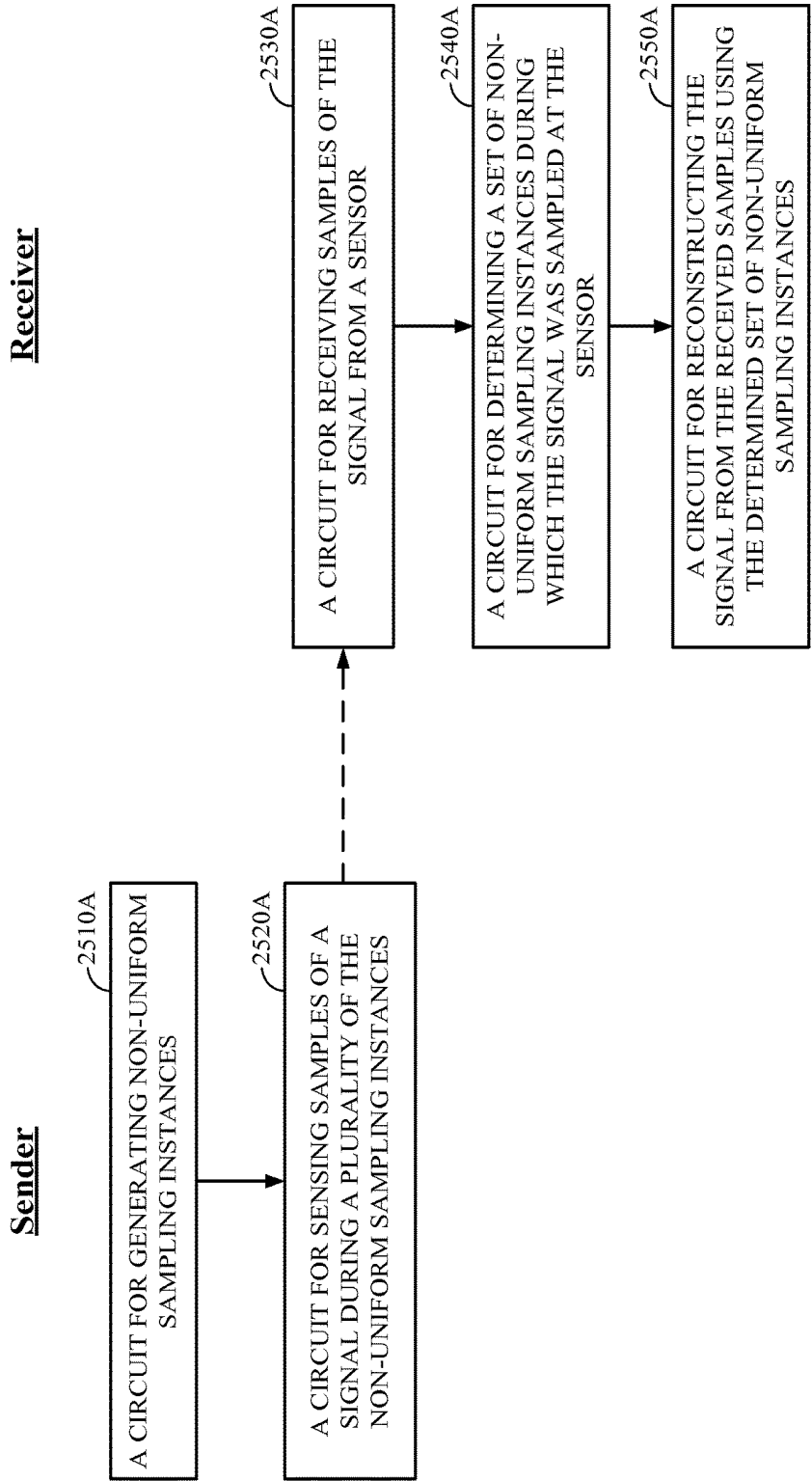

FIG. 25A

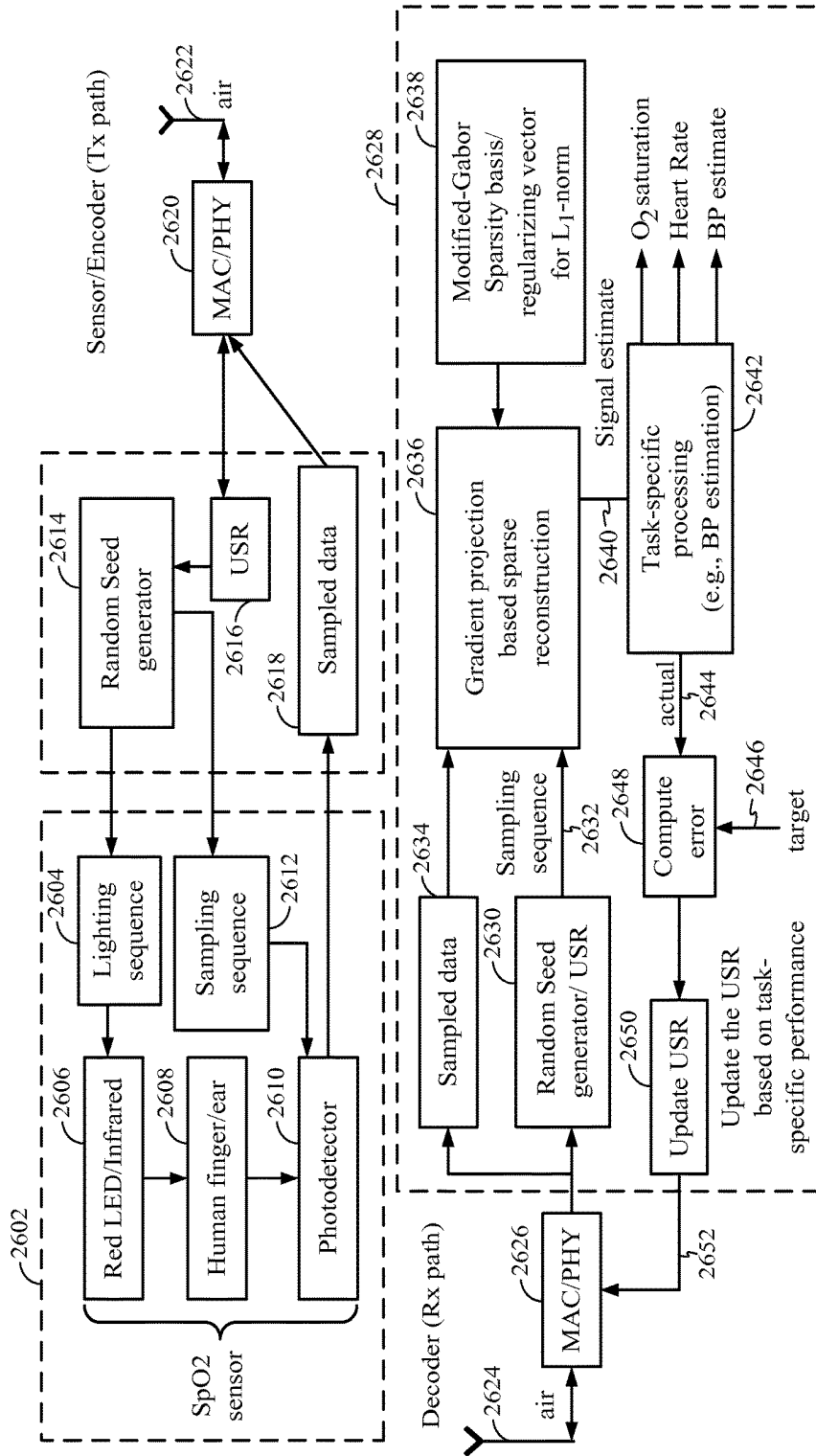

FIG. 26

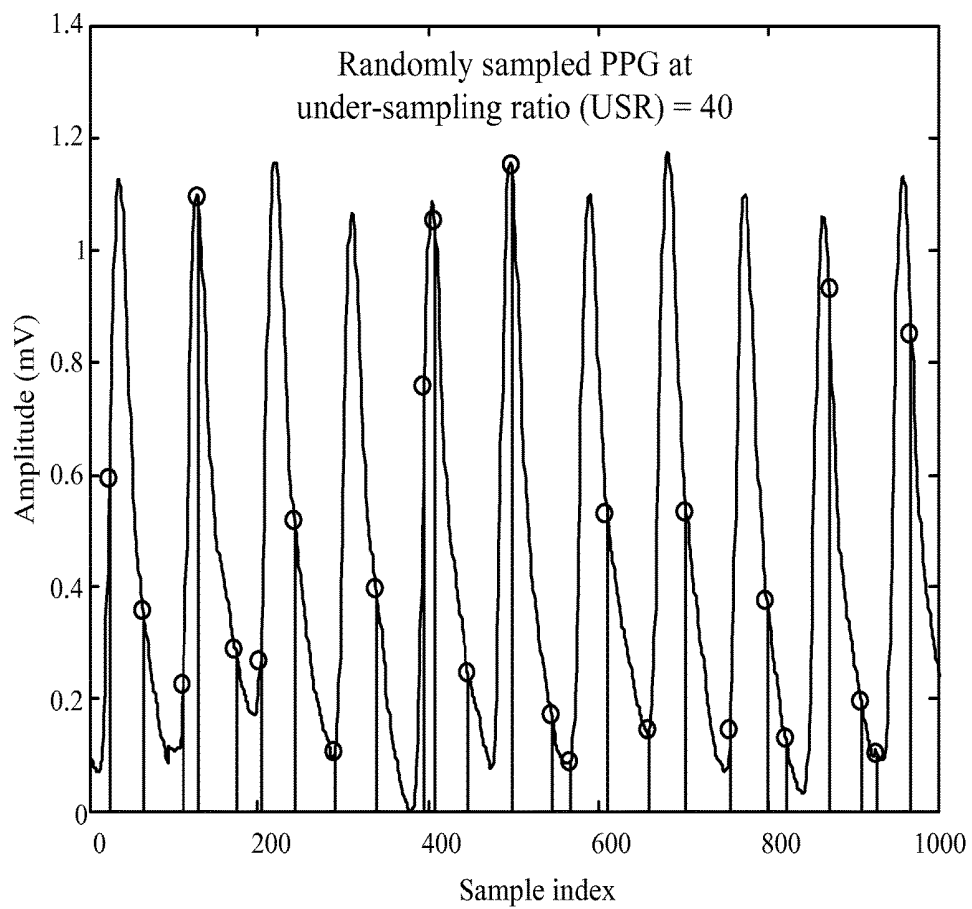

FIG. 27

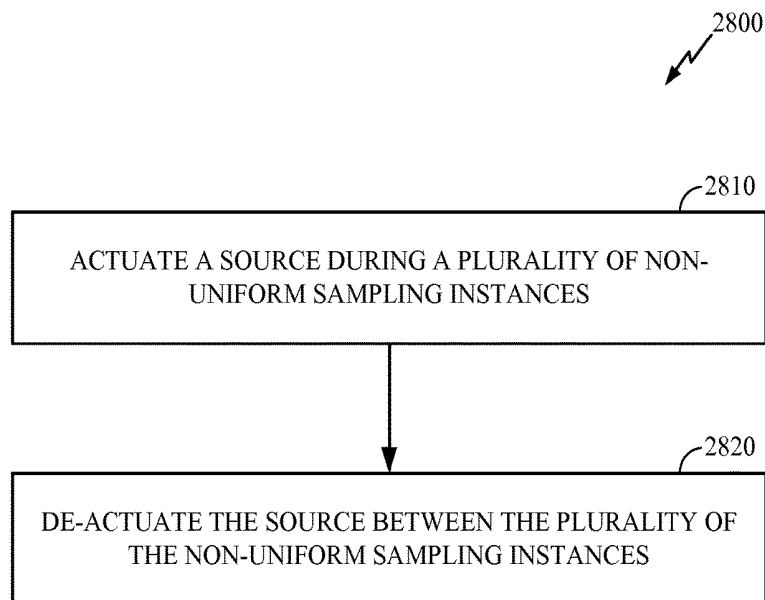

FIG. 28

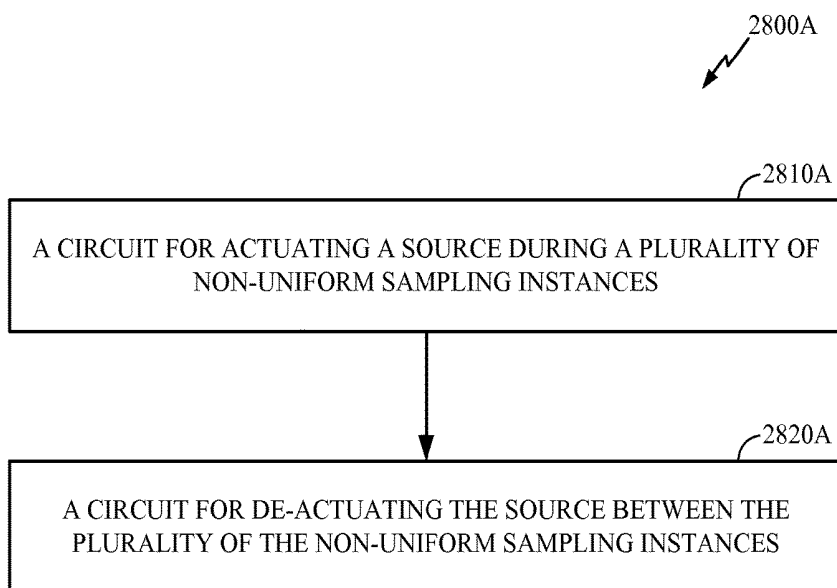

FIG. 28A

**METHOD AND APPARATUS FOR  
UNDER-SAMPLED ACQUISITION AND  
TRANSMISSION OF  
PHOTOPLETHYSMOGRAPH (PPG) DATA  
AND RECONSTRUCTION OF FULL BAND  
PPG DATA AT THE RECEIVER**

CLAIM OF PRIORITY UNDER 35 U.S.C. § 119

The present Application for Patent claims priority to Provisional Application No. 61/100,654 filed Sep. 26, 2008 and Provisional Application No. 61/101,056 filed Sep. 29, 2008, and assigned to the assignee hereof and hereby expressly incorporated by reference herein.

BACKGROUND

Field

Certain aspects of the present disclosure generally relate to signal processing and, more particularly, to a method for under-sampled acquisition, transmission, and reconstruction of a signal.

Background

Compressed sensing (CS) is an emerging signal processing concept, wherein significantly fewer sensor measurements than that suggested by Shannon/Nyquist sampling theorem can be used to recover signals with arbitrarily fine resolution. This is possible when the signals being sensed are inherently compressible or sparse in certain domain. A class of band-limited signals with  $M$  non-zero spectral components is considered, where  $M \ll f_s/2$  and  $f_s$  is a suggested sampling rate, such as the Nyquist sampling rate. Traditionally, such signals can be compressed after acquisition for more efficient transmission and/or storage.

In the CS framework, the acquisition process (i.e., sensing) can be integral to source compression and can be independent of the sparse nature of the signals. However, this sparsity information can be required at a receiver side in order to perform signal reconstruction. Measurements in the CS framework are generally defined as inner products of the signal with random basis functions. These signals can be accurately recovered if at least  $2M$  samples are available at the receiver, albeit with some additional computational complexity at the receiver. This can be useful in the context of a body area network (BAN) as the computational complexity is shifted to nodes with flexible power budget in order to increase working life of sensors employed in the BAN.

The CS paradigm can be used for applications concerning signal detection/classification, imaging, data compression and Magnetic Resonance Imaging (MRI). Benefits of the CS are reported in terms of improved signal fidelity and superior recognition performance. In the present disclosure, the CS-based signal processing is proposed for providing low power sensors within the BAN for healthcare and fitness applications.

Important aspect of the BAN in healthcare applications is to provide a reliable communication link between sensors (i.e., transmitters) and an aggregator (i.e., a receiver), while minimizing sensor power and communication latency. It is previously reported that up to 50% packet loss rates are observed involving a multi-hop wireless network. However, the packet loss performance can be improved by employing Quality of Service (QoS) aware networks. A dual-channel

approach can be applied where one channel may be reserved for emergency alert messages. As the result, lower packet loss rates of 5% to 25% can be observed. However, the packet loss rate can increase with network congestion.

Furthermore, the use of Forward Error Correction (FEC) coding within the BAN scenarios is explored. By using FEC schemes, it can be observed a small residual packet loss rate for communication latency on the order of seconds. Also, transmission of an electrocardiogram (ECG) signal over the General Packet Radio Service (GPRS) link is investigated, and a small loss rate is achieved for communication latency on the order of seconds. The benefits of using FEC come at the cost of increased transmission bandwidth and sensor complexity. On the other hand, a technique based on retransmissions has smaller bandwidth penalty compared to the FEC approach, but sensor complexity is considerable as packets need to be buffered at a transmitter. There is also a latency penalty proportional to a round trip time.

Therefore, there is a need in the art for methods with lower bandwidth overhead and lower computational complexity at the transmitter leading to a longer sensor life, while not compromising application specific objective quality metrics for a given packet loss rate.

SUMMARY

Certain aspects provide a method for signal processing. The method generally includes generating, at an apparatus, non-uniform sampling instances, and sensing samples of a signal during a plurality of the non-uniform sampling instances.

Certain aspects provide an apparatus for signal processing. The apparatus generally includes a generator configured to generate non-uniform sampling instances, and a sensor configured to sense samples of a signal during a plurality of the non-uniform sampling instances.

Certain aspects provide an apparatus for signal processing. The apparatus generally includes means for generating non-uniform sampling instances, and means for sensing samples of a signal during a plurality of the non-uniform sampling instances.

Certain aspects provide a computer-program product for signal processing. The computer-program product includes a computer-readable medium comprising instructions executable to generate non-uniform sampling instances, and sense samples of a signal during a plurality of the non-uniform sampling instances.

Certain aspects provide a sensing device. The sensing device generally includes a generator configured to generate non-uniform sampling instances, a sensor configured to sense samples of a signal at least during a plurality of the non-uniform sampling instances, and a transmitter configured to transmit the sensed samples.

Certain aspects provide a method for signal processing. The method generally includes receiving, at an apparatus, samples of a signal from another apparatus, determining a set of non-uniform sampling instances during which signal was sampled at the other apparatus, and reconstructing the signal from the received samples using the determined set of non-uniform sampling instances.

Certain aspects provide an apparatus for signal processing. The apparatus generally includes a receiver configured to receive samples of a signal transmitted from another apparatus, a circuit configured to determine a set of non-uniform sampling instances during which signal was sampled at the other apparatus, and a re-constructor config-

ured to reconstruct the signal from the received samples using the determined set of non-uniform sampling instances.

Certain aspects provide an apparatus for signal processing. The apparatus generally includes means for receiving samples of a signal transmitted from another apparatus, means for determining a set of non-uniform sampling instances during which signal was sampled at the other apparatus, and means for reconstructing the signal from the received samples using the determined set of non-uniform sampling instances.

Certain aspects provide a computer-program product for signal processing. The computer-program product includes a computer-readable medium comprising instructions executable to receive samples of a signal transmitted from an apparatus, determine a set of non-uniform sampling instances during which signal was sampled at the apparatus, and reconstruct the signal from the received samples using the determined set of non-uniform sampling instances.

Certain aspects provide a headset. The headset generally includes a receiver configured to receive samples of a signal transmitted from an apparatus, a circuit configured to determine a set of non-uniform sampling instances during which signal was sampled at the apparatus, a re-constructor configured to reconstruct the signal from the received samples using the determined set of non-uniform sampling instances; and a transducer configured to provide an audio output based on the reconstructed signal.

Certain aspects provide a watch. The watch generally includes a receiver configured to receive samples of a signal transmitted from an apparatus, a circuit configured to determine a set of non-uniform sampling instances during which signal was sampled at the apparatus, a re-constructor configured to reconstruct the signal from the received samples using the determined set of non-uniform sampling instances; and a user interface configured to provide an indication based on the reconstructed signal.

Certain aspects provide a monitoring device. The monitoring device generally includes a connector, a receiver configured to receive via the connector samples of a signal transmitted from an apparatus, a circuit configured to determine a set of non-uniform sampling instances during which signal was sampled at the apparatus, a re-constructor configured to reconstruct the signal from the received samples using the determined set of non-uniform sampling instances, and a user interface configured to provide an indication based on the reconstructed signal.

Certain aspects provide a method for signal processing. The method generally includes actuating a source during a plurality of non-uniform sampling instances, and de-actuating the source between the plurality of the non-uniform sampling instances.

Certain aspects provide an apparatus for signal processing. The apparatus generally includes an actuating circuit configured to actuate a source during a plurality of non-uniform sampling instances, and a de-actuating circuit configured to de-actuate the source between the plurality of the non-uniform sampling instances.

Certain aspects provide an apparatus for signal processing. The apparatus generally includes means for actuating a source during a plurality of non-uniform sampling instances, and means for de-actuating the source between the plurality of the non-uniform sampling instances.

Certain aspects provide a computer-program product for signal processing. The computer-program product includes a computer-readable medium comprising instructions executable to actuate a source during a plurality of non-uniform

sampling instances, and de-actuate the source between the plurality of the non-uniform sampling instances.

Certain aspects provide a sensing device. The sensing device generally includes an actuating circuit configured to actuate a source during a plurality of non-uniform sampling instances, a sensor configured to sense samples of a signal during the plurality of the non-uniform sampling instances, and a de-actuating circuit configured to de-actuate the source between the plurality of the non-uniform sampling instances.

#### BRIEF DESCRIPTION OF THE DRAWINGS

So that the manner in which the above-recited features of the present disclosure can be understood in detail, a more particular description, briefly summarized above, may be had by reference to aspects, some of which are illustrated in the appended drawings. It is to be noted, however, that the appended drawings illustrate only certain typical aspects of this disclosure and are therefore not to be considered limiting of its scope, for the description may admit to other equally effective aspects.

FIG. 1 illustrates an example wireless communication system, in accordance with certain aspects of the present disclosure.

FIG. 2 illustrates various components that may be utilized in a wireless device in accordance with certain aspects of the present disclosure.

FIG. 3 illustrates an example transmitter and an example receiver that may be used within a wireless communication system in accordance with certain aspects of the present disclosure.

FIG. 4 illustrates an example of a body area network (BAN) in accordance with certain aspects of the present disclosure.

FIG. 5 illustrates an example block diagram of array of sensors used within the BAN in accordance with certain aspects of the present disclosure.

FIG. 6 illustrates an example block diagram of an aggregator used within the BAN in accordance with certain aspects of the present disclosure.

FIG. 7 illustrates an example of a time-domain photoplethysmograph (PPG) signal and its frequency spectrum in accordance with certain aspects of the present disclosure.

FIG. 8 illustrates an example of a time-domain electrocardiogram (ECG) signal and its frequency spectrum in accordance with certain aspects of the present disclosure.

FIG. 9 illustrates another example of a frequency spectrum of a PPG signal in accordance with certain aspects of the present disclosure.

FIG. 10 illustrates an example of a PPG signal and its transform in the Gabor space in accordance with certain aspects of the present disclosure.

FIG. 11 illustrates a comparison of reconstructed signals obtained using different under-sampling ratios (USRs) in accordance with certain aspects of the present disclosure.

FIG. 12 illustrates a comparison of a heart rate (HR) estimation based on a compressed sensing (CS) framework for different USRs in accordance with certain aspects of the present disclosure.

FIG. 13 illustrates a comparison of PPG signal reconstruction based on the CS framework for different USRs in accordance with certain aspects of the present disclosure.

FIG. 14 illustrates an example measurement of a pulse arrival time (PAT) and the HR based on ECG and PPG signal peaks in accordance with certain aspects of the present disclosure.

FIG. 15 illustrates standard deviations for a systolic blood pressure (SBP) estimation error and a diastolic blood pressure (DBP) estimation error in accordance with certain aspects of the present disclosure.

FIG. 16 illustrates example operations for CS-based packet loss concealment (PLC) method in accordance with certain aspects of the present disclosure.

FIG. 16A illustrates example components capable of performing the operations illustrated in FIG. 16.

FIG. 17 illustrates an example ECG signal, its transform in the Gabor space and a precoded version of the ECG signal in accordance with certain aspects of the present disclosure.

FIG. 18 illustrates example operations for interleaving-based CS-PLC method in accordance with certain aspects of the present disclosure.

FIG. 18A illustrates example components capable of performing the operations illustrated in FIG. 18.

FIG. 19 illustrates a graph of example root-mean-square-error (RMSE) performance of the CS-PLC for different number of transmitted packets in accordance with certain aspects of the present disclosure.

FIG. 20 illustrates an example of signal reconstruction using the CS-PLC approach and a scheme without PLC in accordance with certain aspects of the present disclosure.

FIG. 21 illustrates a graph of example normalized RMSE performance for various PLC schemes in accordance with certain aspects of the present disclosure.

FIG. 22 illustrates heart beat detection performance comparisons for various PLC schemes in accordance with certain aspects of the present disclosure.

FIG. 23 illustrates an example of a restored audio signal using the CS-PLC scheme in accordance with certain aspects of the present disclosure.

FIG. 24 illustrates another example of a restored audio signal using the CS-PLC scheme in accordance with certain aspects of the present disclosure.

FIG. 25 illustrates example operations for under-sampled acquisition and reconstruction in accordance with certain aspects of the present disclosure.

FIG. 25A illustrates example components capable of performing the operations illustrated in FIG. 25.

FIG. 26 illustrates an example block diagram of a sensor and a re-constructor in accordance with certain aspects of the present disclosure.

FIG. 27 illustrates an example of a signal sensed at non-uniform sampling instances in accordance with certain aspects of the present disclosure.

FIG. 28 illustrates example operations for actuating and de-actuating a source at the sensor in accordance with certain aspects of the present disclosure.

FIG. 28A illustrates example components capable of performing the operations illustrated in FIG. 28.

#### DETAILED DESCRIPTION

Various aspects of the disclosure are described more fully hereinafter with reference to the accompanying drawings. This disclosure may, however, be embodied in many different forms and should not be construed as limited to any specific structure or function presented throughout this disclosure. Rather, these aspects are provided so that this disclosure will be thorough and complete, and will fully convey the scope of the disclosure to those skilled in the art. Based on the teachings herein one skilled in the art should appreciate that the scope of the disclosure is intended to cover any aspect of the disclosure disclosed herein, whether implemented independently of or combined with any other

aspect of the disclosure. For example, an apparatus may be implemented or a method may be practiced using any number of the aspects set forth herein. In addition, the scope of the disclosure is intended to cover such an apparatus or method which is practiced using other structure, functionality, or structure and functionality in addition to or other than the various aspects of the disclosure set forth herein. It should be understood that any aspect of the disclosure disclosed herein may be embodied by one or more elements of a claim.

The word “exemplary” is used herein to mean “serving as an example, instance, or illustration.” Any aspect described herein as “exemplary” is not necessarily to be construed as preferred or advantageous over other aspects.

Although particular aspects are described herein, many variations and permutations of these aspects fall within the scope of the disclosure. Although some benefits and advantages of the preferred aspects are mentioned, the scope of the disclosure is not intended to be limited to particular benefits, uses, or objectives. Rather, aspects of the disclosure are intended to be broadly applicable to different wireless technologies, system configurations, networks, and transmission protocols, some of which are illustrated by way of example in the figures and in the following description of the preferred aspects. The detailed description and drawings are merely illustrative of the disclosure rather than limiting, the scope of the disclosure being defined by the appended claims and equivalents thereof.

#### An Example Wireless Communication System

The techniques described herein may be used for various broadband wireless communication systems, including communication systems that are based on an orthogonal multiplexing scheme and a single carrier transmission. Examples of such communication systems include Orthogonal Frequency Division Multiple Access (OFDMA) systems, Single-Carrier Frequency Division Multiple Access (SC-FDMA) systems, Code Division Multiple Access (CDMA), and so forth. An OFDMA system utilizes orthogonal frequency division multiplexing (OFDM), which is a modulation technique that partitions the overall system bandwidth into multiple orthogonal sub-carriers. These sub-carriers may also be called tones, bins, etc. With OFDM, each sub-carrier may be independently modulated with data. An SC-FDMA system may utilize interleaved FDMA (IFDMA) to transmit on sub-carriers that are distributed across the system bandwidth, localized FDMA (LFDMA) to transmit on a block of adjacent sub-carriers, or enhanced FDMA (EFDMA) to transmit on multiple blocks of adjacent sub-carriers. In general, modulation symbols are sent in the frequency domain with OFDM and in the time domain with SC-FDMA. A CDMA system may utilize spread-spectrum technology and a coding scheme where each transmitter (i.e., user) is assigned a code in order to allow multiple users to be multiplexed over the same physical channel.

One specific example of a communication system based on an orthogonal multiplexing scheme is a WiMAX system. WiMAX, which stands for the Worldwide Interoperability for Microwave Access, is a standards-based broadband wireless technology that provides high-throughput broadband connections over long distances. There are two main applications of WiMAX today: fixed WiMAX and mobile WiMAX. Fixed WiMAX applications are point-to-multipoint, enabling broadband access to homes and businesses, for example. Mobile WiMAX offers the full mobility of cellular networks at broadband speeds.

IEEE 802.16x is an emerging standard organization to define an air interface for fixed and mobile broadband wireless access (BWA) systems. IEEE 802.16x approved “IEEE P802.16d/D5-2004” in May 2004 for fixed BWA systems and published “IEEE P802.16e/D12 Oct. 2005” in October 2005 for mobile BWA systems. The latest revision of the IEEE 802.16, “IEEE P802.16Rev2/D8 December 2008”, a draft standard, now consolidates materials from IEEE 802.16e and corrigendum. The standards define four different physical layers (PHYs) and one medium access control (MAC) layer. The OFDM and OFDMA physical layer of the four physical layers are the most popular in the fixed and mobile BWA areas respectively.

The teachings herein may be incorporated into (e.g., implemented within or performed by) a variety of wired or wireless apparatuses (e.g., nodes). In some aspects, a node implemented in accordance with the teachings herein may comprise an access point or an access terminal.

An access point (“AP”) may comprise, be implemented as, or known as NodeB, Radio Network Controller (“RNC”), eNodeB, Base Station Controller (“BSC”), Base Transceiver Station (“BTS”), Base Station (“BS”), Transceiver Function (“TF”), Radio Router, Radio Transceiver, Basic Service Set (“BSS”), Extended Service Set (“ESS”), Radio Base Station (“RBS”), or some other terminology.

An access terminal (“AT”) may comprise, be implemented as, or known as an access terminal, a subscriber station, a subscriber unit, a mobile station, a remote station, a remote terminal, a user terminal, a user agent, a user device, user equipment, or some other terminology. In some implementations an access terminal may comprise a cellular telephone, a cordless telephone, a Session Initiation Protocol (“SIP”) phone, a wireless local loop (“WLL”) station, a personal digital assistant (“PDA”), a handheld device having wireless connection capability, or some other suitable processing device connected to a wireless modem. Accordingly, one or more aspects taught herein may be incorporated into a phone (e.g., a cellular phone or smart phone), a computer (e.g., a laptop), a portable communication device, a portable computing device (e.g., a personal data assistant), an entertainment device (e.g., a music or video device, or a satellite radio), a global positioning system device, or any other suitable device that is configured to communicate via a wireless or wired medium. In some aspects the node is a wireless node. Such wireless node may provide, for example, connectivity for or to a network (e.g., a wide area network such as the Internet or a cellular network) via a wired or wireless communication link.

FIG. 1 illustrates an example of a wireless communication system **100** in which aspects of the present disclosure may be employed. The wireless communication system **100** may be a broadband wireless communication system. The wireless communication system **100** may provide communication for a number of cells **102**, each of which is serviced by a base station **104**. A base station **104** may be a fixed station that communicates with user terminals **106**. The base station **104** may alternatively be referred to as an access point, a Node B or some other terminology.

FIG. 1 depicts various user terminals **106** dispersed throughout the system **100**. The user terminals **106** may be fixed (i.e., stationary) or mobile. The user terminals **106** may alternatively be referred to as remote stations, access terminals, terminals, subscriber units, mobile stations, stations, user equipment, etc. The user terminals **106** may be wireless devices, such as cellular phones, personal digital assistants (PDAs), handheld devices, wireless modems, laptop computers, personal computers, etc.

A variety of algorithms and methods may be used for transmissions in the wireless communication system **100** between the base stations **104** and the user terminals **106**. For example, signals may be sent and received between the base stations **104** and the user terminals **106** in accordance with OFDM/OFDMA techniques. If this is the case, the wireless communication system **100** may be referred to as an OFDM/OFDMA system. Alternatively, signals may be sent and received between the base stations **104** and the user terminals **106** in accordance with CDMA technique. If this is the case, the wireless communication system **100** may be referred to as a CDMA system.

A communication link that facilitates transmission from a base station **104** to a user terminal **106** may be referred to as a downlink (DL) **108**, and a communication link that facilitates transmission from a user terminal **106** to a base station **104** may be referred to as an uplink (UL) **110**. Alternatively, a downlink **108** may be referred to as a forward link or a forward channel, and an uplink **110** may be referred to as a reverse link or a reverse channel.

A cell **102** may be divided into multiple sectors **112**. A sector **112** is a physical coverage area within a cell **102**. Base stations **104** within a wireless communication system **100** may utilize antennas that concentrate the flow of power within a particular sector **112** of the cell **102**. Such antennas may be referred to as directional antennas.

FIG. 2 illustrates various components that may be utilized in a wireless device **202** that may be employed within the wireless communication system **100**. The wireless device **202** is an example of a device that may be configured to implement the various methods described herein. The wireless device **202** may be a base station **104** or a user terminal **106**.

The wireless device **202** may include a processor **204** which controls operation of the wireless device **202**. The processor **204** may also be referred to as a central processing unit (CPU). Memory **206**, which may include both read-only memory (ROM) and random access memory (RAM), provides instructions and data to the processor **204**. A portion of the memory **206** may also include non-volatile random access memory (NVRAM). The processor **204** typically performs logical and arithmetic operations based on program instructions stored within the memory **206**. The instructions in the memory **206** may be executable to implement the methods described herein.

The wireless device **202** may also include a housing **208** that may include a transmitter **210** and a receiver **212** to allow transmission and reception of data between the wireless device **202** and a remote location. The transmitter **210** and receiver **212** may be combined into a transceiver **214**. An antenna **216** may be attached to the housing **208** and electrically coupled to the transceiver **214**. The wireless device **202** may also include (not shown) multiple transmitters, multiple receivers, multiple transceivers, and/or multiple antennas.

The wireless device **202** may also include a signal detector **218** that may be used in an effort to detect and quantify the level of signals received by the transceiver **214**. The signal detector **218** may detect such signals as total energy, energy per subcarrier per symbol, power spectral density and other signals. The wireless device **202** may also include a digital signal processor (DSP) **220** for use in processing signals.

The various components of the wireless device **202** may be coupled together by a bus system **222**, which may include a power bus, a control signal bus, and a status signal bus in addition to a data bus.

FIG. 3 illustrates an example of a transmitter 302 that may be used within a wireless communication system 100 that utilizes OFDM/OFDMA. Portions of the transmitter 302 may be implemented in the transmitter 210 of a wireless device 202. The transmitter 302 may be implemented in a base station 104 for transmitting data 306 to a user terminal 106 on a downlink 108. The transmitter 302 may also be implemented in a user terminal 106 for transmitting data 306 to a base station 104 on an uplink 110.

Data 306 to be transmitted is shown being provided as input to a serial-to-parallel (S/P) converter 308. The S/P converter 308 may split the transmission data into M parallel data streams 310.

The N parallel data streams 310 may then be provided as input to a mapper 312. The mapper 312 may map the N parallel data streams 310 onto N constellation points. The mapping may be done using some modulation constellation, such as binary phase-shift keying (BPSK), quadrature phase-shift keying (QPSK), 8 phase-shift keying (8PSK), quadrature amplitude modulation (QAM), etc. Thus, the mapper 312 may output N parallel symbol streams 316, each symbol stream 316 corresponding to one of the N orthogonal subcarriers of the inverse fast Fourier transform (IFFT) 320. These N parallel symbol streams 316 are represented in the frequency domain and may be converted into N parallel time domain sample streams 318 by an IFFT component 320.

A brief note about terminology will now be provided. N parallel modulations in the frequency domain are equal to N modulation symbols in the frequency domain, which are equal to N mapping and N-point IFFT in the frequency domain, which is equal to one (useful) OFDM symbol in the time domain, which is equal to N samples in the time domain. One OFDM symbol in the time domain,  $N_s$ , is equal to  $N_{CP}$  (the number of cyclic prefix (CP) samples per OFDM symbol)+N (the number of useful samples per OFDM symbol).

The N parallel time domain sample streams 318 may be converted into an OFDM/OFDMA symbol stream 322 by a parallel-to-serial (P/S) converter 324. A cyclic prefix insertion component 326 may insert a CP between successive OFDM/OFDMA symbols in the OFDM/OFDMA symbol stream 322. The output of the CP insertion component 326 may then be upconverted to a desired transmit frequency band by a radio frequency (RF) front end 328. An antenna 330 may then transmit the resulting signal 332.

FIG. 3 also illustrates an example of a receiver 304 that may be used within a wireless device 202 that utilizes OFDM/OFDMA. Portions of the receiver 304 may be implemented in the receiver 212 of a wireless device 202. The receiver 304 may be implemented in a user terminal 106 for receiving data 306 from a base station 104 on a downlink 108. The receiver 304 may also be implemented in a base station 104 for receiving data 306 from a user terminal 106 on an uplink 110.

The transmitted signal 332 is shown traveling over a wireless channel 334. When a signal 332' is received by an antenna 330', the received signal 332' may be downconverted to a baseband signal by an RF front end 328'. A CP removal component 326' may then remove the CP that was inserted between OFDM/OFDMA symbols by the CP insertion component 326.

The output of the CP removal component 326' may be provided to an S/P converter 324'. The S/P converter 324' may divide the OFDM/OFDMA symbol stream 322' into the N parallel time-domain symbol streams 318', each of which corresponds to one of the N orthogonal subcarriers. A fast Fourier transform (FFT) component 320' may convert the N

parallel time-domain symbol streams 318' into the frequency domain and output N parallel frequency-domain symbol streams 316'.

A demapper 312' may perform the inverse of the symbol mapping operation that was performed by the mapper 312 thereby outputting N parallel data streams 310'. A P/S converter 308' may combine the N parallel data streams 310' into a single data stream 306'. Ideally, this data stream 306' corresponds to the data 306 that was provided as input to the transmitter 302. Note that elements 308', 310', 312', 316', 320', 318' and 324' may all be found in a baseband processor 340'.

#### Body Area Network Concept

FIG. 4 illustrates an example of a body area network (BAN) 400 that may correspond to the wireless system 100 illustrated in FIG. 1. Body area networks represent a promising concept for healthcare applications such as continuous monitoring for diagnostic purposes, effects of medicines on chronic ailments, etc.

The BAN may consist of several acquisition circuits. Each acquisition circuit may comprise wireless sensor that senses one or more vital signs and communicates them to an aggregator (i.e., an access terminal) such as a mobile handset, a wireless watch, or a Personal Data Assistant (PDA). Sensors 402, 404, 406, and 408 that acquire various biomedical signals and transmit them over a wireless channel to an aggregator 410 may have the same functionality as access points 104. FIG. 5 illustrates detailed block diagram of an array of biomedical sensors 510a-510k that may correspond to sensors 402-408 within the BAN 400. Each sensor 510a-510k may be an example of the transmitter 210 from FIG. 2 and the transmitter 302 from FIG. 3.

The aggregator 410 illustrated in FIG. 4 may receive and process various biomedical signals transmitted over a wireless channel from sensors 402-408. The aggregator 410 may be a mobile handset or a PDA, and may have the same functionality as a mobile device 106 from FIG. 1. FIG. 6 illustrates a detailed block diagram of an aggregator 610 that may correspond to the aggregator 410 within the BAN 400. The aggregator 610 may be an example of the receiver 212 from FIG. 2 and the receiver 304 from FIG. 3.

It is desirable for sensors used in the BAN to be non-intrusive and long lasting. Photoplethysmograph (PPG) and Electro Cardiogram (ECG) signals may be considered in this disclosure to demonstrate benefits of compressed sensing (CS) techniques for sensor signal processing. The PPG, the ECG and the activity sensing cover a large percentage of chronic ailments in a large segment of human population, and thus provide significant opportunities for wireless technologies in the BAN and mobile devices with wireless area network (WAN) connectivity.

Pulse oximeter sensors can generate the PPG waveform which may enable continuous monitoring of blood oxygenation (also called  $S_pO_2$ ), a crucial indicator of pulmonary system including lungs and respiration. A blood carries oxygen, nutrients and chemicals to the body cells in order to ensure their survival, proper functioning and to remove the cellular wastes.  $S_pO_2$  is extensively used in clinical settings for diagnosis, surgery, long term monitoring, etc. FIG. 7 illustrates an example of a time-domain PPG signal and its frequency spectrum.

The ECG is another important vital sign for assessing the cardiovascular system. Heart is one of the most hard working body parts, pumping about six liters of blood per minute through the body in humans. Electrical signals generated

during each cardiac cycle form the ECG and can be easily captured by Ag/AgCl electrode sensors. The ECG may be routinely used in clinical settings for diagnosing heart related problems and continuous monitoring of the ECG may enable early diagnosis of many chronic conditions. FIG. 8 illustrates an example of a time-domain ECG signal and its frequency spectrum.

A blood pressure (BP) is another vital sign with enormous clinical value. A systolic blood pressure (SBP) and a diastolic blood pressure (DBP) may be estimated using the ECG and the PPG signals.

#### Overview of Proposed Methods

Certain aspects of the present disclosure relates to methods for reducing power consumption of a pulse oximeter sensor. Commercial pulse oximeters may typically consume power in the order of 20-60 mW. The red and infrared light-emitting diodes (LEDs) account for most of this power. A power-efficient design for a PPG sensor may bring the power consumption down to 1.5 mW. The duty cycle associated with LED lighting may be reduced for a given uniform sampling rate. Fast detectors and higher clock frequencies may be used among other optimizations. Thus, the LED may be switched on for  $T \cdot f_s$  duration, where  $f_s$  and  $T$  represent the sampling rate and duration of lighting required to acquire each sample, respectively.

The PPG signals may be sparse in a spectral domain, and hence compressible. This may enable the usage of a compressed sensing (CS) framework in order to acquire the PPG signals. The PPG signals may be sampled at non-uniform (i.e., random) time intervals, but with an average sampling rate of  $F_s$ . In the CS approach, the sampling rate  $F_s$  may be much smaller than the uniform sampling rate  $f_s$ . A factory  $f_s/F_s$  may be referred as an under-sampling ratio (USR). It can be noted that this sampling approach may result in a reduced power consumption (i.e., approximately by a factor of USR) of pulse oximeter sensors used for PPG acquisition, as the LED may be lit up for only  $T \cdot f_s / \text{USR}$  duration instead of  $T \cdot f_s$ .

A benefit of the CS-based approach compared to low pass filtering and sampling at  $f_s / \text{USR}$  is that the signal content above  $f_s / \text{USR}$  may not be lost. Similarly, narrow-band signals at higher frequencies may also be acquired with a high USR. FIG. 9 illustrates an example spectrum of the PPG signal sampled at  $f_s = 125$  Hz. It can be observed that significant spectral content may be lost if only a low-pass filter is applied to the PPG signal and sampled at  $f_s / 40 = 3.125$  Hz for an USR of 40.

Another benefit of utilizing the CS framework is that the measurements may be independent of the transform space used at reconstruction, including the Fourier space as in traditional Nyquist rate sampling. The CS measurement framework may translate into significant power-savings on the sensor side at the cost of increased computational overhead at the receiver to reconstruct an approximation of the PPG signal.

It is also interesting to evaluate the receiver complexity for a given task, as required computations may be hosted on a mobile handset or a PDA. For example, heart rate (HR) estimation task may not require an intermediate representation of the PPG signal from the CS samples, and thus the post-processing complexity can be different for tasks such as PPG signal reconstruction and HR estimation.

A multi-parameter intelligent monitoring for intensive care (MIMIC) database can be used to demonstrate that the HR and BP estimation accuracy may not be compromised in

the CS framework with different values of USR. The MIMIC database consists of simultaneous recordings of ECG, PPG and BP from several hemodynamically unstable subjects (i.e., subjects whose ECG, PPG and BP patterns may vary during a given period of observation) spanning over more than 24 hours.

Certain aspects of the present disclosure support utilizing the CS framework for packet loss mitigation during transmission of signals. This can be possible because the receiver may be equipped to reconstruct signals from a sparse representation. Wireless transport of biomedical signals from the sensing module to the aggregator is considered. For example, raw ECG data may be encoded using random projections (e.g., Rademacher patterns), and resulting random coefficients may be packetized for transmission over the air.

The sparse nature of the encoded ECG signal may allow performing a reconstruction using a subset of these random coefficients, where the subset cardinality may depend upon sparsity information. This suggests that the ECG signal may be still reconstructed and the HR estimation may be performed at the receiver despite losing some packets due to channel errors. A benefit of this approach is that retransmissions may not be required, resulting in a lower latency and a simpler protocol stack at the sensor. Another salient aspect may be that the number of random projections (i.e., a compressed sensing bandwidth) may be adapted according to channel conditions.

#### Compressed Sensing Based Acquisition and Reconstruction

FIG. 26 illustrates an example block diagram for sensing and reconstruction of biomedical signals. A sensor 2602 for acquiring biomedical signals, such as a PPG signal, may comprise three main components: LEDs 2606, a photo-detector 2610, and lighting and sampling sequence for LEDs and photo-detector 2604 and 2612, respectively. The LEDs 2606 may emit light with wavelengths between 600 nm and 1000 nm, which also comprises red and infrared parts of the spectrum. The light from the LEDs 2606 may be transmitted/reflected from a tissue 2608 (e.g., a human finger or ear, as illustrated in FIG. 26) and may be collected on the photo-detector 2610. The ratio of the average intensities corresponding to the LEDs measured at the photo-detector may be useful in determining the oxygen content ( $S_p O_2$ ) in blood. Thus,  $S_p O_2$  may be a function of the mean (DC content) of the PPG signal.

The lighting sequence 2604 and the sampling sequence 2612 may be obtained using a random seed generated by a seed generator 2614 according to a defined under-sampling ratio (USR) 2616. The sampled data 2618 from the photo-detector 2610 may be sent for Media Access Control/Physical Layer (MAC/PHY) processing 2620 before transmission. The processed samples may be then packetized and transmitted by one or more antennas 2622.

At a receiver side, as illustrated in FIG. 26, the transmitted samples may be received at one or more antennas 2624 and processed by MAC/PHY block 2626. The data may be then passed to a re-constructor 2628 for obtaining the originally sensed biomedical signal. For the accurate reconstruction, a random seed generator 2630 that generates a sampling sequence 2632 may need to be synchronized with the random seed generator 2614 of the sensor.

In one aspect of the present disclosure, a gradient based sparse reconstruction 2636 may be applied on sampled data 2634 by using, for example, a modified-Gabor sparsity basis

regularizing vector for  $l_1$ -norm **2638**. An estimated signal **2640** may be then utilized by unit **2642** for task-specific processing in order to obtain, for example, a blood pressure estimate, a level of the oxygen in blood, and a heart rate. An actual signal **2644** may be compared with a target signal **2646** by unit **2648** in order to update USR utilized for generating sampling instances. An updated USR value **2652** at the output of unit **2650** may be used by the random seed generator **2630**, and may be also fed back to the sensor for adapting the USR **2616** of the sensor. Beside the USR, additional feedback information may be also transmitted to the sensor for adapting some other parameters, such as: a number of measurements at the sensor, coefficients of a measurement matrix, a number of transmitted samples of the signal, and a number of samples in each transmitted packet.

Modulations in the PPG waveform (associated with either red or infrared LEDs) may be related to the instantaneous blood flow. Instantaneous heart rate (HR) may be estimated as the inverse of the distance between waveform peaks. The lighting sequence for the LEDs may depend upon the desired sampling rate for the PPG signal. It may be assumed a uniform Nyquist sampling rate. Also, it can be noted that frequent lighting of the LEDs may result in significant power consumption of the pulse oximeter sensor.

Certain aspects of the present disclosure support exploiting the sparse nature of the PPG signal and making fewer measurements in order to save the sensor power. A Gabor basis may be employed as the transform space consisting of various cosine waves with time support limited by Gaussian window functions at different scales.

Let the original sampled PPG signal be denoted by N-dimensional vector  $x$  and the sparse-domain transform basis be represented by  $N \times N$  matrix  $W$ . The  $(i, j)$  entry of matrix  $W$  may be given as:

$$[W]_{i,j} = \cos\left(\frac{2\pi(i-1)(j-1)}{2N}\right) \times \exp\left(-\frac{(i-1)^2(j-N/2)^2}{wN^2}\right). \quad (1)$$

The term  $w$  from equation (1) may be associated with the width of the Gaussian kernel in the Gabor basis. Each row of the matrix  $W$  may be normalized such that the corresponding  $l_2$ -norm is equal to 1, and the matrix  $W$  may be referred as the sparse-basis. The PPG signal  $x$  may be projected on the sparse-basis to generate the corresponding N-dimensional representation in the Gabor transform space and it may be given as:

$$y = Wx. \quad (2)$$

FIG. 10 illustrates an example of a short segment of a PPG signal and a corresponding representation  $y$  in the Gabor transform space in accordance with certain aspects of the present disclosure. FIG. 10 illustrates the eight-second segment sampled at 125 Hz (i.e., a total of  $N=1000$  samples). It can be observed that the signal  $x$  may be sparse and compressible in the transform domain with about 30 coefficients greater than 0.2 in terms of absolute magnitude. This indicates that most of the PPG signal characteristics may reside in a much lower-dimensional space compared to  $N$  and thus the PPG signal may be compressible.

Therefore, the CS principles may be exploited which allows to make  $K \ll N$  measurements (i.e. to heavily under-sample the original data) and still be able to estimate  $x$  with a high fidelity. If the signal  $x$  is explicitly-sparse with only  $M$  non-zero elements in the transform space, then selecting  $K \geq M \log N/M$  samples at random from  $x$  may provide

sufficient information with a high probability to enable signal reconstruction with zero error.

In real situations, the signal may never be truly sparse and some information content may exist throughout the transform-space. However, the number of significant components with magnitude greater than  $\epsilon$ , where  $\epsilon \ll \max(y)$ , may be much smaller than  $N$ . In FIG. 10, value of  $\epsilon$  is 0.2. This approach may be extended to the case where  $x$  is not explicitly-sparse, and the CS paradigm may still remain valid. However, the reconstruction error may not be exactly equal to zero.

The sensing process for  $x$  may be mathematically expressed. Let  $P$  denote a  $K$ -dimensional vector containing unique entries (for example, chosen at random) with each element bounded between 1 and  $N$ . This may essentially provide  $K$  random locations to select the elements from  $x$ . The seed for random number generation for constructing the vector  $P$  may be generated locally at the sensor or at the receiver. The seed may be based on keys used in security protocols of the communication link. The  $K$ -dimensional measurement vector  $r$ , obtained from  $x$ , may be written as:

$$r = Hx, \quad (3)$$

where  $H$  denotes the  $K \times N$  measurement matrix.

The  $i^{th}$  row of the matrix  $H$  from equation (3) may be an all-zero vector with 1 at the location given by the  $i^{th}$  element of  $P$ . It can be noted that in the CS framework the measurement matrix may be defined as a matrix containing random independent and identically distributed (i.i.d) elements. Such a measurement matrix may be necessary when it is not known a priori that the input signal is sparse in the time domain or in the transform domain.

The matching pursuit (MP) algorithm may be employed for signal reconstruction from the measurement vector  $r$ . The MP technique represents a greedy algorithm that builds up a signal approximation iteratively by making a locally optimal decision. An initialization of the MP algorithm may be given by defining a modified basis  $V = H \cdot W$  of dimension  $K \times N$  such that  $V = [V_1 \dots V_N]$ , where  $V_j$  is the  $j^{th}$  column vector of  $V$ . Then, the residual may be initialized as  $r_0 = r$ , and the approximation  $\hat{y} = 0$  is the same as  $y$  (i.e.,  $N$ ). The iteration counter may be also initialized as  $i = 1$ .

After that, the column vector from  $V$  may be found that maximizes the inner-product of the residual  $r_{i-1}$  onto  $V$ :

$$n_i = \arg \max_{j=1 \dots N} \frac{\langle r_{i-1}, V_j \rangle}{\|V_j\|_{L_2}}. \quad (4)$$

Then, the residual may be updated, and the coefficient vector  $y$  may be estimated as follows:

$$r_i = r_{i-1} - \frac{\langle r_{i-1}, V_{n_i} \rangle}{\|V_{n_i}\|_{L_2}^2} V_{n_i}, \quad (5)$$

$$\hat{y}_{n_i} = \hat{y}_{n_i} + \frac{\langle r_{i-1}, V_{n_i} \rangle}{\|V_{n_i}\|_{L_2}^2}. \quad (6)$$

After that, the iteration counter  $i$  may be incremented, and

$$\Delta_i = \frac{\|r_i\|_{L_2}}{\|r\|_{L_2}}$$

may be defined. If  $i < m$  and  $\Delta_i > \epsilon$ , then the algorithm step defined by equation (4) may be repeated. Otherwise,  $\hat{\Delta} = \Delta_i$

and  $\tilde{i}=i$  and the algorithm may proceed to the step defined by equations (5) and (6). Finally, the original estimates may be obtained as  $\hat{x}=W\hat{y}$ .

The term  $m$  represents the upper-bound on the number of iterations allowed for reconstruction, and the term  $\epsilon$  defines the convergence criterion. Intuition behind the MP algorithm is twofold. At each iteration step, the algorithm may attempt to find the column of  $V$  that may be most strongly correlated with the residual of  $r$ , and then may subtract the contribution of this column vector from  $r$ . This algorithm is greedy in nature because at each step it may estimate the most dominant component of the original signal  $x$  in the projection space  $W$ . It can be also noted that the main complexity of the MP algorithm lies in equation (4) which may cost  $O(K \cdot N)$  arithmetic operations for a single iteration.

Certain aspects of the present disclosure use the gradient-projection based sparse reconstruction (GPSR) approach to obtain a reconstructed signal from the measurement vector  $r$ . This approach may estimate the original signal  $x$  by jointly minimizing a data fidelity term (i.e.  $l_2$  norm of the error) and the  $l_1$ -norm in a transform space (i.e. measure of sparsity) under no constraints. It is proposed in the present disclosure to modify this optimization problem by using a weighted  $l_1$ -norm. The reconstruction algorithm may be given as:

$$\min_x \|Hx - r\|^2 + \tau \sum_{i=1}^N |f_i [W \cdot x]_i|, \quad (7)$$

where  $f$  is a  $N$ -dimensional vector providing the relative importance of coefficients in transform space for computing the measure of sparsity (i.e.,  $l_1$ -norm). The quantity  $\tau$  is a non-negative parameter indicating the relative weight of  $l_2$ -norm and  $l_1$ -norm in the cost function. The terms  $[f]_i$  and  $[W \cdot x]_i$  denote the  $i^{\text{th}}$  element of vectors  $f$  and  $[W \cdot x]_i$ , respectively.

The  $i^{\text{th}}$  element of vector  $f$  may be given by:

$$[f]_i = \frac{1}{[W \cdot \bar{x}]_i + \sigma}, \quad (8)$$

where  $\sigma$  is a small regularizing parameter. The quantity  $\bar{x}$  represents the ensemble mean of the original signal vector  $x$ , and may be estimated by averaging training example vectors. A segment from the MIMIC database may be utilized to estimate  $\bar{x}$ , which can be then excluded from the experimental validations described below.

FIG. 25 illustrates example operations 2500 for under-sampled acquisition at a sensor and reconstruction at a receiver in accordance with certain aspects of the present disclosure. FIG. 28 illustrates example operations 2800 for actuating and de-actuating a light source at the sensor. At 2510, non-uniform sampling instances may be generated at the sensor according to a random seed. At 2520, samples of a signal may be sensed during a plurality of the non-uniform sampling instances. At 2810, the source at the sensor may be actuated, for example, by turning on one or more LEDs during the plurality of the generated non-uniform sampling instances, and the source may be de-actuated, at 2820, between the plurality of the non-uniform sampling instances.

The sensed samples of the signal may be then packetized to obtain at least one packet of the sensed samples, and the obtained at least one packet may be transmitted over a

wireless channel. At 2530, samples of the signal may be received from the sensor at a re-constructor. At 2540, a set of non-uniform sampling instances may be determined at the re-constructor during which signal was sampled at the sensor according to said random seed. In one aspect, the seed for non-uniform sampling sequence may be generated at the re-constructor based on keys used in security protocols of a communication link between the sensor and the re-constructor. In another aspect, the seed for non-uniform sampling sequence may be determined at the sensor and conveyed to the re-constructor (i.e., to the receiver). In yet another aspect, the seed for non-uniform sampling sequence may be determined at the receiver and conveyed to the sensor. At 2550, the signal may be reconstructed from the received samples using the determined non-uniform sampling sequence according to, for example, the modified GPSR algorithm defined by equations (7)-(8).

The non-uniform sampling instances may be synchronized with received samples of the signal for accurate reconstruction of the signal. Information observed during the reconstruction (e.g., at least one of: coefficients related to the reconstructed signal, a number of dropped packets during the transmission, a channel signal-to-noise ratio, or the variables  $\tilde{\Delta}$  and  $\tilde{i}$ ) may be utilized to adapt various sensor parameters (e.g., the USR, the number of measurements  $K$ , the number of transmitted samples of the signal  $N$ , the number of samples of the signal in each transmitted packet  $P$ , and the measurement matrix  $H$ ) by conveying the observed information to the sensor via a feedback mechanism. Then, the non-uniform sampling instances may be adapted at the sensor according to the received feedback information.

Some reconstruction examples generated based on the CS approach are presented in this disclosure. The eight-second segment may be selected from the MIMIC database sampled at 125 Hz (i.e.,  $N=1000$  samples). It can be recalled that the number of CS samples is  $K$  that defines an under-sampling ratio (USR) as  $N/K$ . FIG. 11 illustrates an example for the CS-PPG signal reconstructions obtained for the USR of 10, 20 and 30 with the upper bound on the number of MP iterations  $m$  equal to 500. The curve 1110 represents the uniformly sampled original signal and curves 1120, 1130 and 1140 represent reconstructed signals for values of USR of 10, 20 and 30, respectively. FIG. 27 illustrates an example of the signal sensed at non-uniform sampling instances at the USR of 40. The sampling instances are shown as vertical lines.

It can be observed from FIG. 11 that the signal integrity may be well preserved until the USR of 20, and may start degrading thereafter. However, it can be noted that the signal peak locations may be well preserved even with high USR (i.e., the USR value of 30). In this case, the LED power consumption (as a part of the PPG data acquisition) may be significantly reduced by the factor of USR because the LEDs may be lightened for much smaller duration, specifically for only  $T \cdot f_s / \text{USR}$  seconds instead of  $T \cdot f_s$  seconds.

#### Heart Rate and PPG Reconstructions

It can be recalled from equations (1) and (2) that each element of the coefficient vector  $y$  may approximately represent the strength of a cosine (with specific frequency) in a sampled signal  $x$ . It can be also noted that a PPG signal may be oscillatory in nature with the dominant frequency being proportional to an HR signal. Therefore, the HR signal may be estimated from the CS reconstruction  $\hat{y}$ , which may be obtained via the MP algorithm, as:

$$\hat{HR} = 60 \cdot (n_{max} - 1) \cdot \frac{f_s}{2N} \text{ bpm}, \quad (9)$$

where

$$n_{max} = \arg \max_{j=2 \dots N} [\hat{y}]_j, [\hat{y}]_j$$

is the  $j^{th}$  element of vector  $\hat{y}$ , and bpm represents unit of beats per minute.

It can be noted that the HR estimate given by equation (9) may be an average obtained over the time duration of  $N \cdot f_s$  seconds. Also, the resolution of the estimate may be given by

$$\frac{60 f_s}{2N}$$

bpm, which is equal to 3.75 bpm for  $N=1000$  and  $f_s=125$  Hz. It can be observed that this resolution may be improved with smaller  $N$ , and the choice of  $N=1000$  is arbitrary.

The complexity of the MP algorithm for the HR estimation can be compared with the complexity of PPG reconstruction. It can be considered the example PPG signal segment illustrated in FIG. 10, for which  $n_{max}$  is equal to 23 implying that the estimated HR is 82.5 bpm. Also, it can be recalled that the MP algorithm is greedy in nature which implies that dominant components of the PPG signal in projection space  $W$  may be estimated in the initial iterations. In this case, the two most dominant components may be the DC component and the cosine with frequency corresponding to the HR. Therefore, it can be expected to achieve a reliable estimate of the HR within a few iterations of the MP algorithm, which also suggests that there may be no need to generate an intermediate representation of the complete PPG signal.

On the other hand, it may be required to reconstruct more coefficients in the projection space  $W$  for signal reconstruction task, which may result in significantly more iterations of the MP-based post-processing. It can be noted that  $m$  iterations of the MP algorithm may roughly cost  $O(m \cdot K \cdot N)$  arithmetic operations. Therefore, the HR estimation (e.g., from the CS measurements) may require less computational complexity at the receiver when compared to the PPG signal reconstruction. Also, it can be recalled that the number of CS samples corresponding to the  $N$ -dimensional signal  $x$  may be  $K$ , which defines an under-sampling ratio (USR) as  $N/K$ . With increased USR, it can be expected increased computational complexity at the receiver in order to achieve a specified performance level. This represents a trade-off between a sensor power (fewer measurements at the transmitter) and an aggregator power (more iterations and computation at the receiver).

The performance metrics for the HR estimation and the PPG signal reconstruction can be introduced. For the HR estimation, the metric may be a root-mean-square-error (RMSE) defined as

$$\sqrt{E[\|HR - \hat{HR}\|^2]}.$$

The metric for the PPG reconstruction may be a normalized RMSE defined as

$$\frac{\sqrt{E[\|x - \hat{x}\|^2]}}{\max\{|x|\}}.$$

The term  $E[\bullet]$  denotes the expectation operator with Monte-Carlo averaging over various realizations of the PPG signals  $x$  and different measurement bases  $H$ . The PPG signal realizations  $x$  may be taken from the MIMIC database. The true heart rate may be extracted from the original signal  $x$  as suggested in equation (9). Each signal segment  $x$  may be taken to be 8 seconds long and sampled at 125 Hz.

FIG. 12 illustrates the HR estimation RMSE with respect to a number of iterations  $m$  for the MP-based post-processing for the USR of 10 and 20. It can be observed that the RMSE may decrease with increasing  $m$  as the estimation accuracy improves with increasing number of iterations. Also, the number of iterations required to achieve a specified RMSE may increase with increasing USR. It can be noted that at  $m=50$ , the HR estimation RMSE equals to 1 bpm, which is less than the considered resolution of 3.75 bpm and 4 bpm for USR of 10 and 20, respectively.

Therefore, in order to achieve the HR estimation RMSE of 1 bpm at USR of 10, it may be required roughly on the order of 0.625 million arithmetic operations per second (i.e.,

$$O(m \cdot K \cdot N) \cdot \frac{f_s}{N},$$

where  $f_s=125$  Hz). Similarly, for reconstructing the signal with an  $RMSE \approx 0.1$  at  $USR=10$ , it may be required roughly on the order of 3.875 million arithmetic operations per second (i.e.,

$$\left( \text{i.e., } O(m \cdot K \cdot N + N^2) \cdot \frac{f_s}{N} \right).$$

This suggests that the described estimation approach may be handled by computational resources in current smart phones or PDAs.

FIG. 13 illustrates a normalized reconstruction RMSE with respect to a number of algorithmic iterations  $m$  for the USR of 10 and 20. It can be observed that the RMSE may be reduced with increasing  $m$ . However, it can be noted that the decrease may be gradual with  $m$  as opposed to the HR estimation RMSE. This may be because the reconstruction task may require estimation of a plurality of coefficients in the sparse space  $W$  as opposed to a single dominant component in the case of HR estimation.

Therefore, the receiver complexity may depend upon value of USR, the task of interest and desired performance level. The intermediate representation of the PPG signal (which may require full reconstruction) may not be required for certain tasks, such as the HR estimation task. Furthermore, one could monitor values of  $\hat{\Delta}$  and  $\hat{\tau}$  variables defined in the MP algorithm during reconstruction. This information may be used to modify the value of USR at the sensor side to adapt to signal variations.

#### Cuffless Blood Pressure Estimation

An SBP and a DBP may be estimated using a pulse arrival time (PAT) and a heart rate (HR), where the PAT can be defined as a delay between a quasi-random signal peak in an ECG waveform and a corresponding peak in a PPG wave-

form. FIG. 14 illustrates the definition of PAT and HR based on example ECG and PPG waveforms.

The first step involved in a blood pressure (BP) estimation algorithm may be to segment the ECG and PPG signals such that the peaks and other points of interest may be extracted from the signals. The second step may be to estimate the BP from the PAT and from the HR.

The ECG segmentation may be accomplished by applying a band-pass filter between 8 Hz and 15 Hz, followed by squaring and then processing in segments of variable duration. The initial segment duration may be 2 seconds. For every segment, a threshold may be computed and all peaks above the threshold may be located. Then, all peaks less than 0.17 seconds apart may be removed, always maintaining the peak with the highest amplitude. In order to segment the PPG signal, the segment between two consecutive ECG peaks may be analyzed. The peaks and valleys may be detected by finding maximum and minimum points within each segment. In order to provide reliable PAT and HR estimates at any instant, signal peaks in the vicinity may also need to be reliable.

The BP estimation model may be stated as follows:

$$SBP = a_1 \cdot PAT + b_1 \cdot HR + c_1,$$

$$DBP = a_2 \cdot PAT + b_2 \cdot HR + c_2, \quad (10)$$

where calibration parameters  $a_i$ ,  $b_i$  and  $c_i$ ,  $i=1,2$  may be estimated during training process and adapted through recursive least squares (RLS) algorithm at every re-calibration opportunity.

In one aspect of the present disclosure, the recalibration may be performed once every one hour. Recalibration duration may essentially imply how often it may be required to estimate or adapt the model parameters. The recalibration step may be required for real applications in order to tackle with bias and drift issues. It may be desired that the re-calibration period is long, so that a blood pressure may be measured continuously and non-invasively in a cuff-less manner for longer periods of time. More frequent recalibrations may reduce the BP estimation error whereas less frequent recalibrations may make the system more amenable for everyday use.

The results of BP estimation using the CS-PPG are presented and compared with those using Nyquist-PPG. For example, records corresponding to 13 patients from the MIMIC database can be used for this evaluation, where length of the records is on average of the order of 38 hours. The gradient projection based sparse reconstruction (GPSR) approach may be used to generate CS-PPG for the entire patient record.

FIG. 15 illustrates the BP estimation results based on the use of ECG and CS-PPG signals of the proposed approach. The value of USR can be taken to be 40 for the CS framework-based measurement of the PPG signal. It may be important from the BP monitoring perspective to compute the frequency of reporting/generating BP estimates. The term  $N_{BP}$  can be introduced as the average number of BP estimates generated per minute using the CS-PPG and the Nyquist-PPG baseline algorithm.

FIG. 15 also illustrates the standard deviation of the SBP and DBP estimation error, as well as  $N_{BP}$  for the Nyquist-PPG and for the CS-PPG with USR of 40. The Association for the Advancement of Medical Instrumentation (AAMI) requirements for BP estimation indicates that the standard deviation of the error has to be below 8 mmHg, both for the SBP and the DBP. It can be observed from FIG. 15 that the average standard deviation for both SBP and DBP estima-

tion error may be less than 8 mmHg. Furthermore, the accuracy does not degrade by using the CS-PPG when compared to the Nyquist-PPG. In this exemplary simulation, an average of 8.85 BP measurements per minute may be estimated at USR of 40, compared with an average of 51 BP estimates per minute using Nyquist-PPG.

The CS-based low power solution is proposed in the present disclosure for acquiring the PPG signals, while the HR and the BP estimation accuracy may not be compromised using the proposed CS-PPG approach. It is also demonstrated that the entire PPG signal may be reconstructed with arbitrarily fine resolution, provided that at least  $K \geq M \log N/M$  samples are acquired and an adequate computational resources are available at the receiver.

### Compressed Sensing Based Packet-Loss Concealment

The issue of packet losses due to poor channel conditions, congestion and mobility between a sender and a receiver is addressed in this disclosure. It can be particularly interesting to exploit the sparse nature of biomedical signals (i.e., PPG signals, ECG signals, etc.) in order to improve robustness against packet losses in a communication link. When a signal being transmitted over the air is sparse in nature (i.e., it has redundancies), then packet-losses may be loosely treated as compression performed by a channel.

Certain aspects of the present disclosure support a CS-based approach to lower the power consumption and to achieve robust communication of the ECG signals in telemedicine. It can be observed that the ECG signals may be less sparse in the Fourier/Gabor space compared to the PPG signals. As illustrated in FIG. 17, there may be many components within the 0.05 Hz to 40 Hz band, which may be considered clinically relevant for the ECG signals. The CS-based PLC approach proposed in the present disclosure may also be completely applicable to the PPG and other signals, provided at least  $K \geq M \log N/M$  measurements are available at the receiver for reconstruction.

It can be assumed that data may be wirelessly transmitted in the form of packets from the sender (i.e., sensor) to the receiver (i.e., aggregator). Following traditional terminology, each packet may contain a Service Data Unit (SDU) and an Application Data Unit (ADU). The ADUs may contain the ECG payload of the application layer, and payload may be defined to contain P ECG samples with typical bit resolution of 8 to 12 bits. It can be assumed that SDUs with channel errors may be dropped in the lower layers, and locations of lost packets may be identified at the application layer via the sequence number field in headers of correctly received packets.

Data may not be transmitted in the form of raw ECG samples. Instead, application layer preceding may be performed on the data. The idea is to pre-code the original ECG signal before transmission by using the random measurement matrix  $H$  defined in equation (3). The resulting pre-coded data may be used to form  $n > 1$  (i.e., multiple) packets which may be then transmitted to the receiver in sequential order. This operation may ensure that it may be possible to infer some information about the original signal in the case of packet losses. The CS-based reconstruction principle may be applied to the received data in order to obtain the ECG signal estimate, the HR estimate, etc. This process may be analogous to convolutional encoding where each information bit to be transmitted is spread over a longer duration defined as a constraint length. The number of samples in

each ADU is denoted by  $P$ . The ECG signals may be taken from the MIMIC database and the sampling rate may be  $f_s=125$  Hz.

FIG. 16 illustrates example operations 1600 for CS-based packet loss concealment (PLC) in accordance with certain aspects of the present disclosure. Operations 1610-1640 may be performed at a sender (e.g., a biomedical sensor, such as a PPG sensor and an ECG sensor), and operations 1650-1670 may be performed at a receiver (e.g., a mobile handset or a PDA).

At 1610, samples of a monitored biomedical signal may be acquired. For example, a vector  $x$  comprising of the  $N$  consecutive ECG samples, where  $N=n \cdot P$  may be generated. After that, a measurement matrix  $H$  of dimension  $K \times N$  may be created. In one aspect, the elements of the matrix  $H$  may be independently chosen from the symmetric Bernoulli distribution  $\Pr(H_{i,j} = -1 \text{ or } 1) = 1/2$ . In another aspect, rows of the measurement matrix may be randomly chosen from  $2^K$  Walsh sequences. In yet another aspect, rows of the measurement matrix may be randomly chosen from the Haar matrix of size  $N \times N$ .

At 1620, the acquired samples of the monitored biomedical signal may be optionally processed to obtain a processed signal of interest. For example, as illustrated in FIG. 14, the ECG and PPG signals may be utilized to obtain a pulse arrival time (PAT) and a heart rate (HR) variability, as well as to obtain an oxygen content in blood. The HR variability and the PAT may be further used to compute a blood pressure, as defined by equation (10). At 1630, either the original signal  $x$  (e.g., the ECG signal and the PPG signal) or the processed signal (e.g., the PAT, the HR variability, the oxygen content, etc) may be precoded using the measurement matrix to obtain a precoded signal.

At 1640, the precoded signal may be packetized to obtain at least one packet of the precoded signal. For example,  $K$  precoded samples may be packed into  $n=K/P$  packets before transmission. If the channel were to drop some packets, then the underlying transform-domain sparsity of the monitored biomedical signal may be used to reconstruct the original signal from the correctly received precoded data packets. It can be noted that the reconstruction fidelity may depend upon the packet loss rate and the signal sparsity structure. At 1650, the at least one packet of the precoded signal may be transmitted over a wireless channel. Because  $N$  samples may be precoded and transmitted, a constant end-to-end latency of  $N/f_s$

$$\left( \frac{n \cdot P}{f_s} \right)$$

seconds may be introduced in the system. The parameter  $K$  may be set to  $N$  (i.e., to  $n \cdot P$ ). It can be recalled that for the PPG acquisition, the parameter  $K$  may be set much smaller than  $N$  and leverage sparsity in order to save an acquisition power.

At 1660, the at least one packet transmitted over the wireless channel may be received at an aggregator. At 1670, indices of packets that are corrupted or lost during transmission may be identified. These indices may be then used to reconstruct original samples of the transmitted signal, at 1680.

The sensor may utilize a random seed to generate a sequence of non-uniform sampling instances. This random seed may be communicated to the receiver, so that the sequence of sampling instances may be re-generated and

used during the reconstruction. On the other hand, the receiver may choose a random seed based on keys used in secure communication. In this case, the receiver may inform the sensor which random seed to use, so that identical sequences of sampling instances may be employed at both sensor and receiver.

Let the wireless channel be represented by a diagonal matrix  $H_c$  of dimension  $K \times K$ . Let  $S$  be a set containing indices of packets lost and not available at the application layer for reconstruction. The cardinality of the set  $S$  may represent the number of dropped packets. The elements in the diagonal of  $H_c$  may be defined as follows:

$$[H_c]_{i,i} = \begin{cases} 0 & \text{if } \left[ \frac{i}{P} \right] \in S \\ 1 & \text{otherwise} \end{cases} \quad (11)$$

The pre-multiplication of  $H_c$  with  $r$  may essentially provide the precoded data samples that were successfully received. The resulting vector can be denoted as  $\hat{r}$  and it is given by  $H_c \cdot H \cdot x$ . If the cardinality of set  $S$  is  $n$ , then this may imply that all the packets were dropped during the transmission, and in this case the estimated signal at the receiver may be set to zero. If the cardinality of set  $S$  is zero (i.e.,  $H_c$  is an identity matrix), then this may imply that no packets were dropped. In this case, the ECG signal  $\hat{x}$  may simply be estimated as  $H^H \cdot \hat{r}$ , where  $H^H$  is a pseudo-inverse of  $H$ . If the cardinality of  $S$  is greater than zero and less than  $n$ , then the previously described MP algorithm may be used to obtain the signal estimate  $\hat{x}$  based on the received vector  $\hat{x}$ . It can be noted that the term  $H$  in the MP algorithm may need to be replaced by  $H_c \cdot H$  in this particular case.

The Gabor basis  $W$  defined in equation (1) may be used to enforce sparsity during the CS reconstruction. This particular CS-based PLC scheme may be referred as the CS-PLC. FIG. 15 illustrates an example of a short segment of the ECG signal  $x$  and its corresponding representation  $y$  (i.e.,  $W \cdot x$ ) in the Gabor transform space. The precoded version of  $x$  given by  $r=H \cdot x$  is also illustrated in FIG. 17.

It can be noted that the preceding within the CS-PLC approach may involve  $n \cdot P$  inner-products and each inner-product may require on the order of  $n \cdot P$  arithmetic operations. Therefore, the preceding complexity is on the order of  $O(n^2 \cdot P^2)$ . In order to decrease the precoding complexity, an alternative CS-based PLC approach based on interleaving is also proposed in the present disclosure.

FIG. 18 illustrates example operations 1800 for interleaving based CS-PLC in accordance with certain aspects of the present disclosure. Operations 1810-1850 may be performed at the sender (e.g., the sensor of a biomedical signal, such as the PPG sensor and the ECG sensor). Operations 1860-1890 may be performed at the receiver (e.g., the mobile handset or the PDA).

At 1810, samples of a monitored biomedical signal may be acquired. At 1820, a defined number of the acquired samples may be precoded to obtain a set of precoded samples. At 1830, a sample-level interleaving may be performed over the set of precoded samples to obtain an interleaved signal. At 1840, the interleaved signal may be packetized to obtain at least one packet of the interleaved signal. At 1850, the at least one packet of the interleaved signal may be transmitted over a wireless channel.

At 1860, the at least one packet transmitted over the wireless channel may be received. At 1870, indices of the packets that are corrupted or lost during the transmission

may be identified. These indices may be then used to reconstruct original samples of the transmitted signal. At **1880**, the received signal may be de-interleaved to obtain a de-interleaved signal. Finally, at **1890**, the de-interleaved signal may be processed, for example by using the MP

algorithm, in order to estimate the original samples of the transmitted signal. The main difference as compared to the CS-PLC scheme **1600** illustrated in FIG. **16** is that the preceding may be now performed for P ECG samples instead of n-P samples, which may reduce the preceding complexity by a factor of  $n^2$ . This may be followed by the sample-level interleaving of the precoded data across the length of n-P samples. Although the original ECG data may be precoded over shorter durations as compared to the CS-PLC scheme **1600** from FIG. **16**, the interleaving step **1830** may allow spreading the signal information across a longer duration. The interleaving process may facilitate handling of bursty channel errors (i.e. losing multiple packets in sequence). It can be also noted that the parameters  $USR$ ,  $n$ ,  $K$  and  $H$  may be adapted based on observed values of  $H_c$ ,  $\Delta$  and  $\hat{i}$  at the receiver in order to achieve the optimal trade-off between sensor life and reconstruction fidelity.

The proposed CS-PLC scheme can be compared with retransmission-based approach, where up to  $k-1$  retransmission attempts may be made on packets that are not successfully received at the receiver. Therefore,  $k=1$  indicates that the data may be transmitted only once from the sender, and if a packet is dropped then the corresponding signal locations may be set to zero by the receiver. The retransmission may have a smaller bandwidth penalty compared to forward error correction (FEC), but at the cost of considerable complexity at the sensor as packets may need to be buffered at the sender. Furthermore, the system latency may be large, and it is proportional to a round trip time (RTT). For these reasons, the CS-PLC approach may be preferable over FEC and retransmission-based approaches for low power sensors.

Quantitative comparisons of various PLC schemes discussed above are presented with respect to packet loss rate. The packet loss rate may be an indicator of channel conditions, congestion, etc., and it may represent a rate at which packets get dropped during the transmission. The packet loss rate may be bounded between 0 and 1, where 0 may indicate that the channel is clean and 1 may indicate that the channel is completely unreliable. All the comparisons presented in this disclosure are averaged over 20,000 Monte-Carlo channel realizations.

The performance of the PLC schemes is first evaluated in terms of normalized RMSE defined as

$$\frac{\sqrt{E[|x - \hat{x}|^2]}}{\max\{|x|\}}$$

The term  $E[\cdot]$  denotes the expectation operator with Monte-Carlo averaging over various realizations of ECG signals  $x$  and different channel realizations  $H_c$ . The ECG signal realizations  $x$  may be taken from the MIMIC database sampled at 125 Hz.

FIG. **19** compares the normalized RMSE performance of the CS-PLC scheme for different values of parameter  $n$ . The value of  $K$  is set to 20 samples per packet for each presented quantitative analysis. The considered exemplary values of  $n$  are 5, 10 and 20 corresponding to latencies of 0.8, 1.6 and 2.4 seconds, respectively. It can be observed from FIG. **19** that normalized RMSE may degrade with increasing packet

loss rate. This can be expected because higher packet loss rates may imply reduced amount of reliable data available at the receiver for estimating  $\hat{x}$ . Also, it can be noted that normalized RMSE performance may improve with increasing number of packets  $n$ . With a higher  $n$ , the sparsity may be enforced over a longer ECG signal duration and thus the reconstruction fidelity may be improved.

FIG. **20** illustrates an example signal reconstruction at the receiver when four packets were dropped by the wireless channel. In this particular example  $n$  is set to 15 packets. A curve **2010** represents the original signal. A curve **2020** represents  $k$ -transmit scheme, where  $k=1$  (i.e., single transmission), and a curve **2030** represents the CS-PLC-based signal estimate. There is no packet loss concealment involved in the 1-transmit scheme corresponding to the curve **2020**, i.e., if a packet is lost then zeros may be substituted in the appropriate signal location at the receiver. It can be noted that with 1-transmit scheme two ECG peaks may be lost in this particular example, whereas using the CS-PLC the complete ECG signal may be estimated with a high fidelity. It can be also noted that losing signal content at critical locations may have severe effect on medical applications like the continuous HR monitoring.

FIG. **21** illustrates comparison of the CS-PLC scheme, the CS with interleaving, and retransmission schemes. The curves **2110** and **2120** represent the CS-PLC and "CS and interleaving" schemes, respectively. The value of  $n$  is set to 15 packets. It can be noted that the reconstruction fidelity obtained using the "CS and interleaving" technique may be very comparable to the CS-PLC method. Although the preceding may be performed over smaller signal support (i.e., within each packet) in the "CS and interleaving" scheme, the interleaving process may allow to spread the information over the length of  $N$  samples. The main benefit using the "CS and interleaving" technique may be reduced preceding complexity at the sensor side, which may be typically more power-constrained side. The curve **2130** in FIG. **21** represents the 1-transmit scheme. It can be noted that at moderate packet loss rate of  $10^{-2}$ , 1-transmit method may perform about five times worse in terms of RMSE performance compared to the CS-PLC scheme.

The previously proposed sample-level interleaving may be employed in the 1-transmit scheme. It can be observed that with interleaving, 1-transmit method may perform only 3 times worse compared to the CS-PLC for packet loss rate of  $10^{-2}$  (i.e., plot **2140** vs. plot **2110**). The RMSE performance are presented for different values of  $k$  in the  $k$ -transmit approach with no interleaving. The curves **2150**, **2160**, and **2170** represent cases  $k=2$ , 3 and 4, respectively. It can be observed that with two and three retransmissions, significant improvement in reconstruction RMSE may be achieved. However, this may come at the cost of increased transmission bandwidth, end-to-end system latency and higher protocol complexity at the sensor.

Different PLC schemes presented above can be compared with respect to heart beat detection accuracy. This quantity can be defined as the rate of correctly identifying peaks in the ECG signal. The value of 100% may indicate a perfect beat detection, whereas the value of 0% may indicate no beat detection. According to the AAMI standards, a beat may be considered correctly detected if it lies within 150 ms of the annotated beat index available beforehand from the database.

FIG. **22** illustrates heart beat detection performance comparisons for various PLC schemes in accordance with certain aspects of the present disclosure. The assumed parameters for Monte-Carlo simulations illustrated in FIG. **22** are

the same as for the simulations illustrated in FIG. 21. There are several observations from the simulation results illustrated in FIG. 22. First, the heart beat detection rate may degrade with increasing packet loss rate as expected. Second, the performance may improve for the k-transmit schemes with increasing number of retransmissions k. Again, this may be obtainable at the expense of increased transmission bandwidth and end-to-end system latency. Third, the proposed CS-based PLC schemes (i.e., plots 2210 and 2220) may perform superior than 3-transmit method even at very high packet loss rates. It can be noted that at packet loss rate of 0.5, the CS and interleaving-based PLC method (i.e., plot 2220) may achieve 96% detection accuracy as opposed to the 3-transmit method (i.e., plot 2260), which may achieve 87% detection accuracy. With a single transmission and no interleaving (i.e., plot 2230), the detection accuracy obtained at packet loss rate of 0.5 may be equal to 55%.

FIGS. 23-24 illustrate examples of restored audio signals using the proposed CS-PLC scheme. It can be observed that the CS-PLC scheme may provide sufficiently accurate estimation results for non-biomedical signals.

To summarize, different applications of compressed sensing (CS) are proposed in the present disclosure concerning low power and robust sensors in the body area networks for healthcare and fitness applications. It is demonstrated that pulse oximeter sensor acquisition power may be significantly reduced while not compromising its utility in clinical applications. Specifically, the CS-based acquisition approach is compared with Nyquist sampling using long term data from many subjects in the MIMIC database, and it is shown that the HR and the BP estimation can meet the accepted accuracy criteria.

The CS-based approach may be used to increase the life of sensors at the cost of additional complexity at the receiver. Tradeoffs are presented between under-sampling at the sensor side and the receiver complexity for a given task. For many healthcare and fitness applications in the BAN, the receiver complexity may be well within the capabilities of current mobile handsets and PDA platforms. Applications such as heart rate estimation may not need complete reconstruction and may further reduce the receiver complexity. Finally, the benefits of the CS-based signal processing are presented for robust communication in the presence of packet losses. It is shown that the reconstruction accuracy may degrade gracefully as packet loss rate increases. It can be demonstrated that the ECG signals may be recovered with high fidelity, even in the presence of high packet loss rate conditions. Presented simulations based on the ECG data from the MIMIC database may demonstrate that up to 96% beat-detection accuracy may be maintained even at packet loss rates as high as 0.5.

The various operations of methods described above may be performed by any suitable means capable of performing the corresponding functions. The means may include various hardware and/or software component(s) and/or module(s), including, but not limited to a circuit, an application specific integrate circuit (ASIC), or processor. Generally, where there are operations illustrated in Figures, those operations may have corresponding counterpart means-plus-function components with similar numbering. For example, blocks 1610-1680, 1810-1890, 2510-2550 and 2810-2820, illustrated in FIGS. 16, 18, 25 and 28 correspond to circuit blocks 1610A-1680A, 1810A-1890A, 2510A-2550A and 2810A-2820A illustrated in FIGS. 16A, 18A, 25A and 28A.

As used herein, the term “determining” encompasses a wide variety of actions. For example, “determining” may include calculating, computing, processing, deriving, investigating, looking up (e.g., looking up in a table, a database or another data structure), ascertaining and the like. Also, “determining” may include receiving (e.g., receiving information), accessing (e.g., accessing data in a memory) and the like. Also, “determining” may include resolving, selecting, choosing, establishing and the like.

As used herein, a phrase referring to “at least one of” a list of items refers to any combination of those items, including single members. As an example, “at least one of: a, b, or c” is intended to cover: a, b, c, a-b, a-c, b-c, and a-b-c.

The various operations of methods described above may be performed by any suitable means capable of performing the operations, such as various hardware and/or software component(s), circuits, and/or module(s). Generally, any operations illustrated in the Figures may be performed by corresponding functional means capable of performing the operations.

The various illustrative logical blocks, modules and circuits described in connection with the present disclosure may be implemented or performed with a general purpose processor, a digital signal processor (DSP), an application specific integrated circuit (ASIC), a field programmable gate array signal (FPGA) or other programmable logic device (PLD), discrete gate or transistor logic, discrete hardware components or any combination thereof designed to perform the functions described herein. A general purpose processor may be a microprocessor, but in the alternative, the processor may be any commercially available processor, controller, microcontroller or state machine. A processor may also be implemented as a combination of computing devices, e.g., a combination of a DSP and a microprocessor, a plurality of microprocessors, a plurality of DSP cores, one or more microprocessors in conjunction with one or more DSP cores, or any other such configuration.

The steps of a method or algorithm described in connection with the present disclosure may be embodied directly in hardware, in a software module executed by a processor, or in a combination of the two. A software module may reside in any form of storage medium that is known in the art. Some examples of storage media that may be used include random access memory (RAM), read only memory (ROM), flash memory, EPROM memory, EEPROM memory, registers, a hard disk, a removable disk, a CD-ROM and so forth. A software module may comprise a single instruction, or many instructions, and may be distributed over several different code segments, among different programs, and across multiple storage media. A storage medium may be coupled to a processor such that the processor can read information from, and write information to, the storage medium. In the alternative, the storage medium may be integral to the processor.

The methods disclosed herein comprise one or more steps or actions for achieving the described method. The method steps and/or actions may be interchanged with one another without departing from the scope of the claims. In other words, unless a specific order of steps or actions is specified, the order and/or use of specific steps and/or actions may be modified without departing from the scope of the claims.

The functions described may be implemented in hardware, software, firmware or any combination thereof. If implemented in software, the functions may be stored as one or more instructions on a computer-readable medium. A storage media may be any available media that can be accessed by a computer. By way of example, and not

limitation, such computer-readable media can comprise RAM, ROM, EEPROM, CD-ROM or other optical disk storage, magnetic disk storage or other magnetic storage devices, or any other medium that can be used to carry or store desired program code in the form of instructions or data structures and that can be accessed by a computer. Disk and disc, as used herein, include compact disc (CD), laser disc, optical disc, digital versatile disc (DVD), floppy disk, and Blu-ray® disc where disks usually reproduce data magnetically, while discs reproduce data optically with lasers.

Thus, certain aspects may comprise a computer program product for performing the operations presented herein. For example, such a computer program product may comprise a computer readable medium having instructions stored (and/or encoded) thereon, the instructions being executable by one or more processors to perform the operations described herein. For certain aspects, the computer program product may include packaging material.

Software or instructions may also be transmitted over a transmission medium. For example, if the software is transmitted from a website, server, or other remote source using a coaxial cable, fiber optic cable, twisted pair, digital subscriber line (DSL), or wireless technologies such as infrared, radio, and microwave, then the coaxial cable, fiber optic cable, twisted pair, DSL, or wireless technologies such as infrared, radio, and microwave are included in the definition of transmission medium.

Further, it should be appreciated that modules and/or other appropriate means for performing the methods and techniques described herein can be downloaded and/or otherwise obtained by an access terminal and/or access point as applicable. For example, such a device can be coupled to a server to facilitate the transfer of means for performing the methods described herein. Alternatively, various methods described herein can be provided via storage means (e.g., RAM, ROM, a physical storage medium such as a compact disc (CD) or floppy disk, etc.), such that an access terminal and/or access point can obtain the various methods upon coupling or providing the storage means to the device. Moreover, any other suitable technique for providing the methods and techniques described herein to a device can be utilized.

It is to be understood that the claims are not limited to the precise configuration and components illustrated above. Various modifications, changes and variations may be made in the arrangement, operation and details of the methods and apparatus described above without departing from the scope of the claims.

A wireless device in the present disclosure may include various components that perform functions based on signals that are transmitted by or received at the wireless device. A wireless device may also refer to a wearable wireless device. In some aspects the wearable wireless device may comprise a wireless headset or a wireless watch. For example, a wireless headset may include a transducer adapted to provide audio output based on data received via a receiver. A wireless watch may include a user interface adapted to provide an indication based on data received via a receiver. A wireless sensing device may include a sensor adapted to provide data to be transmitted via a transmitter.

A wireless device may communicate via one or more wireless communication links that are based on or otherwise support any suitable wireless communication technology. For example, in some aspects a wireless device may associate with a network. In some aspects the network may comprise a personal area network (e.g., supporting a wire-

less coverage area on the order of 30 meters) or a body area network (e.g., supporting a wireless coverage area on the order of 10 meters) implemented using ultra-wideband technology or some other suitable technology. In some aspects the network may comprise a local area network or a wide area network. A wireless device may support or otherwise use one or more of a variety of wireless communication technologies, protocols, or standards such as, for example, CDMA, TDMA, OFDM, OFDMA, WiMAX, and Wi-Fi. Similarly, a wireless device may support or otherwise use one or more of a variety of corresponding modulation or multiplexing schemes. A wireless device may thus include appropriate components (e.g., air interfaces) to establish and communicate via one or more wireless communication links using the above or other wireless communication technologies. For example, a device may comprise a wireless transceiver with associated transmitter and receiver components (e.g., transmitter 210 or 302 and receiver 212 or 304) that may include various components (e.g., signal generators and signal processors) that facilitate communication over a wireless medium.

The teachings herein may be incorporated into (e.g., implemented within or performed by) a variety of apparatuses (e.g., devices). For example, one or more aspects taught herein may be incorporated into a phone (e.g., a cellular phone), a personal data assistant (“PDA”) or so-called smartphone, an entertainment device (e.g., a portable media device, including music and video players), a headset (e.g., headphones, an earpiece, etc.), a microphone, a medical sensing device (e.g., a biometric sensor, a heart rate monitor, a pedometer, an EKG device, a smart bandage, etc.), a user I/O device (e.g., a watch, a remote control, a light switch, a keyboard, a mouse, etc.), an environment sensing device (e.g., a tire pressure monitor), a monitoring device that may receive data from the medical or environment sensing device (e.g., a desktop, a mobile computer, etc.), a point-of-care device, a hearing aid, a set-top box, or any other suitable device. The monitoring device may also have access to data from different sensing devices via connection with a network.

These devices may have different power and data requirements. In some aspects, the teachings herein may be adapted for use in low power applications (e.g., through the use of an impulse-based signaling scheme and low duty cycle modes) and may support a variety of data rates including relatively high data rates (e.g., through the use of high-bandwidth pulses).

In some aspects a wireless device may comprise an access device (e.g., an access point) for a communication system. Such an access device may provide, for example, connectivity to another network (e.g., a wide area network such as the Internet or a cellular network) via a wired or wireless communication link. Accordingly, the access device may enable another device (e.g., a wireless station) to access the other network or some other functionality. In addition, it should be appreciated that one or both of the devices may be portable or, in some cases, relatively non-portable. Also, it should be appreciated that a wireless device also may be capable of transmitting and/or receiving information in a non-wireless manner (e.g., via a wired connection) via an appropriate communication interface.

The invention claimed is:

1. A method for signal processing, comprising:
  - generating, using an apparatus, a plurality of sampling times with non-uniform time intervals between adjacent sampling times;

representing, using the apparatus, the plurality of sampling times with non-uniform time intervals between adjacent sampling times with a measurement matrix; directing, using the apparatus, bursts of energy at a biological tissue during the plurality of sampling times with non-uniform time intervals between adjacent sampling times; sensing, using the apparatus, samples of a signal, formed at the biological tissue in response to the bursts of energy, during the plurality of sampling times with non-uniform time intervals between adjacent sampling times; and precoding, using the apparatus, at least some of the sensed samples using the measurement matrix.

2. The method of claim 1, further comprising:  
 actuating a source of the bursts of energy, using the apparatus, during the plurality of sampling times with non-uniform time intervals between adjacent sampling times; and de-actuating the source, using the apparatus, between the plurality of sampling times with non-uniform time intervals between adjacent sampling times.

3. The method of claim 2, wherein actuating the source comprises turning on one or more light-emitting diodes (LEDs) during the plurality of sampling times with non-uniform time intervals between adjacent sampling times.

4. The method of claim 3, wherein the one or more LEDs emit the bursts of energy in a form of light with a wavelength ranging from 600 nm to 1000 nm.

5. The method of claim 1, wherein generating the sampling times with non-uniform time intervals between adjacent sampling times comprises generating the sampling times with non-uniform time intervals between adjacent sampling times according to a seed.

6. The method of claim 5, wherein the sampling times with non-uniform time intervals between adjacent sampling times are used for sensing samples of the signal and for reconstruction of the signal by another apparatus.

7. The method of claim 6, wherein the seed is generated based on keys used in security protocols of a communication link between the apparatus and the other apparatus.

8. The method of claim 1, further comprising:  
 packetizing, using the apparatus, the precoded samples of the signal to obtain at least one packet of the precoded samples; and transmitting, using the apparatus, the at least one packet over a wireless channel.

9. The method of claim 1, further comprising:  
 receiving, using the apparatus, feedback information about the sampling times with non-uniform time intervals between adjacent sampling times; and generating a seed, using the apparatus, according to the received feedback information, wherein the sampling times with non-uniform time intervals between adjacent sampling times are generated according to the seed.

10. The method of claim 9, wherein the received feedback information comprises coefficients related to reconstruction of the signal.

11. The method of claim 1, wherein the signal comprises a photoplethysmograph (PPG) signal or an electro-cardiogram (ECG) signal.

12. The method of claim 1, wherein the sensing of the samples of the signal formed at the biological tissue is performed in a compressed sensing manner.

13. An apparatus for signal processing, comprising:  
 means for generating a plurality of sampling times with non-uniform time intervals between adjacent sampling times;  
 means for representing the plurality of sampling times with non-uniform time intervals between adjacent sampling times with a measurement matrix;  
 means for directing bursts of energy at a biological tissue during the plurality of sampling times with non-uniform time intervals between adjacent sampling times;  
 means for sensing samples of a signal, formed at the biological tissue in response to the bursts of energy, during the plurality of sampling times with non-uniform time intervals between adjacent sampling times; and  
 means for precoding at least some of the sensed samples using the measurement matrix.

14. The apparatus of claim 13, wherein the means for directing comprises a source of the bursts of energy, and further comprising:  
 means for actuating and de-actuating the source, wherein the means for actuating and de-actuating is configured to actuate the source during the plurality of sampling times with non-uniform time intervals between adjacent sampling times and de-actuate the source between the plurality of sampling times with non-uniform time intervals between adjacent sampling times.

15. The apparatus of claim 14, wherein the source comprises one or more light-emitting diodes (LEDs), and wherein the means for actuating and de-actuating the source comprises means for turning on the one or more LEDs during the plurality of sampling times with non-uniform time intervals between adjacent sampling times.

16. The apparatus of claim 15, wherein the one or more LEDs emit the bursts of energy in a form of light with a wavelength ranging from 600 nm to 1000 nm.

17. The apparatus of claim 13, wherein the means for generating the sampling times with non-uniform time intervals between adjacent sampling times comprises means for generating the sampling times with non-uniform time intervals between adjacent sampling times according to a seed.

18. The apparatus of claim 17, wherein the sampling times with non-uniform time intervals between adjacent sampling times are used for sensing samples of the signal and for reconstruction of the signal by another apparatus.

19. The apparatus of claim 18, wherein the seed is generated based on keys used in security protocols of a communication link between the apparatus and the other apparatus.

20. The apparatus of claim 13, further comprising:  
 means for packetizing the precoded samples of the signal to obtain at least one packet of the precoded samples; and  
 means for transmitting the at least one packet over a wireless channel.

21. The apparatus of claim 13, further comprising:  
 means for receiving feedback information about the sampling times with non-uniform time intervals between adjacent sampling times; and  
 means for generating a seed according to the received feedback information, wherein the sampling times with non-uniform time intervals between adjacent sampling times are generated according to the seed.

22. The apparatus of claim 21, wherein the received feedback information comprises coefficients related to reconstruction of the signal.

23. The apparatus of claim 13, wherein the signal comprises a photoplethysmograph (PPG) signal or an electrocardiogram (ECG) signal.

24. A computer-program product for signal processing, comprising a non-transitory computer-readable storage medium encoded with instructions executable by a processor to:

- generate a plurality of sampling times with non-uniform time intervals between adjacent sampling times;
- represent the plurality of sampling times with non-uniform time intervals between adjacent sampling times with a measurement matrix;
- direct bursts of energy at a biological tissue during the sampling times with non-uniform time intervals between adjacent sampling times;
- sense samples of a signal, formed at the biological tissue in response to the bursts of energy, during the plurality of sampling times with non-uniform time intervals between adjacent sampling times; and
- precode at least some of the sensed samples using the measurement matrix.

25. A sensing device, comprising:

- a generator configured to generate a plurality of sampling times with non-uniform time intervals between adjacent sampling times;
- a constructor configured to represent the plurality of sampling times with non-uniform time intervals between adjacent sampling times with a measurement matrix;
- a source configured to direct bursts of energy at a biological tissue during the plurality of sampling times with non-uniform time intervals between adjacent sampling times;
- a sensor configured to sense samples of a signal, formed at the biological tissue in response to the bursts of energy, during the plurality of sampling times with non-uniform time intervals between adjacent sampling times;
- a precoder configured to precode at least some of the sensed samples using the measurement matrix; and
- a transmitter configured to transmit the precoded samples.

26. A method for signal processing, comprising:

- actuating, using an apparatus, a source during a plurality of sampling times with non-uniform time intervals between adjacent sampling times, wherein, in response to the actuation, the source directs bursts of energy at a biological tissue during the sampling times with non-uniform time intervals between adjacent sampling times; and
- de-actuating, using the apparatus, the source between the plurality of sampling times with non-uniform time intervals between adjacent sampling times, the plurality of sampling times with non-uniform time intervals between adjacent sampling times being generated at least in part from comparing an actual signal with a target signal to update an under-sampling ratio.

27. The method of claim 26, wherein actuating the source comprises turning on one or more light-emitting diodes (LEDs) during the plurality of sampling times with non-uniform time intervals between adjacent sampling times.

28. The method of claim 27, wherein the one or more LEDs emit the bursts of energy in a form of light with a wavelength ranging from 600 nm to 1000 nm.

29. An apparatus for signal processing, comprising: means for generating a plurality of sampling times with non-uniform time intervals between adjacent sampling times at least in part from comparing an actual signal with a target signal to update an under-sampling ratio; and

means for actuating and de-actuating a source, wherein the means for actuating and de-actuating the source is configured to actuate the source during the plurality of sampling times with non-uniform time intervals between adjacent sampling times and de-actuate the source between the plurality of sampling times with non-uniform time intervals between adjacent sampling times, wherein, in response to the actuation, the source is configured to direct bursts of energy at a biological tissue during the sampling times with non-uniform time intervals between adjacent sampling times.

30. The apparatus of claim 29, wherein the source comprises one or more light-emitting diodes (LEDs), and wherein the means for actuating and de-actuating the source comprises means for turning on the one or more LEDs during the plurality of sampling times with non-uniform time intervals between adjacent sampling times.

31. The apparatus of claim 30, wherein the one or more LEDs emit the bursts of energy in a form of light with a wavelength ranging from 600 nm to 1000 nm.

32. A computer-program product for signal processing, comprising a non-transitory computer-readable storage medium encoded with instructions executable by a processor to:

- generate a plurality of sampling times with non-uniform time intervals between adjacent sampling times at least in part from comparing an actual signal with a target signal to update an under-sampling ratio;
- actuate a source during the plurality of sampling times with non-uniform time intervals between adjacent sampling times wherein, in response to the actuation, the source directs bursts of energy at a biological tissue during the sampling times with non-uniform time intervals between adjacent sampling times; and
- de-actuate the source between the plurality of sampling times with non-uniform time intervals between adjacent sampling times.

33. A sensing device, comprising:

- a circuit configured to:
  - generate a plurality of sampling times with non-uniform time intervals between adjacent sampling times at least in part from comparing an actual signal with a target signal to update an under-sampling ratio;
  - actuate a source at least during the plurality of sampling times with non-uniform time intervals between adjacent sampling times wherein, in response to the actuation, the source is configured to direct bursts of energy at a biological tissue during the plurality of sampling times with non-uniform time intervals between adjacent sampling times; and
  - de-actuate the source at least between the plurality of sampling times with non-uniform time intervals between adjacent sampling times;
- a sensor configured to sense samples of a signal, formed at the biological tissue in response to the bursts of energy, during the plurality of sampling times with non-uniform time intervals between adjacent sampling times.

专利名称(译)	用于采样和采集光电容积描记器 ( PPG ) 数据以及在接收器处重建全频带PPG数据的方法和装置		
公开(公告)号	<a href="#">US10213164</a>	公开(公告)日	2019-02-26
申请号	US12/512480	申请日	2009-07-30
[标]申请(专利权)人(译)	高通股份有限公司		
申请(专利权)人(译)	高通公司		
当前申请(专利权)人(译)	高通公司		
[标]发明人	GARUDADRI HARINATH BAHETI PAWAN KUMAR		
发明人	GARUDADRI, HARINATH BAHETI, PAWAN KUMAR		
IPC分类号	H04B1/00 G06K9/00 G01R13/02 A61B5/00 H03M7/30 A61B5/1455 A61B5/021		
CPC分类号	H03M7/30 G01R13/0272 A61B5/7232 A61B5/0006 A61B5/0024 A61B5/14551 G06K9/00496 A61B5/021 A61B2560/0209		
代理机构(译)	KILPATRICK TOWNSEND & STOCKTON		
优先权	61/101056 2008-09-29 US 61/100654 2008-09-26 US		
其他公开文献	US20100082302A1		
外部链接	<a href="#">Espacenet</a>		

摘要(译)

本公开的某些方面涉及一种用于压缩感测 ( CS ) 的方法。CS是一种信号处理概念，其中可以使用比香农/奈奎斯特采样定理所建议的传感器测量值明显更少的传感器测量来恢复具有任意精细分辨率的信号。在本公开中，CS框架被应用于传感器信号处理，以便支持低功率鲁棒传感器和用于医疗保健和健身应用的体域网 ( BAN ) 中的可靠通信。

