



US009775545B2

(12) **United States Patent**
Al-Ali et al.

(10) **Patent No.:** **US 9,775,545 B2**
(45) **Date of Patent:** **Oct. 3, 2017**

(54) **MAGNETIC ELECTRICAL CONNECTOR FOR PATIENT MONITORS**

(75) Inventors: **Ammar Al-Ali**, San Juan Capistrano, CA (US); **Eric Karl Kinast**, Santa Ana, CA (US)

(73) Assignee: **Masimo Corporation**, Irvine, CA (US)

(*) Notice: Subject to any disclaimer, the term of this patent is extended or adjusted under 35 U.S.C. 154(b) by 347 days.

(21) Appl. No.: **13/246,768**

(22) Filed: **Sep. 27, 2011**

(65) **Prior Publication Data**
US 2012/0088984 A1 Apr. 12, 2012

Related U.S. Application Data
(60) Provisional application No. 61/387,426, filed on Sep. 28, 2010.

(51) **Int. Cl.**
A61B 5/00 (2006.01)
A61B 5/1455 (2006.01)
A61B 5/0476 (2006.01)

(52) **U.S. Cl.**
CPC *A61B 5/14551* (2013.01); *A61B 5/0476* (2013.01); *A61B 5/14553* (2013.01); *A61B 5/6814* (2013.01); *A61B 2562/227* (2013.01); *A61B 2562/245* (2013.01)

(58) **Field of Classification Search**
CPC . A61B 5/0476; A61B 5/0006; A61B 5/04004; A61B 5/0478; A61B 5/14552; A61B 5/6814; A61B 2562/164; A61B 5/04282; A61B 18/1233; A61B 2018/00083; G08C 17/06
USPC 600/300-301
See application file for complete search history.

(56) **References Cited**

U.S. PATENT DOCUMENTS

3,811,094 A *	5/1974	Lee	330/59
4,223,680 A	9/1980	Jobsis	
4,281,645 A	8/1981	Jobsis	
4,321,930 A	3/1982	Jobsis et al.	
4,380,240 A	4/1983	Jobsis et al.	
4,510,938 A	4/1985	Jobsis et al.	
4,796,184 A	1/1989	Bahr et al.	
4,803,997 A	2/1989	Bowman	
4,805,623 A	2/1989	Jobsis	
4,848,345 A *	7/1989	Zenkich	607/2
4,901,238 A	2/1990	Suzuki et al.	

(Continued)

FOREIGN PATENT DOCUMENTS

EP	505491	9/1992
EP	0 541 393	11/1992

(Continued)

OTHER PUBLICATIONS

US 8,845,543, 09/2014, Diab et al. (withdrawn)

(Continued)

Primary Examiner — Adam J Eiseman

Assistant Examiner — Shirley Jian

(74) *Attorney, Agent, or Firm* — Knobbe Martens Olson & Bear, LLP

(57) **ABSTRACT**

The present disclosure relates to an electrical connector for providing signal isolation between various components of a physiological monitoring system. In an embodiment, the electrical connector is placed between a sensor and associated monitoring system and includes a physical barrier and inductive components.

5 Claims, 14 Drawing Sheets

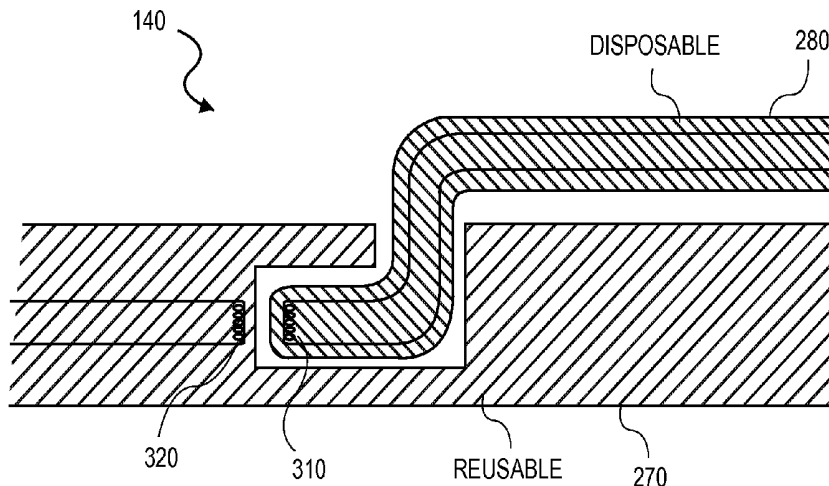

(56)

References Cited

U.S. PATENT DOCUMENTS

4,907,876 A	3/1990	Suzuki et al.	5,477,051 A	12/1995	Tsuchiya
4,908,762 A	3/1990	Suzuki et al.	5,479,934 A	1/1996	Imran
4,917,116 A	4/1990	LaViola et al.	5,482,036 A	1/1996	Diab et al.
4,928,696 A	5/1990	Henderson et al.	5,490,505 A	2/1996	Diab et al.
4,938,218 A	7/1990	Goodman et al.	5,492,118 A	2/1996	Gratton et al.
4,957,000 A	9/1990	Delpy et al.	5,494,043 A	2/1996	O'Sullivan et al.
4,960,128 A	10/1990	Gordon et al.	5,497,769 A	3/1996	Gratton et al.
4,964,408 A	10/1990	Hink et al.	5,497,772 A *	3/1996	Schulman A61B 5/14865 204/403.09
4,967,038 A	10/1990	Gevins et al.	5,511,552 A	4/1996	Johnson
4,972,331 A	11/1990	Chance	5,517,987 A	5/1996	Tsuchiya
4,996,992 A	3/1991	LaViola et al.	5,520,176 A	5/1996	Cohen
5,022,403 A	6/1991	LaViola	5,520,683 A	5/1996	Subramaniam et al.
5,032,024 A	7/1991	Cope	5,529,065 A	6/1996	Tsuchiya
5,038,782 A	8/1991	Gevins et al.	5,533,511 A	7/1996	Kaspari et al.
5,041,187 A	8/1991	Hink et al.	5,534,851 A	7/1996	Russek
5,069,213 A	12/1991	Polczynski	5,540,722 A	7/1996	Clare et al.
5,090,415 A	2/1992	Yamashita et al.	5,553,614 A	9/1996	Chance
5,099,842 A	3/1992	Mannheimer et al.	5,561,275 A	10/1996	Savage et al.
5,101,830 A	4/1992	Duffy et al.	5,562,002 A	10/1996	Lalin
5,103,829 A	4/1992	Suzuki et al.	5,564,417 A	10/1996	Chance
5,109,849 A	5/1992	Goodman et al.	5,564,418 A	10/1996	Ozaki et al.
5,119,815 A	6/1992	Chance	5,582,169 A	12/1996	Oda et al.
5,122,974 A	6/1992	Chance	5,590,649 A	1/1997	Caro et al.
5,154,180 A	10/1992	Blanchet et al.	5,596,038 A	1/1997	Subramaniam
5,163,438 A	11/1992	Gordon et al.	5,596,987 A	1/1997	Chance
5,179,570 A	1/1993	Imran	5,602,924 A	2/1997	Durand et al.
5,179,957 A	1/1993	Williams	5,605,157 A	2/1997	Panescu et al.
5,181,520 A	1/1993	Wertheim et al.	5,626,145 A	5/1997	Clapp et al.
5,187,672 A	2/1993	Chance et al.	5,632,272 A	5/1997	Diab et al.
5,195,531 A	3/1993	Bennett	5,638,816 A	6/1997	Kiani-Azarbayjany et al.
5,211,174 A	5/1993	Imran	5,638,818 A	6/1997	Diab et al.
5,213,105 A	5/1993	Gratton et al.	5,640,247 A	6/1997	Tsuchiya et al.
5,218,962 A	6/1993	Mannheimer et al.	5,645,440 A	7/1997	Tobler et al.
5,220,502 A	6/1993	Qian et al.	5,664,574 A	9/1997	Chance
5,226,417 A	7/1993	Swedlow et al.	5,673,701 A	10/1997	Chance
5,228,440 A	7/1993	Chung et al.	5,676,142 A	10/1997	Miwa et al.
5,247,932 A	9/1993	Chung et al.	5,678,558 A	10/1997	Johnson
5,253,646 A	10/1993	Delpy et al.	5,678,560 A	10/1997	Sakamoto et al.
5,280,793 A	1/1994	Rosenfeld	5,685,299 A	11/1997	Diab et al.
5,289,822 A	3/1994	Highe et al.	5,686,516 A	11/1997	Tzur
5,295,482 A	3/1994	Clare et al.	5,694,931 A	12/1997	Tsuchiya
5,299,118 A	3/1994	Martens et al.	5,706,821 A	1/1998	Matcher et al.
5,299,822 A	4/1994	Mayr et al.	5,727,547 A	3/1998	Levinson et al.
5,307,818 A *	5/1994	Segalowitz 600/509	D393,830 S	4/1998	Tobler et al.
5,319,355 A	6/1994	Russek	5,743,260 A	4/1998	Chung et al.
5,327,888 A	7/1994	Imran	5,743,262 A	4/1998	Lepper, Jr. et al.
5,331,959 A	7/1994	Imran	5,746,210 A	5/1998	Benaron et al.
5,337,744 A	8/1994	Branigan	5,752,519 A	5/1998	Benaron et al.
5,337,745 A	8/1994	Benaron	5,752,914 A	5/1998	Delonzor et al.
5,341,805 A	8/1994	Stavridi et al.	5,758,644 A	6/1998	Diab et al.
5,345,934 A	9/1994	Highe et al.	5,760,910 A	6/1998	Lepper, Jr. et al.
5,353,799 A	10/1994	Chance	5,769,785 A	6/1998	Diab et al.
5,361,773 A	11/1994	Ives	5,772,587 A	6/1998	Gratton et al.
D353,195 S	12/1994	Savage et al.	5,772,588 A	6/1998	Miwa et al.
D353,196 S	12/1994	Savage et al.	5,775,330 A	7/1998	Kangas et al.
5,377,674 A	1/1995	Kuestner	5,776,058 A	7/1998	Levinson et al.
5,377,675 A	1/1995	Ruskewicz et al.	5,779,631 A	7/1998	Chance
5,377,676 A	1/1995	Vari et al.	5,782,237 A	7/1998	Casciani et al.
5,386,827 A	2/1995	Chance et al.	5,782,756 A	7/1998	Mannheimer
5,402,778 A	4/1995	Chance	5,782,757 A	7/1998	Diab et al.
5,406,957 A	4/1995	Tansey	5,785,658 A	7/1998	Benaron et al.
5,413,098 A	5/1995	Benaron	5,785,659 A	7/1998	Caro et al.
D359,546 S	6/1995	Savage et al.	5,791,347 A	8/1998	Flaherty et al.
5,421,329 A	6/1995	Casciani et al.	5,807,261 A	9/1998	Benaron et al.
5,424,843 A	6/1995	Tromberg et al.	5,807,263 A	9/1998	Chance
5,431,170 A	7/1995	Mathews	5,810,734 A	9/1998	Caro et al.
D361,840 S	8/1995	Savage et al.	5,813,980 A	9/1998	Levinson et al.
5,441,054 A	8/1995	Tsuchiya	5,813,993 A	9/1998	Kaplan et al.
D362,063 S	9/1995	Savage et al.	5,816,247 A	10/1998	Maynard
5,450,855 A	9/1995	Rosenfeld et al.	5,820,558 A	10/1998	Chance
5,452,717 A	9/1995	Branigan et al.	5,823,950 A	10/1998	Diab et al.
5,452,718 A	9/1995	Clare et al.	5,823,952 A	10/1998	Levinson et al.
D363,120 S	10/1995	Savage et al.	5,830,131 A	11/1998	Caro et al.
5,456,252 A	10/1995	Vari et al.	5,833,618 A	11/1998	Caro et al.
5,458,117 A	10/1995	Chamoun et al.	5,846,208 A	12/1998	Pichlmayr et al.
			5,851,179 A	12/1998	Ritson et al.
			5,853,370 A	12/1998	Chance et al.
			RE36,044 E	1/1999	Benaron

(56)

References Cited

U.S. PATENT DOCUMENTS

5,857,979	A	1/1999	Ryu et al.	6,321,100	B1	11/2001	Parker
5,860,919	A	1/1999	Kiani-Azarbayjany et al.	6,325,761	B1	12/2001	Jay
5,865,736	A	2/1999	Baker, Jr. et al.	6,334,065	B1	12/2001	Al-Ali et al.
5,873,821	A	2/1999	Chance et al.	6,335,792	B1	1/2002	Tsuchiya
5,879,294	A	3/1999	Anderson et al.	6,343,224	B1	1/2002	Parker
5,890,929	A	4/1999	Mills et al.	6,343,229	B1	1/2002	Siebler et al.
5,904,654	A	5/1999	Wohltmann et al.	6,349,228	B1	2/2002	Kiani et al.
5,917,190	A	6/1999	Yodh et al.	6,360,114	B1	3/2002	Diab et al.
5,919,134	A	7/1999	Diab	6,368,283	B1	4/2002	Xu et al.
5,934,925	A	8/1999	Tobler et al.	6,371,921	B1	4/2002	Caro et al.
5,940,182	A	8/1999	Lepper, Jr. et al.	6,377,829	B1	4/2002	Al-Ali
5,954,053	A	9/1999	Chance et al.	6,377,840	B1	4/2002	Gritsenko et al.
5,983,121	A	11/1999	Tsuchiya	6,385,486	B1*	5/2002	John et al. 600/544
5,987,346	A	11/1999	Benaron et al.	6,388,240	B2	5/2002	Schulz et al.
5,987,351	A	11/1999	Chance	6,397,091	B2	5/2002	Diab et al.
5,995,855	A	11/1999	Kiani et al.	6,397,099	B1	5/2002	Chance
5,997,343	A	12/1999	Mills et al.	6,397,845	B1	6/2002	Burton
5,999,846	A	12/1999	Pardey et al.	6,416,480	B1	7/2002	Nenov
6,002,952	A	12/1999	Diab et al.	6,430,437	B1	8/2002	Marro
6,011,986	A	1/2000	Diab et al.	6,430,525	B1	8/2002	Weber et al.
6,011,990	A	1/2000	Schultz et al.	6,445,955	B1*	9/2002	Michelson et al. 607/46
6,027,452	A	2/2000	Flaherty et al.	6,456,862	B2	9/2002	Benni
6,032,065	A	2/2000	Brown et al.	6,463,310	B1	10/2002	Swedlow et al.
6,035,223	A	3/2000	Baker, Jr.	6,463,311	B1	10/2002	Diab
6,036,642	A	3/2000	Diab et al.	6,470,199	B1	10/2002	Kopotic et al.
6,045,509	A	4/2000	Caro et al.	6,473,632	B1	10/2002	Myers
6,052,619	A*	4/2000	John 600/544	6,481,899	B1	11/2002	Quast et al.
6,058,324	A	5/2000	Chance	6,487,343	B1	11/2002	Lewandowski et al.
6,067,462	A	5/2000	Diab et al.	6,496,724	B1	12/2002	Levendowski et al.
6,067,467	A	5/2000	John	6,497,658	B2	12/2002	Roizen et al.
6,069,975	A	5/2000	Lehmann et al.	6,501,975	B2	12/2002	Diab et al.
6,070,098	A	5/2000	Moore-Ede et al.	6,505,059	B1	1/2003	Kollias et al.
6,075,610	A	6/2000	Ueda et al.	6,511,424	B1	1/2003	Moore-Ede et al.
6,076,010	A	6/2000	Boas et al.	6,515,273	B2	2/2003	Al-Ali
6,078,833	A	6/2000	Hueber	6,516,209	B2	2/2003	Cheng et al.
6,081,735	A	6/2000	Diab et al.	6,516,214	B1	2/2003	Boas
6,088,607	A	7/2000	Diab et al.	6,519,487	B1	2/2003	Parker
6,110,522	A	8/2000	Lepper, Jr. et al.	6,525,386	B1	2/2003	Mills et al.
6,124,597	A	9/2000	Shehada	6,526,300	B1	2/2003	Kiani et al.
6,128,521	A	10/2000	Marro et al.	6,526,309	B1	2/2003	Chance
6,129,675	A	10/2000	Jay	6,537,228	B1	3/2003	Lambert
6,144,868	A	11/2000	Parker	6,541,756	B2	4/2003	Schulz et al.
6,151,516	A	11/2000	Kiani-Azarbayjany et al.	6,542,764	B1	4/2003	Al-Ali et al.
6,152,754	A	11/2000	Gerhardt et al.	6,542,772	B1	4/2003	Chance
6,154,669	A	11/2000	Hunter et al.	6,549,284	B1	4/2003	Boas et al.
6,157,850	A	12/2000	Diab et al.	6,564,076	B1	5/2003	Chance
6,157,857	A	12/2000	Dimpfel	6,567,165	B1	5/2003	Tsuchiya et al.
6,165,005	A	12/2000	Mills et al.	6,575,902	B1	6/2003	Burton
6,184,521	B1	2/2001	Coffin, IV et al.	6,577,884	B1	6/2003	Boas
6,192,260	B1	2/2001	Chance	6,580,086	B1	6/2003	Schulz et al.
6,192,261	B1	2/2001	Gratton et al.	6,584,336	B1	6/2003	Ali et al.
6,206,830	B1	3/2001	Diab et al.	6,587,703	B2	7/2003	Cheng et al.
6,216,021	B1	4/2001	Franceschini et al.	6,591,123	B2	7/2003	Fein et al.
6,229,856	B1	5/2001	Diab et al.	6,594,513	B1	7/2003	Jobsis et al.
6,232,609	B1	5/2001	Snyder et al.	6,594,518	B1	7/2003	Benaron et al.
6,233,470	B1	5/2001	Tsuchiya	6,595,316	B2	7/2003	Cybulski et al.
6,236,871	B1	5/2001	Tsuchiya	6,597,931	B1	7/2003	Cheng et al.
6,236,872	B1	5/2001	Diab et al.	6,597,932	B2	7/2003	Tian et al.
6,236,885	B1	5/2001	Hunter et al.	6,597,933	B2	7/2003	Kiani et al.
6,240,305	B1	5/2001	Tsuchiya	6,599,281	B1	7/2003	Struys et al.
6,241,683	B1	6/2001	Macklem et al.	6,606,511	B1	8/2003	Ali et al.
6,246,892	B1	6/2001	Chance	6,609,024	B1	8/2003	Ryu et al.
6,253,097	B1	6/2001	Aronow et al.	6,618,614	B1	9/2003	Chance
6,256,523	B1	7/2001	Diab et al.	6,631,291	B2	10/2003	Viertio-Oja et al.
6,263,221	B1	7/2001	Chance et al.	6,632,181	B2	10/2003	Flaherty et al.
6,263,222	B1	7/2001	Diab et al.	6,639,668	B1	10/2003	Trepagnier
6,272,363	B1	8/2001	Casciani et al.	6,640,116	B2	10/2003	Diab
6,272,367	B1	8/2001	Chance	6,643,530	B2	11/2003	Diab et al.
6,272,378	B1	8/2001	Baumgart-Schmitt	6,650,917	B2	11/2003	Diab et al.
6,278,522	B1	8/2001	Lepper, Jr. et al.	6,654,624	B2	11/2003	Diab et al.
6,280,213	B1	8/2001	Tobler et al.	6,654,632	B2	11/2003	Lange et al.
6,285,896	B1	9/2001	Tobler et al.	6,658,276	B2	12/2003	Pishney et al.
6,298,252	B1	10/2001	Kovach et al.	6,661,161	B1	12/2003	Lanzo et al.
6,301,493	B1	10/2001	Marro et al.	6,662,033	B2	12/2003	Casciani et al.
6,317,627	B1	11/2001	Ennen et al.	6,665,560	B2	12/2003	Becker et al.
				6,667,803	B1	12/2003	Flessland et al.
				6,671,530	B2	12/2003	Chung et al.
				6,671,531	B2	12/2003	Al-Ali et al.
				6,675,031	B1	1/2004	Porges et al.

(56)

References Cited

U.S. PATENT DOCUMENTS

6,678,543	B2	1/2004	Diab et al.	7,015,451	B2	3/2006	Dalke et al.
6,684,090	B2	1/2004	Ali et al.	7,024,233	B2	4/2006	Ali et al.
6,684,091	B2	1/2004	Parker	7,027,849	B2	4/2006	Al-Ali
6,687,524	B1	2/2004	Svejk	7,030,749	B2	4/2006	Al-Ali
6,697,656	B1	2/2004	Al-Ali	7,035,744	B2	4/2006	Cheriet et al.
6,697,657	B1	2/2004	Shehada et al.	7,039,449	B2	5/2006	Al-Ali
6,697,658	B2	2/2004	Al-Ali	7,041,060	B2	5/2006	Flaherty et al.
RE38,476	E	3/2004	Diab et al.	7,044,918	B2	5/2006	Diab
6,699,194	B1	3/2004	Diab et al.	7,047,054	B2	5/2006	Benni
6,701,170	B2	3/2004	Stetson	7,047,055	B2	5/2006	Boas et al.
6,708,048	B1	3/2004	Chance	7,047,056	B2	5/2006	Hannula et al.
6,708,049	B1	3/2004	Berson et al.	7,054,680	B1	5/2006	Genger et al.
6,711,426	B2	3/2004	Benaron et al.	7,067,893	B2	6/2006	Mills et al.
6,714,804	B2	3/2004	Al-Ali et al.	7,072,701	B2	7/2006	Chen et al.
RE38,492	E	4/2004	Diab et al.	7,085,597	B2	8/2006	Fein et al.
6,721,582	B2	4/2004	Trepagnier et al.	7,092,748	B2	8/2006	Valdes et al.
6,721,585	B1	4/2004	Parker	7,096,052	B2	8/2006	Mason et al.
6,725,075	B2	4/2004	Al-Ali	7,096,054	B2	8/2006	Abdul-Hafiz et al.
6,728,560	B2	4/2004	Kollias et al.	7,132,641	B2	11/2006	Schulz et al.
6,728,564	B2	4/2004	Lahteenmaki	7,139,603	B2	11/2006	Chance
6,731,975	B1	5/2004	Viertio-Oja	7,142,901	B2	11/2006	Kiani et al.
6,735,458	B2	5/2004	Cheng et al.	7,149,561	B2	12/2006	Diab
6,735,459	B2	5/2004	Parker	7,186,966	B2	3/2007	Al-Ali
6,745,060	B2	6/2004	Diab et al.	7,190,261	B2	3/2007	Al-Ali
6,748,259	B1	6/2004	Benaron et al.	7,209,861	B2	4/2007	Hively
6,748,263	B2	6/2004	Griffiths et al.	7,215,984	B2	5/2007	Diab
6,751,499	B2	6/2004	Lange et al.	7,215,986	B2	5/2007	Diab
6,757,558	B2	6/2004	Lange et al.	7,220,240	B2	5/2007	Struys et al.
6,760,607	B2	7/2004	Al-Ali	7,221,971	B2	5/2007	Diab
6,768,920	B2	7/2004	Lange et al.	7,221,975	B2	5/2007	Lindstrom
6,770,028	B1	8/2004	Ali et al.	7,225,006	B2	5/2007	Al-Ali et al.
6,771,994	B2	8/2004	Kiani et al.	7,225,007	B2	5/2007	Al-Ali
6,792,300	B1	9/2004	Diab et al.	7,225,013	B2	5/2007	Geva et al.
6,795,724	B2	9/2004	Hogan	RE39,672	E	6/2007	Shehada et al.
6,801,648	B2	10/2004	Cheng	7,228,169	B2	6/2007	Viertio-Oja
6,801,797	B2	10/2004	Mannheimer et al.	7,229,430	B2	6/2007	Hickle et al.
6,801,803	B2	10/2004	Viertio-Oja	7,231,246	B2	6/2007	Rautee et al.
6,813,511	B2	11/2004	Diab et al.	7,239,385	B2	7/2007	Schmitz et al.
6,816,741	B2	11/2004	Diab	7,239,901	B2	7/2007	Gritsenko
6,822,564	B2	11/2004	Al-Ali	7,239,905	B2	7/2007	Kiani-Azarbayjany et al.
6,826,419	B2	11/2004	Diab et al.	7,239,988	B2	7/2007	Hasson et al.
6,830,047	B2	12/2004	Heitmeier et al.	7,245,953	B1	7/2007	Parker
6,830,711	B2	12/2004	Mills et al.	7,248,909	B2	7/2007	Lee et al.
6,836,502	B2	12/2004	Canady et al.	7,254,429	B2	8/2007	Schurman et al.
6,839,583	B1	1/2005	Lewandowski et al.	7,254,431	B2	8/2007	Al-Ali
6,850,787	B2	2/2005	Weber et al.	7,254,433	B2	8/2007	Diab et al.
6,850,788	B2	2/2005	Al-Ali	7,254,434	B2	8/2007	Schulz et al.
6,852,083	B2	2/2005	Caro et al.	7,254,500	B2	8/2007	Makeig et al.
6,861,639	B2	3/2005	Al-Ali	7,272,425	B2	9/2007	Al-Ali
6,892,006	B2	5/2005	Lewandowski et al.	7,274,955	B2	9/2007	Kiani et al.
6,898,452	B2	5/2005	Al-Ali et al.	D554,263	S	10/2007	Al-Ali et al.
6,907,280	B2	6/2005	Becerra et al.	7,277,741	B2	10/2007	Debreczeny et al.
6,920,345	B2	7/2005	Al-Ali et al.	7,277,831	B1	10/2007	Pawelzik et al.
6,931,268	B1	8/2005	Kiani-Azarbayjany et al.	7,280,858	B2	10/2007	Al-Ali et al.
6,934,570	B2*	8/2005	Kiani et al. 600/324	7,288,066	B2	10/2007	Drew
6,934,579	B2	8/2005	Mantzaxaridis et al.	7,289,835	B2	10/2007	Mansfield et al.
6,939,305	B2	9/2005	Flaherty et al.	7,289,837	B2	10/2007	Mannheimer et al.
6,943,348	B1	9/2005	Coffin, IV	7,292,883	B2	11/2007	De Felice et al.
6,950,687	B2	9/2005	Al-Ali	7,295,866	B2	11/2007	Al-Ali
6,950,698	B2	9/2005	Sarkela et al.	7,313,427	B2	12/2007	Benni
6,956,650	B2	10/2005	Boas et al.	7,328,053	B1	2/2008	Diab et al.
6,958,815	B2	10/2005	Bevilacqua et al.	7,332,784	B2	2/2008	Mills et al.
6,961,598	B2	11/2005	Diab	7,333,647	B2	2/2008	Boas et al.
6,970,792	B1	11/2005	Diab	7,340,287	B2	3/2008	Mason et al.
6,975,901	B2	12/2005	Philip	7,341,559	B2	3/2008	Schulz et al.
6,979,812	B2	12/2005	Al-Ali	7,343,186	B2	3/2008	Lamego et al.
6,985,763	B2	1/2006	Boas et al.	7,343,187	B2	3/2008	Stetson
6,985,764	B2	1/2006	Mason et al.	7,349,726	B2	3/2008	Casciani et al.
6,993,371	B2	1/2006	Kiani et al.	D566,282	S	4/2008	Al-Ali et al.
6,993,380	B1	1/2006	Modarres	7,355,512	B1	4/2008	Al-Ali
6,996,427	B2	2/2006	Ali et al.	7,355,688	B2	4/2008	Lash et al.
6,999,904	B2	2/2006	Weber et al.	7,356,365	B2	4/2008	Schurman
7,003,338	B2	2/2006	Weber et al.	D568,479	S	5/2008	Mao et al.
7,003,339	B2	2/2006	Diab et al.	7,371,981	B2	5/2008	Abdul-Hafiz
7,010,341	B2	3/2006	Chance	7,373,193	B2	5/2008	Al-Ali et al.
				7,373,194	B2	5/2008	Weber et al.
				7,373,198	B2	5/2008	Bibian et al.
				7,376,453	B1	5/2008	Diab et al.
				7,376,454	B2	5/2008	Casciani et al.

(56)

References Cited

U.S. PATENT DOCUMENTS

7,377,794 B2	5/2008	Al-Ali et al.	7,910,875 B2	3/2011	Al-Ali
7,377,899 B2	5/2008	Weber et al.	7,919,713 B2	4/2011	Al-Ali et al.
7,383,070 B2	6/2008	Diab et al.	7,937,128 B2	5/2011	Al-Ali
7,392,074 B2	6/2008	Isaacson et al.	7,937,129 B2	5/2011	Mason et al.
7,415,297 B2	8/2008	Al-Ali et al.	7,937,130 B2	5/2011	Diab et al.
7,415,298 B2	8/2008	Casciani et al.	7,941,199 B2	5/2011	Kiani
7,427,165 B2	9/2008	Benaron et al.	7,951,086 B2	5/2011	Flaherty et al.
7,428,432 B2	9/2008	Ali et al.	7,957,780 B2	6/2011	Lamego et al.
7,428,434 B2	9/2008	Tromberg et al.	7,962,188 B2	6/2011	Kiani et al.
7,438,683 B2	10/2008	Al-Ali et al.	7,962,190 B1	6/2011	Diab et al.
7,440,787 B2	10/2008	Diab	7,976,472 B2	7/2011	Kiani
7,454,240 B2	11/2008	Diab et al.	7,988,637 B2	8/2011	Diab
7,457,652 B2	11/2008	Porges et al.	7,990,382 B2	8/2011	Kiani
7,467,002 B2	12/2008	Weber et al.	7,991,446 B2	8/2011	Ali et al.
7,469,157 B2	12/2008	Diab et al.	8,000,761 B2	8/2011	Al-Ali
7,471,969 B2	12/2008	Diab et al.	8,008,088 B2	8/2011	Bellott et al.
7,471,971 B2	12/2008	Diab et al.	RE42,753 E	9/2011	Kiani-Azarbayjany et al.
7,471,978 B2*	12/2008	John et al. 600/544	8,019,400 B2	9/2011	Diab et al.
7,474,245 B1	1/2009	Wang et al.	8,028,701 B2	10/2011	Al-Ali et al.
7,478,108 B2	1/2009	Townsend et al.	8,029,765 B2	10/2011	Bellott et al.
7,483,729 B2	1/2009	Al-Ali et al.	8,036,728 B2	10/2011	Diab et al.
7,483,730 B2	1/2009	Diab et al.	8,046,040 B2	10/2011	Ali et al.
7,483,731 B2	1/2009	Hoarau et al.	8,046,041 B2	10/2011	Diab et al.
7,489,958 B2	2/2009	Diab et al.	8,046,042 B2	10/2011	Diab et al.
7,496,391 B2	2/2009	Diab et al.	8,048,040 B2	11/2011	Kiani
7,496,393 B2	2/2009	Diab et al.	8,050,728 B2	11/2011	Al-Ali et al.
7,496,400 B2	2/2009	Hoskonen et al.	8,108,039 B2*	1/2012	Saliga et al. 600/544
D587,657 S	3/2009	Al-Ali et al.	RE43,169 E	2/2012	Parker
7,499,740 B2	3/2009	Nordstrom et al.	8,118,620 B2	2/2012	Al-Ali et al.
7,499,741 B2	3/2009	Diab et al.	8,126,528 B2	2/2012	Diab et al.
7,499,835 B2	3/2009	Weber et al.	8,128,572 B2	3/2012	Diab et al.
7,500,950 B2	3/2009	Al-Ali et al.	8,130,105 B2	3/2012	Al-Ali et al.
7,509,154 B2	3/2009	Diab et al.	8,145,287 B2	3/2012	Diab et al.
7,509,494 B2	3/2009	Al-Ali	8,150,487 B2	4/2012	Diab et al.
7,510,849 B2	3/2009	Schurman et al.	8,175,672 B2	5/2012	Parker
7,515,948 B1	4/2009	Balberg et al.	8,180,420 B2	5/2012	Diab et al.
7,522,949 B2	4/2009	Berson et al.	8,182,443 B1	5/2012	Kiani
7,526,328 B2	4/2009	Diab et al.	8,185,180 B2	5/2012	Diab et al.
7,530,942 B1	5/2009	Diab	8,190,223 B2	5/2012	Al-Ali et al.
7,530,949 B2	5/2009	Al Ali et al.	8,190,227 B2	5/2012	Diab et al.
7,530,955 B2	5/2009	Diab et al.	8,203,438 B2	6/2012	Kiani et al.
7,563,110 B2	7/2009	Al-Ali et al.	8,203,704 B2	6/2012	Merritt et al.
7,596,398 B2	9/2009	Al-Ali et al.	8,224,411 B2	7/2012	Al-Ali et al.
7,610,082 B2	10/2009	Chance	8,228,181 B2	7/2012	Al-Ali
7,618,375 B2	11/2009	Flaherty	8,229,533 B2	7/2012	Diab et al.
D606,659 S	12/2009	Kiani et al.	8,233,955 B2	7/2012	Al-Ali et al.
7,632,148 B1*	12/2009	Kawamura H01R 13/5221 439/607.41	8,244,325 B2	8/2012	Al-Ali et al.
7,647,083 B2	1/2010	Al-Ali et al.	8,255,026 B1	8/2012	Al-Ali
D609,193 S	2/2010	Al-Ali et al.	8,255,027 B2	8/2012	Al-Ali et al.
D614,305 S	4/2010	Al-Ali et al.	8,255,028 B2	8/2012	Al-Ali et al.
RE41,317 E	5/2010	Parker	8,260,577 B2	9/2012	Weber et al.
7,729,733 B2	6/2010	Al-Ali et al.	8,265,723 B1	9/2012	McHale et al.
7,734,320 B2	6/2010	Al-Ali	8,274,360 B2	9/2012	Sampath et al.
7,761,127 B2	7/2010	Al-Ali et al.	8,301,217 B2	10/2012	Al-Ali et al.
7,761,128 B2	7/2010	Al-Ali et al.	8,310,336 B2	11/2012	Muhsin et al.
7,764,982 B2	7/2010	Dalke et al.	8,315,683 B2	11/2012	Al-Ali et al.
D621,516 S	8/2010	Kiani et al.	RE43,860 E	12/2012	Parker
7,791,155 B2	9/2010	Diab	8,337,403 B2	12/2012	Al-Ali et al.
7,801,581 B2	9/2010	Diab	8,346,330 B2	1/2013	Lamego
7,822,452 B2	10/2010	Schurman et al.	8,353,842 B2	1/2013	Al-Ali et al.
RE41,912 E	11/2010	Parker	8,355,766 B2	1/2013	MacNeish, III et al.
7,844,313 B2	11/2010	Kiani et al.	8,359,080 B2	1/2013	Diab et al.
7,844,314 B2	11/2010	Al-Ali	8,364,223 B2	1/2013	Al-Ali et al.
7,844,315 B2	11/2010	Al-Ali	8,364,226 B2	1/2013	Diab et al.
7,865,222 B2	1/2011	Weber et al.	8,374,665 B2	2/2013	Lamego
7,873,497 B2	1/2011	Weber et al.	8,385,995 B2	2/2013	Al-Ali et al.
7,880,606 B2	2/2011	Al-Ali	8,385,996 B2	2/2013	Smith et al.
7,880,626 B2	2/2011	Al-Ali et al.	8,388,353 B2	3/2013	Kiani et al.
7,891,355 B2	2/2011	Al-Ali et al.	8,399,822 B2	3/2013	Al-Ali
7,894,868 B2	2/2011	Al-Ali et al.	8,401,602 B2	3/2013	Kiani
7,899,507 B2	3/2011	Al-Ali et al.	8,405,608 B2	3/2013	Al-Ali et al.
7,899,518 B2	3/2011	Trepagnier et al.	8,414,499 B2	4/2013	Al-Ali et al.
7,904,132 B2	3/2011	Weber et al.	8,418,524 B2	4/2013	Al-Ali
7,909,772 B2	3/2011	Popov et al.	8,423,106 B2	4/2013	Lamego et al.
			8,428,967 B2	4/2013	Olsen et al.
			8,430,817 B1	4/2013	Al-Ali et al.
			8,437,825 B2	5/2013	Dalvi et al.
			8,455,290 B2	6/2013	Siskavich
			8,457,703 B2	6/2013	Al-Ali

(56)

References Cited

U.S. PATENT DOCUMENTS

8,457,707 B2	6/2013	Kiani	8,790,268 B2	7/2014	Al-Ali
8,463,349 B2	6/2013	Diab et al.	8,801,613 B2	8/2014	Al-Ali et al.
8,466,286 B2	6/2013	Bellott et al.	8,821,397 B2	9/2014	Al-Ali et al.
8,467,880 B2*	6/2013	Glukhovskiy et al. 607/48	8,821,415 B2	9/2014	Al-Ali et al.
8,471,713 B2	6/2013	Poeze et al.	8,830,449 B1	9/2014	Lamego et al.
8,473,020 B2	6/2013	Kiani et al.	8,831,700 B2	9/2014	Schurman et al.
8,483,787 B2	7/2013	Al-Ali et al.	8,840,549 B2	9/2014	Al-Ali et al.
8,489,364 B2	7/2013	Weber et al.	8,847,740 B2	9/2014	Kiani et al.
8,498,684 B2	7/2013	Weber et al.	8,849,365 B2	9/2014	Smith et al.
8,509,867 B2	8/2013	Workman et al.	8,852,094 B2	10/2014	Al-Ali et al.
8,515,509 B2	8/2013	Bruinsma et al.	8,852,994 B2	10/2014	Wojtczuk et al.
8,523,781 B2	9/2013	Al-Ali	8,868,147 B2	10/2014	Stippick et al.
8,529,301 B2	9/2013	Al-Ali et al.	8,868,150 B2	10/2014	Al-Ali et al.
8,532,727 B2	9/2013	Ali et al.	8,870,792 B2	10/2014	Al-Ali et al.
8,532,728 B2	9/2013	Diab et al.	8,886,271 B2	11/2014	Kiani et al.
D692,145 S	10/2013	Al-Ali et al.	8,888,539 B2	11/2014	Al-Ali et al.
8,547,209 B2	10/2013	Kiani et al.	8,888,708 B2	11/2014	Diab et al.
8,548,548 B2	10/2013	Al-Ali	8,892,180 B2	11/2014	Weber et al.
8,548,550 B2	10/2013	Al-Ali et al.	8,897,847 B2	11/2014	Al-Ali
8,560,032 B2	10/2013	Al-Ali et al.	8,909,310 B2	12/2014	Lamego et al.
8,560,034 B1	10/2013	Diab et al.	8,911,377 B2	12/2014	Al-Ali
8,570,167 B2	10/2013	Al-Ali	8,912,909 B2	12/2014	Al-Ali et al.
8,570,503 B2	10/2013	Vo et al.	8,920,317 B2	12/2014	Al-Ali et al.
8,571,617 B2	10/2013	Reichgott et al.	8,921,699 B2	12/2014	Al-Ali et al.
8,571,618 B1	10/2013	Lamego et al.	8,922,382 B2	12/2014	Al-Ali et al.
8,571,619 B2	10/2013	Al-Ali et al.	8,929,964 B2	1/2015	Al-Ali et al.
8,577,431 B2	11/2013	Lamego et al.	8,942,777 B2	1/2015	Diab et al.
8,581,732 B2	11/2013	Al-Ali et al.	8,948,834 B2	2/2015	Diab et al.
8,584,345 B2	11/2013	Al-Ali et al.	8,948,835 B2	2/2015	Diab
8,588,880 B2	11/2013	Abdul-Hafiz et al.	8,965,471 B2	2/2015	Lamego
8,600,467 B2	12/2013	Al-Ali et al.	8,983,564 B2	3/2015	Al-Ali
8,606,342 B2	12/2013	Diab	8,989,831 B2	3/2015	Al-Ali et al.
8,626,255 B2	1/2014	Al-Ali et al.	8,996,085 B2	3/2015	Kiani et al.
8,630,691 B2	1/2014	Lamego et al.	8,998,809 B2	4/2015	Kiani
8,634,889 B2	1/2014	Al-Ali et al.	9,028,429 B2	5/2015	Telfort et al.
8,641,631 B2	2/2014	Sierra et al.	9,037,207 B2	5/2015	Al-Ali et al.
8,652,060 B2	2/2014	Al-Ali	9,066,666 B2	6/2015	Kiani
8,660,489 B2*	2/2014	Barrenscheen H04B 5/0031 375/258	9,066,680 B1	6/2015	Al-Ali et al.
8,663,107 B2	3/2014	Kiani	9,072,474 B2	7/2015	Al-Ali et al.
8,666,468 B1	3/2014	Al-Ali	9,084,569 B2	7/2015	Weber et al.
8,667,967 B2	3/2014	Al-Ali et al.	9,095,316 B2	8/2015	Welch et al.
8,670,811 B2	3/2014	O'Reilly	9,106,038 B2	8/2015	Telfort et al.
8,670,814 B2	3/2014	Diab et al.	9,107,625 B2	8/2015	Telfort et al.
8,676,286 B2	3/2014	Weber et al.	9,107,626 B2	8/2015	Al-Ali et al.
8,682,407 B2	3/2014	Al-Ali	9,113,831 B2	8/2015	Al-Ali
RE44,823 E	4/2014	Parker	9,113,832 B2	8/2015	Al-Ali
RE44,875 E	4/2014	Kiani et al.	9,119,595 B2	9/2015	Lamego
8,690,799 B2	4/2014	Telfort et al.	9,131,881 B2	9/2015	Diab et al.
8,700,112 B2	4/2014	Kiani	9,131,882 B2	9/2015	Al-Ali et al.
8,702,627 B2	4/2014	Telfort et al.	9,131,883 B2	9/2015	Al-Ali
8,706,179 B2	4/2014	Parker	9,131,917 B2	9/2015	Telfort et al.
8,712,494 B1	4/2014	MacNeish, III et al.	9,138,180 B1	9/2015	Coverston et al.
8,715,206 B2	5/2014	Telfort et al.	9,138,182 B2	9/2015	Al-Ali et al.
8,718,735 B2	5/2014	Lamego et al.	9,138,192 B2	9/2015	Weber et al.
8,718,737 B2	5/2014	Diab et al.	9,142,117 B2	9/2015	Muhsin et al.
8,718,738 B2	5/2014	Blank et al.	9,153,112 B1	10/2015	Kiani et al.
8,720,249 B2	5/2014	Al-Ali	9,153,121 B2	10/2015	Kiani et al.
8,721,541 B2	5/2014	Al-Ali et al.	9,161,696 B2	10/2015	Al-Ali et al.
8,721,542 B2	5/2014	Al-Ali et al.	9,161,713 B2	10/2015	Al-Ali et al.
8,723,677 B1	5/2014	Kiani	9,167,995 B2	10/2015	Lamego et al.
8,740,792 B1	6/2014	Kiani et al.	9,176,141 B2	11/2015	Al-Ali et al.
8,754,776 B2	6/2014	Poeze et al.	9,186,102 B2	11/2015	Bruinsma et al.
8,755,535 B2	6/2014	Telfort et al.	9,192,312 B2	11/2015	Al-Ali
8,755,856 B2	6/2014	Diab et al.	9,192,329 B2	11/2015	Al-Ali
8,755,872 B1	6/2014	Marinow	9,192,351 B1	11/2015	Telfort et al.
8,761,850 B2	6/2014	Lamego	9,195,385 B2	11/2015	Al-Ali et al.
8,764,671 B2	7/2014	Kiani	9,211,072 B2	12/2015	Kiani
8,768,423 B2	7/2014	Shakespeare et al.	9,211,095 B1	12/2015	Al-Ali
8,771,204 B2	7/2014	Telfort et al.	9,218,454 B2	12/2015	Kiani et al.
8,777,634 B2	7/2014	Kiani et al.	9,226,696 B2	1/2016	Kiani
8,781,543 B2	7/2014	Diab et al.	9,241,662 B2	1/2016	Al-Ali et al.
8,781,544 B2	7/2014	Al-Ali et al.	9,245,668 B1	1/2016	Vo et al.
8,781,549 B2	7/2014	Al-Ali et al.	9,259,185 B2	2/2016	Abdul-Hafiz et al.
8,788,003 B2	7/2014	Schurman et al.	9,267,572 B2	2/2016	Barker et al.
			9,277,880 B2	3/2016	Poeze et al.
			9,289,167 B2	3/2016	Diab et al.
			9,295,421 B2	3/2016	Kiani et al.
			9,307,928 B1	4/2016	Al-Ali et al.
			9,323,894 B2	4/2016	Kiani

(56)		References Cited			
		U.S. PATENT DOCUMENTS			
D755,392	S	5/2016	Hwang et al.	2007/0208269	A1* 9/2007 Mumford et al. 600/546
9,326,712	B1	5/2016	Kiani	2007/0244721	A1 10/2007 Sackner-Bernstein et al.
9,333,316	B2	5/2016	Kiani	2007/0249952	A1 10/2007 Rubin et al.
9,339,220	B2	5/2016	Lamego et al.	2008/0017800	A1 1/2008 Benni
9,341,565	B2	5/2016	Lamego et al.	2008/0234597	A1 9/2008 Becker et al.
9,351,673	B2	5/2016	Diab et al.	2008/0255469	A1 10/2008 Shieh et al.
9,351,675	B2	5/2016	Al-Ali et al.	2008/0285029	A1 11/2008 Benni et al.
9,364,181	B2	6/2016	Kiani et al.	2008/0294063	A1 11/2008 Bibian et al.
9,368,671	B2	6/2016	Wojtczuk et al.	2008/0300469	A1 12/2008 Kuo et al.
9,370,325	B2	6/2016	Al-Ali et al.	2008/0300473	A1 12/2008 Benni
9,370,326	B2	6/2016	McHale et al.	2008/0300474	A1 12/2008 Benni et al.
9,370,335	B2	6/2016	Al-ali et al.	2008/0312523	A1* 12/2008 Dunseath 600/383
9,375,185	B2	6/2016	Ali et al.	2009/0018427	A1 1/2009 Causevic et al.
9,386,953	B2	7/2016	Al-Ali	2009/0018429	A1 1/2009 Saliga et al.
9,386,961	B2	7/2016	Al-Ali et al.	2009/0036799	A1 2/2009 Sandhu et al.
9,392,945	B2	7/2016	Al-Ali et al.	2009/0108205	A1 4/2009 Duffy et al.
9,397,448	B2	7/2016	Al-Ali et al.	2009/0182209	A1 7/2009 Benni
9,408,542	B1	8/2016	Kinast et al.	2009/0247984	A1 10/2009 Lamego et al.
9,436,645	B2	9/2016	Al-Ali et al.	2009/0275844	A1 11/2009 Al-Ali
9,445,759	B1	9/2016	Lamego et al.	2009/0281403	A1 11/2009 Benni
9,466,919	B2	10/2016	Kiani et al.	2009/0299157	A1 12/2009 Telfort et al.
9,474,474	B2	10/2016	Lamego et al.	2010/0004518	A1 1/2010 Vo et al.
9,480,422	B2	11/2016	Al-Ali	2010/0030040	A1 2/2010 Poeze et al.
9,480,435	B2	11/2016	Olsen	2010/0049018	A1 2/2010 Duffy et al.
9,492,110	B2	11/2016	Al-Ali et al.	2010/0144164	A1* 6/2010 Wang H01R 13/6205 439/39
9,510,779	B2	12/2016	Poeze et al.	2010/0261979	A1 10/2010 Kiani
9,517,024	B2	12/2016	Kiani et al.	2011/0001605	A1 1/2011 Kiani et al.
9,532,722	B2	1/2017	Lamego et al.	2011/0082711	A1 4/2011 Poeze et al.
9,538,949	B2	1/2017	Al-Ali et al.	2011/0105854	A1 5/2011 Kiani et al.
9,538,980	B2	1/2017	Telfort et al.	2011/0189952	A1* 8/2011 Barrenscheen H04B 5/0031 455/41.1
9,549,696	B2	1/2017	Lamego et al.	2011/0208015	A1 8/2011 Welch et al.
9,554,737	B2	1/2017	Schurman et al.	2011/0209915	A1 9/2011 Telfort et al.
2002/0019588	A1	2/2002	Marro et al.	2011/0213212	A1 9/2011 Al-Ali
2002/0029005	A1	3/2002	Levendowski et al.	2011/0230733	A1 9/2011 Al-Ali
2002/0082513	A1	6/2002	Ennen et al.	2011/0237911	A1 9/2011 Lamego et al.
2002/0085174	A1	7/2002	Bolger et al.	2012/0059267	A1 3/2012 Lamego et al.
2002/0123693	A1	9/2002	Lange et al.	2012/0116175	A1 5/2012 Al-Ali et al.
2002/0183634	A1	12/2002	Rantala et al.	2012/0179006	A1 7/2012 Jansen et al.
2002/0188216	A1	12/2002	Kayyali et al.	2012/0209082	A1 8/2012 Al-Ali
2002/0193844	A1*	12/2002	Michelson et al. 607/48	2012/0209084	A1 8/2012 Olsen et al.
2003/0069516	A1	4/2003	Becker et al.	2012/0227739	A1 9/2012 Kiani
2003/0145854	A1	8/2003	Hickle	2012/0283524	A1 11/2012 Kiani et al.
2003/0158587	A1	8/2003	Esteller et al.	2012/0286955	A1 11/2012 Welch et al.
2003/0204148	A1	10/2003	Lange et al.	2012/0296178	A1 11/2012 Lamego et al.
2003/0225323	A1*	12/2003	Kiani et al. 600/323	2012/0319816	A1 12/2012 Al-Ali
2004/0056103	A1*	3/2004	Sepponen 235/487	2012/0330112	A1 12/2012 Lamego et al.
2004/0073098	A1	4/2004	Geva et al.	2013/0023775	A1 1/2013 Lamego et al.
2004/0073129	A1	4/2004	Caldwell et al.	2013/0041591	A1 2/2013 Lamego
2004/0082876	A1	4/2004	Viertio-Oja et al.	2013/0045685	A1 2/2013 Kiani
2004/0167418	A1	8/2004	Nguyen et al.	2013/0046204	A1 2/2013 Lamego et al.
2004/0193068	A1	9/2004	Burton et al.	2013/0060108	A1 3/2013 Schurman et al.
2004/0243017	A1	12/2004	Causevic	2013/0060147	A1 3/2013 Welch et al.
2004/0267153	A1	12/2004	Bergethon	2013/0096405	A1 4/2013 Garfio
2005/0010116	A1	1/2005	Korhonen et al.	2013/0096936	A1 4/2013 Sampath et al.
2005/0059899	A1	3/2005	Merilainen et al.	2013/0109935	A1 5/2013 Al-Ali et al.
2005/0081847	A1	4/2005	Lee et al.	2013/0162433	A1 6/2013 Muhsin et al.
2005/0090754	A1	4/2005	Wolff et al.	2013/0190581	A1 7/2013 Al-Ali et al.
2005/0113704	A1	5/2005	Lawson et al.	2013/0197328	A1 8/2013 Diab et al.
2005/0119547	A1	6/2005	Shastri et al.	2013/0211214	A1 8/2013 Olsen
2005/0217674	A1	10/2005	Burton et al.	2013/0243021	A1 9/2013 Siskavich
2005/0277826	A1*	12/2005	Dunseath, Jr. 600/410	2013/0253334	A1 9/2013 Al-Ali et al.
2006/0100538	A1	5/2006	Genger et al.	2013/0274571	A1 10/2013 Diab et al.
2006/0116556	A1	6/2006	Duhamel	2013/0296672	A1 11/2013 O'Neil et al.
2006/0167368	A1	7/2006	Sarkela	2013/0317370	A1 11/2013 Dalvi et al.
2006/0189861	A1	8/2006	Chen et al.	2013/0324808	A1 12/2013 Al-Ali et al.
2006/0217628	A1	9/2006	Huiku	2013/0331670	A1 12/2013 Kiani
2006/0235315	A1	10/2006	Akselrod	2013/0338461	A1 12/2013 Lamego et al.
2006/0241356	A1	10/2006	Flaherty	2014/0012100	A1 1/2014 Al-Ali et al.
2006/0241562	A1	10/2006	John et al.	2014/0025306	A1 1/2014 Weber et al.
2006/0293608	A1	12/2006	Rothman et al.	2014/0034353	A1 2/2014 Al-Ali et al.
2007/0010755	A1	1/2007	Sarkela et al.	2014/0051952	A1 2/2014 Reichgott et al.
2007/0010756	A1	1/2007	Viertio-Oja	2014/0051953	A1 2/2014 Lamego et al.
2007/0010795	A1	1/2007	Sarkela et al.	2014/0058230	A1 2/2014 Abdul-Hafiz et al.
2007/0173802	A1*	7/2007	Keppel 606/34	2014/0066783	A1 3/2014 Kiani et al.
2007/0185407	A1	8/2007	Xu et al.	2014/0077956	A1 3/2014 Sampath et al.
				2014/0081100	A1 3/2014 Muhsin et al.
				2014/0081175	A1 3/2014 Telfort

(56)

References Cited

U.S. PATENT DOCUMENTS

2014/0094667 A1 4/2014 Schurman et al.
 2014/0100434 A1 4/2014 Diab et al.
 2014/0114199 A1 4/2014 Lamego et al.
 2014/0120564 A1 5/2014 Workman et al.
 2014/0121482 A1 5/2014 Merritt et al.
 2014/0121483 A1 5/2014 Kiani
 2014/0125495 A1 5/2014 Al-Ali
 2014/0127137 A1 5/2014 Bellott et al.
 2014/0128696 A1 5/2014 Al-Ali
 2014/0128699 A1 5/2014 Al-Ali et al.
 2014/0129702 A1 5/2014 Lamego et al.
 2014/0135588 A1 5/2014 Al-Ali et al.
 2014/0142401 A1 5/2014 Al-Ali et al.
 2014/0142402 A1 5/2014 Al-Ali et al.
 2014/0163344 A1 6/2014 Al-Ali
 2014/0163402 A1 6/2014 Lamego et al.
 2014/0166076 A1 6/2014 Kiani et al.
 2014/0171763 A1 6/2014 Diab
 2014/0180038 A1 6/2014 Kiani
 2014/0180154 A1 6/2014 Sierra et al.
 2014/0194709 A1 7/2014 Al-Ali et al.
 2014/0194711 A1 7/2014 Al-Ali
 2014/0194766 A1 7/2014 Al-Ali et al.
 2014/0200420 A1 7/2014 Al-Ali
 2014/0206963 A1 7/2014 Al-Ali
 2014/0213864 A1 7/2014 Abdul-Hafiz et al.
 2014/0243627 A1 8/2014 Diab et al.
 2014/0266790 A1 9/2014 Al-Ali et al.
 2014/0275808 A1 9/2014 Poeze et al.
 2014/0275835 A1 9/2014 Lamego et al.
 2014/0275871 A1 9/2014 Lamego et al.
 2014/0275872 A1 9/2014 Merritt et al.
 2014/0275881 A1 9/2014 Lamego et al.
 2014/0288400 A1 9/2014 Diab et al.
 2014/0296664 A1 10/2014 Bruinsma et al.
 2014/0303520 A1 10/2014 Telfort et al.
 2014/0309506 A1 10/2014 Lamego et al.
 2014/0316228 A1 10/2014 Blank et al.
 2014/0323825 A1 10/2014 Al-Ali et al.
 2014/0330092 A1 11/2014 Al-Ali et al.
 2014/0330098 A1 11/2014 Merritt et al.
 2014/0330099 A1 11/2014 Al-Ali et al.
 2014/0333440 A1 11/2014 Kiani
 2014/0336481 A1 11/2014 Shakespeare et al.
 2014/0343436 A1 11/2014 Kiani
 2015/0018650 A1 1/2015 Al-Ali et al.
 2015/0201874 A1 7/2015 Diab
 2015/0208966 A1 7/2015 Al-Ali
 2015/0216459 A1 8/2015 Al-Ali et al.
 2015/0230755 A1 8/2015 Al-Ali et al.
 2015/0238722 A1 8/2015 Al-Ali
 2015/0245773 A1 9/2015 Lamego et al.
 2015/0245794 A1 9/2015 Al-Ali
 2015/0257689 A1 9/2015 Al-Ali et al.
 2015/0272514 A1 10/2015 Kiani et al.
 2015/0351697 A1 12/2015 Weber et al.
 2015/0351704 A1 12/2015 Kiani et al.
 2015/0359429 A1 12/2015 Al-Ali et al.
 2015/0366472 A1 12/2015 Kiani
 2015/0366507 A1 12/2015 Blank
 2015/0374298 A1 12/2015 Al-Ali et al.
 2015/0380875 A1 12/2015 Coverston et al.
 2016/0000362 A1 1/2016 Diab et al.
 2016/0007930 A1 1/2016 Weber et al.
 2016/0029932 A1 2/2016 Al-Ali
 2016/0029933 A1 2/2016 Al-Ali et al.
 2016/0045118 A1 2/2016 Kiani
 2016/0051205 A1 2/2016 Al-Ali et al.
 2016/0058338 A1 3/2016 Schurman et al.
 2016/0058347 A1 3/2016 Reichgott et al.
 2016/0066823 A1 3/2016 Al-Ali et al.
 2016/0066824 A1 3/2016 Al-Ali et al.
 2016/0066879 A1 3/2016 Telfort et al.
 2016/0072429 A1 3/2016 Kiani et al.
 2016/0073967 A1 3/2016 Lamego et al.

2016/0081552 A1 3/2016 Wojtczuk et al.
 2016/0095543 A1 4/2016 Telfort et al.
 2016/0095548 A1 4/2016 Al-Ali et al.
 2016/0103598 A1 4/2016 Al-Ali et al.
 2016/0113527 A1 4/2016 Al-Ali
 2016/0143548 A1 5/2016 Al-Ali
 2016/0166183 A1 6/2016 Poeze et al.
 2016/0166188 A1 6/2016 Bruinsma et al.
 2016/0166210 A1 6/2016 Al-Ali
 2016/0192869 A1 7/2016 Kiani et al.
 2016/0196388 A1 7/2016 Lamego
 2016/0197436 A1 7/2016 Barker et al.
 2016/0213281 A1 7/2016 Eckerbom et al.
 2016/0228043 A1 8/2016 O'Neil et al.
 2016/0233632 A1 8/2016 Scruggs et al.
 2016/0234944 A1 8/2016 Schmidt et al.
 2016/0270735 A1 9/2016 Diab et al.
 2016/0283665 A1 9/2016 Sampath et al.
 2016/0287090 A1 10/2016 Al-Ali et al.
 2016/0287786 A1 10/2016 Kiani
 2016/0296169 A1 10/2016 McHale et al.
 2016/0310052 A1 10/2016 Al-Ali et al.
 2016/0314260 A1 10/2016 Kiani
 2016/0324486 A1 11/2016 Al-Ali et al.
 2016/0324488 A1 11/2016 Olsen
 2016/0327984 A1 11/2016 Al-Ali et al.
 2016/0328528 A1 11/2016 Al-Ali et al.
 2016/0331332 A1 11/2016 Al-Ali
 2016/0367173 A1 12/2016 Dalvi et al.
 2017/0007134 A1 1/2017 Al-Ali et al.
 2017/0007190 A1 1/2017 Al-Ali et al.
 2017/0007198 A1 1/2017 Al-Ali et al.
 2017/0014084 A1 1/2017 Al-Ali et al.
 2017/0021099 A1 1/2017 Al-Ali et al.
 2017/0027456 A1 2/2017 Kinast et al.

FOREIGN PATENT DOCUMENTS

EP 638193 2/1995
 EP 1250886 10/2002
 EP 1624798 11/2004
 EP 1779257 5/2007
 WO WO 91/09372 6/1991
 WO WO 91/19453 12/1991
 WO WO 92/02176 2/1992
 WO WO 93/21615 10/1993
 WO WO 99/08589 2/1999
 WO WO 00/21435 4/2000
 WO WO 00/56211 9/2000
 WO WO 00/56212 9/2000
 WO WO 01/30414 5/2001
 WO WO 00/21432 4/2002
 WO WO 2004/028362 4/2004
 WO WO 2004/038890 A1 * 5/2004 H02J 7/02
 WO WO 2004/054441 7/2004
 WO WO 2007/059248 5/2007
 WO WO 2007/140535 12/2007
 WO WO 2007/140536 12/2007
 WO WO 2007/149553 12/2007
 WO WO 2008/015449 2/2008
 WO WO 2008/040846 4/2008
 WO WO 2008/043365 4/2008
 WO WO 2008/109694 9/2008
 WO WO 2008/109699 9/2008
 WO WO 2008/119029 10/2008
 WO WO 2008/119031 10/2008
 WO WO 2008/122082 10/2008
 WO WO 2008/138340 11/2008

OTHER PUBLICATIONS

Partial International Search Report for International Application No. PCT/US2011/053540, date of mailing: Jan. 30, 2012, in 4 pages.
 International Search Report for International Application No. PCT/US2011/053540, date of mailing: May 3, 2012, in 14 pages.

* cited by examiner

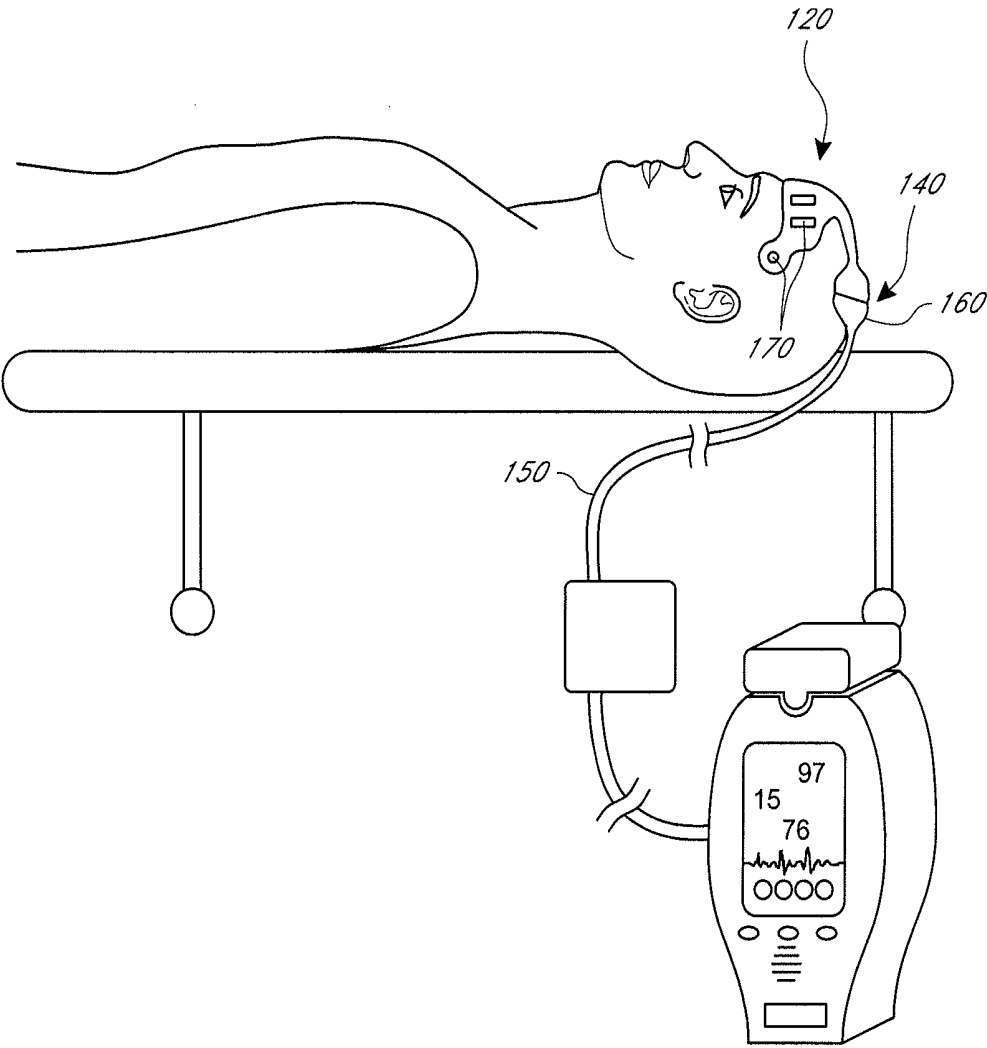

FIG. 1A

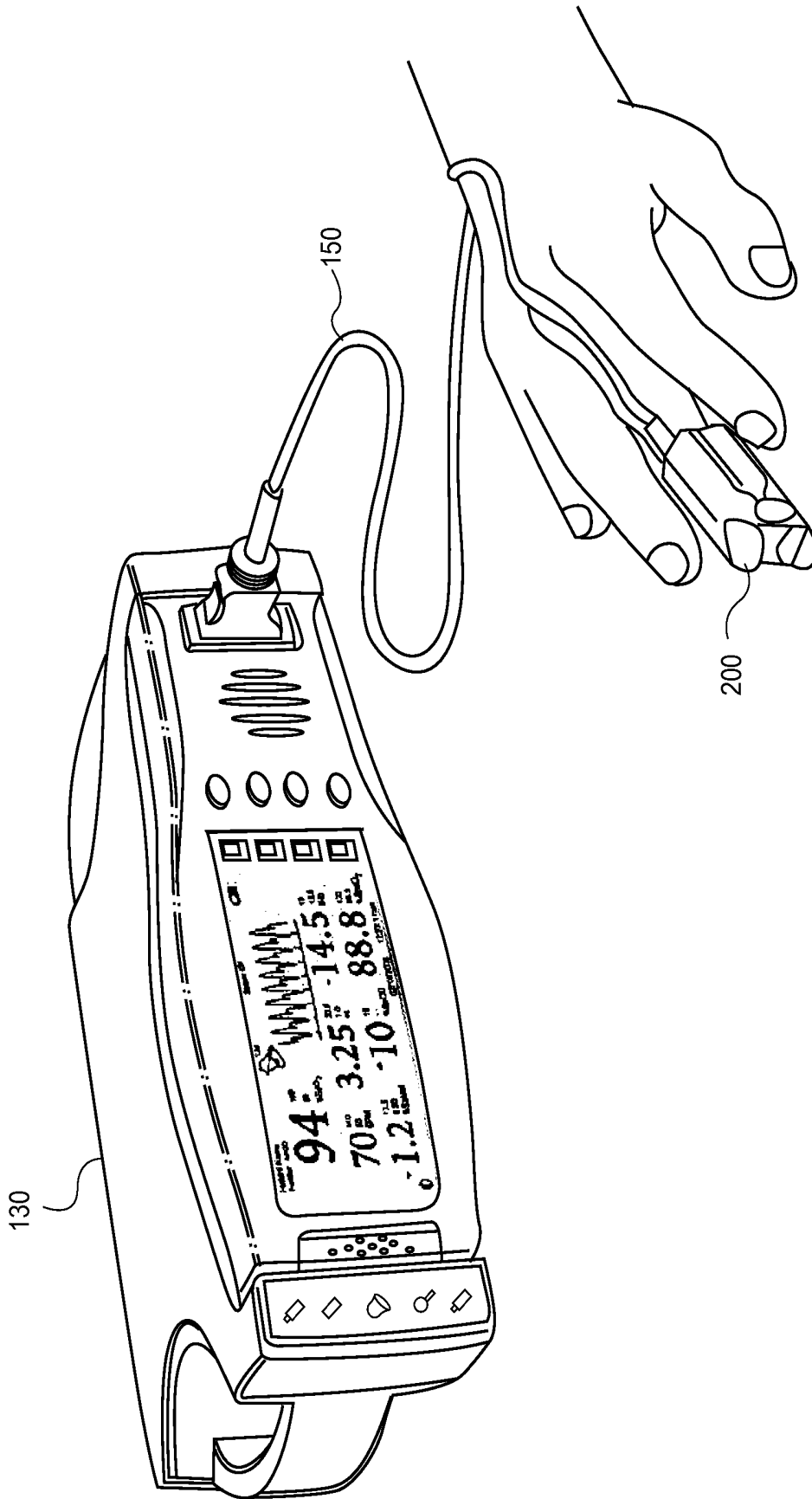
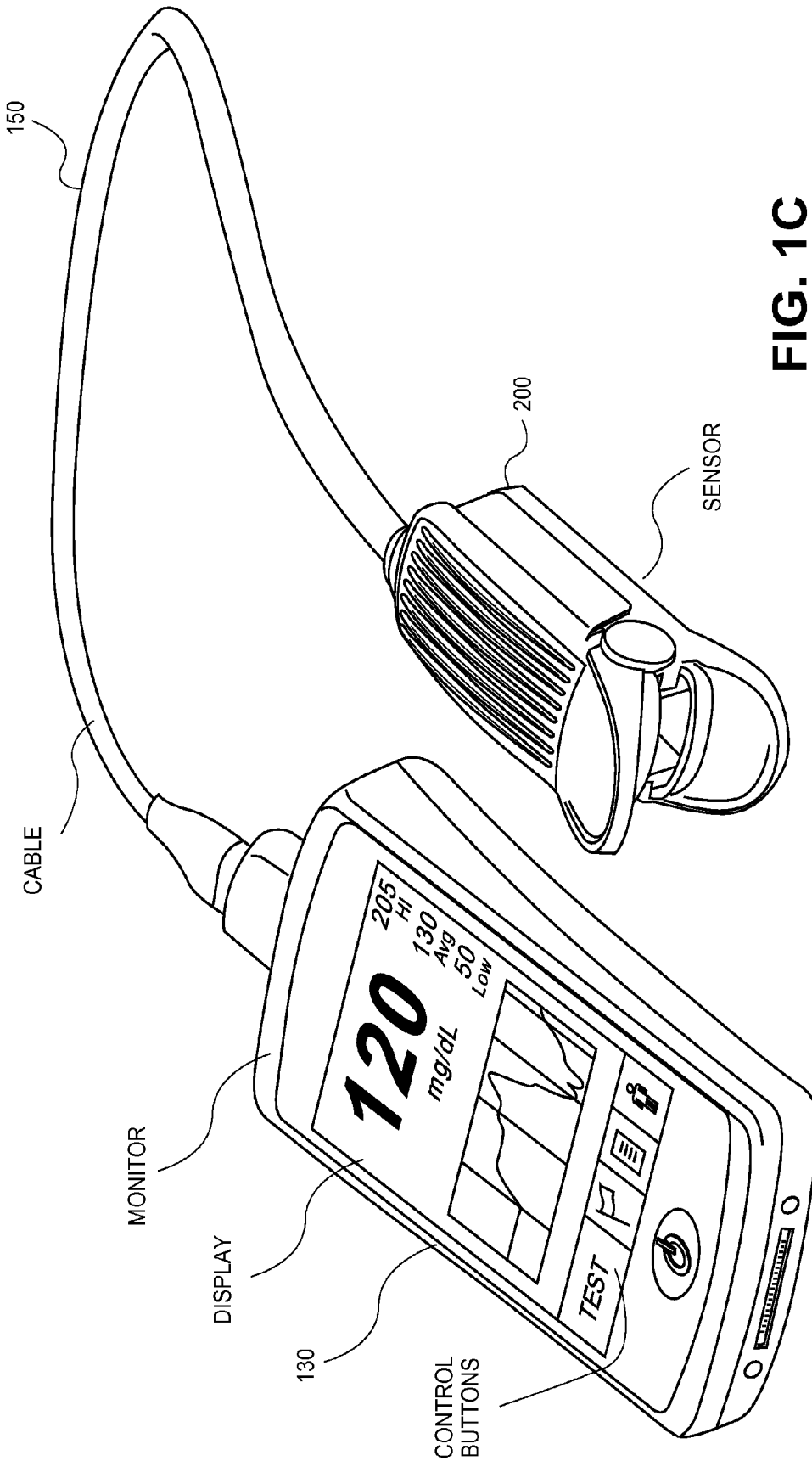

FIG. 1B



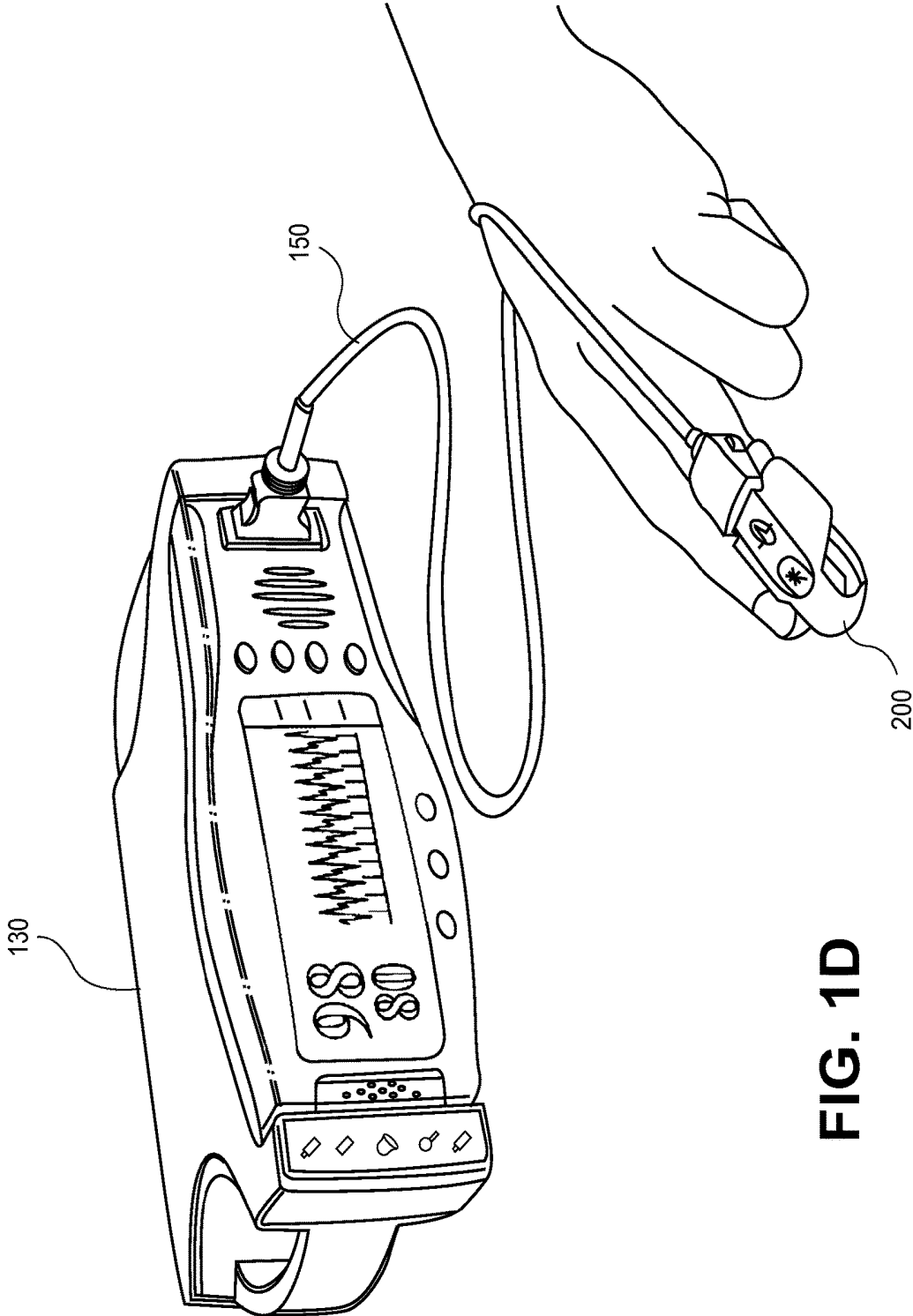

FIG. 1D

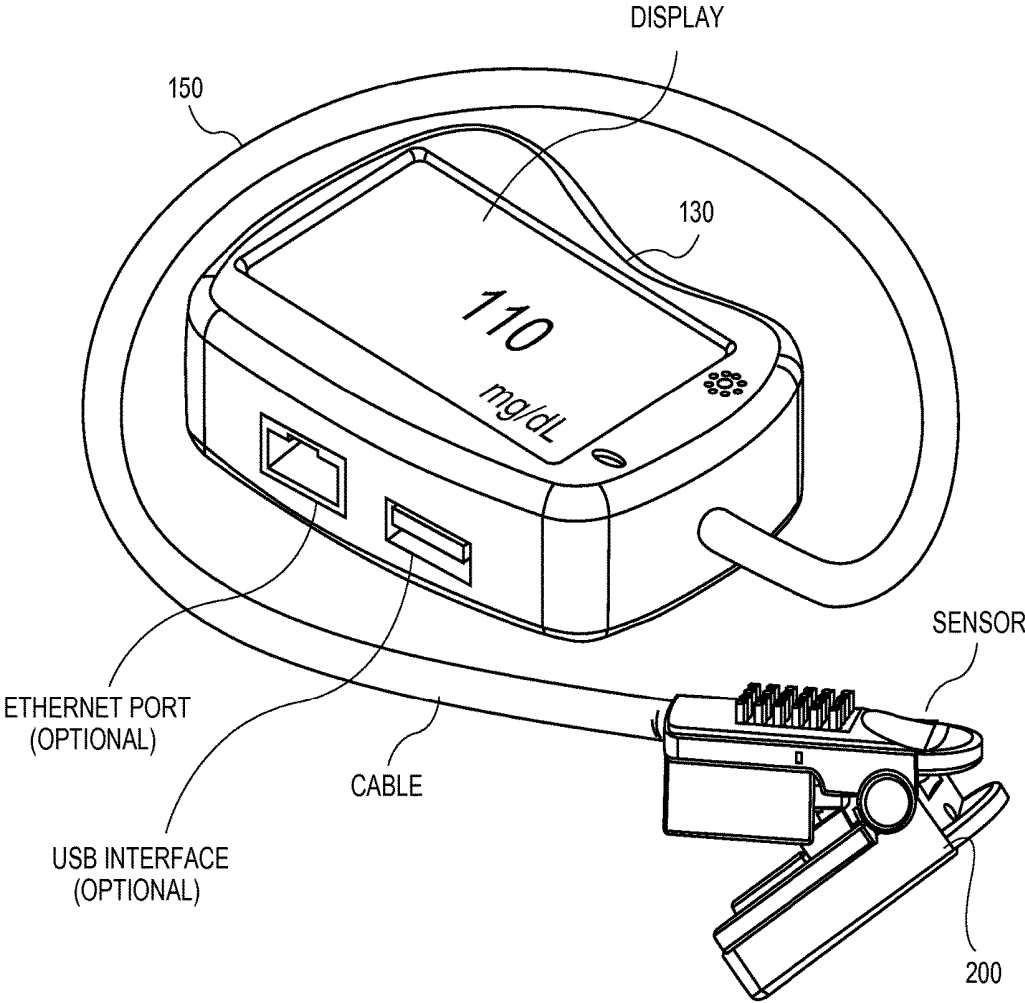
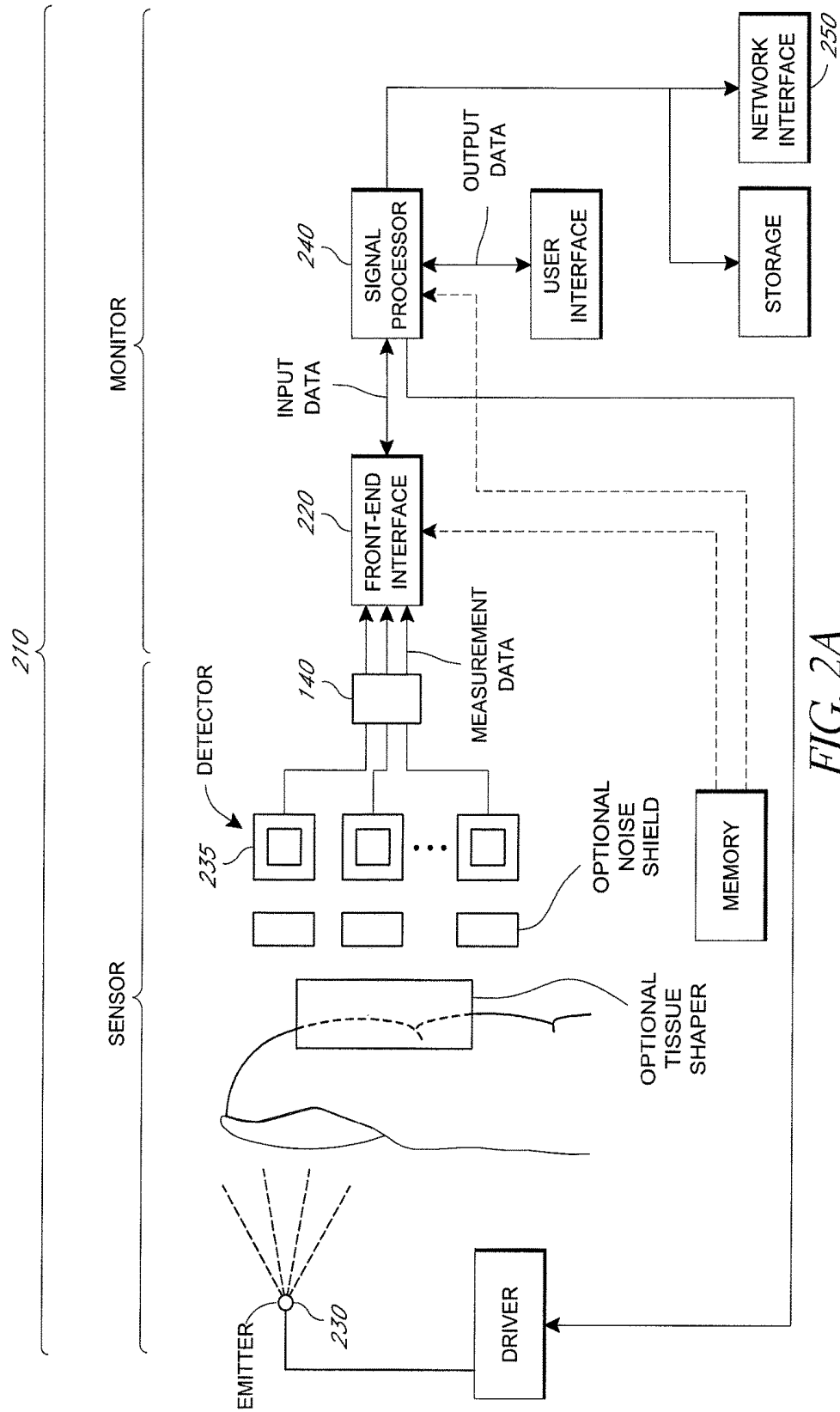

FIG. 1E



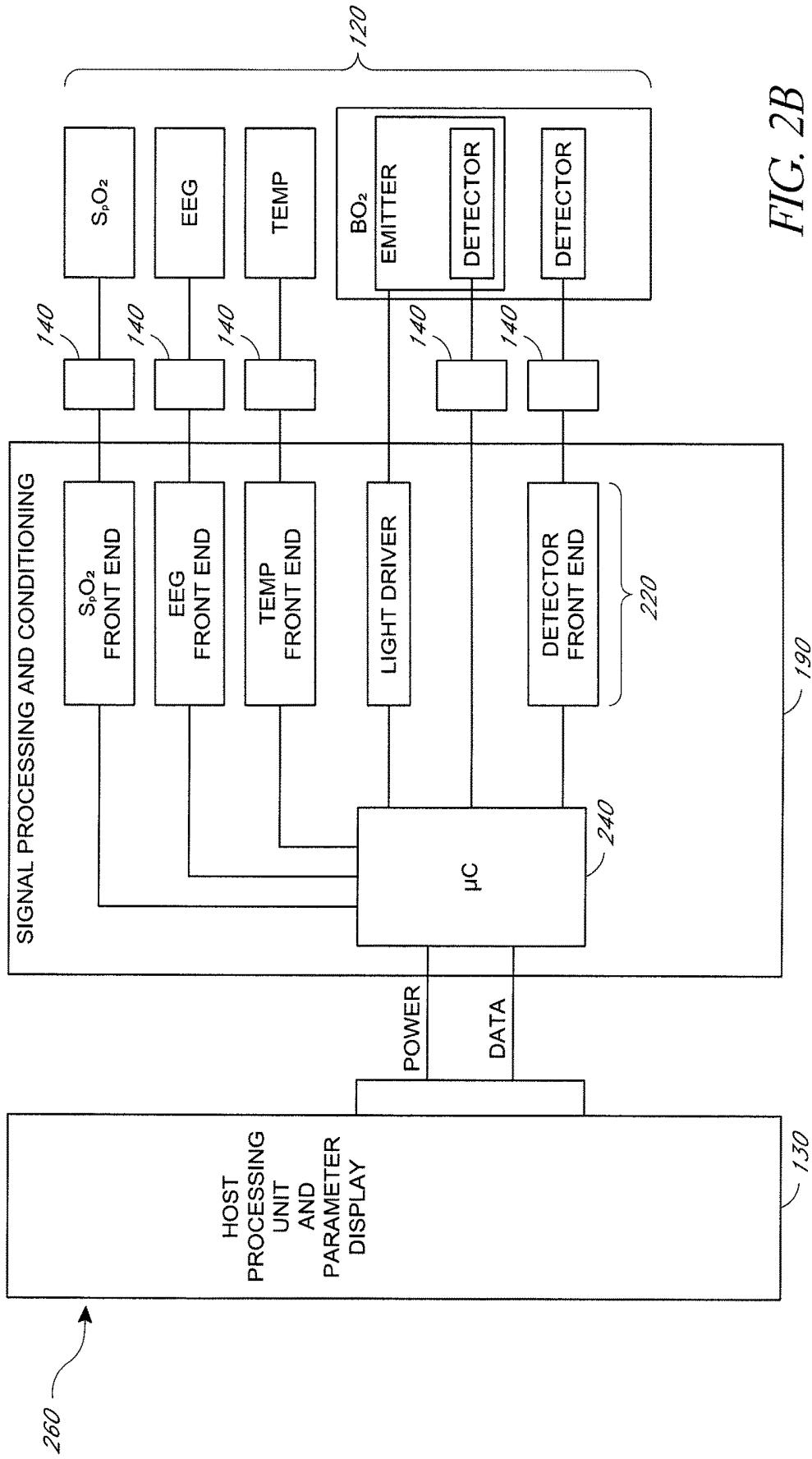

FIG. 2B

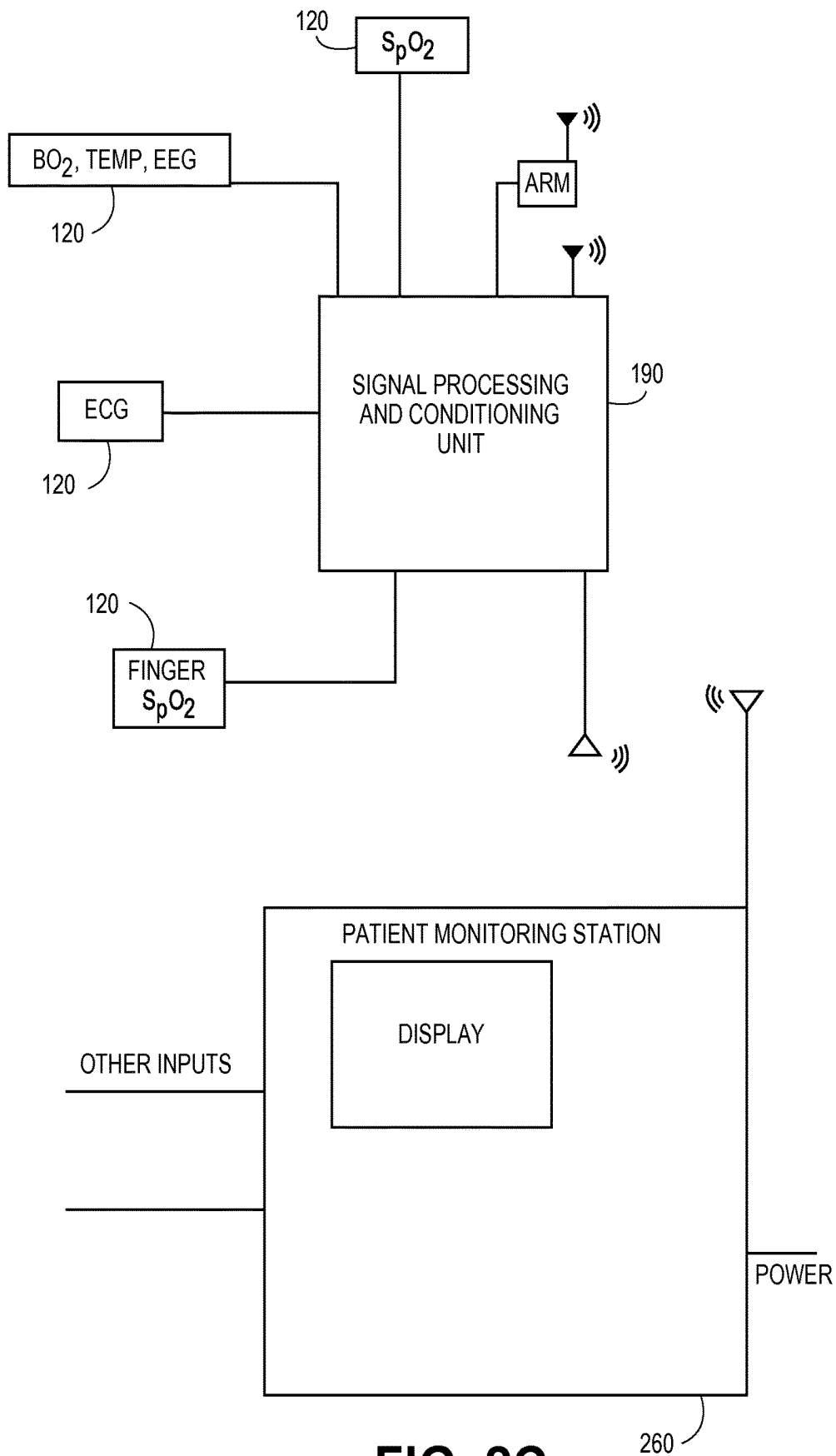

FIG. 2C

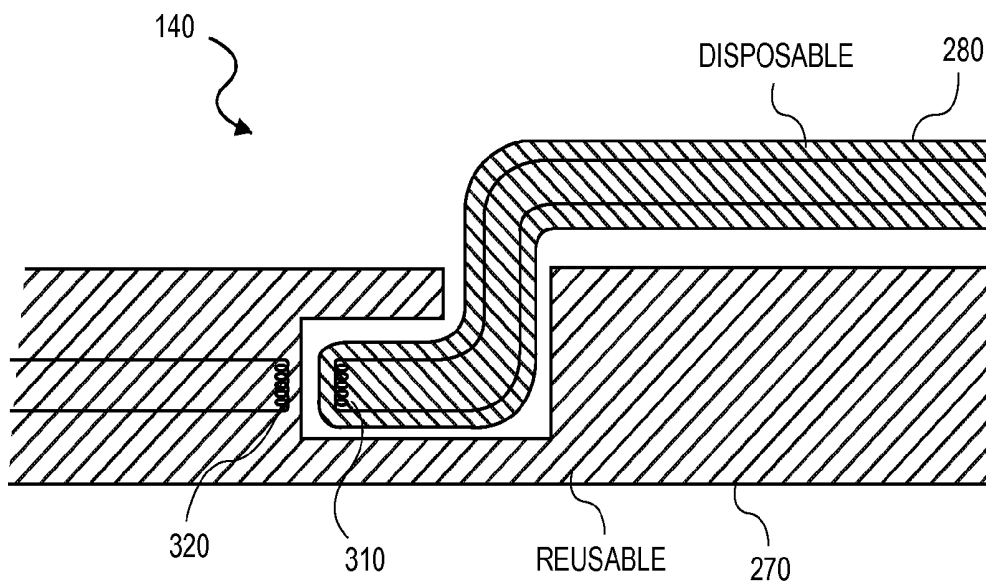

FIG. 3A

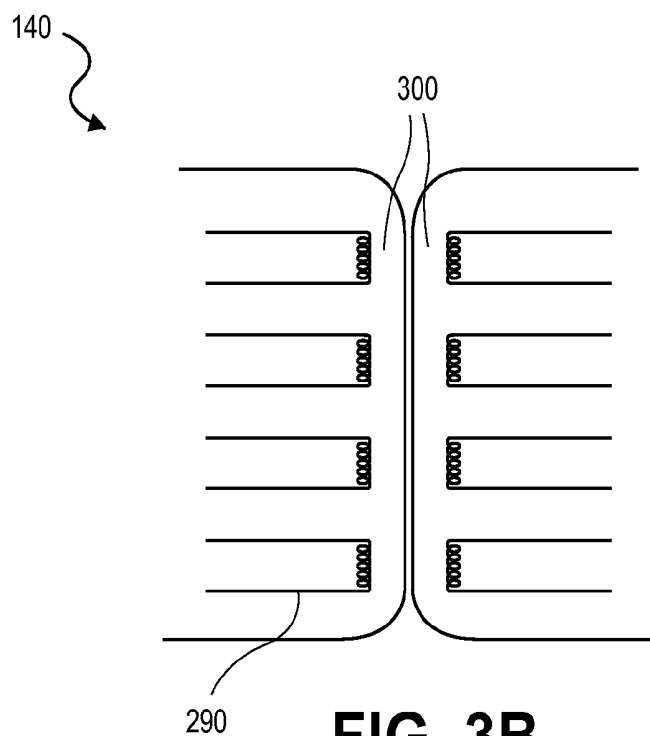
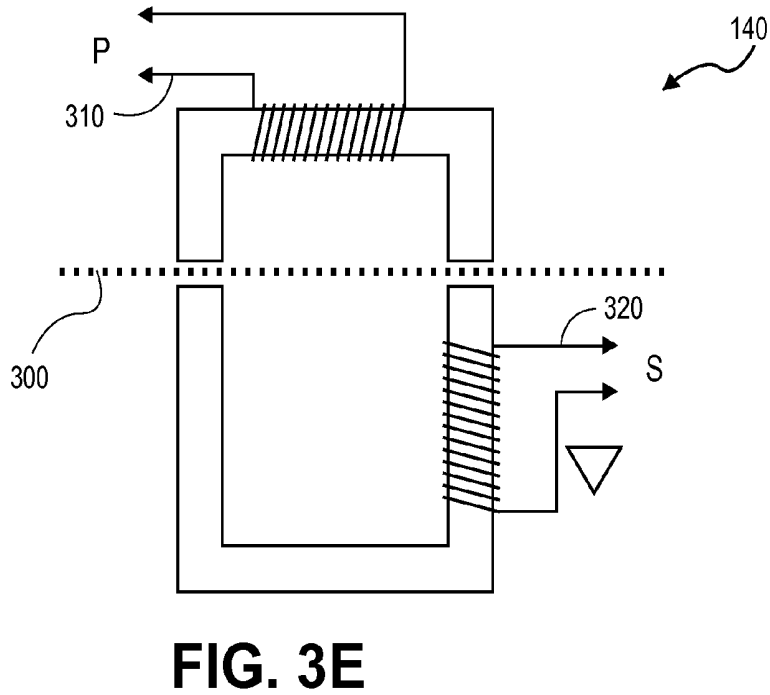
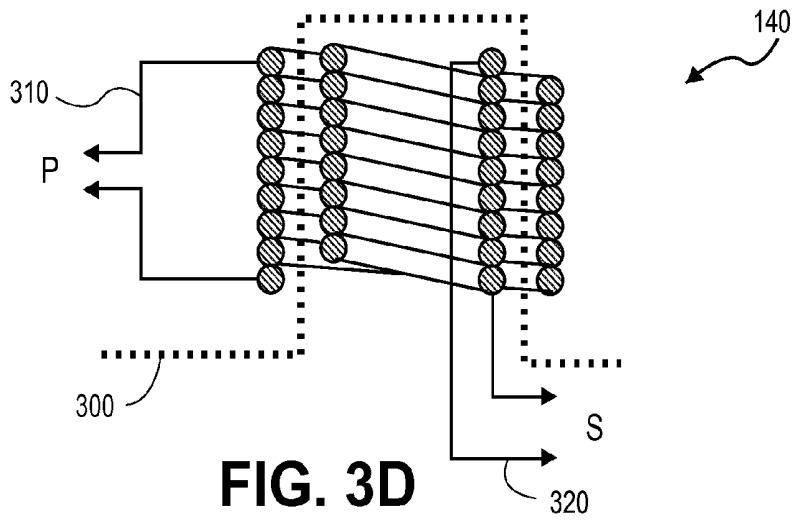
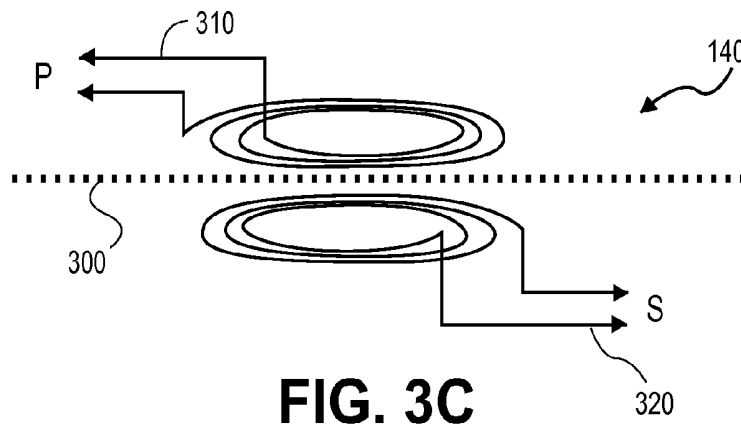
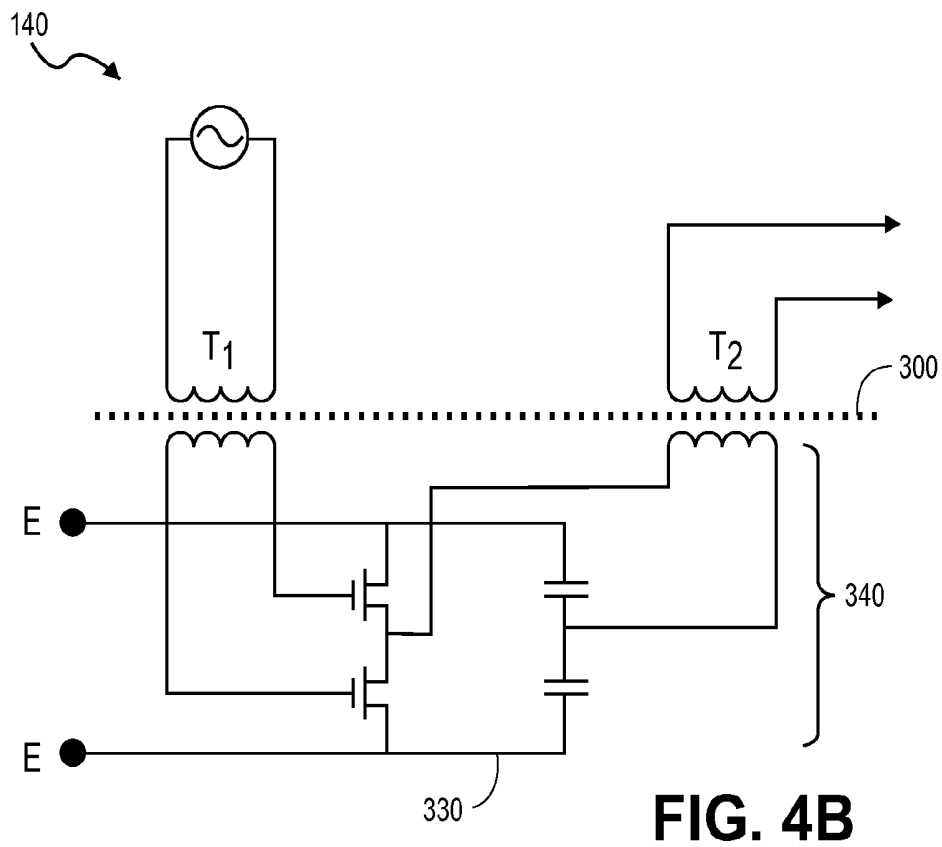
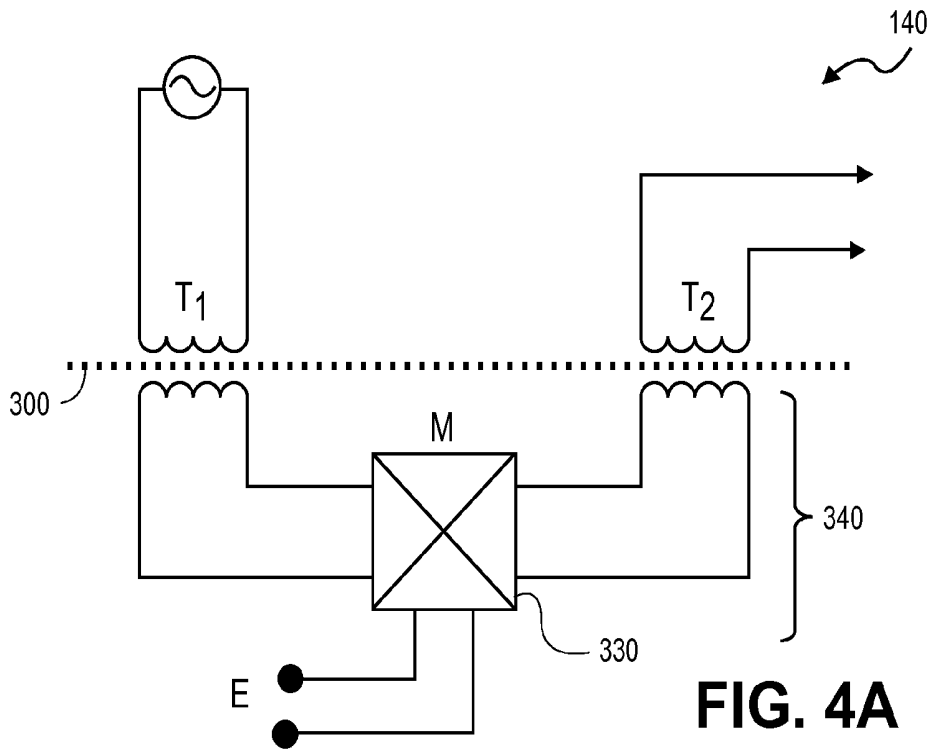

FIG. 3B





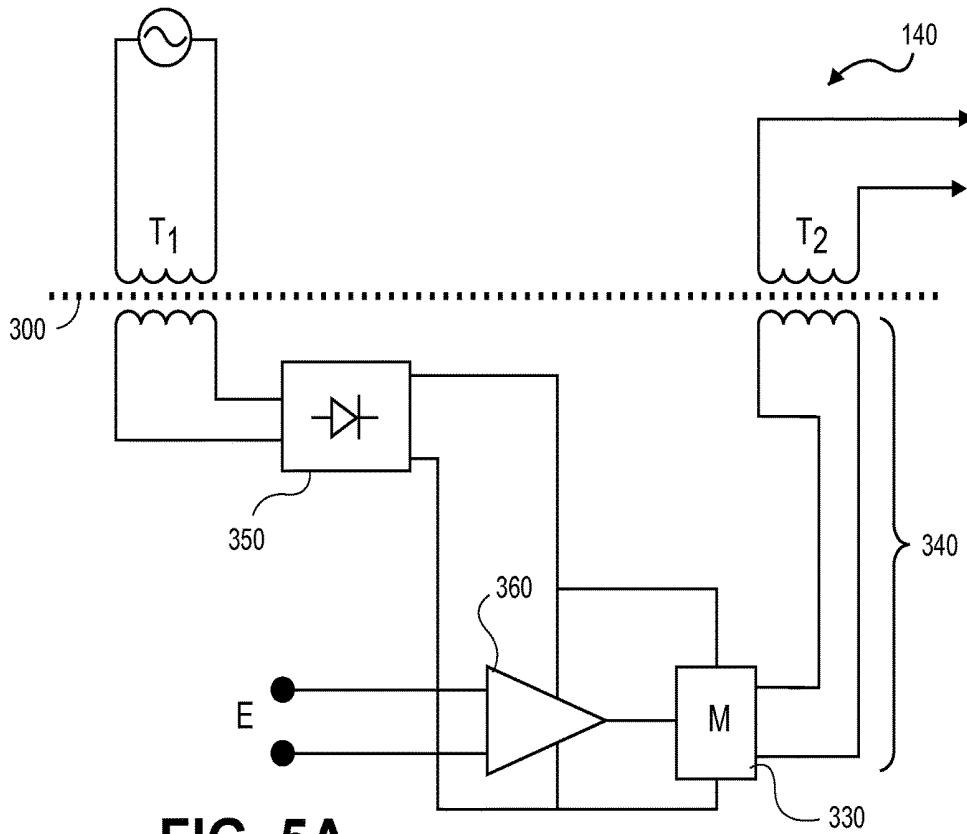

FIG. 5A

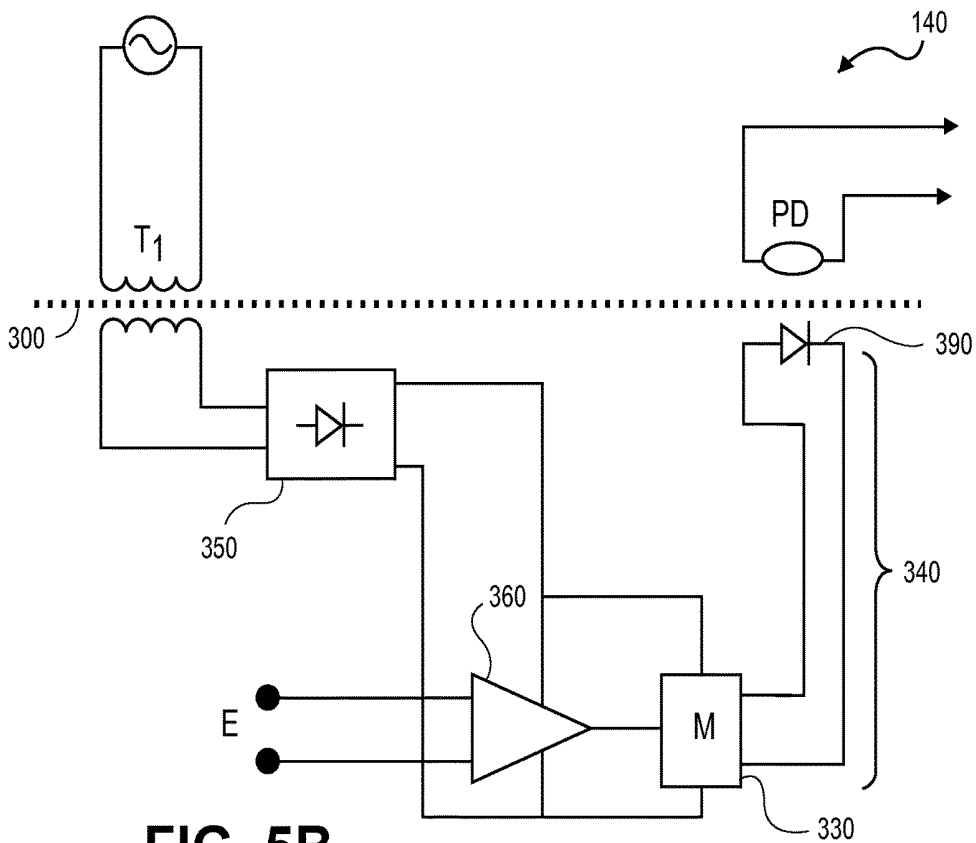

FIG. 5B

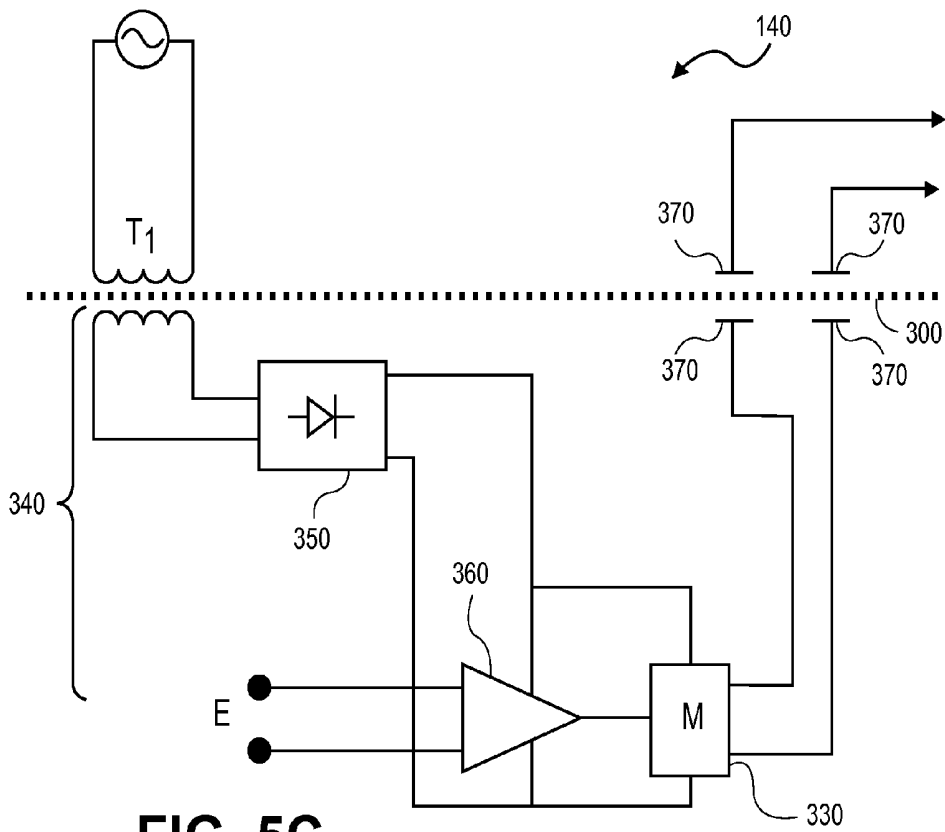

FIG. 5C

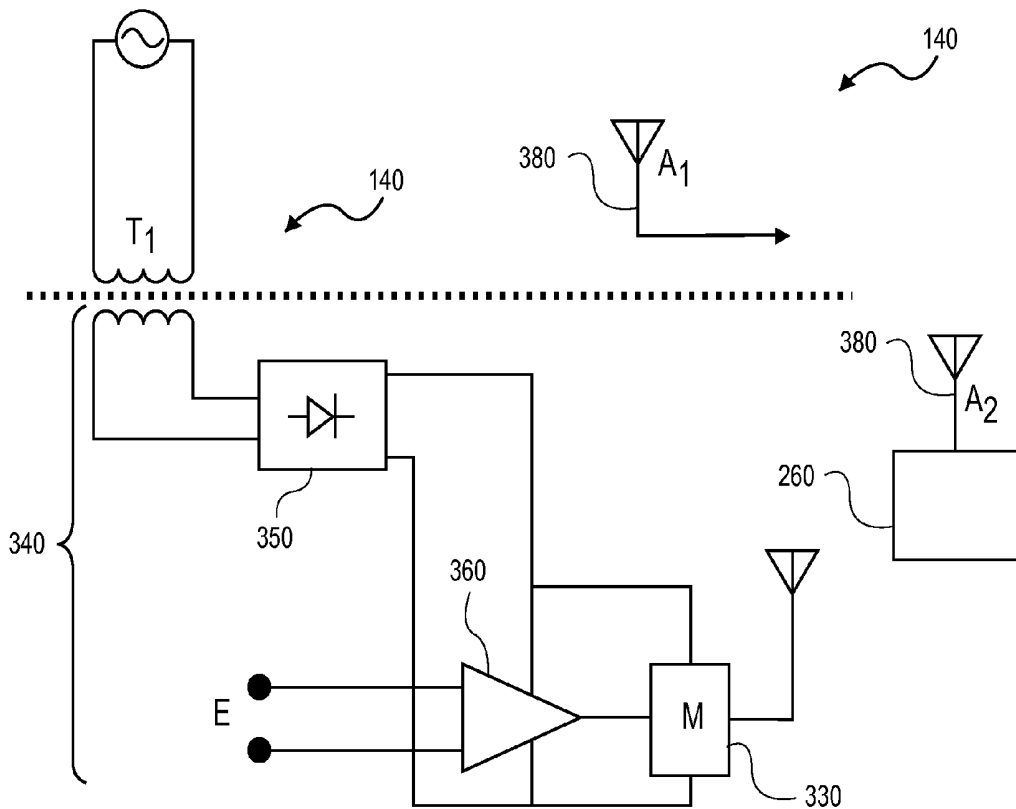

FIG. 5D

MAGNETIC ELECTRICAL CONNECTOR FOR PATIENT MONITORS

PRIORITY CLAIM

This application claims the benefit of priority under 35 U.S.C. §119(e) of the following U.S. Provisional Patent Application No. 61/387,426, titled "Magnetic Electrical Connector For Patient Monitors," filed on Sep. 28, 2010, and incorporates that application by reference herein in its entirety.

REFERENCE TO RELATED APPLICATIONS

This application is related to U.S. Provisional Patent Application No. 61/387,457, titled "Depth of Consciousness Monitor Including Oximeter," filed on Sep. 28, 2010, and incorporates that application by reference herein in its entirety.

FIELD OF THE DISCLOSURE

The present disclosure relates to the field of patient monitoring devices. More specifically, the disclosure relates to electrical connectors for patient monitors adapted to measure blood analyses through optical noninvasive sensors.

BACKGROUND OF THE DISCLOSURE

Electric potentials evoked within a living subject are often sensed with electrodes or assemblies of multiple electrodes placed on the surface of a subject's or patient's body. In many clinical applications, the electric potentials acquired by the electrodes are processed, displayed, and/or recorded by instruments located remotely from the body. In such cases, the electrodes or electrode assemblies communicate with the remote instruments through connecting wires and cables of suitable length from the subject to the instrument.

While the foregoing electrodes are frequently designed to be disposable after use on a single subject, the cables and wires are generally intended to be reused multiple times. The electrodes often include terminals, connectors, or similar assemblies by which they can be detachably connected to the wires and/or cables. The contact surfaces at the points of connection may be subject to contamination, corrosion, or the like, they may cause unreliable connections, or degrade the quality of the bioelectric potentials, which are usually of very low voltage levels. The foregoing connections also may be subject to the ingress of fluids and any fluids entering a connector may degrade its performance. Additionally, many electrical connectors include traditional male and female mechanically matable components where at least one side often includes a cavity, recess, or the like. The cavity or recessed mechanical structures may trap biological contaminants making cleaning and sterilization difficult. Such difficulties may be exacerbated if the cable or wire is used on multiple subjects.

In addition to the foregoing, cables and wires leading from the patient to an instrument also present technical challenges regarding signal integrity. The capacitance between the wires of a given cable may present an undesirable electrical loading on the electrodes. Also, when flexed, cables may evoke triboelectric potentials, which may interfere with the signals of interest. Moreover, cables or wire may pick up electromagnetic interference, which may also degrade the signals of interest.

Often, for safety and signal integrity reasons, an instrument which acquires the electrode potentials generally has its inputs electrically isolated from ground, as well as from other circuits which may contact other parts of the subject. However, a long cable may create significant capacitance to ground, as well as to adjacent cables, at least in part defeating that isolation. The foregoing may lead to signal degradation, often in the form of reduced common-mode rejection. This drawback may be exacerbated where electro-surgical and related RF devices are employed in a subject.

Embodiments of the present disclosure seek to overcome some or all of these and other problems.

SUMMARY OF THE DISCLOSURE

Based on at least the foregoing, the present disclosure seeks to overcome some or all of the drawbacks discussed above and provide additional advantages over any prior technologies. For example, some or all of the foregoing drawbacks may advantageously be mitigated by signal isolation very near the electrodes, such that the electrodes are buffered and/or isolated from the effects of the cable and wiring. In general, designers of electrical components will recognize from the disclosure herein several modalities that accomplish electric signal isolation, including for example, magnetic, optical, or radiofrequency links, and capacitive coupling. An example of magnetic isolation is a transformer having primary and secondary windings separated by an insulating barrier. An optocoupler is an example of an optical isolation device, in which light from an intensity-modulated source passes through an insulating barrier and impinges on a photodetector, which recovers the original modulating signal. A modulated radio transmitter and demodulating receiver are still another example of a signal isolation device.

In an embodiment where the physical separation is large compared to a wavelength of the radio frequency, electromagnetic wave propagation is an operative coupling mechanism. In an embodiment where the transmitter and receiver are located in very close proximity, near-field coupling may be operative. In an embodiment, near-field coupling may be established magnetically by coils having mutual inductance yet insulated from each other, or may be established electrostatically by a small capacitance present across an insulating barrier between the transmitter and receiver circuits. A designer will recognize from the disclosure herein still and other methods. In an embodiment, the near field coupling mechanisms may also be used in conjunction with designs which are not strictly radiofrequency carriers. For example, the ISO721 and related devices, manufactured by Texas Instruments of Dallas, Tex., transmit digital signals across an insulating barrier by means of sensing pulse edges coupled through the tiny capacitance existing across the barrier.

In an embodiment, a device designer can use signal isolation to potentially establish a point of physical disconnection at the location of the insulating barrier. This may allow the designer to create an electrical connector with fewer or no exposed conductive parts. For example, in an embodiment, a transformer may have appropriate electrical characteristics to couple with the signal provided by a pair of electrodes on a subject's body. In an embodiment, the primary winding of this transformer may advantageously be a disposable electrode assembly placed near or on a patient. The cable leading to the instrument could be equipped with a secondary coil. Connection of the cable to the electrode assembly would be accomplished by bringing the coils into physical proximity, such that they are magnetically coupled,

forming a transformer. It is noteworthy that this connection may have fewer or no exposed conductive parts, may be made immune or resistant to the ingress of liquids, and may be designed to be free from small cavities that would entrap biological materials, each reducing the risk of contamination and improving the efficiency and effectiveness of sterilization and signal coupling.

In an embodiment, a device designer can use a system for isolation of electrical components of a physiological monitoring system that comprises a sensor for detecting an indication of a physiological parameter, a patient monitoring system for displaying information transmitted from the sensor, an instrument cable connecting the sensor and the patient monitoring system, a sensor cable connecting the sensory components of the sensor to the instrument cable and a signal isolation coupling located along the sensor cable. This system could utilize an EEG sensor, a pulse oximeter, or a combination cerebral oximeter and EEG forehead sensor. The EEG forehead sensor may include a disposable portion that contains an EEG electrode cable connecting a set of EEG electrodes to the sensor cable. The EEG electrode cable may include a signal isolation coupling which may include an insulating barrier, or inductive components, for example, transformers. In some embodiments, the cerebral oximeter may be reusable.

A device designer may use a forehead sensor for isolation of electrical components of the sensor that includes at least one sensory component for detecting an indication of a physiological parameter of a patient, a sensor cable connected to the at least one sensory component for providing power and communication to the at least one sensory component, and a signal isolation coupling along the sensor cable. The at least one sensory component may be a plurality of EEG electrodes, a cerebral oximeter or pulse oximeter.

In an embodiment, a device designer can use a combination cerebral oximeter and EEG forehead sensor for isolation of electrical components that includes a reusable portion containing cerebral oximetry sensory components capable of detecting the cerebral oxygenation of matter inside the cerebral cavity, a disposable portion containing EEG electrodes capable of detecting electrical activity on a patient's skin, a disposable cable connecting the EEG electrodes to the reusable portion, and a signal isolation coupling connecting the disposable cable to the reusable portion. The sensor's signal isolation coupling may completely surround the signal isolation coupling to allow easy cleaning of the signal isolation coupling.

For purposes of summarizing the disclosure, certain aspects, advantages and novel features of the disclosure have been described herein. Of course, it is to be understood that not necessarily all such aspects, advantages or features will be embodied in any particular embodiment of the disclosure.

BRIEF DESCRIPTION OF THE DRAWINGS

The drawings are provided to illustrate embodiments of the disclosures described herein and do not limit the scope thereof.

FIG. 1A-1E illustrate various patient monitoring devices communicating with optical sensors over cabling and through connections where signal isolation is preferred, according to embodiments of the present disclosure.

FIG. 2A illustrates a simplified block diagram of an embodiment of a pulse oximetry unit, according to the present disclosure.

FIGS. 2B-2C illustrate simplified block diagrams of embodiments of a brain oximetry unit, according to the present disclosure.

FIGS. 3A-3E illustrate various embodiments of signal isolation coupling, according to the present disclosure. For example, FIGS. 3A-3B illustrate a cross-sectional view of an embodiment of the signal isolation coupling including a transformer and separation barriers, according to the present disclosure. FIGS. 3C-3E illustrate various circuit diagrams of an embodiment of the signal isolation coupling including a transformer, according to the present disclosure.

FIGS. 4A-4B illustrate circuit diagrams of a signal isolation connection including a modulator according to an embodiment of the present disclosure.

FIGS. 5A-5D illustrate circuit diagrams of a signal isolation connection including amplification of the bio-potential signals according to an embodiment of the present disclosure.

FIGS. 6-7 illustrate circuit diagrams of a signal isolation connection employing alternate power sources according to an embodiment of the present disclosure.

DETAILED DESCRIPTION OF THE PREFERRED EMBODIMENT

The present disclosure is generally related to signal couplings. In an embodiment, in order to provide an electrical coupling with fewer exposed conductors, and which reduces the ingress of liquids and entrapment of biological materials, an isolation connection is provided utilizing inductance and a physical gap between the conductors of the coupling. In an embodiment, a variety of medical devices could utilize a signal isolation connection between, among other places a sensor or other component interacting with a patient's body and the main instrument. For example, a device designer could implement a signal isolation component between a pulse oximeter and pulse oximetry sensor, an electroencephalogram "EEG" and the EEG electrodes, an electrocardiograph "ECG" and the ECG electrodes, acoustic throat sensors and a respiratory monitor, a temperature probe and a thermometer, and other medical devices with elements that come into close contact with a patient's body.

FIGS. 1A-1E illustrate various embodiments of medical devices that may incorporate a signal isolation coupling as disclosed herein. FIG. 1A illustrates an embodiment of a combination cerebral oximeter and EEG forehead sensor **120** connected by an instrument cable **150** to a conventional pulse oximeter **130**. In this embodiment, a signal isolation coupling **140** could be implemented along the instrument cable **150**, between the connection of the forehead sensor to the sensor cable **160** and the patient electrodes and sensors **170**, or the like.

In an embodiment, the combination EEG and cerebral oximetry forehead sensor **120** may utilize both disposable and reusable components. For example, the disposable portion may advantageously include components near a measurement site surface (the patient's skin), including, for example, an EEG, a temperature sensor, tape, adhesive elements, positioning elements, or the like. The reusable portion may advantageously include more expensive or other components, circuitry and/or electronics. Although the reusable portion may still include time-of-use restrictions for quality control, it may be used multiple times for a single patient, across different patients, or the like. The reusable components may include, for example, cerebral oximetry components, pulse oximetry components and other components to measure other various parameters.

In an embodiment, the connection that connects the disposable portion and the reusable portion of the sensor 120 may be a signal isolation coupling 140 (as shown in FIGS. 3-7) as disclosed herein. The signal isolation coupling 140 (as shown in FIGS. 3-7) could be implemented at any point along either or both of a cable 150 connected to the disposable portion of the sensor 120 and/or a cable 150 connected to a reusable portion of the sensor 120. In one embodiment, the disposable portion of the sensor 120 has a cable 150 connected to it, which in turn has an isolation coupling 140 (as shown in FIGS. 3-7) that connects or communicates with a second cable 150 connected to the reusable portion of the sensor 120. The connection on the cable 150 connected to the reusable portion of the sensor 120 could be at any location along the cable 150 including the connection with the reusable portion of the sensor 120 or the connection to a main cable 150 that interfaces with a medical instrument, such as, for example, an oximeter, a respiration monitor, a blood pressure monitor, or the like.

In an embodiment, a portion of the sensor 120 may communicate with or transmit power with another portion of the sensor 120 or any wire or other electrical connection leading to the signal processing and conditioning unit 190 through a signal isolation coupling 140 (as shown in FIGS. 3-7) as disclosed herein. In an embodiment, the signal isolation coupling 140 (as shown in FIGS. 3-7) could include an inductance connection with transformers embedded near the surface of each half of the connector that are housed by an insulator, for example, plastic. In an embodiment, the two halves of the connector could then be brought in close contact and be removably connected in place to provide a data communication, power connection, or the like.

FIGS. 1B-1E illustrate various additional embodiments of monitoring devices utilizing a finger clip sensor 200 and an instrument, such as, for example, a pulse oximeter 130. In an embodiment, a signal isolation coupling 140 (as shown in FIGS. 3-7) may be implemented in these embodiments in various places along an instrument cable 150 connecting the sensor 120 to the instrument, or in other positions.

FIG. 2A illustrates a block diagram of a pulse oximeter system 210. In an embodiment, a signal isolation coupling 140 as shown in FIGS. 3-7) may be integrated into the system between, for example, the detectors 235 and the front-end interface 220, the emitter 230 and the front end interface 220, the front end interface 220 and the signal processor 240, the signal processor 240 and the network interface 250, or any other part of the system that may benefit from a signal isolation coupling 140 (as shown in FIGS. 3-7). FIG. 2B illustrates an embodiment of a block diagram of a patient monitoring system 260 that includes a pulse oximeter 130, a brain oximetry unit (signal processing and conditioning) 190 for processing and conditioning signals from various sensors, and a variety of sensors 120 for detecting various physiological parameters of a patient. Illustrated are S_pO_2 , EEG, temperature, and brain oximetry sensors 120.

In an embodiment, the sensors 120 may have a front end 220 associated with the sensor 120 included with the brain oximetry unit 190 for controlling the data and power flow between the processor 240 of the brain oximetry unit 190 and the various sensors 120. The front ends 220 communicate drive signals to the various sensors 120 and transmit and/or condition data or signals received from and detected by the sensors 120.

In an embodiment, a signal isolation coupling 140 (as shown in FIGS. 3-7) may be implemented in various places

on the patient monitoring system 260. For example, the signal isolation coupling 140 (as shown in FIGS. 3-7) may be implemented between any of the sensors 120 and its corresponding front end 220, any of the front ends 220 and the processor 240 on the brain oximetry unit 190, between the brain oximetry unit 190 and the conventional pulse oximeter 130, or any other suitable location.

FIG. 2C illustrates an embodiment similar to FIG. 2B including wireless communication with various sensors 120 and between a brain oximetry unit 190 and a monitoring station 260, such as a multiple patient monitoring system or multiple parameter monitoring system.

FIGS. 3-7 illustrate embodiments of signal isolation coupling 140 that may optionally be implemented for various couplings in a medical instrument. In an embodiment, the signal isolation coupling 140 may be achieved through various means including magnetic, optical, radiofrequency links and capacitive coupling. In an embodiment, the magnetic isolation could be a transformer. In another embodiment, an optical coupler could be used for an optical isolation device, in which light from an intensity modulated source passes through an insulating barrier and impinges on a photodetector or other light detector, which recovers the original modulating signal.

In another embodiment, a modulated radio transmitter and demodulation receiver may be implemented to provide a signal isolation coupling 140. In an embodiment where the physical separation is large compared to the wavelength of the radio frequency, electromagnetic wave propagation may be used to provide a coupling connection. In another embodiment, when the transmitter and receiver are located in close proximity, near-field coupling may be used to provide a connection. In an embodiment, near-field coupling may be established magnetically by coils having mutual inductance but insulated from each other, or electrostatically by a small capacitance present across an insulating barrier between the transmitter and receiver circuits. The near field coupling mechanisms may also be used in conjunction with schemes which are not strictly radiofrequency carriers. For example, the ISO721 and related devices, manufactured by Texas Instruments (Dallas, Tex., USA), transmit digital signals across an insulating barrier by means of sensing pulse edges coupled through the tiny capacitance existing across the barrier.

FIG. 3A illustrates an embodiment of a signal isolation coupling 140 connecting the reusable portion 270 and the disposable portion 280 of the combination EEG and cerebral oximetry forehead sensor 120 disclosed herein. The reusable portion 270 and disposable portion 280 of the sensor 210 each have a portion including signal isolation coupling 140 components 290, including transformers to provide an inductance connection. FIG. 3A-3B illustrate an embodiment of the signal isolation coupling 140 with a physical separation between the conductive components.

In an embodiment, an insulating barrier 300 separates the inductive electrical components 290 and provides physical separation between them. In an embodiment, the signal isolation components 290, for example, the transformers, are able to establish an electrical connection across the insulating barrier 300 and physical separation through inductance of the coils. In an embodiment, the insulating barrier 300 provides a connection with fewer or no exposed conductive parts, and insulation of the conductive components by an appropriate electrical insulating material known in the art. In an embodiment, the insulation of the conductive components and reduced exposure of conductive parts allows the

connection to be resistant to the ingress of liquids, and may be designed to be free from small cavities that would entrap biological materials.

In an embodiment, the primary winding **310** of the transformer of the signal isolation coupling **140** could be incorporated in the disposable portion **280** of the sensor **120** or other part of a sensor **120** near the patient interface. As illustrated in FIG. 3A the secondary coil **320** could be included in the reusable portion **270** of the sensor **120** or the instrument cable **150** leading to another medical instrument. In this embodiment, the electrical coupling between the patient interface side and instrument side of the signal isolation coupling **140** could be accomplished by bringing the coils into physical proximity, such that they would be magnetically coupled, forming a complete transformer.

In another embodiment, the connection between the reusable portion **270** of the sensor and the cable **150** leading to the instruments, for example the brain oximetry unit **190**, conventional pulse oximeter **130** and/or other patient monitoring station **260** may be an optical isolation component.

FIG. 3B illustrates an embodiment of the signal isolation connection **140** with several signal isolation components **290**. In one embodiment, the several signal isolation components **290** may be a multitude of transformers placed appropriately to allow the conductors of the primary **310** and secondary coils **320** to be in close proximity with an insulating barrier **300** physically separating the components and preventing direct physical contact between the conductive components of the signal isolation coupling **140**.

Although the physical connection is isolated, the two components may be removably held in proximity to one another through a wide variety of attachment mechanisms, including magnetic, straps with catches, Velcro, matable mechanical components, press fit components, adhesives, fasteners of all types, wraps, bandages, or the like. In an embodiment, the proximity mechanism advantageously provides a sterilizable environment having a reduced number of cavities or the like that may trap contaminants. In an embodiment, the proximity mechanism is entirely disposable.

A signal isolation coupling **140** utilizing transformers may take on several embodiments, exemplary embodiments of which are illustrated in FIGS. 3C-3D. For example, the signal isolation coupling **140** may include of a pair of planar coils, where establishing connection of the electrode assembly to the cable includes bringing the coils into proximity face-to-face. An embodiment of this construction is shown in FIG. 3C where the primary coils **310** and secondary planar coils **320** have terminals labeled P and S respectively. The dotted line represents the insulating barrier **300** between the coils, and is also the division along which coils may be separated when the signal isolation coupling **140** is decoupled.

FIG. 3D illustrates an embodiment of a cross-section of a transformer with a pair of co-axial solenoid coils. The heavy dotted line represents the insulating barrier **300** between the coils, and is also the division along which the coils may be separated when the signal isolation coupling **140** is decoupled. In an embodiment, an electrical connection may be established by inserting one coil within the other, and disconnected by drawing the coils apart. In either of these embodiments, a magnetic core may be added to enhance the coupling already present between the coils. FIG. 3E illustrates an embodiment in which the primary coils **310** and secondary coils **320** are not oriented so as to be coupled directly. In this embodiment, a separable magnetic core may

be provided to couple the coils when the two parts are brought in proximity of each other.

Bio-potential signals often have low frequencies, often less than about 1 Hz, and tend to be sourced from fairly high impedances. In an embodiment, coupling a signal of this nature may require a transformer having relatively large inductance. A further challenge is that bio-potential signals tend to have relatively small amplitudes, in the millivolt or microvolt range. A transformer configured to pass signals with such characteristics may tend to act as a pickup coil for stray magnetic fields in the vicinity of the subject, such as mains-frequency magnetic fields. In an embodiment, however, various devices may convert the bio-potential signal into a form more suitable for passing through a practical separable transformer or other separable isolation device before passing the signals through the signal isolation coupling **140**. In an embodiment, this may be accomplished by adding various electronic circuits to the electrode assembly.

One such embodiment of an electrical system designed to condition a bio-potential signal for passing through a signal isolation coupling **140** utilizing transformers includes a modulator circuit to convert the low-frequency bio-potential signal into a high frequency signal, better suited to be passed through a small and practical separable transformer. In one form of this embodiment, a pair of separable transformers is used, as seen in FIG. 4A. In this embodiment, the electrode assembly **340** including the electrodes E has been equipped with a modulator **330** and one winding each of the transformers T1 and T2. In an embodiment, the transformer T1 passes a carrier frequency excitation from the instrument cable **150** to the electrode assembly. The modulator **330** may then modulate this carrier frequency with the bio-potential signal applied at the electrodes E. The modulated signal is then passed back to the instrument cable through the transformer T2. Both transformers may be of any of the separable forms described herein or other suitable transformers known in the art from the disclosure herein, such that the electrode assembly **340** may be detached from the instrument cable **150** along the dotted line. In embodiments where multiple bio-potential signal channels are involved, a single excitation transformer may be used to serve all channels. The modulator **330** may include of a simple circuit, having no power supply, other than the carrier signal itself. Examples of these suitable modulators **330** would be modulators using diode or transistor switches in any of the many circuit configurations well known in the art from the disclosure herein of constructing modulator and mixer circuits. FIG. 4B illustrates one exemplary modulator **330** circuit topology employing MOSFET switches. This circuit provides simplicity and economy of cost and is readily adaptable to a disposable electrode assembly. However, other embodiments of modulator **330** are possible, and with the application of integrated circuit technology, may be made suitably compact and inexpensive for practical use.

Another embodiment utilizes a single separable transformer to address the difficulties of bio-potential signals. In this embodiment, the electrode assembly **340** includes a parametric modulator circuit connected to the secondary coil of the separable transformer. In an embodiment, the parametric modulator may include of diodes, varactor diodes, or other non-linear devices which change impedance as a function of the bio-potential signals. The bio-potential signal may be observed by measuring the impedance reflected through the separable transformer when an excitation is applied to the transformer's primary coil. In another embodiment, the parametric modulator may generate a harmonic or sub-harmonic of the excitation signal, the amplitude of this

harmonic or sub-harmonic being modulated by the bio-potential signal, and being observable at the primary side of the separable transformer.

In an embodiment, as discussed herein, the bio-potential signals may be a relatively small amplitude, and it thus may be advantageous to amplify these signals before passing them into the modulator 330 or other similar circuit. Illustrated in FIG. 5A is an embodiment of an amplification circuit designed to be applied to a modulation circuit or directly to a transformer circuit. Shown is the transformer T1 equipped with a rectifier 350, which provides a DC supply voltage to the sensor 120 or other instrumentation device. This voltage supplies an amplifier 360, which amplifies the bio-potential signal acquired by the electrodes E. In an embodiment, the amplified signal is then applied to the modulator 330, which returns a modulated signal to the instrument cable 150 by means of the transformer T2.

However, as a power supply voltage is now available to the modulator 330, it may have an expanded scope of operation as compared to the embodiment illustrated in FIGS. 4A-4B. For example, it may modulate the carrier frequency supplied through T1, as before. However, it may develop its own, different carrier frequency, and may use any manner of various modulation schemes, such as amplitude, phase, or frequency modulation. In an embodiment, it may include an analog to digital converter, digital signal processing, and other functions and circuits, such that its output is a digital representation of the original bio-potential signal. This digital representation may be coupled directly through the transformer T2 or may be modulated, by any of the various means known in the art, on a carrier signal before being passed through the transformer T2.

In other embodiments of the signal isolation coupling 140, the transformer T2 may be replaced with other types of devices. For example, the receiving coil of the transformer T2 may be replaced with some other suitable magnetic sensor, such as a GMR device. In another embodiment, the receiving coil of the transformer T2 may be replaced with some coupling device(s) not operating on a magnetic principle. For example, FIG. 5B illustrates the use of an optical coupling scheme, where the modulator 330 drives an LED or other optical light source 390, the radiation from which impinges on the photodetector PD which is integrated into the instrument cable 150. The dotted line indicates the insulating barrier 300 and the physical separation of the signal isolation coupling 140. In an embodiment, the material of the insulating barrier 300 may be substantially transmissive of the radiation of the light source 390.

In the case of an optical link, the modulator 330 may not be necessary, since the optical link can be designed to have adequate low frequency response, such that the baseband bio-potential signal can be directly passed. In another embodiment, as illustrated in FIG. 5C, an electrostatic coupling is created using the capacitance between small coupling conductors 370 placed on opposite sides of the insulating barrier 300. In another embodiment, the modulator 330 includes an antenna 380 to transmit its output and/or receive input instructions, as seen in FIG. 5D. The radiated signal may be received either by an antenna A1 located in close proximity in the instrument cable connector 140, or by an antenna A2 located remotely, such as within a remote patient monitoring station 260. In this latter case, in an embodiment, the instrument cable 150 may be used to supply power to the electronics within the electrode assembly 340, while the return of the bio-potential is transmitted wirelessly.

In the embodiment shown in FIGS. 5A-5D it is possible to operate the system without the transformer T1 and the rectifier 350. In an embodiment, the disposable portion 280 of the sensor 120 may operate only for a short period of time, such as for the duration of a particular medical procedure. In another embodiment, where long term monitoring of the bio-potential signal may be desired, the electrodes may have a finite lifetime, for example, due to drying out and similar chemical effects. Therefore, the power supplied by the transformer T1 and the rectifier 350 may instead be obtained from a small battery imbedded, for example, in the disposable portion 280 of the sensor 120. By the use of suitable low power electronic design techniques, balanced with appropriate selection of the battery type, sufficient battery life for many limited-time applications of the disposable portion 280 of the sensor 120 can be obtained. The coupling modalities illustrated in the various parts of FIGS. 5A-5D may also be adapted to battery operation. However, some have lower power requirements than others, and therefore may be better suited to particular intended service durations.

In the embodiments illustrated in the various parts of FIGS. 5A-5D, with either transformer or battery power, multiple channels of bio-potential signals obtained from additional electrodes may be multiplexed through a single coupling device of any of the types illustrated.

As illustrated in FIG. 6, it is possible to avoid the use of a battery while using a single coupling device for the signal isolation coupling 140. In an embodiment, the transformer T1 may serve as the coupling device. In this embodiment, the primary coil 310 and secondary coil 320 of the transformer T1 may be equipped with 3-port networks Np and Ns respectively. These are duplexing networks, which allow the power and modulated data to pass independently in opposite directions through the transformer T1. For example, in an embodiment, where the modulator 330 uses a carrier frequency higher than the power frequency, the networks would take the form of filters having high pass and low pass ports. In that embodiment, the networks Ns would extract the power through the low-pass port and apply it the rectifier 350. The modulator 330 would feed its output back through the high-pass port. Also, the network Np would apply power through its low-pass port and extract the modulator 330 signal through the high-pass port. Note that the modulated signal may be either an analog or digital representation of the bio-potential signal. Further, note that multiple bio-potential channels, from additional electrodes, may be multiplexed in either analog or digital format through the single transformer.

FIG. 7 illustrates another embodiment of a signal isolation coupling 140 which duplexes both power and signal through a single transformer. Shown is the output of the modulator 330 being used to operate a load device. In an embodiment, the load device then presents a variable load to the DC power developed by the rectifier 350, in response to the modulated output. In FIG. 7, this is represented as transistor Q. The modulator 330 output is therefore reflected on the power supply current passed through the transformer T1, and may be recovered by monitoring this current. For example, an impedance Z placed in the power excitation circuit will develop a voltage representative of the modulator signal. Note that this is possible to eliminate the modulator 330, and apply the amplified baseband bio-potential signal to Q. In this embodiment, the supply current becomes modulated with the baseband signal, and impedance Z recovers an AM modulated voltage representative of the

original biopotential signal. In an alternate embodiment, the load device maybe designed to be operated with an AC voltage.

Although the foregoing disclosure has been described in terms of certain preferred embodiments, other embodiments will be apparent to those of ordinary skill in the art from the disclosure herein. Additionally, other combinations, omissions, substitutions and modifications will be apparent to the skilled artisan in view of the disclosure herein. Accordingly, the present disclosure is not intended to be limited by the reaction of the preferred embodiments, but is to be defined by reference to the appended claims.

In an embodiment, a device designer can use a system for isolation of electrical components of a physiological monitoring system that comprises a sensor for detecting an indication of a physiological parameter, a patient monitoring system for displaying information transmitted from the sensor, an instrument cable connecting the sensor and the patient monitoring system, a sensor cable connecting the sensory components of the sensor to the instrument cable and a signal isolation coupling located along the sensor cable. This system could utilize an EEG sensor, a pulse oximeter, or a combination cerebral oximeter and EEG forehead sensor. The EEG forehead sensor may include a disposable portion that contains an EEG electrode cable connecting a set of EEG electrodes to the sensor cable. The EEG electrode cable may include a signal isolation coupling which may include an insulating barrier, or inductive components, for example, transformers. In some embodiments, the cerebral oximeter may be reusable.

A device designer may use a forehead sensor for isolation of electrical components of the sensor that includes at least one sensory component for detecting an indication of a physiological parameter of a patient, a sensor cable connected to the at least one sensory component for providing power and communication to the at least one sensory component, and a signal isolation coupling along the sensor cable. The at least one sensory component may be a plurality of EEG electrodes, a cerebral oximeter or pulse oximeter.

In an embodiment, a device designer can use a combination cerebral oximeter and EEG forehead sensor for isolation of electrical components that includes a reusable portion containing cerebral oximetry sensory components capable of detecting the cerebral oxygenation of matter inside the cerebral cavity, a disposable portion containing EEG electrodes capable of detecting electrical activity on a patient's skin, a disposable cable connecting the EEG electrodes to the reusable portion, and a signal isolation coupling connecting the disposable cable to the reusable portion. The sensor's signal isolation coupling may completely surround the signal isolation coupling to allow easy cleaning of the signal isolation coupling.

Additionally, all publications, patents, and patent applications mentioned in this specification are herein incorporated by reference to the same extent as if each individual publication, patent, or patent application was specifically and individually indicated to be incorporated by reference.

What is claimed is:

1. A system for connecting a sensor using isolation of electrical components comprising:

- a noninvasive optical sensor including a light source configured to emit light and a detector configured to detect the light after attenuation by body tissue at a measurement site;
- an EEG sensor comprising a plurality of EEG electrodes configured to detect a bioelectric signal from a patient;

a first cable including a first plurality of conductors electrically connected to the EEG sensor and the non-invasive optical sensor;

a second cable including a second plurality of conductors coupled to a patient monitoring system; and

a signal isolation coupling comprising:

- a first electrical element inside the first cable and forming a part of the first cable, said first electrical element electrically connected to said first plurality of conductors via a modulator circuit inside the first cable, wherein said modulator circuit is configured to transform low frequency signals carried by the first plurality of conductors to high frequency signals;

- a first insulating barrier inside the first cable protecting the first portion;

- a second electrical element inside the second cable and forming a part of the second cable, said second electrical element electrically connected to the second plurality of conductors, said second plurality of conductors configured to carry said high frequency signals received by the second electrical element from the first electrical element over a physical separation between the first cable and the second cable, wherein said second cable is configured to detachably connect with the first cable at the physical separation; and

- a second insulating barrier inside the second cable protecting the second portion;

wherein the first cable comprises a cavity configured to receive the second cable and electrically couple with the second cable at the physical separation with no exposed conductors, the cavity comprising a first section and a second section, the first section perpendicular to the second section, and wherein the cavity is configured to secure the first cable with the second cable through the first and the second sections.

2. The system of claim 1 further comprising an attachment mechanism configured to removably hold the first cable proximate the second cable and configured to orient the first electrical element to couple with the second electrical element.

3. The system of claim 2, wherein the attachment mechanism comprises matable mechanical components.

4. The system of claim 1, wherein the first electrical element comprises a first coil and wherein the second electrical element comprises a second coil responsive to the first coil.

5. A system for connecting a sensor using isolation of electrical components comprising:

- a first cable comprising:

- one or more first conductors electrically coupled to a sensor configured to detect low voltage signals;

- a first electrical element coupled to the one or more first conductors and transfer the detected low voltage signal across a gap; and

- a first insulating barrier configured to insulate the first electrical element; a second cable comprising:

- one or more second conductors electrically coupled to a patient monitor;

- a second electrical element coupled to the one or more second conductors and configured to receive the transferred detected low voltage signals across the gap; and
- a second insulating barrier configured to insulate the second electrical element; and

the first cable comprises an attachment mechanism configured to removable secure the first cable with the second cable, the attachment mechanism comprises a

13

cavity comprising a first section and a second section,
the first section perpendicular to the second section,
wherein the cavity is configured to secure the first cable
with the second cable through the first and the second
sections;
wherein the one or more first conductors and the first
electrical element are isolated from the one or more
second conductors and the second electrical element.

5

* * * * *

14

专利名称(译)	用于患者监护仪的磁性电连接器		
公开(公告)号	US9775545	公开(公告)日	2017-10-03
申请号	US13/246768	申请日	2011-09-27
[标]申请(专利权)人(译)	AL ALI AMMAR KINAST ERIC KARL		
申请(专利权)人(译)	AL-ALI AMMAR KINAST ERIC KARL		
当前申请(专利权)人(译)	Masimo公司		
[标]发明人	AL ALI AMMAR KINAST ERIC KARL		
发明人	AL-ALI, AMMAR KINAST, ERIC KARL		
IPC分类号	A61B5/00 A61B5/1455 A61B5/0476		
CPC分类号	A61B5/14551 A61B5/0476 A61B5/14553 A61B5/6814 A61B2562/227 A61B2562/245		
优先权	61/387426 2010-09-28 US		
其他公开文献	US20120088984A1		
外部链接	Espacenet USPTO		

摘要(译)

本公开涉及一种用于在生理监测系统的各种部件之间提供信号隔离的电连接器。在一个实施例中，电连接器放置在传感器和相关联的监控系统之间，并且包括物理屏障和电感组件。

