



US009237850B2

(12) **United States Patent**  
**Metzger et al.**

(10) **Patent No.:** **US 9,237,850 B2**  
(45) **Date of Patent:** **Jan. 19, 2016**

(54) **SYSTEM AND METHOD FOR  
NONINVASIVELY MONITORING  
CONDITIONS OF A SUBJECT**

(75) Inventors: **Yaacov Metzger**, Hod Hasharon (IL);  
**Michal Rokni**, Zichron Ya'akov (IL);  
**Revital Pery-Shechter**, Rishon Lezion  
(IL)

(73) Assignee: **OR-NIM MEDICAL LTD.**, Lod (IL)

(\* ) Notice: Subject to any disclaimer, the term of this  
patent is extended or adjusted under 35  
U.S.C. 154(b) by 920 days.

(21) Appl. No.: **13/402,275**

(22) Filed: **Feb. 22, 2012**

(65) **Prior Publication Data**

US 2012/0150014 A1 Jun. 14, 2012

**Related U.S. Application Data**

(63) Continuation of application No. 12/475,695, filed on  
Jun. 1, 2009, now Pat. No. 8,143,605, which is a  
continuation of application No. 11/757,698, filed on  
Jun. 4, 2007, now Pat. No. 7,541,602.

(51) **Int. Cl.**  
**A61B 8/00** (2006.01)  
**A61B 5/00** (2006.01)  
(Continued)

(52) **U.S. Cl.**  
CPC ..... **A61B 5/0059** (2013.01); **A61B 5/0097**  
(2013.01); **G01N 21/1702** (2013.01); **A61B**  
**5/1455** (2013.01)

(58) **Field of Classification Search**  
CPC ..... A61B 8/00  
USPC ..... 600/407, 437, 439, 473, 476  
See application file for complete search history.

(56) **References Cited**

U.S. PATENT DOCUMENTS

3,435,228 A 3/1969 Gordon  
4,059,010 A 11/1977 Sachs  
(Continued)

FOREIGN PATENT DOCUMENTS

DE 19654053 A1 6/1998  
EP 0549835 A1 7/1993  
(Continued)

OTHER PUBLICATIONS

D. M. Hueber et al., "Non-invasive and quantitative near-infrared  
haemoglobin spectrometry in the piglet brain during hypoxic stress,  
using a frequency-domain multidistance instrument", *Phys. Med.  
Biol.* 46 (2001) 41-62.

(Continued)

*Primary Examiner* — Peter Luong

(74) *Attorney, Agent, or Firm* — Browdy and Neimark,  
PLLC

(57) **ABSTRACT**

A method and system are presented for use in determining  
one or more parameters of a subject. A region of interest of the  
subject is irradiated with acoustic tagging radiation, which  
comprises at least one acoustic tagging beam. At least a  
portion of the region of interest is irradiated with at least one  
electromagnetic beam of a predetermined frequency range.  
Electromagnetic radiation response of the at least portion of  
the region of interest is detected and measured data indicative  
thereof is generated. The detected response comprises elec-  
tromagnetic radiation tagged by the acoustic radiation. This  
enables processing of the measured data indicative of the  
detected electromagnetic radiation response to determine at  
least one parameter of the subject in a region corresponding to  
the locations in the medium at which the electromagnetic  
radiation has been tagged by the acoustic radiation, and out-  
putting data indicative of the at least one determined param-  
eter.

**16 Claims, 13 Drawing Sheets**

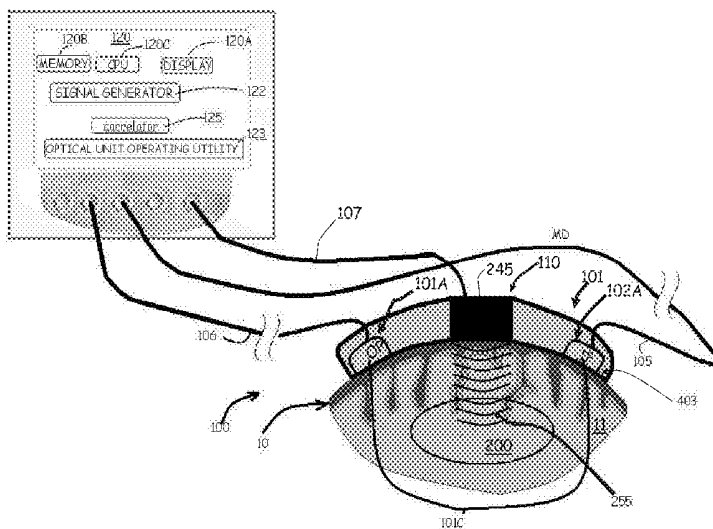

- (51) **Int. Cl.**  
**G01N 21/17** (2006.01)  
**A61B 5/1455** (2006.01)

(56) **References Cited**

U.S. PATENT DOCUMENTS

4,109,647 A 8/1978 Stern et al.  
4,653,498 A 3/1987 New, Jr. et al.  
5,152,293 A 10/1992 Vonesh et al.  
5,193,543 A 3/1993 Yelderman  
5,293,873 A 3/1994 Fang  
5,299,570 A 4/1994 Hatschek  
5,494,032 A 2/1996 Robinson et al.  
5,529,073 A 6/1996 Kielbasiewicz  
5,579,774 A 12/1996 Miller et al.  
5,713,364 A 2/1998 DeBaryshe et al.  
5,738,635 A 4/1998 Chapelon et al.  
6,002,258 A 12/1999 Mercer  
6,041,248 A 3/2000 Wang  
6,047,602 A 4/2000 Lynnworth  
6,216,538 B1 4/2001 Yasuda et al.  
6,240,309 B1 5/2001 Yamashita et al.  
6,264,610 B1 7/2001 Zhu  
6,456,862 B2 9/2002 Benni  
6,498,942 B1 12/2002 Esenaliev et al.  
6,590,830 B1 7/2003 Garlick et al.  
6,615,065 B1 9/2003 Barrett et al.  
6,690,958 B1 2/2004 Walker et al.  
6,738,653 B1 5/2004 Sfez et al.  
6,802,812 B1 10/2004 Walker et al.  
6,815,694 B2 11/2004 Sfez et al.  
6,957,096 B2 10/2005 Sfez et al.  
7,048,687 B1 5/2006 Reuss et al.  
7,049,622 B1 5/2006 Weiss  
7,229,411 B2 6/2007 Slayton et al.  
7,251,518 B2 7/2007 Herrmann  
7,340,957 B2 3/2008 Kaduchak et al.  
7,541,602 B2 6/2009 Metzger et al.  
7,747,301 B2 6/2010 Cheng et al.  
8,108,022 B2 1/2012 Balberg et al.  
8,126,524 B2 2/2012 Balberg et al.  
2002/0017141 A1 2/2002 Satoh  
2002/0067269 A1 6/2002 Cadell et al.  
2003/0018246 A1 1/2003 Govari et al.  
2004/0127782 A1 7/2004 Sfez et al.  
2005/0038344 A1 2/2005 Chance  
2005/0215901 A1 9/2005 Anderson et al.  
2006/0122475 A1 6/2006 Balberg et al.  
2006/0247506 A1 11/2006 Balberg et al.  
2007/0093702 A1 4/2007 Yu et al.  
2008/0200787 A1 8/2008 Shapira et al.  
2008/0296514 A1 12/2008 Metzger et al.  
2008/0312533 A1\* 12/2008 Balberg et al. .... 600/437

FOREIGN PATENT DOCUMENTS

EP 1008326 A2 6/2000  
EP 1810610 A1 7/2007

WO 98/50781 A1 11/1998  
WO 99/58060 A1 11/1999  
WO 02/08740 A2 1/2002  
WO 02/17779 A1 3/2002  
WO 03/057061 A1 7/2003  
WO 2005/025399 A2 3/2005  
WO 2006/097910 A1 9/2006  
WO 2008/039195 A1 4/2008

OTHER PUBLICATIONS

A. Lev et al., "In vivo demonstration of the ultrasound-modulated light technique", J. Opt. Soc. Am. A vol. 20, No. 12 (Dec. 2003).  
G. Yu et al., "Time-dependent blood flow and oxygenation in human skeletal muscles measured with noninvasive near-infrared diffuse optical spectroscopies", Journal of Biomedical Optics 10:2 Mar./Apr. 2005, 024027-1/024027-12.  
Brown D.W. et al., "Near-Infrared Spectroscopy Measurement of Oxidation Fraction and Cerebral Metabolic Rate of Oxygen in Newborn Piglets", Pediatric Research vol. 54, No. 6, 2003 pp. 861-867.  
M. E. Raichle et al., "Brain work and brain imaging", Annu Rev Neurosci 2006; 29:449-476.  
S. Takatani et al., "Theoretical analysis of diffuse reflectance from a two-layer tissue model," IEEE Trans. Biomed. Eng., BME-26, 656-664, (1979).  
Prahl, "Optical Absorption of Hemoglobin", OMLC, SAP (Jun. 1998).  
Lev A. et al., "Direct, noninvasive detection of photon density in turbid media" Optics Letters (2002) 27 (7) 473-475.  
Leveque-Fort et al., "In situ local tissue characterization and imaging by backscattering acousto-optic imaging" in Optics Communication 196 127-131 (2001).  
Keinle et al., "In vivo determination of the optical properties of muscle with time-resolved reflectance using a layered model" in Physics in Medicine and Biology 44: 2689-2702 (1999).  
A. Zourabian et al., "Trans-abdominal monitoring of fetal arterial blood oxygenation using pulse oximetry" Journal of Biomedical Optics 5(4), 391-405 (2000).  
B. Chance et al., "Optical investigations of physiology: a study of intrinsic and extrinsic biomedical contrast" Phil. Trans. R. Soc. Lond. B (1997) 352, pp. 707-716].  
F. Rousseau et al., "Calibration Method for 3D Freehand Ultrasound", in Medical Image Computing and Computer Assisted Intervention, MICCAI'03, Montreal, Canada, Nov. 2003.  
Wang et al, L. V., "Frequency-swept ultrasound-modulated optical tomography of scattering media", Optics Letter, Optical Society, vol. 23, No. 12, Jun. 12, 1998, pp. 975-977.  
Yao et al., G., "Frequency-swept ultrasound-modulated optical tomography in biological tissue by use of parallel detections", Optics Letters, The Optical Society, vol. 25, No. 10, Jun. 15, 2000, pp. 734-736.  
Lev et al., A., "Pulsed ultrasound-modulated light tomography", Optics Letters, vol. 28, No. 17, Sep. 1, 2003, p. 1549.  
European Search report for European Appln. No. 08763502.5 dated Jan. 20, 2014.

\* cited by examiner

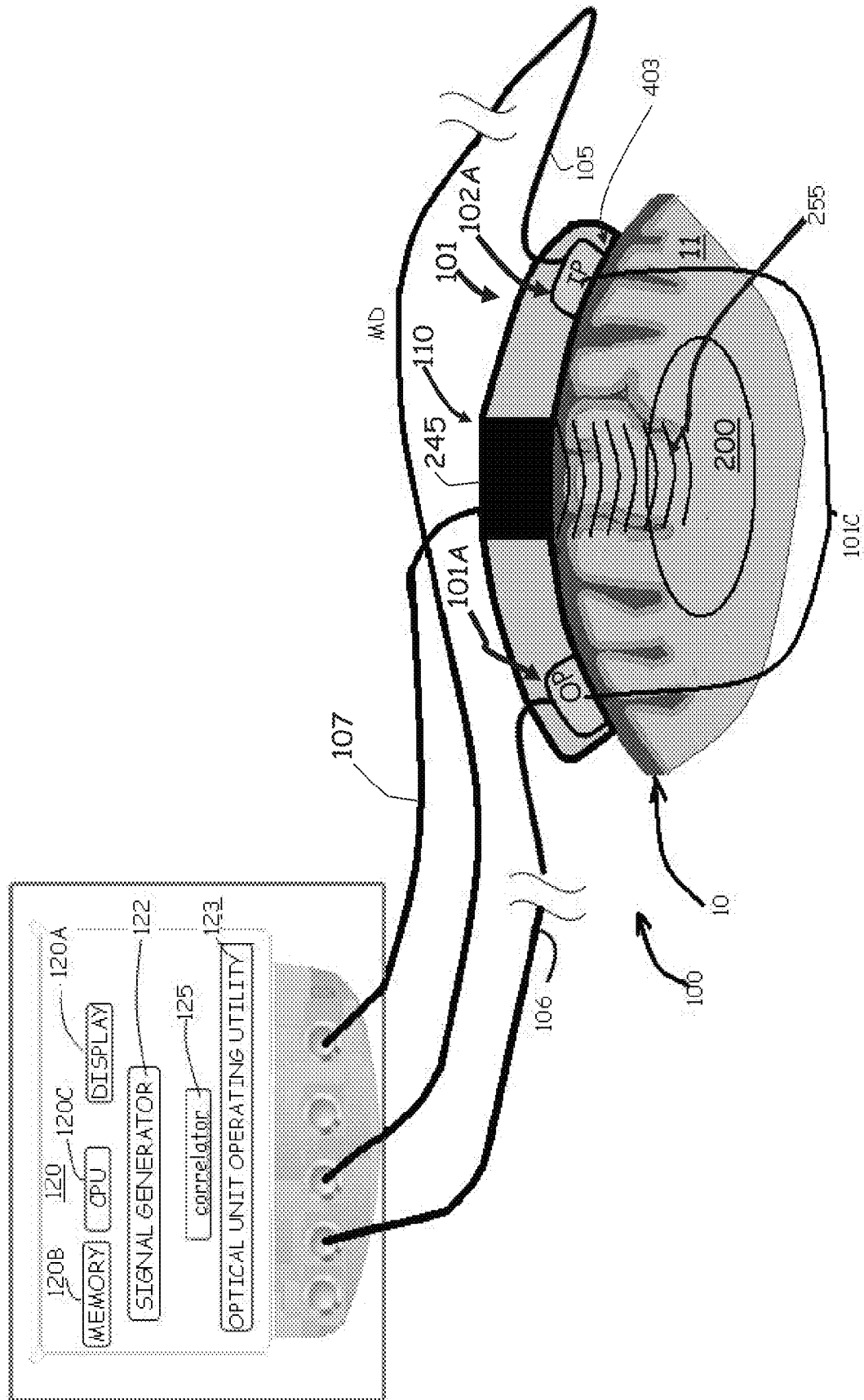

FIGURE 1

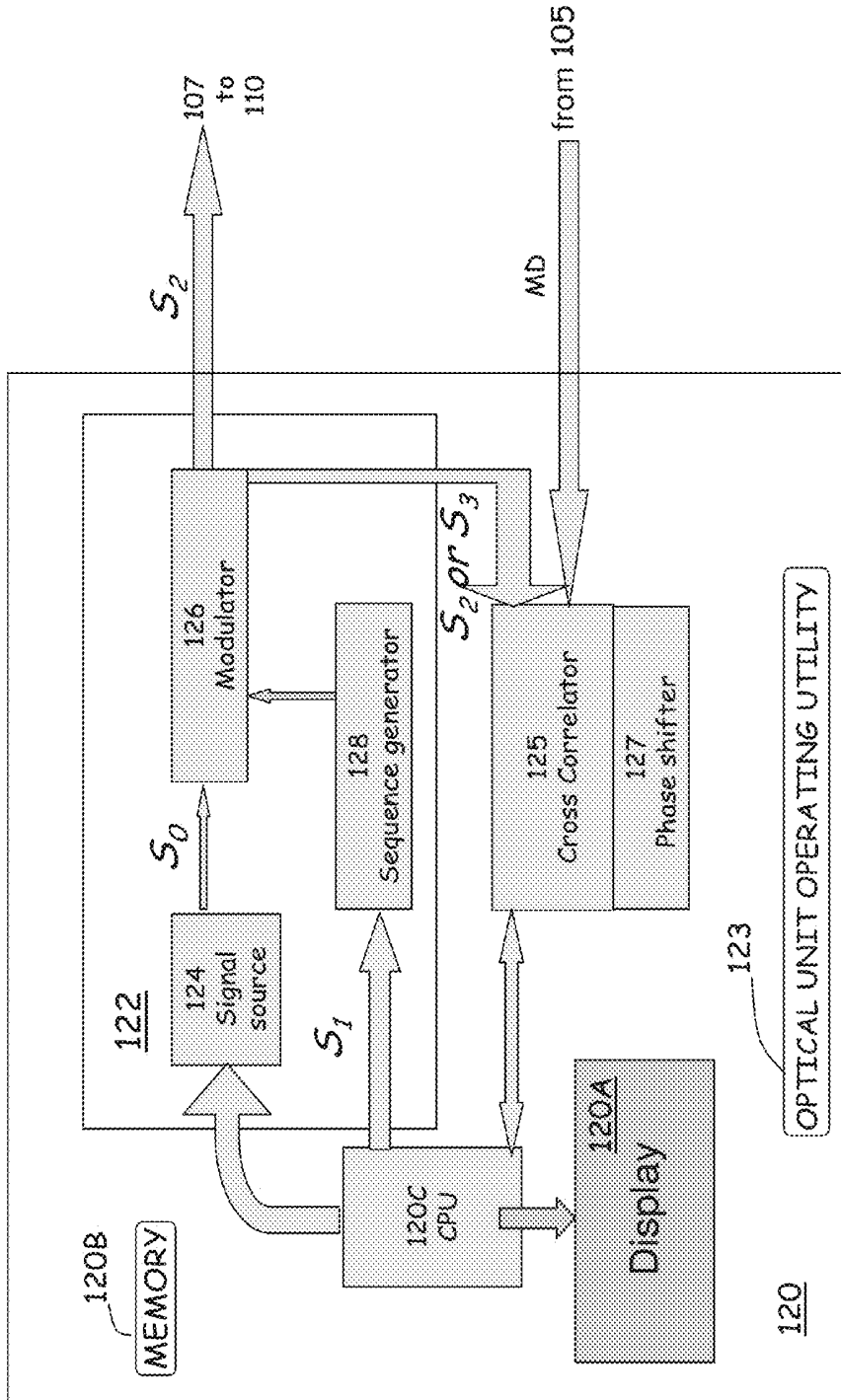
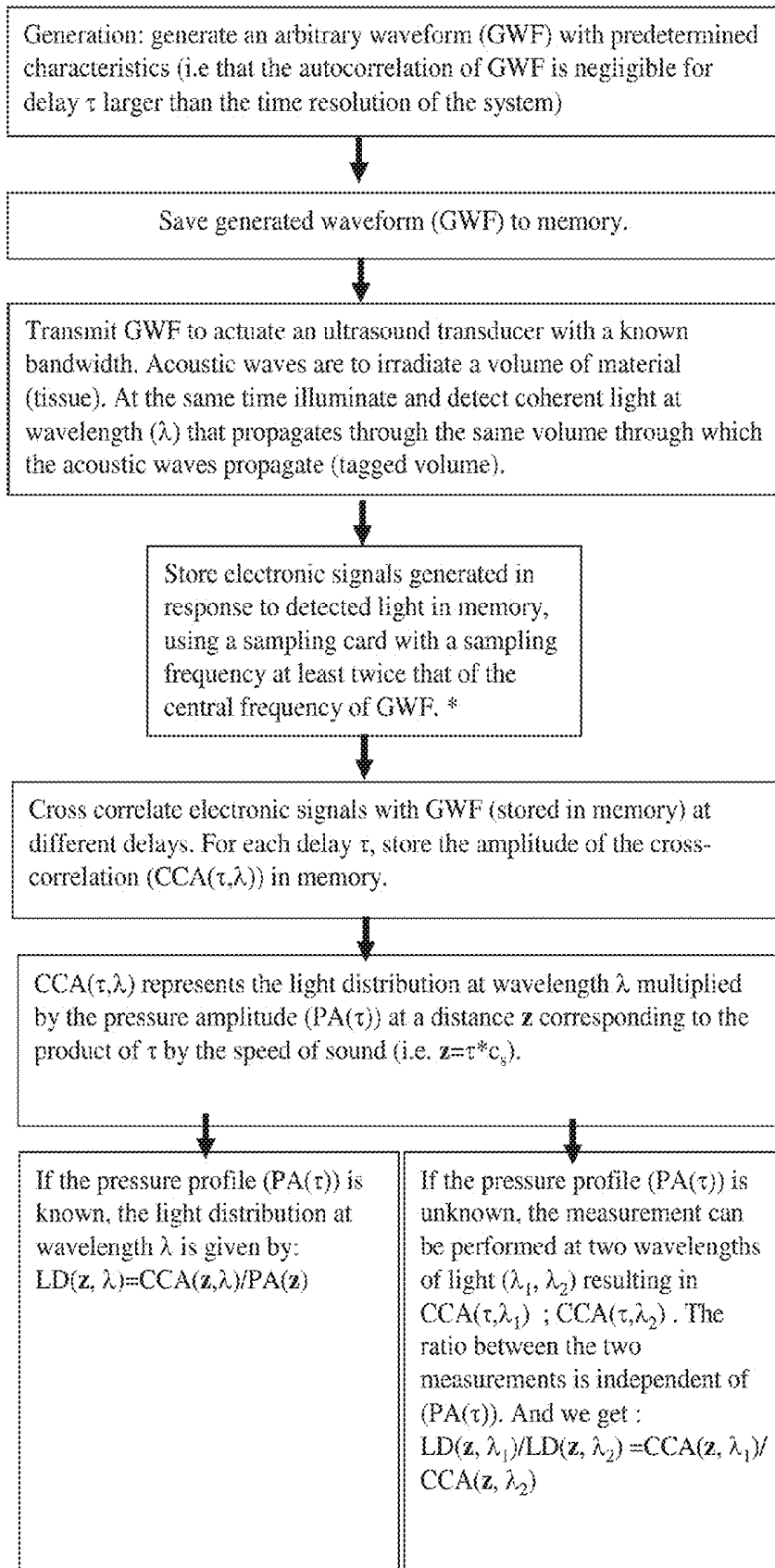

FIGURE 2A

FIGURE 2B



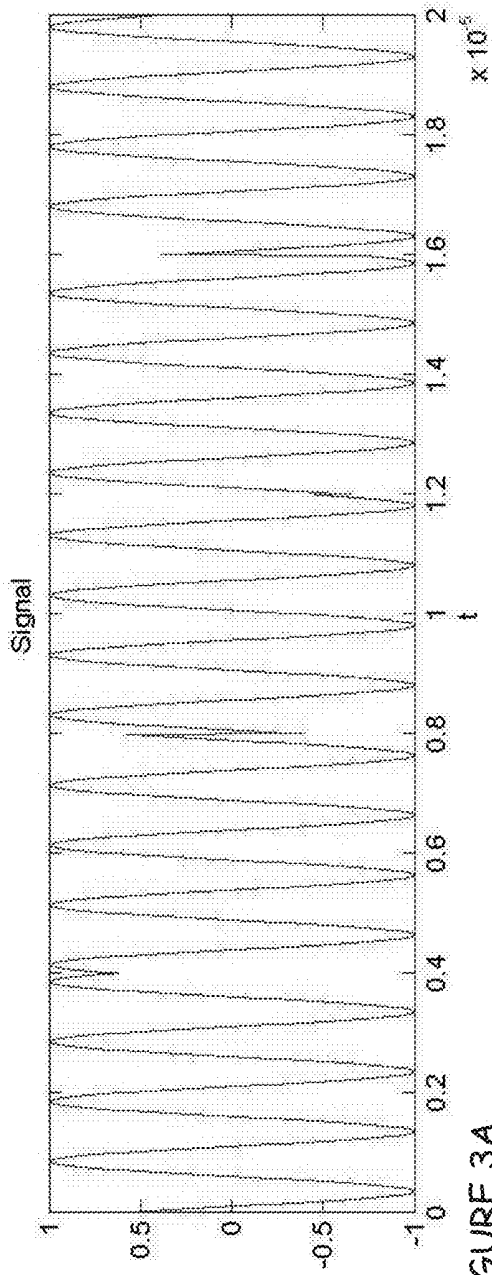

FIGURE 3A

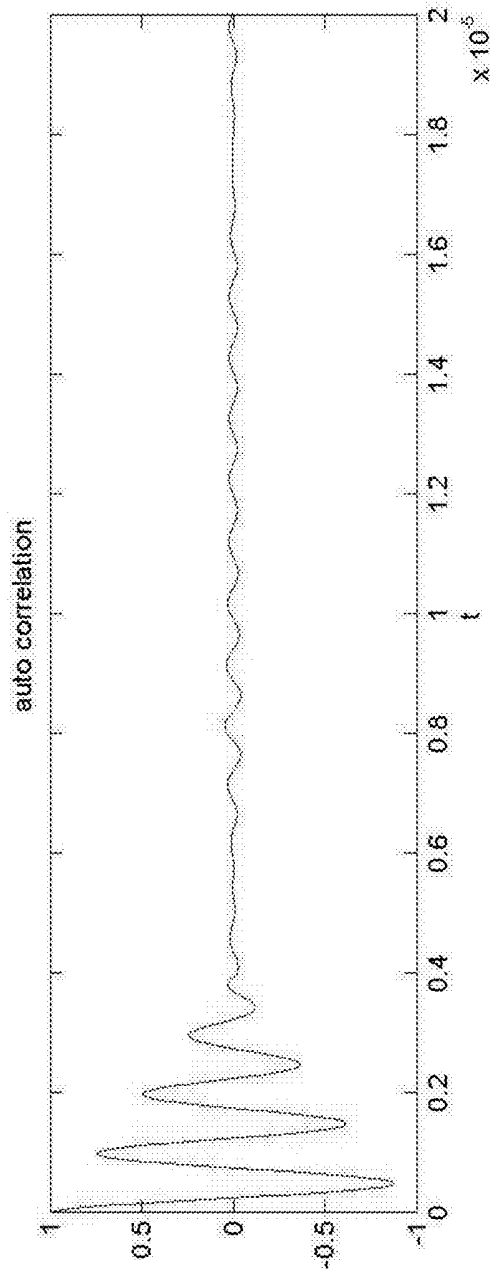

FIGURE 3B

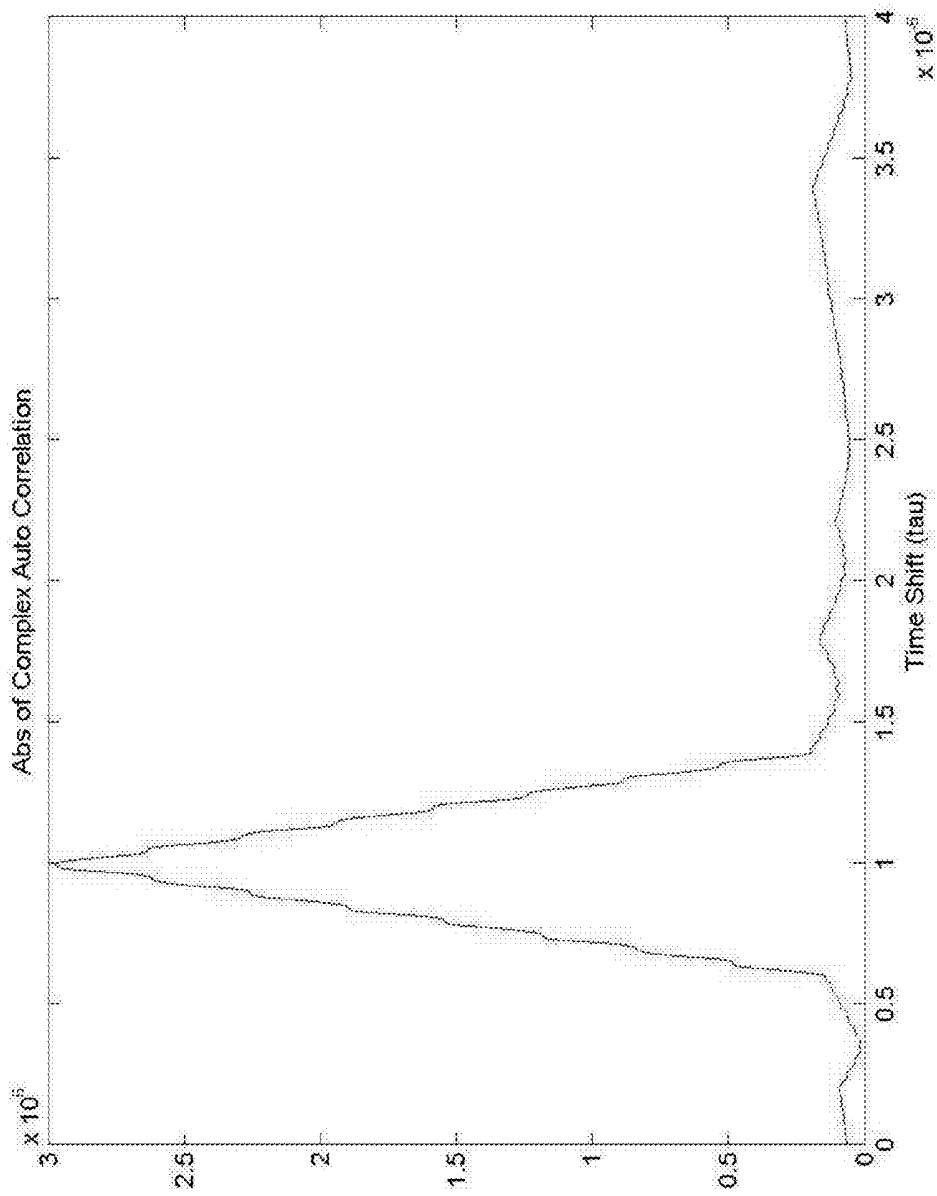

FIGURE 3C

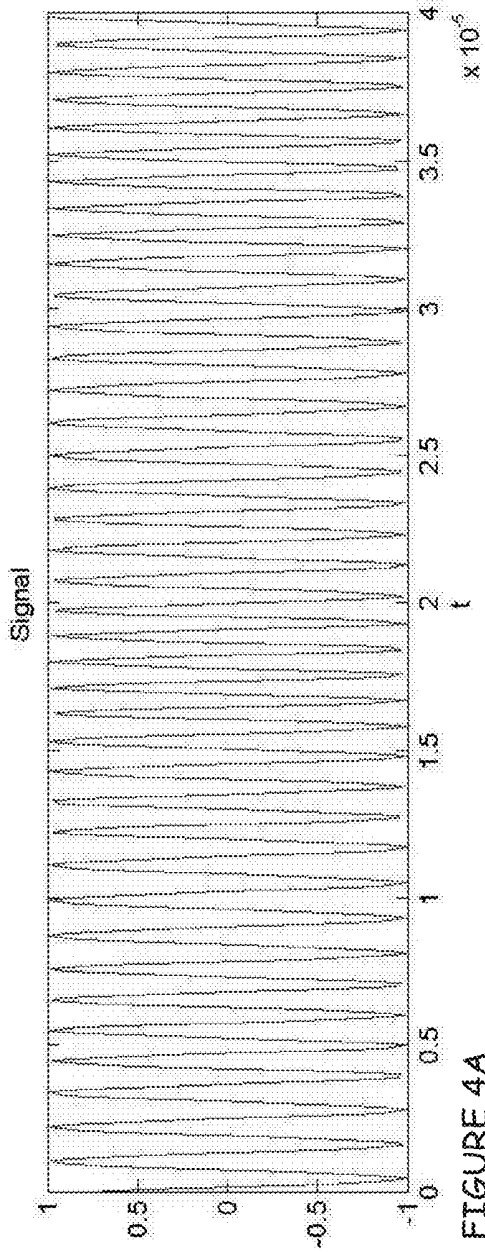

FIGURE 4A

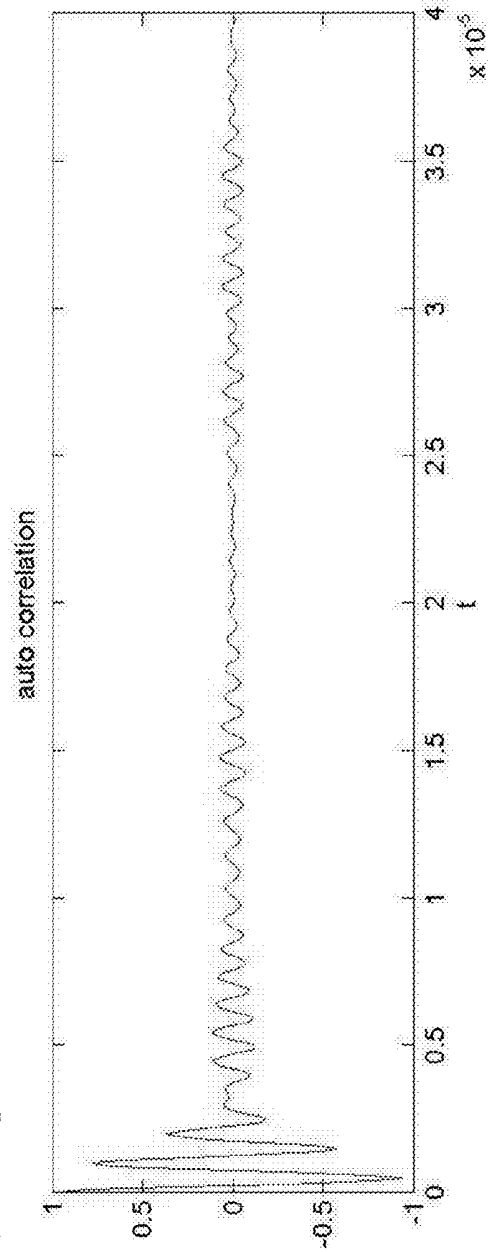

FIGURE 4B

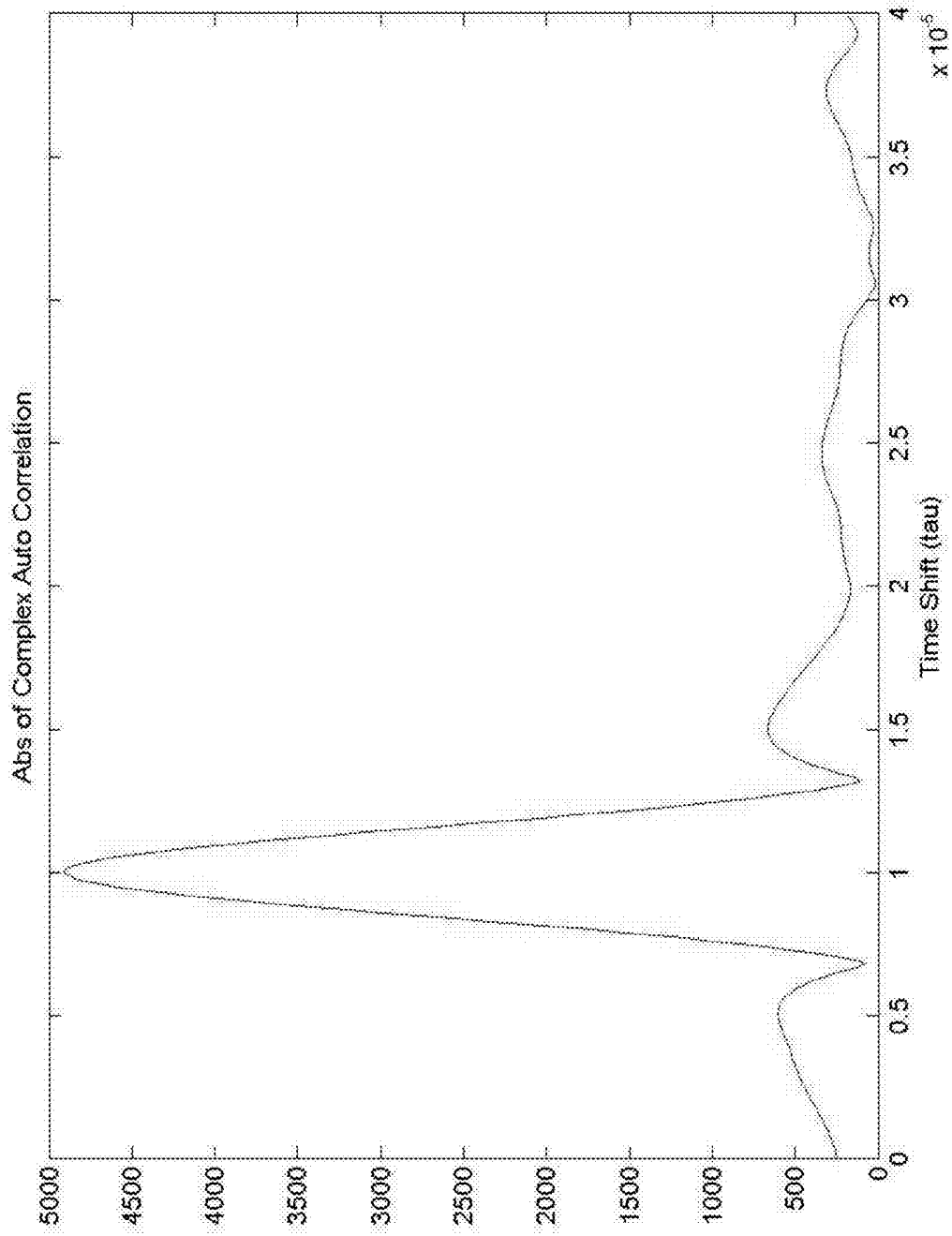

FIGURE 4C

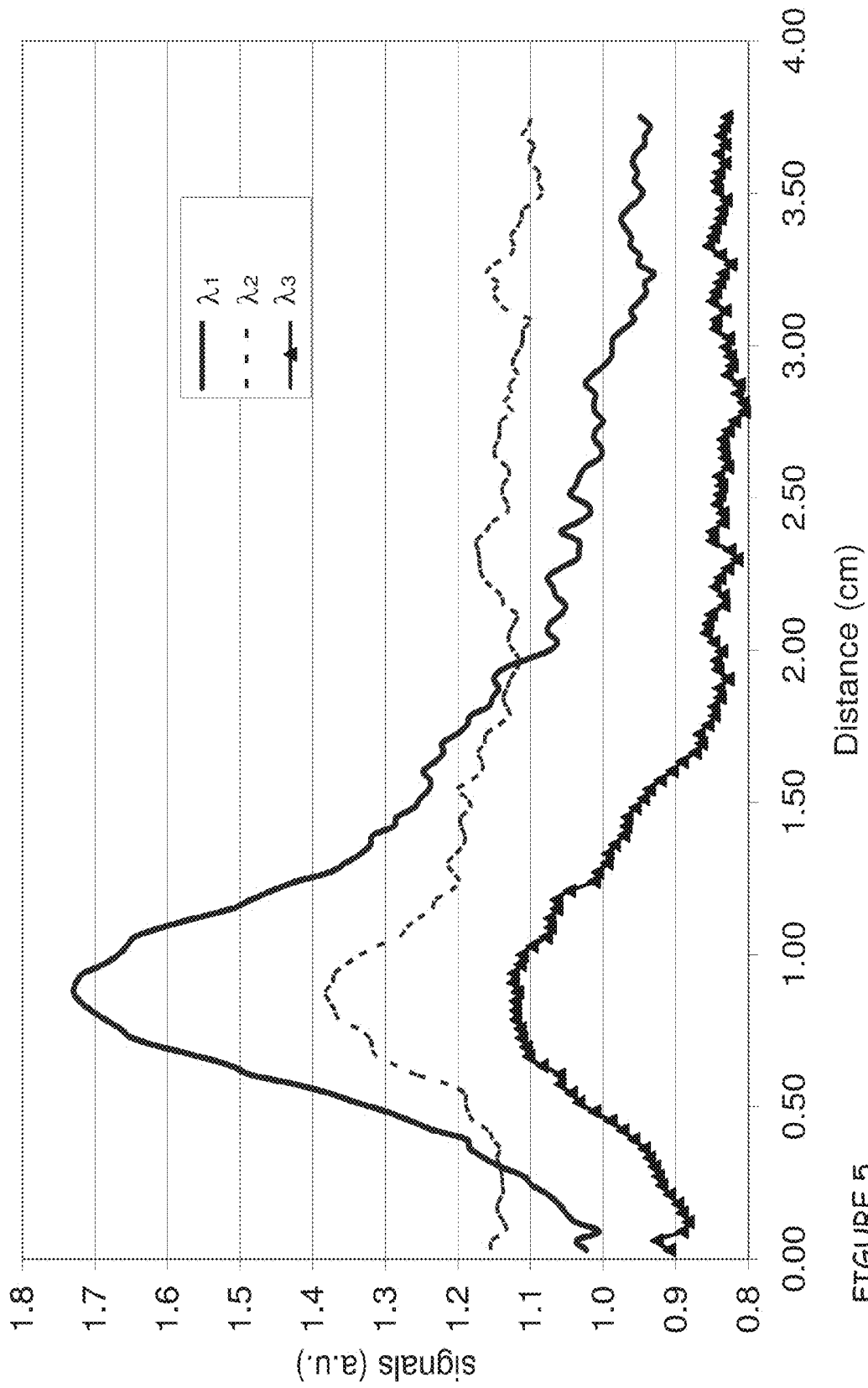

FIGURE 5

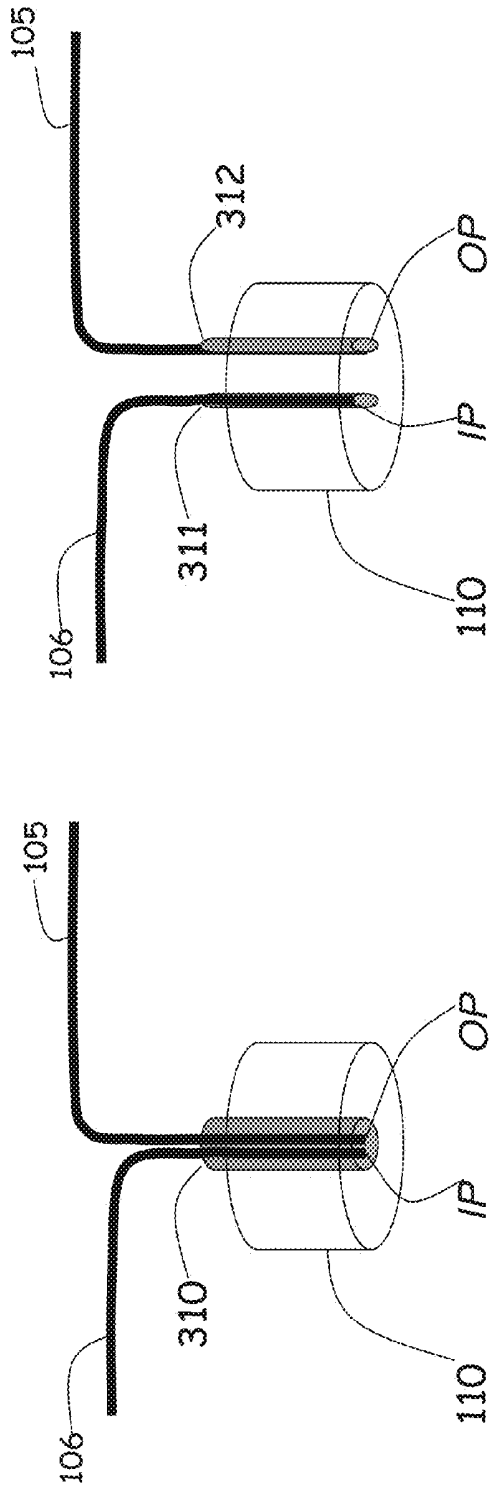

FIGURE 6A

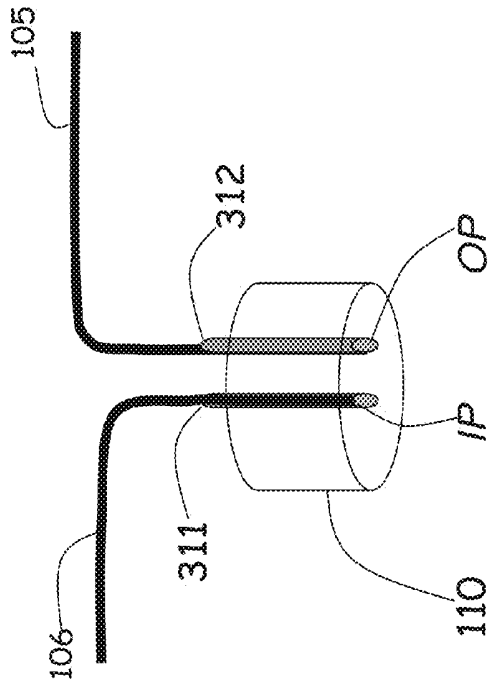

FIGURE 6B

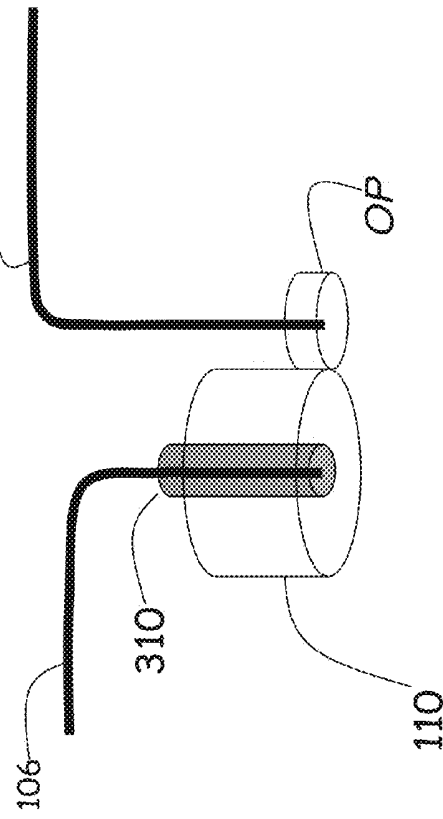

FIGURE 6C

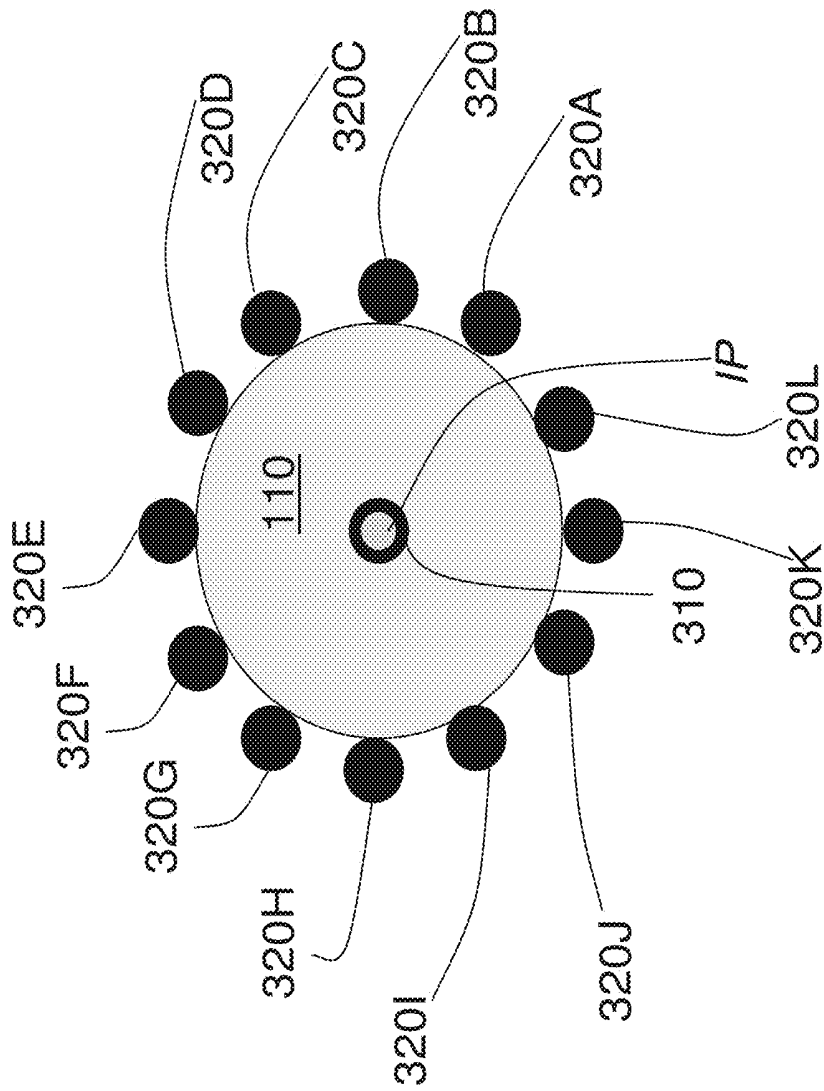

FIGURE 7A

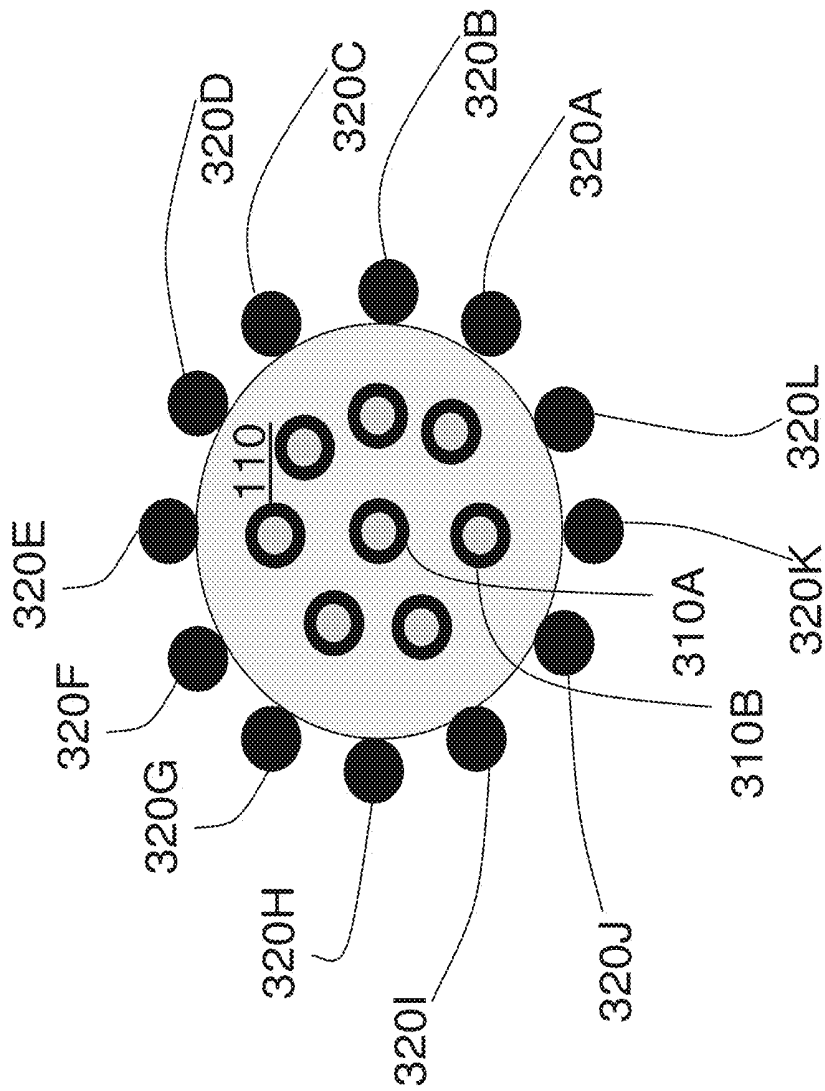

FIGURE 7B

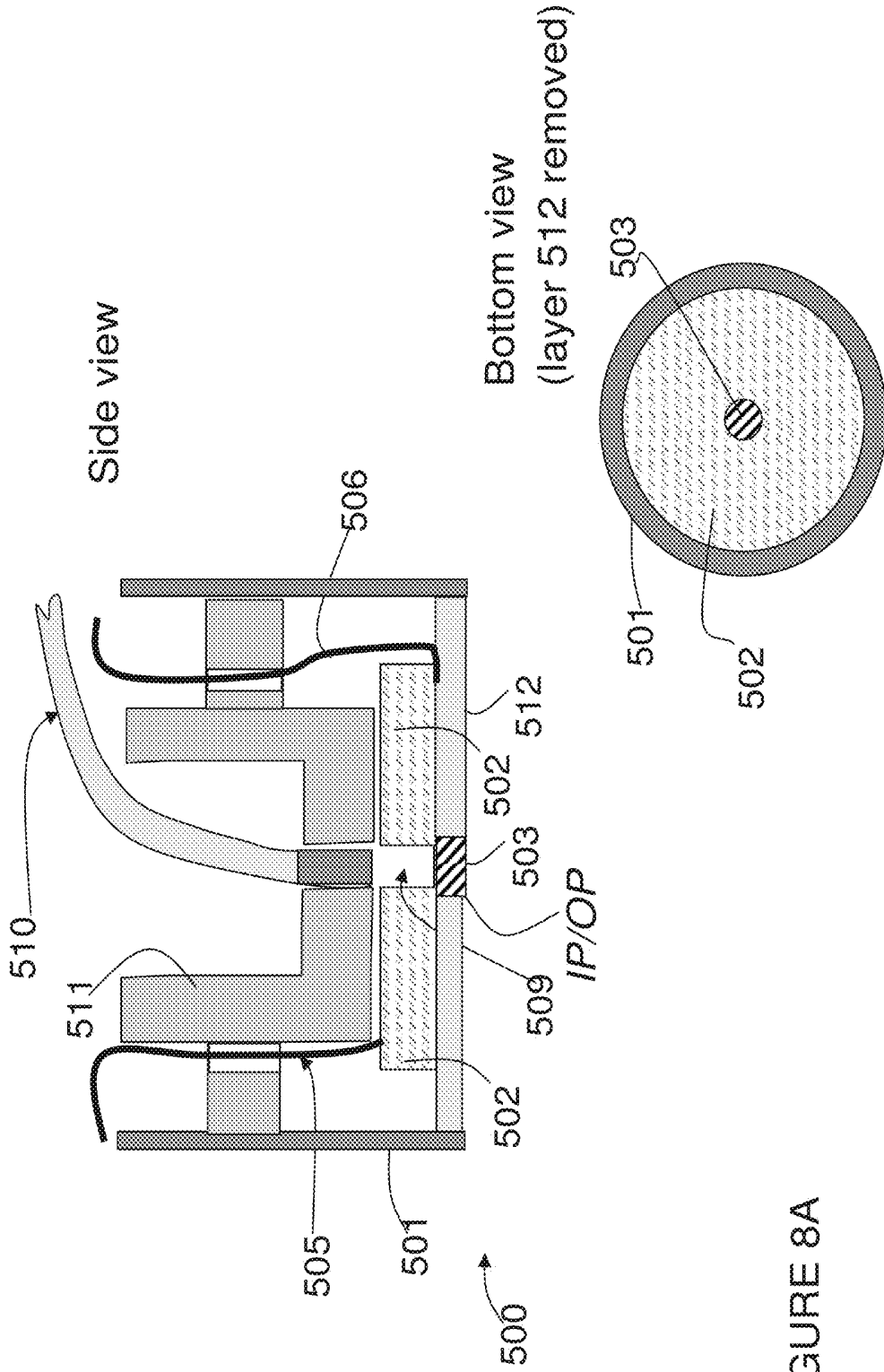
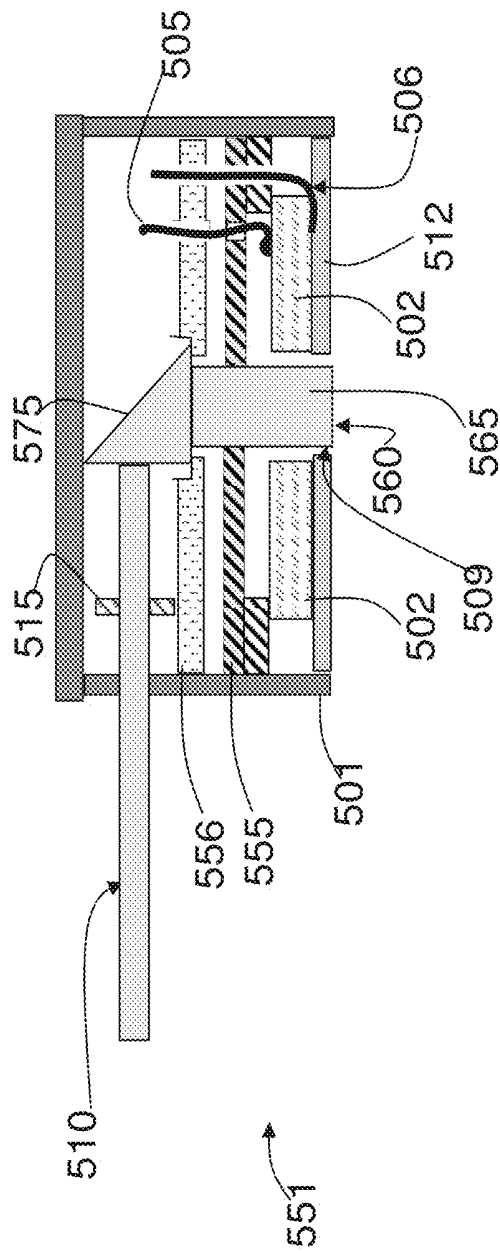

FIGURE 8A

FIGURE 8B



## SYSTEM AND METHOD FOR NONINVASIVELY MONITORING CONDITIONS OF A SUBJECT

### FIELD OF THE INVENTION

This invention relates to a method and system for monitoring a subject's condition, based on scattered light distribution through turbid media. The invention is particularly useful in medical applications.

### BACKGROUND OF THE INVENTION

Non invasive monitoring and imaging using non-ionizing radiation, allows medical professionals to diagnose and monitor a patient without invasive surgeries, or even without drawing blood. Pulse oximetry is one such revolutionizing technology, where non invasive monitoring of blood oxygenation using light has replaced blood gas analysis. Thus, pulse oximetry has become a gold standard monitor in every clinical setting, and has saved millions of lives.

During non-invasive monitoring, the concentration of certain chromophores (such as oxygenated and deoxygenated hemoglobin in oximetry) is calculated by detecting light that escapes the tissue, determining the optical properties of the tissue, and deriving therefrom the concentrations of the chromophores. Providing the tissue is homogenous, simple models allow for the calculation of these concentrations. However, as biological tissue is a complex scattering medium, measuring the local optical properties becomes a challenging task.

As light is highly scattered while propagating through turbid media such as biological tissue, photons that escape the tissue and reach a detector do not provide information about the path that they followed as they propagated through the medium. To acquire information about the optical properties of the tissue in the photons' path, several methods and algorithms have been developed. Such methods include frequency-domain spectroscopy, and photoacoustic spectroscopy [D M Hueber et al Phys. Med. Biol. 46 (2001) 41-62].

### SUMMARY OF THE INVENTION

The present invention utilizes the principles of ultrasound tagging of light. More specifically, the tagging of light by acoustic radiation is used to determine the optical response of a region of interest. The invention may be used, for example, to significantly improve oximetry and pulse oximetry based measurements.

According to the invention, a region of interest in a subject (e.g. human body) is illuminated with at least one wavelength of light, and is irradiated with acoustic radiation (preferably ultrasound) such that the acoustic radiation overlaps the illuminated region in at least a part of the region of interest during the duration of illumination and/or detection of the illuminating light (this overlapping volume is termed "tagged volume"). This acoustic radiation is termed acoustic tagging radiation. Light scattered from the subject's body and including photons that are tagged by the acoustic radiation and those that are not, is appropriately detected.

It is a common goal of any optical measurement technique to be capable of providing a high resolution measurement of the local light distribution with an improved signal to noise ratio (SNR). The present invention addresses this problem by providing a novel method and system based on the principles of acoustic tagging of light, where the acoustic radiation is

appropriately modulated (coded) to provide high-resolution and high-SNR measurement results.

The main idea of the present invention is based on the following understanding: The effect termed "Ultrasound Tagging of Light" (UTL) is based on the interaction of acoustic waves with the same tissue volume that is being probed by light. This interaction causes the light wave to be modulated, or tagged, with the characteristics of the acoustic wave (i.e. frequency, phase). As the propagation of acoustic waves in tissue is relatively slow (about 1500 m/sec in soft tissue), the location of the interaction of light with the acoustic radiation can be determined. The efficiency and power of the interaction of the acoustic waves with the medium affects the spatial and temporal resolution and the SNR of the measurement. There are three possible modalities for the generation of acoustic waves, a continuous wave (CW), a short burst of waves (SB), and a pulse. Operation with continuous waves produces a higher SNR. When a continuous acoustic wave (at a predetermined frequency range) interacts with light, and light is collected throughout the full propagation of the acoustic waves, a higher acoustic energy is available for the interaction, thereby increasing the signal. In addition, the spectral bandwidth of the continuous acoustic wave can be very narrow, thus reducing noise bandwidth. Thereby the SNR is greatly improved. However, the spatial resolution of a measurement produced with continuous acoustic waves is not as high as a measurement produced with short bursts or pulses of acoustic waves. This reduced spatial resolution is particularly limiting when the measurement geometry calls for propagation of acoustic waves essentially parallel to the direction of light propagation. As for the use of short bursts of waves and pulses, this provides better spatial resolution, but the acoustic energy of the interaction is lower and the bandwidth is wider as compared to those of a continuous wave mode, resulting in reduced SNR.

There is accordingly a need in the art for a measurement technique which can achieve both high spatial resolution and high SNR. The present invention solves this problem by utilizing generation of continuous acoustic waves (and therefore improving the SNR), where the continuous acoustic wave is a modulated (coded) signal characterized by a narrow autocorrelation function, thereby improving the spatial resolution.

The expression "narrow autocorrelation function" refers to autocorrelation which is negligible for any delay time larger than the determined time resolution of the system. The latter may for example be determined as the time resolution of detection of the electromagnetic radiation response, or as the temporal bandwidth of the acoustic excitation of the ultrasound transducer, or as the required spatial resolution divided by the speed of sound in the media.

In some embodiments of the invention, a pseudo random sequence, or specially designed sequences such as Barker codes, or Golay codes (used in radar technology) can be used. A combination of several such arbitrary signals (having different phases and/or amplitudes) can be used interchangeably. According to one specific but not limiting example, the modulated signal may be a non-periodic time function with predefined time intervals between such non-periodic occurrences.

In some embodiments of the present invention, the coding comprises a series of short pulses with high amplitude, that are separated by periods of low amplitude (or even zero amplitude). The duration of the high amplitude pulses depends on the required time resolution of the system. The separation duration between two consecutive pulses is determined such that the phase of light propagating through the media during the second pulse is independent of the phase of

light during the previous pulse of acoustic radiation. In addition, the consecutive high amplitude pulses may differ in frequency or may also be chirped.

The present invention thus provides for a 3D mapping of the light distribution in a turbid medium, obtaining a non-invasive means for collecting data about the structure and composition of the turbid medium. The use of a continuous acoustic signal utilizes the acoustic and light energy more efficiently, and lower acoustic and optical signals can be used while maintaining the desired SNR. Thus, the light levels and acoustic levels introduced into the subject are safer.

According to one broad aspect of the invention, a method is provided for use in determining one or more parameters of a subject's tissue, the method comprising:

(a) irradiating a region of interest of the subject with acoustic tagging radiation, the acoustic tagging radiation comprising at least one acoustic tagging beam being a coded continuous acoustic wave in the form of a predetermined function of at least one parameter of the acoustic radiation varying over time during a measurement time interval, said predetermined time function having a narrow autocorrelation;

(b) irradiating at least a portion of the region of interest with at least one electromagnetic beam of a predetermined frequency range;

(c) detecting an electromagnetic radiation response of said at least portion of the region of interest and generating data indicative thereof, said response comprising electromagnetic radiation tagged by the acoustic radiation, thereby enabling processing said data indicative of the detected electromagnetic radiation response, to determine at least one parameter of the subject's tissue in a region corresponding to the locations in the medium at which the electromagnetic radiation has been tagged by the acoustic radiation, and output data indicative of the at least one determined parameter.

According to another broad aspect of the invention, there is provided a system for use in determining one or more parameters of a subject, the system comprising:

an acoustic unit configured and operable for irradiating a region of interest with acoustic tagging radiation comprising at least one acoustic tagging beam being a coded continuous acoustic wave in the form of a predetermined function of at least one parameter of the acoustic radiation varying over time during a predetermined time interval used for measurements, said predetermined function having narrow autocorrelation; and

an optical unit configured and operable for irradiating at least a portion of the region of interest with at least one electromagnetic beam of a predetermined frequency range, detecting an electromagnetic radiation response of said at least portion of the region of interest and generating data indicative thereof, said response comprising electromagnetic radiation tagged by the acoustic radiation, said data being indicative of the at least one parameter of the subject in a region corresponding to the locations in the medium at which the electromagnetic radiation has been tagged by the acoustic radiation.

The generation of such a coded acoustic wave can be implemented as follows:

An arbitrary sequence can be produced and stored, the arbitrary sequence activating an arbitrary waveform generator. The latter (or an appropriate arbitrary switch) thus generates an arbitrary sequence of electronic signals which corresponds to the stored arbitrary sequence. Such an electronic signal in the form of an arbitrary sequence presents a modulating or coding signal for operating an acoustic transducer. The output of the acoustic transducer thus generated is a corresponding modulated acoustic wave. The arbitrary

sequence used for generation of a modulating signal can incorporate modulations of the original signal in frequency and/or phase and/or amplitude and/or any other parametric domain. The modulated signal should have a narrow autocorrelation that defines the time resolution of the detection. As indicated above, this may be a pseudo random sequence, or specially designed sequences (such as Barker codes, or Golay codes used in radar technology), or a combination of several such arbitrary signals having different phases and/or amplitudes used interchangeably.

The detection of the light response of the medium is implemented using one or more appropriate photodetectors, each for receiving light returned (scattered) from the medium and generating an electronic output corresponding to the detected light intensity. Light collected by the detector includes both tagged and untagged photons. The electronic output signal of the detector is processed by correlating it with the original modulated signal (stored arbitrary sequence).

According to some embodiments of the present invention, the correlation is done using a cross correlation function to determine the optical properties of the medium at different depths. To this end, the cross correlation is determined for different time delays from the onset of the acoustic wave. At each delay, the cross correlation represents the intensity of tagged light corresponding to a distance from the acoustic transducer (e.g. depth in the subject) equal to the product of the speed of sound in the subject's tissue and the delay time. Since the process of acoustic tagging of light does not have a constant phase relation with the acoustic tagging signal, a phase matching mechanism is preferably added to the cross correlating algorithm. The amplitude of the cross correlation at each delay is assumed to correspond to a function of the light distribution at the corresponding depth and the pressure amplitude of the acoustic wave at that depth. For example, this function corresponds to the product of the two parameters. The light distribution can be determined by eliminating the contribution of the acoustic wave distribution to the amplitude of the cross correlation. By fitting the light distribution to an expected distribution (for example, an exponential attenuation), the optical properties of the layer where the amplitude of the cross correlation is measured are determined.

In some embodiments of the present invention, multiple light sources and/or detectors and/or acoustic sources may be used. Such configurations improve the spatial resolution of the measurements and enable the mapping of a larger volume of the medium. For the purposes of the present invention, when multiple acoustic sources (i.e. multiple acoustic waves) are used, all acoustic sources can use either different frequency ranges or the same frequency range, as long as the modulating sequences of the different acoustic sources have zero or near zero cross correlation. When the electromagnetic response signal is detected and decoded, each acoustic beam tagging effect can be estimated separately by correlating the respective received signal with the original modulating sequence for this acoustic source. The contribution of other acoustic sources to such a correlation is negligible given the zero or near zero cross correlation between the sequences, as will be described below.

When multiple acoustic sources are used, they may be arranged and operated such that acoustic radiations produced by these sources interfere in at least a volume part of the region of interest. By this, the acoustic power in that volume can be enhanced or nullified according to the desired application. In this case, the different acoustic signals generated by different acoustic sources are selected such as to provide non-zero cross correlation thereof at a predetermined delay.

Thus, in the region of interest, the overall acoustic radiation is a combination of several acoustic signals.

The present invention can be used for various applications, including medical and non-medical ones. Considering the medical applications, the present invention can be used for example for determining oxygen saturation in blood and/or tissue, as well as determining concentration of substance(s) in blood and/or tissue such as hemoglobin, glucose, etc. As an example, the invention is used in the determination of oxygen saturation of the tissue layers, and is therefore described below with respect to this specific application, but it should be understood that the invention is not limited to this specific application.

#### BRIEF DESCRIPTION OF THE DRAWINGS

In order to understand the invention and to see how it may be carried out in to practice, a preferred embodiment will now be described, by way of non-limiting example only, with reference to the accompanying drawings, in which:

FIG. 1 is a schematic illustration of a measurement system according to an embodiment of the present invention;

FIG. 2A is a block diagram of an example of a control unit for use in the system of the present invention;

FIG. 2B is a flow chart of an example of a method of the present invention;

FIGS. 3A to 3C exemplify generation of a phase coded continuous acoustic signal, where FIG. 3A shows a segment of an exemplary signal, FIG. 3B shows auto correlation of said signal, and FIG. 3C shows the correlation  $C(\tau_0)$  for time delay  $\tau_0=10^{-5}$  seconds;

FIGS. 4A to 4C similarly show an example of generation of a frequency coded continuous acoustic signal;

FIG. 5 shows an example of the cross correlation of a synthetic tissue model using phase modulated continuous acoustic signal for three different light wavelengths;

FIGS. 6A-6C and 7A-7B show examples of different configurations of a probe device according to the invention; and

FIGS. 8A and 8B show an example of transducer's assemblies including light guides.

#### DETAILED DESCRIPTION OF EXEMPLARY EMBODIMENTS

Reference is made to FIG. 1 illustrating schematically a specific but not limiting example of a measurement system, generally designated **100**, configured and operable according to the invention for non-invasive determination of one or more parameters (properties of tissue components) of a subject, particularly a human or animal body. The parameter(s) to be determined may include oxygen saturation level, or values/levels of various other parameters such as the concentration of an analyte in the patient's blood, or the perfusion of an analyte/metabolite in tissues. The values of these parameters are derived from the light distribution in a region of interest **200** as will be described below.

System **100** includes such main constructional parts as a measurement unit **101** and a control unit **120**. Measurement unit **101** includes an optical or electromagnetic unit (module) **101C** and an acoustic unit (module) **110**. Optical module **101C** includes an illumination assembly **101A** and a light detection assembly **102A**, and acoustic module **110** is configured as an acoustic transducer arrangement including one or more acoustic transducers. Control unit **120** is configured to control the operation of measurement unit **101**, and to

process, analyze measured data generated by measurement unit **101** (its detection assembly), and display the results of the analysis.

Illumination assembly **101A** includes one or more illumination sources associated with one or more different locations with respect to the region of interest. Similarly, detection assembly **102A** includes one or more detector units associated with one or more different detecting locations. It should be noted that the illumination source includes one or more lighting elements each formed, for example, by a light emitter and possibly also a light guiding unit (e.g., an optical fiber or fiber bundle). For example, a probe part of the measurement unit by which it is to be brought to the body part under measurements may carry the light emitter itself, or may carry a distal end of a light guiding unit which by its opposite end is connected to an external light emitter. The detector unit includes one or more light detecting elements each formed by a light sensor and possibly also a light guiding unit (e.g., optical fiber or fiber bundle); the probe part by which the measurement unit is to be brought to the body part may carry the light sensor or a distal end of the light guide which by its opposite end is coupled to an external light sensor.

The lighting element(s) and/or detecting element(s) may be incorporated within the acoustic transducer arrangement as will be described further below with reference to FIGS. 6A-6C and 7A-7B. The lighting element(s) and detecting element(s) may be incorporated in one unit and the acoustic transducer arrangement placed to the side of (and not in between) the detector element(s) and the lighting element(s).

In the example of FIG. 1, illumination assembly **101A** includes a single illumination unit, and light detection assembly **102A** includes a single detector unit. It should be understood that this does not necessarily signify the use of a single lighting element and/or a single detecting element. Such a single illumination unit, as well as a single detection unit, may include an array of lighting elements and an array of detecting elements, such that all the lighting elements of the same illumination unit are to associated with the same location with respect to the region of interest, and similarly all the detecting elements of the same detection unit are associated with the same location relative to the region of interest. In some other embodiments of the invention, the illumination assembly includes more than one illumination unit and/or more than one detection unit, as will be described below.

Optical module **101C** and acoustic module **110** are connected to control unit **120**, e.g., by cables **105**, **106** and **107** as shown in FIG. 1, or using wireless signal transmission (e.g. IR, RF or acoustic signal transmission) as the case may be.

Control unit **120** is typically a computerized system including inter alia a power supply unit (not shown); a control panel with input/output functions (not shown); a data presentation utility (e.g. display) **120A**; a memory utility **120B**; and a data processing and analyzing utility (e.g. CPU) **120C**. Also provided in control unit **120** are a signal generator utility **122** (e.g. function generator and phase control) configured and operable to control the operation of acoustic unit (transducer arrangement) **110**, and an appropriate utility **123** configured for operating optical unit **101C**. Data processing and analyzing utility **120C** is preprogrammed for receiving measured data (MD) coming from detection assembly **102A** (via cable **105** in the present example) and for processing this measured data to identify the detected light distribution corresponding to measurements locations in the region of interest, thereby enabling determination of one or more desired parameters of the region of interest, e.g., oxygen saturation level. Also provided in the control unit is a correlator utility **125** (typically a software utility) associated with the signal generator **122**.

According to this example, measurement unit **101** is configured as a probe having a support structure (preferably flexible) **403** to be put in contact with the body part to be measured. Support structure **403** carries at least part of illumination assembly **101A** and at least part of detection assembly **102A**. As shown in the figure, provided on the probe are: a light output port OP (constituting a lighting element) associated with the illumination source, a light input port IP (constituting a detecting element) associated with the detector unit, and an acoustic port **245** associated with the acoustic unit. It should be understood that light output port OP may be integral with the light emitting element(s) or may be constituted by the distal end of an optical fiber unit connected at its other end to one or more light emitting element(s) located outside the support structure (e.g., at the control unit). Similarly, light input port IP may be integral to with the light detecting element(s) or may be constituted by the distal end of an optical fiber unit which by its other end is connected to one or more detecting elements (light sensors) located outside the support structure (e.g., at the control unit).

Generally, illumination assembly **101A** can be configured to produce light of at least one wavelength. According to an embodiment of the present invention, the illumination assembly generates light of multiple (at least two) different wavelengths. Illumination assembly **101A** may for example be preprogrammed to produce the different wavelength components at different times, or to simultaneously produce wavelength components with different frequency- and/or phase-modulation. Accordingly, control unit **120** is preprogrammed to identify, in a signal generated by detection assembly **102A**, the corresponding wavelength of light, using time, and/or phase, and/or frequency analysis. The detection assembly may include an appropriate frequency filter.

Thus, illumination assembly **101A** may include the light emitter(s) carried by support structure **403** and communicating with control unit **120** (using cables **106** or wireless signal transmission). Alternatively, the light emitter(s) may be located outside support structure **403** (e.g., within control unit **120**) and connection **106** is constituted by a light guiding assembly (e.g., optical fibers) for guiding light to light output port OP located on support structure **403**. Detection assembly **102A** includes one or more light detectors such as a photomultiplier tube, photodiode or an avalanche photodiode. The light detector may include an image pixel array, e.g., CCD or other array of photodiodes. The detector(s) may be accommodated outside support structure (probe) **403**, e.g., may be located within control unit **120**, and returned light (light response) may be guided from input port IP of the detection assembly via light guiding means **105** (e.g., optical fibers). Alternatively, the detector(s) may be located at the support structure and connection **105** is configured to connect an electrical output of the detector(s) indicative of measured data MD to control unit **120**. As indicated above, detection assembly **102A** may include two separate detectors or an array of detectors. It should also be understood that connections **105** and **106** may be electric wires connecting control unit **120** to the illumination assembly and detection assembly located on support structure, **403**, or the connection may be wireless.

Thus, generally, the terms "illumination assembly" and "detection assembly" as carried by a support structure (probe) which is brought to a body part to be measured, are constituted by at least light transmitting and receiving ports. Similarly, transducer arrangement **110** may be located on support structure **403** (so as to be brought in acoustic contact with the skin), and connected to control unit **120** (its signal generator **122** and CPU **120C**) using cables and/or optical fibers **107** and/or using wireless means. Alternatively, connection **107**

may constitute an acoustic guiding unit for connecting the transducer(s) located outside the support structure (e.g., at the control unit) to acoustic output port **245** on the support structure.

Transducer arrangement **110** may be a single acoustic element, configured and operable for emitting focused or unfocused acoustic beams or for emitting acoustic pulses; or a piezoelectric phased array capable of producing acoustic beams with variable direction, focus, duration and phase; or may be an array of silicon units or other pressure generating units configured as a single element or an array of elements (phased array); or a complete ultrasound imaging probe comprising transmitting and receiving units. The transducer arrangement may be connected to an amplifier (not shown), e.g. located within control unit **120**, operable to amplify electronic signals generated by signal generator **122**. The control unit is preprogrammed to operate transducer arrangement **110** (via signal generator **122**) in a predetermined manner to produce a coded acoustic continuous wave, which is a predetermined function of at least one parameter of the acoustic radiation varying over time during a measurement time interval. This predetermined function is selected to have a narrow autocorrelation function (i.e. an autocorrelation which is negligible for any delay time larger than the determined time resolution of the system, for example, determined as the time resolution of detection of the electromagnetic radiation response, or as the temporal bandwidth of the ultrasound transducer, or as the required spatial resolution divided by the speed of sound in the media), as will be described more specifically below.

Detection assembly **102A** generates electronic signals in response to the amplitude and phase of light collected at input port IP. These electronic signals may be filtered by analog and/or digital filters, for example bandpass filters, that are appropriately provided being connected to data processing utility **120C** of control unit **120** or being a part of this processing utility.

Reference is now made to FIG. **2A** showing more specifically an example of the functional elements and operation of control unit **120**. As shown, signal generator **122** includes a signal source **124**, a modulator **126** and a sequence generator **128**. Also, in the present example, the control unit includes a phase shifter utility **127**, as in the present example phase is a modulatable parameter in a continuous acoustic wave to be generated by the acoustic unit. However, the invention is not limited to this specific example, and the control unit may include a frequency and/or amplitude shifter utility, alternatively or additionally to the phase shifter. CPU **120C** controls the operation of signal generator **122** and cross correlator **125**, and receives signals from cross correlator **125**. CPU **120C** also controls signal source **124** and sequence generator **128**. Signal source **124** generates a base signal  $S_0$  (e.g. a sine wave of a certain frequency, or a chirped signal, or a train of square waves at a central frequency). Signal  $S_0$  passes through modulator **126** that controls one or more of its parameters (e.g. at least one of the following: phase, frequency, frequency gradient (chirp), phase jump, amplitude, duty cycle, chirp gradient) to produce a modulating (or coding) signal  $S_2$  to operate the acoustic transducer to produce an acoustic (ultrasound) sequence. Alternatively modulating signal  $S_2$  comprises a combination of such sequences. The operation of modulator **126** is controlled by sequence generator **128**. CPU **120C** transmits a signal  $S_1$  to sequence generator **128**, that controls its operation. Sequence generator **128** in turn controls the operation of modulator **126** according to this signal  $S_1$ . Modulating signal  $S_2$  that exits modulator **126** is a result of the combination of base signal  $S_0$  with the modulation induced by

modulator **128** on this signal. This signal  $S_2$  is transmitted to transducer arrangement **110** via connection **107**. An additional power amplifier can be used to amplify signal  $S_2$  before actuating the transducer. Signal  $S_2$  is also transmitted to cross correlator **125**, which correlates this signal  $S_2$  with measured data MD coming from detection unit **102A** through connection **105**. Alternatively, cross correlator **125** may correlate a signal  $S_3$  corresponding to signal  $S_2$  with the measured data. Corresponding signal  $S_3$  is for example the amplitude of signal  $S_2$  or its absolute value, or another function corresponding to signal  $S_2$ . Phase shifter **127** controls the phase of signal  $S_3$ , such that a phase shift is generated between signal  $S_2$  and signal  $S_3$ . The output of cross correlator **125** (e.g. the amplitude or phase of the cross correlation at different delays) is processed by CPU **120C** and displayed on display **120A**.

Reference is made to FIG. **2B** exemplifying a method of the present invention suitable to be used to extract the light distribution in the tissue. An arbitrary waveform (GWF) is generated with predetermined characteristics such that the auto-correlation of to GWF is negligible for any delay  $z$  larger than the time resolution of the system. This waveform GWF is saved to memory. This arbitrary waveform corresponds to the above-described modulating signal  $S_2$ .

The GWF is transmitted to actuate an ultrasound transducer (**110** in FIG. **1**) with a known bandwidth, for producing acoustic waves in the form of a non-periodic sequence to irradiate a volume of medium (tissue), at least part of a region of interest (**200** in FIG. **1**). Concurrently, the illumination assembly is operated to illuminate the medium with coherent light of a certain wavelength  $\lambda$ . This light propagates through the same volume through which the acoustic waves propagate (tagged volume), and light returned from the medium is detected (representing a light response of the medium).

Electronic signals generated by the detection assembly in response to the detected light are stored in memory, using a sampling card with a sampling frequency, which is at least twice the transducer's bandwidth, thereby enabling exact reconstruction of a continuous-time signal from its samples. These signals are cross correlated against the GWF electronic signals, or against a function of the GWF signal as described below, stored in memory with different time delays as applied. For each delay  $\tau$ , the amplitude of the cross-correlation ( $CCA(\tau, \lambda)$ ) is stored in memory. According to a preferred embodiment of the present invention,  $CCA(\tau, \lambda)$  represents the light distribution at wavelength  $\lambda$  multiplied by the acoustic power distribution or pressure amplitude, or a function of the acoustic pressure amplitude ( $PA(\tau)$ ) at a distance  $z$  corresponding to the product of  $\tau$  and the speed of sound  $c_s$  in the measured tissue (i.e.  $z = \tau \cdot c_s$ ).

Pressure profile ( $PA(\tau)$ ) may or may not be known. In the case where the overall output light distribution function is a product of the pressure profile and the light distribution function within the medium, if the pressure profile is known, the light distribution LD at wavelength  $\lambda$  is determined as

$$LD(z, \lambda) = CCA(z, \lambda) PA(z) \quad [1]$$

In case the ( $PA(\tau)$ ) is unknown, the measurements are performed using at least two different wavelengths  $\lambda_1, \lambda_2$  of light providing two corresponding cross-correlation amplitudes  $CCA(z, \lambda_1)$  and  $CCA(z, \lambda_2)$  respectively. A ratio between the two measurements is independent of ( $PA(\tau)$ ), thus providing the ratio between the light distributions determined as

$$\frac{LD(z, \lambda_1)}{LD(z, \lambda_2)} = \frac{CCA(z, \lambda_1)}{CCA(z, \lambda_2)} \quad [2]$$

This will be described more specifically further below.

An example of an acoustic sequence used in an embodiment of this invention utilizes a random number generator with a long enough period (infinite relative to the used segment). An example of such a function might be:

$$S_2 = A_1 \cos(\omega t + \Theta(i)) \quad [3]$$

where  $A_1$  is the amplitude,  $i = \text{floor}(t/\tau)$  and  $\Theta$  is a sequence of random numbers in the range  $[0, 2\pi]$  generated by any rectangular pseudo random generator.

In this example, the phase of signal  $S_2$  of angular frequency  $\omega$  (produced by modulator **126** in FIG. **2A**) is randomly shifted for each segment of duration  $\tau$ . Here,  $\tau$  determines the width of the auto correlation of the signal around zero, and hence the spatial resolution of the processed signal. The lowest limit of a range of values of  $\tau$  may be bound by the bandwidth of the acoustic system, which is proportional to  $1/\tau$ .

FIGS. **3A** and **3B** show, respectively, a segment of typical signal  $S_2$  and its auto correlation. The tagging of incident light is detected as a result of interaction between acoustic waves and photons whose optical path and consequently phase is modulated by motion of scattering particles in the tissue. The phase of the received signal (corresponding to the tagged photons) relative to the phase of transmitted signal  $S_2$  varies with time and depth and is also unknown.

Hence, processing of the measured data indicative of the detected light response includes processing of the correlated signal to search for the phase shift that gives the best correlation for each delay. This can be done by correlating the measured data with a complex phasor representation of the acoustic sequence and taking the absolute value of the resulting phasor. Considering the above example for signal  $S_2$ , the complex phasor is  $S_p = e^{i(\omega t + \Theta(i))}$  and the correlation  $C(\tau)$  is to be calculated as

$$C(\tau) = \sum_t D(t) S_p(t - \tau) \quad [4]$$

where  $D$  is the measured data (MD in FIG. **1**);  $S_p$  is an example for signals  $S_3$  that can be used to determine the correlation between  $S_2$  and the measured data.

If the signal originates from a known delay  $\tau_0$  with arbitrary phase shift  $\phi$ , the result would be:

$$C(\tau_0) = \left| \sum_t \cos(\omega t + \Theta(i) + \phi) S_p(t - \tau_0) \right| \quad [5]$$

FIG. **3C** illustrates the output  $C(\tau_0)$  for  $\tau_0 = 10^{-5}$  seconds and any value of  $\phi$ .

A measurement interval, i.e. the duration of signal  $S_2$  in one measurement epoch, should preferably be as long as possible to enhance the signal to noise ratio (SNR) of the system. This can be implemented under the assumption that a scattering pattern is constant during the measurement, and therefore a phase relation of the measured data and the original signal  $S_2$  is constant (even if such a relation is unknown). The temperature related Brownian motion of the scattering particles and other effects in a live tissue, such as motion of blood cells,

enforce a practical upper limit for the measurement duration. These motions cause the interference pattern between the different photons on the sensing surface of a detector (called “speckle pattern”) to be time varying, and cause the phase relation between the measured data and signal  $S_2$  to vary with time. The measurement interval is therefore bounded by the speckle correlation time, defined, for example, as disclosed in Lev et al. in J. Opt. Soc. Am. A Vol. 20, No. 12 (December 2003).

Signal  $S_2$  may comprise a sequence of short pulses, that are separated by periods of low (or even zero) amplitude. The separation period between pulses is determined as the time period where the phase of light that propagates through the media during the second pulse is independent of the phase of light that propagates through the media during the first pulse. Preferably, the separation time should be longer than the speckle correlation time. As the speckle correlation time depends on the properties of the media (such as its temperature), the signal  $S_2$  can be determined according to the properties of the media being monitored. By another option, a plurality of separation durations can be used, and an optimal separation duration (providing optimal SNR or an optimized signal parameter) should be selected for measurement. According to yet another option, the optimal separation itself may be monitored, to provide a measure for a property of the media (such as its temperature or the flow of blood through the tissue).

In some cases, the above pulses can be replaced each by a set of multiple pulses that are transmitted over the same phase of light—thus to allow obtaining strong enough signal by means of averaging. The separation durations between these inner-set of pulses is selected to be large enough so that during the propagation of a single pulse (including echoes) through the region of interest the pulses do not co-exist inside the region of interest, and to be smaller than the speckle correlation time.

If longer integration is required to further improve the SNR, averaging can be carried out between separate measurements’ intervals, but this averaging is done after the absolute value of the complex correlation is calculated separately for each of the measurements. In the case where  $S_2$  comprises a series of pulses, the averaging may be performed over the absolute value of the cross correlation for each pulse separately. For example, averaging can be performed over a predetermined number of measurements that are separated by a predetermined time delay. This averaging might be advantageous in cases where the measured data is periodic (i.e. changes periodically as a function of time as in the case of modulation of the blood volume). For example, averaging over different portions of measured data can be correlated with the peaks/troughs of the blood volume during systolic/diastolic periods in a pulsating blood volume, having a predetermined delay from each other. In this case, a difference between the signals corresponds to the oxygen saturation levels of blood (as in the case of pulse oximetry).

Signal  $S_2$  can for example include a plurality of different arbitrary signals. These may for example be different signals having different amplitudes and/or different frequencies and/or different phase variations.

The above example demonstrates random modulation of the phase of signal  $S_2$ . As indicated above, other parameters of signal  $S_2$  may be modulated according to a predetermined function.

The following is an example related to a frequency modulation of signal  $S_2$ . Signal  $S_2$  can be expressed by

$$S_2 = \cos(\phi(t)), \quad [6]$$

where  $\phi$  is selected so that

$$\frac{d\phi}{dt} = \omega_i,$$

and where  $i = \text{floor}(t/\tau)$  and  $\omega$  is a random sequence with a square distribution in the assigned angular frequency range.

FIGS. 4A and 4B exemplify, respectively, a segment of signal  $S_2$  and its autocorrelation. FIG. 4C shows the cross correlation  $C(\tau)$  defined similarly to the above example for phase modulation.

It should be noted that the above description for cross correlation is based on digital signal processing. However, dedicated analog circuits that perform cross correlation with variable delays can be designed and constructed to provide a similar to functional operation of the system.

Referring to FIG. 5, there is exemplified a case for the phase modulation of signal  $S_2$ . The figure shows the amplitude of  $C(\tau)$  (i.e. amplitude of cross correlation  $CCA(\tau, \lambda)$ ), obtained for different values of delay  $\tau$ , as a function of distance from the acoustic transducer, where this distance equals to the product of  $\tau$  by the speed of sound in the medium. Three graphs are presented, showing  $CCA(\tau, \lambda)$  calculated from experimentally obtained measured data MD corresponding to a light response at three different wavelengths  $\lambda^1, \lambda^2, \lambda^3$ , respectively.

In this example, three different light sources, at three different wavelengths, illuminate a turbid medium, and a detection unit generates electronic signals indicative of measured data corresponding to light collected at the input port of the detector, for each wavelength used. As can be seen in the figure, the amplitudes of cross correlation signals  $CCA(\tau, \lambda^1)$ ,  $CCA(\tau, \lambda^2)$ ,  $CCA(\tau, \lambda^3)$ , or generally  $CCA(\tau, \lambda^i)$ , at varying distances is different for the three wavelengths. This results from the fact that the light distribution of the three wavelengths in the tissue is different, due to differences in absorption, scattering and index of refraction.

Signal  $CCA(\tau, \lambda^i)$  corresponds to the acoustic distribution or pressure amplitude  $PA(z)$ , and to the light distribution  $LD(\lambda^i)$ .

$$LD(z, \lambda^i) = K * \prod_{\alpha=s,d} \left( 1 + \frac{1}{\mu^i \sqrt{(\vec{r} - \vec{r}_\alpha)^2 + z^2}} \right) \frac{z}{(\vec{r} - \vec{r}_\alpha)^2 + z^2} \exp\left(-\mu^i \sqrt{(\vec{r} - \vec{r}_\alpha)^2 + z^2}\right) \quad (7)$$

where  $K$  is a constant,  $\mu^i = \sqrt{3\mu_a^i(\mu_a^i + \mu_s^i)} \cong \sqrt{3\mu_a^i\mu_s^i}$  is the effective decay rate of light in the medium,  $\mu_a^i$  is the absorption coefficient and  $\mu_s^i$  is the scattering coefficient at wavelength  $\lambda^i$ ; when near infrared light is used, it can be assumed that  $\mu^i \cong \sqrt{3\mu_a^i\mu_s^i}$ ,  $\vec{r}_\alpha$  is either the vector to the source ( $\alpha=s$ ) or to the detector ( $\alpha=d$ ), and  $z$  is the direction parallel to the direction of propagation of the acoustic radiation into the medium.

For example, for a large enough distance  $z$  ( $z = \tau \cdot c_s$ ,  $c_s$  being the speed of sound in the medium) from the body surface (namely larger than the mean free path of light in the medium, and larger than the source detector separation,  $\vec{r}_d - \vec{r}_s$ ), the light distribution  $LD(z, \lambda^i)$  is proportional to  $e^{-2\mu^i z}$  where  $CCA(z, \lambda^i)$  is given by  $CCA(z, \lambda^i) \cong PA(z) I_0^i e^{-2\mu^i z} + C_o$ , where  $I_0^i$  is the initial light intensity upon entry into the medium, and  $C_o$  is an additive constant.

Thus, turning back to FIG. 2B, if the acoustic pressure amplitude PA(z) is known, for example by measuring it with a hydrophone in water, the light distribution LD(z,λ<sup>i</sup>) can be extracted by dividing PA(z) out of CCA(z,λ<sup>i</sup>), after eliminating C<sub>o</sub>. In many practical cases, however, the pressure profile is unknown, for example when the medium consists of different layers with different acoustic impedances. Thus, there is no correspondence between measurements of the pressure profile in water or synthetic phantoms and the correct pressure profile in the measured medium. In such cases, measurements with at least two or generally N different light wavelengths can be performed, and corresponding CCA(z,λ<sup>i</sup>) are used to eliminate the acoustic contribution PA(z) (after eliminating C<sub>o</sub>). This is implemented by dividing measured CCA(z,λ<sup>i</sup>) by measured CCA(z,λ<sup>j</sup>) for i≠j, assuming that the acoustic contribution is the same for all wavelengths, which is a justifiable assumption. Thus, the ratio of the light distributions can be obtained. This ratio is important for example for determining the oxygen saturation of a tissue or blood vessel as will be explained below.

Constant C<sub>o</sub> corresponds to the noise level of the system at the measured frequency bandwidth. For example, one possible way to measure C<sub>o</sub> is to cross correlate measured data MD with a time-reversed signal S<sub>p</sub>(τ-t). Such a correlation results in the same frequency bandwidth, but is completely uncorrelated with measured data MD. Thus, constant C<sub>o</sub> for each wavelength of light can be measured independently and eliminated from signal CCA(z,λ<sup>i</sup>). Alternatively, C<sub>o</sub> can be eliminated by performing the measurements at two different amplitudes of acoustic radiation, and taking the difference between the two corresponding cross correlations.

In the case of a medium irradiated by three different wavelengths:

$$\frac{\tilde{I}^i}{\tilde{I}^j} = \frac{I_0^i}{I_0^j} e^{-2\Delta\mu^{ij}z} \quad [1]$$

where i; j=1; 2; 3 represent the three lasers,  $\tilde{I}=(CCA(z,\lambda^i)-C_o)$  is the amplitude of the signal at distance z, I<sub>0</sub><sup>i</sup>, I<sub>0</sub><sup>j</sup> are the input intensities of the i<sup>th</sup> and j<sup>th</sup> wavelengths respectively and  $\Delta\mu^{ij}=\mu^i-\mu^j$ .

Taking a logarithm of the equation above,  $\Delta\mu^{ij}$  can be obtained:

$$\Delta\mu^{ij} = -\frac{1}{2} \frac{\partial}{\partial z} \ln \left[ \frac{\tilde{I}^i}{\tilde{I}^j} \right] \quad [9]$$

The saturation s is related to the absorption coefficient  $\mu_a^i$  by the following relation:

$$\mu_a^i = \epsilon_{Hb}^i C_{Hb} + \epsilon_{HbO}^i C_{HbO} = C_{tot} (\epsilon_{Hb}^i s + (\epsilon_{HbO}^i - \epsilon_{Hb}^i) s) \quad [10]$$

where C<sub>Hb</sub>, C<sub>HbO</sub> and C<sub>tot</sub> are the concentrations of deoxygenated hemoglobin, oxygenated hemoglobin and the total hemoglobin, respectively, s is the oxygen saturation defined as the ratio between the concentration of oxygenated hemoglobin to the total hemoglobin concentration (i.e.  $s=C_{HbO}/C_{tot}$ ), and  $\epsilon_{Hb}^i$ ,  $\epsilon_{HbO}^i$  are the extinction coefficients at the i<sup>th</sup> wavelength for deoxygenated and oxygenated hemoglobin, respectively, that are known in the literature.

Thus, for any saturation s, the theoretical  $\mu_a^i$  can be calculated using this equation, in order to determine the saturation at different tissue layers. The decay coefficient  $\mu^i$  can be calculated for example from the graphs presented in FIG. 5. If

the scattering coefficient is assumed to be the same for all three wavelengths, the absorption coefficient at each wavelength equals:

$$\mu_a^i = \frac{(\mu^i)^2}{3\mu_s},$$

and the ratio  $\alpha^{ijk}$  can be calculated by:

$$\alpha^{ijk} = \frac{\Delta\mu^{ij}}{\Delta\mu^{ik}} = \sqrt{\frac{\epsilon_{Hb}^j - \epsilon_{Hb}^i + (\epsilon_{HbO}^j - \epsilon_{HbO}^i - \epsilon_{Hb}^j + \epsilon_{Hb}^i)s}{\epsilon_{Hb}^k - \epsilon_{Hb}^i + (\epsilon_{HbO}^k - \epsilon_{HbO}^i - \epsilon_{Hb}^k + \epsilon_{Hb}^i)s}} \quad [11]$$

The following explains how the saturation is calculated by using measured data obtained by three lasers, and using the differences in  $\Delta\mu^{12}$  and  $\Delta\mu^{31}$ :

The extinction coefficients are known from the literature, so that for Sat=1-100% the theoretical values for  $\Delta\mu_{th}=(\Delta\mu_{th}^{12}, \Delta\mu_{th}^{31})$  can be calculated up to the multiplicative constant  $\sqrt{3}\cdot\mu_s^i\cdot C_{tot}$ . The scattering coefficient  $\mu_s^i=\mu_s$  is approximated to be the same for the three lasers, however it may vary with time. In order to compare the experimental value  $\Delta\mu_{ex}=(\Delta\mu_{ex}^{12}, \Delta\mu_{ex}^{31})$  to the theoretical value  $\Delta\mu_{th}$ , the angle between the vectors in the plane that is spanned by  $[\Delta\mu^{12}, \Delta\mu^{31}]$  is determined. For each experimental point there is a certain value of  $\Delta\mu_{ex}$ . The angle between this experimental vector and every theoretical option (corresponding to saturation values of 1%-100%) is calculated. The saturation value that corresponds to  $\Delta\mu_{th}$ , which has the smallest angle to  $\Delta\mu_{ex}$ , is the calculated saturation level. Thus, the saturation is calculated without depending on the factor  $\sqrt{3}\cdot\mu_s^i\cdot C_{tot}$ .

Experimental data of the graphs presented in FIG. 5 was collected when the distance between the illumination and detection units was 3 cm. The peak intensity was obtained at about 9 mm from the skin (there is a 2-3 mm distance between the transducer face and the skin surface in this measurement). In order to map the three dimensional light distribution, different separations between the source and the detectors should be used.

Once the saturation s is determined, the total hemoglobin concentration C<sub>tot</sub> can be determined from measurements of the exponential decay of CCA(z, λ<sup>i</sup>) at the different wavelengths, using the known extinction coefficients for oxygenated and deoxygenated hemoglobin.

It should be noted that, in addition to the oxygen saturation level, other parameters of the tissue and blood composition or parameters can be determined from measurements of CCA(z, λ<sup>i</sup>). Moreover, the present invention provides for using determination of  $\Delta\mu_{ex}$  without relying on measuring CCA(z, λ<sup>i</sup>), for example by using frequency domain spectroscopy or time of flight based measurements, to determine the following parameters independent of the measurement method:

For example, total Hemoglobin content C<sub>tot</sub> can be calculated as follows: Since the angle between the vectors  $\Delta\mu_{th}$  and  $\Delta\mu_{ex}$  corresponds to the calculated saturation, the multiplicative factors (i.e.  $\sqrt{3}\cdot\mu_s^i\cdot C_{tot}$ ) that are neglected in the theoretical calculation of  $\Delta\mu_{th}$  are of no consequence to the saturation value that results from the disclosed algorithm. If there is a change in the total blood concentration, C<sub>tot</sub>, or the scattering coefficient,  $\mu_s$ , without changes in the oxygen saturation level, it will be reflected by the distance of the experimental point from the origin (see Eq. [10]), but the direction of the vector from the origin to the experimental point will remain

the same. Therefore, the total blood concentration can be measured by determining the distance of the experimental  $\Delta\mu_{ex}$  point from the origin. Changes in the scattering coefficient can be extracted using other optical methods, such as time of flight or frequency domain spectroscopy. Consequently, independent measurements of the total blood concentration  $C_{tot}$  and the scattering coefficient  $\mu_s$  can be made.

Another parameter that can be determined from measurements of  $CCA(z, \lambda^i)$  is blood flow. In general, the measured tissue volume contains blood vessels and capillaries. The flow of blood inside these vessels affects the properties of the measured data. The speckle correlation time is affected by the flow, there is a flow dependent Doppler shift in the acoustic waves and other effects may exist. Direct measurement of the speckle correlation time is known to correspond to blood flow velocities [G. Yu et al Journal of Biomedical Optics 2005 10:2]. Thus, the properties of  $CCA(z, \lambda^i)$ , such as the peak amplitude, the noise level  $C_0$  and other parameters are affected by the flow. By monitoring these parameters, as a function of time, changes in the flow rates are extracted. In particular, by monitoring these changes as a function of depth, flow distribution can be determined.

Yet other measurable parameters include differences between arterial and venous contribution to the signal. In this connection, the following should be noted: General Near Infrared Spectroscopy (NIRS) measurements do not distinguish between the arterial, capillary, and venous compartments of blood circulation and thus reflect a weighted average of Hb concentrations within these different blood compartments in the region sampled. For example, in brain, the relative distribution of arterial, capillary, and venous compartments in the cerebral blood volume (CBV) is generally accepted to be approximately 20%, 10%, and 70% respectively. Using this distribution,  $C_{tot}$  in the venous compartment can be isolated as follows:

$$C_{tot} = 0.2[Hb]_a + 0.1[Hb]_c + 0.7[Hb]_v$$

where  $C_{tot}$ ,  $[Hb]_a$ ,  $[Hb]_c$ , and  $[Hb]_v$  are the concentrations of total Hb, arterial Hb, capillary Hb, and venous Hb, respectively. Using the assumption that the capillary concentration of Hb is the mean of arterial and venous concentrations, it is possible to determine  $[Hb]_v$ , given that  $C_{tot}$  can be measured and  $[Hb]_a$  can be calculated from the arterial saturation  $SaO_2$  using measured Hb content of arterial blood and CBV as a measure of the percentage of blood in a given tissue volume.  $SaO_2$  can be measured using a pulse oximeter. Because Hb is generated in the brain solely through the process of  $O_2$  dissociation from  $HbO_2$ , the difference in  $[Hb]_a$  and  $[Hb]_v$  is identical, although opposite in sign, to the difference in  $[HbO_2]_a$  and  $[HbO_2]_v$ , assuming that CBV remains constant during the measurement period.

Yet another parameter that can be determined, based on measurements of  $CCA(z, \lambda^i)$ , is the oxygen extraction fraction (OEF). OEF is the percentage of oxygen extracted from arterial blood in the tissue:

$$OEF = (\text{arterio-venous } O_2 \text{ diff}) / CaO_2, \quad [12]$$

where  $CaO_2$ , the arterial oxygen content, can be calculated from the arterial saturation (measured by a pulse oximeter for example, as explained by Brown D. W. et al. Pediatric Research Vol 54 No 6 2003 pp 861-867); and

$$(\text{arterio-venous } O_2 \text{ diff}) = ([Hb]_v - [Hb]_a) * 1.39 \text{ ml } O_2 / g Hb \quad [13]$$

where  $[Hb]_v$  and  $[Hb]_a$  are defined above.

Therefore, as the total hemoglobin content  $C_{tot}$  can be extracted as explained above, the oxygen extraction fraction in the measured tissue volume can be determined using the preferred embodiment.

Reference is now made to FIGS. 6A-6C schematically illustrating three examples, respectively, of the probe configurations according to further embodiments of the invention. In these examples the probe includes an annular acoustic transducer unit **110** and light input and output ports IP and OP such that at least one of these ports is located within an annular aperture of the acoustic transducer module. In the example of FIG. 6A, a common light guiding unit **310** is used through which fibers **105** and **106**, associated with the light output and input ports OP and IP (i.e. with the lighting and detecting elements), pass. In the example of FIG. 6B, the configuration is generally similar to that of FIG. 6A, but utilizes separate light guiding units **312** and **311** located inside the transducer unit's aperture and associated with lighting and detecting elements, respectively. In the example of FIG. 6C, a light guiding unit **310** carrying an optical fiber **306** associated with light detecting element IP is located inside the transducer's aperture, and a lighting element OP is located outside the transducer unit adjacent thereto being connected to a light source or control unit via an appropriate connection **105**. The location of elements corresponding to lighting elements and light detecting elements can be interchanged.

FIGS. 7A and 7B schematically illustrate two more examples, respectively, of a probe configuration according to the invention. In both of these examples, an acoustic transducer unit **110** is configured for passage therethrough of at least one light guiding unit associated with light detecting element(s), and an illumination unit includes a plurality of lighting elements located outside the transducer arrangement adjacent thereto. The lighting elements are arranged in a circular array around the light detecting element(s). In the example of FIG. 7A, a single light detecting element IP is used being located in an aperture of the transducer and associated with an appropriate light guiding unit **310** (e.g. fiber), and a circular array of twelve lighting units **320A-320L** is used. In the example of FIG. 7B, an illumination unit includes eight light detecting elements are used located in corresponding spaced-apart apertures of the transducer. The light detecting elements include a central element **310A** and elements **310B** arranged in a circular array around element **310A**. The location of elements corresponding to lighting elements and light detecting elements can be interchanged.

Reference is made to FIGS. 8A and 8B exemplifying the transducer's assemblies including light guides.

FIG. 8A shows a transducer's assembly **500** that includes a light guiding element in the center. The assembly may be configured such that there is no acoustic contact between the light guiding element (an optical fiber) and the piezoelectric element that generates the acoustic waves. Assembly **500** comprises a casing **501** that encapsulates piezoelectric element **502** and light guide **510**. To allow for light delivery through piezoelectric element **502**, the piezoelectric element **502** is formed with an optical window **509** having a diameter large enough to provide light propagation from/to light guide **510** through this optical window **509**. Optical window **509** may be a physical hole, or may be a transparent opening in the piezoelectric element. Piezoelectric element **502** may also be completely transparent to light, and therefore optical window **509** may be a part of piezoelectric element **502**. In addition, the optical window **509** may include a transparent optical rod that will allow light propagation through. In case the optical window **509** is a physical hole, an additional optical window

503 can also be used to seal this hole 509. Further provided is a support 511 configured to allow aligning of the optical window 509 with the aperture of light guide 510. Electric wires 505 and 506 are coupled to the two electrodes (not shown) on the piezoelectric element 502, for to generating acoustic waves. These two wires are connected to cable 107 (see FIG. 1) used to deliver electrical signals from the signal generator (125 in FIG. 1).

FIG. 8B shows an assembly 551 including a casing 501 that encapsulates piezoelectric element 502 and optical guide 510. Optical guide 510 enters the casing 501 through an opening (not shown) and is supported by a support structure 515 inside the casing. Another support structure 556, positioned inside the casing, supports a prism 575. The prism is positioned such that light coupled from optical guide 510 is directed towards a further optical guide 565. This optical guide 565 is positioned inside a through hole (optical window) 509. The piezoelectric element 502 is supported by a support structure 555 that prevents acoustic coupling to the casing walls. Electric wires 505 and 506 are coupled to the two electrodes (not shown) on the piezoelectric element 502, for generating acoustic waves. Alternatively, the optical guide 510 may be input from the side its end cut at an angle to allow for the light trapped inside the fiber to reflect at a 90° angle, i.e. a side firing fiber, instead of propagating through the prism 575.

The above configurations allow for selecting the light input and output ports for use in measurements so as to provide an optimal distance between the operative input and output ports. This is associated with the following: As the distance between the light source and light detector is reduced (to ~zero), the contribution of light reflected from superficial layers to the untagged signal in the detected light is higher than in the case of larger source-detector distance. Therefore, in order to detect the tagged light from deep layers, the detection unit preferably includes an electronic filter, one of the kind that filters the low frequency signals generated in response to untagged light from the signals corresponding to tagged light (at higher frequency corresponding to the ultrasound bandwidth). Reducing the source-detector distance also improves the accuracy in calculating the optical properties of the medium, improving the determination of the desired parameter(s), e.g. calculation of the oxygen saturation level. When the source-detector distance is small, the differences in the optical paths of the shallow photons and the deep photons (that are used to calculate the optical attenuation coefficient) depend primarily on the distance traveled in the z direction (along the radiation direction towards the region of interest). Whereas for larger source-detector distance, the optical attenuation also depends on the differences in the x and y dimensions, and thus degrades the dependence on the z direction, rendering the to calculations more complex.

As a result of the ultrasound beam interacting with the light, the signal that we obtain includes an integral over  $\vec{r}$  of  $LD(\lambda^i)$  within  $V_{US}$  the volume of the ultrasound beam

$$I = \int_{V_{US}} d\vec{r} LD(\lambda^i).$$

This integral will clearly depend on  $\vec{r}_s$  and  $\vec{r}_d$ . The expression for the light distribution  $LD(z)$  (Eq [7]) shows that its integral over  $r$  depends on the source-detector distance  $r_{sd}$ ,

such that as distance  $r_{sd}$  decreases the light distribution  $LD(z)$  will depend primarily on the exponential decay.

In addition, at large source-detector distances, there are many more scattering events of photons reaching the detector than for small source-detector distances. Thus, as different wavelengths are scattered differently by the tissue and cells, the difference between the optical paths of the different wavelengths increases as the source-detector distance increases. Since it was assumed above that the scattering coefficient is the same, the error in making this assumption increases as the source-detector distance increases.

Thus, the present invention provides for an effective technique for determining one or more desired parameters of a subject using an acoustic tagging of light, where acoustic radiation is generated in the form of a continuous wave, which is coded (modulated) to vary in accordance with a predetermined function of at least one parameter of the acoustic radiation which is non-periodic over a measurement time interval. The invention also provides an optimized probe configuration to obtain a required distance between the light input and output ports used in the measurements.

Those skilled in the art will readily appreciate that various modifications and changes can be applied to the embodiments of the invention as hereinbefore described without departing from its scope defined in and by the appended claims. In the method claims that follow, alphabetic characters and numerals used to designate claim steps are provided for convenience only and do not imply any particular order of performing the steps.

The invention claimed is:

1. A probe device for use in noninvasive monitoring of at least one parameter of a region of interest in a subject's body, the probe device comprising a support structure and a control unit wherein:

35 said support structure configured to be put in contact with the body part, the support structure comprising:  
at least one acoustic output port associated with an acoustic unit and

an arrangement of light ports comprising light input and output ports associated with respectively a detection assembly and an illumination assembly, said arrangement of light ports comprising at least one light output port located within an aperture of the acoustic unit, and a plurality of the light input ports located around said at least one light output port, wherein location of said light output and input ports is interchangeable, said arrangement of the light ports thereby defining pairs of the light output and input ports characterized by different source-detector distances  $r_{sd}$  and enabling illumination and detection of light using at least one selected operative pair of the light input and output ports to illuminate a region in the subject's body by illuminating light coming from at least one light output port, irradiate a region in the body with acoustic radiation coming from the at least one acoustic output port, and collect light scattered from the illuminated region in the body by at least one light input port; wherein when the probe device is operated, overlapping between the illuminating light and the acoustic radiation induces tagging of light scattered from an overlapping region by the acoustic radiation;

wherein said control unit is connected to said arrangement of light ports and the at least one acoustic output port, and is preprogrammed to manage a measurement session by selecting the at least one operative pair of the operative light input and output ports with respect to the at least one acoustic output port to provide an operating condition of the probe during the measurement session,

the operating condition corresponding to at least one selected value of the source detector distance  $r_{sd}$  is sufficiently small such that a difference in optical paths of shallow photons and deep photons in the illuminating light defining an optical attenuation coefficient depends on a distance traveled in a direction  $z$  and not on differences in optical paths in  $x$  or  $y$  dimensions, and light collected by said at least one operative light input port comprises the scattered light originated in the overlapping region, thereby enabling improved-accuracy calculation of the optical attenuation coefficient from light collected by the operative light input port and determination of at least one parameter of the region of interest, wherein  $z$  is a direction parallel to a direction of propagation of the acoustic radiation towards the region of interest.

2. A probe of claim 1, comprising an electronic filter, connected to the at least one light input port and configured and operable for receiving the collected light and filtering low frequency signals therein to thereby extract signals corresponding to the scattered tagged light.

3. A probe of claim 1, wherein the control unit comprises an electronic filter, connected to the at least one light input port and configured and operable for receiving the collected light and filtering low frequency signals therein to thereby extract signals corresponding to the scattered tagged light.

4. A probe device of claim 1, wherein the control unit comprises: a data processing and analyzing utility configured and operable for receiving and analyzing data indicative of the collected light and generating output data indicative of at least one parameter of the subject, and a data presentation utility responsive to the output data of the processing and analyzing utility for presenting said at least parameter to user.

5. A probe device of claim 1, wherein said at least one parameter comprises at least one of the following: blood flow; oxygen saturation; and hemoglobin concentration.

6. A probe device of claim 1, wherein the control unit is configured and operable for determining multiple parameters of the subject, the control unit comprises a display configured to display the multiple parameters sequentially or concurrently to a user.

7. A probe device of claim 1, wherein said arrangement on the support structure comprises a single acoustic port.

8. A probe device of claim 1, wherein said arrangement on the support structure comprises a plurality of the acoustic ports arranged in a spaced apart relationship on the support structure.

9. A probe device of claim 1, wherein said arrangement on the support structure comprises a plurality of the light output ports at different locations along the support structure.

10. A probe device of claim 1, wherein said arrangement on the support structure comprises a plurality of the light input ports at different locations along the support structure.

11. A probe device of claim 1, wherein the at least one light input port and the at least light output port accommodated within said aperture.

12. A probe device of claim 1, wherein the at least one light input port is located within said aperture of the acoustic unit, and multiple light output ports are arranged in an essentially circular array outside the acoustic unit around said at least one light input port.

13. A probe device of claim 1, wherein the at least one light output port is located within said aperture of the acoustic unit, and multiple light input ports are arranged in an essentially circular array outside the acoustic unit around said at least one light output port.

14. A system for use in determining one or more parameters of a subject, the system comprising:

the probe device of claim 1; and

an external control system which comprises the illumination assembly, the detection assembly, and the acoustic unit, and which is connected to said control unit of the probe device.

15. A system of claim 14, wherein the acoustic unit comprises a signal generator and an acoustic transducer arrangement, said signal generator being configured and operable to generate the acoustic waves comprising at least one coded acoustic wave in the form of a predetermined function of at least one parameter of the acoustic radiation varying over time during a predetermined time interval used for measurements.

16. A system of claim 15, wherein said coded acoustic wave is a continuous wave and said predetermined function has a narrow autocorrelation.

\* \* \* \* \*

专利名称(译)	用于非侵入性地监测受试者状况的系统和方法		
公开(公告)号	<a href="#">US9237850</a>	公开(公告)日	2016-01-19
申请号	US13/402275	申请日	2012-02-22
[标]申请(专利权)人(译)	OR-NIM医疗有限公司		
申请(专利权)人(译)	OR-NIM MEDICAL LTD.		
当前申请(专利权)人(译)	OR-NIM MEDICAL LTD.		
[标]发明人	METZGER YAACOV ROKNI MICHAL PERY SHECHTER REVITAL		
发明人	METZGER, YAACOV ROKNI, MICHAL PERY-SHECHTER, REVITAL		
IPC分类号	A61B8/00 A61B5/00 G01N21/17 A61B5/1455		
CPC分类号	A61B5/0059 A61B5/0097 G01N21/1702 A61B5/1455 G01N21/1717 G01N21/4795 G01N21/49 G01N2021/1727		
审查员(译)	LUONG , PETER		
其他公开文献	US20120150014A1		
外部链接	<a href="#">Espacenet</a> <a href="#">USPTO</a>		

#### 摘要(译)

提出了一种用于确定受试者的一个或多个参数的方法和系统。用声学标记辐射照射受试者的感兴趣区域，声学标记辐射包括至少一个声学标记光束。用至少一个预定频率范围的电磁束照射感兴趣区域的至少一部分。检测感兴趣区域的至少一部分的电磁辐射响应，并产生指示其的测量数据。检测到的响应包括由声辐射标记的电磁辐射。这使得能够处理指示检测到的电磁辐射响应的测量数据，以确定对应于电磁辐射已经被声辐射标记的介质中的位置的区域中的对象的至少一个参数，并输出指示数据。至少一个确定的参数。

A method and system are presented for use in determining one or more parameters of a subject. A region of interest of the subject is irradiated with acoustic tagging radiation, which comprises at least one acoustic tagging beam. At least a portion of the region of interest is irradiated with at least one electromagnetic beam of a predetermined frequency range. Electromagnetic radiation response of the at least portion of the region of interest is detected and measured data indicative thereof is generated. The detected response comprises elec-