



US008975233B2

(12) **United States Patent**
Stein et al.

(10) **Patent No.:** **US 8,975,233 B2**
(45) **Date of Patent:** ***Mar. 10, 2015**

- (54) **METHODS FOR RENAL DENERVATION**
- (75) Inventors: **Emily A. Stein**, San Leandro, CA (US);
Kondapavulur T. Venkateswara-Rao,
San Jose, CA (US); **Michael A. Evans**,
Palo Alto, CA (US)
- (73) Assignee: **Northwind Medical, Inc.**, San Jose, CA
(US)
- (*) Notice: Subject to any disclaimer, the term of this
patent is extended or adjusted under 35
U.S.C. 154(b) by 338 days.

This patent is subject to a terminal dis-
claimer.
- (21) Appl. No.: **13/014,700**
- (22) Filed: **Jan. 26, 2011**
- (65) **Prior Publication Data**
US 2011/0182912 A1 Jul. 28, 2011
- Related U.S. Application Data**
- (60) Provisional application No. 61/336,838, filed on Jan.
26, 2010.

- 6,860,867 B2 3/2005 Seward et al.
- 6,978,174 B2 12/2005 Gelfand et al.
- 7,070,606 B2 7/2006 Seward
- 7,127,284 B2 10/2006 Seward
- 7,155,284 B1 12/2006 Whitehurst
- 7,162,303 B2 1/2007 Levin et al.
- 7,363,076 B2 4/2008 Yun et al.
- 7,465,298 B2 12/2008 Seward et al.
- 7,547,294 B2 6/2009 Seward et al.
- 7,559,923 B2 7/2009 Seward et al.
- 7,615,049 B2 11/2009 West et al.
- 7,647,115 B2 1/2010 Levin et al.
- 7,653,438 B2 1/2010 Deem et al.
- 7,666,163 B2 2/2010 Seward et al.
- 7,670,329 B2 3/2010 Flaherty et al.
- 7,691,080 B2 4/2010 Seward et al.
- 7,717,948 B2 5/2010 Demarais et al.
- 7,744,584 B2 6/2010 Seward et al.
- 7,756,583 B2 7/2010 Demarais et al.
- 7,853,333 B2 12/2010 Demarais
- 7,873,417 B2 1/2011 Demarais et al.
- 7,879,011 B2 2/2011 Chang
- 8,131,371 B2 3/2012 Demarais et al.
- 8,131,372 B2 3/2012 Levin et al.
- 8,145,316 B2 3/2012 Deem et al.
- 8,145,317 B2 3/2012 Demarais et al.
- 8,150,519 B2 4/2012 Demarais et al.
- 8,150,520 B2 4/2012 Demarais et al.
- 8,175,711 B2 5/2012 Demarais et al.
- 2002/0072706 A1 6/2002 Hiblar et al.
- 2002/0115992 A1 8/2002 Utley et al.

(Continued)

- (51) **Int. Cl.**
A61K 31/704 (2006.01)
A61M 25/00 (2006.01)
A61K 31/7048 (2006.01)
A61B 5/0215 (2006.01)
A61B 5/00 (2006.01)
A61B 17/22 (2006.01)
A61B 19/00 (2006.01)
A61M 25/04 (2006.01)
A61M 25/10 (2013.01)
- (52) **U.S. Cl.**
CPC **A61M 25/0084** (2013.01); **A61K 31/7048**
(2013.01); **A61B 5/0215** (2013.01); **A61B**
5/4839 (2013.01); **A61B 2017/22054** (2013.01);
A61B 2017/22061 (2013.01); **A61B 2017/22067**
(2013.01); **A61B 2019/5276** (2013.01); **A61B**
2019/528 (2013.01); **A61M 25/04** (2013.01);
A61M 2025/0086 (2013.01); **A61M 2025/0087**
(2013.01); **A61M 2025/1047** (2013.01)
USPC **514/25**; 514/17.7; 424/137.1

- (58) **Field of Classification Search**
None
See application file for complete search history.

- (56) **References Cited**
U.S. PATENT DOCUMENTS
4,578,061 A 3/1986 Lemelson
5,354,279 A 10/1994 Höfling
5,681,281 A 10/1997 Vigil et al.
5,693,029 A 12/1997 Leonhardt
5,746,716 A 5/1998 Vigil et al.
6,217,554 B1 4/2001 Green
6,302,870 B1 10/2001 Jacobsen et al.
6,692,466 B1 2/2004 Chow et al.
6,849,597 B2 2/2005 Murata et al.

FOREIGN PATENT DOCUMENTS

- WO WO 8403623 A1 9/1984
- WO WO 2004030718 A2 4/2004

(Continued)

OTHER PUBLICATIONS

- PCT Application No. PCT/US2011/022653 (EVANS001PCT),
International Search Report and Written Opinion, Apr. 11, 2011.
- Converse et al. Sympathetic overactivity in patients with chronic
renal failure. N. Engl. J. Med., Dec. 31, 1992, vol. 327, No. 27, pp.
1912-1918.

(Continued)

Primary Examiner — Robert C Hayes

(57) **ABSTRACT**

Various agents are described to denerve, modulate, or otherwise affect the renal nerves and other neural tissue. Also, various delivery devices are described to deliver an agent locally to the renal nerves. The delivery devices are positioned in the renal artery and penetrate into the wall of the renal artery to deliver the agent to the renal nerves. The delivery devices may be used to deliver the agent according to longitudinal position, radial position, and depth of the renal nerves relative to the renal artery. In addition, various methods are described to denervate, modulate, or otherwise affect the renal nerves and other neural tissue.

10 Claims, 20 Drawing Sheets

(56)

References Cited

OTHER PUBLICATIONS

U.S. PATENT DOCUMENTS

2003/0171734 A1 9/2003 Seward et al.
 2004/0059179 A1 3/2004 Maguire et al.
 2004/0064093 A1 4/2004 Hektner et al.
 2004/0156931 A1 8/2004 Burch et al.
 2004/0162542 A1 8/2004 Wilber et al.
 2005/0182071 A1 8/2005 Seward et al.
 2005/0245862 A1 11/2005 Seward et al.
 2006/0189941 A1 8/2006 Seward et al.
 2006/0217680 A1 9/2006 Barath
 2006/0259005 A1 11/2006 Konstantino et al.
 2007/0083239 A1 4/2007 Demarais et al.
 2007/0112327 A1 5/2007 Yun et al.
 2007/0129720 A1 6/2007 Demarais et al.
 2007/0129760 A1 6/2007 Demarais et al.
 2007/0129761 A1 6/2007 Demarais et al.
 2007/0213761 A1 9/2007 Murphy et al.
 2007/0250035 A1 10/2007 El-Nounou et al.
 2008/0004596 A1 1/2008 Yun et al.
 2008/0213331 A1 9/2008 Gelfand et al.
 2009/0054527 A1 2/2009 Burch et al.
 2009/0062359 A1 3/2009 Burch et al.
 2009/0076409 A1 3/2009 Wu et al.
 2009/0111792 A1 4/2009 Burch et al.
 2009/0270906 A1 10/2009 Hossainy
 2010/0010567 A1 1/2010 Deem et al.
 2010/0222854 A1 9/2010 Demarais
 2010/0249773 A1 9/2010 Clark et al.
 2010/0249859 A1 9/2010 DiLorenzo
 2011/0104060 A1 5/2011 Seward
 2011/0104061 A1 5/2011 Seward
 2011/0112400 A1 5/2011 Emery et al.
 2011/0200171 A1 8/2011 Beetel et al.
 2011/0207758 A1 8/2011 Sobotka et al.
 2011/0208173 A1 8/2011 Sobotka et al.
 2011/0208175 A1 8/2011 Sobotka et al.
 2011/0264011 A1 10/2011 Wu et al.
 2011/0264075 A1 10/2011 Leung et al.
 2012/0130289 A1 5/2012 Demarais et al.
 2012/0130345 A1 5/2012 Levin et al.
 2012/0197198 A1 8/2012 Demarais et al.

FOREIGN PATENT DOCUMENTS

WO WO 2007127488 A1 11/2007
 WO WO2009103932 A1 * 8/2009
 WO WO 2010078175 A1 7/2010

Xiao et al. Ionic mechanism of ouabain-induced concurrent apoptosis and necrosis in individual cultured cortical neurons. *J. Neurosci.*, Feb. 15, 2002, vol. 22, No. 4, pp. 1350-1362.
 Schlaich et al. Renal sympathetic-nerve ablation for uncontrolled hypertension. *N. Engl. J. Med.*, Aug. 27, 2009, vol. 361, No. 9, pp. 932-934.
 Schlaich et al. Renal denervation as a therapeutic approach for hypertension. *Hypertension*, Dec. 2009, vol. 54, pp. 1195-1201.
 Esler. Pathophysiology of the human sympathetic nervous system in cardiovascular diseases: the transition from mechanisms to medical management. *J. Appl. Physiol.*, Feb. 2010, vol. 108, pp. 227-237.
 Esler et al. Point: Chronic activation of the sympathetic nervous system is the dominant contributor to systemic hypertension. *J. Appl. Physiol.*, Dec. 2010, vol. 109, pp. 1996-1998.
 Prescribing Information, DigiFab Digoxin Immune Fab (Ovine), BTG International Inc., Jan. 2012. <http://www.digifab.us/viewpdf.do?documentId=3>.
 Product Monograph, DIGIBIND Digoxin Immune Fab (Ovine), GlaxoSmithKline Inc., May 2009. http://www.gsk.ca/english/docs-pdf/Digibind_PM_20090525_EN.pdf.
 Antibody Resource, Digoxin Antibodies (including mouse, rabbit, sheep, and goat), <http://www.antibodyresource.com/search/Antibodies/2d250441-cff9-5c2a-8fd9-73a808ceac7b/digoxin> (retrieved Apr. 28, 2014).
 Sigma-Aldrich, Inc., Product Information, Monoclonal Anti-Digoxin (mouse), <http://www.sigmaaldrich.com/content/dam/sigma-aldrich/docs/Sigma/Datasheet/3/d8156dat.pdf> (retrieved Apr. 28, 2014).
 MyBioSource, Inc., Datasheet, Digoxin antibody (mouse), http://www.mybiosource.com/datasheet.php?products_id=190115&pdf=true (retrieved Apr. 28, 2014).
 PCT Application No. PCT/US2012/062006 (NORTH004PCT), International Search Report and Written Opinion, Feb. 14, 2013.
 PCT Application No. PCT/US2013/039904 (NORTH005PCT), International Search Report and Written Opinion, Aug. 13, 2013.
 DiBona GF. Nervous kidney. Interaction between renal sympathetic nerves and the renin-angiotensin system in the control of renal function. *Hypertension*, Dec. 2000;36(6):1083-8, PMID: 11116129.
 Tegner R et al. Morphological study of peripheral nerve changes induced by chloroquine treatment. *Acta Neuropathol*, 1988;75(3):253-60, PMID:2831692.
 PCT application PCT/US2014/030804, Oct. 16, 2014, ISR/WO.
 Riaz et al., Digoxin Use in Congestive Heart Failure, *Drugs*, vol. 55, No. 6, pp. 747-758, Jun. 1998.

* cited by examiner

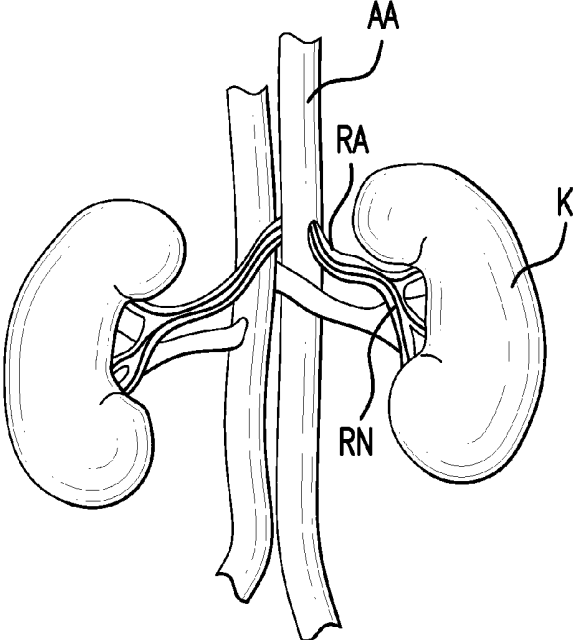

FIG. 1A

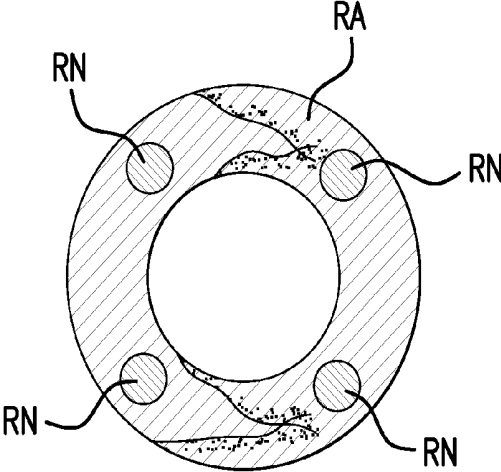

FIG. 1B

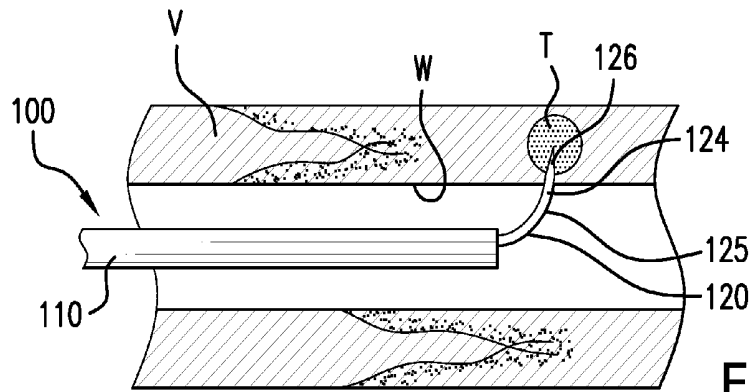

FIG. 2A

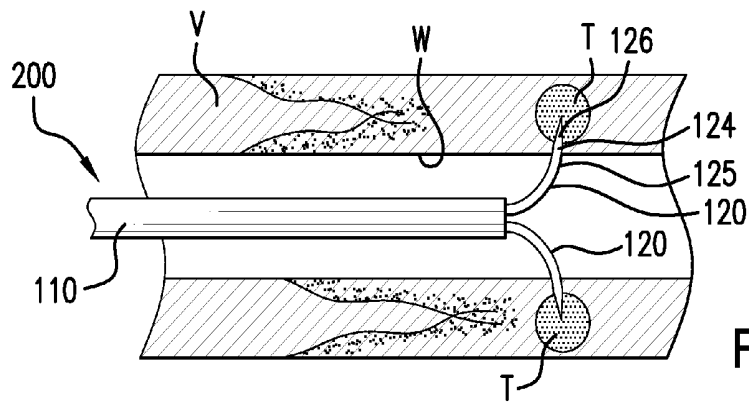

FIG. 2B

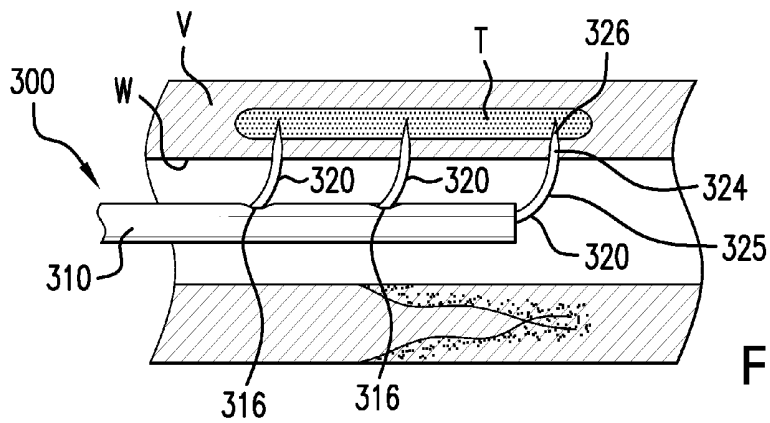

FIG. 2C

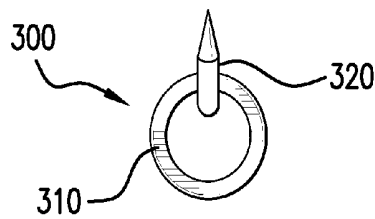

FIG. 2D

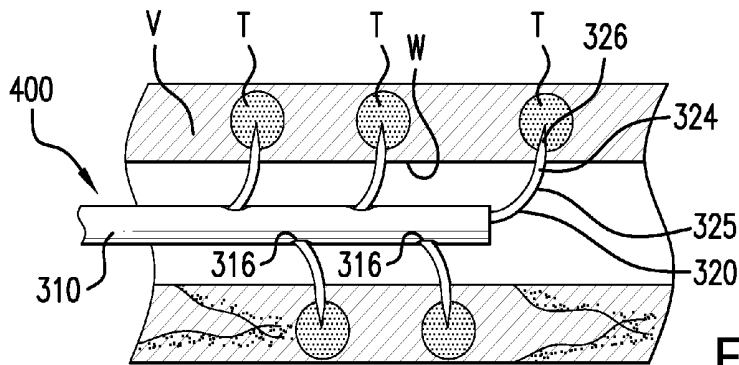

FIG. 2E

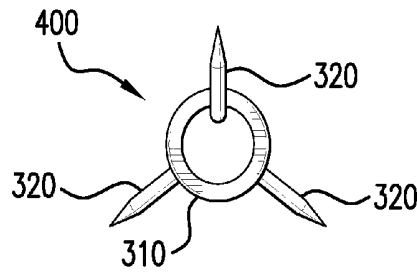

FIG. 2F

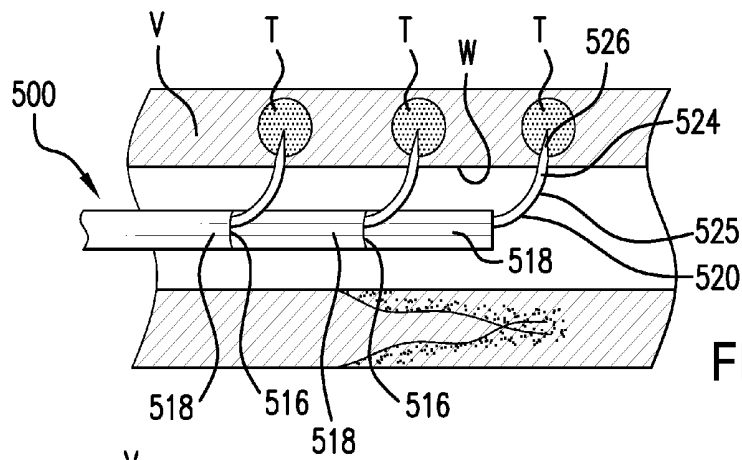

FIG. 2G

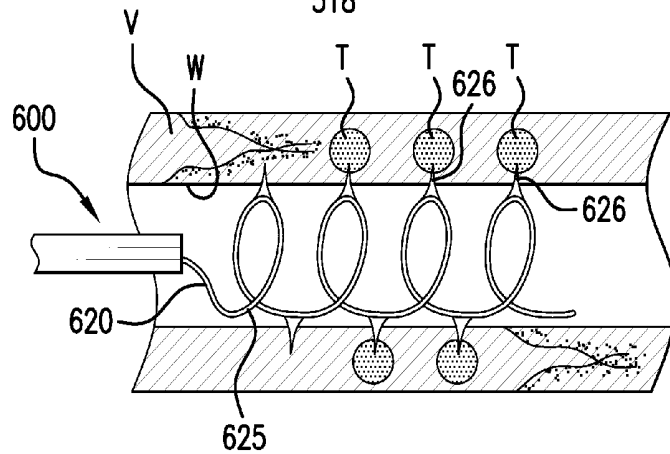

FIG. 2H

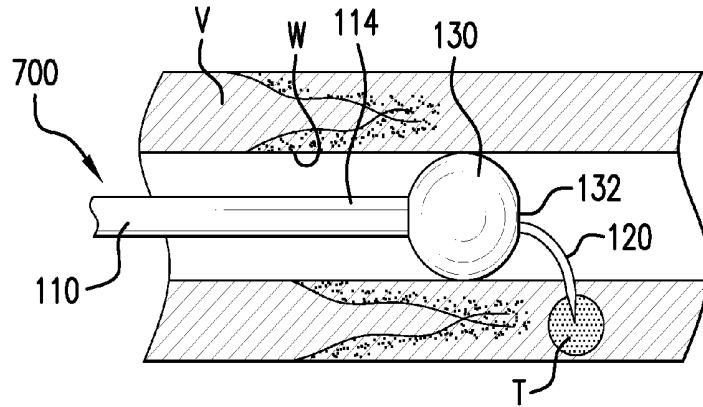

FIG. 3A

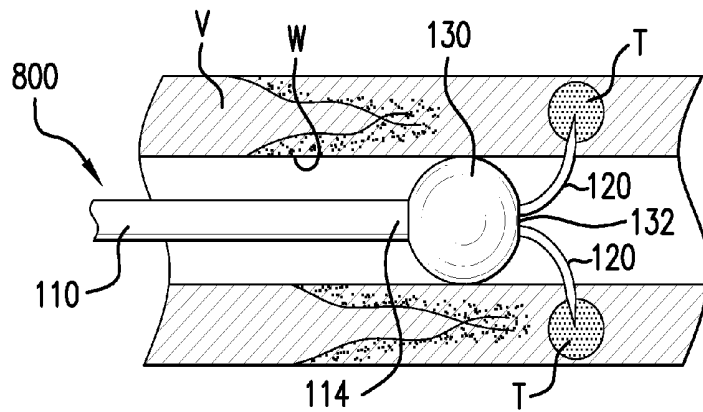

FIG. 3B

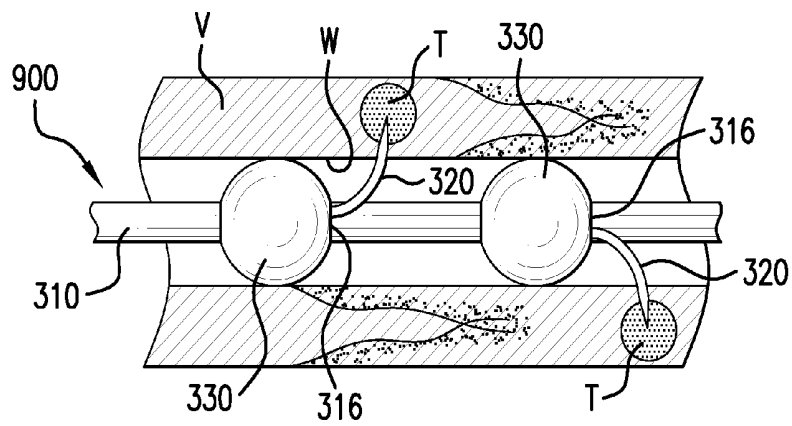

FIG. 3C

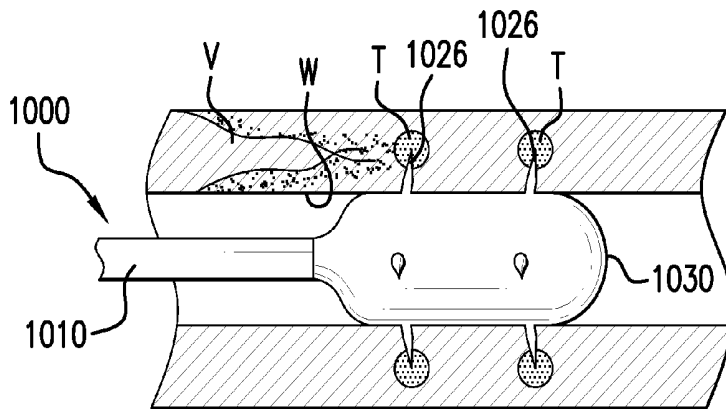

FIG. 3D

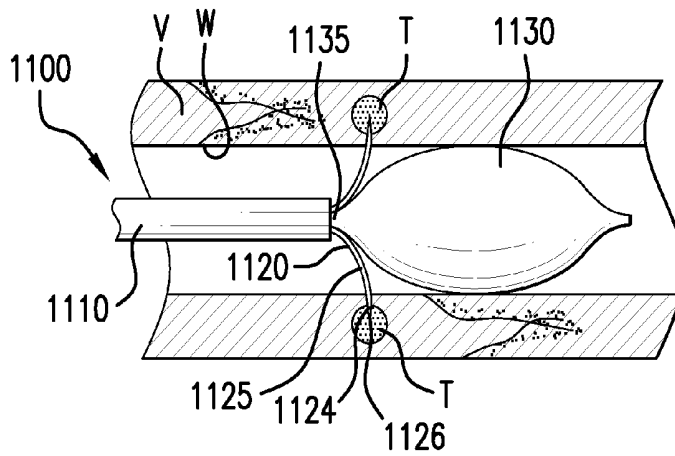

FIG. 3E

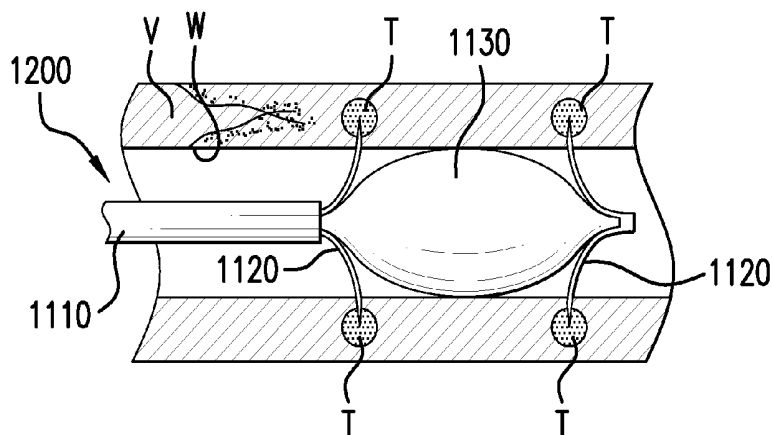

FIG. 3F

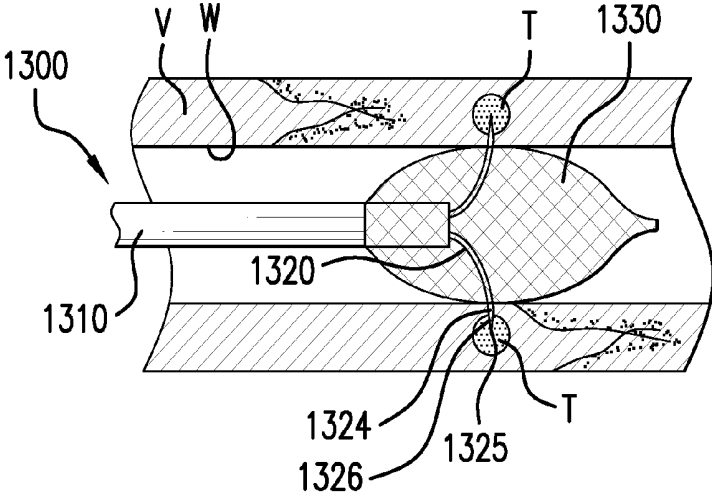

FIG.3G

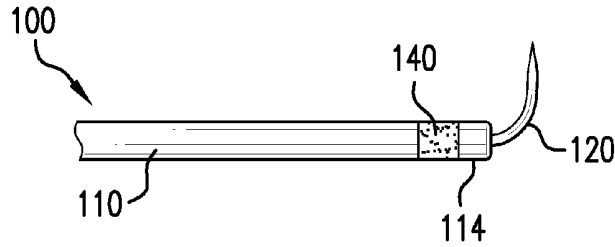

FIG. 4A

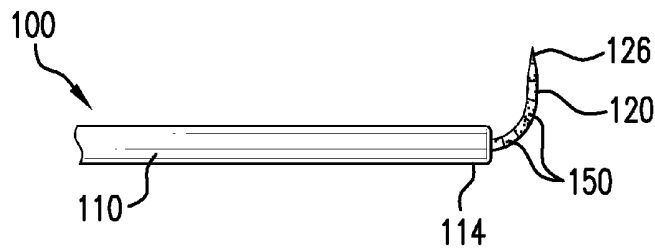

FIG. 4B

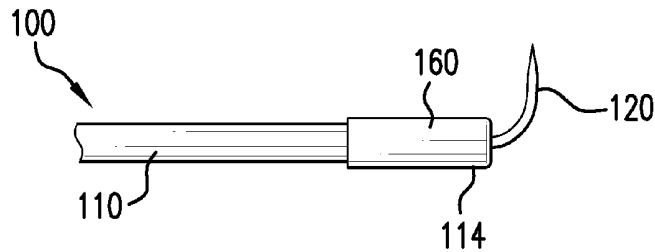

FIG. 4C

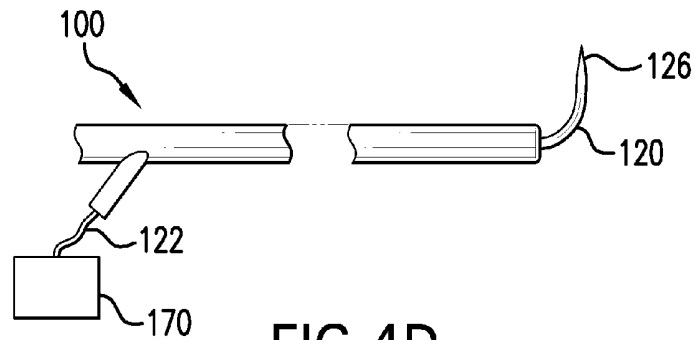

FIG. 4D

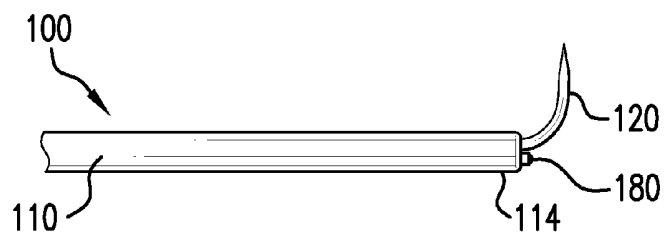

FIG. 4E

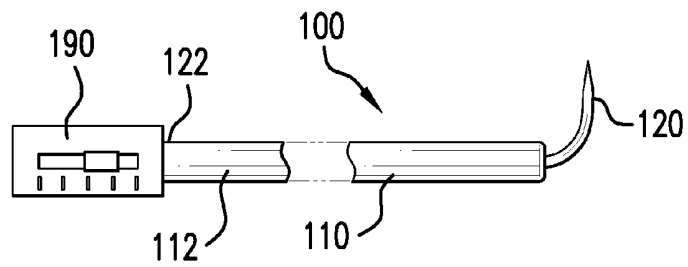

FIG. 4F

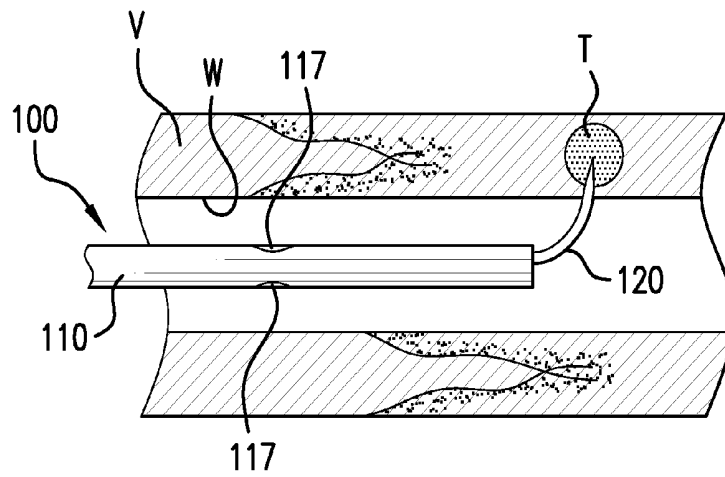

FIG. 5A

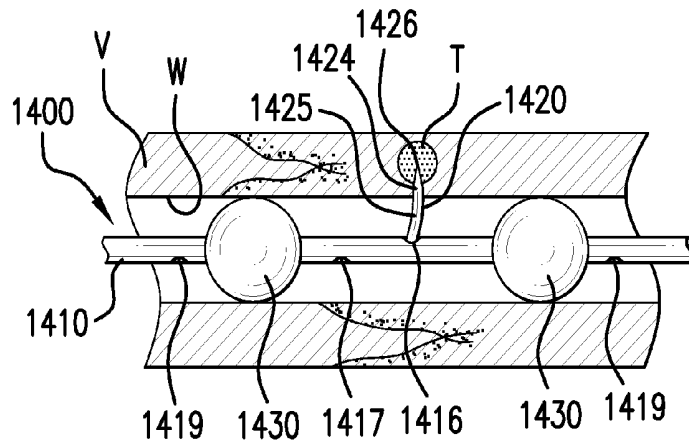

FIG. 5B

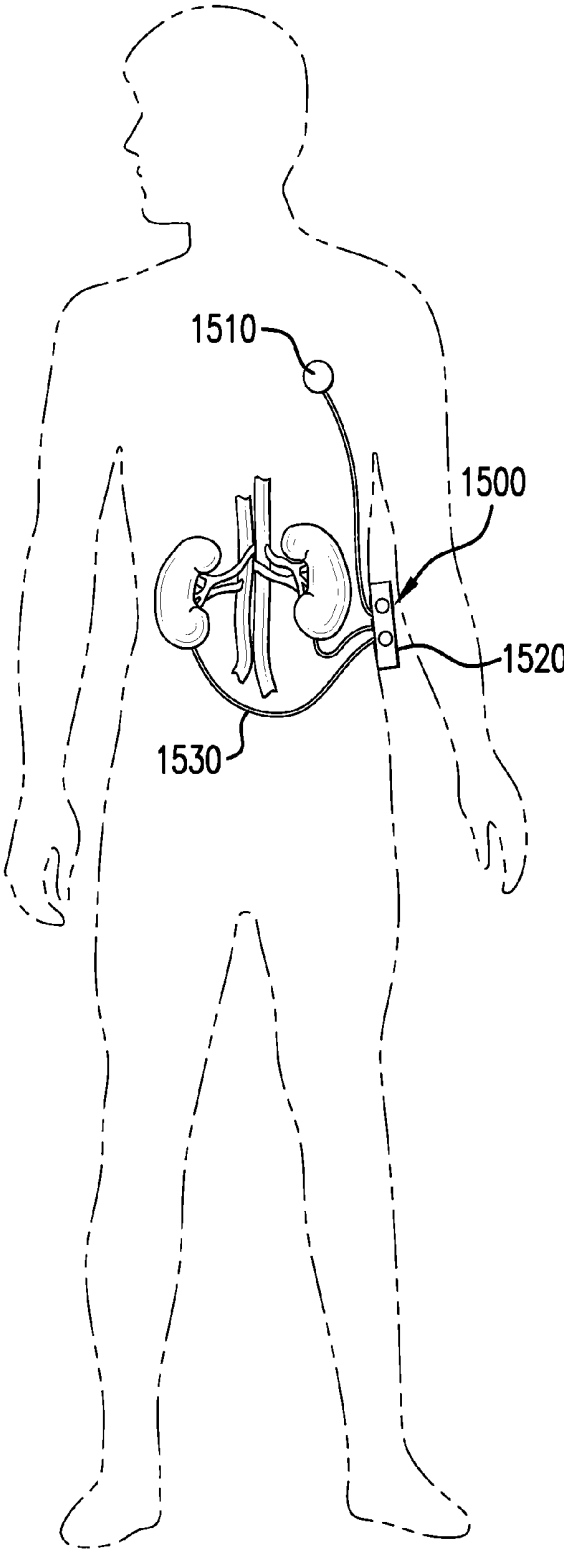

FIG. 6

1600

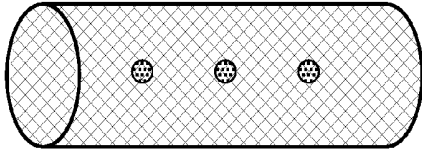

FIG. 7A

1700

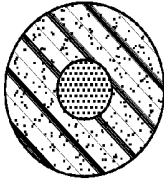

FIG. 7B

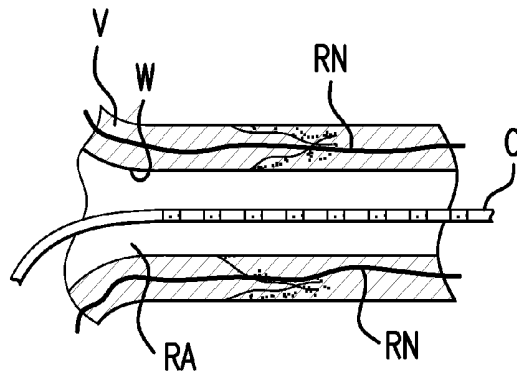

FIG. 8A

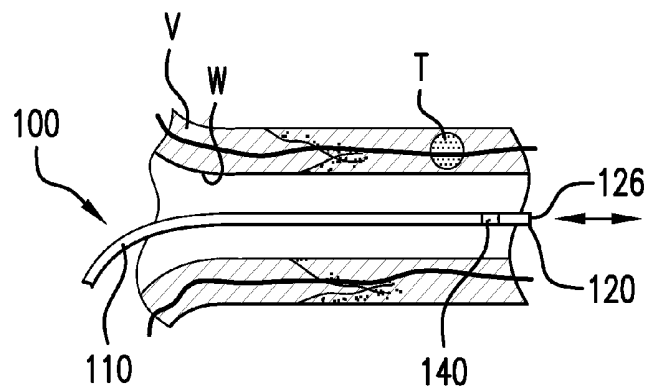

FIG. 8B

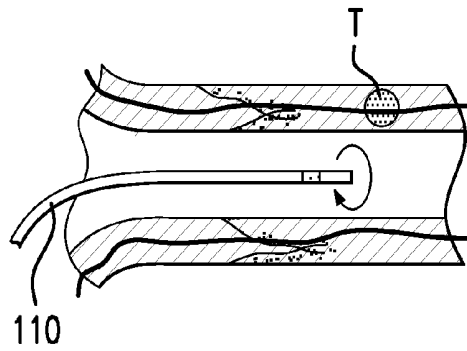

FIG. 8C

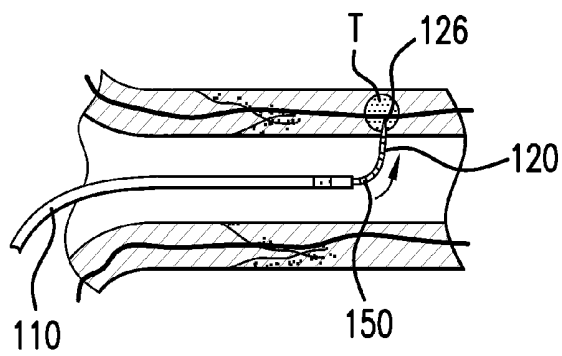

FIG. 8D

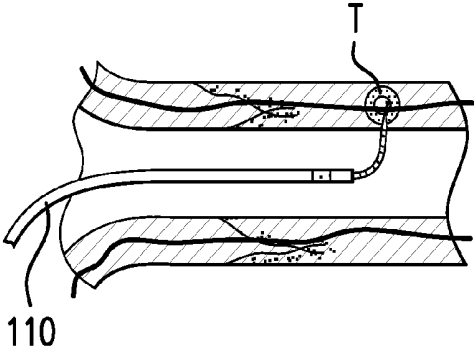

FIG. 8E

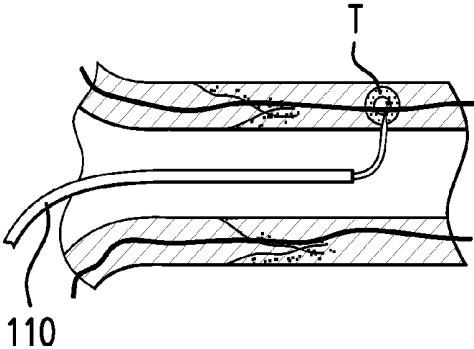

FIG. 8F

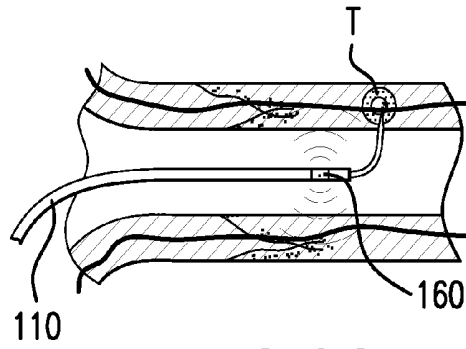

FIG. 8G

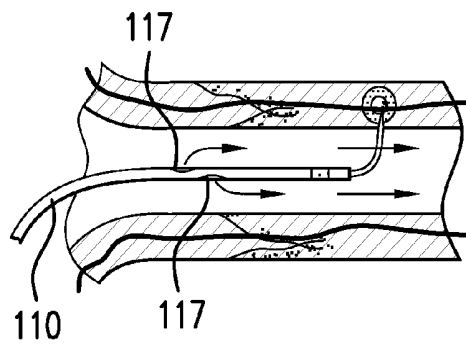

FIG. 8H

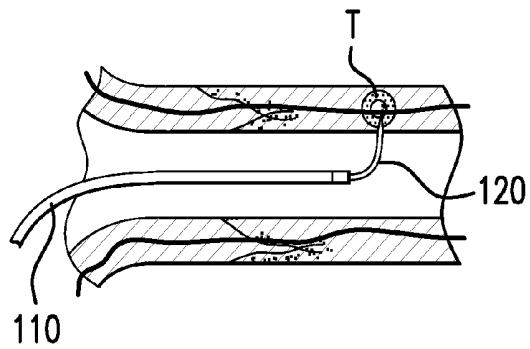

FIG. 8I

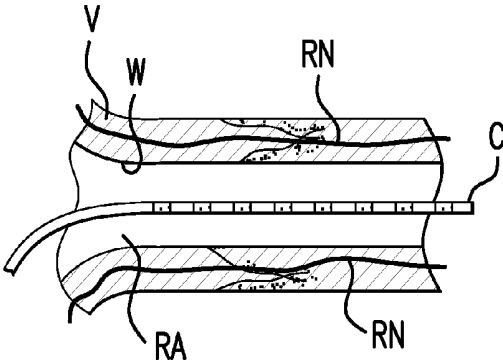

FIG. 9A

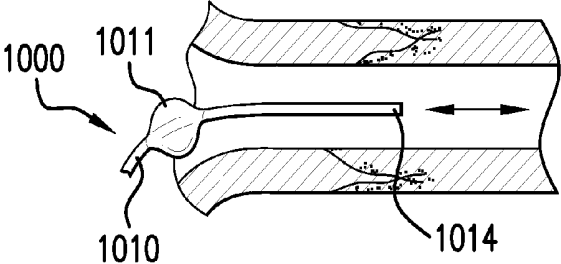

FIG. 9B

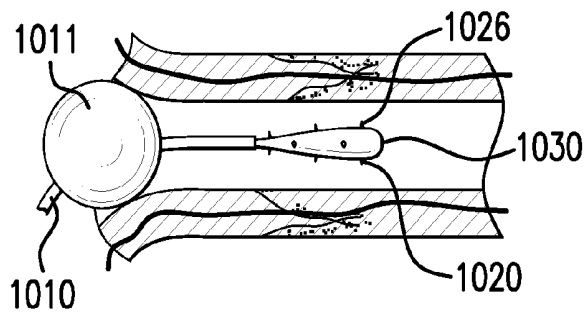

FIG. 9C

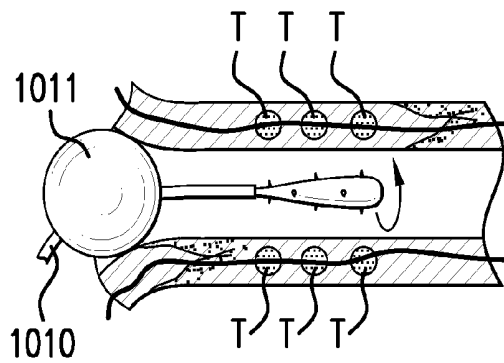

FIG. 9D

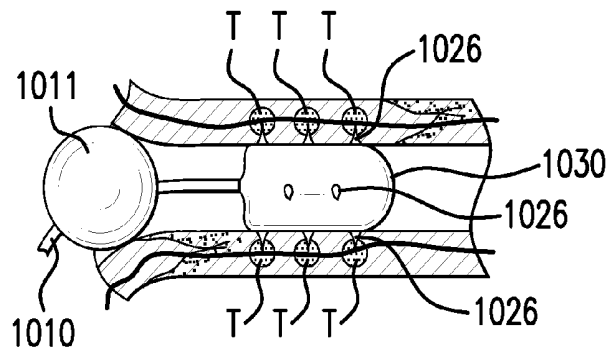

FIG. 9E

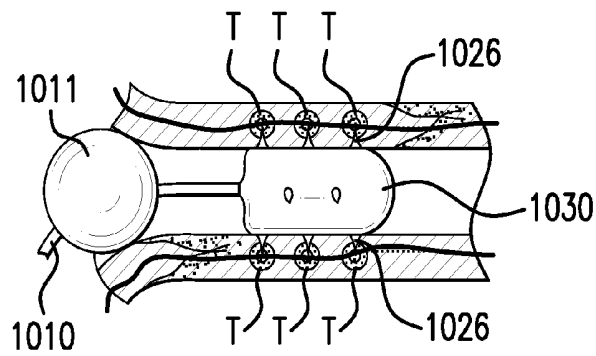

FIG. 9F

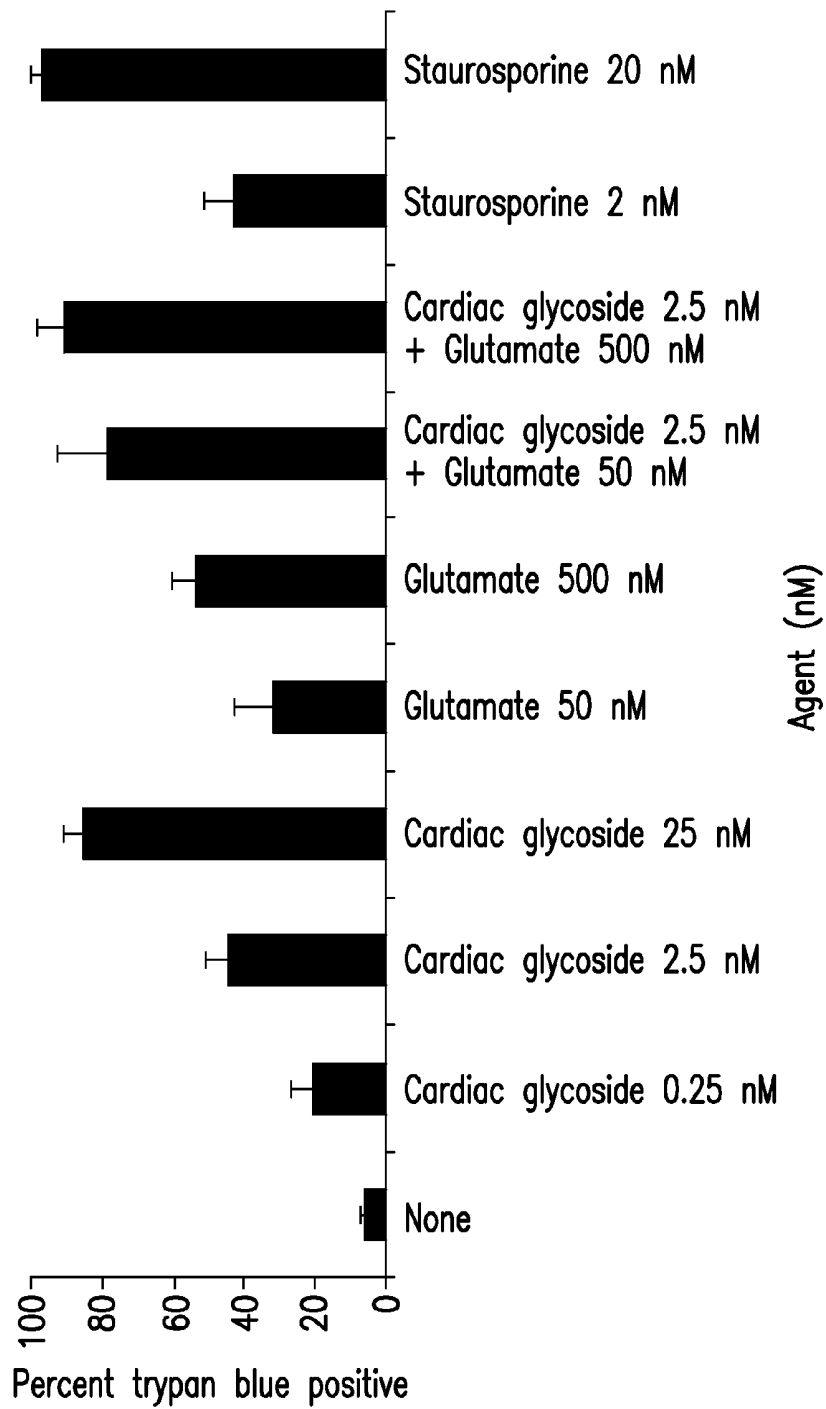

FIG. 10A

METHODS FOR RENAL DENERVATION**CROSS-REFERENCE TO RELATED APPLICATIONS**

This application claims the benefit of U.S. provisional application Ser. No. 61/336,838, filed Jan. 26, 2010, which is incorporated by reference.

BACKGROUND

A blood vessel or other bodily passage may be used to access parts of the body to deliver an agent to a target site in the wall of the vessels. For example, the renal arteries may be used as access pathways to deliver a therapeutic agent to the renal nerves, which run within the wall of the renal arteries. However, it may be difficult to deliver therapeutic agents with sufficient precision to the renal nerves. One approach is to "flood" the entire region about the circumference of the renal artery using the agent. This approach uses more of the agent than is necessary and may be toxic to the patient or surrounding tissues. Moreover, the toxicity concerns can also significantly limit the selection of particular therapeutic agents to kill nerves and the ability to provide effective treatment.

What is needed is a way of locally delivering the amount of an agent needed to effect a desired therapeutic response while reducing injury or harm to surrounding tissue. What is also needed is a way of delivering an agent to a target site within the wall of a blood vessel with increased precision and a way of removing or neutralizing excess amount of agents to reduce potential toxicity effects or vascular trauma.

Nerve denervation may be used to manage hypertension, congestive heart failure, endstage renal disease, and other conditions. Radio frequency (RF) ablation of the renal nerves has been practiced and often lacks fine control, and may cause unintended damage to neighboring tissue such as the endothelium lining blood vessels and smooth muscles that constitute blood vessel walls, resulting in vessel injury or occlusion.

What is needed are methods, devices, and agents for renal denervation which offer greater control over the denervation process than RF ablation or bolus injection, and the appropriate chemistry for controlled delivery and subsequent neutralization to reduce vessel occlusion, spasm, or other tissue damage.

SUMMARY

A method for killing targeted nerve cells in a mammal is described. The method includes delivering a potentiating agent locally to the nerve cells in an amount sufficient to potentiate the toxicity effects of an excitatory signal induced by a stimulant. The method also includes delivering a stimulant locally to the nerve cells in an amount sufficient to overstimulate the nerve cells to promote apoptosis of the nerve cells.

BRIEF DESCRIPTION OF THE DRAWINGS

FIG. 1A shows a front view of an abdominal aorta, a renal artery, renal nerves, and a kidney. FIG. 1B shows a cross-sectional view of a renal artery RA and renal nerves RN.

FIGS. 2A-2H show various embodiments of a delivery device.

FIGS. 3A-3G show various embodiments of a delivery device.

FIG. 4A shows a delivery device with a radioopaque marker. FIG. 4B shows a delivery device with depth markings

FIG. 4C shows a delivery device with an ultrasound transducer. FIG. 4D shows a delivery device with an ultrasound device. FIG. 4E shows a delivery device with a visualization device. FIG. 4F shows a delivery device with a depth control.

FIG. 5A shows a delivery device with flush ports. FIG. 5B shows a delivery device with dual balloons.

FIG. 6 shows a delivery system with a closed-feedback loop.

FIG. 7A shows a drug-eluting stent. FIG. 7B shows a time-release agent.

FIGS. 8A-8I show one embodiment of a method for using delivery device 100.

FIGS. 9A-9F show one embodiment of a method for using delivery device 1000.

FIG. 10A shows the amount of cell death caused by several of agents for a fixed amount of time.

FIG. 10B shows the amount of cell death caused by several agents versus time.

DETAILED DESCRIPTION

Methods, apparatuses, agents, and methods of delivery to provide temporary and permanent nerve blockage are described, to denerve the nervous system at specific sites and kill nerve cells to treat disease. Delivery systems and agents are described that provide site-specific treatment and control so that the controlling effects are localized and can be adjusted over time to interrupt or modulate the neural response and up or down regulate organ function. These agents are also formulated in such a way that they target or have an affinity for neural matter. Agents may also be delivered in a time-dependent release configuration that focuses treatment in a sustained manner on the desired neural matter while reducing negative effects on the surrounding tissue and related function, and protecting the blood vessel linings and surrounding tissues. Agents may also be delivered in combination or in sequence to provide enhanced agent bioavailability or bioactivity on targeted neural matter. Some neural modulation agents will have greater effect when delivered by methods that use mechanical, thermal, electric, magnetic, electromagnetic, cryogenic, or other energy forms to provide greater energy input, bioavailability, permeation, thermal, or chemical activity.

Various agents, chemicals, proteins and toxins have been used to provide temporary nerve blockage. Some of these agents include site 1 sodium channel blockers such as tetrodotoxin (TTX), saxitoxin (STX), decarbamoyl saxitoxin, vanilloids, and neosaxitoxin are used as local anesthetic formulations. Other agents such as lidocaine may be used as temporary nerve blockage agents, whereas conotoxins may also provide temporary nerve blockade. Other agents not known to provide nerve blockade are inotropic drugs such as cardiac glycosides, which have been used to treat congestive heart failure and arrhythmias, and more recently the hoi-amides have been identified to display inotropic properties. These agents are useful to achieve temporary nerve blockage, and in excess or in combination with inotropic agents, achieve long-term nerve blockade and potentiate nerve cell damage. Devices, agents and/or control methods are required to achieve permanent nerve blockade, denervation and/or neuromodulation to control bodily functions such as heart rate, hypertension, metabolic function, pain, arthritis, and the like. In addition, compounds or agents are needed that can permanently impair the function of nerve cells or specifically kill nerve cells and induce apoptosis, thus affecting the neural conduction pathways. Examples of agents are neurotoxins such as tetrodotoxin, serotoxin, ω -conotoxin; nerve agents

such as organophosphates, sarin, and others; antagonist antibodies against nerve growth hormones such as nerve growth factor (NGF), the prototypical member of the neurotrophin family; excitatory amino acids such as glutamate and domoic acid in excess or in combination with inotropic drugs. Excess concentrations of or combinations of more than one channel blocker such as lithium, carbamazepine, and verapamil can be used to promote nerve cell death.

Devices to deliver site-specific denervation agents require precise control of target location, tissue depth and location of neural matter. Such methods and devices may include catheters integrated with hollow injection ports or solid protrusions coated with agents and positioning structures such as inflatable balloons or self-expanding, spring-like structures employing standard catheter-based delivery and deployment methods used in minimally-invasive interventional procedures. In one method, mechanically expanding, self expanding devices, or braided structures formed from materials such as spring steel, nickel titanium or the like, can be placed at the desired site and activated or released in position to allow delivery of agents in predetermined patterns at discrete, non-contiguous sites along the arterial walls at specific depths from the luminal surface where neural matter is resident or where neural signal pathways are located. Such expanding device may allow for perfusion during treatment and may also be utilized to provide a stop or indexing mechanism to provide the user with a predetermined length of treatment from the aortic ostium.

The devices may also be balloons with solid protrusions to perfuse or inject agents into tissue or the wall of a vessel, or tube and syringe delivery methods. A braided structure may be used to anchor and assist in fixing a delivery catheter in a blood vessel such as the renal artery and deliver agents to one or more sites along the artery substantially simultaneously. The depth, linear spacing, and circumferential spacing of the sites for delivery is important to achieve the desired therapeutic effect while preserving vessel structure (endothelial cells, intima, and media) and function while reducing injury to the delicate vessel lining caused by the application of thermal, RF, or other forms of energy. Additionally, the braided structure may be constructed from materials that conform to the vessels at low expansion pressures to position the protrusions for agent delivery while reducing endothelial denudation. The braided structure may also include features for non-obstructive function (blood flow perfusion in the case of renal arteries, or bile secretion in the liver) during denervation.

Other delivery systems may include balloons and implantable systems made from biodegradable or coated non-biodegradable devices such as stents with protruding structures (solid protrusions or tubes) to deliver nerve denervating drugs or molecules that affect neural blockade and/or control nerve signaling while simultaneously treating atherosclerotic disease and the like. Ultrasound or other forms of mechanical agitation can be added to delivery systems to further aid and enhance agent delivery, diffusion and activity into the adventitia.

Other delivery methods may include localized treatment packaging the agents in a delivery medium that can regulate the delivery rate of agents or has an impact on the agent's half-life, while reducing impact to surrounding tissue. Such configurations may include time-release microspheres from biodegradable polymers or hydrogels and fluids that have a specific decay rates and delivery profiles. The potential for nerve fiber regeneration may also be addressed by time-release systems that can continue to kill or block nerve fibers that regenerate over time.

In order to more precisely locate target neural matter, various diagnostic devices may be used in combination with delivery systems to deliver therapy. Such imaging modalities include computed tomography (CT), magnetic-resonance imaging (MRI), fluoroscopy, or ultrasound. Ultrasound may be external or internally guided, and may use various agents such as ultrasound contrast or ultrasound microbubble agents to aid in imaging neural matter, their location and sites for denervation. Ultrasound can measure both vessel wall thickness and placement of delivery devices to ensure accurate delivery. Unlike angiography, ultrasound can also image plaque and help determine the depth of penetration needed to reach the neural matter. For example, in healthy arteries, the neurons that are present mostly in the adventitial regions of the vessel wall are located about 2-3 millimeters from the inner lumen of the blood vessel. When diseased, this distance increases by the thickness of plaque. Atherosclerotic plaque is often unevenly distributed along the circumference and length of the vessel. Ultrasound guided imaging may help locate the target location for denervation.

Electroanatomical mapping and MRI methods may also be used to identify the target location and deliver agents. In electroanatomical mapping, a mapping transducer in conjunction with an external electromagnetic field is used to map the electrical conduction pathways and neuron signal activity surrounding blood vessels and tissue. External (coil magnets) and internal (catheter-based coils) MRI imaging methods may also be used to map the neural matter and neural signal activity.

Another aspect of delivery of these agents is to reduce detrimental effects to surrounding tissue and organs. The delivery systems and methods described may include a neutralizer flush system to inactivate any agent that gets beyond the desired delivery site or any agent that does not bind target neurons within the target site. To provide this control and neutralizer function, the delivery systems may include dual isolation balloons where agent is delivered between balloons or systems that aspirate or neutralize any excess material or fluids during or after agent delivery. Polymer delivery systems may also incorporate materials to deactivate or destroy residual agents in a predetermined manner or time using coatings such as oxidizers or the like for programmed deactivation or destruction. Alternatively, delivery agents may be formulated in a time-release material that when deployed, the unbound agent is flushed by the kidneys.

FIG. 1A shows a front view of an abdominal aorta AA, a renal artery RA, renal nerves RN, and a kidney K. The renal nerves run lengthwise within the wall of the renal artery. FIG. 1B shows a cross-sectional view of a renal artery RA and renal nerves RN.

Various delivery devices are described for targeted delivery of an agent locally to the renal nerves. The delivery devices are positioned in the renal artery and penetrate into the walls of the renal artery to deliver the agent to the renal nerves. The delivery devices may be used to deliver the agent according to three parameters:

(1) Longitudinal position. The renal nerves run lengthwise along the renal artery. Instead of delivering an agent to the nerves at just one longitudinal position, the delivery devices described may be used to deliver an agent to the nerves at multiple discrete (non-contiguous) longitudinal positions along a length of the renal artery.

(2) Radial position. The renal nerves are located at varying radial positions relative to a circumference of the renal artery. Instead of delivering agents to just one radial position, the delivery devices described may be used to simultaneously deliver agents to multiple radial positions in the renal artery.

(3) Depth. The renal nerves are located at varying depths relative to an inner wall of the renal artery. Instead of delivering agents to a fixed depth or distance, the delivery devices described may be used to deliver agents to a range of desired depths or distances. The desired depths may vary along the longitudinal axis of the delivery device to account for the anatomical changes along the length of the renal artery.

The delivery devices described are capable of delivering the agent at multiple points that are discrete and non-contiguous along the length of the renal nerves, effectively increasing the amount of the renal nerves that are treated or exposed to the agent. The delivery devices described also allow for delivering small amounts of the agent to be used, by delivering the agent in a more targeted and precise manner.

FIG. 2A shows one embodiment of a delivery device **100**. Delivery device **100** includes a catheter **110** and a delivery tube **120** slidably coupled within catheter **110**. Delivery tube **120** includes a distal end **124** with a delivery point **126**. Delivery tube **120** may include a delivery lumen **125**. Alternatively, delivery tube **120** may be solid instead of hollow.

Delivery tube **120** is outwardly biased from a longitudinal axis of catheter **110**. Delivery tube **120** may be made of a shape-memory and super-elastic alloy such as nickel titanium, stainless steel, or other suitable materials of sufficient strength and toughness to achieve a desired depth of penetration. Delivery tube **120** may be preshaped to a desired three-dimensional configuration, using shape-memory or super-elastic properties of nickel-titanium or spring properties of steels or other alloys used to make springs, so that once the catheter is retracted, delivery tube **120** makes contact with and penetrates into wall **W**. Delivery point **126** may be sharp. Delivery lumen **125** may have an inner surface that is coated or treated with polyethylene or other suitable material to reduce the loss or degradation of agents from adhesion inside delivery lumen **125** while delivering the agent

Delivery tube **120** is delivered retracted inside catheter **110**, with delivery point **126** unexposed. Delivery tube **120** is positioned in a vessel **V** at the longitudinal position of a target site **T**. Catheter **110** may also be rotated to position delivery point **126** at a radial position of target site **T**. Delivery tube **120** is then extended from catheter **110** to expose delivery point **126** and penetrate into wall **W**. Delivery tube **120** is extended until delivery point **126** is positioned at a depth of target site **T**. Delivery tube **120** then delivers an agent through delivery lumen **125** to target site **T**. Alternatively, delivery point **126** may be treated or coated with an agent which is capable of being absorbed by target site **T**.

FIG. 2B shows another embodiment of a delivery device **200**. Delivery device **200** is similar to delivery device **100**, but includes a plurality of delivery tubes **120**. Delivery tubes **120** may each be independently extended and retracted from catheter **110**. Delivery device **200** allows multiple target sites **T** at the same longitudinal position to be treated at the same time.

FIGS. 2C-2D show another embodiment of a delivery device **300**. FIG. 2C shows a side view of delivery device **300**. FIG. 2D shows an end view of delivery device **300**. Delivery device **300** includes a catheter **310** with a plurality of ports **316**. Ports **316** are formed at the same angle relative to a longitudinal axis of catheter **310**. Delivery device **300** also includes a plurality of delivery tubes **320** slidably coupled within catheter **310**. Delivery tubes **320** may be evenly or irregularly spaced. Delivery tubes **320** each include a distal end **324** with a delivery point **326**. Delivery tubes **320** may each include a delivery lumen **325**. Alternatively, one or more delivery tubes **320** may be solid instead of hollow.

Delivery tubes **320** are outwardly biased from a longitudinal axis of catheter **310**. Delivery tubes **320** may be made of

a shape-memory alloy such as nickel titanium, or other suitable material. Delivery tubes **320** may be preshaped to a desired three-dimensional configuration, using shape-memory or super-elastic properties of nickel-titanium or spring properties of steels or other alloys used to make springs, so that once the catheter is retracted, delivery tubes **320** make contact with and penetrate into wall **W**. Delivery points **326** may be sharp. Delivery lumens **325** may have inner surfaces that are coated or treated with polyethylene or other suitable material to reduce the loss or degradation of agents from adhesion inside delivery lumens **325**.

Delivery tubes **320** are delivered retracted inside catheter **310**, with delivery points **326** unexposed. Delivery tubes **320** are positioned in a vessel **V** at the longitudinal position of a target site **T**. Catheter **310** may also be rotated to position delivery points **326** at a radial position of target site **T**. Delivery tubes **320** are then extended from catheter **310** through ports **316** to expose delivery points **326** and penetrate into wall **W**. Delivery tubes **320** may be extended until delivery points **326** are positioned at a depth of target site **T**. Delivery tubes **320** then deliver an agent through delivery lumens **325** to target site **T**. Alternatively, delivery points **326** may be treated or coated with an agent which is capable of being absorbed by target site **T**. Delivery device **300** allows a longer target site **T** at a similar radial position to be treated at the same time.

FIGS. 2E-2F show another embodiment of a delivery device **400**. FIG. 2E shows a side view of delivery device **400**. FIG. 2F shows an end view of delivery device **400**. Delivery device **400** is similar to delivery device **300**, but includes a plurality of ports **316** that are formed at different angles relative to a longitudinal axis of catheter **310**. Delivery tubes **320** thus extend at different angles from catheter **310**. Delivery device **400** allows longer target sites **T** at multiple radial positions to be treated at the same time.

FIG. 2G shows another embodiment of a delivery device **500**. Delivery device **500** includes a catheter **510** with a plurality of ports **516**, with each port **516** formed on a separate catheter section **518**. Each catheter section **518** may be slidably disposed within the catheter section **518** before it. Delivery device **500** also includes a plurality of delivery tubes **520** slidably coupled within catheter **510**. Delivery tubes **520** each include a distal end **524** with a delivery point **526**. Delivery tubes **520** may each include a delivery lumen **525**. Alternatively, one or more delivery tube **520** may be solid instead of hollow.

Delivery tubes **520** are outwardly biased from a longitudinal axis of catheter **510**. Delivery tubes **520** may be made of a shape-memory alloy such as nickel titanium, or other suitable material. Delivery tubes **520** may be preshaped to a desired three-dimensional configuration, using shape-memory or super-elastic properties of nickel-titanium or spring properties of steels or other alloys used to make springs, so that once the catheter is retracted, delivery tubes **520** make contact with and penetrate into wall **W**. Delivery points **526** may be sharp. Delivery lumens **525** may have inner surfaces that are coated or treated with polyethylene or other suitable material to reduce the loss or degradation of agents from adhesion inside delivery lumens **525**.

Delivery tubes **520** are delivered retracted inside catheter **510**, with delivery points **526** unexposed. Each catheter section **518** may be independently extended and retracted to position delivery tubes **520** at the longitudinal positions of target sites **T**. Each catheter section **518** may also be independently rotated to position delivery points **526** at the radial positions of target sites **T**. Delivery tubes **520** are then extended from catheter sections **518** through ports **516** to

expose delivery points **526** and penetrate into wall W. Delivery tubes **520** may each be independently extended until delivery points **526** are positioned at the depths of target sites T. Delivery tubes **520** then deliver an agent through delivery lumens **525** to target sites T. Alternatively, delivery points **526** may be treated or coated with an agent which is capable of being absorbed by target sites T. Delivery device **500** allows multiple target sites with different longitudinal positions, radial positions, and depths to be treated at the same time.

FIG. 2H shows another embodiment of a delivery device **600**. Delivery device **600** includes a catheter **610** with a coil **620** having along its length one or more delivery points **626**. Coil **620** also includes a delivery lumen **625**.

Coil **620** is self-expanding. Coil **620** may be made of a shape-memory alloy such as nickel titanium, or any other suitable material. Coil **620** may be preshaped to a desired three-dimensional configuration, using shape-memory or super-elastic properties of nickel-titanium or spring properties of steels or other alloys used to make springs, so that once the catheter is retracted, coil **620** expands and makes contact with and delivery points **626** penetrate into wall W. Delivery points **626** may be sharp. Delivery lumen **625** may have an inner surface that is coated or treated with polyethylene or other suitable material to reduce the loss or degradation of agents from adhesion inside delivery lumen **625**.

Coil **620** is delivered in an unexpanded configuration inside catheter **610**, with delivery points **626** unexposed. Coil **620** is positioned in a vessel V at the longitudinal position of target sites T. Catheter **610** is then pulled back to allow coil **620** to open and expose delivery points **626** to penetrate into wall W. Coil **620** then delivers an agent through delivery lumen **625** to target sites T. Alternatively, delivery points **626** may be treated or coated with an agent which is capable of being absorbed by target sites T.

FIG. 3A shows another embodiment of a delivery device **700**. Delivery device **700** is similar to delivery device **100**, but also includes a balloon **130** coupled to a distal end **114** of catheter **110**.

Balloon **130** may have a port **132** through which delivery tube **120** can pass. Balloon **130** may be inflated and deflated through an inflation lumen **135**. When inflated, balloon **130** may anchor distal end **114** of catheter **110** within vessel V.

FIG. 3B shows another embodiment of a delivery device **800**. Delivery device **800** is similar to delivery device **200**, but also includes a balloon **130** coupled to a distal end **114** of catheter **110**.

FIG. 3C shows another embodiment of a delivery device **900**. Delivery device **900** is similar to delivery device **400**, but includes a balloon **330** adjacent to each port **316**.

FIG. 3D shows another embodiment of a delivery device **1000**. Delivery device **1000** includes a catheter **1010** with a balloon **1030**. A plurality of delivery points **1026** is coupled to the surface of balloon **1030**. Catheter **1010** includes a delivery lumen **1025** in fluid communication with the delivery points **1026**. Catheter **1010** also includes an inflation lumen **1035** coupled to the balloon.

Delivery points **1026** may be sharp. Delivery lumen **1025** may be coated or treated with polyethylene or other suitable material to reduce the loss of agents from adhesion inside delivery lumen **1025**.

Balloon **1030** is delivered in a deflated configuration inside catheter **1010**, with delivery points **1026** unexposed. Balloon **1030** is positioned in a vessel V at the longitudinal position of target sites T. Catheter **1010** is then pulled back and balloon **1030** inflated to expose delivery points **1026** to penetrate into wall W. Delivery points **1026** then deliver an agent to target sites T.

FIG. 3E shows one embodiment of a delivery device **1100**. Delivery device **1100** includes a catheter **1110** and a plurality of delivery tubes **1120** slidably coupled within catheter **1110**. Delivery tubes **1120** each include a distal end **1124** with a delivery point **1126**. Delivery tubes **1120** may each include a delivery lumen **1125**. Alternatively, one or more delivery tubes **1120** may be solid instead of hollow.

Delivery device **1100** also includes a balloon **1130** slidably coupled within catheter **1110** at a center of delivery tubes **1120**. Balloon **1130** is not coupled to delivery tubes **1120**. Balloon **1130** may be inflated and deflated through an inflation lumen **1135**. When inflated, balloon **1130** may anchor distal end **1114** of catheter **1110** within vessel V.

Delivery tubes **1120** may be made of a shape-memory and super-elastic alloy such as nickel titanium, stainless steel, or other suitable materials of sufficient strength and toughness to achieve a desired depth of penetration. Delivery points **1126** may be sharp. Delivery lumens **1125** may have inner surfaces that are coated or treated with polyethylene or other suitable material to reduce the loss or degradation of agents from adhesion inside delivery lumens **1125**.

Delivery tubes **1120** are delivered retracted inside catheter **1110**, with delivery points **1126** unexposed. Delivery tubes **1120** are positioned in a vessel V at the longitudinal position of a target site T. Catheter **1110** may also be rotated to position delivery points **1126** at a radial position of target site T. Delivery tubes **1120** are then extended from catheter **1110** to expose delivery points **1126**. Balloon **1130** is then extended from catheter **1110** distally to delivery tubes **1120**, and inflated through inflation lumen **1135** to urge delivery points **1126** toward wall W. Delivery tubes **1120** may continue to be extended to further urge delivery toward wall W and into wall W. Delivery tubes **1120** are extended until delivery points **1126** are positioned at depths of target sites T. Delivery tubes **1120** then deliver an agent through delivery lumens **1125** to target sites T. Alternatively, delivery points **1126** may be treated or coated with an agent which is capable of being absorbed by target sites T.

FIG. 3F shows one embodiment of a delivery device **1200**. Delivery device **1200** is similar to delivery device **1110**, but also includes a plurality of delivery tubes **1120** both proximally and distally to balloon **1130**.

FIG. 3G shows one embodiment of a delivery device **1300**. Delivery device **1300** includes a catheter **1310** and a plurality of delivery tubes **1320** slidably coupled within catheter **1310**. Delivery tubes **1320** each include a distal end **1324** with a delivery point **1326**. Delivery tubes **1320** may each include a delivery lumen **1325**. Alternatively, one or more delivery tubes **1320** may be solid instead of hollow.

Delivery device **1300** also includes a positioning device **1330** slidably coupled within catheter **1310**. Positioning device **1330** may be a self-expanding structure with an open mesh-like architecture.

Delivery tubes **1320** may be made of a shape-memory and super-elastic alloy such as nickel titanium, stainless steel, or other suitable materials of sufficient strength and toughness to achieve a desired depth of penetration. Delivery points **1326** may be sharp. Delivery lumens **1325** may have inner surfaces that are coated or treated with polyethylene or other suitable material to reduce the loss or degradation of agents from adhesion inside delivery lumens **1325**.

Delivery tubes **1320** are delivered retracted inside catheter **1310**, with delivery points **1326** unexposed. Delivery tubes **1320** are positioned in a vessel V at the longitudinal position of a target site T. Catheter **1310** may also be rotated to position delivery points **1326** at a radial position of target site T. Positioning structure **1330** is delivered in an unexpanded state

inside catheter **1310**. Positioning structure **1330** is extended from catheter **1310** and allowed to expand, anchoring distal end **1314** of catheter **1310** within vessel V. Delivery tubes **1320** are then extended from catheter **1310** to expose delivery points **1326** and pass through positioning structure **1330** to penetrate into wall W. Delivery tubes **1320** are extended until delivery points **1326** are positioned at depths of target sites T. Delivery tubes **1320** then deliver an agent through delivery lumens **1325** to target sites T. Alternatively, delivery points **1326** may be treated or coated with an agent which is capable of being absorbed by target sites T.

Positioning device **1330** and delivery points **1326** may be retracted, advanced further and repositioned inside the artery for additional delivery of agent along several locations along the renal artery.

FIG. 4A shows delivery device **100** with a radioopaque marker **140** coupled to distal end **114** of catheter **110**. Radioopaque marker **140** acts as an aid in positioning delivery tube **120**. Radioopaque marker **140** may be made of gold, platinum, platinum iridium alloys, or other suitable material.

FIG. 4B shows delivery device **100** with radioopaque depth markings **150** on delivery tube **120**. Depth markings **150** aid in measuring the depth of penetration while guiding delivery point **126** of delivery tube **120** to target site T. Delivery tube **120** may also house a strain gage or other suitable force transducer or sensor to monitor contact with wall W and depth of penetration.

FIG. 4C shows delivery device **100** with an ultrasound transducer **160** coupled to distal end **114** of catheter **110**. Ultrasound transducer **160** allows imaging of the location and monitoring of the location and depth of delivery tube **120**, as well as the volume of agent delivered. Ultrasound-based imaging of the target location may be enhanced by the use of contrast media (contrast-enhanced ultrasound) such as gas-filled microbubbles that are administered intravenously to the systemic circulation prior to the procedure. Further, these gas-filled microbubbles may also be targeted with ligands that bind certain molecular markers that are expressed by the area of imaging interest. Contrast media is injected systemically in a small bolus and detection of bound microbubbles show the area of interest or identify particular cells in the area of interest.

FIG. 4D shows delivery device **100** with an ultrasound device **170** coupled to a proximal end **122** of delivery tube **120**. Ultrasound device **170** transmits ultrasound energy through delivery tube **120** to delivery point **126**, which may enhance the bioavailability of the agent.

FIG. 4E shows delivery device **100** with a visualization device **180** coupled to distal end **114** of catheter **110**. Visualization device **180** allows direct visualization of delivery tube **120** and wall W. Visualization device **180** may be electromagnetic transducer, magnetic-resonance imaging (MRI) transducer, angioscope, camera, or other suitable device.

Visualization device **180** may be an electromagnetic transducer, including one or more electrode pairs, coupled to distal end **114** of catheter **110**. The electromagnetic transducer works in conjunction with a low-level magnetic field (5×10^{-6} to 5×10^{-5} Tesla) generated by electromagnetic coils placed on the operating table beneath the patient. The electromagnetic transducer can be moved along the vessel to record and map the electrical activity along the entire surface of the renal artery. These electrical signals map the neuron activity or electrical conduction pathways of the peripheral nervous system surrounding the renal arteries, and aid in identifying the target location for delivering the agent.

Visualization device **180** may be a magnetic-resonance imaging (MRI) transducer coupled to distal end **114** of cath-

eter **110**. The MRI transducer works in conjunction with a specific contrast agent delivered, as a bolus, to the patient to assist in imaging the electrical conduction of the peripheral nervous system surrounding the renal arteries, and to help in identifying the target site for denervation.

FIG. 4F shows delivery device **100** with a depth control **190** coupled to proximal end **112** of catheter **110** and proximal end **122** of delivery tube **120**. Depth control **190** includes marks which indicate how far delivery tube **120** has been extended.

Delivery device **100** may include a separate luminal port in the catheter to inject radioopaque contrast agents to image the location of the catheter and the target site using X-ray fluoroscopy or angiography during the procedure.

FIG. 5A shows delivery device **100** having a catheter **110** with flush ports **117**. Flush ports **117** may introduce a neutralizing substance into vessel V which neutralizes at least some of the agent delivered by delivery tube **120** which leaks back into vessel V.

FIG. 5B shows one embodiment of a delivery device **1400**. Delivery device **1400** includes a catheter **1410** with a delivery tube port **1416** and an aspiration port **1417**. Delivery device **1400** also includes a delivery tube **1420** slidably coupled within catheter **1410**. Delivery tube **1420** includes a distal end **1424** with a delivery point **1426**. Delivery tube **1420** may also include a delivery lumen **1425**. Alternatively, delivery tube **1420** may be solid instead of hollow. Delivery device **1400** also includes balloons **1430** coupled to catheter **1410** both proximally and distally to delivery tube port **1416** and aspiration port **1417**. Catheter **1410** includes perfusion ports **1419** distal and proximal to balloons **1430**.

Delivery tube **1420** is outwardly biased from a longitudinal axis of catheter **1410**. Delivery tube **1420** may be made of a shape-memory alloy such as nickel titanium, or other suitable material. Delivery tube **1420** may be preshaped to a desired three-dimensional configuration, using shape-memory or super-elastic properties of nickel-titanium or spring properties of steels or other alloys used to make springs, so that once the catheter is retracted, delivery tube **1420** makes contact with and penetrates into wall W. Delivery point **1426** may be sharp. Delivery lumen **1425** may have an inner surface that is coated or treated with polyethylene or other suitable material to reduce the loss or degradation of agents from adhesion inside delivery lumen **1425**.

Delivery tube **1420** is delivered retracted inside catheter **1410**, with delivery point **1426** unexposed. Delivery tube **1420** is positioned in a vessel V at the longitudinal position of a target site T. Catheter **1410** may also be rotated to position delivery point **1426** at a radial position of target site T. Balloons **1430** are inflated to anchor the catheter in vessel V and to isolate a portion of vessel V. Delivery tube **1420** is then extended from catheter **1410** through delivery tube port **1416** to expose delivery point **1426** and penetrate into wall W. Delivery tube **1420** is extended until delivery point **1426** is positioned at a depth of target site T. Delivery tube **1420** then delivers an agent through delivery lumen **1425** to target site T. Alternatively, delivery point **1426** may be treated or coated with an agent which is capable of being absorbed by target site T. Excess agent which returns into vessel V is isolated by balloons **1430** and may be vented out through aspiration port **1417**. Perfusion ports **1419** allow fluid flow through vessel V to continue even when balloons **1430** are inflated.

FIG. 6 shows one embodiment of a delivery device **1500**. Delivery device **1500** includes a sensor **1510** coupled to a pump **1520** and a catheter **1530**. Sensor **1510** is configured to measure a physiological parameter. Pump **1520** includes control software and an agent. Catheter **1530** is implanted in a suitable location within the body. Pump **1520** receives data

from sensor **1510**, and responds by using control software to determine an amount of the agent to deliver through catheter **1530**. For example, sensor **1510** may be used to measure blood pressure, which pump **1520** uses to determine an amount of a denervating agent to deliver through the catheter **1530**, which is implanted to deliver the agent to the renal nerves. Delivery device **1500** thus uses a closed feedback loop to control a physiological parameter such as blood pressure.

FIG. **7A** shows a drug-eluting stent **1600** which may be implanted in a renal artery. FIG. **7B** shows a polymer-encapsulated time-release agent **1700**.

FIGS. **8A-8I** show one embodiment of a method of using a delivery device **100**.

FIG. **8A** shows mapping of vessel **V** and nerves using a mapping catheter **C**. Mapping catheter **C** is introduced into vessel **V** and used to locate and map the nerves surrounding vessel **V**. In this example, vessel **V** is a renal artery and the nerves are renal nerves. Alternatively, vessel **V** may be a renal vein or other vessel which provides access to the renal nerves. Mapping catheter **C** may be an electrical mapping catheter, an ultrasound catheter, a magnetic resonance imaging (MRI) catheter, or other suitable catheter. An electrical mapping catheter may be cardiac mapping catheter adapted for use in the renal artery and renal nerves. An ultrasound catheter may be used with contrast agents such as paramagnetic (e.g., gadolinium, manganese) and superparamagnetic (e.g., iron oxide) contrast agents, in the form of nanoparticles or other suitable form. An MRI catheter may be used with fluorescent nanoparticles, fluorescent microspheres and other agents to enhance imaging.

FIG. **8B** shows introducing delivery device **100** into vessel **V**. Catheter **110** may be moved along vessel **V** to place delivery point **126** of delivery tube **120** at the longitudinal position of target site **T**. Catheter **110** is capable of being placed in the proximal third of the renal artery beginning at the aorto-ostial junction of the aorta and renal artery. Catheter **110** may be placed with the assistance of radioopaque marker **140**.

FIG. **8C** shows rotating catheter **110** in vessel **V** to place delivery tube **120** at the radial position of target site **T**.

FIG. **8D** shows extending delivery tube **120** from catheter **110** to penetrate into wall **W** of vessel **V**. Delivery tube **120** is extended until delivery point **126** is placed at the depth of target site **T**. Delivery point **126** may be placed at target site **T** with the assistance of depth markings **150**, ultrasound transducer **160**, or other suitable features and devices. Depth control **190** may be used to control delivery tube **120** and delivery point **126**. In renal arteries, the depth for healthy vessels may have a range of 1-10 mm, with a typical range of 2-3 mm. For diseased vessels, such as those lined with atherosclerotic plaque, the depth may have a range of 3-15 mm, with a typical range of 4-7 mm.

FIG. **8E** shows delivering a preparatory agent to target site **T** using delivery tube **120**. Preparatory agent may be an anesthetic, vasoconstrictor, vasodilator, neurotropic agent conjugated to a traceable marker, steroid, or other suitable agent. Preparatory agent serves to anesthetize, reduce uptake of delivered agents by vessel **V**, and other purposes. The traceable marker may be a lipophilic dye or fluorophore (e.g., Nile red, long-chain carbocyanines), a radioisotope (e.g., thallium ²⁰¹Tl, technetium ^{99m}Tc, gallium ⁶⁷Ga, lithium ⁶Li, lithium ⁷Li), metallic nanoparticles (e.g., gadolinium, iron oxide, manganese), an enzyme, contrast agents (e.g., gadodiamide), and/or antibodies (e.g., antibodies against myelin oligodendrocyte glycoprotein, axonin-1, neuronal cell adhesion molecule, neuroglial cell adhesion molecule).

FIG. **8F** shows delivering a priming agent to target site **T** using delivery tube **120**. Delivering a priming agent may be performed at a controlled rate. A priming agent may be used as an initial signal to activate or inactivate nerve intracellular signaling, nerve cell action potential, or nerve cell membrane repolarization.

Priming agent may be an inotropic drug (e.g., cardiac glycoside, hoiamides), channel blocker (e.g., conotoxins, amlodipine, diltiazem, verapamil), excitatory amino acid (e.g., glutamate, domoic acid), beta-blocker (e.g., propranolol), bipartite fusion construct, pro-apoptotic factor (e.g., staurosporine, tumor necrosis factor (TNF), antibody against nerve growth factor receptor p75, glucocorticoid), neurotropic agent conjugated to a neuroactive agent, or anti-manic agent (e.g., lithium).

Neurotropic agents may be an antibody against UCHL1, myelin oligodendrocyte glycoprotein, axonin-1, neuronal cell adhesion molecule, neuroglial cell adhesion molecule; nerve growth factor, reovirus $\sigma 1$ protein, rabies spike glycoprotein, Theiler's murine encephalomyelitis virus (TMEV), or other suitable agents used to bind to the surface of nerve cells in a specific manner.

Priming agent may also be a toxin or toxic peptide (e.g., conotoxin, tetrodotoxin, saxitoxin), alcohol (e.g., ethanol), an enzyme (e.g., eosinophil cationic protein/RNase 3), phenol, or an anti-convulsant (carbamazepine).

Priming agent may also be a neurotropic agent (e.g., ciliary neurotropic factor (CNTF), brain derived neurotropic factor (BDNF), glial derived nexin (GDN)).

Priming agent may also be batrachotoxin, neosaxitoxin, gonyautoxins, aurotoxin, agitoxin, charybdotoxin, margaoxin, slotoxin, scyllatoxin, hefutoxin, calciseptine, taicatoxin, calcicludeine, PhTx3, amphetamine, methamphetamine, or MDMA.

FIG. **8G** shows an optional step of enhancing delivery of an agent using ultrasound device **170**. Alternatively, enhancing delivery may be performed with mechanical, ultrasonic, thermal, and/or other energy means.

FIG. **8H** shows an optional step of delivering a neutralizing agent using flush ports **117** in catheter **110**. Neutralizing agent deactivates at least some of any excess agent which may escape back into vessel **V** or excess agent that remains unbound to nerve cells. Neutralizing agent may be a dilutant such as saline, a neutralizing antibody (e.g., digoxin immune Fab), an enzyme (e.g., glutamate dehydrogenase), sodium bicarbonate (to neutralize phenol), a chelating agent (e.g., EDTA, EGTA), a steroid, non-steroidal anti-inflammatory drugs (e.g., aspirin, ibuprofen, sirolimus), or other suitable agent.

FIG. **8I** shows delivering a secondary agent to target site **T** using delivery tube **120**. Secondary agent may be delivered at a controlled rate. Secondary agent may be delivered at the same time as priming agent, or at some predetermined time after priming agent. Priming agent and secondary agent may be different agents. Priming agent and secondary agent may also be the same agent, in the same or different volumes and/or concentrations. Priming agent and secondary agent may be different agents and may be linked together to form a bi-partite construct. Priming agent may also be linked to two different secondary agents to form a tri-partite construct. The function of sequential or combined delivery of priming and secondary agents is to deliver multiple stimuli to the nerve cell to promote or induce nerve cell death.

The use of a priming agent and a secondary agent may result in a synergistic effect. This synergistic effect may result in (1) smaller amounts of the agents needed than if either

agent was used by itself, (2) faster action than if either agent was used by itself, and (3) greater effectiveness than if either agent was used by itself.

Some or all of the method may be repeated as desired. For example, delivering a secondary agent may be followed by enhancing delivery and delivering a neutralizing agent. As another example, delivering a secondary agent may be followed by delivering another secondary agent.

FIGS. 9A-9F show one embodiment of a method for using delivery device 1000.

FIG. 9A shows mapping of vessel V and nerves using a mapping catheter C. Mapping catheter C is introduced into vessel V and used to locate and map the nerves surrounding vessel V. In this example, vessel V is a renal artery and the nerves are renal nerves. Alternatively, vessel V may be a renal vein or other vessel which provides access to the renal nerves. Mapping catheter C may be an electrical mapping catheter, an ultrasound catheter, a magnetic resonance imaging (MRI) catheter, or other suitable catheter.

FIG. 9B shows introducing delivery device 1000 into vessel V. Catheter 1010 may be moved along vessel V to place distal end 1014 at the longitudinal position of target sites T. Catheter 1010 is capable of being placed in the proximal third of the renal artery beginning at the aorto-ostial junction of the aorta and renal artery. Catheter 1010 may be placed with the assistance of a positioning element 1011 such as a balloon or self-expanding structure. Positioning element 1011 is coupled to catheter 1010 at a fixed or known distance from distal end 1014. Positioning element 1011 may be configured to fit at the ostium of the renal artery.

FIG. 9C shows deploying balloon 1030 from catheter 1010. Positioning element 1011 is fully expanded, and may be seated at the ostium of the renal artery, thus positioning distal end 1014 and balloon 1030 at a fixed or known distance from the ostium of the renal artery.

FIG. 9D shows rotating balloon 1030 in vessel V to place delivery points 1026 of balloon 1030 at the radial positions of target sites T.

FIG. 9E shows expanding balloon 1030 in vessel V to urge delivery points 1026 into wall W of vessel V. Delivery points 1026 are of a known length, and penetrate a known distance into wall W to reach target sites T. Delivery points 1026 may have different lengths and configurations. For example, delivery points 1026 may become have lengths that become shorter with distance from the ostium of the renal artery. As another example, delivery points 1026 may have delivery lumens 1025 that become smaller and deliver less agent with distance from the ostium of the renal artery.

Delivery points 1026 may be arranged in a predetermined configuration or pattern. The configuration or pattern of delivery points 1026 may be selected to maximize the probability they will be positioned on or near the renal nerves in the renal artery, based on distribution data for the renal nerves. Several different preconfigured patterns may be available, with selection based on results of mapping of the renal nerves. The configuration or pattern of delivery points 1026 may also be selected to be non-circumferential to reduce the effects of any swelling or stenosis. For example, the configuration or pattern may be a helical or spiral pattern, as opposed to one or more circumferential rings.

Delivery points 1026 are capable of creating noncontiguous or discrete delivery areas. Delivery points 1026 are capable of delivering very small quantities of agents. The ability to deliver very small quantities in a very focused and targeted manner allows for a greater selection of very toxic agents to be used.

FIG. 9F shows delivering an agent to target sites T. Agent may be one or more agents, delivered sequentially or substantially simultaneously.

Other methods may be used to deliver agents. For example, agents may be delivered with a drug-eluting stent. The stent may be configured to fit inside the renal artery, and may be bioabsorbable. The stent may be configured to deliver a priming agent during a first period of time, and a secondary agent during a second period of time. As another example, agents may be delivered in time-release formulations, such as encapsulated in polymers. The time-release formulations may be configured to release a priming agent during a first period of time, and a secondary agent during a second period of time. As yet another example, agents may be delivered with microbubbles having a diameter of approximately 1-10 micrometers, used in combination with focused ultrasound. These microbubbles may temporarily permeabilize the vessel wall in a localized area to permit the passage of neuroactive or neurotoxic agents through the vasculature and to the surrounding interstitial tissue near a nerve cell.

Agents may be transiently housed within or complexed with liposomes. The liposomes may contain nerve growth factor (NGF) on the outer leaflet of the liposomal membrane or may contain one or more other neurotropic agent (e.g., ciliary neurotropic factor (CNTF), brain derived neurotropic factor (BDNF), glial derived nexin (GDN)).

Glutamate or domoic acid (0.00005-700 mM) can be administered as a denervating agent singly or in combination. Excessive stimulation of neurons by glutamate initiates a cascade of ion fluxes, cellular swelling and death in nerve cells. Additionally, fibroblasts expressing human NR1a/2A or NR1a/2B NMDA receptors are hypersensitive to glutamate receptor-mediated toxicity and NR1a/2B NMDA receptors are expressed in tissues outside of the brain (kidney, adrenal cortex, pancreas, heart and others) in low amounts.

L-glutamate is the major excitatory neurotransmitter in the central nervous system and activates both ionotropic and metabotropic glutamate receptors. Glutamatergic neurotransmission is involved in most aspects of normal brain function and can be perturbed in many neuropathologic conditions. The metabotropic glutamate receptors are a family of G protein-coupled receptors that have been divided into 3 groups on the basis of sequence homology, putative signal transduction mechanisms, and pharmacologic properties. Group I includes GRM1 and GRM5 and these receptors have been shown to activate phospholipase C. Group II includes GRM2 and GRM3 while Group III includes GRM4, GRM6, GRM7 and GRM8.

Group II and III receptors are linked to the inhibition of the cyclic AMP cascade but differ in their agonist selectivities. The canonical alpha isoform of the metabotropic glutamate receptor 1 gene is a disulfide-linked homodimer whose activity is mediated by a G-protein-coupled phosphatidylinositol calcium second messenger system. GRM receptor expression is not exclusive to neurons and has been determined to be present in kidney, liver, heart, lungs, thyroid and other organs.

Cardiac glycosides are inotropic drugs that specifically inhibit Na⁺,K⁺ATPase activity. Cardiac glycoside binding to the alpha subunit of the Na⁺,K⁺ATPase induces intracellular ion flux. Extended inhibition of Na⁺,K⁺ATPase function can induce apoptosis in nerve cells. Additionally, brief exposure (5 to 10 minutes) to high concentrations of cardiac glycoside (1-10 mM) is toxic to nerve cells.

A combination of an amino acid and an inotropic drug can be administered to potentiate nerve cell blockade, sensitivity, damage or death. Exposure to cardiac glycoside (0.01-1 mM)

prior to exposure of a nerve cell to glutamate produces super-sensitivity in a nerve cell and induces glutamate excitotoxicity.

Ziconotide is a synthetic peptide derived from a toxin produced by the marine snail, *Conus magus*. Ziconotide selectively targets N-type voltage-gated calcium channels. Additionally, other members of the cysteine-rich conotoxin superfamily can be used to target nerve cells. Conotoxins and peptides derived from conotoxins (conopeptides) have also shown efficacy in clinical applications. Targeted administration of a high concentration of toxic peptide can induce nerve cell damage and death.

Hoiamide B(2) is a cyclic depsipeptide produced by marine cyanobacteria. The linear lipopeptide, hoiamide C(3) is also produced by marine cyanobacteria. Both metabolites possess the unique hoiamide structural class, characterized by an acetate extended and S-adenosyl methionine modified isoleucine, a central tri-heterocyclic core of two alpha-methylated thiazolines and one thiazole, and a highly oxygenated and methylated C-15 polyketide unit. Hoiamides have been demonstrated to induce sodium influx and suppress calcium oscillations.

Eosinophil cationic protein/RNase 3 can induce neurotoxicity, consistent with apoptosis, in a dose-dependent manner. Upon binding to the nerve cell surface, an increase in free cytosolic calcium flux, induction of caspase-3, -8, and -9 can be observed.

The bi-partite fusion construct contains (i) a neurotropic agent that has high affinity to one or more receptors on the surface of a nerve cell, and is linked by a flexible linker to (ii) a neuroactive agent that alters a nerve cell. In one example, the neurotropic agent is the β -subunit of nerve growth factor (NGF). NGF is internalized into the neurons following binding to cognate receptors located on nerve cells.

A bi-partite neurotropic fusion construct may be used to mark nerve cells and nerve bundles. The neurotropic agent can be a protein, peptide or other ligand for a receptor located on the surface of nerve cell. The neurotropic agent is linked by a hydrolysable or flexible linker (protein, PEGylated crosslinker, or other) to a traceable marker. The traceable marker can be a fluorophore, radioisotope, metallic nanoparticles, enzyme, antibody or other and can be detected by conventional methods. Binding of the neurotropic agent delivers the traceable marker to the nerve cell. The binding of the fusion construct labels the outside and inside of the nerve (upon internalization).

A bi-partite neurotropic fusion construct to generate nerve cell blockade, damage or death. The neurotropic agent can be a protein, peptide or other ligand for a receptor located on the surface of nerve cell. The neurotropic agent is linked by a hydrolysable or flexible linker (protein, PEGylated crosslinker, or other) to a neuroactive agent. The neuroactive agent can be a toxin, drug, hoiamide, antibody or other and can interrupt nerve cell homeostasis. Binding of the neurotropic agent delivers the neuroactive agent to the nerve cell. The binding of both agents potentiates the action of the neuroactive agent.

MDMA, also known as ecstasy, is an amphetamine-like stimulant known to induce apoptotic damage of serotonergic nerves.

Calcium channel blockers block voltage-gated calcium channels to decrease the electrical conductance of a nerve cell and are used as anti-epileptic drugs. Targeted administration of a high concentration of calcium channel blocker can induce nerve cell damage and death.

Potassium channel blockers block potassium channels to prolong repolarization of the nerve cell and are used as anti-

arrhythmic drugs. Targeted administration of a high concentration of potassium channel blocker can induce nerve cell damage and death.

Pro-apoptotic factors activate the caspase signaling cascade, leading to a "quiet" programmed cell death characterized by blebbing, loss of cell membrane asymmetry and attachment, cell shrinkage, nuclear fragmentation, chromatin condensation, and chromosomal DNA fragmentation. This is separate from necrosis, which is traumatic cell death that results from physical, electrical or chemical trauma and is pro-inflammatory.

EXAMPLE 1

A vasoconstrictor (antidiuretic hormone (ADH or vasopressin) or tetrahydrozoline) is first administered to vessels surrounding the target site to minimize leakage of the priming or secondary agents.

A priming agent of digoxin at a concentration of 0.0001-10 mM in a volume of 0.05-2 cc is then administered at a nerve proximal site to prime the neurons by inhibiting the transport of potassium and sodium across the nerve cell membrane and subsequently inducing an intracellular calcium flux.

Approximately 0.1-20 minutes later, a secondary agent of glutamate at a concentration of 0.1-700 mM in a volume of 0.05-2 cc is then administered at a nerve proximal site to induce neuronal excitotoxicity.

Vasoconstriction results from the increased concentration of calcium (Ca^{2+} ions) within vascular smooth muscle cells. However, the specific mechanisms for generating an increased intracellular concentration of calcium depends on the vasoconstrictor. Two common stimuli for eliciting smooth muscle contraction are circulating epinephrine and activation of the sympathetic nervous system (through release of norepinephrine) that directly innervates the muscle. These compounds interact with cell surface adrenergic receptors. Such stimuli result in a signal transduction cascade that leads to increased intracellular calcium from the sarcoplasmic reticulum (SR) through IP3 mediated calcium release, as well as enhanced calcium entry across the sarcolemma through calcium channels. The rise in intracellular calcium complexes with calmodulin, which in turn activates myosin light chain kinase. This enzyme is responsible for phosphorylating the light chain of myosin to stimulate cross bridge cycling.

Cardiac glycosides are used therapeutically mainly in the treatment of congestive heart failure. These effects are caused by the ability to increase cardiac output by increasing the force of contraction by increasing intracellular calcium as described below, increasing calcium-induced calcium release and thus contraction. Drugs such as ouabain and digoxin are cardiac glycosides.

Normally, sodium-potassium pumps in the membrane of cells (in this case, cardiac myocytes) pump potassium ions in and sodium ions out. Cardiac glycosides inhibit this pump by stabilizing it in the E2-P transition state, so that sodium cannot be extruded, therefore increasing intracellular sodium concentration. A second membrane ion exchanger, NCX, is responsible for "pumping" calcium ions out of the cell and sodium ions in ($3Na/Ca$). Raised intracellular sodium levels inhibit this pump, so calcium ions are not extruded and will also begin to build up inside the cell.

Increased cytoplasmic calcium concentrations cause increased calcium uptake into the sarcoplasmic reticulum via the SERCA2 transporter. Raised calcium stores in the SR allow for greater calcium release on stimulation, so the myocyte can achieve faster and more powerful contraction by

cross-bridge cycling. The refractory period of the AV node is increased, so cardiac glycosides also function to regulate heart rate.

Binding of cardiac glycoside to Na—K ATPase is slow, and also, after binding, intracellular calcium increases gradually. This can be seen in the delayed action of digitalis, even on IV injection.

Raised extracellular potassium decreases binding of cardiac glycoside to Na—K ATPase, resulting in increased toxicity of these drugs in the presence of hypokalemia.

Digoxin binds to a site on the extracellular aspect of the α -subunit of the Na+/K+ ATPase pump in the membranes of heart cells (myocytes) and decreases its function. This causes an increase in the level of sodium ions in the myocytes, which leads to a rise in the level of intracellular calcium ions. This occurs because of a sodium/calcium exchanger on the plasma membrane, which depends on a constant inward sodium gradient to pump out calcium. Digoxin decreases sodium concentration gradient and the subsequent calcium outflow, thus raising the calcium concentration in myocardiocytes and pacemaker cells.

Increased intracellular calcium lengthens Phase 4 and Phase 0 of the cardiac action potential, which leads to a decrease in heart rate. Increased amounts of Ca²⁺ also leads to increased storage of calcium in the sarcoplasmic reticulum, causing a corresponding increase in the release of calcium during each action potential. This leads to increased contractility, the force of contraction, of the heart.

There is also evidence that digoxin increases vagal activity, thereby decreasing heart rate by slowing depolarization of pacemaker cells in the AV node. This negative chronotropic effect would therefore be synergistic with the direct effect on cardiac pacemaker cells. Digoxin is used widely in the treatment of various arrhythmias. Glutamate is the most abundant excitatory neurotransmitter in the vertebrate nervous system. At chemical synapses, glutamate is stored in vesicles. Nerve impulses trigger release of glutamate from the pre-synaptic cell. In the opposing post-synaptic cell, glutamate receptors, such as the NMDA receptor, bind glutamate and are activated. Because of its role in synaptic plasticity, glutamate is involved in cognitive functions like learning and memory in the brain. The form of plasticity known as long-term potentiation takes place at glutamatergic synapses in the hippocampus, neocortex, and other parts of the brain. Glutamate works not only as a point-to-point transmitter but also through spill-over synaptic crosstalk between synapses in which summation of glutamate released from a neighboring synapse creates extrasynaptic signaling/volume transmission.

Glutamate transporters are found in neuronal and glial membranes. They rapidly remove glutamate from the extracellular space. In brain injury or disease, they can work in reverse, and excess glutamate can accumulate outside cells. This process causes calcium ions to enter cells via NMDA receptor channels, leading to neuronal damage and eventual cell death, and is called excitotoxicity. The mechanisms of cell death include damage to mitochondria from excessively high intracellular Ca²⁺, and Glu/Ca²⁺-mediated promotion of transcription factors for pro-apoptotic genes, or downregulation of transcription factors for anti-apoptotic genes.

Excitotoxicity due to glutamate occurs as part of the ischemic cascade and is associated with stroke and diseases like amyotrophic lateral sclerosis, lathyrism, autism, some forms of mental retardation, and Alzheimer's disease.

Glutamic acid has been implicated in epileptic seizures. Microinjection of glutamic acid into neurons produces spontaneous depolarizations around one second apart, and this firing pattern is similar to what is known as paroxysmal

depolarizing shift in epileptic attacks. This change in the resting membrane potential at seizure foci could cause spontaneous opening of voltage-activated calcium channels, leading to glutamic acid release and further depolarization.

EXAMPLE 2

A vasoconstrictor (antidiuretic hormone (ADH or vasopressin) or tetrahydrozoline) is first administered to vessels surrounding the target site to minimize leakage of the priming or secondary agents.

A priming agent of proscillaridin at a concentration of 0.0001-10 mM in a volume of 0.05-2 cc is then administered at a nerve proximal site to prime the neurons by inhibiting the transport of potassium and sodium across the nerve cell membrane and subsequently inducing an intracellular calcium flux.

Approximately 0.1-20 minutes later, a secondary agent of domoic acid at a concentration of 0.00005-0.005 mM in a volume of 0.05-2 cc is then administered at a nerve proximal site to induce neuronal excitotoxicity.

Proscillaridin binds to a site on the extracellular aspect of the α -subunit of the Na+/K+ ATPase pump in the membranes of heart cells (myocytes) and decreases its function. This causes an increase in the level of sodium ions in the myocytes, which leads to a rise in the level of intracellular calcium ions. This occurs because of a sodium/calcium exchanger on the plasma membrane, which depends on a constant inward sodium gradient to pump out calcium. Proscillaridin decreases sodium concentration gradient and the subsequent calcium outflow, thus raising the calcium concentration in myocardiocytes and pacemaker cells.

Increased intracellular calcium lengthens Phase 4 and Phase 0 of the cardiac action potential, which leads to a decrease in heart rate. Increased amounts of Ca²⁺ also leads to increased storage of calcium in the sarcoplasmic reticulum, causing a corresponding increase in the release of calcium during each action potential. This leads to increased contractility, the force of contraction, of the heart.

There is also evidence that proscillaridin increases vagal activity, thereby decreasing heart rate by slowing depolarization of pacemaker cells in the AV node. This negative chronotropic effect would therefore be synergistic with the direct effect on cardiac pacemaker cells. Proscillaridin and other bufadienolides are not used widely in the United States, but are used in Europe to treatment of various arrhythmias.

Domoic acid can bioaccumulate in marine organisms such as shellfish, anchovies, and sardines that feed on the phytoplankton known to produce this toxin. DA can accumulate in high concentrations in the tissues of these plankton feeders when the toxic phytoplankton itself is high in concentration in the surrounding waters. In mammals, including humans, domoic acid acts as a neurotoxin, causing short-term memory loss, brain damage and, in severe cases, death. DA-producing algal blooms are associated with the phenomenon of amnesic shellfish poisoning (ASP).

In marine mammals, domoic acid typically causes seizures and tremors. In the brain, domoic acid especially damages the hippocampus and amygdaloid nucleus. It damages the neurons by activating AMPA and kainate receptors, causing an influx of calcium. Although calcium flowing into cells is a normal event, the uncontrolled increase of calcium causes the cell to degenerate. Because the hippocampus may be severely damaged, short-term memory loss occurs.

EXAMPLE 3

A vasoconstrictor (antidiuretic hormone (ADH or vasopressin) or tetrahydrozoline) is first administered to vessels surrounding the target site to minimize leakage of the priming or secondary agents.

A priming agent of N-Methyl-D-aspartic acid (NMDA) at a concentration of 0.01-300 mM in a volume of 0.05-2 cc is then administered at a nerve proximal site to prime the neurons by inducing excitatory intracellular signaling.

Approximately 0.1-20 minutes later, a secondary agent of digoxin at a concentration of 0.0001-10 mM in a volume of 0.05-2 cc is then administered at a nerve proximal site to inhibit the transport of potassium and sodium across the nerve cell membrane and subsequently induce high levels of intracellular calcium to mediate pro-apoptotic signaling and neuronal toxicity.

N-Methyl-D-aspartic acid (NMDA) is an amino acid derivative, which acts as a specific agonist at the NMDA receptor mimicking the action of glutamate, the neurotransmitter, which normally acts at that receptor. Unlike glutamate, NMDA only binds to and regulates the NMDA receptor and has no effect on other glutamate receptors (such as those for AMPA and kainate). NMDA receptors are particularly important when they become overactive during withdrawal from alcohol as this causes symptoms such as agitation and, sometimes, epileptiform seizures.

NMDA is a water-soluble synthetic substance that is not normally found in biological tissue. NMDA is an excitotoxin; this trait has applications in behavioral neuroscience research. The body of work utilizing this technique falls under the term "lesion studies." Researchers apply NMDA to specific regions of an (animal) subject's brain or spinal cord and subsequently test for the behavior of interest, such as operant behavior. If the behavior is compromised, it suggests the destroyed tissue was part of a brain region that made an important contribution to the normal expression of that behavior. However, in lower quantities NMDA is not neurotoxic. Therefore the action of glutamate specifically through NMDA receptors can be investigated by injecting small quantities of NMDA into a certain region in the brain: for example, injection of NMDA in a brainstem region induces involuntary locomotion in cats and rats.

EXAMPLE 4

A vasoconstrictor (antidiuretic hormone (ADH or vasopressin) or tetrahydrozoline) is first administered to vessels surrounding the target site to minimize leakage of the priming or secondary agents.

A priming agent of verapamil at a concentration of 0.1-600 mM in a volume of 0.05-2 cc is then administered at a nerve proximal site to interrupt potassium and sodium transport across the nerve cell membrane and prime the neurons by blocking calcium channels and inducing an intracellular signaling.

Approximately 0.1-20 minutes later, a secondary agent of carbamazepine at a concentration of 10-500 mM or lithium at a concentration of 0.5-400 mM in a volume of 0.05-2 cc is then administered at a nerve proximal site to interrupt potassium and sodium transport across the nerve cell membrane and induce neuronal toxicity.

Verapamil (brand names: Isoptin, Verelan, Verelan PM, Calan, Bosoptin, Covera-HS) is an L-type calcium channel blocker of the phenylalkylamine class. It has been used in the treatment of hypertension, angina pectoris, cardiac arrhythmia, and most recently, cluster headaches. It is also an effective

preventive medication for migraine. Verapamil has also been used as a vasodilator during cryopreservation of blood vessels. It is a class 4 anti-arrhythmic, more effective than digoxin in controlling ventricular rate. Verapamil's mechanism in all cases is to block voltage-dependent calcium channels.

In cardiac pharmacology, calcium channel blockers are considered class IV anti-arrhythmic agents. Since calcium channels are especially concentrated in the sinoatrial and atrio-ventricular nodes, these agents can be used to decrease impulse conduction through the AV node, thus protecting the ventricles from atrial tachy arrhythmias.

Calcium channels are also present in the smooth muscle that lines blood vessels. By relaxing the tone of this smooth muscle, calcium-channel blockers dilate the blood vessels. This has led to their use in treating hypertension and angina pectoris. The pain of angina is caused by a deficit in oxygen supply to the heart. Calcium channel blockers like verapamil will dilate blood vessels, which increases the supply of blood and oxygen to the heart. This controls chest pain, but only when used regularly. It does not stop chest pain once it starts. A more powerful vasodilator such as nitroglycerin may be needed to control pain once it starts. Verapamil is also used intra-arterially to treat cerebral vasospasm and cluster headaches.

Carbamazepine exhibits autoinduction: it induces the expression of the hepatic microsomal enzyme system CYP3A4, which metabolizes carbamazepine itself. Upon initiation of carbamazepine therapy, concentrations are predictable and follow their respective baseline clearance/half-life values that have been established for the specific patient. However, after enough carbamazepine has been presented to the liver tissue, the CYP3A4 activity increases, speeding up drug clearance and shortening the half-life. Auto-induction will continue with subsequent increases in dose but will usually reach a plateau within 5-7 days of a maintenance dose. Increases in dose at a rate of 200 mg every 1-2 weeks may be required to achieve a stable seizure threshold. Stable carbamazepine concentrations occur usually within 2-3 weeks after initiation of therapy. The mechanism of action of carbamazepine and its derivatives is relatively well understood. Voltage-gated sodium channels are the molecular pores that allow brain cells (neurons) to generate action potentials, the electrical events that allow neurons to communicate over long distances. After the sodium channels open to start the action potential, they inactivate, essentially closing the channel. Carbamazepine stabilizes the inactivated state of sodium channels, meaning that fewer of these channels are available to subsequently open, making brain cells less excitable (less likely to fire). Carbamazepine has also been shown to potentiate GABA receptors made up of alpha1, beta2, gamma2 subunits.

Lithium salts such as lithium carbonate (Li_2CO_3), lithium citrate, and lithium orotate are mood stabilizers. They are used in the treatment of bipolar disorder since, unlike most other mood altering drugs, they counteract both depression and mania (though more effective for the latter). Lithium continues to be the gold standard for the treatment of bipolar disorder. It is also helpful for related diagnoses, such as schizoaffective disorder and cyclic major depression. In addition to watching out for the well-known complications of lithium treatment—hypothyroidism and decreased renal function—health care providers should be aware of hyperparathyroidism. Lithium can also be used to augment antidepressants. Because of lithium's nephrogenic diabetes insipidus effects, it can be used to help treat the syndrome of inappropriate antidiuretic hormone hypersecretion (SIADH). It was

also sometimes prescribed as a preventive treatment for migraine disease and cluster headaches.

The active principle in these salts is the lithium ion Li⁺. Although this ion has a smaller diameter than either Na⁺ or K⁺, in a watery environment like the cytoplasmic fluid, Li⁺ binds to the oxygen atoms of water, making it effectively larger than either Na⁺ or K⁺ ions. How Li⁺ works in the central nervous system is still a matter of debate. Li⁺ elevates brain levels of tryptophan, 5-HT (serotonin), and 5-HIAA (a serotonin metabolite). Serotonin is related to mood stability. Li⁺ also reduces catecholamine activity in the brain (associated with brain activation and mania), by enhancing reuptake and reducing release. Therapeutically useful amounts of lithium (1.0 to 1.2 mmol/L) are only slightly lower than toxic amounts (>1.5 mmol/L), so the blood levels of lithium must be carefully monitored during treatment to avoid toxicity.

EXAMPLE 5

A vasoconstrictor (antidiuretic hormone (ADH or vasopressin) or tetrahydrozoline) is first administered to vessels surrounding the target site to minimize leakage of the priming or secondary agents.

A priming agent of digoxin at a concentration of 0.0001-10 mM in a volume of 0.05-2 cc is then administered at a nerve proximal site to prime the neurons by inducing an intracellular calcium flux.

Approximately 0.1-20 minutes later, a secondary agent of tetrodotoxin, hoiamide, or ω -conotoxin, each at a concentration of 0.00005-0.001 mM, in a volume of 0.05-0.5 cc is then administered at a nerve proximal site to block ion channels and induce neuronal toxicity.

Tetrodotoxin has been isolated from widely differing animal species, including western newts of the genus *Taricha* (where it was termed "tarichatoxin"), pufferfish, toads of the genus *Atelopus*, several species of blue-ringed octopodes of the genus *Hapalochlaena* (where it was called "maculotoxin"), several sea stars, certain angelfish, a polyclad flatworm, several species of *Chaetognatha* (arrow worms), several nemerteans (ribbonworms) and several species of xanthid crabs. The toxin is variously used as a defensive biotoxin to ward off predation, or as both a defensive and predatory venom (the octopodes, chaetognaths and ribbonworms). Tarichatoxin and maculotoxin were shown to be identical to tetrodotoxin in 1964 and 1978, respectively. Recent evidence has shown the toxin to be produced by bacteria within blue-ringed octopuses. The most common source of bacteria associated with TTX production is *Vibrio* bacteria, with *Vibrio alginolyticus* being the most common species. Pufferfish, chaetognaths, and nemerteans have been shown to contain *Vibrio alginolyticus* and TTX.

Tetrodotoxin binds to what is known as site 1 of the fast voltage-gated sodium channel. Site 1 is located at the extracellular pore opening of the ion channel. The binding of any molecules to this site will temporarily disable the function of the ion channel. Saxitoxin and several of the conotoxins also bind the same site. The use of this toxin as a biochemical probe has elucidated two distinct types of voltage-gated sodium channels present in humans: the tetrodotoxin-sensitive voltage-gated sodium channel (TTX-s Na⁺ channel) and the tetrodotoxin-resistant voltage-gated sodium channel (TTX-r Na⁺ channel). Tetrodotoxin binds to TTX-s Na⁺ channels with a binding affinity of 5-15 nanomolar, while the TTX-r Na⁺ channels bind TTX with low micromolar affinity. Nerve cells containing TTX-r Na⁺ channels are located primarily in cardiac tissue, while nerve cells containing TTX-s Na⁺ channels dominate the rest of the body. The prevalence of

TTX-s Na⁺ channels in the central nervous system makes tetrodotoxin a valuable agent for the silencing of neural activity within a cell culture.

The toxin blocks the fast Na⁺ current in human myocytes (the contractile cells of the muscles), thereby inhibiting their contraction. By contrast, the sodium channels in pacemaker cells of the heart are of the slow variety, so action potentials in the cardiac nodes are not inhibited by the compound. The myocytes in the atrium, which surround the main cardiac pacemaker, do express this fast Na⁺ current and therefore the electrical activity is blocked and the heart fails to beat.

A conotoxin is one of a group of neurotoxic peptides isolated from the venom of the marine cone snail, genus *Conus*. Conotoxins, which are peptides consisting of 10 to 30 amino acid residues, typically have one or more disulfide bonds. Conotoxins have a variety of mechanisms of actions, most of which have not been determined. Many of these peptides modulate the activity of ion channels.

ω -conotoxins have a knotting or inhibitor cysteine knot scaffold. The knotting scaffold is a very special disulfide-through-disulfide knot, in which the III-VI disulfide bond crosses the macrocycle formed by two other disulfide bonds (I-IV and II-V) and the interconnecting backbone segments, where I-VI indicates the six-cysteine residues starting from the N-terminus. The cysteine arrangements are the same for omega, delta and kappa families, even though omega conotoxins are calcium channel blockers, whereas delta conotoxins delay the inactivation of sodium channels, and kappa conotoxins are potassium channel blockers. Ziconotide is derived from the toxin of the cone snail species *Conus magus*.

The following table lists agents and examples of concentrations for which they may be used for denervation at a volume of approximately 2 cc.

AGENT	CAS NUMBER	MW	CONCENTRATION RANGE
Digoxin	20830-75-5	780.94 g/mol	0.01-10 microM
Staurosporine	62996-74-1	466.54 g/mol	0.1-100 microM
Amlodipine	88150-42-9	408.88 g/mol	0.25-250 microM
Verapamil	52-53-9	454.60 g/mol	0.1-500 microM
Cymarin	508-77-0	548.66 g/mol	0.1-10 microM
Digitoxin	71-63-6	764.94 g/mol	0.1-10 microM
Proscillaridin	466-06-8	530.65 g/mol	0.1-10 microM
Ouabain	630-60-4	584.65 g/mol	0.01-10 microM
Veratridine	71-62-5	673.79 g/mol	10-100 microM
Glutamate	617-65-2	147.13 g/mol	0.1-800 microM
Domoic acid	14277-97-5	311.33 g/mol	0.01-100 microM
Oleandrin	465-16-7	576.72 g/mol	0.01-10 microM
Carbamazepine	298-46-4	236.27 g/mol	1-900 microM

FIG. 10A shows the amount of cell death caused by several of agents for a fixed amount of time. Primary nerve cell death was measured using percent trypan blue positive. Primary nerve cells were incubated in the presence of the agents for 15 minutes, washed with fresh media, and incubated for 30 minutes at 37° C. prior to trypan blue scoring. Cell death was assessed by the percentage of cells in the field that were trypan blue positive. Three hundred cells per condition (100 cells per well, 3 wells per condition) were counted using a light microscope.

FIG. 10B shows the amount of cell death caused by several agents versus time. Primary nerve cells were incubated at 37° C. in the presence of the agents for 5, 10, 30, and 60 minutes, washed with fresh media, and evaluated by trypan blue scoring. Cell death was assessed by the percent of cells in the field that were trypan blue positive. Three hundred cells per condition (100 cells per well, 3 wells per condition) were counted using a light microscope.

The description and examples given above describe the denervation of renal nerves surrounding the renal arteries to control hypertension. However, the described devices, methods, agents and delivery methods may be used to treat other diseases. These include and are not limited to diabetes (insulin production levels), fibromyalgia, pain management, and obesity.

While the foregoing has been with reference to particular embodiments of the invention, it will be appreciated by those skilled in the art that changes in these embodiments may be made without departing from the principles and spirit of the invention.

What is claimed is:

1. A method for killing targeted renal nerve cells in a mammal, the method comprising:
 - delivering a cardiac glycoside locally to the renal nerve cells in an amount sufficient to potentiate the toxicity effects of an excitatory signal induced by glutamate;
 - delivering glutamate locally to the renal nerve cells in an amount sufficient to overstimulate the renal nerve cells to promote apoptosis of the renal nerve cells and treat hypertension in the mammal.
2. The method of claim 1, wherein the cardiac glycoside is digoxin, proscillaridin, or ouabain.
3. The method of claim 1, further comprising:
 - delivering digoxin immune Fab to tissue surrounding the renal nerve cells, the digoxin immune Fab being capable of neutralizing any excess cardiac glycoside.

4. The method of claim 1, further comprising:
 - delivering an anesthetic to tissue surrounding the renal nerve cells before delivering the cardiac glycoside.
5. The method of claim 1, further comprising:
 - delivering saline to tissue surrounding the renal nerve cells to flush any excess cardiac glycoside or glutamate.
6. A method for killing targeted renal nerve cells in a mammal, the method comprising:
 - delivering a cardiac glycoside locally to the renal nerve cells in an amount sufficient to potentiate the toxicity effects of carbamazepine; and
 - delivering carbamazepine locally to the renal nerve cells in an amount sufficient to block an action potential and repolarization of the renal nerve cells to kill the renal nerve cells and treat hypertension in the mammal.
7. The method of claim 6, wherein the cardiac glycoside is digoxin, proscillaridin, or ouabain.
8. The method of claim 6, further comprising:
 - delivering digoxin immune Fab to tissue surrounding the renal nerve cells, the digoxin immune Fab being capable of neutralizing any excess cardiac glycoside.
9. The method of claim 6, further comprising:
 - delivering an anesthetic to tissue surrounding the renal nerve cells before delivering the cardiac glycoside.
10. The method of claim 6, further comprising:
 - delivering saline to tissue surrounding the renal nerve cells to flush any excess cardiac glycoside.

* * * * *

专利名称(译)	肾去神经支配的方法		
公开(公告)号	US8975233	公开(公告)日	2015-03-10
申请号	US13/014700	申请日	2011-01-26
[标]申请(专利权)人(译)	EVANS迈克尔 VENKATESWARA饶KONDAPAVULURŤ 艾米丽·A·斯坦		
申请(专利权)人(译)	EVANS迈克尔 VENKATESWARA-RAO KONDAPAVULURŤ STEIN艾米莉		
当前申请(专利权)人(译)	NORTHWIND MEDICAL , INC.		
[标]发明人	STEIN EMILY A VENKATESWARA RAO KONDAPAVULUR T EVANS MICHAEL A		
发明人	STEIN, EMILY A. VENKATESWARA-RAO, KONDAPAVULUR T. EVANS, MICHAEL A.		
IPC分类号	A61K31/704 A61B5/00 A61B5/0215 A61B17/22 A61B19/00 A61F2/958 A61K31/7048 A61M25/00 A61M25/04 A61M25/10		
CPC分类号	A61M25/0084 A61K31/7048 A61B5/0215 A61B5/4839 A61B2017/22054 A61B2017/22061 A61B2017/22067 A61B2019/5276 A61B2019/528 A61M25/04 A61M2025/0086 A61M2025/0087 A61M2025/1047 A61B5/4094 A61B2090/378 A61B2090/3784 A61K31/198 A61K31/55 A61K45/06 A61P25/00 A61K2300/00		
优先权	61/336838 2010-01-26 US		
其他公开文献	US20110182912A1		
外部链接	Espacenet USPTO		

摘要(译)

描述了各种药剂以使肾神经和其他神经组织起作用，调节或以其他方式影响肾神经和其他神经组织。此外，描述了各种递送装置以将药剂局部递送至肾神经。递送装置定位在肾动脉中并穿透肾动脉壁以将药剂递送至肾神经。输送装置可用于根据肾神经的纵向位置，径向位置和深度相对于肾动脉输送药剂。另外，描述了各种方法来去神经，调节或以其他方式影响肾神经和其他神经组织。

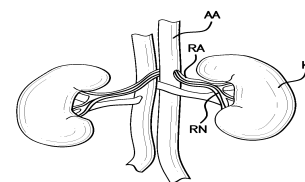

FIG. 1A

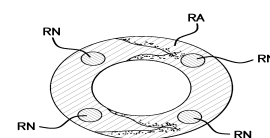

FIG. 1B