



US 20130231550A1

(19) **United States**
(12) **Patent Application Publication**
Weinstein et al.

(10) **Pub. No.: US 2013/0231550 A1**
(43) **Pub. Date: Sep. 5, 2013**

(54) **IMPLANTABLE RADIO-FREQUENCY SENSOR**

Publication Classification

(75) Inventors: **Uriel Weinstein**, Mazkeret Batia (IL); **Assaf Bernstein**, Givat Nilly (IL); **Eyal Cohen**, Ariel (IL); **Dov Oppenheim**, Jerusalem (IL); **Moshe Mosesko**, Kadima (IL)

(51) **Int. Cl.**
A61B 5/0205 (2006.01)
A61B 5/00 (2006.01)
(52) **U.S. Cl.**
CPC *A61B 5/0205* (2013.01); *A61B 5/0059* (2013.01)
USPC **600/407**

(73) Assignee: **KYMA MEDICAL TECHNOLOGIES LTD.**, Kfar Saba (IL)

(57) **ABSTRACT**

(21) Appl. No.: **13/811,210**

Diagnostic apparatus (24) includes a sealed case (40), including a biocompatible material and configured for implantation within a body of a human subject (22). At least one antenna (42) is configured to be implanted in the body in proximity to a target tissue (28) and to receive radio frequency (RF) electromagnetic waves propagated through the target tissue and to output a signal in response to the received waves. Processing circuitry (44, 46), which is contained within the case, is coupled to receive and process the signal from the antenna so as to derive and output an indication of a characteristic of the target tissue

(22) PCT Filed: **Jul. 21, 2011**

(86) PCT No.: **PCT/IB11/53244**

§ 371 (c)(1),
(2), (4) Date: **Mar. 8, 2013**

Related U.S. Application Data

(60) Provisional application No. 61/366,173, filed on Jul. 21, 2010.

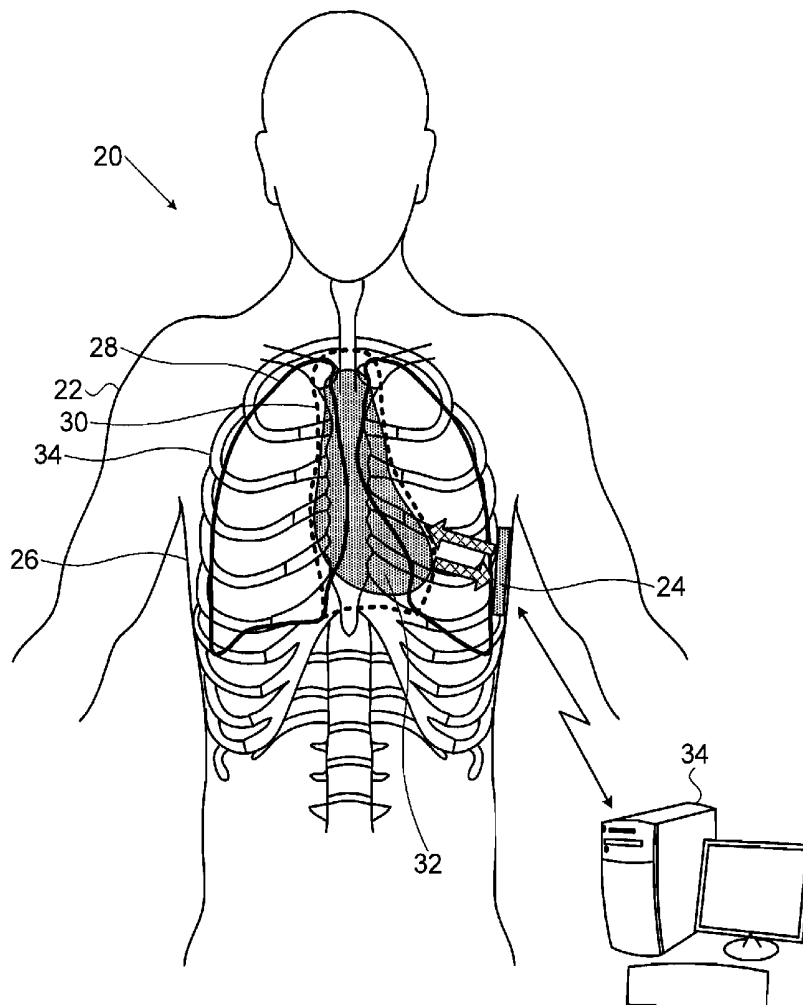

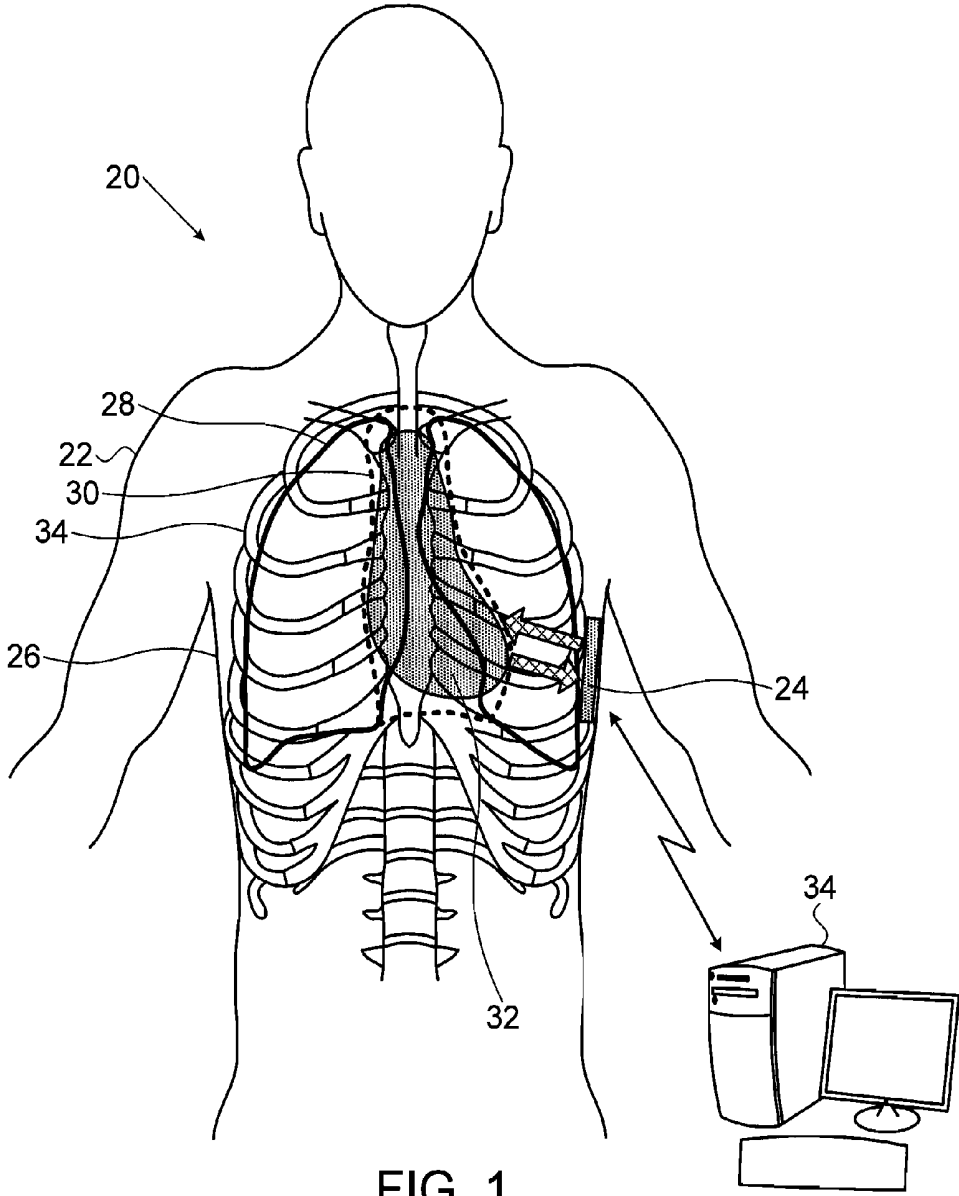

FIG. 1

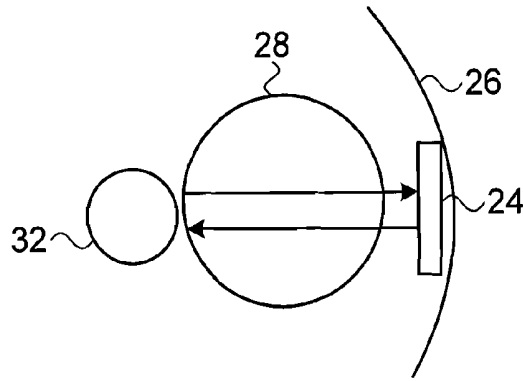

FIG. 2

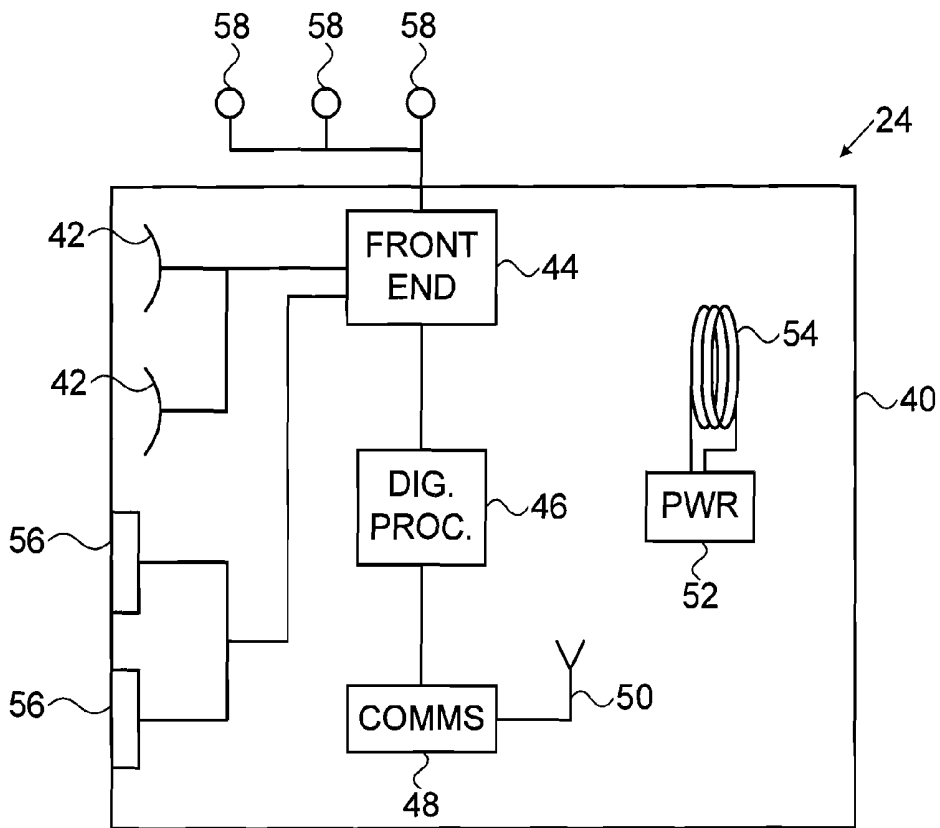
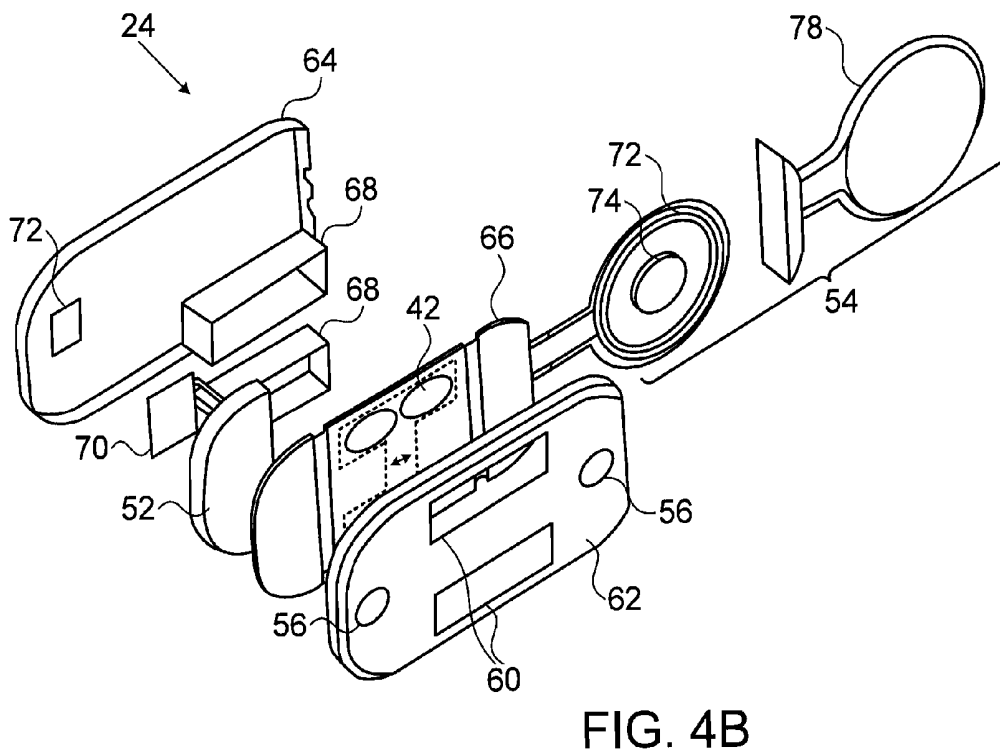
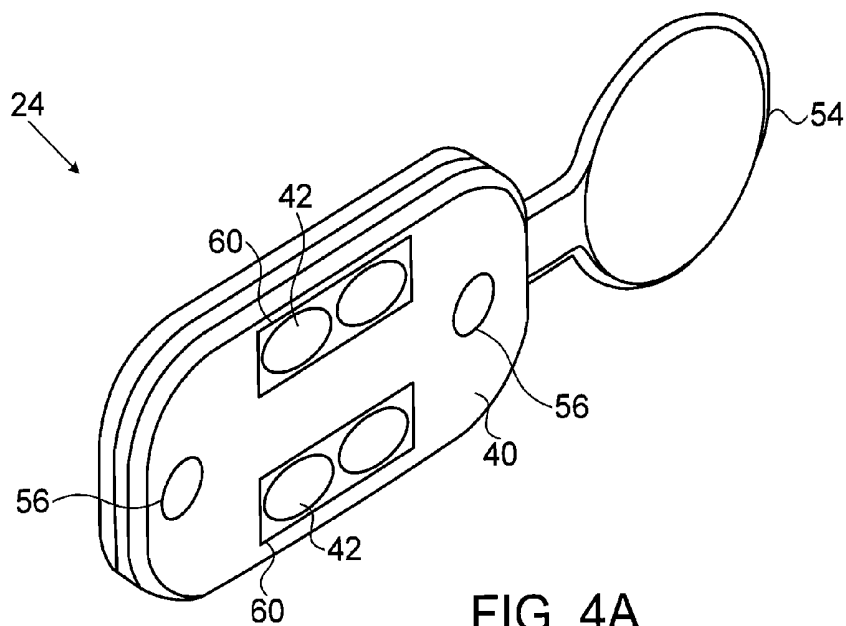

FIG. 3



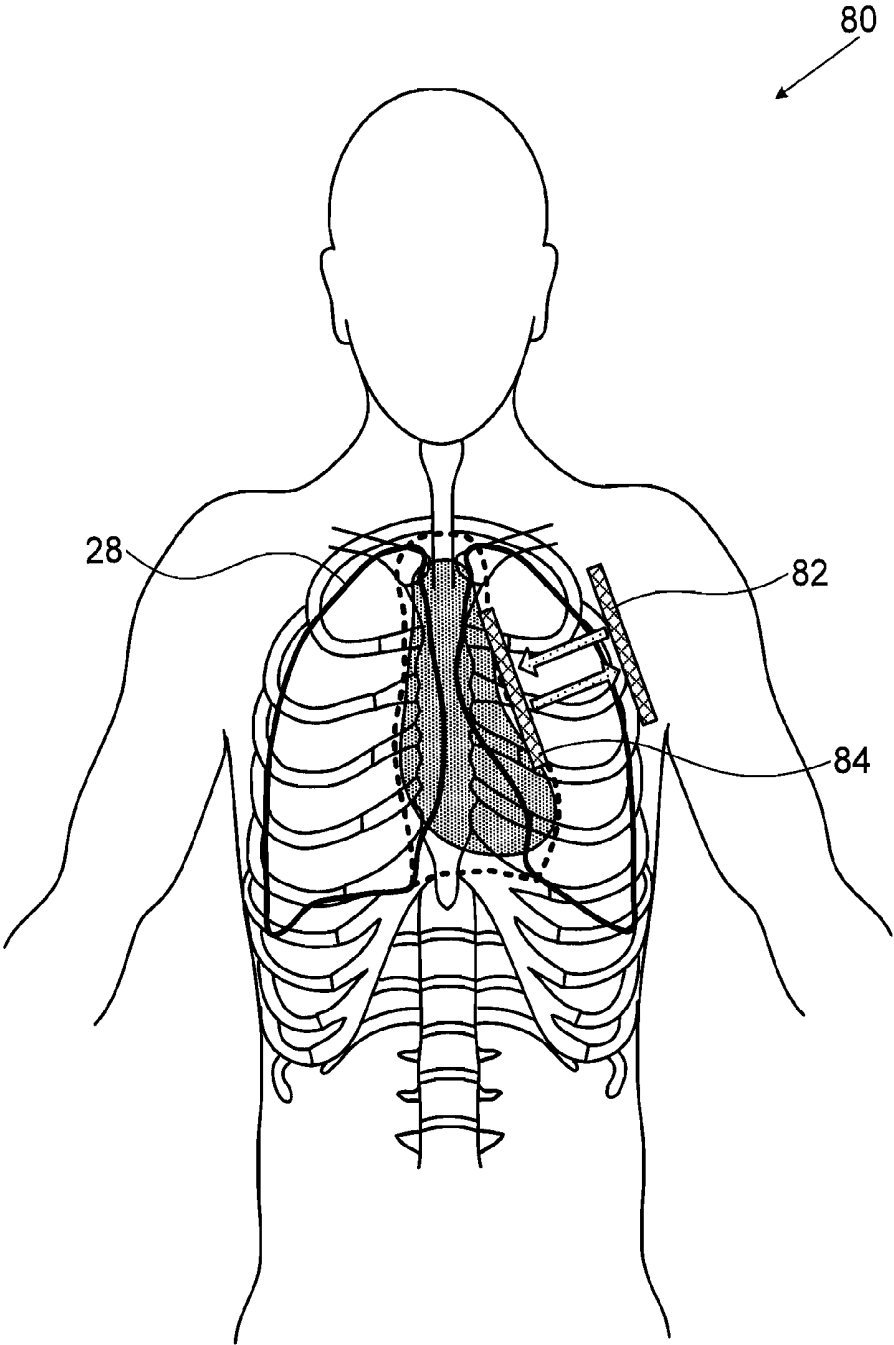

FIG. 5

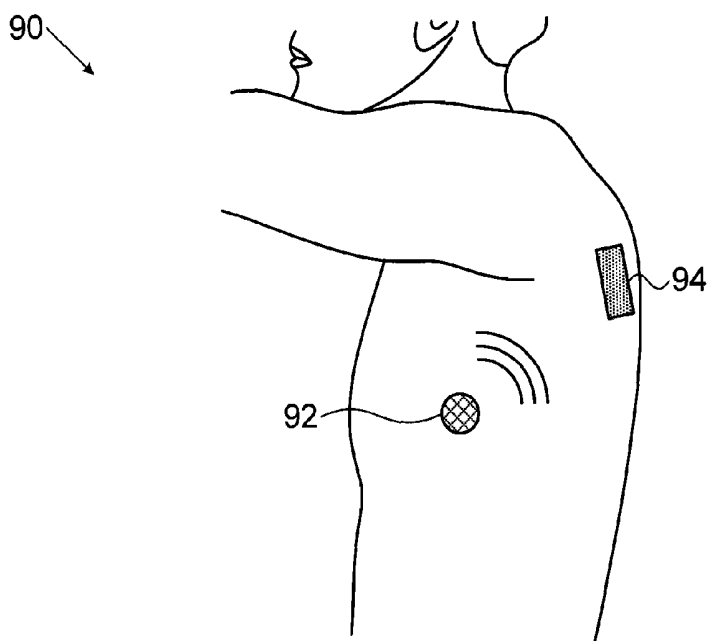

FIG. 6A

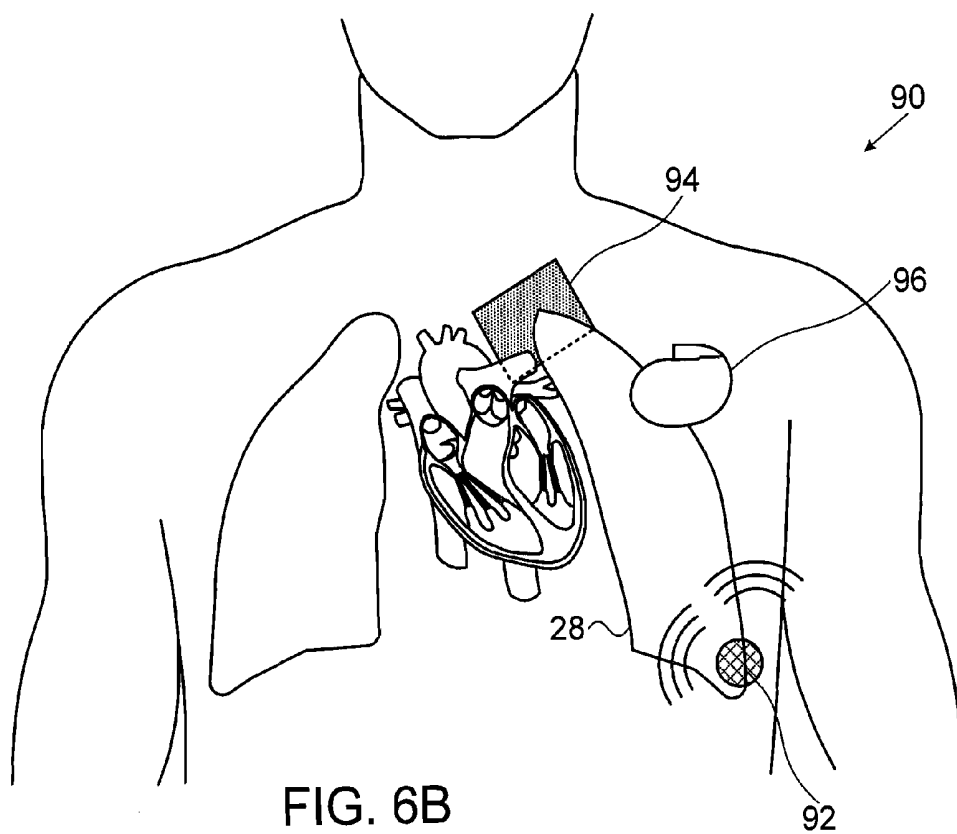

FIG. 6B

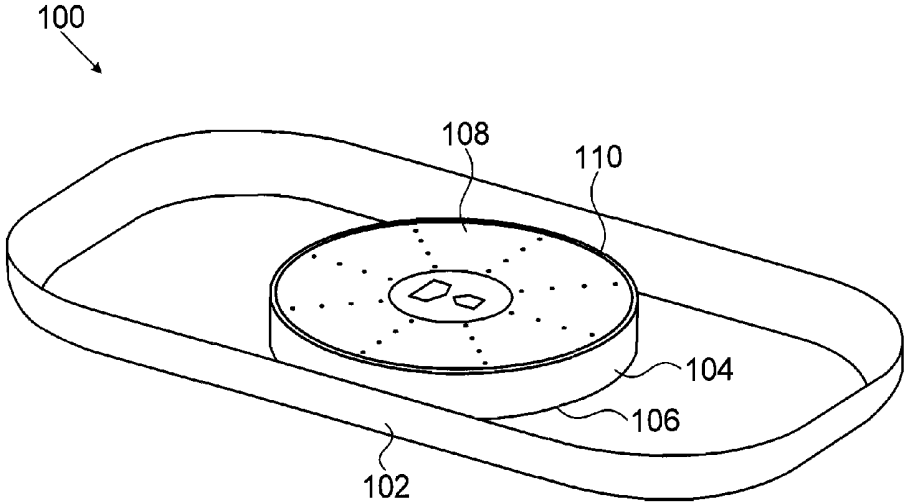

FIG. 7

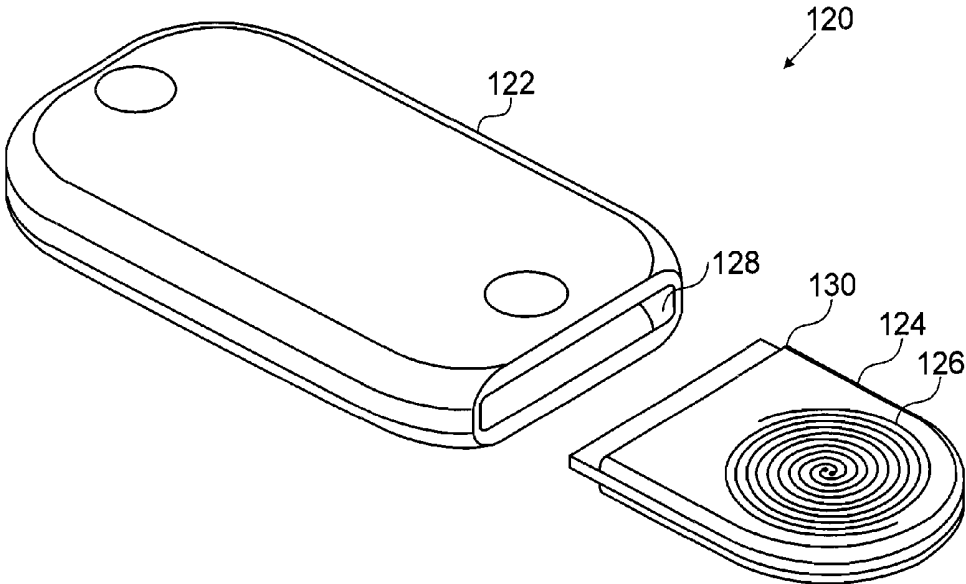

FIG. 8

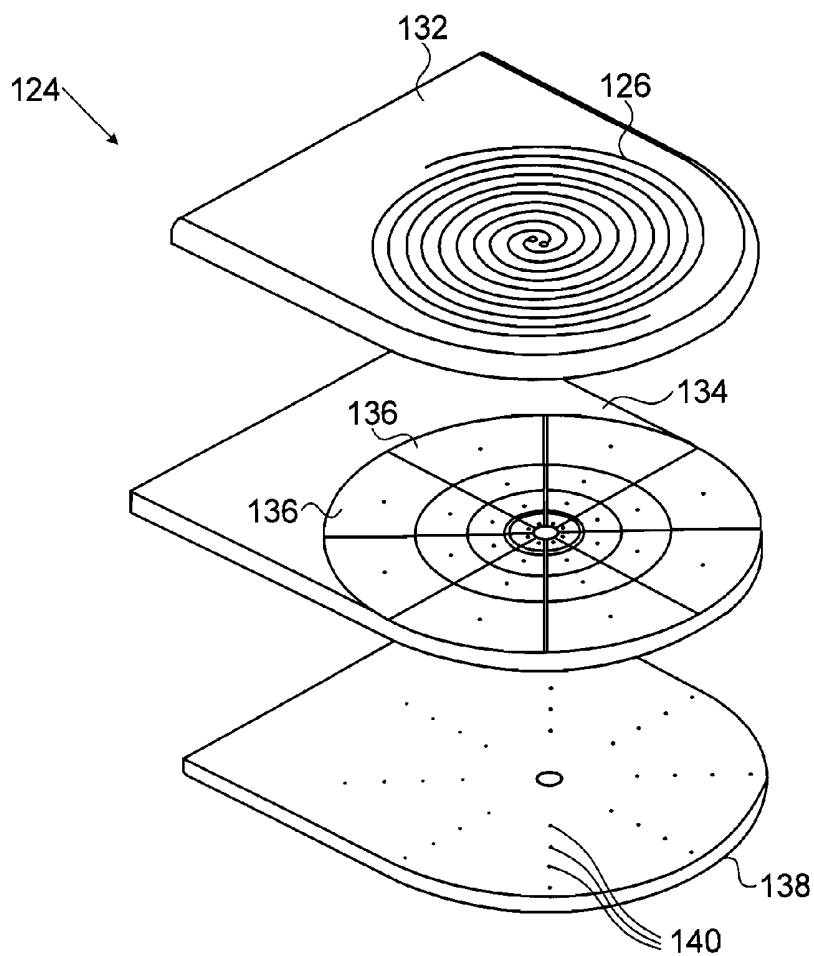

FIG. 9

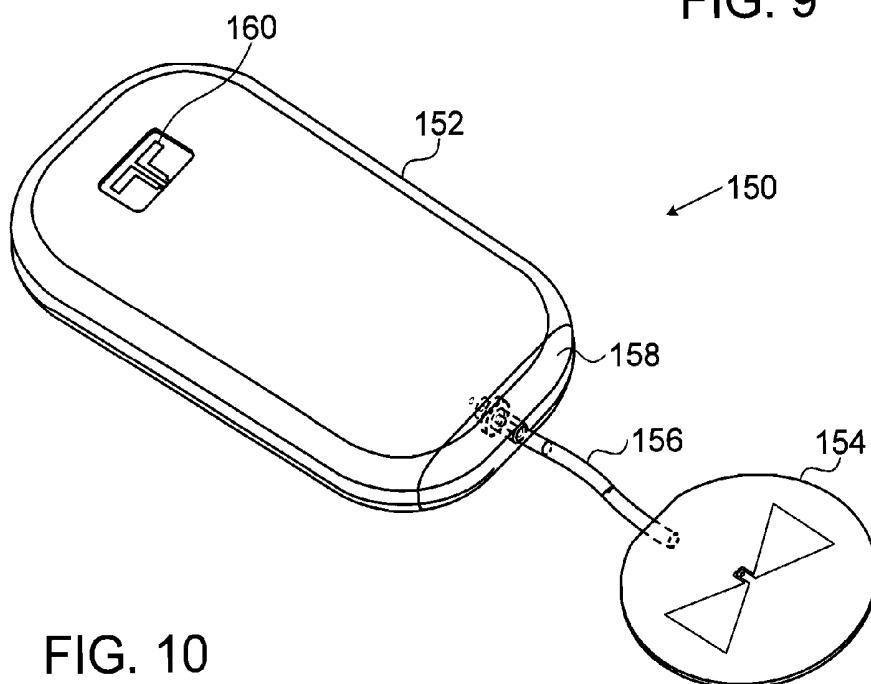

FIG. 10

IMPLANTABLE RADIO-FREQUENCY SENSOR

CROSS-REFERENCE TO RELATED APPLICATION

[0001] This application claims the benefit of U.S. Provisional Patent Application 61/366,173, filed Jul. 21, 2010, which is incorporated herein by reference.

FIELD OF THE INVENTION

[0002] The present invention relates generally to methods and systems for medical diagnostic measurement and monitoring, and specifically to radio frequency (RF)-based measurement and monitoring of physiological conditions.

BACKGROUND OF THE INVENTION

[0003] Radio-frequency (RF) electromagnetic radiation has been used for diagnosis and imaging of body tissues. For example, PCT International Publication WO 2011/067623, which is assigned to the assignee of the present patent application and whose disclosure is incorporated herein by reference, describes diagnostic apparatus that includes an antenna, which directs RF electromagnetic waves into a living body and generates signals responsively to the waves that are scattered from within the body. The signals are processed so as to locate a feature in a blood vessel in the body.

[0004] As another example, U.S. Patent Application Publication 2011/0130800, which is assigned to the assignee of the present patent application and whose disclosure is incorporated herein by reference, describes diagnostic apparatus, which includes a plurality of antennas, which are configured to be disposed at different, respective locations on the thorax of a living body. The antennas direct radio frequency (RF) electromagnetic waves from different, respective directions toward the heart in the body and output RF signals responsively to the waves that are scattered from the heart. The RF signals are processed over time so as to provide a multi-dimensional measurement of a movement of the heart.

[0005] U.S. Patent Application Publication 2010/0256462 describes a method for monitoring thoracic tissue fluid content by intercepting reflections of electromagnetic (EM) radiation reflected from thoracic tissue of a patient in radiation sessions during a period of at least 24 hours. A change of a dielectric coefficient of the thoracic tissue is detected by analyzing the reflections. PCT International Publication WO 2009/031149 describes a wearable monitoring apparatus comprising at least one transducer configured for delivering EM radiation to internal tissue and intercepting at least one reflection of the EM radiation therefrom. A housing for containing the transducer, along with a reporting unit and a processing unit, is configured to be disposed on the body of an ambulatory user.

[0006] The citation of certain references above is intended to provide a general overview of the state of the art and does not constitute an admission that any of the references should be considered prior art against the present patent application.

SUMMARY

[0007] Embodiments of the present invention that are described hereinbelow provide implantable devices for measuring tissue characteristics using RF electromagnetic radiation and methods of measurement and monitoring using such devices.

[0008] There is therefore provided, in accordance with an embodiment of the present invention, diagnostic apparatus, including a sealed case, which includes a biocompatible material and configured for implantation within a body of a human subject. At least one antenna is configured to be implanted in the body in proximity to a target tissue and to receive radio frequency (RF) electromagnetic waves propagated through the target tissue and to output a signal in response to the received waves. Processing circuitry, which is contained within the case, is coupled to receive and process the signal from the antenna so as to derive and output an indication of a characteristic of the target tissue.

[0009] In some embodiments, the at least one antenna is configured to transmit the waves into the body and to receive the transmitted waves following propagation of the waves through the target tissue. In a disclosed embodiment, the at least one antenna is configured to receive the waves after reflection of the waves from a tissue in the body, and the processing circuitry is configured to detect a modulation of the reflection due to at least one of a heartbeat and a respiratory motion of the subject. The modulation may include a cyclical variation due to the heartbeat.

[0010] Additionally or alternatively, the apparatus may include a reflector configured for implantation in the body in a location across the target tissue from the case containing the at least one antenna, wherein the reflector serves as the structure for reflecting the waves toward the at least one antenna. The reflector may be a part of an implanted cardiac device (ICD) that is implanted in the body.

[0011] In another embodiment, the apparatus includes a transmitter, which is configured to be implanted in the body in a location across the target tissue from the case containing the at least one antenna and to transmit the waves through the target tissue.

[0012] In some embodiments, the processing circuitry is configured to process the signal so as to derive a measure of a fluid content of the target tissue. In a disclosed embodiment, the case is configured for implantation in a thorax, and the target tissue is lung tissue. In alternative embodiments, the target tissue is spleen, liver, tongue or palate tissue.

[0013] In one embodiment, the indication includes a time trend of the characteristic of the target tissue.

[0014] The at least one antenna may include a plurality of antennas. In one embodiment, the processing circuitry is configured to drive the antennas in a multi-static mode so as to spatially resolve the characteristic of the target tissue.

[0015] In some embodiments, the at least one antenna is contained inside the case. Typically, the at least one antenna includes a trace printed on a substrate, and wherein the case includes a window, and the antenna is configured to receive the waves through the window. The substrate may be sealed to the case by brazing.

[0016] In another embodiment, the at least one antenna is located partially outside the case and is connected to the processing circuitry via a sealed brazing to the case.

[0017] In some embodiments, the at least one antenna includes a trace printed on a substrate and a backlobe suppression structure behind the trace. The backlobe suppression structure may be selected from a group of structures consisting of an air cavity and an electromagnetic bandgap (EBG) backing.

[0018] The at least one antenna may be selected from a group of antenna types consisting of a spiral antenna, a bowtie antenna, an elliptic bowtie antenna, and a slotted antenna.

[0019] In a disclosed embodiment, the processing circuitry is configured to convey the indication of the characteristic via a wireless link to a monitoring station outside the body. Additionally or alternatively, the processing circuitry may be configured to communicate with at least one other implanted device.

[0020] The at least one antenna may also be configured to receive electrical energy to power the processing circuitry via an inductive link to a transmitter outside the body. Alternatively, the apparatus includes a power antenna, which is configured to receive electrical energy to power the processing circuitry via an inductive link to a transmitter outside the body.

[0021] In a disclosed embodiment, the apparatus includes one or more electrodes on the case for receiving electrical signals within the body. Additionally or alternatively, the apparatus may include a bio-impedance sensor. Further additionally or alternatively, the apparatus includes an implanted cardiac device, which is configured to pace a heart of the subject responsively to the indication provided by the processing circuitry.

[0022] There is also provided, in accordance with an embodiment of the present invention, diagnostic apparatus including a radio frequency (RF) reflector, which is configured to be implanted in a body of a human subject in proximity to a target tissue. A diagnostic device is configured to transmit RF electromagnetic waves toward the RF reflector and to receive the waves reflected by the RF reflector through the target tissue, and to process the received waves so as to derive and output an indication of a characteristic of the target tissue.

[0023] There is additionally provided, in accordance with an embodiment of the present invention, a diagnostic method, which includes implanting a diagnostic device in proximity to a target tissue in a body of a human subject. The device receives radio frequency (RF) electromagnetic waves propagated through the target tissue and processes the received waves so as to derive an indication of a characteristic of the target tissue.

[0024] In a disclosed embodiment, implanting the device includes using an external antenna outside the body to identify an optimal location for implantation of the device.

[0025] The present invention will be more fully understood from the following detailed description of the embodiments thereof, taken together with the drawings in which:

BRIEF DESCRIPTION OF THE DRAWINGS

[0026] FIG. 1 is a schematic pictorial illustration showing a monitoring system including an implanted RF monitoring device, in accordance with an embodiment of the invention;

[0027] FIG. 2 is a schematic sectional view of a RF monitoring device implanted in a human body, in accordance with an embodiment of the invention;

[0028] FIG. 3 is a block diagram that schematically shows functional components of an implantable RF monitoring device, in accordance with an embodiment of the invention;

[0029] FIG. 4A is a schematic pictorial illustration of an implantable RF monitoring device, in accordance with an embodiment of the invention;

[0030] FIG. 4B is a schematic exploded view of the device of FIG. 4A;

[0031] FIG. 5 is a schematic pictorial illustration showing a RF monitoring device implanted in a human body, in accordance with another embodiment of the invention;

[0032] FIGS. 6A and 6B are schematic pictorial illustrations, in side and front views respectively, showing a RF monitoring device implanted in a human body, in accordance with a further embodiment of the invention;

[0033] FIG. 7 is a schematic pictorial illustration of a part of a RF monitoring device, in accordance with another embodiment of the present invention;

[0034] FIG. 8 is a schematic, partly-exploded view of a RF monitoring device, in accordance with yet another embodiment of the present invention;

[0035] FIG. 9 is a schematic exploded view of an antenna used in the embodiment of FIG. 8; and

[0036] FIG. 10 is a schematic pictorial illustration of a RF monitoring device, in accordance with an additional embodiment of the present invention.

DETAILED DESCRIPTION OF EMBODIMENTS

Overview

[0037] A number of chronic medical conditions lead to accumulation of fluid in and around body organs. For example, pulmonary edema is associated with chronic heart failure and other pathologies. As another example, conditions such as kidney failure and certain inflammatory disorders may lead to pericardial effusion. Monitoring such fluid levels in the patient's body over extended periods can be helpful in ongoing risk assessment and adjustment of treatment. Similarly, monitoring accumulation of blood in the splanchnic system can be of medical benefit in assessing fluid status.

[0038] Embodiments of the present invention that are described hereinbelow provide implantable devices and methods that can be used for long-term measurement and monitoring of tissue characteristics, such as fluid accumulation in and around body organs. In these embodiments, a diagnostic device comprises at least one antenna and associated processing circuitry, which are contained inside or connected to a sealed case made from a biocompatible material. The device is implanted within the body of a human subject in proximity to a target tissue, such as the lung. The antenna receives radio frequency (RF) electromagnetic waves transmitted through the target tissue. These waves may be transmitted by the antenna itself and then reflected back through the target tissue to the device, or they may be transmitted from another source. The processing circuitry processes the signals that are output by the antenna in order to derive and output an indication of a characteristic of the target tissue, such as the tissue fluid content.

[0039] In a disclosed embodiment, the device is implanted in the thorax, adjacent to the lung. The processing circuitry drives the antenna (or antennas) to transmit RF waves through the lung toward the heart, and to receive waves reflected from the heart and transmitted back through the lung. Alternatively, the waves may be reflected back from a dedicated reflector or another reflective object. Further alternatively, the waves may be transmitted through the lung by a separate transmitter, which is implanted in the body in a location across the target tissue from the receiver. The processing circuitry processes the output signals from the antenna in order to derive a measure of the fluid content of the lung. The processing circuitry periodically reports the fluid level by telemetric link to a monitor outside the patient's body, for use by a physician in tracking the patient's condition and making treatment changes as appropriate.

[0040] Although the embodiments described herein are directed specifically to monitoring of fluid levels in the lungs, the principles of the present invention may similarly be applied in other monitoring applications. For example, implanted devices of the types described herein may be used, *mutatis mutandis*, in monitoring pericardial fluid levels. As another example, such a device may be used to monitor bladder fill level and/or muscle properties in patients suffering from urinary disorders, in order to provide an alert when the bladder should be emptied. In other embodiments, such devices may be used in long-term monitoring of fluid levels in the brain, tongue, palate or spleen, as well as in body extremities, such as the thighs. More generally, the devices and methods described herein may be adapted for use in substantially any long-term diagnostic application in which tissue characteristics are evaluated using RF electromagnetic waves, including not only fluid monitoring but also imaging applications, as well.

System Description

[0041] Reference is now made to FIGS. 1 and 2, which schematically illustrate a RF-based monitoring system 20, in accordance with an embodiment of the invention. FIG. 1 is a pictorial illustration, showing a RF monitoring device 24 implanted in a thorax 26 of a patient 22, while FIG. 2 is a sectional view taken through the body, showing the relation of device 24 to organs in the thorax. Device 24, which is typically similar in shape and size to a conventional implanted cardiac device (ICD), such as a pacemaker, is implanted below the patient's skin adjacent to ribs 34 and transmits and receives RF electromagnetic waves through target tissue, such as a lung 28, as indicated by arrows in the figure.

[0042] In the pictured example, device 24 is implanted in the axillary region using a minimally-invasive procedure. The waves transmitted by device 24 pass through lung 28 and mediastinum 30, reflect back from heart 32 through lung 28, and are then received and detected by device 24. Alternatively, the device may be implanted in other suitable locations, such as the infra-mammary or dorsal regions of thorax 26. An external antenna may be used during implantation to choose an optimal antenna location, based upon which the surgeon implants device 24 and its implanted antenna at the location giving the best signal. In some alternative embodiments, as shown in FIGS. 5, 6A and 6B, for example, the monitoring device may be used in conjunction with an implanted reflector, instead of or in addition to sensing reflections from the heart.

[0043] RF monitoring device 24 processes the received RF waves to derive an indication of tissue characteristics, such as tissue fluid content. Device 24 collects these indications over time and periodically transmits the data to a telemetry station 34, typically via a suitable short-range wireless link. Station 34 typically comprises a general-purpose computer with suitable communication circuits and software, and may be located in a clinic or hospital or in the home or workplace of patient 22. Station 34 may also be configured to program device 24 over the wireless link, as well as to provide RF energy to recharge the battery in device 24, as described below.

[0044] FIG. 3 is a block diagram that schematically shows functional elements of RF monitoring device 24, in accordance with an embodiment of the invention. The elements of device 24 are contained in a sealed case 40, comprising a suitable biocompatible material, such as titanium or stainless

steel. The case may be coated with a tissue-growth inducing material, as is known in the art. Case 40 contains, *inter alia*, processing circuitry including a RF front end 44 and a digital processing circuit 46. Front end 44 drives one or more antennas 42 to emit RF waves through lung 28. The front end receives and processes the signals that are output by antennas 42 in response to the reflected waves and outputs a digitized indication of the amplitude and phase of the signals to digital processing circuit 46. Typically, for high resolution in the presence of background noise, front end 44 and circuit 46 apply coherent methods of signal processing to correlate the reflected signals with the transmitted signals, but alternatively non-coherent processing methods may be used.

[0045] In one embodiment, front end 44 generates signals at multiple different frequencies for exciting the transmitting antennas. Device 24 may operate in an ultra-wide-band (UWB) mode, in which the signals are spread over a wide range of frequencies, such as from about 500 MHz to about 2.5 GHz (although higher and lower frequencies outside this range may also be used). UWB transmission and detection techniques of this sort are described, for example, in the above-mentioned PCT International Publication WO 2011/067623 and U.S. Patent Application Publication 2011/0130800. The UWB signal provides the frequency-domain equivalent of a very short pulse in the time domain and can thus be used for measuring the range of a reflecting spot in the body with high accuracy. The UWB signal can be transmitted as a short pulse or as a train of narrowband signals that together constitute a wideband signal, or other waveforms used in radar pulse compression (such as chirped, stepped-frequency, or phase-coded pulses). Use of these sorts of waveforms in making measurements inside the body is described in the above-mentioned publications and may similarly be applied, *mutatis mutandis*, in system 20.

[0046] Digital processing circuit 46 measures the time delay for RF waves to travel from antenna 42 to heart 32 via lung 28 and back to the antenna. The waves reflected from the heart can be identified based on the modulation, typically comprising a cyclical change, of the resulting signal during a heartbeat. The short-term time cyclical variation of the delay from antenna to heart and back can also be used to measure heart movement, while long-term variation is indicative of changes in the pulmonary fluid level. Additionally or alternatively, electrodes 56, which may be built into case 40 or mounted externally, may measure an electrocardiogram (ECG) signal for correlation with the actual heart movement. Further additionally or alternatively, circuit 46 may detect modulation of the waves due to respiratory motion.

[0047] Further additionally or alternatively, device may comprise other sensors 58, either in case 40 or connected to it externally. Sensors 58 may measure, for example, bio-impedance, fluid content, temperature, salinity, or motion (of the heart, lungs, or entire body) and may be useful in filling out the picture of fluid status that is provided by RF measurement.

[0048] As the RF waves pass through body tissue, such as lung 28, the group velocity of the waves will vary as a function of the fluid content of the tissue. Generally speaking, the higher the fluid content, the greater will be the dielectric constant of the tissue, and hence the lower the velocity. Equivalently, fluid in the lungs can be considered to increase the RF path length of the waves, defined by the length of time required for the waves to pass through the tissue and back to device 24. The result of this decrease in velocity or increase in RF path length is that the delay of the reflected waves will

increase as the fluid content of lungs **28** increases. Digital processing circuit **46** measures this delay periodically and/or on command in order to compute an indication of the lung's fluid content. Typically, circuit **46** comprises a memory (not shown), which stores the computed values.

[0049] In addition to or alternatively to measuring the RF path length or delay, digital processing circuit may measure other signal characteristics, such as the amplitude of the reflected signals from the transition layer between ribs **34** and lung **28**. The amplitude of this reflection is typically stronger and differently shaped in patients suffering from pulmonary edema in comparison to healthier subjects. The signal amplitude and shape may also be fitted parametrically to a stratified model of the various tissues traversed by the RF waves, wherein the fit parameters include the fluid content.

[0050] Additionally or alternatively, circuit **46** may compute other parameters relating to tissue characteristics, such as the volume, shape, physical properties, locations and/or movement of structures in the path of the RF waves within the body. For example, the RF waves and signal processing carried out in front end **44** and circuit **46** may be adjusted to measure pericardial fluid content within mediastinum **30**. As another example, antennas **42** can be driven in a multi-static configuration to measure the electromagnetic properties of different sub-volumes within thorax **26**, and thus provide data that are spatially resolved in two or three dimensions. Such multi-static techniques (using extracorporeal antennas) are described, for example, in the above-mentioned WO 2011/067623 and US 2011/0130800, which also describe digital signal processing methods that can be used to compute the complex dielectric constants for the individual sub-volumes.

[0051] A communication interface **48** transmits and receives data to and from telemetry station **34** (FIG. 1) via a communication antenna **50**. The transmitted data typically comprise the indications of tissue characteristics that have been computed over time and stored by digital processing circuit **46**. These indications may include statistical parameters computed by circuit **46** over the tissue measurement results, such as time trend parameters of the measured fluid level. Alternatively or additionally, the indications of tissue characteristics may include raw data collected from front end **44**, and communication interface **48** may transmit data either intermittently or continuously as they are measured. Further alternatively or additionally, interface **48** may communicate with other implanted diagnostic and/or therapeutic devices, such as an intravascular pressure sensor or an ICD, or with non-invasive monitoring devices, such as a bio-impedance measurement device.

[0052] A power source **52** supplies operating power to the circuits of device **24**. Power source **52** typically comprises an energy storage component, such as a single-use or rechargeable battery. In the case of a rechargeable storage component, power source **52** may be coupled to a power antenna **54**, which receives RF power from a suitable power transmission antenna (not shown) outside the body. Alternatively, one or more of antennas **42** may additionally receive this RF power, instead of or in addition to power antenna **54**. The power transmission antenna may comprise, for example, a coil, which is positioned outside thorax **26** in proximity to device **24** and provides power to antenna **54** by magnetic induction. The power transmission coil may be placed under a mattress on which the patient lies, or it may be worn as a vest, a bra or

a necklace, for example. Power source **52** rectifies the received power in order to charge its energy storage component.

[0053] FIG. 4A is a schematic pictorial illustration of RF monitoring device **24**, in accordance with an embodiment of the invention, while FIG. 4B shows a schematic exploded view of the device of FIG. 4A. Case **40** comprises front and rear covers **62**, **64**, typically comprising titanium. Antennas **42** are printed, using hard gold or another suitable biocompatible conductor, on a main circuit board **66**, which typically comprises a biocompatible ceramic substrate to enable it to be hermetically sealed against covers **62** and **64**. Board **66** also has pads and conductors for mounting and connecting the components (not shown) of front end **44**, processing circuit **46**, and communication interface **48**. These components are typically embodied in one or more integrated circuits, as are known in the art. Front cover **62** comprises windows **60** containing antennas **42**, which are sealed by bonding the perimeters of the windows to brazing surrounding the antennas on board **66**.

[0054] Antennas **42** in this example each comprise a pair of printed conductive loops with a center feed, in an elliptic bowtie configuration. For enhanced efficiency and directionality, antennas **42** are backed by conductive air-filled cavities **68** on the side of board **66** opposite windows **60**. Cavity antennas of this sort (in an extracorporeal configuration) are described, for example, in the above-mentioned PCT International Publication WO 2011/067623. Alternatively, device **24** may comprise any other suitable type of antenna, such as a spiral, bowtie, or slotted antenna, with a cavity, electromagnetic bandgap (EBG) backing, or no backing.

[0055] Power antenna **54** comprises a coil **72** with a magnetic or ferritic core **74**, covered by a non-conductive biocompatible cover **78**. Coil **72** is connected via feed-throughs between covers **62** and **64** to power source **52**. Cover **78** typically comprises a suitable biocompatible plastic or other dielectric material, such as silicone molded over coil **72** and core **74**. Coil **72** may also serve as communication antenna **50**. Alternatively, a separate communication antenna **70** may be connected to board **66** and positioned to transmit and receive communication signals through a window **72** in cover **64**. As still another alternative, one or both of antennas **42** may serve as the communication antenna (although in this case it may be preferable that the antenna not have a cavity or other backing in order to strengthen the backlobe radiation transmitted by the antenna out of the body).

[0056] As noted earlier, device **24** comprises electrodes **56**, which are shown in FIGS. 4A and 4B as external elements on cover **62**. The ECG signals sensed by these electrodes may be used not only in synchronizing the measurements of RF reflections to the patient's heartbeat, but also as a diagnostic indicator in and of themselves, which is processed and stored by circuit **46**. This diagnostic indicator can then be used, for example, to detect cardiac arrhythmias, in a manner similar to a Holter monitor. Alternatively or additionally, device **24** can comprise sensors for other sorts of intra-body clinical measurements, such as temperature, blood pressure, and/or blood oxidation, thereby broadening the usefulness and improving the diagnostic accuracy of system **20**.

Alternative Embodiments

[0057] FIG. 5 is a schematic pictorial illustration of a monitoring system **80** comprising a RF monitoring device **82** implanted in a human body, in accordance with another

embodiment of the invention. Device **82** is similar in structure and function to device **24**, as described above, but in this embodiment, device **82** operates in conjunction with an internally-placed reflector **84** on the opposite side of the patient's lung, as shown in the figure, rather than relying on reflections from the heart. The use of a dedicated reflector strengthens the reflected waves that are received by device **82** and provides a constant physical path length to which the measured RF path length can be compared. Alternative placements of the monitoring device and reflector are shown in FIGS. **6A** and **6B**. As yet another alternative, the RF reflector may be positioned outside the patient's body.

[0058] Reflector **84** may be a passive structure made of biocompatible conducting material, or it may comprise one or more active components, which can be modulated to enhance signal extraction by device **82**. The modulation of this reflector can be triggered and powered externally by means of a magnetic pulse source or a low-frequency electromagnetic wave. As another alternative, an internal active or passive reflector of this sort can be used in conjunction with an external RF transmitter/receiver, in place of device **82**.

[0059] In an alternative embodiment, reflector **84** may be replaced by a RF transmitter, which transmits RF waves through the lung to device **82**. In this case, device **82** may comprise only a RF receiver (together with the processing circuitry and other components shown in FIG. **3**). As still another alternative, transmit/receive devices on opposite sides of the heart may each transmit RF waves and receive the RF waves transmitted by the counterpart device.

[0060] FIGS. **6A** and **6B** are schematic pictorial illustrations, in side and front views respectively, showing a system **90** in which a RF monitoring device **92** is implanted in a human body, in accordance with a further embodiment of the invention. In this embodiment, device **92** is similar in structure and function to device **24**, but is implanted in an inframammary location and operates in conjunction with a reflector **94** in a dorsal location, between the fourth and sixth ribs, for example. Alternatively, the locations of device **92** and reflector **94** may be reversed.

[0061] FIG. **6B** also shows an ICD **96**, which may be used in conjunction with device **92** or integrated with device **92**. For example, device **92** and pacemaker **96** may share a power source and/or communication circuits for communicating with station **34** outside the body. Device **92** and ICD **96** may even be contained in the same case, which may be implanted, for example, in the infra-mammary region. The measurements provided by device **92**, particularly with regard to the level of pulmonary fluid accumulation, may be used as an input in controlling the pacing of the heart by ICD **96**.

[0062] ICD **96** may alternatively serve as the reflector for device **92**, in place of reflector **94**. In this case, the ICD may simply be configured as a passive reflector, or it may comprise a modulated reflector, as described above.

[0063] FIG. **7** is a schematic pictorial illustration of a part of a RF monitoring device **100**, in accordance with another embodiment of the present invention. This figure shows the internal side of case **102** of device **100**, to which a cylindrical antenna support **104** is attached, by laser welding along a seam **106**, for example. A substrate **108** of the antenna is mounted on support **104**. Substrate **108** typically comprises a ceramic material, such as a low-temperature co-fired ceramic (LTCC), for example, Dupont 951LTCC. Substrate **108** comprises a metal coating around its perimeter, and is brazed to support **104** (as well as to the overlying front side of case **102**,

which is not shown in this figure) using a titanium ring **110** and a suitable filler material. The brazing serves the dual purposes of electromagnetically sealing the antenna to its backing and mechanically sealing the substrate to the case.

[0064] FIG. **8** is a schematic, partly-exploded view of a RF monitoring device **120**, in accordance with yet another embodiment of the present invention. In this embodiment, an antenna **124** is attached externally to a sealed case **122** of device **120**. Antenna **124** in this example comprises a conductive spiral **126**, but this sort of external configuration is equally applicable to other antenna types. Antenna **124** is inserted into a slot **128** in case **122**, and an edge **130** of the antenna is then sealed to case **122** by brazing, for example. The antenna is thus partially inside and partially outside the case, with sealed RF connections from the circuits inside the case to the outer antenna using printed electrical traces.

[0065] FIG. **9** is a schematic exploded view of antenna **124**, in accordance with an embodiment of the present invention. Antenna **124** comprises a stack of three layers, each on a respective ceramic substrate **132**, **134**, **138**. Spiral **126** is printed on the upper layer. An EBG structure **136** is printed on the middle layer, serving as a backing for spiral **126**, with EBG elements of different sizes corresponding to the different frequencies radiated by different areas of the spiral. The lower layer serves as a ground plane, with vias **140** passing through all the layers of antenna **124**. The vias are connected via leads (not shown) on substrate **138** to the circuits inside case **122**. The two central vias provide the signals for exciting spiral **126**.

[0066] FIG. **10** is a schematic pictorial illustration of a RF monitoring device **150**, in accordance with an additional embodiment of the present invention. Here a bowtie antenna **154** is connected by a coaxial cable **156** to circuits inside a case **152**. The cable and case are sealed by a feedthrough in a header **158**, which may comprise a suitable epoxy and/or polyurethane. Device **150** in this embodiment also has a communication antenna **160**, as described above.

[0067] As noted earlier, although the embodiments shown in the figures relate specifically to measurement of the fluid content of the lungs, the principles of the present invention may similarly be applied in monitoring of other organs, such as the heart, bladder, tongue, palate, spleen, brain, or body extremities. It will thus be appreciated that the embodiments described above are cited by way of example, and that the present invention is not limited to what has been particularly shown and described hereinabove. Rather, the scope of the present invention includes both combinations and subcombinations of the various features described hereinabove, as well as variations and modifications thereof which would occur to persons skilled in the art upon reading the foregoing description and which are not disclosed in the prior art.

1. Diagnostic apparatus, comprising:

a sealed case, comprising a biocompatible material and configured for implantation within a body of a human subject;

at least one antenna, which is configured to be implanted in the body in proximity to a target tissue and to receive radio frequency (RF) electromagnetic waves propagated through the target tissue and to output a signal in response to the received waves; and

processing circuitry, which is contained within the case and is coupled to receive and process the signal from the antenna so as to derive and output an indication of a characteristic of the target tissue.

2. The apparatus according to claim 1, wherein the at least one antenna is configured to transmit the waves into the body and to receive the transmitted waves following propagation of the waves through the target tissue.

3. The apparatus according to claim 2, wherein the at least one antenna is configured to receive the waves after reflection of the waves from a tissue in the body, and wherein the processing circuitry is configured to detect a modulation of the reflection due to at least one of a heartbeat and a respiratory motion of the subject.

4. The apparatus according to claim 3, wherein the modulation comprises a cyclical variation due to the heartbeat.

5. The apparatus according to claim 2, and comprising a reflector configured for implantation in the body in a location across the target tissue from the case containing the at least one antenna, wherein the reflector serves as the structure for reflecting the waves toward the at least one antenna.

6. The apparatus according to claim 5, wherein the reflector is a part of an implanted cardiac device (ICD) that is implanted in the body.

7. The apparatus according to claim 1, and comprising a transmitter, which is configured to be implanted in the body in a location across the target tissue from the case containing the at least one antenna and to transmit the waves through the target tissue.

8. The apparatus according to claim 1, wherein the processing circuitry is configured to process the signal so as to derive a measure of a fluid content of the target tissue.

9. The apparatus according to claim 8, wherein the case is configured for implantation in a thorax, and wherein the target tissue is lung tissue.

10. The apparatus according to claim 8, wherein the target tissue is spleen, liver, tongue or palate tissue.

11. The apparatus according to claim 1, wherein the indication comprises a time trend of the characteristic of the target tissue.

12. The apparatus according to claim 1, wherein the at least one antenna comprises a plurality of antennas.

13. The apparatus according to claim 12, wherein the processing circuitry is configured to drive the antennas in a multi-static mode so as to spatially resolve the characteristic of the target tissue.

14. The apparatus according to claim 1, wherein the at least one antenna is contained inside the case.

15. The apparatus according to claim 14, wherein the at least one antenna comprises a trace printed on a substrate, and wherein the case comprises a window, and the antenna is configured to receive the waves through the window.

16. The apparatus according to claim 15, wherein the substrate is sealed to the case by brazing.

17. The apparatus according to claim 1, wherein the at least one antenna is located partially outside the case and is connected to the processing circuitry via a sealed brazing to the case.

18. The apparatus according to claim 1, wherein the at least one antenna comprises a trace printed on a substrate and a backlobe suppression structure behind the trace.

19. The apparatus according to claim 18, wherein the backlobe suppression structure is selected from a group of structures consisting of an air cavity and an electromagnetic band-gap (EBG) backing.

20. The apparatus according to claim 1, wherein the at least one antenna is selected from a group of antenna types consisting of a spiral antenna, a bowtie antenna, an elliptic bowtie antenna, and a slotted antenna.

21.-48. (canceled)

* * * * *

专利名称(译)	植入式射频传感器		
公开(公告)号	US20130231550A1	公开(公告)日	2013-09-05
申请号	US13/811210	申请日	2011-07-21
[标]申请(专利权)人(译)	WEINSTEIN乌列尔 伯恩斯坦阿萨夫 COHEN EYAL OPPENHEIM DOV mosesko Moshe		
申请(专利权)人(译)	温斯坦乌列 伯恩斯坦, 阿萨夫 科恩EYAL OPPENHEIM, DOV MOSESKO, 摩西·		
[标]发明人	WEINSTEIN URIEL BERNSTEIN ASSAF COHEN EYAL OPPENHEIM DOV MOSESKO MOSHE		
发明人	WEINSTEIN, URIEL BERNSTEIN, ASSAF COHEN, EYAL OPPENHEIM, DOV MOSESKO, MOSHE		
IPC分类号	A61B5/0205 A61B5/00		
CPC分类号	A61B5/0028 A61B5/0205 A61B5/01 A61B5/0215 A61B5/0422 A61B5/05 A61B5/14542 A61B5/4875 A61B5/686 A61B2560/0219 A61N1/36521 A61N1/3702 A61N1/37229 A61N1/3756 A61B5/0538 A61B5/ /0059 A61B5/0031 A61B1/313 A61B5/0537 A61B5/076 A61B5/0809 A61B5/416 A61B5/4244 A61B5/ /4552 A61B5/6833 A61B5/72 A61B17/3468 A61B2562/0214 A61B2562/164		
优先权	61/366173 2010-07-21 US		
外部链接	Espacenet USPTO		

摘要(译)

诊断设备 (24) 包括密封壳体 (40), 其包括生物相容性材料并且被配置用于植入人体 (22) 的体内。至少一个天线 (42) 被配置为在身体中植入接近目标组织 (28) 并接收通过目标组织传播的射频 (RF) 电磁波并响应于接收到的波输出信号。包含在壳体内部的处理电路 (44,46) 被耦合以接收和处理来自天线的信号, 以便导出并输出目标组织的特征的指示。

