



(19) **United States**

(12) **Patent Application Publication**  
**Albu et al.**

(10) **Pub. No.: US 2012/0142999 A1**  
(43) **Pub. Date: Jun. 7, 2012**

(54) **ACTIVE PILLOW SYSTEM AND A METHOD FOR MANIPULATING A PERSON'S RESTING CONDITIONS**

(86) PCT No.: **PCT/IB10/52066**

§ 371 (c)(1),  
(2), (4) Date: **Feb. 27, 2012**

(75) Inventors: **Mirela Alina Albu**, Boukoul (NL);  
**Philip Steven Newton**, Eindhoven (NL);  
**Pedro Fonseca**, Antwerpen (BE);  
**Dmitry Chestakov**, Eindhoven (NL);  
**Jia Du**, Eindhoven (NL);  
**Vincentius Paulus Buil**, Eindhoven (NL);  
**Liesbeth Scholten**, Amsterdam (NL);  
**Serverius Petrus Paulus Pronk**, Vught (NL);  
**Fiona Rees**, Eindhoven (NL)

(30) **Foreign Application Priority Data**

May 13, 2009 (EP) ..... 09160160.9

**Publication Classification**

(51) **Int. Cl.**  
*A61M 21/00* (2006.01)  
*A61B 5/00* (2006.01)  
*A47G 9/10* (2006.01)

(52) **U.S. Cl.** ..... **600/26; 5/636**

(57) **ABSTRACT**

The present invention relates to an active pillow system and a method for manipulating a person's resting conditions, wherein the actual resting conditions of the person are determined by a sensor unit, an actigraph, a temperature sensor and/or a humidity sensor for instance, and wherein an acoustic synthetic jet cooling mechanism, is triggered by the determined actual resting conditions for manipulating the person's resting conditions.

(73) Assignee: **KONINKLIJKE PHILIPS ELECTRONICS N.V.**, EINDHOVEN (NL)

(21) Appl. No.: **13/320,032**

(22) PCT Filed: **May 11, 2010**

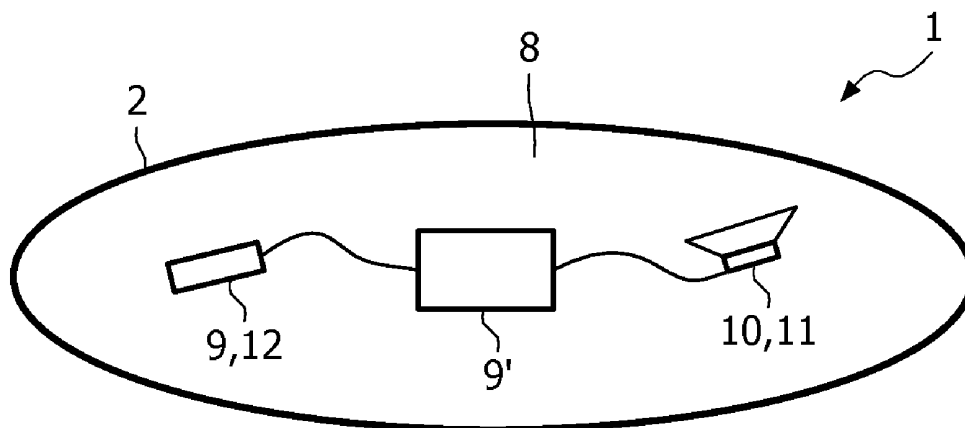

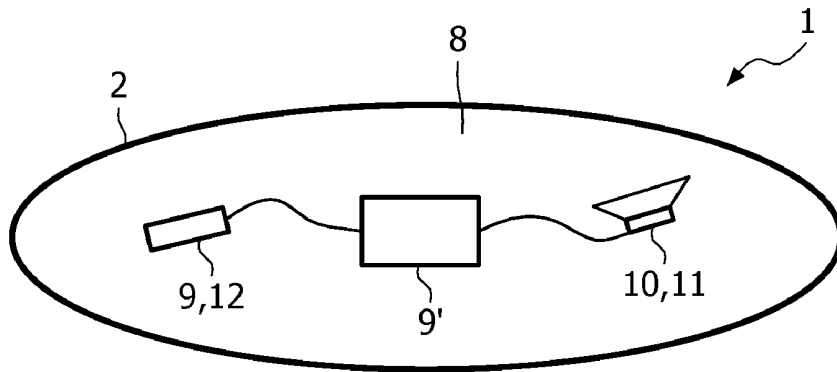

FIG. 1

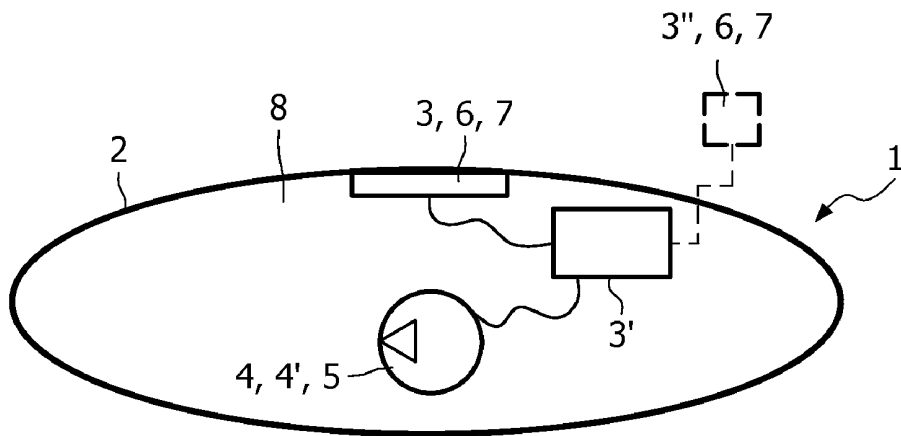

FIG. 2

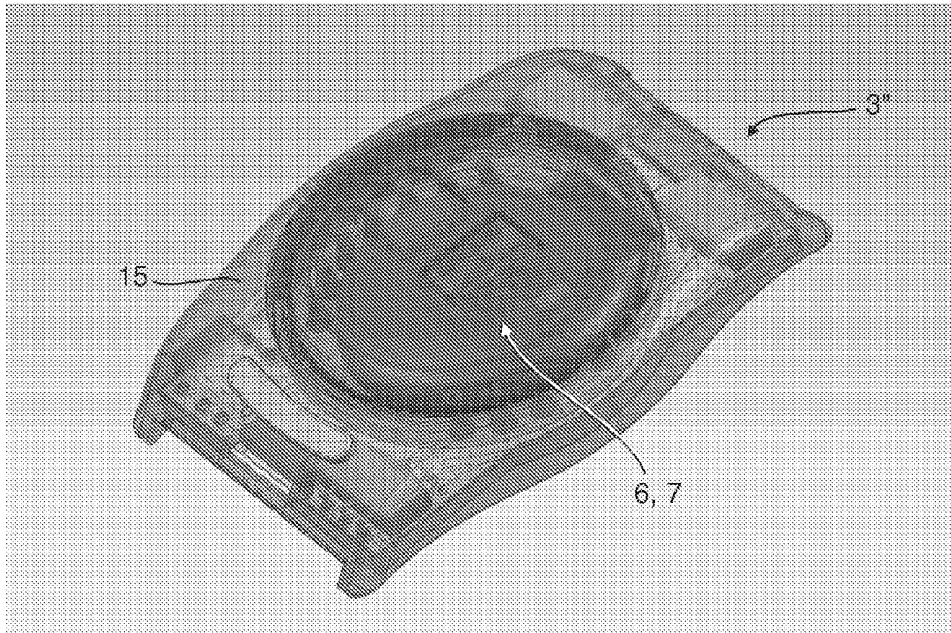

FIG. 3a

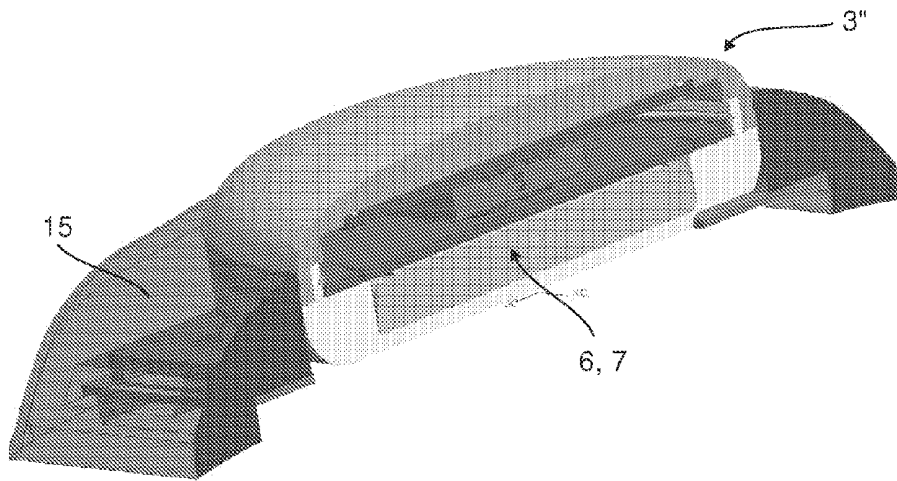

FIG. 3b

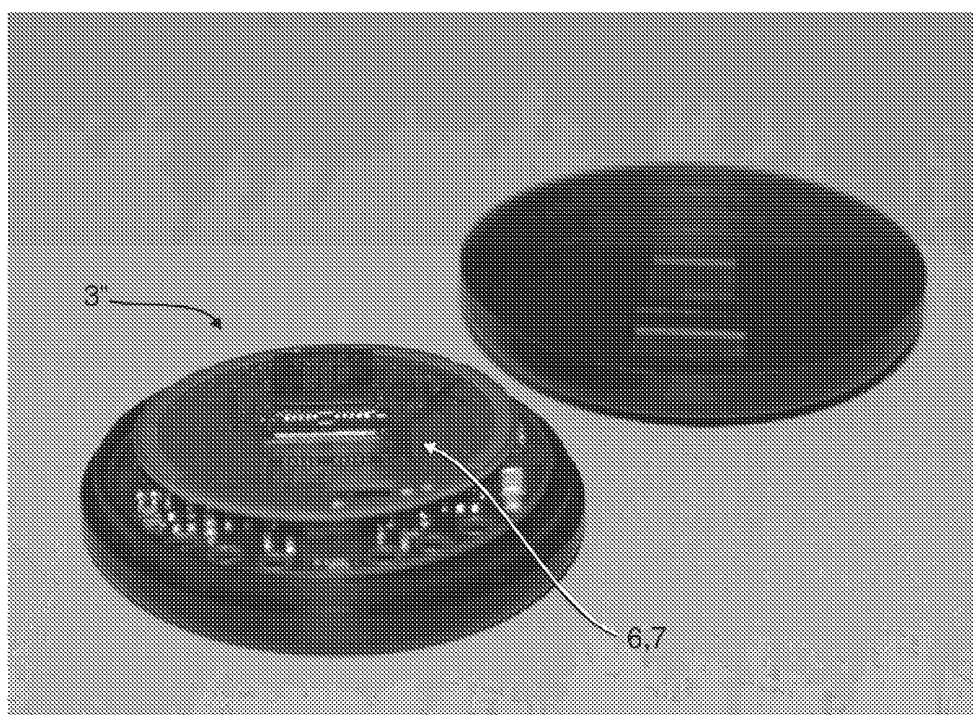

FIG. 4

## ACTIVE PILLOW SYSTEM AND A METHOD FOR MANIPULATING A PERSON'S RESTING CONDITIONS

### FIELD OF THE INVENTION

[0001] The present inventions relates to the field of sleep monitoring and active sleep manipulation.

### BACKGROUND OF THE INVENTION

[0002] During the summer, because of the high temperature, the pillow of a sleeping person can become very hot and humid from perspiration. Due to this reason many people sleep uncomfortably and sometimes even wake up and turn the pillow to benefit from the colder/dry side.

[0003] The state of the art in cooling pillows consists of mostly water based solutions. In most of these solutions the cooling is achieved by filling a hermetic container with water, and placing it in the fridge for a while before use. The container is to be placed afterwards in the pocket of the pillow case and after which the case is slipped over the pillow. By means of the heat exchange process the heat is released it into the air. A great disadvantage of this solution is that the water in the pillow must be changed manually which is very cumbersome. Simultaneously, the low temperature of the cold pack will lead to condensation which will make the pillow wet giving an unpleasant feeling which could actually disturb the sleep more than when the cooling is not used. Further, the prior art document WO 2009/005 616 A1 discloses a multiple convective cushion seating and sleeping system incorporating a blower and a stirling cycle to provide temperature modified air which is controllably guided through first and second conductive cushions. Disadvantageously, the integration of a total stirling cycle in a pillow is very difficult, expensive and therefore highly impractical. Another cooling pillow solution disclosed by the patent application WO 00/06006 A1 is based on the principle that the air is made to flow in close contact with the fibrous material being in the vicinity of the body of the user and containing a sufficient amount of water, vaporization of water is promoted, and the head is cooled by absorbing the heat of vaporization. These inventions therefore have an air sending fan, a flow passage through which the air is made to flow, and a vaporization sheet forming the flow passage and containing water. A great disadvantage of this solution is the usage of a fan, which needs a large rotational speed of the rotor to become effective and therefore leads to undesirable noise and vibrations in the pillow.

[0004] Currently, on the market, more and more products support people to relax and fall asleep in bed without disturbing their partners. This concept often can be found in different kinds of pillows. For example, pillows with integrated speakers that produce relaxed soothing music and help block environmental noises by creating white noises closely around a person's ears are known. Such products are ideal for private use and travelers due to its portability. There are also pillows with integrated light, which illuminates its surface gradually in the morning to bring a pleasant waking up experiences to a person while keeping the partners asleep. Furthermore, the prior art document WO 2004/75 714 A2 discloses a system for manipulating sleep architecture by sub-awakening non-intrusive stimulations based on a real-time, self-adaptive feedback system including a sleep and environment monitoring unit, an integrating, controlling and deciding unit and a stimulation unit. Disadvantageously, this prior art document

does not disclose the monitoring of the sleeping person by the aid of an actimetry sensor which provides a very low-cost, compact and accurate determination of the actual sleeping conditions of the sleeping person.

### SUMMARY OF THE INVENTION

[0005] It is an object of the present invention to provide an active pillow system for manipulating a person's resting conditions which comprises a feed back high-performance and low-noise air conditioner and does not have the drawbacks mentioned in connection with the prior art.

[0006] The above mentioned object is accomplished by an active pillow system for manipulating a person's resting conditions comprising:

[0007] a sensor unit and

[0008] an air conditioner unit triggered by the sensor unit,

[0009] wherein the air conditioner unit comprises an acoustic synthetic jet cooling mechanism.

[0010] Advantageously, the generation of an acoustic synthetic jet with the aid of an acoustic synthetic jet cooling mechanism is much more quiet compared to a fan based water evaporation cooling solution according to the above mentioned state of the art. The usage of the acoustic synthetic jet principle is proposed to control the amount of airflow through air channels in the pillow. The airflow will increase evaporation of sweat that accumulates in the pillow during sleeping or resting of the person. The main effect of the evaporation is to dry the pillow, making it feel more comfortable during the night. In addition as side effect it will help to control the temperature of the pillow.

[0011] The acoustic synthetic jet cooling mechanism comprises a diaphragm pump and particularly a loudspeaker, for instance. It is a great advantage of the active pillow system that the acoustic synthetic jet cooling mechanism is able to generate a strong airflow on the one hand, but it does not require a fast rotational movement of a rotor on the other hand. Therefore, aerodynamic noise, vibrations, abrasions and grinding noises caused by the moving rotor can be avoided. This is very important as the active pillow system is provided to improve the person's resting or sleeping conditions and must not be a disturbance source for the resting or sleeping person. In particular, if the person's head lies on the pillow typically with a small distance to the air conditioner. In this active pillow system the air conditioner consists of a loudspeaker in a chamber through a special construction in the chamber a by applying certain frequencies an airjet is produced that can be used to cool devices. It is shown that the acoustic synthetic jet cooling method allows miniaturization, it is very reliable because it has only one moving part that is frictionless driven by a magnetic field. This in contrast to other cooling based methods based on water such as pumps or airflow such as fans. The term "resting" in the sense of the present inventions includes relaxing, as well as sleeping, recovering, regeneration and/or rehabilitation of the person. The wording "pillow" can be understood as a head cushion, a mattress, a sofa cushion, a blanket, a seat cover or the like. Preferably, the acoustic synthetic jet cooling mechanism comprises a membrane which is operated by an electromagnetic and/or a piezoelectric driver.

[0012] The sensor unit measures the actual resting conditions of the person. Based on the data collected by the sensor unit the temperature of the pillow is gently adjusted, in particular by a processing unit, to prevent the person to overheat

and perspire during hot seasons, for example. Preferably, the sensor unit measures the temperature and/or the humidity of the person and/or the sensor unit measures the temperature and/or the humidity in the environment of the person. Subsequently, the air conditioner is triggered, if required, to improve the climatic conditions to enhance the person's resting conditions. Consequently, the sensor unit incorporates a feedback path for the active pillow system for adjusting optimal resting conditions for the resting person.

**[0013]** In a preferred embodiment the active pillow system according to the present invention comprises a user interface which is wireless connected to the active pillow system, for instance, and allows the resting person to determine individual favored resting conditions. The person can adjust a target temperature value, a target humidity value and/or a target airflow value, for example. Furthermore, the target temperature value, the target humidity value and/or the target airflow value can be chosen in dependency of time, in particular the resting time, or in dependency of the sleeping phase. The temperature of the pillow can be lowered during REM (Rapid Eye Movement) phases and increased in the early morning shortly before getting up, for instance.

**[0014]** In a preferred embodiment the sensor unit and/or the air conditioner unit is encased into a cushion material to increase the softness of the surface of the active pillow system to improve the resting comfort. Preferably, the cushion material comprises a memory foam material which provides an individual ergonomic pillow shape.

**[0015]** Another object of the present invention is an active pillow system for manipulating a person's resting conditions comprising:

**[0016]** an actigraph for determining the person's resting status and

**[0017]** an actuator unit for manipulating the person's resting conditions triggered by the actigraph. Beneficially, the actigraph measures body movements of the person and/or a body motion pattern of the person to determine the actual sleeping depth, the sleeping phase, the relaxation level, the sleep pattern and/or the circadian rhythms of the person, for instance. The actuator comprises a stimulation device integrated into the pillow for manipulating the person's resting status by emitting light, sound, vibrations, electromagnetic waves, flavored air, heat, cooling air and the like, for instance. Preferably, the actigraph comprises an acceleration sensor, a force sensor, a pressure sensor or a strain gauge which is integrated into the active pillow system and measures the movement of the surface of the pillow caused by body motions of the person's head, for instance. In another embodiment the actigraph is attached directly to the resting person, preferably by an adhesive tape, a body strip, a head strip or a wrist strip. In this case, a hardwired or a wireless communication between the actigraph and the actuator unit integrated into the pillow is possible. Accordingly, the active pillow system measures some user parameters and provides certain stimulation back to user for the relaxation or stimulation purposes by a processing unit. Preferably, it automatically starts treatment when stress detected (when enabled), wherein the intensity of the treatment is based on stress derivatives measured. The treatment can also stop automatically, when the person is fully relaxed or sleeping. The parameters of the active pillow system

are adjustable by the person via a user-interface preferably wireless connected to the actuator, the processing unit and/or the actigraph.

**[0018]** Particularly, the acceleration sensor comprises a piezoelectric accelerometer and a low-pass band filter that filters out higher frequencies to eliminate signals caused by external vibrations. The actigraph preferably incorporates zero crossing mode (ZCM: counting the number of times the accelerometer waveform crosses zero for each time period), proportional integral mode (PIM: measuring the area under the curve and adding that size for each period), as well as time above threshold mode (TAT: using a certain threshold and measuring the length of time that the wave is above a certain threshold).

**[0019]** Furthermore, the active pillow system and/or the sensor unit measures physiological parameters of the person, like pulse rate, electrical activity of the person's brain (EEG), electrical activity of the person's heart (ECG), activation signals of the person's muscles (EMG), galvanic skin response (GSR) and the like. Subsequently, the active pillow system determines the actual resting conditions of the person, like the sleeping depth, the sleeping phase and/or the relaxation level both from the actigraphy measurements and from the physiological parameters to improve the accuracy of the detection.

**[0020]** Another object of the present invention is a method for manipulating a person's resting conditions comprising the steps of:

**[0021]** measuring the movement of the person by actigraphy measurements,

**[0022]** determining the person's resting status in dependency of the measured movement of the person,

**[0023]** generating a feedback signal in dependency of the determined person's resting status for manipulating the person's resting conditions.

**[0024]** Another object of the present inventions is a method for manipulating a person's resting conditions comprising the steps of:

**[0025]** determining actual climatic conditions and

**[0026]** triggering a loudspeaker for generating an acoustic synthetic jet cooling in dependency of the determined climatic conditions.

**[0027]** These and other characteristics, features and advantages of the present invention will become apparent from the following detailed description, taken in conjunction with the accompanying drawing, which illustrates, by way of example, the principles of the invention. The description is given for the sake of example only, without limiting the scope of the invention. The reference figures quoted below refer to the attached drawing.

#### BRIEF DESCRIPTION OF THE DRAWINGS

**[0028]** FIG. 1 shows an active pillow system according to a first embodiment of the present invention;

**[0029]** FIG. 2 shows an active pillow system according to a second embodiment of the present invention;

**[0030]** FIGS. 3a, 3b shows a sensor unit of an active pillow system according to the second embodiment of the present invention and

[0031] FIG. 4 shows a sensor unit of an active pillow system according to a third embodiment of the present invention.

#### DETAILED DESCRIPTION OF EMBODIMENTS

[0032] The present invention will be described with respect to particular embodiments and with reference to a certain drawing but the invention is not limited thereto but only by the claims. The drawing described is only schematic and is non-limiting. In the drawing, the size of some of the elements may be exaggerated and not drawn on scale for illustrative purposes.

[0033] Where an indefinite or definite article is used when referring to a singular noun, e.g. "a", "an", "the", this includes a plural of that noun unless something else is specifically stated. Furthermore, the terms first, second, third and the like in the description and in the claims are used for distinguishing between similar elements and not necessarily for describing a sequential or chronological order. It is to be understood that the terms so used are interchangeable under appropriate circumstances and that the embodiments of the invention described herein are capable of operation in other sequences than described or illustrated herein. Moreover, the terms top, bottom, over, under and the like in the description and the claims are used for descriptive purposes and not necessarily for describing relative positions. It is to be understood that the terms so used are interchangeable under appropriate circumstances and that the embodiments of the invention described herein are capable of operation in other orientations than described or illustrated herein. It is to be noticed that the term "comprising", used in the present description and claims, should not be interpreted as being restricted to the means listed thereafter; it does not exclude other elements or steps. Thus, the scope of the expression "a device comprising means A and B" should not be limited to devices consisting only of components A and B. It means that with respect to the present invention, the only relevant components of the device are A and B.

[0034] FIG. 1 shows a schematic illustration of an active pillow system 1 according to a first embodiment of the present invention. The active pillow system 1 comprises a pillow 2 with an actigraph 9, a processing unit 9' and an actuator unit 10 inside. The actigraph comprises an acceleration sensor 12 for determining the resting status of a person using the pillow 2. The acceleration sensor 12 measures body movements of the person and the processing unit 9', which preferably is a part of the actigraph 9, analyzes the measured signals of the acceleration sensor 12 and interpret the movement pattern of the person to determine the actual person's sleeping depth, sleeping phase or the like. Subsequently, the processing unit 9' generates feedback signals in dependency of the determined sleeping depth, sleeping phase or the like, which were processed by the actuator unit 10. In the present example, the actuator unit 10 comprises a further loudspeaker 11 for playing back music or single tones to the person. If an awake state of the person in the later evening or during nighttime is detected by the actigraph 9, the actuator unit 10 plays back relaxing and soothing music or tones to send the person to sleep, for instance. Preferably, the loudspeaker 11 plays back monotonous tones or nature sounds, like singing birds, sounds of the sea, crushing waves or the like. In the meantime, the actigraph 9 continuously monitors the actual resting conditions of the person and stops or fades out the playback of the loudspeaker 11, when the person fall asleep (again), for example. In another embodiment, the actuator unit 10 com-

prises a light source which illuminates the surface of the pillow 2 in the morning during wake up time to bring a pleasant waking up experiences to the person; in the case the actigraph detects 9 an actual depth sleeping phase of the person, for instance. In another embodiment the active pillow system is integrated into a couch and provides the person using the couch with relaxing sounds or music improving the relaxation and the regeneration of the person, but also monitoring his reaction and resting conditions at the same time to adapt the play back of the relaxing sounds or music to the behavior and the resting conditions of the person.

[0035] FIG. 2 shows a schematic illustration of an active pillow system 1 according to a second embodiment of the present invention. The active pillow system 1 comprises a pillow 2 with a sensor unit 3 and an air conditioner unit 4 inside. The sensor unit 3 measures the actual climatic conditions near the surface of the pillow 2, which is preferably in contact with a head of a person using the pillow 2. The sensor unit 3 incorporates a temperature sensor 6 for measuring the temperature of the head or of the surface of the pillow 2, a humidity sensor for measuring the humidity on the surface of the pillow 2 and/or a galvanic skin response (GSR) sensor 7 for measuring electric conductance of the skin of the person to determine the perspiration of the person. The measured values are used to give an indication about the person's body temperature and humidity and therefore are analyzed by a processing unit 3', which is a part of the sensor unit 3, to determine the actual climatic conditions of the person. In dependency of these determined actual climatic conditions the air conditioner unit 4 is triggered by the processing unit 3' to provide optimal climatic conditions to the person. If the temperature of the pillow 2 or of the head of the person exceeds a certain threshold, the air conditioner 4 starts to cool down the surface of the pillow 2 by airflow and if the temperature falls below another threshold, the air conditioner 4 stops cooling, for instance. Therefore, the air conditioner 4 comprises an acoustic jet cooling mechanism 4', wherein the airflow is provided by an oscillating membrane and not by a rotating impeller. In this active pillow system 1 the air conditioner 4 consists of a loudspeaker 5 in a chamber through a special construction in the chamber a by applying certain frequencies an airjet is produced that can be used to cool devices. The noise produced by such a system is less than a regular fan based solution and could be further reduced by sound proofing the device. In this study it is shown that the acoustic synthetic jet cooling method allows miniaturization, it is very reliable because it has only one moving part that is frictionless driven by a magnetic field. This in contrast to other cooling based methods based on water such as pumps or airflow such as fans.

[0036] In another preferred embodiment the processing unit 3' is wireless connected to a further sensor unit 3'' which is directly attached to the body of the person by a wristband of a wrist watch. The further sensor unit 3'' comprises a temperature sensor 6, a galvanic skin sensor 7 and a pulse sensor. The sensor unit 3'' is integrated into the housing 15 of a wrist watch, for example, which straight contacts the skin of the person. The housing 15 of the wrist watch and the further sensor unit 3'' are schematically illustrated in FIGS. 3a and 3b.

[0037] FIG. 4 shows a sensor unit 3 of an active pillow system according to a third embodiment of the present invention, wherein the sensor unit 3 comprises a 3D accelerometer as well which can be used to detect user restlessness during

the sleep. The whole module has 35 mm in diameter, weighs 13.5 g and it comes equipped with a 60 mAh 3.7V Lithium rechargeable battery which enables a full day of use. The device could alternatively be equipped with a rechargeable battery such as a lithium polymer type that is recharged by placing the pillow on a surface that has an embedded coil, through induction in a corresponding coil in the pillow the battery is charged. Therefore the sensor unit 3 comprises a printed antenna on his topside. The pillow 2 temperature can be measured by temperature sensors 6 such as thermocouples or semiconductors temperature sensors. The advantage of the latter is that they are quite small, accurate and inexpensive.

1. An active pillow system (1) for manipulating a person's resting conditions comprising:

a pillow (2)

a sensor unit (3) and

an air conditioner (4) unit triggered by the sensor unit (3), wherein the air conditioner unit (4) is integrated into the pillow (2) and comprises an acoustic synthetic jet cooling mechanism (4').

2. An active pillow system (1) according to claim 1, characterized in that the synthetic jet cooling mechanism (4') comprises a loudspeaker (5) and/or a diaphragm pump.

3. An active pillow system (1) according to claim 1, characterized in that the sensor unit (3) comprises a humidity sensor, a temperature sensor (6) and/or a galvanic skin response sensor (7).

4. An active pillow system (1) according to claim 1, characterized in that the sensor unit (3) and/or the air conditioner unit (4) are encased into a cushion material (8) of the pillow (2), in particular a foam material.

5. An active pillow system (1) according to claim 4, characterized that a interlayer is assembled between the cushion material (8) on the one hand and the sensor unit (3) and/or the air conditioner unit (4) on the other hand, wherein the cushion material is more flexible than the interlayer.

6. An active pillow system (1) according to claim 3, characterized in that the foam material and/or the interlayer comprise multiple air ventilation ducts.

7. An active pillow system (1) for manipulating a person's resting conditions comprising:

an actigraph (9) for determining the person's resting status and

an actuator unit (10) for manipulating the person's resting conditions triggered by the actigraph (9).

8. An active pillow system (1) according to claim 7, characterized in that the actigraph (9) comprises an acceleration sensor (12), a force sensor, a pressure sensor and/or a strain gauge.

9. An active pillow system (1) according to claim 7 characterized in that the active pillow system (1) further comprises a temperature sensor, a galvanic skin response sensor, an electrocardiograph, electroencephalograph, a pulse monitor, a microphone, a snoring detector, a breathing detector and/or a light sensor.

10. An active pillow system (1) according to claim 7 characterized in that the actuator unit (10) comprises a fan, a further loudspeaker (11), a light source, an air freshener, an air conditioner, a heating device, a vibrator and/or an electromagnetic emitter.

11. A method for manipulating a person's resting conditions comprising the steps of:

measuring the movement of the person by actigraphic measurements,

determining the person's resting status in dependency of the measured movement of the person,

generating a feedback signal in dependency of the determined person's resting status for manipulating the person's resting conditions.

12. A method according to claim 11, characterized in that generating a feedback signal comprises the step of emitting sound, light, vibrations, electromagnetic waves, flavored air, heat and/or cooling air.

13. A method for manipulating a person's resting conditions comprising the steps of:

determining actual climatic conditions and

triggering a loudspeaker (5) for generating an acoustic synthetic jet in dependency of the determined climatic conditions.

14. A method according to claim 13, characterized in that the step of measuring the climatic conditions comprises a step of measuring the temperature and/or the galvanic skin response of the person, in particular in the environment of the person's head.

15. A method according to claim 13, characterized in that the step of measuring the climatic conditions comprises a step of measuring the temperature and/or the humidity in the environment of the person and in particular measuring the temperature and/or the humidity of a pillow (2) used by the person.

\* \* \* \* \*

专利名称(译)	主动枕头系统和操纵人的休息条件的方法		
公开(公告)号	<a href="#">US20120142999A1</a>	公开(公告)日	2012-06-07
申请号	US13/320032	申请日	2010-05-11
[标]申请(专利权)人(译)	皇家飞利浦电子股份有限公司		
申请(专利权)人(译)	皇家飞利浦电子N.V.		
当前申请(专利权)人(译)	皇家飞利浦电子N.V.		
[标]发明人	ALBU MIRELA ALINA NEWTON PHILIP STEVEN FONSECA PEDRO CHESTAKOV DMITRY DU JIA BUIL VINCENTIUS PAULUS SCHOLTEN LIESBETH PRONK SERVERIUS PETRUS PAULUS REES FIONA		
发明人	ALBU, MIRELA ALINA NEWTON, PHILIP STEVEN FONSECA, PEDRO CHESTAKOV, DMITRY DU, JIA BUIL, VINCENTIUS PAULUS SCHOLTEN, LIESBETH PRONK, SERVERIUS PETRUS PAULUS REES, FIONA		
IPC分类号	A61M21/00 A61B5/00 A47G9/10		
CPC分类号	A47G9/0215 A47G9/1036 A61B5/0002 A61B5/01 A61B5/7203 A61B5/4806 A61B5/4809 A61B5/4812 A61B5/6887 A61B5/1118 A47G2200/066 A47G2200/085 A47G2200/146 A47G2200/166 A47G2200 /205 A61H23/02		
优先权	2009160160 2009-05-13 EP		
外部链接	<a href="#">Espacenet</a> <a href="#">USPTO</a>		

摘要(译)

活动枕头系统和用于操纵人的休息状态的方法技术领域本发明涉及一种活动枕头系统和用于操纵人的休息状态的方法，其中人的实际休息状况由例如传感器单元，活动记录仪，温度传感器和/或湿度传感器确定。并且其中声学合成射流冷却机构由所确定的用于操纵人的静止状态的实际静止状态触发。

