



US 20070078309A1

(19) **United States**

(12) **Patent Application Publication**
Matlock

(10) **Pub. No.: US 2007/0078309 A1**

(43) **Pub. Date: Apr. 5, 2007**

(54) **OPTICALLY ALIGNED PULSE OXIMETRY
SENSOR AND TECHNIQUE FOR USING THE
SAME**

Publication Classification

(51) **Int. Cl.**
A61B 5/00 (2006.01)

(52) **U.S. Cl.** 600/310

(76) **Inventor: George L. Matlock, Pleasanton, CA
(US)**

Correspondence Address:
**FLETCHER YODER (TYCO
INTERNATIONAL, LTD.)
P.O. BOX 692289
HOUSTON, TX 77269-2289 (US)**

(57) **ABSTRACT**

A physiological sensor is provided that includes an emitter and detector disposed on a frame such that the emitter and detector define an optical axis. The frame includes one or more pair of flexible elements disposed generally symmetric relative to the optical axis. In one embodiment, the emitter and detector remain aligned when moved relative to one another along the optical axis.

(21) **Appl. No.: 11/241,031**

(22) **Filed: Sep. 30, 2005**

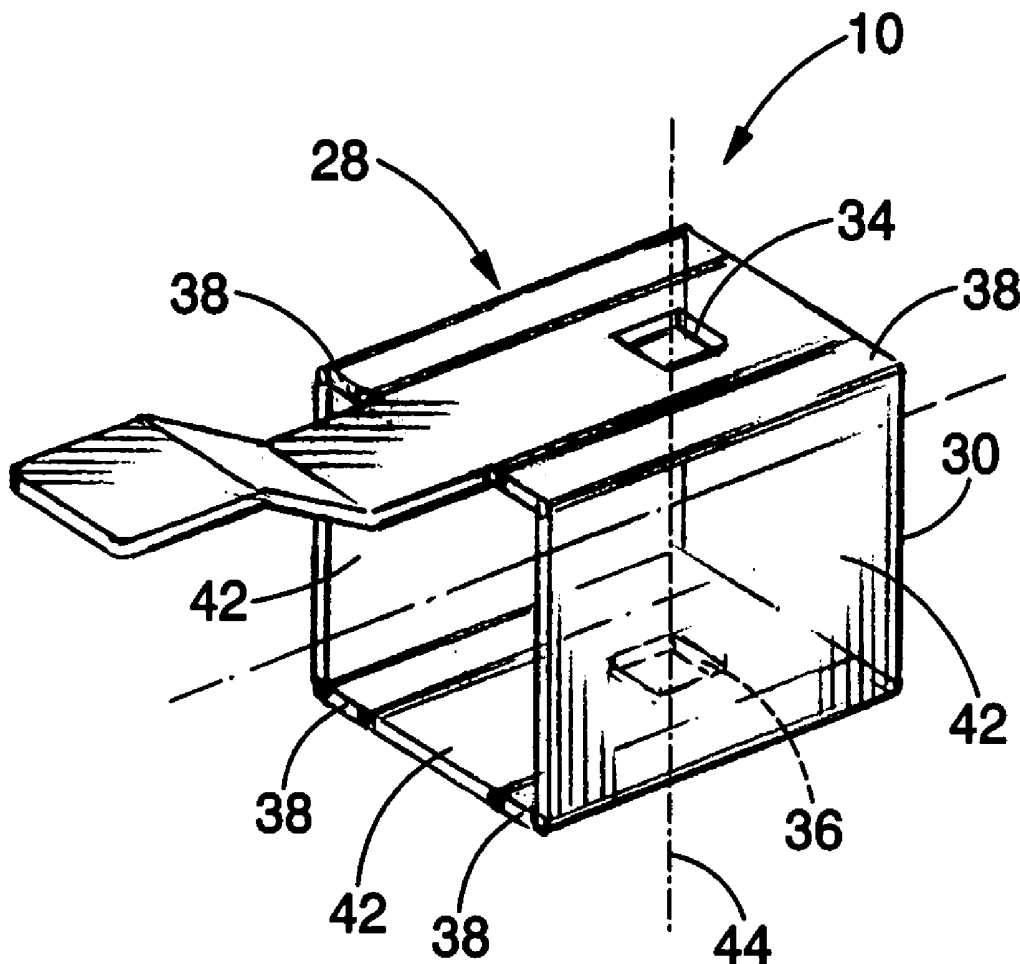

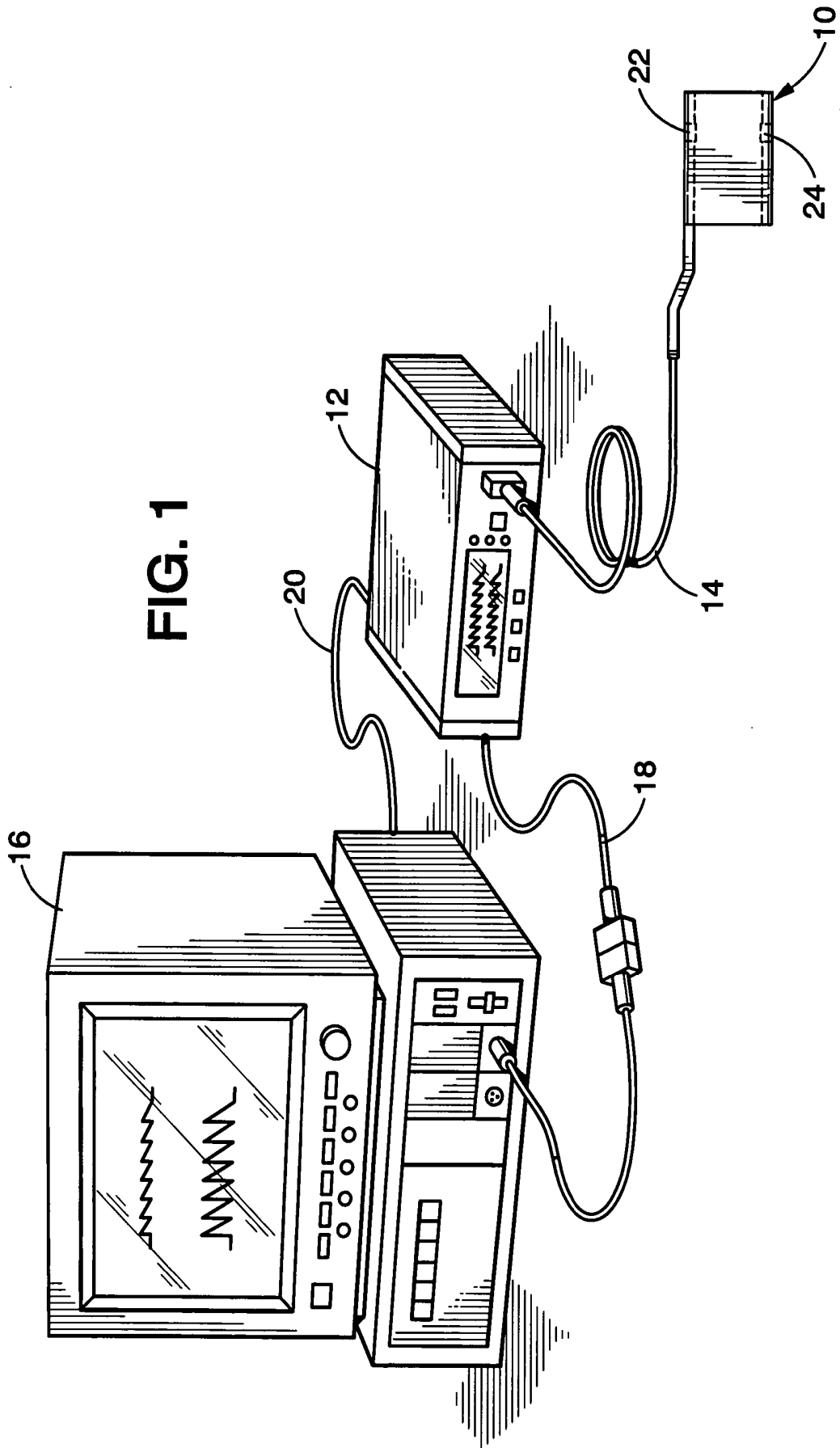

FIG. 2

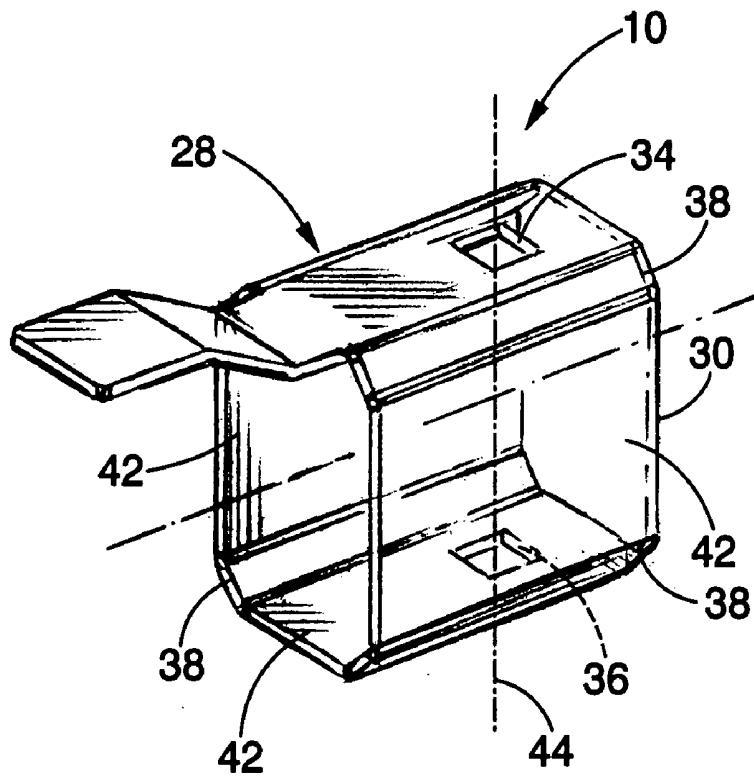
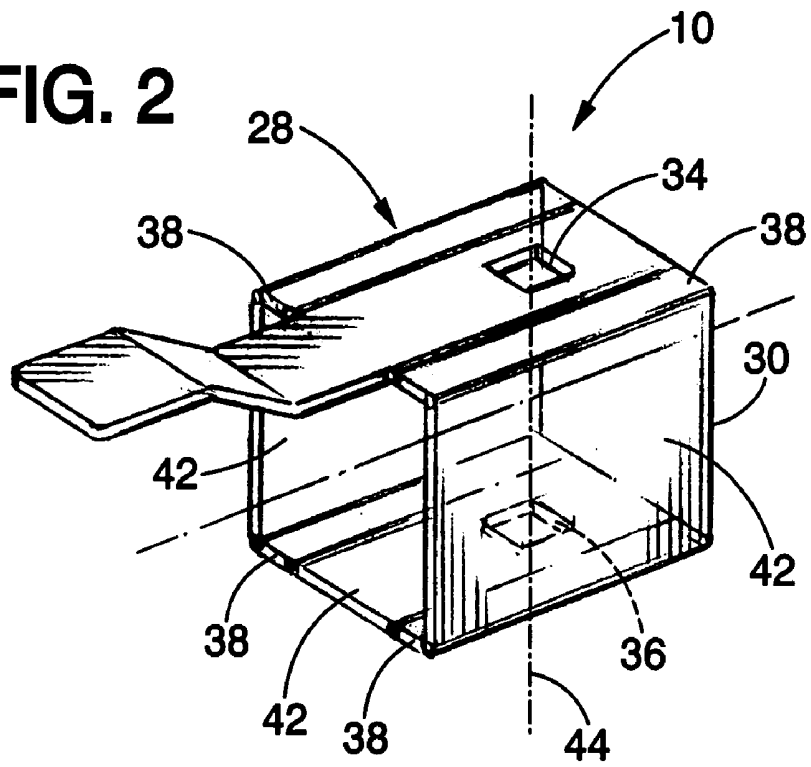

FIG. 3

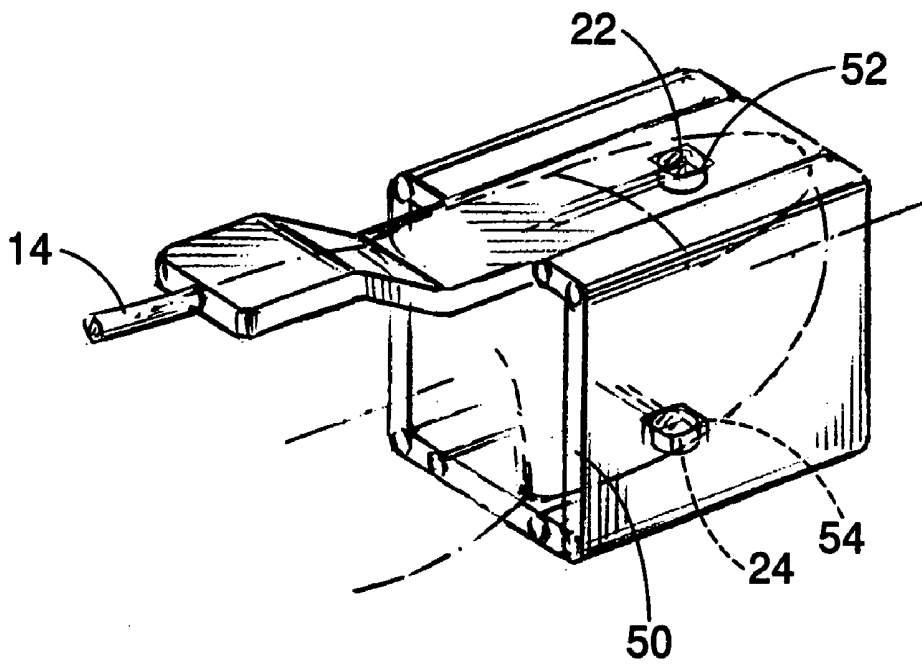
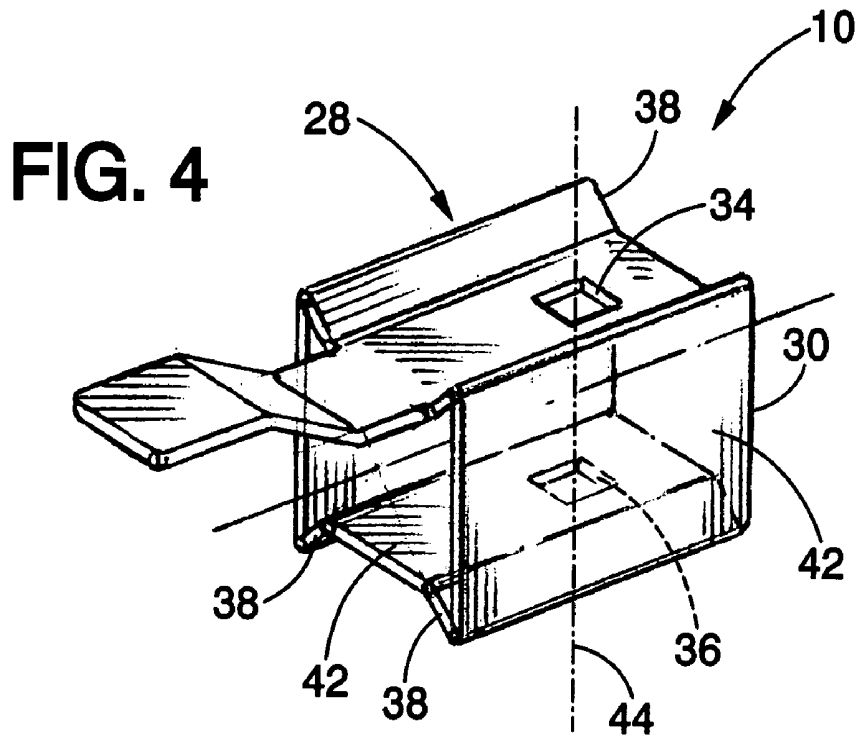

FIG. 5

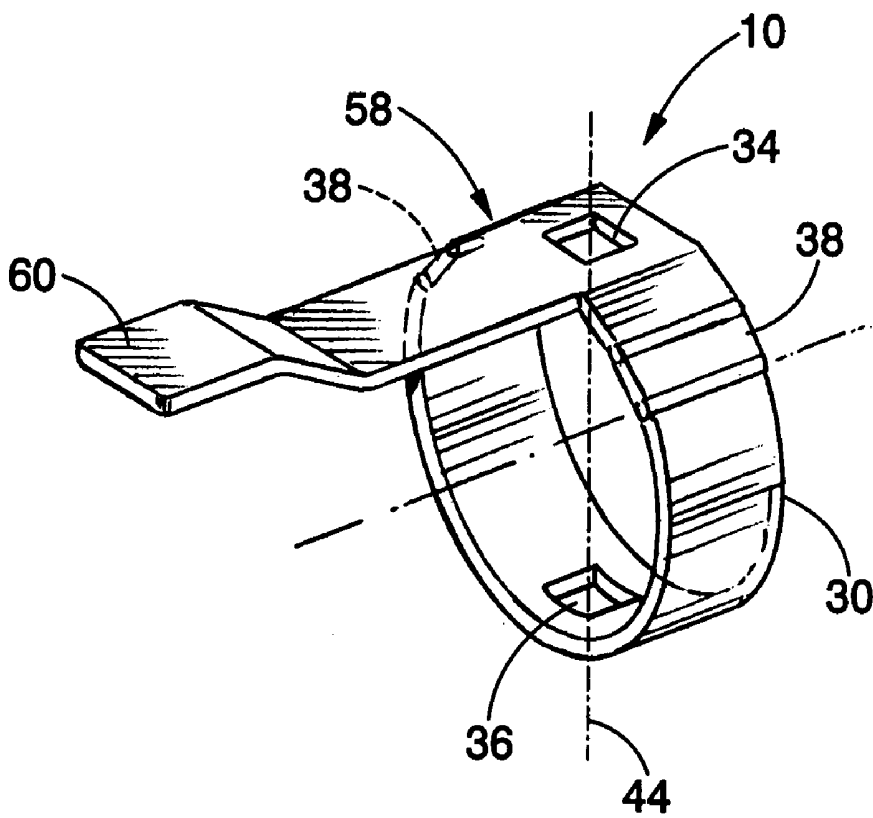
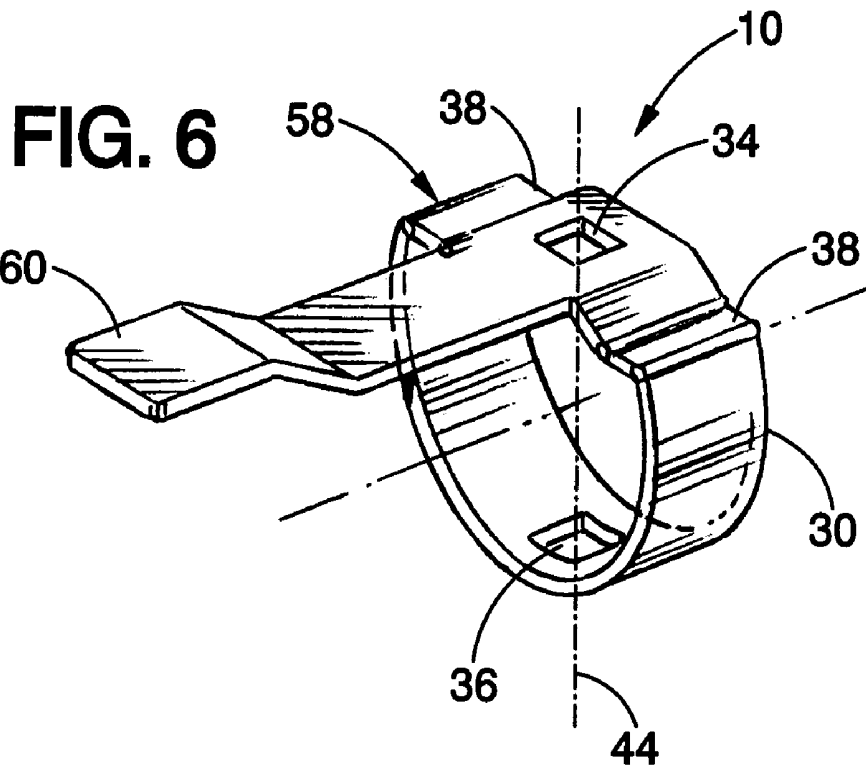

FIG. 7

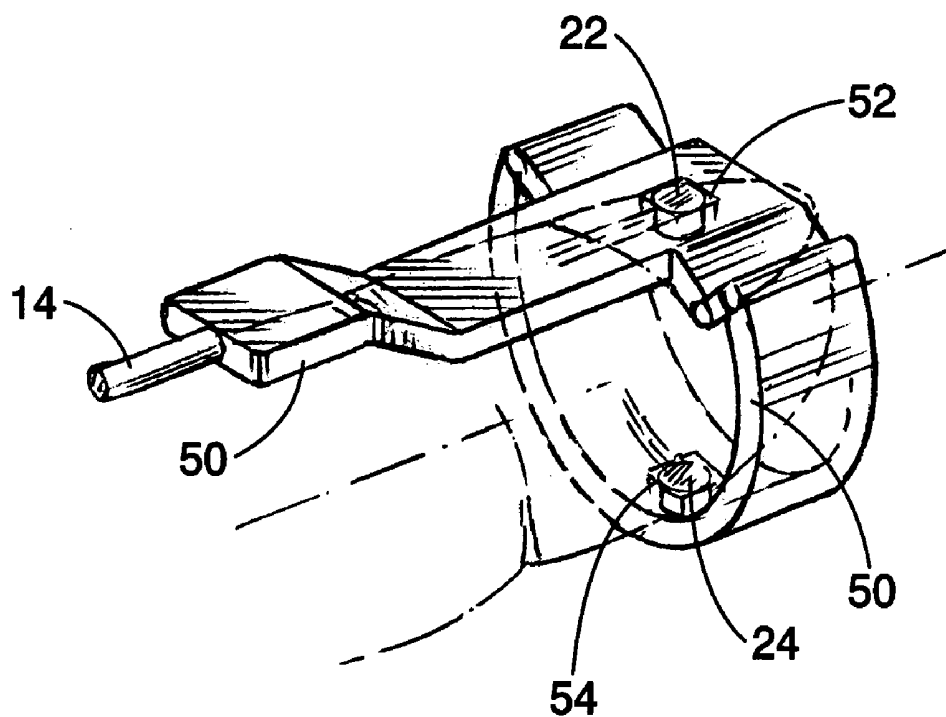
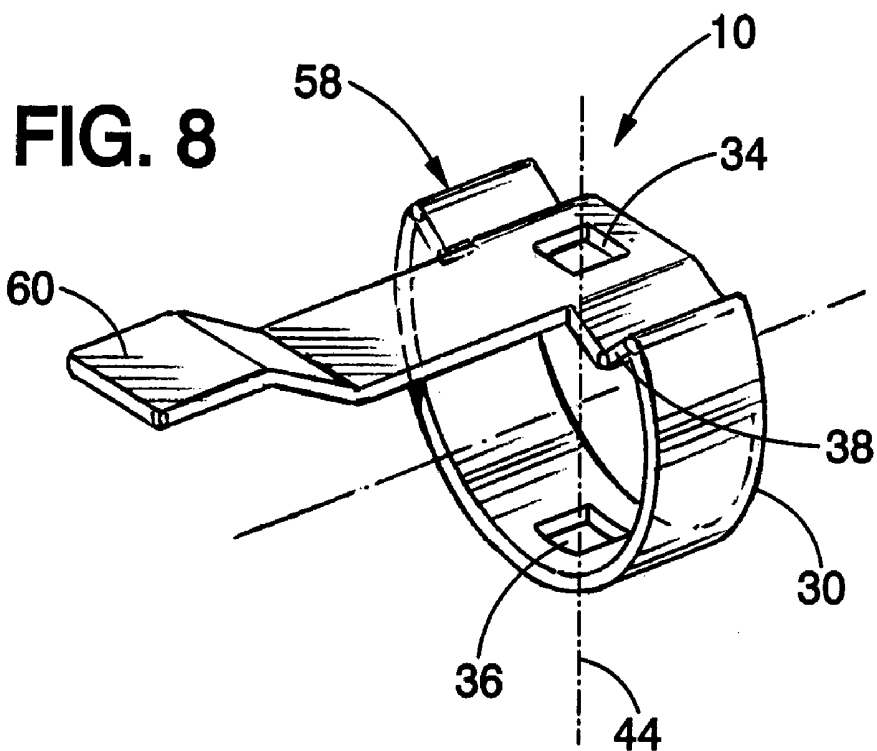

FIG. 9

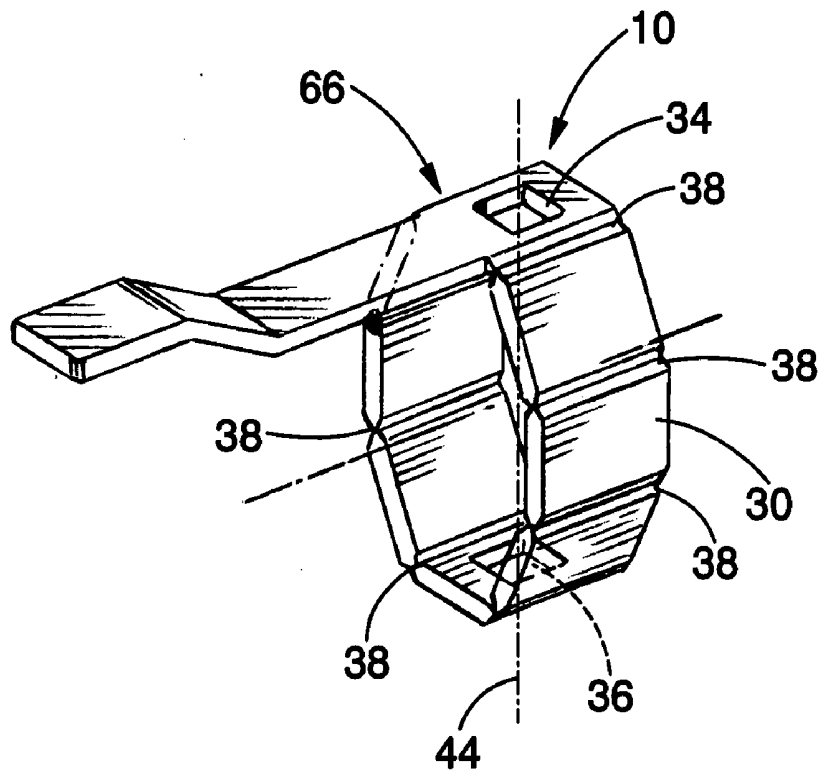
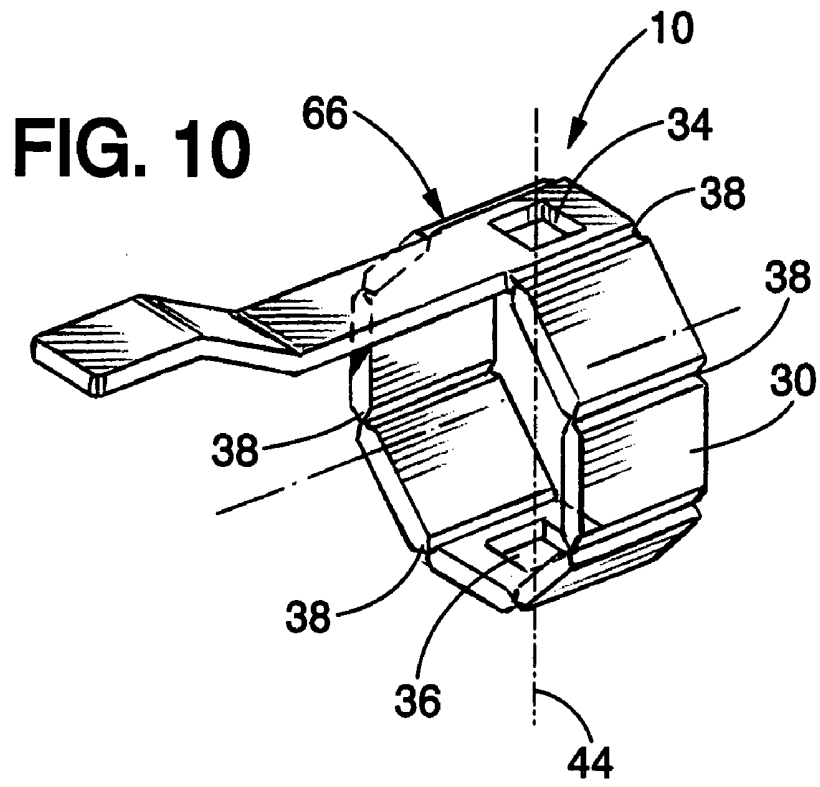

FIG. 11

FIG. 12

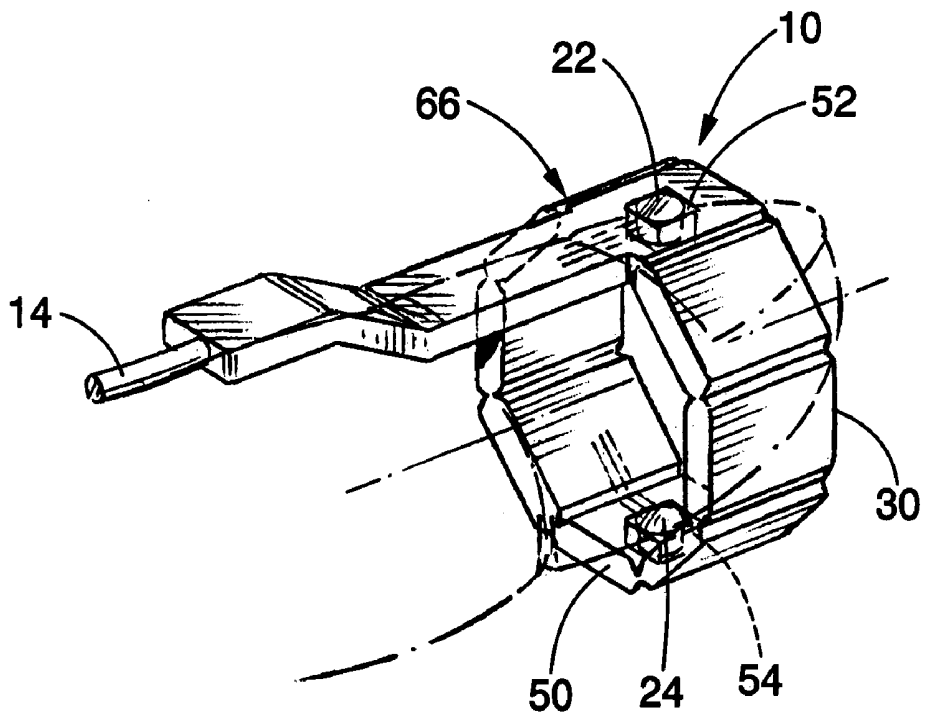
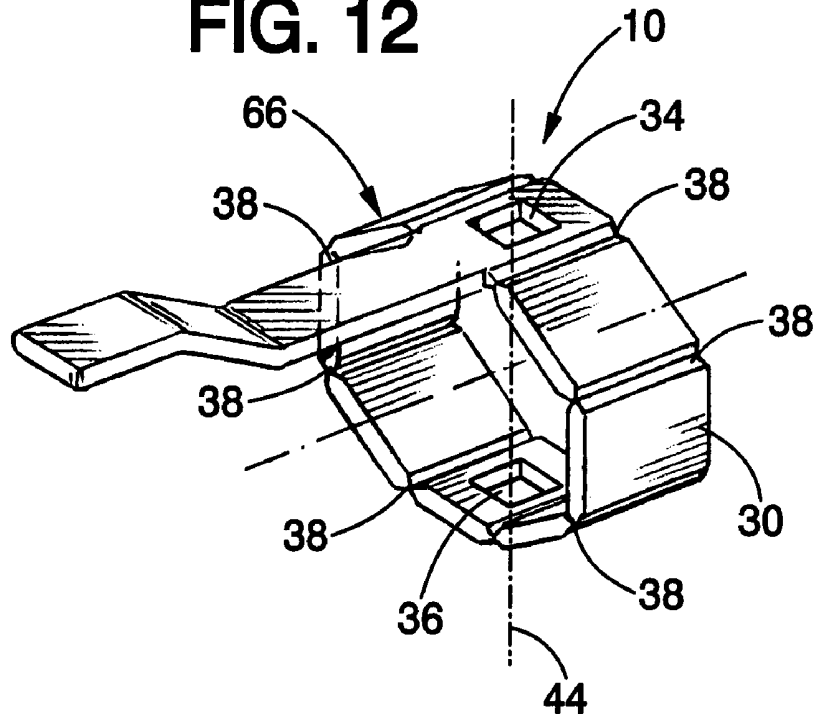

FIG. 13

**OPTICALLY ALIGNED PULSE OXIMETRY
SENSOR AND TECHNIQUE FOR USING THE
SAME**

BACKGROUND OF THE INVENTION

[0001] 1. Field of the Invention

[0002] The present invention relates generally to pulse oximetry and, more particularly, to sensors used for pulse oximetry.

[0003] 2. Description of the Related Art

[0004] This section is intended to introduce the reader to various aspects of art that may be related to various aspects of the present invention, which are described and/or claimed below. This discussion is believed to be helpful in providing the reader with background information to facilitate a better understanding of the various aspects of the present invention. Accordingly, it should be understood that these statements are to be read in this light, and not as admissions of prior art.

[0005] In the field of medicine, doctors often desire to monitor certain physiological characteristics of their patients. Accordingly, a wide variety of devices have been developed for monitoring physiological characteristics. Such devices provide doctors and other healthcare personnel with the information they need to provide the best possible healthcare for their patients. As a result, such monitoring devices have become an indispensable part of modern medicine.

[0006] One technique for monitoring certain physiological characteristics of a patient is commonly referred to as pulse oximetry, and the devices built based upon pulse oximetry techniques are commonly referred to as pulse oximeters. Pulse oximetry may be used to measure various blood flow characteristics, such as the blood-oxygen saturation of hemoglobin in arterial blood, the volume of individual blood pulsations supplying the tissue, and/or the rate of blood pulsations corresponding to each heartbeat of a patient.

[0007] Pulse oximeters typically utilize a non-invasive sensor that is placed on or against a patient's tissue that is well perfused with blood, such as a patient's finger, toe, or earlobe. The pulse oximeter sensor emits light and photoelectrically senses the absorption and/or scattering of the light after passage through the perfused tissue. The data collected by the sensor may then be used to calculate one or more of the above physiological characteristics based upon the absorption or scattering of the light. More specifically, the emitted light is typically selected to be of one or more wavelengths that are absorbed or scattered in an amount related to the presence of oxygenated versus de-oxygenated hemoglobin in the blood. The amount of light absorbed and/or scattered may then be used to estimate the amount of the oxygen in the tissue using various algorithms.

[0008] In many instances, it may be desirable to employ, for cost and/or convenience, a pulse oximeter sensor that is reusable. Such reusable sensors, however, should fit snugly enough that incidental patient motion will not dislodge or move the sensor yet not so tight that normal blood flow is disrupted, which may interfere with pulse oximetry measurements. Such a conforming fit may be difficult to achieve over a range of patient physiologies without adjustment or

excessive attention on the part of medical personnel. In addition, for transmission-type pulse oximetry sensors (in which an emitter and detector are provided on opposite sides of the finger or toe) it may be difficult to maintain the desired alignment of optical components while obtaining a conforming fit. For example, it may be desirable to maintain the emitter and detector along a common axis, however, such alignment may be difficult to achieve or maintain while adjusting the sensor and its constituent components to fit a patient physiology.

SUMMARY

[0009] Certain aspects commensurate in scope with the originally claimed invention are set forth below. It should be understood that these aspects are presented merely to provide the reader with a brief summary of certain forms of the invention might take and that these aspects are not intended to limit the scope of the invention. Indeed, the invention may encompass a variety of aspects that may not be set forth below.

[0010] There is provided a sensor assembly that includes: a frame comprising one or more pair of flexible elements disposed substantially symmetric relative to an optical axis; at least two optical components disposed on the frame along the optical axis; and a covering provided over at least part of the frame and the at least two optical components.

[0011] There is provided a sensor assembly that includes: a frame; an emitter and a detector housed on the frame along an optical axis, wherein the emitter and the detector are configured to move relative to one another while remaining aligned along the optical axis; and a covering provided over the frame, the emitter, and the detector.

[0012] There is provided a method of manufacturing a sensor that includes: situating an emitter and a detector on a frame, wherein the frame comprises one or more pair of flexible elements disposed substantially symmetric relative to an optical axis upon which the emitter and the detector are situated; and coating the frame with a coating material to form a sensor assembly.

[0013] There is provided a method for acquiring physiological data that includes: emitting two or more wavelengths of light from an emitter of a sensor assembly disposed on a patient; detecting transmitted or reflected light using a photodetector of the sensor assembly, wherein the emitter and the photodetector are maintained in optical alignment with one another along an optical axis by one or more pair of flexible elements of the sensor assembly, wherein the one or more pair of flexible elements are disposed symmetrical to the optical axis; and determining a physiological parameter based on the detected light.

[0014] There is provided a method of manufacturing a sensor body that includes: coating a frame with a coating material to form a sensor body, wherein the frame comprises one or more pair of flexible elements disposed substantially symmetric relative to an optical axis defined by an emitter housing and a detector housing of the frame.

[0015] There is provided a sensor body, that includes: a frame comprising one or more pair of flexible elements disposed substantially symmetric relative to an optical axis defined by an emitter housing and a detector housing of the frame; and a covering provided over the frame.

[0016] There is provided a sensor body, that includes: a frame comprising an emitter housing and a detector housing which define an optical axis, wherein the emitter housing and the detector housing are configured to move relative to one another while remaining aligned along the optical axis; and a covering provided over the frame to form a sensor assembly.

[0017] There is provided a frame of a sensor, that includes: at least two optical component housings defining an optical axis; and one or more pair of flexible elements disposed substantially symmetric relative to the optical axis.

[0018] There is provided a frame of a sensor, that includes: an emitter housing and a detector housing which define an optical axis, wherein the emitter housing and the detector housing are configured to move relative to one another while remaining aligned along optical axis.

[0019] There is provided a method for manufacturing a frame of a sensor, that includes: forming at least two optical component housings of a frame of a sensor such that the at least two optical component housings define an optical axis; and providing one or more pair of flexible elements on the frame disposed substantially symmetric relative to the optical axis.

BRIEF DESCRIPTION OF THE DRAWINGS

[0020] Advantages of the invention may become apparent upon reading the following detailed description and upon reference to the drawings in which:

[0021] FIG. 1 illustrates a physiological monitoring system coupled to a multi-parameter patient monitor and a patient sensor, in accordance with aspects of the present technique;

[0022] FIG. 2 illustrates a perspective view of one configuration of an internal frame for use in a patient sensor, in accordance with aspects of the present technique;

[0023] FIG. 3 illustrates the internal frame of FIG. 2 in an expanded configuration;

[0024] FIG. 4 illustrates the internal frame of FIG. 2 in a collapsed configuration;

[0025] FIG. 5 illustrates a perspective view of a covered patient sensor based upon the internal frame of FIG. 2;

[0026] FIG. 6 illustrates a perspective view of another configuration of an internal frame for use in a patient sensor, in accordance with aspects of the present technique;

[0027] FIG. 7 illustrates the internal frame of FIG. 6 in an expanded configuration;

[0028] FIG. 8 illustrates the internal frame of FIG. 6 in a collapsed configuration;

[0029] FIG. 9 illustrates a perspective view of a covered patient sensor based upon the internal frame of FIG. 6;

[0030] FIG. 10 illustrates a perspective view of a further configuration of an internal frame for use in a patient sensor, in accordance with aspects of the present technique;

[0031] FIG. 11 illustrates the internal frame of FIG. 10 in an expanded configuration;

[0032] FIG. 12 illustrates the internal frame of FIG. 10 in a collapsed configuration; and

[0033] FIG. 13 illustrates a perspective view of a covered patient sensor based upon the internal frame of FIG. 10.

DETAILED DESCRIPTION OF SPECIFIC EMBODIMENTS

[0034] One or more specific embodiments of the present invention will be described below. In an effort to provide a concise description of these embodiments, not all features of an actual implementation are described in the specification. It should be appreciated that in the development of any such actual implementation, as in any engineering or design project, numerous implementation-specific decisions must be made to achieve the developers' specific goals, such as compliance with system-related and business-related constraints, which may vary from one implementation to another. Moreover, it should be appreciated that such a development effort might be complex and time consuming, but would nevertheless be a routine undertaking of design, fabrication, and manufacture for those of ordinary skill having the benefit of this disclosure.

[0035] It is desirable to provide a comfortable and conformable reusable patient sensor that is easily cleaned and that maintains alignment between optical components. In accordance with some aspects of the present technique, a reusable patient sensor is provided that includes a flexible frame, such as a framework incorporating living hinges, pin hinges, bar links, bending beams, and so forth, which allows the patient sensor to conform to fingers or toes of varying sizes while maintaining alignment of the optical components.

[0036] Prior to discussing such exemplary sensors in detail, it should be appreciated that such sensors are typically designed for use with a patient monitoring system. For example, referring now to FIG. 1, a sensor 10 according to the present invention may be used in conjunction with a patient monitor 12. In the depicted embodiment, a cable 14 connects the sensor 10 to the patient monitor 12. As will be appreciated by those of ordinary skill in the art, the sensor 10 and/or the cable 14 may include or incorporate one or more integrated circuit devices or electrical devices, such as a memory, processor chip, or resistor that may facilitate or enhance communication between the sensor 10 and the patient monitor 12. Likewise the cable 14 may be an adaptor cable, with or without an integrated circuit or electrical device, for facilitating communication between the sensor 10 and various types of monitors, including older or newer versions of the patient monitor 12 or other physiological monitors. In other embodiments, the sensor 10 and the patient monitor 12 may communicate via wireless means, such as using radio, infrared, or optical signals. In such embodiments, a transmission device (not shown) may be connected to the sensor 10 to facilitate wireless transmission between the sensor 10 and the patient monitor 12. As will be appreciated by those of ordinary skill in the art, the cable 14 (or corresponding wireless transmissions) are typically used to transmit control or timing signals from the monitor 12 to the sensor 10 and/or to transmit acquired data from the sensor 10 to the monitor 12. In some embodiments, however, the cable 14 may be an optical fiber that allows optical signals to be conducted between the monitor 12 and the sensor 10.

[0037] In one embodiment, the patient monitor **12** may be a suitable pulse oximeter, such as those available from Nellcor Puritan Bennett Inc. In other embodiments, the patient monitor **12** may be a monitor suitable for measuring tissue water fractions, or other body fluid related metrics, using spectrophotometric or other techniques. Furthermore, the monitor **12** may be a multi-purpose monitor suitable for performing pulse oximetry and measurement of tissue water fraction, or other combinations of physiological and/or biochemical monitoring processes, using data acquired via the sensor **10**. Furthermore, to upgrade conventional monitoring functions provided by the monitor **12** to provide additional functions, the patient monitor **12** may be coupled to a multi-parameter patient monitor **16** via a cable **18** connected to a sensor input port and/or via a cable **20** connected to a digital communication port.

[0038] The sensor **10**, in the example depicted in FIG. 1, may be covered to provide a unitary or enclosed assembly. Such covering, however, is optional. The sensor **10**, includes an emitter **22** and a detector **24** which may be of any suitable type. For example, the emitter **22** may be one or more light emitting diodes adapted to transmit one or more wavelengths of light, such as in the red to infrared range, and the detector **24** may be a photodetector, such as a silicon photodiode package, selected to receive light in the range emitted from the emitter **22**. In the depicted embodiment, the sensor **10** is coupled to a cable **14** that is responsible for transmitting electrical and/or optical signals to and from the emitter **22** and detector **24** of the sensor **10**. The cable **14** may be permanently coupled to the sensor **10**, or it may be removably coupled to the sensor **10**—the latter alternative being more useful and cost efficient in situations where the sensor **10** is disposable.

[0039] The sensor **10** described above is generally configured for use as a “transmission type” sensor for use in spectrophotometric applications. As will be appreciated by those of ordinary skill in the art, however, such discussion is merely exemplary and is not intended to limit the scope of the present technique. Transmission type sensors include an emitter and detector that are typically placed on opposing sides of the sensor site. If the sensor site is a fingertip, for example, the sensor **10** is positioned over the patient’s fingertip such that the emitter and detector lie on either side of the patient’s nail bed. For example, the sensor **10** is positioned so that the emitter is located on the patient’s fingernail and the detector is located opposite the emitter on the patient’s finger pad. During operation, the emitter shines one or more wavelengths of light through the patient’s fingertip, or other tissue, and the light received by the detector is processed to determine various physiological characteristics of the patient.

[0040] For pulse oximetry applications using transmission type sensors the oxygen saturation of the patient’s arterial blood may be determined using two or more wavelengths of light, most commonly red and near infrared wavelengths. Similarly, in other applications a tissue water fraction (or other body fluid related metric) or a concentration of one or more biochemical components in an aqueous environment may be measured using two or more wavelengths of light, most commonly near infrared wavelengths between about 1,000 nm to about 2,500 nm. It should be understood that, as used herein, the term “light” may refer to one or more of infrared, visible, ultraviolet, or even X-ray electromagnetic

radiation, and may also include any wavelength within the infrared, visible, ultraviolet, or X-ray spectra.

[0041] Pulse oximetry and other spectrophotometric sensors are typically placed on a patient in a location conducive to measurement of the desired physiological parameters. For example, pulse oximetry sensors are typically placed on a patient in a location that is normally perfused with arterial blood to facilitate measurement of the desired blood characteristics, such as arterial oxygen saturation measurement (SaO₂). Common pulse oximetry sensor sites include a patient’s fingertips, toes, forehead, or earlobes. Regardless of the placement of the sensor **10**, the reliability of the pulse oximetry measurement is related to the accurate detection of transmitted light that has passed through the perfused tissue and has not been inappropriately supplemented by outside light sources or modulated by subdermal anatomic structures. Such inappropriate supplementation and/or modulation of the light transmitted by the sensor can cause variability in the resulting pulse oximetry measurements.

[0042] Referring now to FIGS. 2-13, the sensor **10** is discussed in greater detail. For example, in FIGS. 2-4, a first configuration **28** of an exemplary frame **30** for a sensor **10** is depicted. Such a frame **30** may provide an internal structure that defines the general shape of the sensor **10** when covered, such as by overmolding, to form the patient sensor **10**. In such an embodiment, the frame **30** may provide a general structure and range of motion for the patient sensor **10** while the covering may provide a surface area which contacts the patient and may protect the frame **30** and optical components of the patient sensor **10**. In view of the various structural and motion functions performed by the frame **30**, different structures or regions of the frame **30** may have similar or different rigidities or other mechanical properties.

[0043] The frame **30** may include various structural features such as a cable guide through which a cable, such as an electrical or optical cable, may pass to connect to the electrical or optical conductors attached to the emitter **22** and/or detector **24** upon assembly. Likewise, the frame **30** may include component housings, such as the emitter housing **34** and detector housing **36**. In addition, the frame **30** may include flexible components or elements **38**, such as living hinges, pin hinges, bar links, bending beams, and so forth, which facilitate the motion of the emitter housing **34** and/or the detector housing **36** relative to one another.

[0044] In certain embodiments, the frame **30** is constructed, in whole or in part, from polymeric materials, such as thermoplastics, capable of providing a suitable rigidity or semi-rigidity for the different portions of the frame **30**. Examples of such suitable materials include polyurethane, polypropylene, and nylon, though other polymeric materials may also be suitable. In other embodiments, the frame **30** is constructed, in whole or in part, from other suitably rigid or semi-rigid materials that provide the desired support and flexibility, such as stainless steel, aluminum, magnesium, graphite, fiberglass, or other metals, alloys, or compositions that are sufficiently ductile and/or strong. For example, metals, alloys, or compositions that are suitable for diecasting, sintering, lost wax casting, stamping and forming, and other metal or composition fabrication processes may be used to construct the frame **30**.

[0045] In addition, the frame **30** may be constructed as an integral structure or as a composite structure. For example,

in one embodiment, the frame 30 may be constructed as a single piece from a single material or from different materials. Alternatively, the frame 30 may be constructed or assembled as a composite structure from two or more parts that are separately formed. In such embodiments, the different parts may be formed from the same or different materials. For example, in implementations where different parts are formed from different materials, each part may be constructed from a material having suitable mechanical and/or chemical properties for that part. The different parts may then be joined or fitted together to form the frame 30, such as by a snap fitting process, ultrasonic welding, heat staking or by application of an adhesive or mechanical fastener.

[0046] For example, the flexible elements 38, such as living hinges, pin hinges, bar links, bending beams, and so forth, may be constructed from the same materials and/or from different materials than the remainder of the frame 30. Furthermore, the flexible elements 38 may be formed integrally with the remainder of the frame 30. For example, in one embodiment, the frame 30 may be molded from polymeric materials as one piece, with the flexible elements 38 formed as living hinges molded from the polymeric material. Alternatively, some or all of the flexible elements 38 may be molded or formed as separate pieces that are attached to the remainder of the frame structure. In such embodiments, the flexible elements 38 may be formed from the same or different materials and the remainder of the frame 30 and may serve to hold different portions of the frame structure together. For example, in an embodiment in which the flexible elements 38 are pin hinges, the frame sides 42 may be formed from polymeric materials and may include annular structures along their edges that are complementary to the annular structures of an adjacent frame side 42. In such an embodiment, a pin, such as a metal pin, may be fitted through the annular structures of two adjacent frame sides 42, thereby forming an attachment and a hinge upon which the attached frame sides 42 may be moved. As will be appreciated by those of ordinary skill in the art, other suitable hinge and/or attachment techniques may also be applicable to construct the frame 30.

[0047] Furthermore, the frame 30 may be molded, formed, or constructed in a different configuration than the final sensor configuration. For example, the frame 30 for use in the sensor 10 may be initially formed, from one or more pieces, in a generally open, or flat, configuration compared to the relatively closed configuration of the frame 30 when folded to form the sensor 10. In such embodiments, the frame 30 may be formed generally open or planar and then folded or bent, such as at the flexible regions 38, into the closed configuration associated with the sensor 10. A covering may be applied, such as by overmolding, prior to or subsequent to folding or bending the frame 30 from the open configuration to the closed configuration. In such an embodiment, the frame 30 may be secured together as described above, such as via a snap fitting process or via other techniques suitable for attaching the respective portions of the frame 30 including ultrasonic welding, heat staking or by application of an adhesive or mechanical fastener.

[0048] In the example depicted in FIGS. 2-4, a first configuration 28 of the frame 30 is provided. In the first configuration 28, the flexible regions 38 are provided in

pairs that are symmetric about a vertical plane that coincides with the optical axis 44. The paired, symmetric flexible regions 38 allow lineal expansion and/or contraction along the optical axis 44, thereby maintaining optical alignment of the emitter 22 and detector 24 as the frame 30 expands or collapses to conformably fit a patient's digit. In addition, the flexible regions 38 may allow lateral expansion (i.e., transverse to the optical axis) of the frame 30 to provide a laterally conforming fit to differently sized fingers and toes.

[0049] For example, referring now to FIG. 3, the first configuration 28 of FIG. 2 is depicted as expanded along the optical axis 44 between the emitter 22 and detector 24, such as to accommodate a large finger or toe needing greater vertical space. The paired, symmetric flexible regions 38 constrain the range of motion of the emitter 22 and detector 24 to linear motion along the optical axis 44, thereby maintaining the emitter 22 and detector 24 in alignment despite their motion relative to one another. Similarly, referring now to FIG. 4, the first configuration 28 is depicted as collapsed along the optical axis 44, such as to accommodate a smaller finger or toe, while maintaining alignment of the emitter 22 and detector 24 along the optical axis 44.

[0050] As noted above, in certain embodiments of the present technique, the frame 30 (such as the first configuration 28 of the frame 30) may be covered to form a unitary or integral sensor assembly or sensor body, as depicted in FIG. 5. Such covered embodiments may result in a sensor assembly in which the internal frame 30 is completely or substantially covered by a covering material 50. In embodiments in which the internal frame 30 is formed or molded as a relatively open or flat structure, the covering process may be performed prior to or subsequent to bending the internal frame 30 into the closed configuration.

[0051] For example, the sensor 10 may be formed by an injection molding process. In one example of such a process the internal frame 30 may be positioned within a die or mold of the desired shape for the sensor 10. A molten or otherwise unset overmold material may then be injected into the die or mold. For example, in one implementation, a molten thermoplastic elastomer at between about 400° F. to about 450° F. is injected into the mold. The coating material may then be set, such as by cooling for one or more minutes or by chemical treatment, to form the sensor body about the internal frame 30. In certain embodiments, other sensor components, such as the emitter 22 and/or detector 24, may be attached or inserted into their respective housings or positions on the overmolded sensor body.

[0052] Alternatively, the optical components (such as emitter 22 and detector 24) and/or conductive structures (such as wires or flex circuits) may be placed on the internal frame 30 prior to overmolding. The internal frame 30 and associated components may then be positioned within a die or mold and overmolded, as previously described. To protect the emitter 22, detector 24, and/or other electrical components, conventional techniques for protecting such components from excessive temperatures may be employed. For example, the emitter 22 and/or the detector 24 may include an associated clear window, such as a plastic or crystal window, in contact with the mold to prevent coating 50 from being applied over the window. In one embodiment, the material in contact with such windows may be composed of a material, such as beryllium copper, which prevents the heat

of the injection molding process from being conveyed through the window to the optical components. For example, in one embodiment, a beryllium copper material initially at about 40° F. is contacted with the windows associated with the emitter 22 and/or detector 24 to prevent coating of the windows and heat transfer to the respective optical components.

[0053] As will be appreciated by those of ordinary skill in the art, the injection molding process described herein is merely one technique by which the frame 30 may be covered to form a sensor body, with or without associated sensing components. Other techniques which may be employed include, but are not limited to, dipping the frame 30 into a molten or otherwise unset coating material to coat the frame 30 or spraying the frame 30 with a molten or otherwise unset coating material to coat the frame 30. In such implementations, the coating material may be subsequently set, such as by cooling or chemical means, to form the coating. Such alternative techniques, to the extent that they may involve high temperatures, may include thermally protecting whatever optical components are present, such as by using beryllium copper or other suitable materials to prevent heat transfer through the windows associated with the optical components, as discussed above.

[0054] The frame 30 may be covered by other techniques as well. For example, the covering material 50 may be a sheet, a sleeve, or a film material which is applied to the frame. Such a covering material 50 may be bonded, such as with an adhesive material, or mechanically fastened to the frame 30. For instance, a suitable film material may be an extruded or laminated film that is adhesively or mechanically bonded to the frame 30. Likewise, a suitable sheet material may be a single or multi-layer sheet material that is adhesively or mechanically bonded to the frame 30. Other exemplary covering material 50 include cast, foamed, or extruded materials suitable for attachment to the frame 30.

[0055] By such techniques, the frame 30, as well as the optical components and associated circuitry where desired, may be encased in a covering material 50 to form an integral or unitary assembly with no exposed or external moving parts of the internal frame 30. For example, as depicted in FIG. 5, the sensor 10 includes features of the underlying internal frame 30 that are now completely or partially covered, such as the overmolded emitter housing 52 and detector housing 54.

[0056] In one implementation, the covering material 50 is a thermoplastic elastomer or other conformable coating or material. In such embodiments, the thermoplastic elastomer may include compositions such as thermoplastic polyolefins, thermoplastic vulcanizate alloys, silicone, thermoplastic polyurethane, and so forth. As will be appreciated by those of ordinary skill in the art, the overmolding composition may vary, depending on the varying degrees of conformability, durability, wettability, or other physical and/or chemical traits that are desired.

[0057] Furthermore, the covering material 50 may be selected based upon the desirability of a chemical bond between the internal frame 30 and the covering material 50. Such a chemical bond may be desirable for durability of the resulting sensor 10. For example, to prevent separation of the covering material 50 from the internal frame 30, a covering material 50 may be selected such that the covering

material 50 bonds with some or all of the internal frame 30. In such embodiments, the covering material 50 and the portions of the internal frame 30 to which the covering material 50 is bonded are not separable, i.e., they form one continuous and generally inseparable structure.

[0058] Furthermore, in embodiments in which the covering material 50 employed is liquid or fluid tight, such a sensor 10 may be easily maintained, cleaned, and/or disinfected by immersing the sensor into a disinfectant or cleaning solution or by rinsing the sensor 10 off, such as under running water. In particular, such a covered sensor assembly may be generally or substantially free of crevices, gaps, junctions or other surface irregularities typically associated with a multi-part construction which may normally allow the accumulation of biological detritus or residue. Such an absence of crevices and other irregularities may further facilitate the cleaning and care of the sensor 10.

[0059] In the depicted example, flexible regions 38 of the frame 30 incorporated into the sensor 10 (in either coated or uncoated embodiments) provide vertical and/or lateral accommodation of a finger or other patient digit, and thereby providing a conforming fit. Furthermore, in the depicted embodiment, the lateral sides of the frame 30 (or the covering material 50 disposed over such lateral sides) facilitate the exclusion of environmental or ambient light from the interior of the sensor 10. The lateral sides of the sensor 10, therefore, help prevent or reduce the detection of light from the outside environment, which may be inappropriately detected by the sensor 10 as correlating to the SaO₂. Thus, the pulse oximetry sensor may detect differences in signal modulations unrelated to the underlying SaO₂ level. In turn, this may impact the detected red-to-infrared modulation ratio and, consequently, the measured blood oxygen saturation (SpO₂) value. The conformability of the fit of sensor 10 and the presence of the lateral sides on the sensor 10, therefore, may help prevent or reduce such errors.

[0060] While the frame 30 in the first configuration 28 may be used to form a covered or uncovered sensor 10, other frame configurations may also be used in accordance with the present technique. For example, referring now to FIGS. 6-8, a second frame configuration 58 is depicted. The exemplary second frame configuration 58 includes components noted above with regard to the first configuration 28, such as a symmetric pair of flexible regions 38, an emitter housing 34, and a detector housing 36, as well as a cable guide 60.

[0061] In the embodiment depicted in FIGS. 6-8, the second configuration 58 of the frame 30 is provided as a semi-rigid, generally annular structure upon which the emitter housing 34 and detector housing 36 are disposed opposite one another. Between the emitter housing 34 and detector housing 36, a symmetric pair of flexible regions 38 (as discussed with regard to FIGS. 2-4) is disposed. The flexible regions 38 function as discussed above, allowing the emitter housing 34 (and associated emitter 22) and detector housing 36 (and associated detector 24) to move relative to one another along the optical axis 44. In this manner, alignment of optical components, such as an emitter 22 and detector 24 may be maintained while obtaining a conforming fit to a patient's digit. While the second configuration of FIG. 6 is depicted with one pair of symmetrical flexible regions 38, one of ordinary skill in the art will appreciate that additional

flexible regions 38 may be provided on the second configuration 58 of the frame 30 to maintain optical alignment of the emitter 22 and detector 24.

[0062] Referring now to FIG. 7, the second configuration 58 of the frame 30 is depicted as expanded along the optical axis 44 between the emitter 22 and detector 24, such as to accommodate a large finger or toe needing greater vertical space. The paired, symmetric flexible regions 38 constrain the range of motion of the emitter 22 and detector 24 to linear motion along the optical axis 44, thereby maintaining the emitter 22 and detector 24 in alignment despite their motion relative to one another. Similarly, in FIG. 8, the second configuration 58 is depicted as collapsed along the optical axis 44, such as to accommodate a smaller finger or toe, while maintaining alignment of the emitter 22 and detector 24 along the optical axis 44.

[0063] The second configuration 58 of the frame 30 is depicted as covered in FIG. 9. The techniques and materials that may be used to cover the second configuration 58 of the frame 30 are the same or similar to those discussed above with regard to the covered first configuration 28 of frame 30 discussed in relation to FIG. 5. Likewise the covered structures and benefits are the same or similar to those discussed above with regard to the covered configuration of FIG. 5. In this manner, a unitary sensor or sensor body may be constructed about the second configuration 58 of the frame 30 that provides a conforming fit while maintaining the optical alignment of the optical components.

[0064] Other frame configurations incorporating aspects of the present technique are also possible. For example, referring now to FIGS. 10-12, a third frame configuration 66 is depicted. The exemplary third frame configuration 66 includes components noted above with regard to the first and second configurations 28 and 58, such as symmetric pairs of flexible regions 38, an emitter housing 34, and a detector housing 36.

[0065] In the embodiment depicted in FIGS. 10-12, the third configuration 66 of the frame 30 is provided as a hinged, loop structure upon which the emitter housing 34 and detector housing 36 are disposed opposite one another. Between the emitter housing 34 and detector housing 36, four symmetric pairs of flexible regions 38 is disposed. The flexible regions 38 function as discussed above, allowing the emitter housing 34 (and associated emitter 22) and detector housing 36 (and associated detector 24) to move relative to one another along the optical axis 44. In this manner, alignment of optical components, such as an emitter 22 and detector 24 may be maintained while obtaining a conforming fit to a patient's digit. While the third configuration of FIG. 10 is depicted with four pairs of symmetrical flexible regions 38, one of ordinary skill in the art will appreciate that less than or more than four flexible regions 38 may be provided on the third configuration 66 of the frame 30 to maintain optical alignment of the emitter 22 and detector 24.

[0066] Referring now to FIG. 11, the third configuration 66 of the frame 30 is depicted as expanded along the optical axis 44 between the emitter 22 and detector 24, such as to accommodate a large finger or toe needing greater vertical space. The paired, symmetric flexible regions 38 constrain the range of motion of the emitter 22 and detector 24 to linear motion along the optical axis 44, thereby maintaining the emitter 22 and detector 24 in alignment despite their motion relative to one another. Similarly, in FIG. 12, the third configuration 66 is depicted as collapsed along the optical axis 44, such as to accommodate a smaller finger or

toe, while maintaining alignment of the emitter 22 and detector 24 along the optical axis 44.

[0067] The third configuration 66 of the frame 30 is depicted as covered in FIG. 13. The techniques and materials that may be used to cover the third configuration 66 of the frame 30 are similar to those discussed above with regard to the covered first configuration 28 of frame 30 discussed in relation to FIG. 5. Likewise the covered structures and benefits are the same or similar to those discussed above with regard to the covered configuration of FIG. 5. In this manner, a unitary sensor or sensor body may be constructed about the third configuration 66 of the frame 30 that provides a conforming fit while maintaining the optical alignment of the optical components.

[0068] While the exemplary medical sensors 10 discussed herein are provided as examples, other such devices are also contemplated and fall within the scope of the present disclosure. For example, other medical sensors and/or contacts applied externally to a patient may be advantageously applied using an covered sensor body as discussed herein. Examples of such sensors or contacts may include glucose monitors or other sensors or contacts that are generally held adjacent to the skin of a patient such that a conformable and comfortable fit is desired. Similarly, and as noted above, devices for measuring tissue water fraction or other body fluid related metrics may utilize a sensor as described herein. Likewise, other spectrophotometric applications where a probe is attached to a patient may utilize a sensor as described herein.

[0069] Furthermore, though the preceding discussion notes the possibility of covering the frame 30 with an overmold material to construct the sensor 10 or the sensor body, one of ordinary skill in the art will appreciate that the frame 30 may also be used without such a covering. For example, the frame 30 may itself form a sensor body, with optical components such as the emitter 22 and/or detector 24 being added to the frame 30 to form the sensor 10. In such an embodiment, an adhesive strip or bandage may help secure the sensor 10 to the patient.

[0070] While the invention may be susceptible to various modifications and alternative forms, specific embodiments have been shown by way of example in the drawings and have been described in detail herein. However, it should be understood that the invention is not intended to be limited to the particular forms disclosed. Rather, the invention is to cover all modifications, equivalents, and alternatives falling within the spirit and scope of the invention as defined by the following appended claims. Indeed, the present techniques may not only be applied to transmission type sensors for use in pulse oximetry, but also to retroreflective and other sensor designs as well. Likewise, the present techniques are not limited to use on fingers and toes but may also be applied to placement on other body parts such as in embodiments configured for use on the ears or nose.

What is claimed is:

1. A sensor assembly, comprising:
 - a frame comprising one or more pair of flexible elements disposed substantially symmetric relative to an optical axis;
 - at least two optical components disposed on the frame along the optical axis; and
 - a covering provided over at least part of the frame and the at least two optical components.

2. The sensor assembly of claim 1, wherein the frame comprises two or more parts joined to form the frame.

3. The sensor assembly of claim 1, wherein the covering comprises a thermoplastic elastomer.

4. The sensor assembly of claim 3, wherein the thermoplastic elastomer comprises at least one of a thermoplastic polyolefin, a thermoplastic vulcanizate alloy, thermoplastic polyurethane, silicone, or a combination thereof.

5. The sensor assembly of claim 1, wherein the covering comprises a flexible sheet, a sleeve or a film material.

6. The sensor assembly of claim 1, wherein the covering is bonded to the frame.

7. The sensor assembly of claim 1, wherein the covering is mechanically fastened to the frame.

8. The sensor assembly of claim 1, wherein the covering comprises a cast, foamed, or extruded material.

9. The sensor assembly of claim 1, wherein no moving parts of the frame remain exposed from the covering.

10. The sensor assembly of claim 1, comprising at least one integrated circuit device.

11. The sensor assembly of claim 1, wherein the one or more pair of flexible elements comprise one or more pair of living hinges, pin hinges, bar links, or bending beams.

12. A sensor assembly, comprising:

a frame;

an emitter and a detector housed on the frame along an optical axis, wherein the emitter and the detector are configured to move relative to one another while remaining aligned along the optical axis; and

a covering provided over the frame, the emitter, and the detector.

13. A method of manufacturing a sensor, comprising:

situating an emitter and a detector on a frame, wherein the frame comprises one or more pair of flexible elements disposed substantially symmetric relative to an optical axis upon which the emitter and the detector are situated; and

coating the frame with a coating material to form a sensor assembly.

14. A method for acquiring physiological data, comprising:

emitting two or more wavelengths of light from an emitter of a sensor assembly disposed on a patient;

detecting transmitted or reflected light using a photodetector of the sensor assembly, wherein the emitter and the photodetector are maintained in optical alignment with one another along an optical axis by one or more pair of flexible elements of the sensor assembly,

wherein the one or more pair of flexible elements are disposed symmetrical to the optical axis; and

determining a physiological parameter based on the detected light.

15. A method of manufacturing a sensor body, comprising:

coating a frame with a coating material to form a sensor body, wherein the frame comprises one or more pair of flexible elements disposed substantially symmetric relative to an optical axis defined by an emitter housing and a detector housing of the frame.

16. A sensor body, comprising:

a frame comprising one or more pair of flexible elements disposed substantially symmetric relative to an optical axis defined by an emitter housing and a detector housing of the frame; and

a covering provided over the frame.

17. A sensor body, comprising:

a frame comprising an emitter housing and a detector housing which define an optical axis, wherein the emitter housing and the detector housing are configured to move relative to one another while remaining aligned along the optical axis; and

a covering provided over the frame to form a sensor assembly.

18. A frame of a sensor, comprising:

at least two optical component housings defining an optical axis; and

one or more pair of flexible elements disposed substantially symmetric relative to the optical axis.

19. A frame of a sensor, comprising:

an emitter housing and a detector housing which define an optical axis, wherein the emitter housing and the detector housing are configured to move relative to one another while remaining aligned along optical axis.

20. A method for manufacturing a frame of a sensor, comprising:

forming at least two optical component housings of a frame of a sensor such that the at least two optical component housings define an optical axis; and

providing one or more pair of flexible elements on the frame disposed substantially symmetric relative to the optical axis.

* * * * *

专利名称(译)	光学对准的脉搏血氧饱和度传感器及其使用技术		
公开(公告)号	US20070078309A1	公开(公告)日	2007-04-05
申请号	US11/241031	申请日	2005-09-30
[标]申请(专利权)人(译)	MATLOCK GEORGE 大号		
申请(专利权)人(译)	MATLOCK GEORGE 大号		
当前申请(专利权)人(译)	COVIDIEN LP		
[标]发明人	MATLOCK GEORGE L		
发明人	MATLOCK, GEORGE L.		
IPC分类号	A61B5/00		
CPC分类号	A61B5/14552 A61B5/6826 A61B5/6838 A61B2562/12		
其他公开文献	US7486979		
外部链接	Espacenet USPTO		

摘要(译)

提供了一种生理传感器，其包括设置在框架上的发射器和检测器，使得发射器和检测器限定光轴。框架包括一对或多对柔性元件，这对柔性元件相对于光轴大致对称地设置。在一个实施例中，发射器和检测器在沿光轴相对于彼此移动时保持对准。

