



US 20060074479A1

(19) **United States**

(12) **Patent Application Publication**
Bailey et al.

(10) **Pub. No.: US 2006/0074479 A1**

(43) **Pub. Date: Apr. 6, 2006**

(54) **IN VIVO SENSOR AND METHOD OF MAKING SAME**

(52) **U.S. Cl.** 623/1.13; 623/1.15; 623/912

(76) Inventors: **Steven R. Bailey**, San Antonio, TX (US); **Christopher T. Boyle**, San Antonio, TX (US); **Denes Marton**, San Antonio, TX (US); **Christopher E. Banas**, San Antonio, TX (US)

(57) **ABSTRACT**

Implantable in vivo sensors used to monitor physical, chemical or electrical parameters within a body. The in vivo sensors are integral with an implantable medical device and are responsive to externally or internally applied energy. Upon application of energy, the sensors undergo a phase change in at least part of the material of the device which is then detected external to the body by conventional techniques such as radiography, ultrasound imaging, magnetic resonance imaging, radio frequency imaging or the like. The in vivo sensors of the present invention may be employed to provide volumetric measurements, flow rate measurements, pressure measurements, electrical measurements, biochemical measurements, temperature, measurements, or measure the degree and type of deposits within the lumen of an endoluminal implant, such as a stent or other type of endoluminal conduit. The in vivo sensors may also be used therapeutically to modulate mechanical and/or physical properties of the endoluminal implant in response to the sensed or monitored parameter.

Correspondence Address:
ROSENBAUM & ASSOCIATES, P.C.
650 DUNDEE ROAD
SUITE 380
NORTHBROOK, IL 60062-2757 (US)

(21) Appl. No.: **09/783,633**

(22) Filed: **Feb. 14, 2001**

Publication Classification

(51) **Int. Cl.**
A61F 2/06 (2006.01)

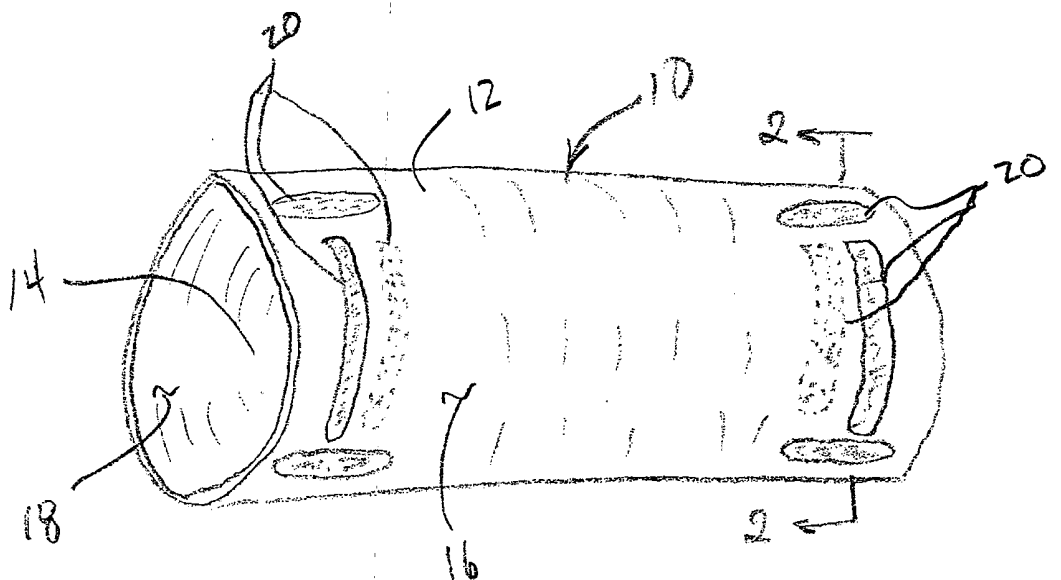

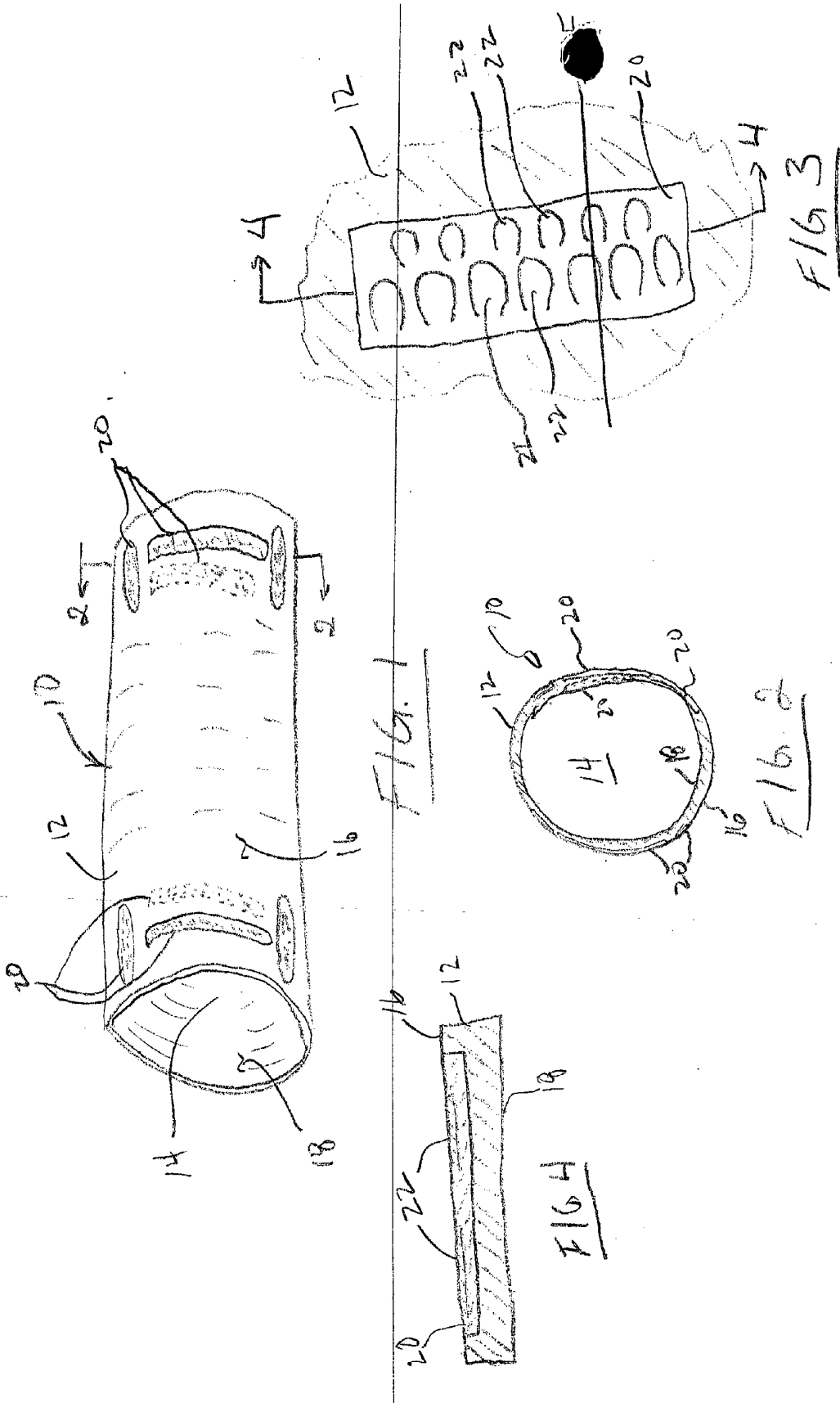

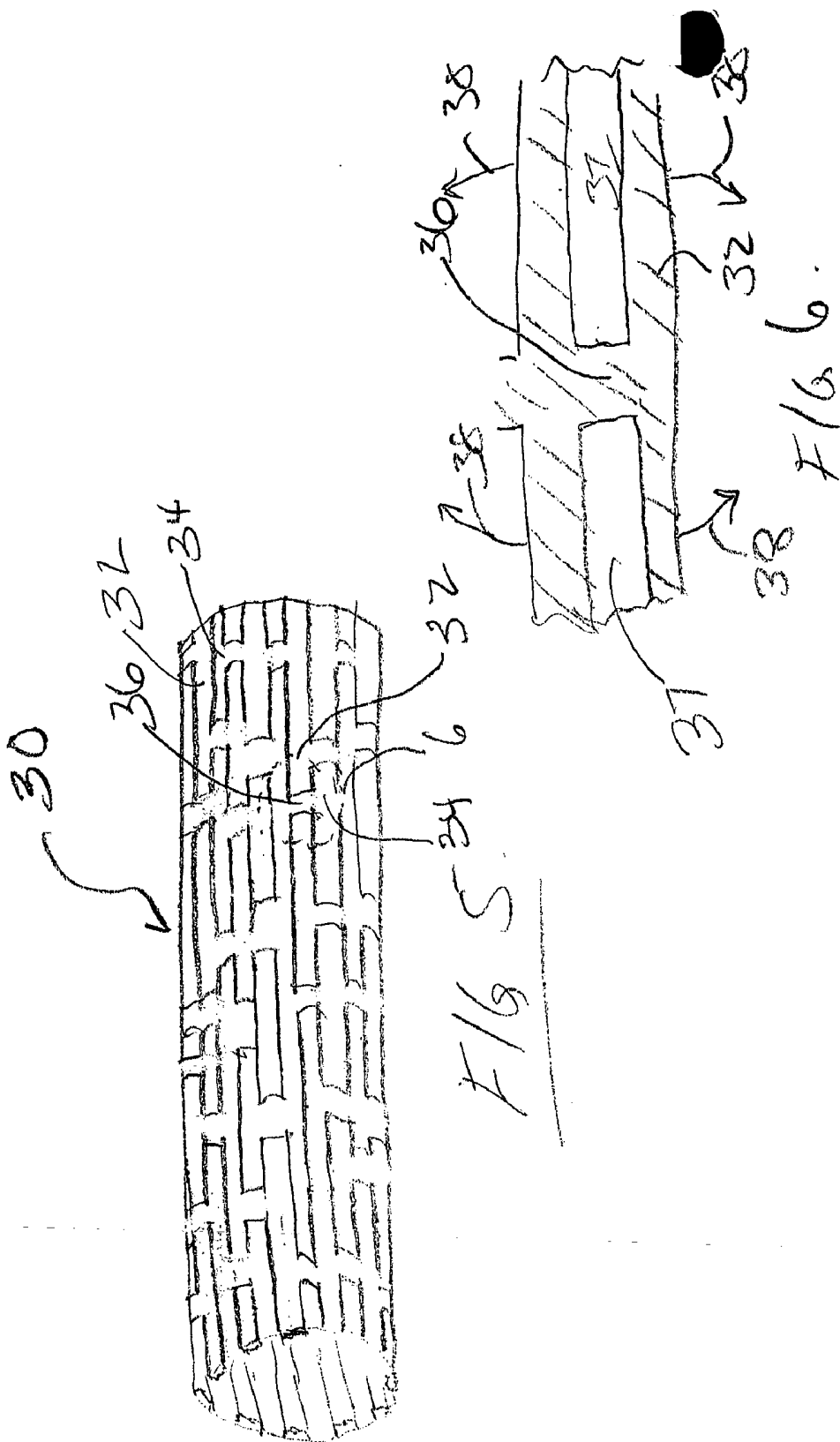

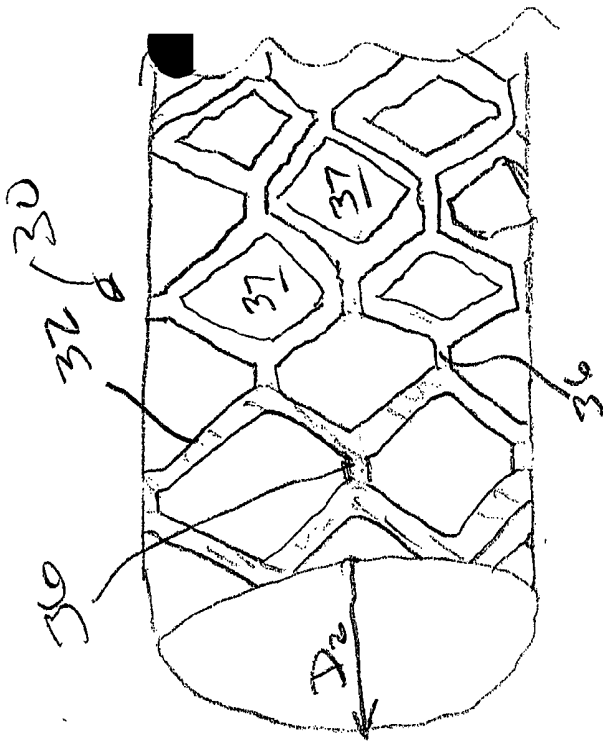

FIG 7B

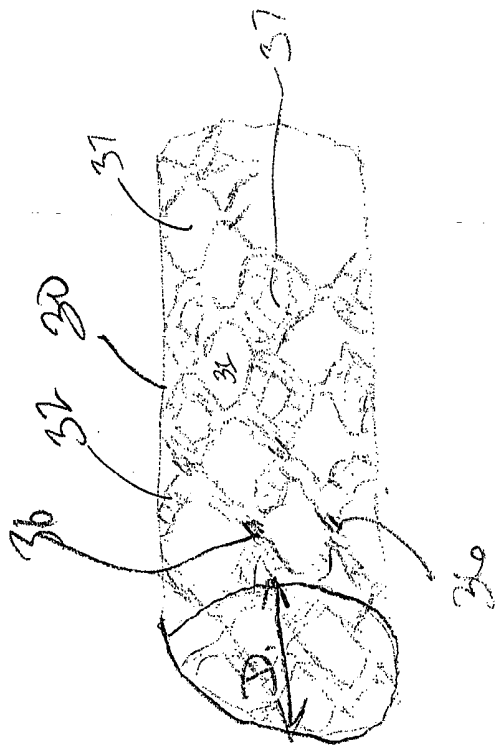
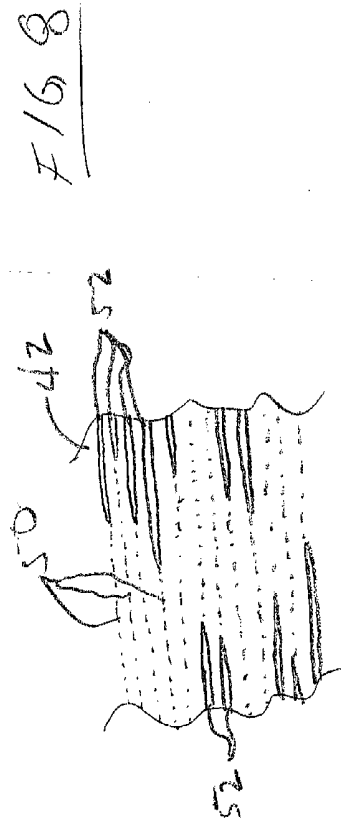
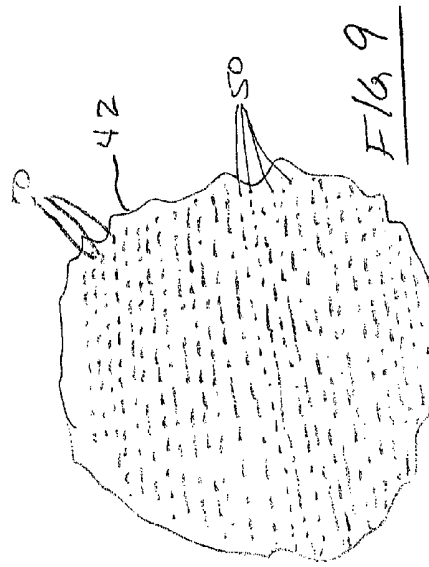
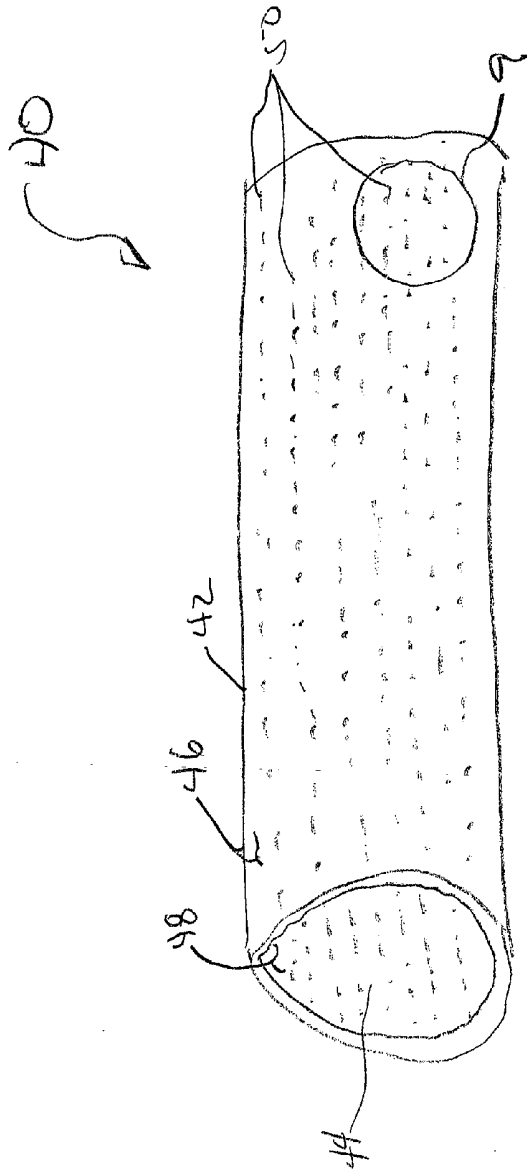

FIG 7A



IN VIVO SENSOR AND METHOD OF MAKING SAME

BACKGROUND OF THE INVENTION

[0001] The present invention relates generally to the field of implantable medical devices, and more particularly pertains to sensors that may be implanted into a body to elicit at least one of a mechanical, chemical or electrical response to an in vivo physiological condition or state with the body. The present invention provides a vacuum deposited film which may be either a monolithic monolayer of material or a multilayered film having at least portions of the film capable of sensing at least one of changes in temperature, pressure, or the presence or absence of chemical or biochemical species in the body by mechanical, electrical, chemical, electrochemical or electromechanical means.

[0002] Specifically, the present invention relates to the manufacture and use of implantable sensors to monitor physical, chemical or electrical parameters of a fluid flow through a body passageway. For example, the sensors of the present invention may be employed to provide volumetric measurements, flow rate measurements, pressure measurements, electrical measurements, biochemical measurements, temperature measurements, or measure the degree and type of deposits within the lumen of an endoluminal implant, such as a stent or other type of endoluminal conduit. The present invention also provides a means to modulate mechanical and/or physical properties of the endoluminal implant in response to the sensed or monitored parameter. For example, where the monitored blood flow volume through an endoluminal device is determined to be below physiological norms and/or the blood pressure is determined to be above physiological norms, the stent may be actuated to increase its diameter, such as by superelastic properties of the stent materials.

[0003] Post-implantation evaluation of the patency of an endoluminal device presently requires clinical examination by angiography or ultrasound. The results of these tests provide a qualitative evaluation of device patency. It is, therefore, desirable to provide a means for quantitatively measuring the post-implantation patency of an endoluminal device on either a periodic or continuous basis. Quantitative in vivo measurements of volumetric flow rate, flow velocity, biochemical constitution, fluid pressure or similar physical or biochemical property of the body fluid through an endoluminal device would provide more accurate diagnostic information to the medical practitioner.

[0004] As used herein, the term "endoluminal device" is intended to include stents, grafts and stent-grafts which are implanted within an anatomical passageway or are implanted with a body to create a non-anatomical passageway between anatomically separated regions within the body. Endoluminal devices in accordance with the present invention may include endovascular devices, prostatic devices, urethral devices, cervical devices, esophageal devices, intestinal devices, biliary devices, intra-cardiac devices, valves, hepatic devices, renal devices or devices with similar application within the body.

[0005] The term "sensor," as used in this application, is intended to include, without limitation, biosensors, chemical sensors, electrical sensors and mechanical sensors. While the term "biosensor" has been used to variously describe a

number of different devices which are used to monitor living systems or incorporating biological elements, the International Union for Pure and Applied Chemistry (IUPAC) has recommended that the term "biosensor" be used to describe "a device that uses specific biochemical reactions mediated by isolated enzymes, immunosystems, tissues, organelles or whole cells to detect chemical compounds usually by electrical, thermal or optical signals" 1992, 64, 148 IUPAC Compendium of Chemical Terminology 2nd Edition (1997). The term "chemical sensor" is defined by the IUPAC as a device that transforms chemical information, ranging from concentration of a specific sample component to total composition analysis, into an analytically useful signal. Conventional biosensors are a type of chemical sensor that consists of three basic elements: a receptor (biocomponent), transducer (physical component) and a separator (membrane or coating of some type). The receptor of a chemical sensor usually consists of a doped metal oxide or organic polymer capable of specifically interacting with the analyte or interacting to a greater or lesser extent when compared to other receptors. In the case of a biosensor the receptor or biocomponent converts the biochemical process or binding event into a measurable component. Biocomponents include biological species such as: enzymes, antigens, antibodies, receptors, tissues, whole cells, cell organelles, bacteria and nucleic acids. The transducer or physical component converts the component into a measurable signal, usually an electrical or optical signal. Physical components include: electrochemical devices, optical devices, acoustical devices, and calorimetric devices as examples. The interface or membrane separates the transducer from the chemical or biocomponent and links this component with the transducer. They are in intimate contact. The interface separator usually screens out unwanted materials, prevents fouling and protects the transducer. Types of interfaces include: polymer membranes, electropolymerized coatings and self-assembling monomers.

[0006] Sensors should have high selectivity and sensitivity, have rapid recovery times with no hysteresis, long lifetimes if not single use, low drift, automated calibration, self-diagnostic, low cost, no reagent additions required and no sample preparation. It is obvious that presently available chemical sensors and biosensors do not meet these criteria (World Biosensor Market, Frost and Sullivan, Report 5326-32, 1997). National Institute of Standards and Technology, *Nano-and MEMS Technologies for Chemical Biosensors*, (www.atp.nist.gov/atp/focus/98wp-nan.htm).

[0007] In the clinical diagnostic market, various sensor designs are known including electrochemical sensors (potentiometric ISEs; amperometric; conductometric; miniaturized ISEs; field effect transistors; interdigitated transistors); optical sensors using fiber-optic or surface plasmon resonance technologies; acoustic sensors such as piezo-crystal and surface acoustic wave sensors; and thermal sensors which employ thermistors. Thus, it is known to employ microfabrication techniques to make chemical sensors. Currently, the most commercially successful microfabricated sensor in the clinical diagnostic market is the MEDISENSE glucose meter that uses an electrochemical transduction of an enzymatic reaction. However, the need for in vivo sensing systems is well recognized. Work on in vivo sensing systems for both glucose and lactate has confirmed the effectiveness of phospholipid copolymers in

improving hemocompatibility. Fisher, U., et al. *Biosen. Bioelectron.*, 10, xxiii (1995).

[0008] By their nature, implantable sensors must have some mechanism for communicating sensed information from the sensor to a reader, which may be human or machine, outside the body. Since it is impractical to implant a physical connection between the sensor and the external reader, alternative means for generating a readable signal external the body must be provided. Suitable means for generating a readable signal external the body include, without limitation, radiographically visible signals, magnetic flux signals, chemical signals, chemifluorescent signals, and/or electrical signals.

[0009] The pathogenesis of arteriosclerosis has not been positively identified. A number of risk factors, such as high cholesterol, hypertension, and diabetes are known to serve to turn on inflammatory mechanisms at the arterial wall and recruit white cells into the arterial wall to ultimately cause the formation and breakdown of plaque, which, in turn, lead to clinical events. The process starts out with oxidation-sensitive nuclear regulatory mechanisms. Free radicals control the genes that cause the synthesis of proteins that are expressed in the endothelial cells and serve to attract white cells into the arterial wall.

[0010] Endothelialization of an implanted medical device has been the subject of considerable scientific study and literature. It is known that various growth factors and cytokines are responsible for activating smooth muscle cell receptors and initiating smooth muscle cell proliferation. Endothelial cell growth factors such as fibroblast growth factor (FGF) and vascular endothelial growth factor (VEGF) have been identified as significant for endothelial cell growth in vitro. While VEGF is specific for endothelial cells, FGFs also stimulate smooth muscle cell growth. Bauthers, C., *Growth Factors as a Potential New Treatment for Ischemic Heart Disease, Clin. Cardiol.* 20:11-52-11-57 (1997).

[0011] It has been recognized that there is a need for an in vivo sensor capable of sensing binding of endothelial cells or arteriosclerotic plaque, and providing an ex vivo detectable signal, without requiring external or internal power sources.

SUMMARY OF THE INVENTION

[0012] In accordance with the present invention there is provided an implantable in vivo sensor suitable for monitoring clinically significant physiological events. The present invention provides an integrated device which is implantable within an anatomical passageway, such as a blood vessel, in the esophageal or gastro-intestinal tract, bile duct, hepatic duct, within the renal system, such as within a ureter or urethra, vagina or cervix, vas deferens, bronchi or similar anatomical passageways; within an organ, or within an anatomical defect, such as a cardiac septal defect.

[0013] The inventive in vivo sensor consists generally of an implantable substrate carrier element and at least one of a plurality of sensor elements. The implantable substrate carrier element may consist of, for example, a stent, stent-graft, graft, valve, filter, occluder or other implantable medical device, which serves as a foundational element for the sensor elements. Under conditions where the implant-

able substrate carrier, itself, is configured to return a detectable signal, the implantable carrier element, itself, may constitute the sensor element. Where the implantable substrate carrier element and the sensor element are discrete, conjoined elements, they may be fabricated of like materials or of dissimilar materials, each having either similar or dissimilar thermal, mechanical, electrical and/or chemical properties.

[0014] Microfabrication techniques are preferably employed to create both the carrier element and the sensor element in such a manner that both the substrate carrier element and the sensor element have a defined geometry and conformation that is suitable for use as a thermal, electrical, mechanical or chemical sensor, for sensing, for example, fluid flow, fluid flow rate, or fluid pressure in the region of the sensor. The addition of chemical or biological compounds to inventive sensor permits the device to be used as either a chemical or a biosensor, respectively. Similarly, microelectronic circuits may be added to the inventive sensor, such as by fabricating integrated circuits into or onto the inventive sensor, to enable the sensor to detect electrochemical events occurring at the sensor, such as arteriosclerotic plaque being deposited onto the surface of the sensor, or to detect electrochemical changes in the anatomical environment into which the sensor is implanted.

[0015] Alternatively, the inventive implantable sensor element and the implantable substrate carrier element may be fabricated of wrought materials, such as stainless steel hypotubes, stainless steel wire, shape memory hypotubes and shape memory wires. The sensor element may be attached to the substrate carrier element, or component parts, such as cantilever members, of the sensor element may be attached to the sensor element by a variety of known means. For example, welding processes may be used, such as laser welding, plasma welding, resistance welding, or e-beam welding. Welding, however, is generally not an acceptable method for joining nickel-titanium alloys to other materials, e.g., stainless steel, because brittle intermetallics may be formed in the weld zone. In order to obtain a weld that is free of oxides or nitrides, welding should be performed under stringent environmental conditions in a clean, inert atmosphere or in vacuum in order to minimize reactivity of the titanium. In some cases, welded nickel-titanium parts may require heat-treating after welding to stress relieve the weld zone. The heat-affected zone will generally not exhibit superelastic properties. Soldering may be employed to join shape memory or superelastic alloys, such as nitinol, to stainless steel and other materials. However, a proper flux must be selected which inhibits the formation of surface oxides during the soldering process. Ultrasonic soldering has also been used to try to keep the surface free of oxides during soldering. Various epoxies and other adhesives may be used to join shape memory alloys either to themselves or to other materials. The chosen adhesives must, of course, be compatible with both the manufacturing and in vivo biological environments of the device. Finally, the sensor element may be mechanically joined to the substrate carrier element, or component parts of the sensor element may be joined together by crimping, providing an interference fit or by creating interlocking geometries of the sensor element or its component parts.

[0016] In accordance with a particular embodiment of the present invention, an endoluminal implant is provided which

is implantable within an anatomical or non-anatomical body passageway to determine a given condition of a fluid flow through the endoluminal implant within the body passage. The inventive endoluminal implant may include, for example, an endoluminal stent, stent graft, or graft that consists of a generally tubular shaped member having two diametric states. In order to facilitate transluminal catheter introduction, the inventive endoluminal device has a first diametric state in which the transverse cross-sectional area of the device is of sufficient size to permit percutaneous introduction and in vivo placement of the device using transluminal approaches. A second diametric state has a transverse cross-sectional area which is larger than the first diametric state and conforms to the diameter of the anatomical passageway into which the device is placed, or is of a desired diameter for non-anatomical passageways. The inventive endoluminal device may be fabricated as a balloon expandable device, a self-expanding device, a shape-memory device or a superelastic device. It will be understood by those of skill in the art that the term "balloon expandable" refers to a class of devices which rely upon application of an external pressure, such as that applied by a balloon catheter, to radially deform the device from its first diametric state to its second diametric state; that the term "self-expanding" refers to a class of devices which rely upon the inherent mechanical properties of the device material to expand the device from its first diametric state to its second diametric state; that the term "shape-memory" refers to a class of devices which are fabricated of materials which exhibit martensitic phase transformation at certain transition temperatures; and the term "superelastic" refers to a class of devices which are fabricated of materials which deform under given stress-strain conditions. The inventive endoluminal sensor may be fabricated of materials capable of undergoing elastic or plastic deformation, such as stainless steel, tantalum, titanium, gold, or other biocompatible metals. However, the present invention is preferably fabricated of a shape-memory and/or superelastic material, such as nickel-titanium alloys known as Nitinol, which are mechanically responsive to temperature changes and/or changes in applied stress or strain, respectively.

[0017] Generally, the inventive endoluminal sensor consists of a sensor which is integral with an implantable endoluminal device, such as stent, and which is configured to respond either mechanically, electronically, electromechanically, or chemically, to cause a mechanical, electrical, electromechanical or chemical change at the sensor and/or the endoluminal device which is detectable ex vivo using non-invasive detection methodologies such as radiography, ultrasonography, magnetic resonance imaging, or radio frequency detection.

[0018] In accordance with one embodiment of the invention, the inventive sensor comprises at least one integral region of the implantable endoluminal device that is formed as a plurality of cantilever members fabricated of shape-memory materials having different transformation temperatures. The sensor may be positioned on either a fluid contacting or tissue-contacting surface of the implantable device, such as the luminal surface of a stent which contacts blood, or on the abluminal surface of a stent which contacts neointimal tissue of the blood vessel. Alternatively, the sensors may be positioned on both the fluid contacting and the tissue-contacting surface of the implantable device.

[0019] As used herein, the term "integral" is intended to include regions that are formed as a part of the bulk material of the endoluminal device and regions which are formed separately from the bulk material of the endoluminal device, but which are coupled thereto.

[0020] In accordance with another embodiment of the invention, the inventive sensor comprises at least one region of the implantable endoluminal device that is formed of a plurality of cantilever members having different mechanical properties, such as different modulus of elasticity, plasticity or stress-strain behaviors. In accordance with the best mode presently contemplated for the invention, the cantilever members are preferably fabricated of a superelastic material. As with the shape-memory cantilever members, the superelastic cantilever members may be positioned on either a fluid contacting or tissue contacting surface of the implantable device, such as the luminal surface of a stent which contacts blood, or on the abluminal surface of a stent which contacts neointimal tissue of the blood vessel. Alternatively, the sensors may be positioned on both the fluid contacting and the tissue-contacting surface of the implantable device. Unlike the shape-memory cantilever sensors, the superelastic cantilever sensors are responsive to changes in force, such as shear forces, applied to the sensors.

[0021] With both the shape-memory cantilever members sensor and the superelastic cantilever members sensor, each of the plurality of cantilever members have first and second positions that are indicative of either an off or on position, respectively. The first or "off" position of each cantilever members is coplanar or flush with the surface of the endoluminal device into which the sensor is positioned. In the second or "on" position, each activated cantilever members projects outwardly from the surface of the endoluminal device into which the sensor is positioned. Because different cantilever members or groups of cantilever members are fabricated to have either different transition temperatures or different stress-strain properties, individual cantilever members or groups of cantilever members which are in the second or "on" position, are indicative of a given thermal or stress-strain condition existing within the body into which the endoluminal device is implanted.

[0022] In one particular form of the invention, the inventive endoluminal device comprises a temperature sensor having a plurality of cantilever members positioned on at least one of the proximal, distal or intermediate regions of the endoluminal device and positioned on at least one of the luminal or abluminal wall surfaces of the endoluminal device. To facilitate ease of detection, a plurality of groups of cantilever members are provided, each group is formed of a plurality of individual cantilever members, with each individual cantilever members in the group having identical transition temperatures. The plurality of groups of cantilever members are arrayed along the longitudinal axis of the endoluminal device in such a manner as to create a continuum of groups of cantilever members having different transition temperatures. Changes in temperature at the site of the endoluminal device are indicated by the position of the cantilever members or groups of cantilever members as determined by radiography, ultrasonography, magnetic resonance imaging or other means that provides a detectable image of the position of the cantilever members and groups of cantilever members.

[0023] In another particular form the invention, the sensor comprises a plurality of cantilever members positioned on at least one of the proximal, distal or intermediate regions of the endoluminal device and positioned on at least one of the luminal or abluminal wall surfaces of the endoluminal device. To facilitate ease of detection, a plurality of groups of cantilever members are provided, each group is formed of a plurality of individual cantilever members, with each individual cantilever members in the group having identical transition temperatures. The plurality of groups of cantilever members are arrayed along the longitudinal axis of the endoluminal device in such a manner as to create a continuum of groups of cantilever members having different stress-strain transition pressures. Changes in applied stress or strain, such as blood pressure or blood flow shear stress, at the site of the endoluminal device are indicated by the stress and strain acting on the cantilever members or groups of cantilever members which provides a corresponding frequency shift in energy reflected, when compared to a baseline stress-strain for unloaded cantilever members. The position and frequency shift of the cantilever members may be determined by radiography, ultrasonography, magnetic resonance imaging or other means which provides a detectable image of the position of the individual cantilever members and groups of cantilever members or is capable of measuring frequency shifts due to differential stress-strain loading onto the cantilever members.

[0024] In yet another form of the invention, the inventive sensor is a biosensor that is microfabricated from a material capable of undergoing elastic, plastic, shape-memory or superelastic deformation, and has a plurality of cantilever members formed therein, as described above. Each of the plurality of cantilever members has at least one binding domain selective for at least one indicator of endothelialization selected from the group of endothelial cell surface proteins, antigens, antibodies, cytokines, growth factors, co-factors, or other biological or biochemical marker of endothelial cells or endothelial cell precursors. Binding of the at least one indicator to at least one of the plurality of cantilever members causes a change in strain applied to the cantilever members, thereby causing the relevant cantilever members or groups of cantilever members to undergo superelastic transformation from the first or "off" position to the second or "on" position. As with the above-described embodiments of the invention, the position of the sensor cantilever members in the second or "on" position relative to the endoluminal device is then detected and is indicative of the progress of endothelialization.

[0025] Similarly, the fact of or the progress of arteriosclerotic plaque formation may be sensed using a plurality of elastic or superelastic cantilever members. In accordance with a first embodiment, the plurality of superelastic cantilever members undergo martensitic transformation as a result of the strain applied to the cantilever members resulting from growth of arteriosclerotic plaque onto the cantilever members. In accordance with a second embodiment, the plurality of superelastic cantilever members has at least one binding domain selective for at least one indicator of arteriosclerotic plaque or its precursors. Binding of the arteriosclerotic plaque or precursors of arteriosclerotic plaque to the binding domain on the cantilever members, adds a quantum of strain to the cantilever members sufficient to cause the cantilever members to undergo superelastic transformation from the first or "off" position to the second

or "on" position. As with the above-described embodiments of the invention, the position of the sensor cantilever members in the second or "on" position relative to the endoluminal device is then detected and is indicative of the progress of arteriosclerosis.

[0026] Yet another form of the invention entails an implant fabricated of a superelastic material that has a variable diametric geometry responsive to changes in pressure applied to the implant. This form of the invention is preferably employed as a smooth muscle prosthesis, for example, as a vascular prosthesis, and is responsive to blood pressure changes in a manner similar to those changes native to blood vessels, i.e., contracting upon sensing lowered blood pressures and expanding upon sensing higher blood pressures, in order to maintain physiologically normal blood pressure. In this embodiment of the invention, a tubular implant is fabricated, in whole or in part, of a superelastic material and has diametrically adjustable regions that undergo superelastic transformation to increase or decrease the diameter of the implant upon sensing given physiological pressures within the implant.

[0027] Finally, another form of the invention consists of an endoluminal implant similar to that described in co-pending, commonly assigned U.S. Patent Application Ser. No. 60/064,916, filed Nov. 7, 1997 which was published as PCT International Application WO9923977A1 entitled Intravascular Stent And Method For Manufacturing An Intravascular Stent, both of which are hereby incorporated by reference. In those applications there is described an endoluminal implant having a plurality of microgrooves on the luminal and/or abluminal surfaces thereof which facilitate improved endothelialization over a non-grooved endoluminal implant. In accordance with the present invention there is provided an endoluminal implant having a plurality of putative microgrooves comprising sections of weakened bulk material of the endoluminal implant. The endoluminal implant is preferably fabricated of a superelastic bulk material and weakened regions in the bulk material are formed using standard microlithographic techniques to form the putative microgrooves. A plurality of binding domains are created along the fluid flow surface of the endoluminal implant and at proximal (relative to the blood flow) regions of the putative microgrooves that preferentially bind to endothelial cell surface proteins. Binding of the endothelial cell surface proteins to the binding domains causes a shift in the applied strain to the superelastic bulk material, which causes the superelastic bulk material to deform in the region of the applied strain, thereby breaking the interatomic bonds in the weakened regions of the putative microgrooves and causing formation of a portion of a microgroove. Propagation of the endothelial cell proliferation along the surface of the superelastic bulk material causes, in turn, a propagation of strain along the superelastic bulk material that causes the formation of the microgrooves in the superelastic bulk material.

[0028] These and other objects, features and advantages of the present invention will become more apparent to those of ordinary skill in the art from the following more detailed description of the preferred embodiments of the present invention taken with reference to the accompanying figures.

BRIEF DESCRIPTION OF THE FIGURES

[0029] FIG. 1 is a perspective view of an endoluminal implant in accordance with the present invention.

[0030] FIG. 2 is a cross-sectional view taken along line 2-2 of FIG. 1.

[0031] FIG. 3 is a fragmentary plan view of a first embodiment of the present invention illustrating an integral sensor formed of a plurality of cantilever members.

[0032] FIG. 4 is a cross-sectional view taken along line 4-4 of FIG. 3.

[0033] FIG. 5 is a perspective view of an endoluminal implant in accordance with a second embodiment of the present invention.

[0034] FIG. 6 is a fragmentary plan view of a diametrically adjustable region of the second embodiment of the present invention.

[0035] FIG. 7A is a perspective view of the second embodiment of the inventive endoluminal implant of the present invention in its diametrically reduced state.

[0036] FIG. 7B is a perspective view of the second embodiment of the inventive endoluminal implant of the present invention in its diametrically expanded state.

[0037] FIG. 8 is a perspective view of a third embodiment of the inventive endoluminal implant of the present invention depicting weakened regions in the bulk material in phantom.

[0038] FIG. 9 is a fragmentary enlarged plan view of circled region 9 in FIG. 8.

[0039] FIG. 10 is a fragmentary plan view illustrating propagation of a microgroove upon binding of an endothelial cell to a binding domain at the weakened region in the bulk material of the third embodiment of the present invention.

DETAILED DESCRIPTION OF THE PREFERRED EMBODIMENTS

[0040] To simplify description of the present invention, most of the preferred embodiments will be described with reference to an endoluminal stent, except where otherwise stated. However, those of ordinary skill in the art will understand that each embodiment has application to a variety of implantable devices including, without limitation, stents, grafts, stent-grafts, valves, shunts or patches.

[0041] The particular means for detecting a change in the inventive sensor and/or the particular means for activating a change in the inventive sensor is generally not considered part of the present invention. For example, it is known that ultrasound energy may be employed to generate both one-way and two-way shape memory effects in nickel-titanium alloys. V. V. Klubovich, V. V. Rubanick, V. G. Dorodeiko, V. A. Likhachov, and V. V. Rubanick Jr. (Institute of Tech. Acoustics, 13 Ludnikova, 210026 Vitebsk, Belarus,) *Generation of Shape Memory Effect in Ti—Ni Alloy by means for Ultrasound*, Abstract 1.P12, SMST-97 conference found at URL <http://www.fvsystems.com/professional/srstabs.html>. Using ultrasound energy to non-invasively induce stent heating has also been confirmed by B. Lal, et al. in their abstract entitled *Non-Invasive Ultrasound Induced Heating of Stents: Importance of Stent Composition*, which may be found at URL <http://www.hotplaque.com/frames/abstracts/rabs6.htm> and URL <http://ex2.excerptamedica.com/00acc/abstracts/abs1065-117.html>. Lal, et al. hypothesized that

gentle heating can be accomplished using ultrasound (US) and a constant temperature can be maintained using pulsed US. The heating rate of an object under the same US power and frequency is determined primarily by its absorption and reflection rates. To test their hypothesis, they used a phantom of 5.08 cm thick layer of pork muscle, in which various annular stent shape materials were placed. To monitor the heating multiple hypodermic thermocouples were used. The heating was induced using FDA-approved levels of therapeutic ultrasound (intensity 0.5-2.5 W/cm², frequency 1-3 MHz) in both pulse and continuous modes. It was found that nylon, and some types of PVC, exhibit temperature increases that are larger (2-35° C.) and faster (1.5-15 times) than the surrounding tissue, while Lexan, PTFE, Latex, Teflon, Ceramic and Delrina do not display selective heating. A modest heating effect (2° C. increase in 15 minutes) was also found in a metal stent. Lal, et al. concluded that ultrasound heating of tissue adjacent to a prosthesis depends on stent composition, induction of thermal apoptosis by ultrasound may prove to be effective in limiting restenosis in polymeric stents and grafts. Issues that need to be addressed include the optimal biocompatible material and design of stents and the in vivo effects of phased-array US on the stented artery and its surrounding tissues. Lal, et al. believed that by using fast-heating, non-toxic materials, ultrasound-heated stents could be devised.

[0042] Similarly, microwave radiation may be used to generate shape memory effects in shape memory alloys. It is known, for example, that microwave radiation may be used for stent diathermy in stainless steel stents. S. Naguib, et al. in *Stent diathermy using focused ultrasound & microwave* found at URL <http://www.hotplaque.com/frames/abstracts/rabs3.htm> sought to use ultrasound and microwave energy to non-invasively heat the stent and its surrounding plaque. Using Palmaz-Schatz stents as well as several stent-shape biopolymer materials embedded inside the phantom, Naguib, et al. continuously mapped rise in temperatures in the system upon ultrasound and microwave irradiations in separate settings. Temperature monitoring was done using a 12-channel ultra-thermometer (0.01° C.) with thermocouples (ultrasound) and fiber optic sensors (microwave). Therapeutic ultrasound at the frequency of 1-3 MHz and intensity of 0.5-2.5 W/CM² was used. Microwave radiofrequency was delivered by an antenna using a frequency of 2.45 GHz and a power of 5.37 & 10.22 watts. In their ultrasound experiment Naguib, et al. found that the temperature of outer surface of stent and its surrounding tissue increased significantly higher than other sites. The rise in temperature varies by the type of biopolymer where silicon stent heated faster and more than polyurethane and polytetrafluoroethylene. Similar results were observed in the microwave experiments. Infrared thermography was used to measure the increased temperatures during delivery of both ultrasound and microwave radiation.

[0043] It is recognized, however, that externally applied forces, such as RF, microwave, ultrasound, etc. exist in the ambient environment. It is, therefore, undesirable to fabricate sensor device which will undergo a shape memory change upon encountering an ambient externally applied force. For example, it would be undesirable for a patient with an implanted sensor device responsive to microwave irradiation to have the implanted sensor device undergo a shape memory transition when the patient is warming food in a kitchen microwave appliance.

[0044] Because the microfabrication methods of the present invention allow for stringent control over the material composition of the implantable sensor device, the material composition may be made responsive to a particular frequency range that is outside the frequency range of the same type of energy signals existing in the ambient environment of the patient. Thus, both the device activation energy type and frequency and the detection energy type and frequency must fall outside that encountered in the ambient environment.

[0045] It is well known that metal stents are radioopaque and are detectable under radiographic imaging, such as fluoroscopy. Detection of the inventive sensor device may be accomplished by radiographic imaging, ultrasound imaging (either using frequencies which also generate a shape memory effect or not), magnetic resonance imaging, RF imaging or similar methods. The use of magnetic resonance imaging to image nitinol stents is known in the art. See, e.g., Rahdert, D, Hakim, B., *Magnetic Resonance compatibility of Ni—Ti Stents*, Abstract 8.P1, SMST-97 conference (International Organization on Shape Memory and Superelastic Technologies) found at URL <http://www.fwsystems.com/professional/smstabs.html>, in which they describe they studied the compatibility of Ni—Ti coronary stents using magnetic imaging to assess a) ferromagnetic forces; and b) artifacts. Two methods were used to measure force: horizontal sliding and pendulum deflection. Ferromagnetic forces were found to be less than 10% of stent weight. Artifacts were assessed to be small.

[0046] The use of particulate paramagnetic metal iron oxide as a contrast medium to image and model vascular profiles under magnetic resonance imaging (MRI) has been demonstrated by Mitra Rajabi, et al. at the University of Texas-Houston, Houston, Tex., United States and the University of Texas-Medical Branch at Galveston, Galveston, Tex., United States. In an abstract published for presentation at the ACC 2001, the American College of Cardiology Scientific Session scheduled for Mar. 18-21, 2001, the abstract may be found at URL: <http://www.hotplaque.com/ACC/ACC2001%20abstracts.htm#5>, Rajabi, et al. describe a technique for imaging plaque inflammation. Super paramagnetic iron oxide (SPIO) particles are magnetic resonance (MR) imaging contrast media that have a central core of iron oxide generally coated by a polysaccharide layer. They shorten the relaxation time, predominantly the T2 relaxation time. Rajabi, et al. hypothesized that inflamed vulnerable arteriosclerotic plaques would preferentially take up these nano-particles by virtue of macrophage infiltration, leaking vasa vasorum and fissured thin caps. To test their hypothesis, they injected 1-3 mmol Fe/kg super paramagnetic iron oxide to six Apo E deficient and two C57b1 mice through the tail vein, after first obtaining baseline MR imaging. Post-contrast MR imaging were performed in day 5 with the same parameters (TR=2.5, TE=0.012, FOV=6 6, slice thickness=2.0 mm, flip angle (orient)=trans, and matrices=256x256). The aorta at the level of kidney was selected for comparison of the baseline and post-contrast images. Rajabi, et al. found decreased signal intensity in SPIO injected Apo E deficient mice and no decrease in signal intensity in SPIO injected C57b1 mice.

[0047] Thus, it is known in the art that thermal energy may be imparted to implanted medical devices fabricated of metal either by transcatheter approaches using direct appli-

cation of heat, such as by a laser catheter, or may be induced by directing microwave or ultrasound energy toward the implanted device. Moreover, it is known implanted medical devices fabricated of shape memory alloys may be detected in vivo using radiography, ultrasonography, MRI, or RF imaging or combinations thereof.

[0048] In accordance with the present invention, any of the foregoing methods of applying energy to the inventive sensor device, either directly through transcatheter application or indirectly through inductive methods, as well as any of the foregoing methods for detecting the state of the inventive sensor device in vivo may be employed to effectuate change in the state of the implanted device. The energy stimulus may be an endogenous energy stimulus selected from the group consisting of fluid pressure, fluid shear forces, body temperature, cellular binding or molecular binding. Alternatively, the energy stimulus may be an exogenous energy stimulus such as externally applied temperature, pressure, microwave, ultrasound, RF, ultraviolet, infrared, magnetic resonance, x-rays, beta or gamma irradiation.

[0049] Turning now the accompanying Figures, and in particular **FIGS. 1-4** there is illustrated first and second embodiments of implantable in vivo sensor in accordance with the present invention.

Temperature Sensor

[0050] The inventive in vivo temperature sensor **10** consists generally of an implantable tubular member **12** having a central lumen **14**, an abluminal wall surface **16**, a luminal wall surface **18** and at least one of a plurality of sensor regions **20** integral with at least one of the abluminal wall surface **16** and the luminal wall surface **18** of the implantable tubular member **12**. The flow vector **F** of a fluid over the surface of the sensor region **20** is illustrated in **FIG. 3**. Each of the at least one of a plurality of sensor regions further comprise a plurality of cantilever members **22** patterned in an array on the implantable tubular member **12**. The implantable tubular member **12**, the sensor **20** and the plurality of cantilever members may be fabricated of like materials, such as shape memory materials, or may be fabricated of different materials, e.g., the implantable tubular member **12** being fabricated of stainless steel and the sensor **20** and cantilever members **22** being fabricated of a shape memory material, such as nickel-titanium alloys. In accordance with the best mode contemplated for the present invention, the tubular member **12**, the sensor **20** and the cantilever members will be fabricated of shape memory materials, such as nickel-titanium alloys. Where each of the plurality of cantilever members **22** are fabricated of a shape memory material, either individual cantilever members **22** or groups of cantilever members **22** within a single sensor **20** may be fabricated to have different martensite transition temperatures. Thus, for example, cantilever members **22a** within sensor **20** may be fabricated to have a transition temperature of X degrees Centigrade, while cantilever members **22b** are fabricated to have a transition temperature of X+1 degrees Centigrade, cantilever members **22c** are fabricated to have a transition temperature of X+2 degrees Centigrade, etc. Alternatively all of the cantilever members **22** in a sensor **20** may have the same transition temperature, and a plurality of sensors **20** are provided such that sensor **20a** has cantilever members having a transition temperature of X degrees Centigrade, while the plurality of cantilever

members **22** in sensor **20b** are fabricated to have a transition temperature of $X+1$ degrees Centigrade, and the plurality of cantilever members **22** in sensor **20c** are fabricated to have a transition temperature of $X+2$ degrees Centigrade, etc.

[0051] Each of the plurality of cantilever members **22** may be fabricated of a material capable of undergoing elastic, plastic, shape memory and/or a superelastic deformation. Materials such as stainless steel, titanium, nickel, tantalum, gold, vanadium, nickel-titanium, or alloys thereof may be employed to fabricate the plurality of cantilever members. Different electrical, thermal or mechanical properties may be imparted to the cantilever members **22** by altering the alloy ratios of the material. It is preferable to vacuum deposit both the tubular member **12**, the sensors **20** and the cantilever members **22** to permit tight control over the material composition, electrical, mechanical and thermal properties of the material, as well as provide for tight control over the tissue and fluid contacting surfaces and the bulk material of the device. For example with nickel-titanium alloys, the titanium content of the target, in a nickel-titanium binary target, may be changed a known amount to precisely alter the transition temperature of a cantilever members.

[0052] Each of the plurality of cantilever members **22** preferably have binary functionality to provide a first "off" position indicative of an austenite phase of the cantilever members **22** and a second "on" position indicative of a martensite phase of the cantilever members **22**. The first "off" position may be configured such that it is in a raised position which projects outwardly relative to the sensor **20** and/or the tubular member or in the lowered position that is substantially co-planar with the sensor **20** and/or the tubular member **12**. Similarly, the second "on" position may be configured such that it is in a lowered position that is substantially coplanar with the sensor **20** and/or the tubular member **12** or the cantilever members **22** may be in the raised position or projecting outwardly relative to the sensor **20** and the tubular member **12**, provided, however, that the first "on" position and the second "off" positions are different from one and other.

[0053] It will be understood, therefore, that as the implanted temperature sensor encounters different in vivo temperatures, different sets of cantilever members will be exposed to their transition temperature and change from the "off" position to the "on" position. In order to detect which cantilever members are in the "on" position and, therefore, determine the in vivo thermal conditions, the temperature sensor may be imaged radiographically, ultrasonically, magnetically or may be exposed to an external energy source which returns a signal representative of the number and position of the cantilever members that are in the "on" position. The returned signal may be generated by a passive transmitter embedded in solid state circuitry defined within the sensor **20**, wherein the cantilever members **20** serve as electromechanical switches which alter a property of the solid state circuitry, for example, impedance or capacitance, and which then returns a detectable signal representative of the number and position of cantilever members **22** in the "on" position.

Pressure Sensor

[0054] Because it is structurally virtually identical to the temperature sensor **10**, described above, the inventive in vivo pressure sensor will also be described with reference to

FIGS. 1-4 and use identical reference numerals to describe the elements thereof. The inventive in vivo pressure sensor **10** consists generally of an implantable tubular member **12** having a central lumen **14**, an abluminal wall surface **16**, a luminal wall surface **18** and at least one of a plurality of sensor regions **20** integral with at least one of the abluminal wall surface **16** and the luminal wall surface **18** of the implantable tubular member **12**. Each of the at least one of a plurality of sensor regions further comprise a plurality of cantilever members **22** patterned in an array on the implantable tubular member **12**. The implantable tubular member **12**, the sensor **20** and the plurality of cantilever members may be fabricated of like materials, such as superelastic materials, or may be fabricated of different materials, e.g., the implantable tubular member **12** being fabricated of stainless steel and the sensor **20** and cantilever members **22** being fabricated of a superelastic material, such as nickel-titanium alloys. In accordance with the best mode contemplated for the present invention, the tubular member **12**, the sensor **20** and the cantilever members will be fabricated of superelastic materials, such as nickel-titanium alloys. Where each of the plurality of cantilever members **22** are fabricated of a superelastic material, either individual cantilever members **22** or groups of cantilever members **22** within a single sensor **20** may be fabricated to have different martensite transition temperatures. Thus, for example, cantilever members **22a** within sensor **20** may be fabricated to have a martensitic stress/strain transition coefficient σ , while cantilever members **22b** are fabricated to have a transition coefficient $\sigma+1$, cantilever members **22c** are fabricated to have a transition coefficient of $\sigma+2$, etc. such that different cantilever members **22** or groups of cantilever members **22** change their position based upon a given quantum of stress or strain applied to the cantilever members **22** in vivo. Alternatively all of the cantilever members **22** in a sensor **20** may have the same transition temperature, and a plurality of sensors **20** are provided such that sensor **20a** has cantilever members having a transition coefficient σ , while the plurality of cantilever members **22** in sensor **20b** are fabricated to have a transition coefficient of $\sigma+1$, and the plurality of cantilever members **22** in sensor **20c** are fabricated to have a transition coefficient of $\sigma+2$, etc. such that different sensors **20a**, **20b**, **20c** respond to different stress-strain conditions.

[0055] Each of the plurality of cantilever members **22** may be fabricated of a shape memory and/or a superelastic material. Different electrical, thermal or mechanical properties may be imparted to the cantilever members **22** by altering the alloy ratios of the material. It is preferable to vacuum deposit both the tubular member **12**, the sensors **20** and the cantilever members **22** to permit tight control over the material composition, electrical, mechanical and thermal properties of the material, as well as provide for tight control over the tissue and fluid contacting surfaces and the bulk material of the device. For example with nickel-titanium alloys, the titanium content of the target, in a nickel-titanium binary target, may be changed a known amount to precisely alter the transition temperature of a cantilever members.

[0056] Each of the plurality of cantilever members **22** may have binary functionality to provide a first "off" position indicative of an austenite phase of the cantilever members **22** and a second "on" position indicative of a martensite phase of the cantilever members **22**. The first "off" position may be configured such that it is in a raised position which projects outwardly relative to the sensor **20** and/or the

tubular member or in the lowered position that is substantially co-planar with the sensor **20** and/or the tubular member **12**. Similarly, the second “on” position may be configured such that it is in a lowered position that is substantially coplanar with the sensor **20** and/or the tubular member **12** or the cantilever members **22** may be in the raised position or projecting outwardly relative to the sensor **20** and the tubular member **12**, provided, however, that the first “on” position and the second “off” positions are different from one and other.

[0057] Alternatively rather than having merely binary functionality, each of the plurality of cantilever members **22** may have a response curve which is dependent upon the modulus of the material and the moment of inertia of each cantilever member. Each of the cantilever members **22** may be configured to have a variation in Z-axis thickness along an X-Y axis of the cantilever member **22**. By configuring the cantilever members **22** with variable Z-axis thicknesses, different cantilever members **22** or different groupings of cantilever members will exhibit different stress-strain responses due to the different material modulus and different moment of inertia attendant to the altered geometry of the cantilever member **22**. With this alternate construct of the cantilever members **22**, for a given quantum of stress-strain applied to the cantilever members **22**, the cantilever members **22** will deflect and shift a returned resonance frequency applied from an external energy source. The degree of deflection will then correlate to the stress and strain forces acting upon the cantilever members **22**. It will be understood, of course, that this alternate construct of the cantilever members **22** still provides binary “on” and “off” functionality with the “on” and “off” positions merely being indicative of the outlying positions of the cantilever member **22**.

[0058] It will be understood, therefore, that as the implanted pressure sensor encounters different stress and strain associated with, for example, changes in physiological blood pressure, fluid shear stress, endothelialization, arteriosclerotic plaque development, different sets of cantilever members will be exposed to their transition conditions and change from the “off” position to the “on” position. In order to detect which cantilever members are in the “on” position and, therefore, determine the stress-strain conditions, the pressure sensor may be imaged radiographically, ultrasonically, magnetically or may be exposed to an external energy source which returns a signal representative of the number and position of the cantilever members that are in the “on” position. The returned signal may be generated by a passive transmitter embedded in solid state circuitry defined within the sensor **20**, wherein the cantilever members **20** serve as electromechanical switches which alter a property of the solid state circuitry, for example, impedance or capacitance, and which then returns a detectable signal representative of the number and position of cantilever members **22** in the “on” position.

[0059] With both the temperature sensor and pressure sensor embodiments, the cantilever members **22** may also be insulated from either the implantable tubular member **12** or from the sensor region **20**. Thermal or electrical insulators may be positioned intermediate the sensor region **20** and the implantable tubular member **12** to insulate the implantable tubular member **12** from heat or electrical transfer from the cantilever members **22** to the implantable tubular member **12**.

Vascular Imaging Sensor

[0060] We turn now to **FIGS. 5-7B**, in which there is illustrated the inventive in vivo sensor device **30** in the form of an endoluminal stent adapted for non-invasive vascular modeling and imaging. The inventive in vivo sensor device **30** comprises a plurality of structural elements **32, 36** that serve to define walls of the sensor device **30**. The particular geometry of the plurality of structural elements **32, 36** may be selected based upon the intended function of the sensor device **30**, e.g., a stent or stent-graft, and is not a significant factor in the present invention. It will be appreciated by those of ordinary skill in the art that alternative geometries of the structural elements **32, 36** other than those depicted in the Figures are contemplated by the present invention. The plurality of structural elements **32, 36** which define the sensor device **30** are fabricated of at least one of a shape memory materials, superelastic materials, plastically deformable materials and/or elastically deformable materials, such as stainless steel and/or nickel-titanium alloys, that permit the sensor device **30** to expand within an anatomical passageway, for example a blood vessel, at body temperature, i.e., the martensite transition temperature (in the case of a shape memory material) is below, but in proximity to, body temperature. In order to provide sensor functionality and permit vascular imaging and modeling, the inventive sensor **30** further comprises regions of the structural elements **32, 36** which have a second shape memory and/or superelastic material therewith (hereinafter the “second material”), which has, for example, a martensite transition temperature (or σ coefficient) which is higher than that of the base material for the structural elements **32, 36**. Having a second material with either a higher transition temperature or a higher σ coefficient, allows for changing device **30** geometry or conformation upon application of internally or externally applied forces. For example, heat energy may be applied by either external microwave transmissions directed from outside the body to the device **30** or by a laser catheter that is used to apply laser energy to the sensor device **30**. In either case, localized heating of the sensor device **30** to above the transition temperature of the second material causes the structural elements **32, 36** to undergo martensitic transformation with a concomitant change to the geometry and/or conformation of the sensor device **30**. Upon martensitic transformation, at least some of the structural elements **32, 36** will change their positioning relative to the geometry of the sensor **30**, as represented by arrows **38** in **FIG. 6**, thereby changing the configuration of openings **37** between adjacent pairs of structural elements **32, 36**. The sensor **30** in its changed geometry and/or conformation may then be imaged using conventional non-invasive imaging techniques to provide an image of the vascular profile.

[0061] After retrieving a diagnostic image of the vascular profile, it may be necessary to remodel either the geometry or conformation of the sensor device **30**. For example, the device **30** may require elongation or diametric enlargement (as depicted in **FIGS. 7A and 7B**). In order to remodel the sensor device **30**, a superelastic material may be included in some of the structural elements **32, 36** which is responsive to externally applied forces, e.g., ultrasound, irradiation, microwave, ultrasound, RF, ultraviolet, infrared, magnetic resonance, x-rays and gamma irradiation, which will alter the stress-strain applied to the sensor device **30**, causing a

martensitic transformation in those portions of the structural elements **32**, **36** and a concomitant change in the conformation of device **30**.

[0062] Additionally, because thermal changes in the sensor device **30** may be induced by externally applied force, it is possible to both thermally heat, and thermally cool the sensor device **30**. Ex vivo cooling may be accomplished by dampening the molecular vibrations induced by an external energy source, such as by shifting the frequency of the excitatory signal by 180 degrees. By dampening the molecular vibrations, a cooling effect may be generated in the sensor device **30** in order to induce localized cooling in the region of the sensor device **30**.

Endoluminal Sensor

[0063] Also with reference to **FIGS. 4-7B** there is illustrated a sensor device **30** which comprises a generally tubular member having a plurality of wall elements **32**, **36** that define walls of the sensor device **30**. The plurality of wall elements are preferably fabricated of shape memory or superelastic materials such that the endoluminal sensor device **30** effectively has at least two martensite transition points. Conventional shape memory and superelastic materials have a single martensite transition point. However, by fabricating all of the wall elements **32**, **36** of laminates of shape memory or superelastic materials such that one ply has a martensite transition point of T_1 and a second ply has a martensite transition point of T_2 wherein $T_2 > T_1$, the first ply will cause the sensor device **30** to transition at T_1 which corresponds to the condition for normal in vivo physiological conditions, while the an additional quantum of energy, such as externally applied microwave, ultrasound, RF energy or internally applied energy, such as laser irradiation or direct thermal contact, will induce the condition suitable for transition at T_2 and the device will undergo a second shape transition. Alternatively, portions of the wall elements **32**, **36** may be fabricated of a first material having a transition point T_1 , while other portions of the wall elements **32**, **36**, which are preferably non-structural for the sensor device **30** under the T_1 conditions, but are structural for the sensor device **30** under T_2 conditions, are fabricated of a second material having a transition point T_2 . Thus, those wall elements **32**, **36** fabricate of the T_1 material will cause the sensor device **30** to transition into an initial endoluminal shape or geometry under the conditions appropriate to achieve transition point T_1 , while those wall elements **32**, **36** fabricated of the T_2 material will not transition until the appropriate conditions for transition point T_2 are applied to the sensor device **30**.

Endothelialization BioSensor

[0064] Turning now to **FIGS. 8-10** there is illustrated a biosensor **40** for sensing endothelialization events at the tissue-contacting surface of the sensor device. Like the inventive in vivo sensor devices described above, the inventive biosensor **40** consists generally of an implantable substrate carrier **42** having tissue contacting surfaces **42**, **46** thereupon. For purposes of illustration only, biosensor **40** is depicted with the implantable substrate carrier **42** being of a generally tubular configuration, such as for example, as stent. A plurality of binding regions **50** are defined on either of the tissue contacting surfaces **42**, **46**. The binding regions **50** are similar to the sensor regions of the above-described embodiments, except the binding regions **50** comprise

regions of the implantable substrate carrier **42** which have biochemical markers, such as antibodies or ligands, bound thereto which are specific for endothelial and/or smooth muscle cell surface proteins or precursors of endothelial cell and smooth muscle cell proliferation, such as vascular endothelial growth factor or other growth factors. The material of the implantable substrate carrier **42** is preferably fabricated of a shape memory or superelastic material, which, upon binding of biological material to the biochemical markers in the binding regions **50**, undergoes phase transformation due either the binding to the biochemical markers alone or in combination with an applied energy to the bound complex. The phase transformation of the material of the implantable substrate carrier **42** will cause a frequency shift in a returned signal from the applied energy source and will be indicative of the bound state of the binding domains **50**.

[0065] With particular reference to co-pending, commonly assigned U.S. Patent Application Ser. No. 60/064,916, filed Nov. 7, 1997 which was published as PCT International Application WO9923977A1 entitled Intravascular Stent And Method For Manufacturing An Intravascular Stent, both of which are hereby incorporated by reference, the binding regions **50** may also form putative microgrooves **50** which are regions of the implantable substrate carrier **42** having patterned weakened atomic bonds in the crystalline structure of the substrate carrier **42** material. Upon binding of an endothelial cell, smooth muscle cell or a precursor thereof to the binding domain, the material of the substrate carrier **42** may either directly undergo or be induced by an external energy source to undergo a phase transformation which will cause the weakened atomic lattice of the crystalline structure of the substrate carrier **42** material to fracture and open a plurality of microgrooves **52** contiguous with the at the binding regions **50**. The microgrooves **52** may be propagated by the additional binding of biological material to the markers at the binding regions **50**. In this manner, there are self-propagating microgrooves which facilitate endothelialization of the implanted substrate carrier.

[0066] Although the present invention has been described in connection with the preferred form of practicing it, those of ordinary skill in the art will understand that many modifications can be made thereto within the scope of the claims that follow. Accordingly, it is not intended that the scope of the invention in any way be limited by the above description, but instead be determined entirely by reference to the claims that follow.

1-47. (canceled)

48. An implantable sensor device having a plurality of structural elements capable of expanding within an anatomical passageway at least some of the plurality of structural elements further comprising at least one sensor element that selectively detects an energy stimulus and responds to the detection of the energy stimulus by altering the geometry or conformational profile of the device body member.

49. The implantable sensor device according to claim 48, wherein the structural elements are fabricated of a forming material selected from the group consisting of shape memory materials, superelastic materials, plastically deformable materials, and elastically deformable materials.

50. (canceled)

51. The implantable sensor device according to claim 49, wherein the energy stimulus comprises an exogenous energy

stimulus selected from the group consisting of microwave, ultrasound, radio frequency, ultraviolet, infrared, magnetic resonance, x-rays, laser, and beta and gamma irradiation.

52. The implantable sensor device according to claim 51, wherein the exogenous energy stimulus results in localized heating in vivo.

53. The implantable sensor device according to claim 52, wherein the exogenous energy stimulus is a laser delivered by a laser catheter.

54. The implantable sensor device according to claim 49, wherein the energy stimulus is a physiological stimulus.

55. The implantable sensor device according to claim 54, wherein the physiological stimulus comprises an endogenous energy stimulus selected from the group consisting of fluid pressure, fluid shear forces, body temperature, cellular binding and molecular binding.

56. The implantable sensor device according to claim 49, further comprising a sensor element that facilitates the interaction with the energy stimulus and mediates the altering of the geometry or conformational profile of the device body member.

57. The implantable sensor device according to claim 56, wherein the sensor element comprises a plurality of sensor regions integrally defined on at least one of a luminal or abluminal surface of the device body member.

58. The implantable sensor device according to claim 57, wherein the sensor regions are fabricated of a shape memory or superelastic material so that the properties of the sensor regions differ from that of the remaining structural elements.

59. The implantable sensor device according to claim 58, wherein the sensor regions exhibit a martensitic transition temperature higher than that of the remaining structural elements.

60. The implantable sensor device according to claim 59, wherein upon the sensor regions undergoing martensitic transformation, the sensor region stimulates the remaining

structural elements to undergo martensitic transformation and effect a change in the geometry of the implantable sensor device.

61. The implantable sensor device according to claim 60, wherein the implantable sensor device displays an altered geometry that produces an image detectable using non-invasive imaging techniques.

62. The implantable sensor device according to claim 48, wherein the altered geometry or altered conformation is capable of detection by non-invasive imaging techniques.

63. The implantable sensor device according to claim 62, wherein the implantable sensor device further comprises structural elements having areas of inclusion of superelastic material, wherein the superelastic material is responsive to externally applied forces resulting in a martensitic transformation in the structural elements having areas of inclusion of superelastic material.

64. The implantable sensor device according to claim 63, wherein the externally applied forces is a force selected from the group consisting of ultrasound, irradiation, microwave, radio frequency, ultraviolet, infrared, magnetic resonance, x-rays and gamma irradiation.

65. The implantable sensor device according to claim 48, wherein the structural elements form the walls of the sensor device, the structural elements being fabricated of laminate layers of shape memory or superelastic material.

66. The implantable sensor device according to claim 65, wherein the structural elements are formed of at least two laminate layers, wherein a first laminate layer has a first martensitic transition point at normal physiological temperature and a second laminate layer has a second martensitic transition point that is greater than the first martensitic transition point.

67. (canceled)

* * * * *

专利名称(译)	在VIVO传感器及其制造方法中		
公开(公告)号	US20060074479A1	公开(公告)日	2006-04-06
申请号	US09/783633	申请日	2001-02-14
[标]申请(专利权)人(译)	BAILEY史蒂芬 - [R BOYLE CHRISTOPHER† 马顿DENES 巴尼亚斯CHRISTOPHERê		
申请(专利权)人(译)	BAILEY史蒂芬 - [R BOYLE CHRISTOPHER† 马顿DENES 巴尼亚斯CHRISTOPHERê		
当前申请(专利权)人(译)	BAILEY史蒂芬 - [R BOYLE CHRISTOPHER† 马顿DENES 巴尼亚斯CHRISTOPHERê		
[标]发明人	BAILEY STEVEN R BOYLE CHRISTOPHER T MARTON DENES BANAS CHRISTOPHER E		
发明人	BAILEY, STEVEN R. BOYLE, CHRISTOPHER T. MARTON, DENES BANAS, CHRISTOPHER E.		
IPC分类号	A61F2/06 A61B5/00 A61B5/01 A61B5/0215 A61B5/06 A61B5/07 A61B17/00 A61F2/82 A61L27/00 A61L27/04 A61L31/02 A61M1/10		
CPC分类号	A61B5/01 A61B5/0215 A61B5/076 A61B5/6862 A61B5/6876 A61F2/82 A61F2/91 A61L27/04 A61L31 /022 A61F2250/0096 A61F2310/00023 A61B5/02 A61B5/02035 A61B5/021 A61B5/02427 A61B5/0507 A61B5/055 A61B5/145 A61B5/14503 A61B5/14532 A61B5/1473 A61B5/4842 A61B5/6846 A61B6/12 A61B8/0841 A61B2562/0247 A61B2562/0276 A61B2562/12 A61B2562/164 A61F2/958 A61F2002 /4672 A61F2210/0014 A61F2210/0023 A61F2210/0042 A61F2210/0076 A61F2250/0001 A61F2250 /0004 A61F2250/0014 A61F2250/0018 A61F2250/0029 A61F2250/0035 A61F2250/0042 A61F2250 /0067 A61F2250/0068 A61F2250/0098 B23K1/19		
其他公开文献	US8372139		
外部链接	Espacenet USPTO		

摘要(译)

可植入的体内传感器，用于监测体内的物理，化学或电气参数。体内传感器与可植入医疗设备是一体的，并且响应于外部或内部施加的能量。在施加能量时，传感器在装置的至少部分材料中经历相变，然后通过诸如射线照相术，超声成像，磁共振成像，射频成像等的常规技术在身体外部检测到。本发明的体内传感器可用于提供体积测量，流速测量，压力测量，电测量，生化测量，温度，测量，或测量腔内植入物腔内沉积物的程度和类型，例如作为支架或其他类型的腔内导管。体内传感器还可以在治疗上用于响应于感测或监测的参数调节腔内植入物的机械和/或物理特性。

