



(19) **United States**

(12) **Patent Application Publication**

(10) **Pub. No.: US 2004/0006258 A1**

Meyer et al.

(43) **Pub. Date:**

Jan. 8, 2004

(54) **SENSOR ELEMENT FOR DETECTING A PHYSICAL MEASURING VARIABLE BETWEEN BODIES EXPOSED TO HIGH TRIBOLOGICAL STRAIN**

Publication Classification

(51) **Int. Cl.⁷** **A61B 5/00**
(52) **U.S. Cl.** **600/300**

(76) **Inventors:** **Klaus Meyer**, Ditzingen (DE); **Julius Nemzov**, Esslingen (DE); **Ulrich Mueller**, Herrliberg (CH)

(57) **ABSTRACT**

The invention proposes sensor elements (5) for detecting a physical measurement variable such as a pressure, a temperature, a gap width, or a capacitance between two bodies (10, 20) that move in relation to each other during operation and experience high tribological stress. In certain areas between the surfaces of the bodies (10, 20) that move in relation to each other, in a surface region of at least one of the bodies (10), a sensitive layer (13, 30), in particular a sensor segment (13), is provided, which is separated from the body (10) by an insulation layer (12) and has a covering layer (14) in a first embodiment. In an alternative embodiment, a surface region of at least one of the two bodies (10) has a recess (23) in which the sensor surface (13) is disposed on the insulation layer (12). In a third embodiment, the sensor surface (13) has a length of 10 μm to 5 mm, a width of less than 5 μm, and a thickness of less than 200 nm.

Correspondence Address:
Striker Striker & Stenby
103 East Neck Road
Huntington, NY 11743 (US)

(21) **Appl. No.:** 10/415,229

(22) **PCT Filed:** Sep. 6, 2002

(86) **PCT No.:** PCT/DE02/03310

(30) **Foreign Application Priority Data**

Sep. 8, 2001 (DE)..... 101 44 271 8

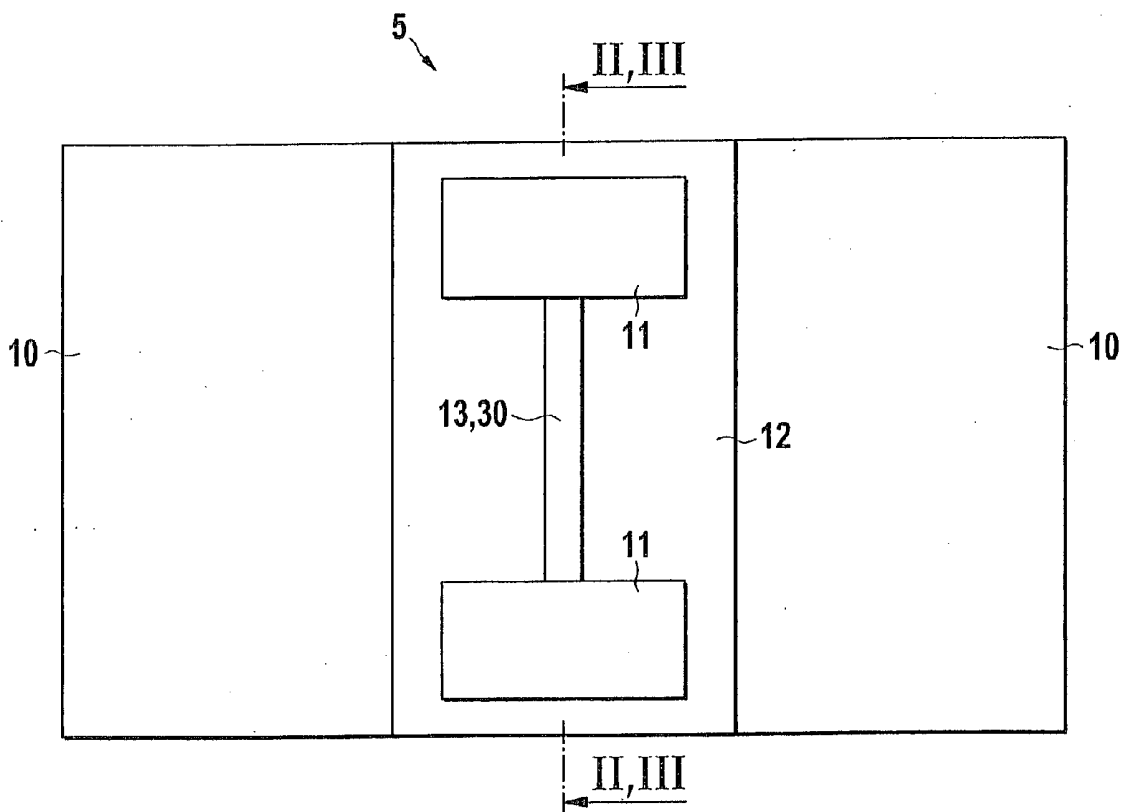

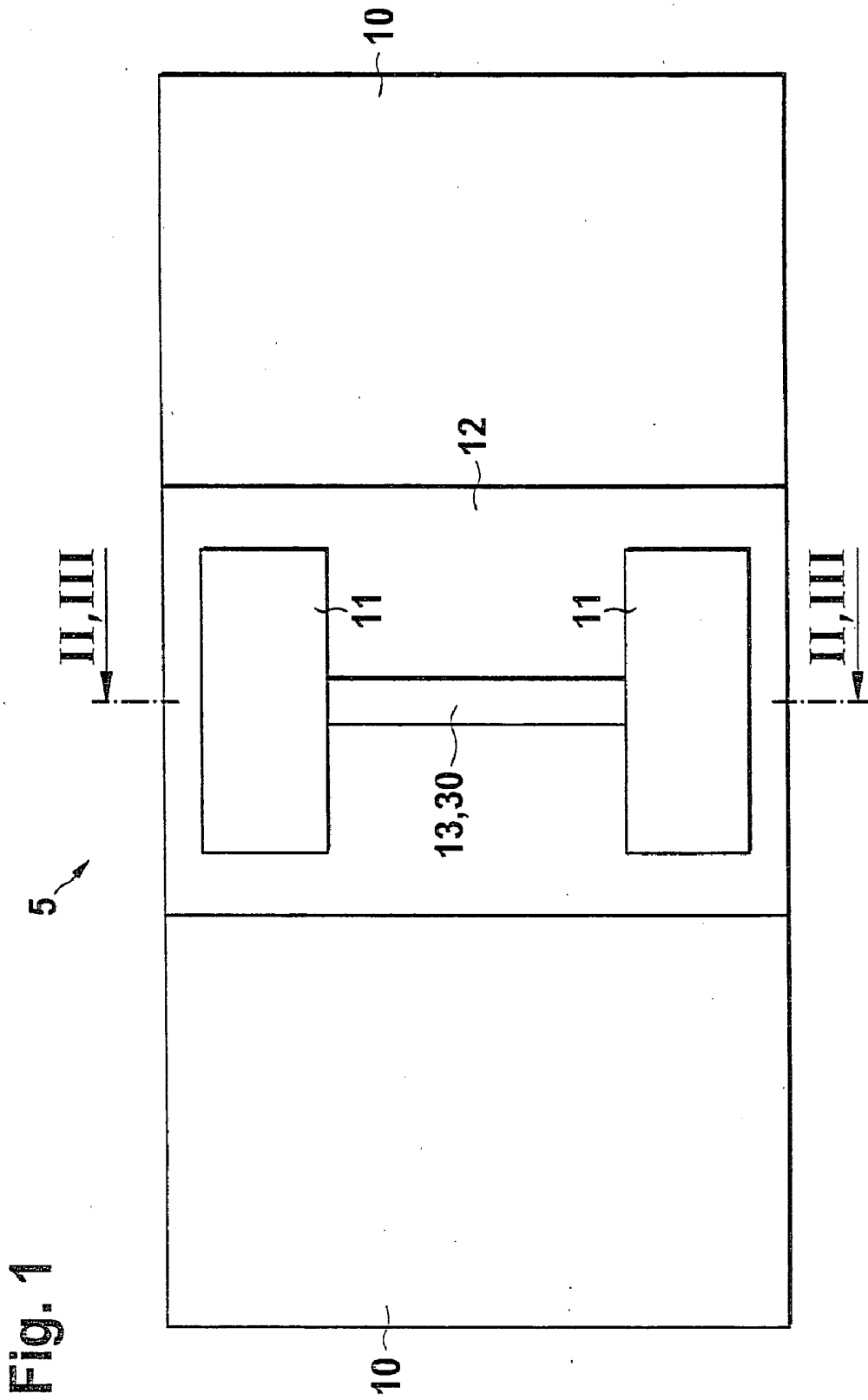

Fig. 2

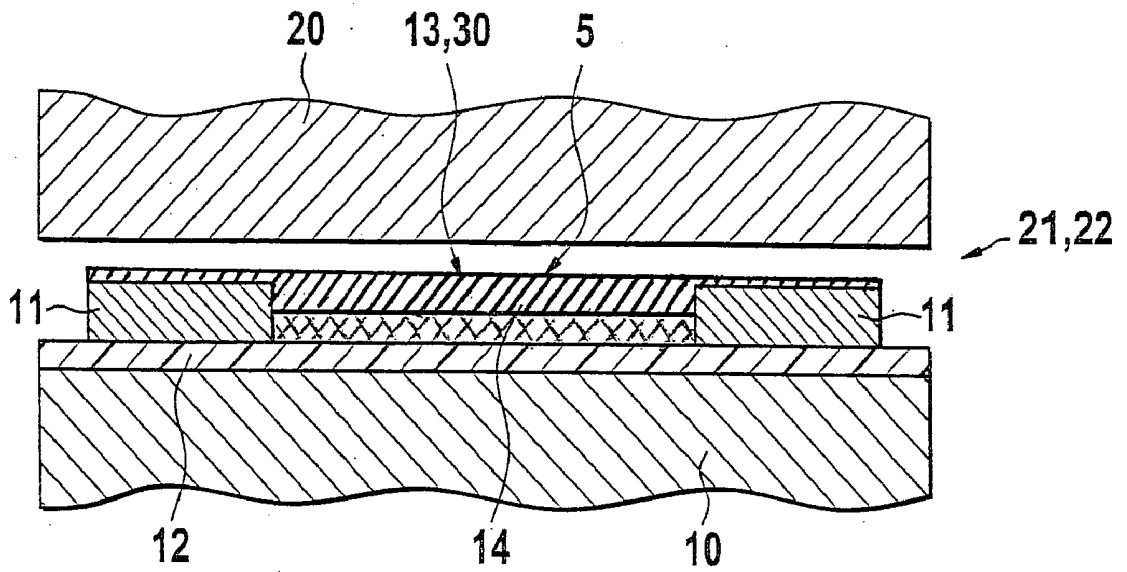
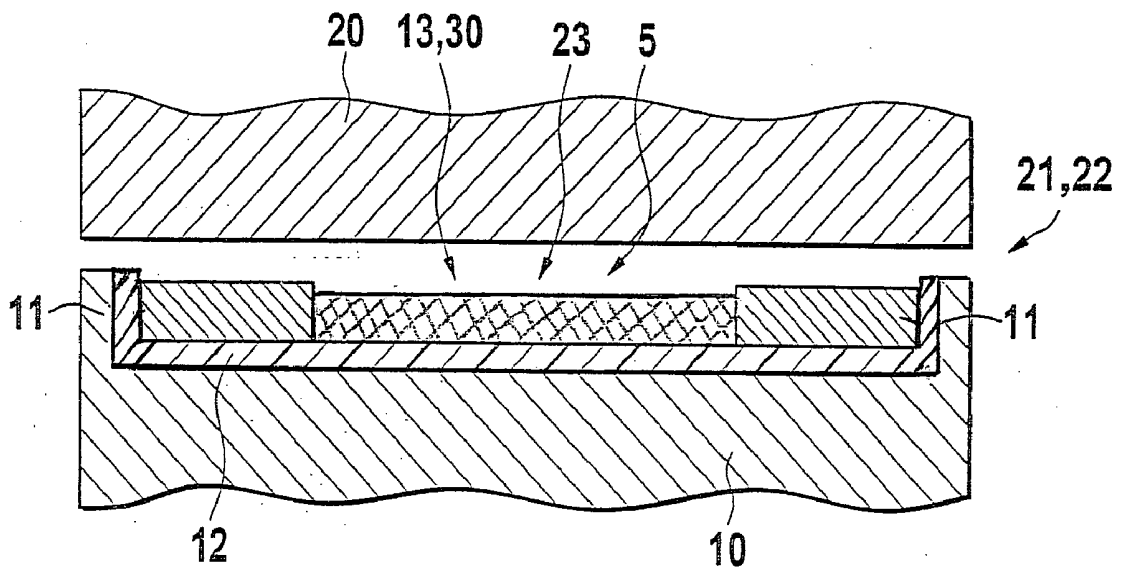

Fig. 3



**SENSOR ELEMENT FOR DETECTING A
PHYSICAL MEASURING VARIABLE BETWEEN
BODIES EXPOSED TO HIGH TRIBOLOGICAL
STRAIN**

[0001] The invention relates to a sensor element for detecting a physical measurement variable such as a pressure, a temperature, a gap width, or a capacitance between two bodies that move in relation to each other during operation and experience high tribological stress, as generically defined by the independent claims.

PRIOR ART

[0002] Lubricated contacts or elastohydrodynamic contacts of the kind that occur, for example, in bearings (ball bearings, roller bearings, or slide bearings) or other elements coupled to each other, such as gear contacts, cam-tappet contacts, etc., are subjected to very high tribological stresses. Under such operating conditions, the lubricating film between the bodies that move in relation to each other can become locally insufficient or can be broken, i.e. a so-called "mixed friction" occurs, which causes the load capacity limits of the materials used to be very quickly reached or even exceeded and causes damage to the corresponding components. In this respect, it is important to monitor the contact temperatures, contact pressures, and/or contact stresses in such highly stressed lubricated component contacts during operation in order to at least detect—e.g. by testing damage mechanisms—but ideally to prevent, the occurrence of critical loads, for example as a result of high friction energy densities, which, when exceeded, cause components of an injection system to fail due to adhesion ("seizing" in automotive engineering).

[0003] A sensor element for detecting temperature or pressure between two bodies that move in relation to each other and experience high tribological stress is known from H. Peeken and A. Köhler, *Konstruktion* 32 (June 1980), pp. 241-246 "Modern Metrology by means of Vapor-Deposited Transducers in Slide and Roller Bearings" [*Moderne Messtechnik mittels aufgedampfter Geber in Gleit- und Wälzlagern*]. This sensor element makes use of the fact that in many materials, the electrical resistance depends on both the temperature and the pressure so that after a calibration measurement, the pressure and/or temperature can be determined simply by measuring the resistance.

[0004] In particular, in the above-mentioned publication, suitably positioned and formed metal layers are deposited on the components to be tested, which carry the desired measurement signal. The above publication also includes the provision that the actual sensor segment and the contact surfaces or strip conductors connected to it are electrically insulated from the component underneath them, which is normally metallic, by means of an intermediary layer, in particular a glass layer or ceramic layer such as a silicon oxide layer or an aluminum oxide layer.

[0005] The object of the current invention was to produce a sensor element for detecting a physical measurement variable such as the pressure or temperature, between two bodies that move in relation to each other during operation and experience high tribological stress, where the actual sensor segment or in general, the actual sensitive layer, is separated from the body underneath it by an insulation layer, which is not only able to withstand very high tribological

stresses, in particular with regard to abrasion resistance and in the event of critical operating states such as mixed friction, but is also designed in such a way that in particular, the sensitive layer in the vicinity of the contact point produces as little as possible influence on or distortion of the physical measurement variable to be detected and the friction conditions present there.

ADVANTAGES OF THE INVENTION

[0006] A first embodiment of the sensor element according to the invention, with a covering layer over the sensitive layer, which is preferably embodied as a sensor segment—a sensor segment also being understood to mean a meander-shaped, structured segment—has the advantage over the prior art that the abrasion resistance and the mechanical loading capacity of the sensor element are significantly improved so that it has an appreciably longer service life, particularly in the event of mixed friction. Moreover, since the covering layer is only very thin, it hardly exerts any influence at all on the detection of the physical measurement variable or the friction conditions present in the contact region.

[0007] In a second embodiment of the sensor element according to the invention, the particularly small design of the actual sensitive layer in comparison to the prior art results in the fact that in the region of the contact point, this sensitive layer has only a negligible influence on the physical measurement variable to be detected and at the same time, assures a very high lateral resolution. It is particularly advantageous if the sensitive layer is embodied as a sensor segment with a length of 10 μm to 5 mm, in particular from 100 μm to 2 mm, a width of less than 5 μm , in particular less than 2 μm , and a thickness of less than 200 nm, in particular less than 10 nm.

[0008] At the same time, a sensitive layer that is thus reduced in size is subjected to a considerably reduced mechanical load and fewer separations occur, particularly when there are temperature changes.

[0009] In a third embodiment of the sensor element according to the invention, finally the actual sensitive layer, primarily in critical operating states, is protected from a rapid wear or its tribological stress is reduced during operation in that it is placed on the insulation layer inside a recess, which is produced in or integrated into the structure of the insulation layer or a surface region of the corresponding body or substrate.

[0010] In addition, the above-mentioned steps for improving the tribological durability with a simultaneously reduced disruption or distortion of physical measurement variables or friction conditions to be detected can also be advantageously combined with one another.

[0011] In the context of the current specification, a layer that is or can be placed under high tribological stress is generally understood to be a layer that is subjected to contact pressures of at least 1 MPa, in particular 10 MPa to 20 GPa, and can withstand them, particularly over the long term, whereas an insulation layer is understood to be a layer whose electrical conductivity does not necessarily have to be zero, but is significantly lower than the electrical conductivity of the sensitive layer and is preferably so low as to be negligible.

[0012] Advantageous modifications of the invention ensue from the steps taken in the dependent claims.

[0013] It is advantageous if the sensitive layer is provided as a sensor segment with a covering layer that is comparatively more abrasion resistant and is either insulating or has a low electrical conductivity, preferably with a thickness of less than 500 nm, in particular less than 200 nm. Furthermore, this covering layer is advantageously a layer made of carbon, in particular a diamond-like carbon or an amorphous diamond-like carbon, which in addition to carbon, can also contain oxygen and silicon in order to reduce the electrical conductivity. It is also advantageous if the covering layer has a structure similar to that of the insulation layer or that of a component layer of the insulation layer, so that it can be deposited using a correspondingly similar manufacturing process.

[0014] It is also advantageous if the insulation layer has at least two component layers, namely a component layer with a high capacity for tribological stress, which has a comparatively high degree of hardness, i.e. a hardness of at least 1000 HV, preferably more than 3000 HV, and a comparatively low coefficient friction, and another component layer, which has a considerably reduced electrical conductivity in comparison to the component layer with the high capacity for tribological stress. This allows the functions of “electrical insulation” and “tribological stress capacity” that the insulation layer should fulfill simultaneously to be divided up between these two component layers.

[0015] It is also advantageous if the high tribological stress capacity component layer of the insulation layer is at least essentially comprised of carbon, in particular a diamond-like carbon or an amorphous diamond-like carbon, and if the component layer with the comparatively low electrical conductivity, in addition to carbon, which is preferably the main ingredient—preferably in the form of a diamond-like carbon or an amorphous diamond-like carbon, also contains oxygen and silicon, preferably as secondary ingredients, which results in a reduction of the electrical conductivity of the amorphous diamond-like carbon, which otherwise has a relatively high electrical conductivity.

[0016] In particular with regard to improving the adhesion and the tribological durability, it has turned out to be advantageous if the insulation layer has a number of recurring pairs of component layers stacked one on top of the other, wherein underneath the sensor segment or sensitive layer, first comes the layer with the higher tribological stress capacity and only under that, comes the component layer that is insulating or has a low electrical conductivity in comparison to the sensitive layer.

[0017] Alternatively to the use of an insulation layer comprised of at least component layers, however, in some applications, it is advantageously also sufficient if the insulation layer does not have a number of component layers of different compositions, but is at least essentially comprised of carbon or in addition to carbon, contains oxygen and silicon in particular. In this instance, the requirements “high tribological stress capacity” and “electrically insulating” are fulfilled by this one layer, which can to that end have either a homogeneous composition or a graduated composition perpendicular to the layer plane, which produces a fluid transition to an insulation layer with a number of component layers.

[0018] Overall, the above-explained composition and structure of the insulation layer leads to a very favorable adhesion to the body that is provided with it, even under extremely high mechanical stresses, so that the insulation layer does not come off even when there are temperature changes and temporary temperature increases. In addition, it is considerably less brittle than insulation layers from the prior art and less prone to wear.

[0019] Only a few specially selected metals such as chromium, platinum, titanium, a nickel-chromium alloy, or a nickel-copper-manganese alloy are suitable as materials for the actual sensitive layer. In addition, the sensitive layer, which is preferably embodied as a sensor segment, has an electrical resistance of 500Ω to 3 kΩ, which is preferable with regard to the most reliable possible, simple signal evaluation and the greatest possible measurement signal with low noise.

[0020] In order to permit the most precise possible detection of the desired physical measurement variable, the upper edge of the sensitive layer or of the sensitive layer provided with the covering layer should be as flush as possible with the surface of the body that is provided with a recess in this region, or this upper edge should protrude above or be recessed below the surface of this body by maximally 500 nm, in particular 200 nm. It is particularly advantageous if the height by which the sensitive layer protrudes beyond or is recessed from the surface of the body is less than its surface roughness.

DRAWINGS

[0021] The invention will be explained in detail in conjunction with the drawings and in the description that follows.

[0022] FIG. 1 shows a top view of a body with a sensor element attached to it,

[0023] FIG. 2 shows a section through FIG. 1 along the cutting line depicted in it, where a second body is also shown, which is spaced apart from the first body and moves in relation to it,

[0024] FIG. 3 shows an alternative embodiment to the one in FIG. 2, likewise depicted as a section through FIG. 1 along the cutting line depicted in it, and

[0025] FIG. 4 gives a detailed sectional view of the layer structure of the sensor element on the body according to FIG. 2 or also FIG. 3, with an additional covering layer.

EXEMPLARY EMBODIMENTS

[0026] FIG. 1 shows a metallic substrate 10, for example a metallic ignition distributor shaft in a high-pressure injection system of a motor vehicle or another technical surface with a roughness that can be up to several μm, certain areas of which have an insulation layer 12 deposited on them, with two contact surfaces 11, which are connected to each other by means of a sensitive layer 30 embodied as a sensor segment 13 so that the contact surfaces 11 and the sensor segment 13 constitute a double-T structure that is connected, together with strip conductors that are not shown, as a sensor element 5 to external electronic components as part of an electronic measurement bridge. In addition, the influence of a physical measurement variable to be detected, in particular

a changing pressure, a changing mechanical stress, or a changing temperature, causes the sensor segment **13** to change in at least one measurable physical property, in particular its electrical resistance. In addition to the temperature and/or pressure in the contact region between the contact surfaces **11**, it is therefore possible, for example by means of the capacitance, to also detect the width of a gap **21** between the contact surfaces **11**, particularly as a function of time, wherein the medium or lubricant between the contact surfaces **11** constitutes the dielectric of a capacitor and the contact surfaces **11** constitute or are correspondingly connected to the plates of the capacitor.

[0027] In addition to the substrate **10**, **FIG. 2** shows a metallic opposing body **20** that is disposed opposite the substrate, for example a bushing of an ignition distributor shaft. The substrate **10** and the opposing body **20** are also separated from each other by a gap **21**, which contains a lubricant **22**, for example oil or a fuel. In addition, **FIG. 2** shows that for example in order to detect a contact pressure and/or a contact temperature, the sensor element **5** is disposed between the bodies **10**, **20** that move in relation to each other and experience high tribological stress. It is clear from this that the contact surfaces **11** and the sensor segment **13** are disposed on the insulation layer **12** and that the sensor segment **13** is provided with an additional covering layer **14**, i.e. the sensor segment **13** disposed on the insulation layer **12** is comprised of the covering layer **14** and the layer **30** that is sensitive with regard to the physical measurement variable to be detected.

[0028] In the example explained, the covering layer **14** is an abrasion resistant, covering layer that is insulating or has a low electrical conductivity, with a thickness of less than 500 nm, which contains an amorphous diamond-like carbon, preferably as a main ingredient, and contains oxygen and silicon, preferably as secondary ingredients. Alternatively, the covering layer **14** can also be essentially comprised only of carbon, in particular an amorphous diamond-like carbon, since this still provides it with a considerably low electrical conductivity in comparison to the sensitive layer **30**.

[0029] In the example explained, the sensitive layer **30** that constitutes the sensor segment **13** is comprised of chromium, titanium, platinum, a nickel-chromium alloy with 80 wt. % Ni and 20 wt. % Cr, or a nickel-copper-manganese alloy with 86 wt. % Cu, 12 wt. % Mn, and 2 wt. % Ni (manganin), and has an electrical resistance of 500 Ω to 3 k Ω .

[0030] Overall, depending on the concrete application, the sensor segment **13** in the example explained has a length of 10 μ m to 5 mm, a width of less than 5 μ m, in particular less than 2 μ m, and a thickness of less than 200 nm, preferably less than 10 nm. Finally, it is clear from **FIG. 2** that the thickness of the sensor segment **13** is different from and in particular, is considerably less than that of the contact surfaces **11**.

[0031] The exemplary embodiment according to **FIG. 3** differs from the exemplary embodiment according to **FIG. 2** in that a recess **23** that corresponds to the dimensions of the contact surfaces **11** and of the sensor segment **13** is provided in the region of the surface of the substrate **10**, wherein the sensor segment **13** and the contact surfaces **11** are disposed on the insulation layer **12** that covers the bottom of the recess **23**. The upper edge of the sensor

segment **13** here, which is possibly provided with the optionally covering layer **14**, is as flush as possible with the surface of the body **10**. To accomplish this, the recess **23** was initially etched into the substrate **10** by means of an appropriately designed mask, and then the insulation layer **12** was deposited precisely in the region of the recess **23** so that the recess **23** is then filled again, preferably completely. The size of the recess **23** should be dimensioned so that there is sufficient space on the insulation layer **12** to fully accommodate the contact surfaces **11** and the associated strip conductors as well as the sensor segment **13**. Then another appropriately designed mask was used to etch a second recess into the insulation layer **12** for the contact surfaces **11** and the associated strip conductors. The contact surfaces **11** and the associated strip conductors can then be inserted into this second recess so that it, too, is filled again, preferably completely. Then, if necessary, an appropriately designed mask is used to etch a third recess into the insulation layer **12** for the sensor segment **13**; the sensor segment **13** or the sensitive layer **30** is then deposited into this third recess. If an additional covering layer **14** and/or a bonding layer **33** is subsequently deposited, then this must be appropriately taken into consideration in the etching particularly of the first recess. The covering layer **14** here preferably also extends over the contact surfaces **11** and possibly associated strip conductors, if this region contacts the opposing body **20** during operation. The dimensions of the sensor segment **13** in **FIG. 3** are selected to be analogous to those in **FIG. 2**.

[0032] Alternatively, the upper edge of the sensor segment **13** or the upper edge of the covering layer **14** likewise optionally provided in **FIG. 3** can also protrude beyond or be recessed from the surface of the substrate **10** by maximally 500 nm. Preferably the order of magnitude by which the sensor segment **13** or the covering layer **14** protrudes beyond or is recessed from the surface of the substrate **10** is on the same order of magnitude as the surface roughness of the substrate **10**.

[0033] In another exemplary embodiment that is not shown, the insulation layer **12** can be deposited onto the substrate **10** first and then the recess **23** can be produced in the insulation layer **12**. Then the sensor segment **13**—or in general the sensitive layer **30**—and the contact surfaces **11** as well as the optionally provided covering layer **14** are subsequently deposited or produced in the recess **23** that has been thus produced in the insulation layer **12**. In addition, in a modification of this embodiment, other recesses can be provided in or structurally integrated into the insulation layer **12**, wherein the contact surfaces **11** are then disposed on the insulation layer **12** in the region of or inside these additional recesses and are simultaneously electrically connected to the sensitive layer **30**. This embodiment permits a particularly simple and reliable contacting of the sensitive layer **30**, wherein the contact surfaces **11** are also protected from wear and are simultaneously insulated in relation to the substrate **10**.

[0034] In view of the fact that the influence of the sensor element **5** on the measurement result in the detection of the physical measurement variable should be as low as possible, according to **FIGS. 2 and 3**, the area of the sensor element **5** viewed from above and the area of the insulation layer **12** are always kept as small as possible and primarily as thin as possible so that to the greatest extent possible, the lubricated contact takes place only between the primary surfaces. This

aim is also served by the embedding of the sensor element **5** into the surface of the substrate **10** to be tested and by the requirement that the surface of the sensor segment **13** or the covering layer **14** be situated as close as possible to the same height as the upper edge of the substrate **10**. Finally, the thin embodiment of the covering layer **14** also results in a reduced distortion of the measurement signal of the sensor element **5**.

[0035] FIG. 4 gives a detailed depiction of the design of the insulation layer **12** on the substrate **10**, in which a bonding layer **33** is also provided between the substrate **10** and the insulation layer **12**, and in addition to the sensitive layer **30**, the optional covering layer **14** according to FIG. 2 or **3** is also provided on the insulation layer **12**. The specific electrical resistance of the insulation layer **12** as a whole is approx. $3 \cdot 10^7 \Omega\text{m}$.

[0036] The bonding layer **33** according to FIG. 4 has a thickness of 20 nm to $1 \mu\text{m}$ and can in addition optionally also be provided between the sensor segment **13**, i.e. the sensitive layer **30**, and the covering layer **14**, with a thickness of 20 nm to $1 \mu\text{m}$. An additional bonding layer between the sensitive layer **30** and the covering layer **14** was not required in the exemplary embodiment explained above.

[0037] The bonding layer **33** is preferably comprised of carbon, in particular a diamond-like carbon or an amorphous diamond-like carbon, and silicon or contains these elements as essential ingredients. Alternatively, it can also be comprised of a metal such as chromium or titanium, a metal alloy, or a semiconductor such as silicon, or the bonding layer **33** has a number of component layers of different compositions stacked one on top of the other. One of these component layers, for example, is a layer that is comprised of carbon, in particular a diamond-like carbon or an amorphous diamond-like carbon, and silicon or that contains these elements as essential ingredients, and another of these component layers, for example, is a layer that is comprised of a metal such as chromium or titanium or a metal alloy. However, other material combinations, even the other materials mentioned above for the bonding layer **33**, can also be used in the component layers.

[0038] The insulation layer **12** according to FIG. 4 is comprised of a total of six component layers, which can be integrated into three component layer pairs. In the example explained, each of these six component layers has a thickness of approx. 660 nm. The component layers that make up the insulation layer **12** are divided up into component layers **31** with at least a low electrical conductivity in comparison to the sensor segment **13** and component layers **32** with a higher tribological stress capacity than the component layers **31** with the comparatively low electrical conductivity, wherein the component layers **32** with the higher tribological stress capacity simultaneously have a higher electrical conductivity than the component layers **31** with the comparatively low electrical conductivity or have a favorable electrical conductivity in comparison to them. In particular, the component layer **32** with the higher tribological stress capacity has the highest degree of hardness possible in comparison to the layer **31** with the comparatively low electrical conductivity, preferably a hardness of greater than 1000 HV, particularly preferably greater than 3000 HV, and as low a coefficient of friction as possible, preferably a coefficient of friction of less than 0.01.

[0039] The layer **32** with the higher tribological stress capacity is preferably at least essentially comprised of carbon, in particular an amorphous diamond-like carbon. The layer **31** with the comparatively low electrical conductivity is preferably comprised of carbon, in particular an amorphous diamond-like carbon, and in addition, also contains oxygen and silicon, primarily in order to reduce its electrical conductivity.

[0040] In addition, it is important that directly under the sensor segment **13** or the sensitive layer **30**, first comes a layer with a high tribological stress capacity, i.e. the component layer **32**, and then under that comes a component layer with at least a low electrical conductivity in comparison to the sensor segment **13**, i.e. the component layer **31**. These two component layers **31**, **32** constitute a component layer pair, which recurs several times, as depicted in FIG. 4.

[0041] In general, the component layer **32** with the higher tribological stress capacity and the component layer **31** with the comparatively low electrical conductivity each have a layer thickness of 50 nm to $5 \mu\text{m}$, in particular of 300 nm to $1 \mu\text{m}$.

[0042] Numerous manufacturing processes are known from the prior art for producing amorphous diamond-like carbon layers, of the kind required to produce the insulation layer **12**, the covering layer **14**, and the bonding layer **33** in the examples explained above. For example, an overview of the properties of amorphous, diamond-like carbon layers can be found in the following articles: J. Robertson, "Hard Amorphous (Diamond-Like) Carbon", *Progress in Solid State Chemistry*, 21, 4 (1991), pp. 199 to 333 or U. Müller, R. Hauert, and M. Tobler "Ultraschall-Beschichtungen aus Kohlenstoff" [Ultraschall Material Layers Made of Carbon], *Oberflächen und Werkstoffe* [Surfaces and Materials], 38, (1997), pp. 8 to 15.

[0043] Amorphous diamond-like carbon layers deposited primarily using PACVD ("plasma-activated chemical vapor deposition") have become established for the function of abrasion resistant protective layers. In this method, a plasma is produced in a deposition chamber at a low gas pressure of less than 10 kPa through the application of a sufficiently high voltage (d.c. voltage or a.c. voltage of a few Hertz to several GHz), for example a high-frequency voltage of 13.56 MHz, and a reactive gas is supplied to this plasma, for example acetylene or another hydrocarbon gas that is gaseous under normal circumstances, such as an alkane (methane, ethane, propane, butane, . . .), alkene, (ethene, propene, butene, . . .), or alkyne, or also a compound that is liquid under normal conditions, such as benzene, cyclohexane, or toluene. Acetylene is preferable since this gas has the highest carbon to hydrogen ratio and produces the densest and hardest layers.

[0044] As a rule, the amorphous diamond-like carbon layers produced in this manner, which are also better known as hydrocarbon layers, have a not very high specific electrical resistance on the order of magnitude of $10^4 \Omega\text{m}$. With a typical layer thickness of approx. $1 \mu\text{m}$ and a contact area of approx. 0.5 cm^2 , this produces a short circuit resistance of approx. 200Ω . This value should be compared with the desired electrical resistance of the sensor segment **13**, which is on the order of magnitude of 1 k Ω . In order to produce a sufficient electrical insulation of the sensor segment **13** in relation to the insulation layer **12**, however, it is desirable for

the insulation layer **12** to have a specific electrical resistance that is at least three orders of magnitude greater, i.e. preferably of approx. $10^7 \Omega\text{m}$.

[0045] This increase in the specific electrical resistance of the insulation layer **12** is achieved through the composition of the insulation layer **12** and/or through the previously explained division into component layers **31**, **32**, wherein the mechanical properties of a pure amorphous diamond-like carbon layer are largely retained for the insulation layer **12** as a whole.

[0046] The desired increase in the specific electrical resistance of an amorphous diamond-like carbon layer for producing the component layer **31** with the at least low electrical conductivity can be achieved in the simplest manner by changing the deposition parameters during the manufacturing process, in particular by admixing a reactive gas such as an organosilanol during the layer deposition. In this case, use is made of the fact that the integration of silicon-oxygen compounds, for example, into the amorphous diamond-like carbon layer reduces its electrical conductivity. This method, however, is limited in that the integration of these additional compounds or elements does in fact increase the specific electrical resistance, but also simultaneously involves an unacceptable degradation of the tribological properties of the layer that is produced. Thus the addition of hexamethyldisiloxane causes amorphous diamond-like carbon layers to become glass-like so that a very brittle layer is produced, which is no longer able to withstand high mechanical stresses.

[0047] The provided division of the insulation layer **12** into two component layers **31**, **32** that have different functions succeeds on the whole very well and simply at fulfilling the requirements of the insulation layer **12** with regard to both electrical conductivity and mechanical durability. In particular, the above-described sequence of the component layer **31**, which has at least a low electrical conductivity, and the component layer **32**, which has a higher tribological stress capacity and is more electrically conductive, as a whole produces an insulation layer **12** that has a high mechanical load capacity, a sufficient ductility and adhesion, and that as a whole, is electrically insulating.

[0048] Based on these preliminary considerations, the bonding layer **33** is preferably produced by depositing a metal or a combination of different metals by means of PVD ("physical vapor deposition"), CVD ("chemical vapor deposition"), or PACVD ("plasma-activated chemical vapor deposition") using a metalliferous gas, for example a metal chloride or an organometal, as a reactive gas. In addition, tetramethylsilane or one of the previously mentioned hydrocarbon gases can also be used as the reactive gas for the deposition of the bonding layer **33**.

[0049] The component layer **31** with at least a low electrical conductivity is deposited with the aid of the PACVD method explained above, using a mixture of one or more gases from the group including oxygen, silane, in particular monosilane, organosilane, in particular tetramethylsilane, organosilanol, in particular hexamethyldisiloxane, and hydrocarbon gas as the reactive gas. Preferably, a mixture of hexamethyldisiloxane and acetylene is used as the reactive gas, which is particularly preferably comprised of 75 vol. % hexamethyldisiloxane and 25 vol. % acetylene. Alternatively, however, it is also possible to use hexamethyldi-

loxane exclusively. In order to deposit the component layer **32** with the higher tribological stress capacity, which simultaneously has a better electrical conductivity, preferably acetylene is used as the reactive gas in the PACVD method explained above.

[0050] Finally, the layer sequence of the component layers **31**, **32** comprising the insulation layer **12** is preferably produced using the PACVD method explained above to produce the entire coating in one pass, i.e. without interrupting the plasma, wherein at the transition from one component layer to the other, a change in the reactive gas takes place either abruptly, progressively, i.e. in a few small steps, or continuously or quasi-continuously, i.e. in a large number of small steps. Apart from that, the layer thickness of the insulation layer **12** as a whole should be no more than $6 \mu\text{m}$.

[0051] It should incidentally also be mentioned that the substrate **10** and/or the opposing body **20** are comprised, for example, of hardened steel (DIN material number 1.4125 or 1.3505).

1. A sensor element for detecting a physical measurement variable such as a pressure, a temperature, a capacitance, or a gap width between two bodies (**10**, **20**) that move in relation to each other during operation and experience high tribological stress, wherein in certain areas between the surfaces of the bodies (**10**, **20**) that move in relation to each other, in a surface region of at least one of the bodies (**10**), a sensitive layer (**13**, **30**) is provided, which is separated from the body (**10**) by an insulation layer (**12**), characterized in that the sensitive layer (**13**, **30**) is provided with a covering layer (**14**).

2. The sensor element according to claim 1, characterized in that in comparison to the sensitive layer (**13**, **30**), the covering layer (**14**) is abrasion resistant and has a low electrical conductivity or is insulating.

3. The sensor element according to claim 1 or 2, characterized in that the covering layer (**14**) has a thickness of less than 500 nm, in particular less than 200 nm.

4. The sensor element according to one of the preceding claims, characterized in that the covering layer (**14**) contains or is at least essentially comprised of carbon, in particular a diamond-like carbon or an amorphous diamond-like carbon, or that it contains carbon, in particular a diamond-like carbon or an amorphous diamond-like carbon as well as oxygen and silicon.

5. The sensor element according to one of the preceding claims, characterized in that the sensitive layer (**13**, **30**), which is particularly embodied in the form of a sensor segment (**13**), is comprised of a metal, in particular chromium, platinum, titanium, or a nickel-chromium or nickel-copper-manganese alloy and has an electrical resistance of 500Ω to $3 \text{ k}\Omega$.

6. The sensor element according to one of the preceding claims, characterized in that the sensitive layer (**13**, **30**) is connected to external electronic components as part of an electronic measurement bridge by means of contact surfaces (**11**), which are provided at two ends and are separated from the body (**10**) by means of the insulation layer (**12**), and possibly by means of additional strip conductors.

7. The sensor element according to one of the preceding claims, characterized in that the sensitive layer (**13**, **30**) has a different thickness, in particular a significantly smaller thickness than the contact surfaces (**11**).

8. The sensor element according to one of the preceding claims, characterized in that the sensitive layer (13, 30), which is in particular embodied as a sensor segment (13), has a length of 10 μm to 5 mm, a width of 50 nm to 50 μm , in particular of 50 nm to 5 μm , and a thickness of less than 200 nm, in particular less than 10 nm.

9. The sensor element according to one of the preceding claims, characterized in that a bonding layer (33) is provided between the insulation layer (12) and the body (10) and/or between the sensitive layer (13, 30) and the covering layer (14).

10. The sensor element according to one of the preceding claims, characterized in that the bonding layer (33) between the insulation layer (12) and the body (10) has a thickness of 20 nm to 1 μm and/or the bonding layer (33) between the sensitive layer (13, 30) and the covering layer (14) has a thickness of 20 nm to 1 μm .

11. The sensor element according to one of the preceding claims, characterized in that the bonding layer (33) contains carbon, in particular a diamond-like carbon or an amorphous diamond-like carbon, and silicon, that the bonding layer (33) is comprised of a metal such as titanium or chromium, an alloy, or a semiconductor such as silicon, or that the bonding layer (33) has at least two component layers of different composition disposed one on top of the other.

12. The sensor element according to one of the preceding claims, characterized in that the insulation layer (12) has at least two component layers (31, 32), wherein one component layer (31) is a layer (31) with at least a low electrical conductivity in comparison to the sensitive layer (13, 30) and wherein a component layer (32) is a layer with a higher tribological stress capacity in comparison to the component layer (31) with the comparatively low electrical conductivity, or in that the insulation layer is a layer that is at least essentially comprised of carbon or contains carbon, oxygen, and silicon.

13. The sensor element according to claim 12, characterized in that the component layer with the higher tribological stress capacity is a layer (32) with a comparatively high electrical conductivity in comparison to the component layer (31) with the low electrical conductivity and has a high degree of hardness and/or a low coefficient of friction in comparison to it.

14. The sensor element according to one of the preceding claims, characterized in that the layer (32) with the higher tribological stress capacity is at least essentially comprised of carbon, in particular a diamond-like carbon or an amorphous diamond-like carbon, and that the layer (31) with the comparatively low electrical conductivity is comprised of carbon, in particular a diamond-like carbon or an amorphous diamond-like carbon, as well as oxygen and silicon.

15. The sensor element according to one of the preceding claims, characterized in that the insulation layer (12) has a number of recurring pairs of component layers stacked one on top of the other, wherein immediately underneath the sensitive layer (13, 30), first comes the layer (32) with the higher tribological stress capacity and underneath that, comes the layer (32) with at least a low electrical conductivity in comparison to the sensitive layer (13, 30), and wherein these two layers (31, 32) constitute the component layer pair.

16. The sensor element according to one of the preceding claims, characterized in that the influence of the physical measurement variable, in particular a changing pressure

and/or a changing temperature, causes the sensitive layer (13, 30) to change in at least one measurable physical property, in particular its electrical resistance.

17. The sensor element according to one of the preceding claims, characterized in that the two bodies (10, 20) that move in relation to each other are separated from each other by a gap (21) that contains a lubricant (22).

18. A sensor element for detecting a physical measurement variable such as a pressure, a temperature, a gap width, or a capacitance between two bodies (10, 20) that move in relation to each other during operation and experience high tribological stress, particularly according to one of the preceding claims, wherein in certain areas between the surfaces of the bodies (10, 20) that move in relation to each other, in a surface region of at least one of the bodies (10), a sensitive layer (13, 30) is provided, which is separated from the body (10) by an insulation layer (12), characterized in that the sensitive layer (13, 30) has a length of 10 μm to 5 mm, a width of less than 5 μm , and a thickness of less than 200 nm.

19. A sensor element for detecting a physical measurement variable such as a pressure, a temperature, a gap width, or a capacitance between two bodies (10, 20) that move in relation to each other during operation and experience high tribological stress, particularly according to one of the preceding claims, wherein in certain areas between the surfaces of the bodies (10, 20) that move in relation to each other, in a surface region of at least one of the bodies (10), a sensitive layer (13, 30) is provided, which is separated from the body (10) by an insulation layer (12), characterized in that a surface region of at least one of the two bodies (10) has a recess (23) that contains the sensor surface (13) on the insulation layer (12).

20. The sensor element according to claim 19, characterized in that the upper edge of the sensitive layer (13, 30) or of the sensitive layer (13, 30) provided with a covering layer (14) is at least approximately flush with the surface of the body (10), protrudes above this surface by maximally 500 nm, in particular less than 100 nm, or is recessed below this surface by maximally 500 nm, in particular less than 100 nm.

21. The sensor element according to claim 19, characterized in that contact surfaces (11) are disposed in the recess (23) at two ends of the sensitive layer (13, 30), wherein the contact surfaces (11) and the sensitive layer (13, 30) are separated from the body (10) by means of the insulation layer (12), which is in particular only provided at the bottom of the recess (23).

22. The sensor element according to one of claims 19 to 21, characterized in that the recess (23) is produced in the insulation layer (12), wherein the sensitive layer (13, 30) is disposed in the recess (23), on the insulation layer (12).

23. The sensor element according to one of claims 19 to 22, characterized in that the insulation layer (12) has additional recesses, wherein the contact surfaces (11) are disposed on the insulation layer (12) in the vicinity of or inside the additional recesses, and are connected to the sensitive layer (13, 30).

24. The use of a sensor element according to one of the preceding claims to detect a contact pressure and/or a contact temperature and/or a gap width in the contact region between lubricated components that experience high tribological stress.

专利名称(译)	传感器元件，用于检测暴露于高摩擦应变的物体之间的物理测量变量		
公开(公告)号	US20040006258A1	公开(公告)日	2004-01-08
申请号	US10/415229	申请日	2002-09-06
[标]申请(专利权)人(译)	MEYER KLAUS NEMZOV JULIUS MULLER ULRICH		
申请(专利权)人(译)	MEYER KLAUS NEMZOV JULIUS MUELLER ULRICH		
当前申请(专利权)人(译)	罗伯特·博世有限公司		
[标]发明人	MEYER KLAUS NEMZOV JULIUS MUELLER ULRICH		
发明人	MEYER, KLAUS NEMZOV, JULIUS MUELLER, ULRICH		
IPC分类号	G01L19/06 F16C17/00 F16C19/00 G01L5/00 A61B5/00		
CPC分类号	F16C17/00 G01L5/0085 G01L5/0014 F16C19/00 F16C17/24 F16C19/52		
优先权	10144271 2001-09-08 DE		
其他公开文献	US7523670		
外部链接	Espacenet USPTO		

摘要(译)

本发明提出了用于检测物理测量变量的传感器元件 (5)，例如在操作期间相对于彼此移动并且经历高摩擦学的两个主体 (10,20) 之间的压力，温度，间隙宽度或电容。强调。在主体 (10,20) 的相对于彼此移动的表面之间的某些区域中，在至少一个主体 (10) 的表面区域中，敏感层 (13,30)，特别是传感器提供了段 (13)，其通过绝缘层 (12) 与主体 (10) 分离并且在第一实施例中具有覆盖层 (14)。在替代实施例中，两个主体 (10) 中的至少一个的表面区域具有凹部 (23)，传感器表面 (13) 设置在凹部 (23) 中。在第三实施例中，传感器表面 (13) 的长度为10μm至5mm，宽度小于5μm，并且厚度小于200nm。

