



(19) **United States**

(12) **Patent Application Publication** (10) **Pub. No.: US 2001/0044624 A1**

Seraj et al.

(43) **Pub. Date: Nov. 22, 2001**

(54) **INTRALUMINAL VISUALIZATION SYSTEM WITH DEFLECTABLE MECHANISM**

(52) **U.S. Cl. 606/41; 600/585**

(76) Inventors: **Mahmoud K. Seraj**, Apex, NC (US);
Eric Chan, Newark, CA (US); **James F. Kelley**, Coon Rapids, MN (US)

(57) **ABSTRACT**

Correspondence Address:
Beth L. McMahon
Medtronic, Inc., MS 301
7000 Central Avenue NE
Minneapolis, MN 55432 (US)

This is a combination method and system for intravascularly accessing and visualizing a body structure. A system is disclosed comprising a sheath, a balloon catheter, and a catheter deflection mechanism. A micro-deflection mechanism, which may be placed into the lumen of devices such as cardiac leads or electrophysiology catheters, is also provided for accurate guidance and placement of such devices to their target location. In one embodiment, a procedure for a lead or catheter placement is described in which a combination deflection mechanism, balloon catheter, and sheath assembly access the coronary sinus ostium via a superior approach. A distal balloon on the catheter is inflated and an occlusive venogram is obtained under fluoroscopic guidance to visualize the coronary veins. The sheath is advanced into the coronary sinus ostium and the balloon is deflated. The catheter and deflection mechanism are then removed. Next, a micro-deflection mechanism that has been inserted into the lumen of a cardiac lead is deployed through the sheath, allowing the lead to deflect with a high degree of accuracy and control as it is placed in the selected location.

(21) Appl. No.: **09/822,678**

(22) Filed: **Mar. 30, 2001**

Related U.S. Application Data

(63) Non-provisional of provisional application No. 60/193,695, filed on Mar. 31, 2000.

Publication Classification

(51) **Int. Cl.⁷ A61B 18/14; A61B 5/00; A61M 25/00**

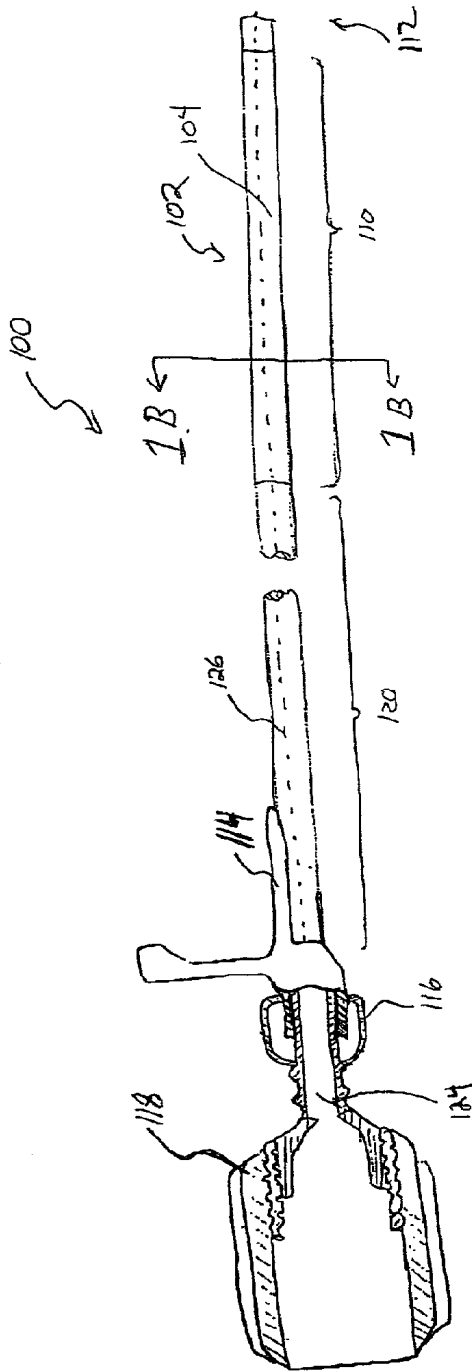

FIG. 1A

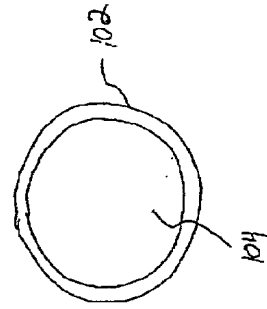

FIG. 1B

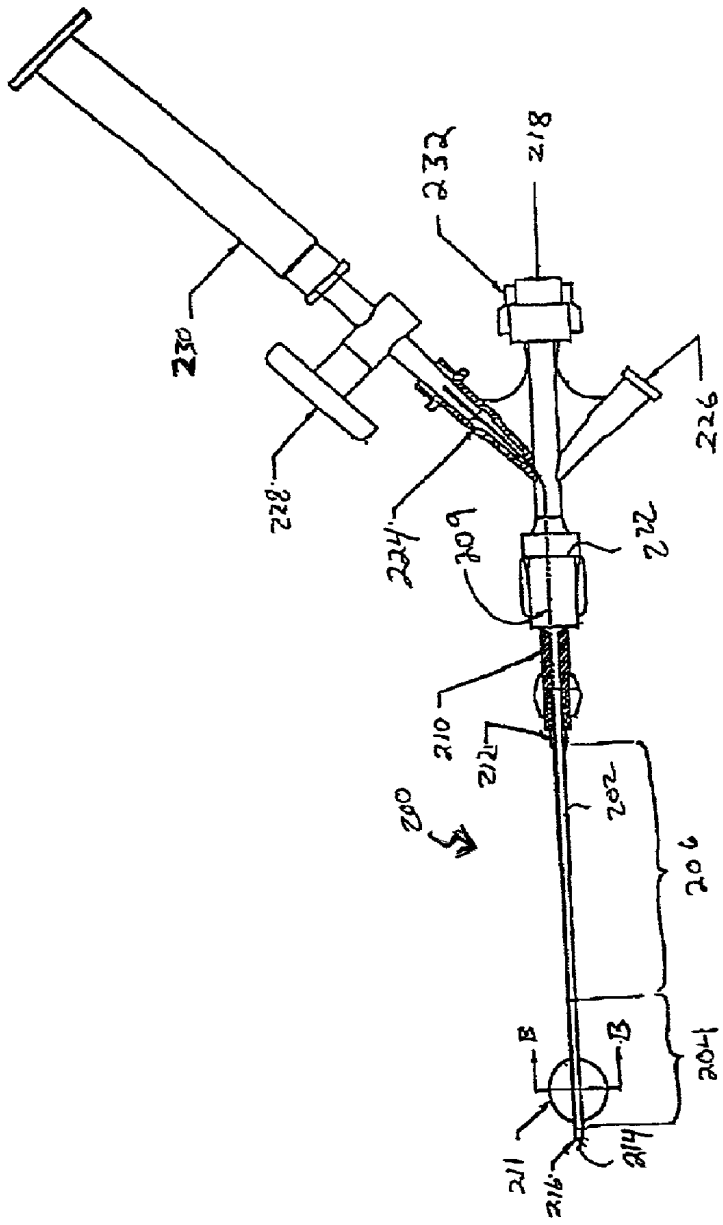

FIG. 2A

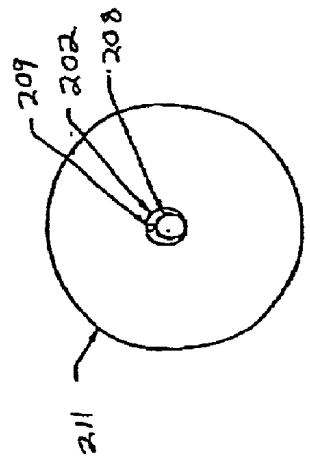

FIG. 2B

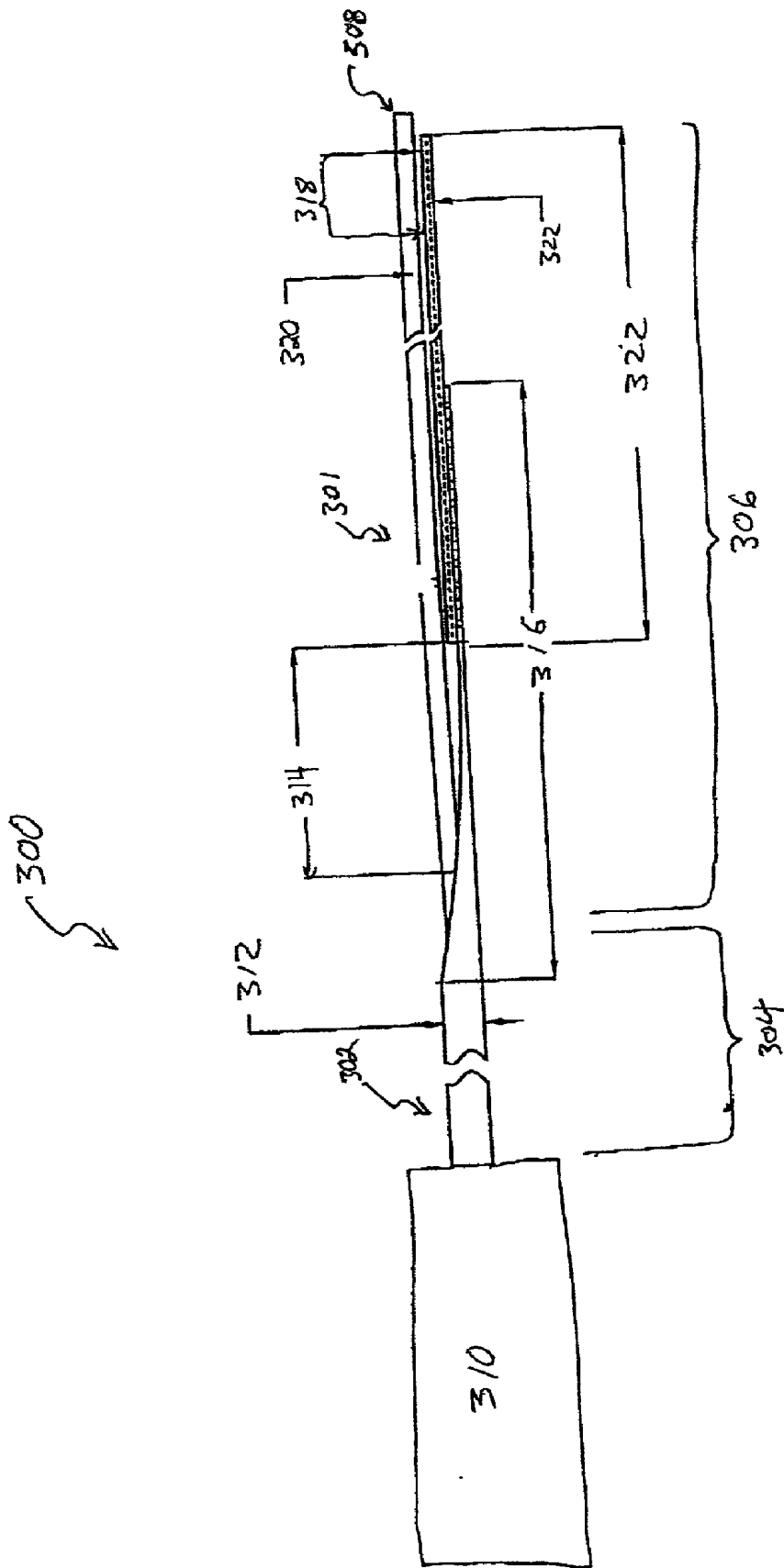

FIG. 3

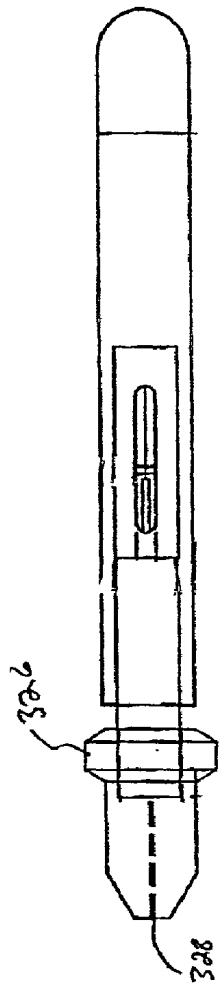

FIG 4B
310

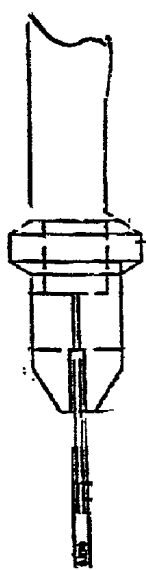

FIG 4A
310

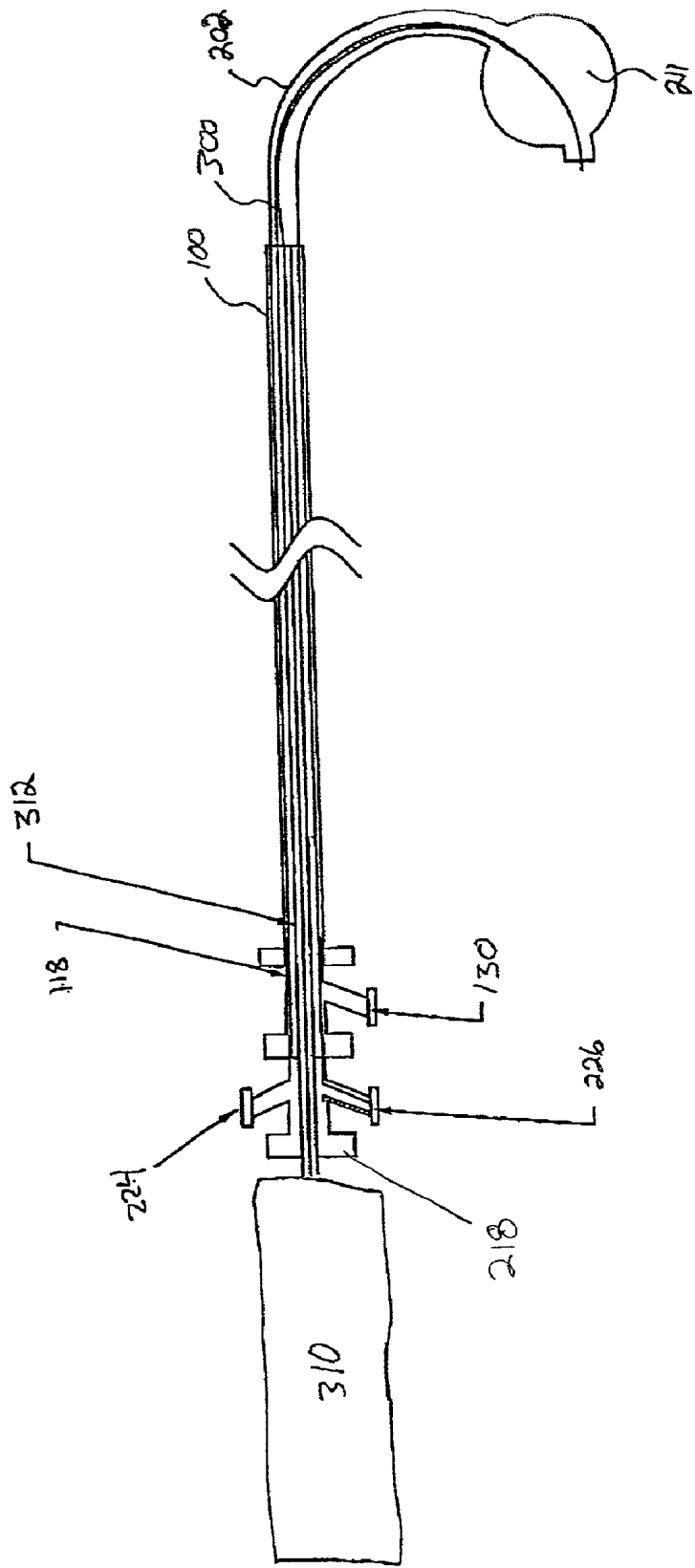

FIG. 5

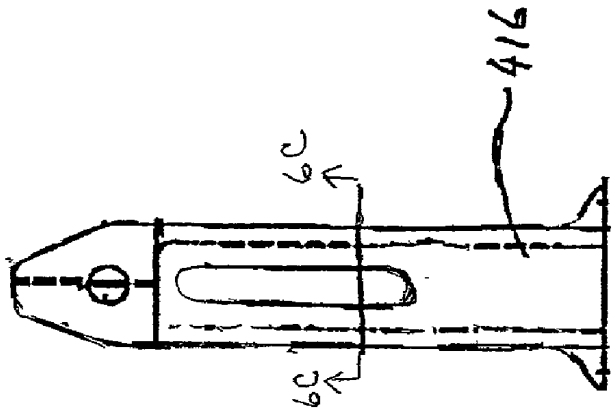

FIG 6D

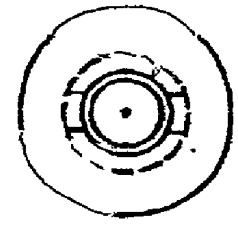

FIG 6C

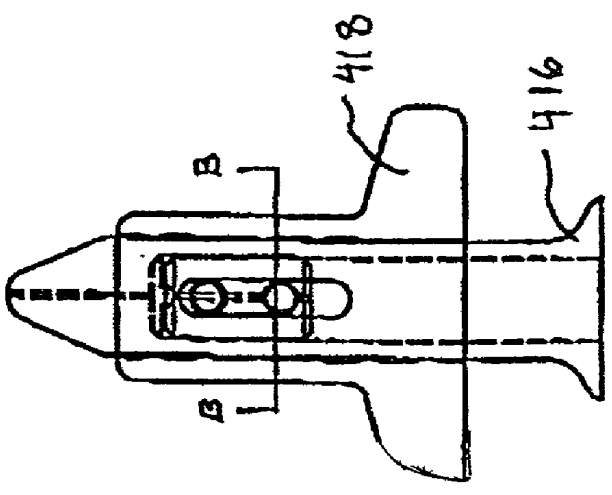

FIG 6A

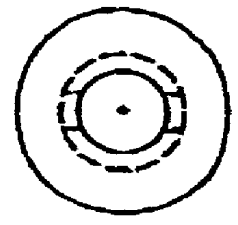

FIG 6B

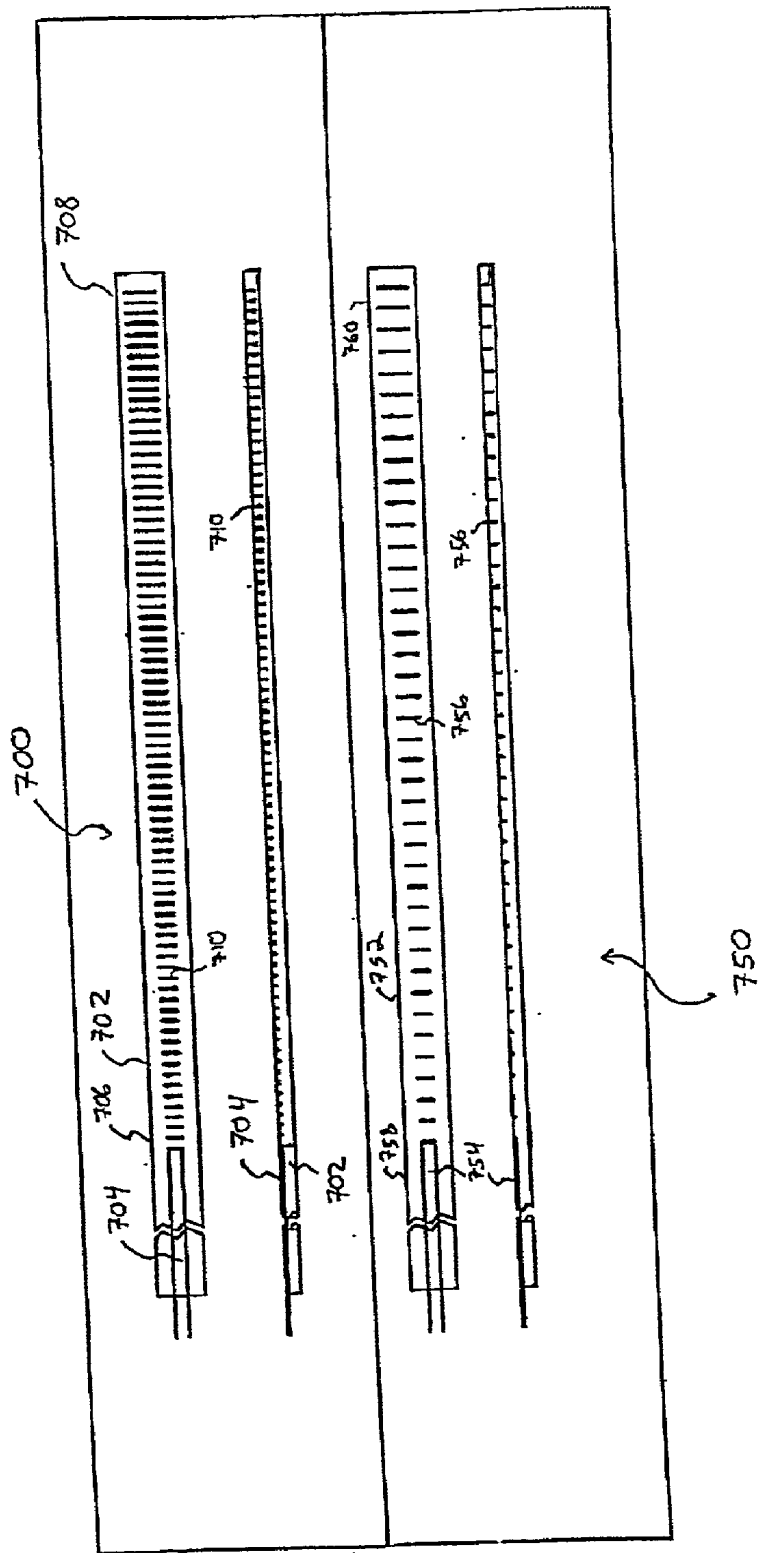

FIG 7A

FIG 7B

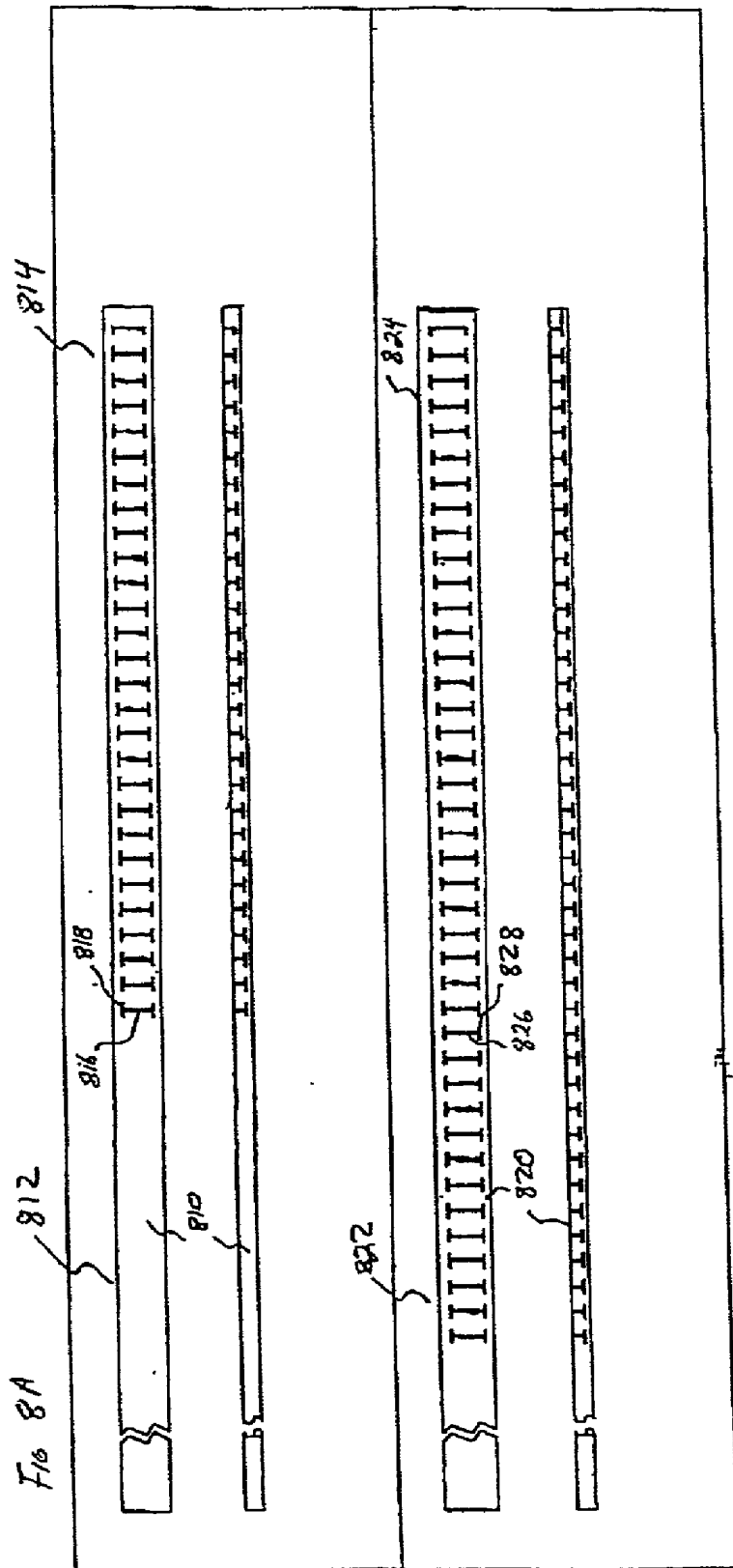

FIG 8A

FIG 8B

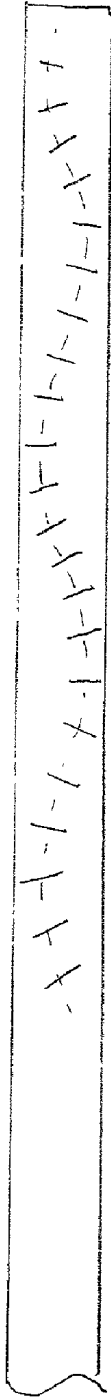

FIG. 8C

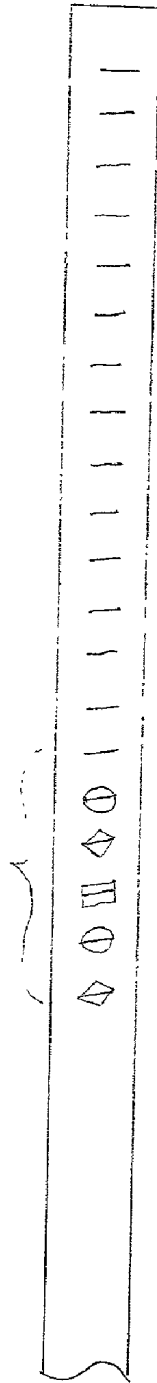

FIG. 8D

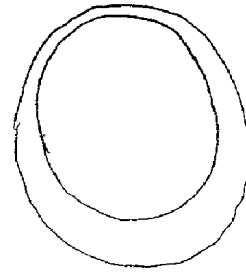

FIG 8E

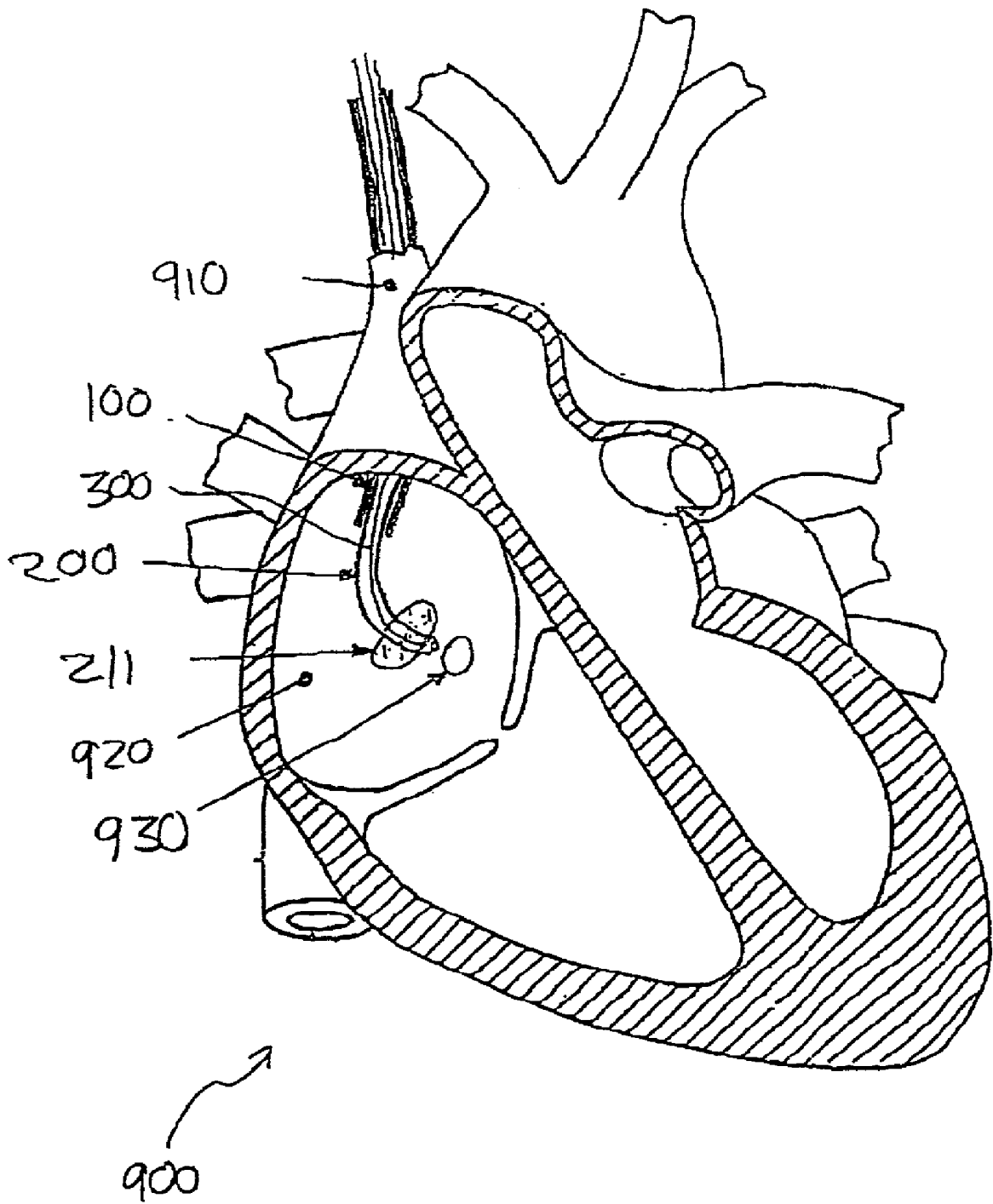

FIG. 9

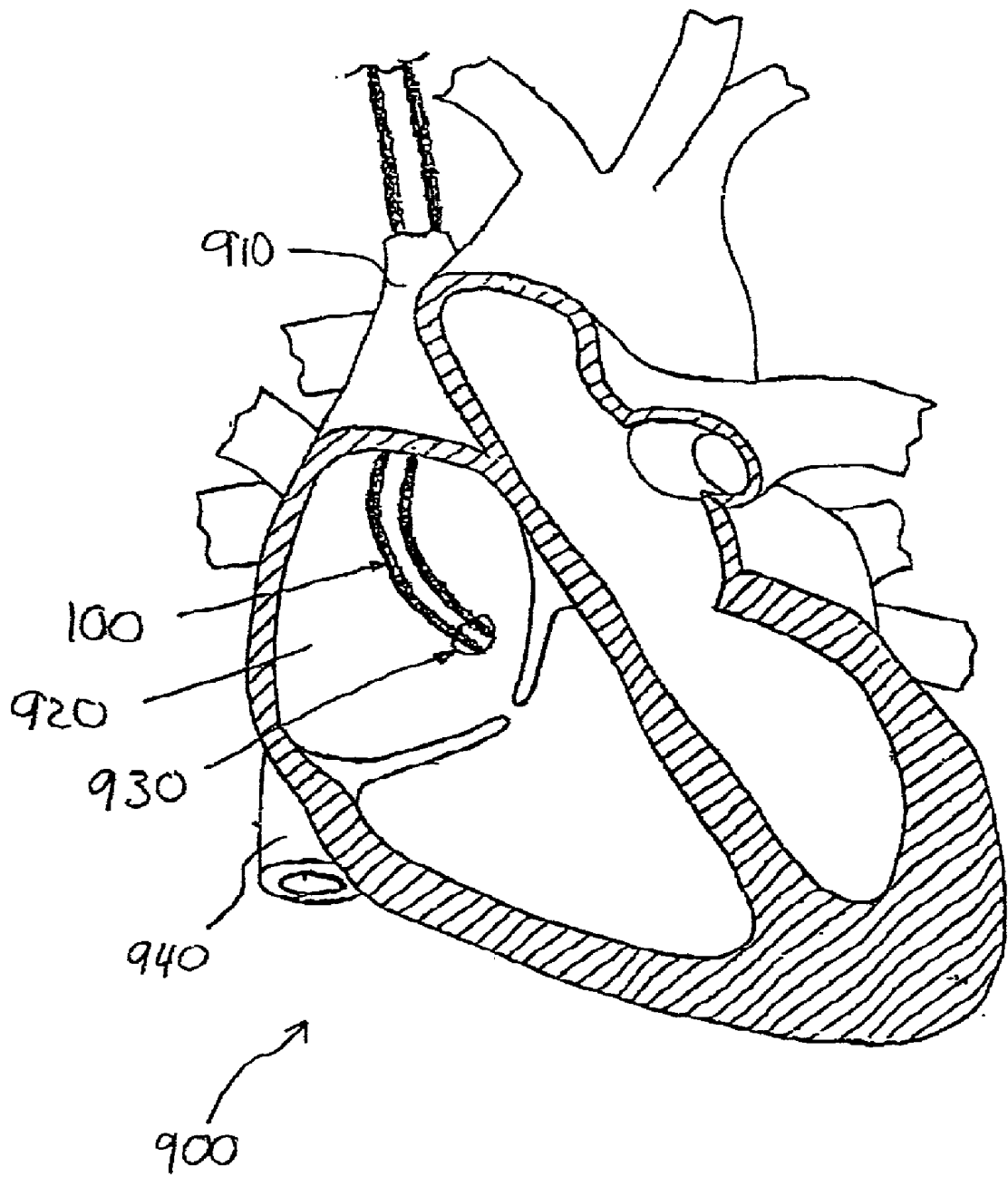

FIG. 10

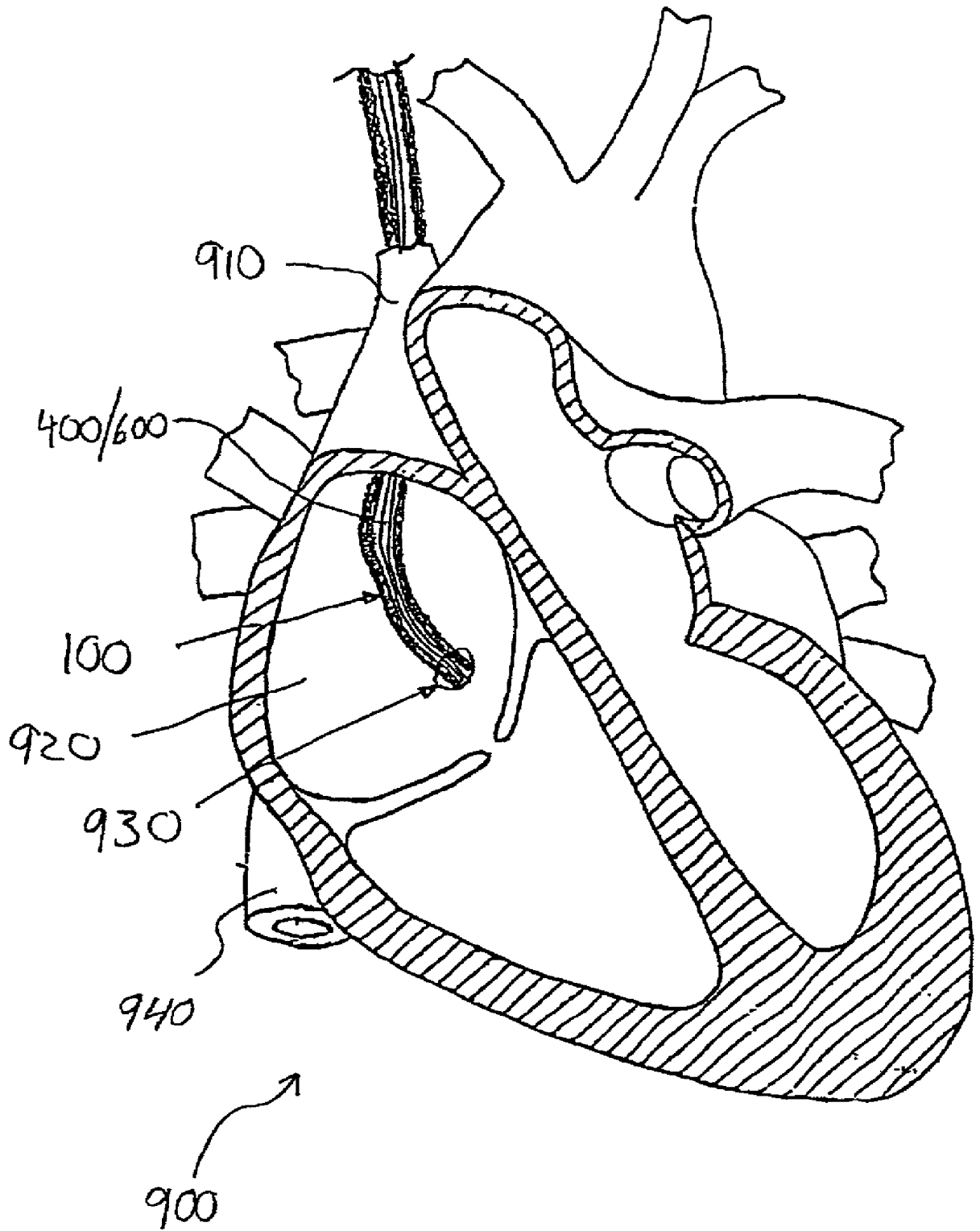
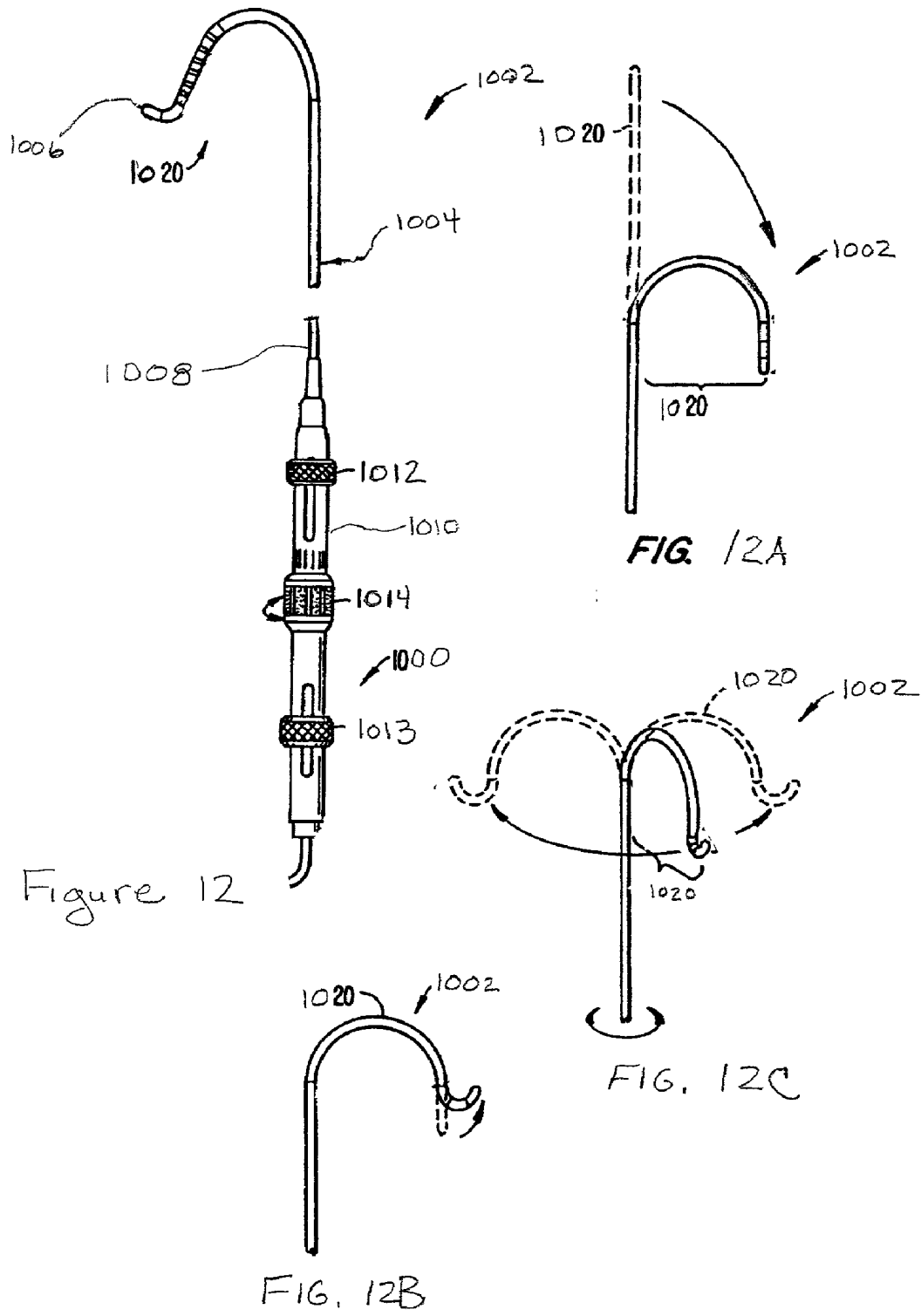

FIG. 11



INTRALUMINAL VISUALIZATION SYSTEM WITH DEFLECTABLE MECHANISM

RELATED APPLICATIONS

[0001] This application is related to, and claims the benefit of, provisionally-filed U.S. patent application Ser. No. 60/193,695 filed Mar.31, 2000, and entitled "Intraluminal Visualization System with Deflectable Mechanism", which is incorporated herein by reference in its entirety.

BACKGROUND OF THE INVENTION

[0002] This invention relates generally to a system and method for mammalian intraluminal visualization and delivery of various devices or agents into a targeted area of the body. More particularly, this invention relates to a visualization and delivery system for accurately placing devices such as leads, electrophysiology catheters, and therapeutic agents into large-organ vessel systems such as the coronary vasculature.

[0003] In treating conditions such as arrhythmia, one technique is to destroy or damage heart tissue that causes or is involved with the arrhythmia by suitably heating the tissue, e.g., by applying a laser beam or high-frequency electrical energy such as radio-frequency (RF) or microwave energy.

[0004] For such treatment to be effective, the location of the tissue site causing or involved with the arrhythmia must be accurately determined in order to be able to contact heart tissue adjacent the desired location with a tissue-destroying device. A high degree of accuracy in determining this site is paramount so that an excessive amount of viable tissue is not destroyed adjacent the site. For example, the average arrhythmogenic site consists of about 1.4 cm² of endocardial tissue, whereas a reentrant site might be much larger. RF ablation techniques produce lesions about 0.5 cm² of diameter, so a number of lesions are typically generated in order to ablate the area of interest. If the site is not accurately mapped, much of the viable tissue surrounding the site will be unnecessarily destroyed.

[0005] To determine the location of the tissue to be ablated, it is widely known to use elongated intravascular signal sensing devices that are advanced through the patient's vasculature until the distal portions of the device are disposed within one or more of the patient's heart chambers, with one or more electrodes on the distal portion of the device in contact with the endocardial lining. Such devices may also be advanced within a patient's coronary artery, coronary sinus, or cardiac vein. Sensing devices such as those disclosed in U.S. Pat. No. 5,967,978 to Littmann et al., and combination sensing-ablation devices such as those disclosed in U.S. Pat. No. 6,002,956 to Schaer are typical.

[0006] Guiding catheters such as those disclosed in U.S. Pat. Nos. 6,021,340 and 5,775,327 to Randolph et al. may be used to rapidly advance such devices into a patient's cardiac vein draining into the coronary sinus. A particular advantage of the catheters disclosed in these references is the presence of an inner lumen and distal port on the catheter shaft, which, in conjunction with a distal balloon, allows for the deployment of contrast fluid distal to the distal end of the catheter for visualizing the venous structure.

[0007] The following U.S. Patents discuss related devices and methods for their use: U.S. Pat. Nos. 5,509,411, 5,645,

064, 5,682,885, 5,699,796, 5,706,809, and 5,701,298, each to Littmann et al; U.S. Pat. Nos. 5,881,732 and 5,645,082, each to Sung et al; U.S. Pat. No. 5,766,152 to Morely et al; U.S. Pat. Nos. 5,782,760 and 5,863,291, each to Schaer; U.S. Pat. No. 5,882,333 to Schaer et al., and U.S. Pat. No. 6,122,552 to Tockman et al.

[0008] However, despite the advantages of these sensing devices and guiding catheters, it remains quite difficult to accurately and reliably contact the various curved shapes one encounters in the endocardial lining. This is due to the frequent inability to customize the shape of their distal portion, or at least the inability to instantaneously and accurately adjust their shape upon demand during deployment to conform to the shape of the tissue of interest.

[0009] Concerns similar to those described above are associated with the placement of leads within the heart and other areas of the coronary vasculature. For example, pacemakers, defibrillator/cardioverters, and other implantable medical device (IMDs) may employ one or more electrodes that are maintained in contact with a patient's heart muscle and through which electrical stimulation of the heart muscle is achieved. Such devices typically employ a flexible conductive lead that connects a remotely positioned and implanted power source to the one or more electrodes. Secure placement of the electrodes in the selected heart chamber (typically the right atrium) or in a coronary vein or artery is required to assure appropriate and reliable depolarization or "capture" of cardiac tissue by electrical stimuli delivered by the IMD.

[0010] Many problems exist with reliably and accurately placing medical electrical leads and other similar devices such as catheters within the heart and associated vasculature. For instance, when placing transvenous leads or catheters, it is often difficult to engage the coronary sinus and sub-select the proper vessel into which the lead or catheter is to eventually be placed. Moreover, once placed, transvenous devices suffer from a relatively high rate of dislodgment from sites adjacent to, or on, the epicardium. Such dislodgment may result in a loss of capture or, at best, a reduction of the degree of electrical coupling between the electrode and the myocardium. More accurate and secure placement of the lead or catheter would not only reduce the difficulty and time associated with lead placement, but would reduce the risk of subsequent dislodgment as well.

[0011] There thus is a need for a method and system for placing intralumenally-deployed devices such as electrophysiology catheters and leads into selected areas of the coronary vasculature in a highly accurate and reliable fashion.

BRIEF DESCRIPTION OF THE DRAWINGS

[0012] FIG. 1A is a side cutaway view of a delivery sheath of the present invention.

[0013] FIG. 1B is a cross-sectional view of a delivery sheath of the present invention.

[0014] FIGS. 2A-2B are side and cross-sectional views, respectively, of a balloon catheter of the present invention.

[0015] FIG. 3 is a side view illustrating components included in both the deflection mechanism and micro-deflection mechanism of the present invention.

[0016] FIGS. 4A-4B are various views of a deflection mechanism handle of the present invention.

[0017] FIG. 5 is a cross-sectional side view of three components of the present invention: a deflection mechanism, an outer sheath, and a balloon catheter with an inflated distal balloon and a deflected distal end.

[0018] FIGS. 6A-6D are various views of a micro-deflection mechanism handle of the present invention.

[0019] FIGS. 7A-7B are two embodiments of deflection and micro-deflection mechanisms detailing two notch configurations.

[0020] FIGS. 8A-8D are additional embodiments of deflection and micro-deflection mechanisms of the present invention, detailing additional notch configurations.

[0021] FIG. 8E is a cross-sectional view of a deflection and micro-deflection mechanism having a tubular member with an irregular wall thickness to provide a preferred bending direction.

[0022] FIGS. 9-11 depict a method for accurately placing an endocardial lead into the cardiac venous system through the coronary sinus ostium using a system of the present invention.

[0023] FIG. 12 is a plan view of a steerable catheter that may be used as an alternative deflection mechanism to navigate the balloon catheter 200 into the coronary sinus.

[0024] FIGS. 12A through 12C illustrate various deflection positions of the distal tip of the steerable catheter of FIG. 12.

DETAILED DESCRIPTION OF THE INVENTION

[0025] This invention is a method and system for intraluminal visualization and deployment of implantable medical devices (IMDs) such as transvenous leads, electrophysiology catheters and the like to various targeted regions of the body. The inventive system includes a sheath, a balloon catheter and associated deflection mechanism, and a micro-deflection device for highly accurate placement of the lead, catheter, or other device once the area of interest has been visualized.

[0026] In the following pages we provide a component-by-component description of a preferred variation of the invention followed by a description of a procedure for using this system to place a transvenous lead into the coronary veins. Although we detail an exemplary set of system components and a method for its use, additional system configurations, adaptations, and methods of use, some of which are also described herein, are within the scope of the invention.

[0027] In general, the intraluminal visualization system and micro-deflection device of the present invention includes a deflectable catheter that includes an inflatable member such as a balloon, and is insertable into a lumen of a delivery sheath. This sheath may be inserted into the body via a typical introducer as will be described in more detail. In a preferred use, a balloon catheter is guided by a deflection mechanism so that it may engage the coronary sinus ostium so that an occlusive venogram may be rendered. The outer sheath then slides over the balloon catheter into the

coronary sinus, and the balloon catheter is removed. Next, a lead with a micro-deflection mechanism is inserted into the sheath lumen so that the lead may be deployed at the desired location in the coronary veins. The micro-deflection mechanism disposed within the lead is used to provide rigidity to the lead and to allow a means to sub-select coronary vessels. The sheath preferably may be splittable along its longitudinal length so that it may be removed around the lead without disturbing it.

[0028] Delivery Sheath

[0029] FIG. 1A is a cutaway side view depicting a variation of the delivery sheath described above. As best seen in FIG. 1A, sheath 100 comprises an elongate shaft 102 containing a central lumen 104 throughout its length. The working length of sheath 100 comprises a distal section 110 and a proximal section 120, each of which comprises a polymeric material having differing flexibilities as described below. A distal end 112 of sheath 100 disposed adjacent distal section 110 also comprises the working length.

[0030] Near the proximal end of sheath 100, a hub 114 may be affixed to proximal section 120 by an adhesive or other suitable means. We prefer an ultraviolet-curable adhesive sold by Loctite Corp. of Rocky Hill, Conn. under the name UV 4201. We also prefer an adhesive sold by Dymax corp. of Torrington, Conn. under the trademark DYMAX. Hub 114 is made from any suitable medical-grade polymer, and is preferably injection molded and longitudinally scored or perforated so that it may be removed from around a device without disturbing that device. It may be molded in situ onto the proximal section 120 of shaft 102.

[0031] Hub 114 has an opening large enough to accommodate a special rotatable hemostatic valve (RHG) 118, to which it is detachably secured by, e.g., an annular ring on the valve 118 inner diameter. A central lumen 124 in RHV 118 is aligned and in fluid communication with the lumen of shaft 102. Lumen 124 has a diameter large enough to accommodate a balloon catheter and a typical lead connector, such as an IS-1-type connector. An optional side arm (not shown) may be disposed on RHV 118 in fluid communication with lumen 124. RHV 118 may also be splittable via a scoring or perforation as described above.

[0032] An annular polymeric collar 116 is disposed on the outside diameter of RHV 118 distal portion proximal to the point where hub 114 meets RHV 118. In this embodiment, rotation of collar 116 locks the RHV 118 to the hub 114.

[0033] FIG. 1B is a cross-sectional view of the delivery sheath of FIG. 1A. As shown in FIG. 1B, a cross-section of shaft 102 in the distal section 110 reveals shaft lumen 104. The inner diameter of shaft 102 will vary depending on the outer diameter of the balloon catheter and the lead, each of which should be capable of passing through lumen 104. Typically the shaft inner diameter is between about 0.080 and 0.110 inch; more preferably it is about 0.098 inch. Likewise, the outer diameter of shaft 102 is typically between about 0.090 and 0.130 inch; more preferably it is about 0.118 inch. We prefer the outer diameter of shaft 102 to be as small as possible while still maintaining acceptable performance levels according to the application for which the shaft is used. We also prefer that shaft 102 generally maintains a constant inner diameter throughout its length to provide a smooth and continuous step-free profile for the passage of various devices and materials therethrough as described herein.

[0034] Tubing comprising distal section **10** and proximal section **120** will typically be polymeric, and is preferably any typical medical grade, biocompatible tubing with the appropriate performance characteristics as described herein. An especially desirable material is an extruded polyether block amide of the type sold by Atochem North America, Inc., Philadelphia, Pa. under the trademark PEBAX.

[0035] Distal and proximal sections **110** and **120**, respectively, are constructed of tubing having a durometer hardness ranging from about **20D** to **100D** (shore). The working length of shaft **102** preferably is composed of materials having two or more stiffnesses, although shaft **102**, having a single stiffness value throughout its length is within the scope of the invention.

[0036] In one embodiment, proximal section **120** comprises a relatively high stiffness material (typically about **72D**) in comparison to the more flexible distal section **110** (typically about **40D**). Although not shown in the view of **FIG. 1B**, distal section **110** and proximal section **120** may be comprised of a DACRON (E.I. du Pont de Nemours and Company, Wilmington, Del.) braid with a TEFLON (E.I. du Pont de Nemours and Company, Wilmington, Del.) liner. The braid is surrounded by the PEBAX tubing as described above, which renders the proximal section **120** of shaft **102** generally stiffer and less flexible than distal portion **110**.

[0037] Distal end **112** is preferably a soft, atraumatic tip made from a relatively low stiffness polymeric material so to prevent injury to the intima of the vessel walls or to other tissue. We have found an effective material for distal end **112**. A material well-suited for the distal end is a thermoplastic polyurethane elastomer such as PELLETHANE (Dow Chemical Co., Midland, Mich.) or the like.

[0038] According to one aspect of the invention, distal portion **110** may be radiopaque. This can be achieved by the inclusion of radiopaque metals or their alloys into the structure, or more preferably by incorporating radiopaque powders such as BaSO₄, BiCO₃, etc. into the polymer comprising distal portion **110**. Distal end **112** is preferably more radiopaque than distal portion **110**. This can be achieved by the incorporation of greater quantities of radiopaque powder, for instance, into the tubing, or by the use of a different material having greater radiopacity than that used in distal portion **110**. This radiopaque feature allows the user to more readily visualize these portions of sheath **100** under fluoroscopy.

[0039] The entire length of shaft **102** (from distal end **112** to the far proximal end of RHV **118**) is typically between about 40 and 60 cm, and is preferably about 55 cm. Distal end **112** may be between about 0.2 cm and 0.5 cm long, while distal section **110** is generally between about 5 and 10 cm long, and is preferably about 8 cm long. Proximal section **120** is between about 35 and 50 cm long; preferably about 42 cm.

[0040] Both the working length of shaft **102** as well as the attached hub **114** may contain a perforation or score **126** along their longitudinal axes. Alternatively, they may be otherwise configured to split so that they may be opened and removed from around an inserted device such as a lead or electrophysiology catheter without having to axially slide the sheath **100** relative to the device. A special tool may be used to facilitate such splitting, or the sheath/hub (and even

RHV **114**) combination may be split by hand without the aid of any special device. The splittable valve and sheath combinations as described in U.S. Pat. No. 5,312,355 to Lee is exemplary.

[0041] Balloon Catheter

[0042] Turning now to **FIGS. 2A-2B**, a balloon catheter **200** of the present invention is shown in side view and distal cross-sectional view, respectively. This catheter is largely similar to the guiding catheters disclosed in U.S. Pat. Nos. 6,021,340 and 5,775,327 to Randolph et al, the entirety of each of which are incorporated herein by reference, as well as the VUEPORT family of balloon occlusion guiding catheters sold by Cardima, Inc. of Fremont Calif.

[0043] Catheter **200** is designed to pass through the central lumen **104** of deployment sheath **100**, and reach the therapeutic site as a combined unit with sheath **100** and deflection mechanism **300**.

[0044] As shown in **FIGS. 2A and 2B**, balloon catheter **200** generally includes an elongated shaft **202**, a distal shaft section **204**, a proximal shaft section **206**, and an inner lumen **208**. A female luer lock **210** may be disposed on the proximal end of shaft **202** and secured by a suitable adhesive **212**, such as UV-curable Loctite **4201**.

[0045] A distal port **214** is provided in the distal end **216** of the catheter shaft that is in fluid communication with the inner lumen **208**. Proximal of distal end **216** is an occlusion balloon **211** axially disposed in the distal section **204** about catheter shaft **202**. The catheter shaft **202** is provided with an inflation lumen **209** that extends through the shaft **202** to the interior of the balloon **211** to direct inflation fluid therein.

[0046] On the proximal end of catheter **200**, proximal to luer lock **210**, is a multiarm adapter or hub **222** that terminates in a Y-adapter or hemostasis valve **232** and a proximal port **218** for passage of a deflection mechanism therethrough as described later.

[0047] A first sidearm or port **224** on adapter **222** (shown in partial cross section in **FIG. 2A**) facilitates introduction of inflation fluid into inflation lumen **209**. A stopcock **228** on first sidearm **224** that allows balloon **221** to stay inflated once the proper volume of fluid (such as air) has been introduced via syringe **230** is disposed adjacent stopcock **228**. Inflation lumen **209** is disposed in port **224** and extends distally into shaft **224** to facilitate inflation of balloon **211** as described above.

[0048] A second sidearm or port **226** may also be disposed on hub **222**, and may be in direct fluid communication with large inner lumen **208**. Inner lumen **208** is used for housing devices such as a deflection mechanism or the like. Once balloon **211** is inflated, the second port **226** may be used for introducing contrast media or similar material through lumen **208** and out the distal port **214** for visualization of a section of interest in the body, such as an organ lumen or the cardiac venous system, for instance.

[0049] Not shown is a rotatable hemostatic valve (RHV) that may be housed in the proximal center port **218** and that can accept devices such as a deflection mechanism described below. This RHV is capable of sealing onto the deflection mechanism to prevent fluid leakage and may be part of a duostat modified to comprise a single RHV and two sideports. Other configurations, of course, are possible.

[0050] Shaft **202** of balloon catheter **200** is of a sufficient size so that it may readily pass through the lumen **104** of sheath **100**. Ideally, we prefer the outer diameter of shaft **202** to be between approximately 0.050 inch and 0.100 inch. More preferably, it is between 0.060 inch and 0.080 inch, and most preferably is about 0.074 inch.

[0051] The diameter of inner lumen **208** preferably is large enough to allow free passage of contrast media or other material therethrough so that venograms and similar diagnostic procedures may be readily accomplished. It should also be large enough for the passage of a deflection mechanism as discussed below in greater detail. Finally, lumen **208** should allow the free passage of contrast media or other agents therethrough while occupied by a device such as a deflection mechanism. In general, we prefer that inner lumen have a diameter of between 0.030 inch and 0.080 inches, and is preferably about 0.048 inch. Likewise, inflation lumen **209** preferably has a diameter of between about 0.005 inch and 0.020 inch, and preferably is about 0.014 inch.

[0052] The balloon catheter shaft **202** preferably comprises PEBAX tubing having a durometer hardness of between about **60D** and **80D**, preferably about **72D**. Preferably, shaft proximal section **206** has a heat shrink tubing disposed on the outer surface thereof. Preferably, this heat shrink tubing is polymeric and is comprised of clear polyolefin or the like. Distal tip **216** is preferably a soft, atraumatic tip made of a relatively flexible polymeric material similar in composition and stiffness to distal tip **112** of sheath **100**. In one embodiment, distal tip is radiopaque.

[0053] The working length of balloon catheter shaft **202**, which includes the distal tip **216**, distal section **204**, and proximal section **206**, should be between about 50 cm and 90 cm, although it may be longer or shorter depending upon the application. We especially prefer a working length of approximately 70 cm which can accommodate a distal tip **216** of approximately 0.5 cm, a distal section **204** of approximately 6 cm, and a proximal section **206** of approximately 63.5 cm.

[0054] The length of the entire catheter **200** in this embodiment (the working length of shaft **202** and the components disposed proximal of proximal section **206** discussed above) should be about 77.5 cm. In general, we prefer that the balloon catheter shaft **202** be between about 15 cm and 20 cm longer than sheath **100**.

[0055] Of course, the absolute and relative lengths of each component of catheter **200** may vary considerably. The particular application in which catheter **200** and the entire system of the present invention is to be used will dictate the particular dimensions and materials for its various components (as well as each of the components of the inventive system) described herein.

[0056] Occlusion balloon **211**, when inflated, should have a diameter sufficient to seal the coronary sinus ostium. This inflated diameter will typically be between about 0.2 inch and 1.0 inches, and more preferably, between about 0.4 inch and 0.8 inches. We prefer balloon **211** to comprise an inelastic or elastic polymeric material. Polyurethane (e.g. PELLETHANE **80A** durometer, World Medical, Inc., Miami Fla.) is especially preferable. The inner diameter of the uninflated balloon **211** typically will be between about 0.04 inch and 0.08 inches, and more preferably between about

0.056 inch and 0.070 inches. The balloon wall thickness typically will be between about 0.002 inch and 0.006 inches, and more preferably about 0.004 inches. Finally, the balloon **211** length typically will be between about 6 mm and 14 mm, and more preferably between about 8 mm and 12 mm.

[0057] Deflection Mechanisms and Micro-Deflection Mechanism

[0058] The deflection mechanism and the micro-deflection mechanism are two separate components of the present invention. Deflection mechanism **300** is designed for use in the balloon catheter **200**, and is similar in many respects to the microdeflection mechanism **400**, only larger. Micro-deflection mechanism **400** is designed for use in a variety of applications where precise control and deflection of a device such as a lead, electrophysiology catheter, or other similar IMDs, is needed. Its small size relative to deflection mechanism **300** renders it useful in a wide range of applications in which its small size and flexibility may be relied upon.

[0059] FIG. 3 is a plan view illustrating components of both the deflection and micro-deflection mechanisms, although it will be described in terms of the deflection mechanism **300** for discussion purposes. Deflection mechanism **300** generally comprises a proximal section **304**, a distal section **306**, and a distal tip **308**. Adjacent the proximal section **304** is handle **310**, a preferred variation of which is shown in detail in FIGS. 4A and 4B.

[0060] Deflection mechanism **300** is designed to be placed through proximal port **218** of the balloon catheter **200** and into the inner lumen **208** such that the deflection mechanism distal tip **308** generally reaches distal section **204**, and preferably distal tip **216**, of balloon catheter shaft **202**. When the handle **310** is activated, the distal section **306** of deflection mechanism **300** deflects in a predetermined fashion, thus deflecting the distal section **204** of the balloon catheter in a similar fashion. In this way, balloon catheter **200** (or any device into which deflection mechanism **300** is disposed) may be torqued to conform to the particular lumen or cavity into which it is disposed.

[0061] Shaft **302** of deflection mechanism **300** comprises a tubular member such as hypotube **312**, preferably made of metallic biocompatible material such as medical grade stainless steel, titanium, nitinol, alloys of these, or any suitable material as known to those of skill in the art. Hypotube **312** preferably has an outside diameter small enough to fit within inner lumen **208** of catheter **200** and is preferably less than 0.048 inch. As shown in FIG. 3, hypotube **312** is beveled to form a strain relief **316** at the distal end of hypotube **312**. Of course, this particular configuration of hypotube **312**, as well as other aspects of the FIG. 3 deflection mechanism **300**, is merely exemplary. Other configurations that serve the purposes of this invention are within the scope of this disclosure as well.

[0062] Disposed within a central lumen of hypotube **312** is a pull wire **320**, which can be a stainless steel, titanium, nitinol or other metal or alloy or even polymeric wire which when pulled activates the deflection of distal section **306** of deflection mechanism **300**. Pull wire **320** is attached to a flat spring **322**, which is disposed in the distal section **306** of deflection mechanism **300**. Spring **322** is attached to hypotube **312** using any suitable attachment method, such as welding, brazing, soldering, adhesives, or the like as is

known to those of skill in the art. Spring 322 may be brazed to hypotube 312 along braze zone 314 as seen in FIG. 3. Likewise, any similar suitable attachment techniques may be used to attach pull wire 320 to spring 322. In one embodiment, the pull wire and spring are brazed to one another in braze zone 318 as seen in FIG. 3.

[0063] Distal deflection region 306 is preferably covered with compliant polymeric medical grade tubing, such as polyester, PEBAX, and tetrafluoroethylene. Especially preferred is a polymer of tetrafluoroethylene hexafluoropropylene and vinylidene fluoride known by its acronym as THV. This prevents fluid intrusion into the deflection mechanism.

[0064] In an especially useful variation of the invention in which the system is used for implanting a lead, the balloon deflection mechanism 300 will be of sufficient diameter to provide rigidity to the balloon catheter 200 during introduction into the coronary sinus ostium. The curve reach and deflection range should be sufficient to provide easy introduction into the coronary sinus ostium, and the entire assembly should provide adequate pull strength to deflect and torque the distal portion 204 of balloon catheter shaft 202 during manipulation into the coronary sinus ostium.

[0065] Turning now to FIGS. 4A-4B, a useful variation of handle 310 for manipulating deflection mechanism 300 is shown. Handle 310 includes body 324 and activation mechanism 326. Activation mechanism 326 may be manipulated by pushing distally or pulling proximally along a longitudinal axis of handle 310. The machined parts of these components may be polymeric. For example, a thermoplastic such as the acetyl homopolymer DELRIN (E.I. du Pont de Nemours and Company, Wilmington, Del.) may be used for this purpose. The molded parts may be formed of polymeric materials such as ABS (acrylonitrile butadiene styrene) or the like. A proximal end of pull wire 320 is disposed in a central lumen 328 of handle 310 and affixed into handle by means known to those of skill in the art.

[0066] Handle 310 is preferably lightweight and ergonomically configured for simple, one-handed operation. The deflection range (the maximum angular displacement the distal tip 308 undergoes when displaced from a straight and undeflected zero-degree position) may be between about 90 degrees and 180 degrees, preferably between about 100 degrees and 135 degrees. Further details of the features and versatility of distal section 306 will be described in greater detail below, as well a detailed description of how deflection is achieved.

[0067] FIG. 5 depicts three components of the inventive system described above in a partial cross-section. Deflection mechanism 300 with handle 310 is shown disposed in the inner lumen of balloon catheter shaft 202 via the proximal port 218 as previously described. In turn, the combination deflection mechanism 300 and balloon catheter 200 are disposed in the lumen 104 of sheath 100. In FIG. 5, the distal section of balloon catheter shaft 202 is shown in a deflected state via the action of the hypotube/pull wire mechanism. Notice also that distal balloon 211 is inflated with fluid provided through balloon fluid port 224. An RHV 118 for outer peel-away sheath 100 as discussed herein is seen as a flush port 130 disposed on RHV 118. For purpose of clarity, sheath hub 114 is not shown.

[0068] In general, there is no limit to the size of the deflection mechanisms described herein. All of the related

components are readily scalable to larger or smaller sizes than those disclosed here as would be apparent to one of ordinary skill in the art and as the particular application demands.

[0069] Turning now to a more specific discussion of micro-deflection mechanism 400 depicted generally in FIG. 3, the features of this element are largely similar to those of deflection mechanism 300. The features are generally smaller so that they may be used within devices such as leads, electrophysiology catheters, and the like as will be described below.

[0070] The micro-deflection mechanism utilizes a hypotube configuration as shown in FIGS. 7A, 7B, and 8A through 8E. We prefer the outer diameter of the microdeflection mechanism hypotube (not shown) to be between about 0.012 inch and 0.030 inch; preferably between about 0.014 inch and 0.026 inch; most preferably about 0.015 inch. This will allow introduction of the hypotube into a conventional IS-1 lead connector, as well as allow for movement of the hypotube within the entire length of the central lumen of a lead body without causing any undue stress or damage to any of the lead or catheter components.

[0071] We also prefer that the micro-deflection mechanism 400 pull wire, which is also preferably stainless steel or nitinol, have an outer diameter of between 0.005 and 0.015 inches, and more preferably between about 0.006 and 0.010 inches. Most preferably, the outer diameter is about 0.008 inch.

[0072] During deflection, we prefer that the distal-most 10 mm to 30 mm of the assembly 400 deflect, which in a preferred application, will allow the lead into which assembly 400 is placed to engage the coronary sinus ostium. Due to the smaller size and greater maneuverability, assembly 400 may deflect through angles as high 360 degrees and even 450 degrees or more. Such a high angular deflection capability allows the mechanism 400 (and the device into which it may be deployed) to create a tight loop. These high-angle deflections are especially useful in electrophysiology applications in which the micro-deflection mechanism 400 may be deployed in a mapping/ablation microcatheter to effect circumferential ablation patterns and the like in areas such as the cardiac pulmonary vein.

[0073] FIGS. 6A-6D depict various components of an especially useful variation of micro-deflection mechanism 400 handle 414. As shown in FIG. 6A, handle 414 includes a body 416 and an activation mechanism 418 that may be manipulated by pushing distally or pulling proximally axially along a longitudinal axis of handle 310. The handle has a relatively small preferred length that may be in the range of 2 inches. This scales well with the other, smaller components of micro-deflection mechanism 400, and also allows for simple, one-hand fingertip operation by a physician. Of course, the sizes may be sized as needed in a manner discussed above.

[0074] Micro-deflection mechanism 400 can be used to replace the fixed-curve stylet generally used to provide a deflectable lead or catheter. This deflectable lead or catheter may be more precisely placed in the targeted region of the cardiac venous system, overcoming the problems of state-of-the-art systems. In addition, the microdeflection mechanism may be used in conjunction with the other components

of the inventive system describe herein for deflectable electrophysiological catheters.

[0075] Turning now to features that are common to both the deflection mechanism **300** and micro-deflection mechanism **400** (hereinafter referred to in this generic discussion as simply “deflection mechanism”), each operates on the same principal based on a hypotube/pull wire assembly. The pull wire runs through the middle of the hypotube and is attached, via brazing or the like, at the distal end of the deflection mechanism.

[0076] The hypotube is allowed to deflect in a predetermined pattern by a series of slots, or kerfs, cut into the hypotube distal section. U.S. Pat. No. 5,507,725 to Savage et al, U.S. Pat. Nos. 5,921,924 and 5,441,483 both to Avitall, U.S. Pat. No. 4,911,148 to Snowski et al, U.S. Pat. No. 5,304,131 to Paskar, the entirety of each which are hereby incorporated by reference, describe various medical devices in which some type of notch is used to effect deflection.

[0077] **FIGS. 7 and 8** depict two variations of notch patterns that are useful in the present invention. Because of the scalability of these features, they are useful in both the deflection assembly **300** as well as micro-deflection assembly **400**.

[0078] In reference to **FIGS. 7 and 8**, and the following discussion, note that due to the drawing space constraints, the “proximal section” of the hypotube refers to a portion of the deflection mechanism that is proximal only in that it is disposed proximal to the corresponding distal section. It is possible that a considerable length of the hypotubes depicted in **FIGS. 7 and 8** exists proximal to the so-marked “proximal section”.

[0079] In **FIGS. 7A and 7B**, two hypotube/pull wire combinations are shown in top and side views, starting from the top of the page, respectively. **FIG. 7A** depicts an assembly **700** in which a pull wire **704** is brazed, soldered, or otherwise affixed to the distal end of hypotube **702** at hypotube distal section **708**. Note that pull wire **704** is deployed inside hypotube **702**. The pull wire is disposed in the interior of hypotube **702** all the way to the hypotube distal section **708** where it is affixed to hypotube **702** as described above. In general, pull wire **704** is affixed in handle **310** such that when the handle is activated, hypotube distal section **708** will deflect on the same side on which notches **710** (or as discussed below, the reduced wall thickness of hypotube) are located.

[0080] Each notch or kerf **710** is progressively deeper as one moves from the proximal end **706** of hypotube **702** to the distal end **708**. This particular feature will cause the hypotube to deflect in a smooth consistent curve. Note that the spacing between notches **710** is constant, and the only dimension of each notch **710** that changes its depth. The width remains constant. Each of these parameters may vary as performance requires.

[0081] Further, the centroids of each notch are aligned along a single, straight linear longitudinal axis as one moves from proximal section **706** to distal section **708**. This axis along which the notches are aligned may be nonlinear. For instance, the axis may be sinusoidal to effect a serpentine deflection profile, with a constant or varying pitch, or the axis may have some other curvilinear or even stepwise shape. Regardless of whether the notch centroids are aligned

along a linear or nonlinear axis, the centroid of each notch does not have to line up along such an axis.

[0082] Note also that the distance between adjacent notches as one moves from one end of a notch to the other end of hypotube of **FIG. 7A** remains constant. That is, the longitudinal axes of the notches are parallel to one another. This aspect of the notches or kerfs may also change depending upon the application.

[0083] Another variable that may affect the shape and performance characteristics of the assembly **700** is the depth to which the notches **710** are cut into the hypotube. For instance, in the assemblies of **FIGS. 7A and 7B**, the notches are cut completely through the wall thickness of hypotube **702**. This need not be the case. It is within the scope of the invention to provide notches in hypotube **702** in which a discrete amount of material is removed from the hypotube without penetrating through the hypotube thickness. A wide variety of depth profiles and patterns in etching each notch is therefore envisioned.

[0084] Taking this concept one step further, hypotube **702** need not contain a series of notches or kerfs to achieve the desired preferential distance deflection shape and response. For instance, it is within the scope of the invention to preferentially machine or etch the bulk of hypotube **702** in an asymmetric fashion so that when the pull wire **704** is activated, the distal section **708** of hypotube **702** deflects in a predetermined pattern. In other words, the wall thickness of hypotube **702** can be made to vary a function of length and/or circumferential position in patterns ranging from a simple tapering pattern to complex patterns in which correspondingly intricate and complex deflection shapes and resources may be had. Such a concept can be used alone or in conjunction with the use of notches or kerfs as described herein.

[0085] Each of the parameters described above, as well as other parameters such as hypotube wall thickness, material selection, etc. may be chosen to effect a particular deflection pattern and response depending upon the application for which the hypotube/pull wire assembly (such as assembly **700**) is intended. Furthermore, variations in many of these parameters from notch-to-notch may also be made. For instance, one notch may have a rectangular profile, while another notch on the same hypotube may have a circular profile, etc.

[0086] Software may be utilized to aid the designer, by way of mathematical algorithms and the like, to ascertain the optimal profile for hypotube **702** given a desired deflection shape, etc. For instance, a designer may be able to choose the application for which the assembly is to be used, and the software may select a number of alternative shapes from which the designer may choose. Once a deflection shape is chosen, the software will then calculate the optimal hypotube profile.

[0087] **FIG. 7B** shows an assembly **750** in which hypotube **752** and pull wire **754** are arranged in a similar fashion to those described above and shown in **FIG. 7A**. The only difference in the assembly of **FIG. 7B** is that the constant spacing between the notches **756** is larger than that in the assembly of **FIG. 7A**. This increased but constant spacing between notches **756** results in hypotube **752** being slightly heavier, since less material has been cut away from the

hypotube. When assembly **750** is deflected, this means that distal section **760** will deflect through a smaller angle with a larger curve diameter (although the deflection shape will generally be similar as that of the deflected assembly **700** due to the similar size, shape, and orientation of the notches in each assembly) than that experienced by assembly **700** in **FIG. 7A** for a given deflection force.

[**0088**] Turning now to **FIGS. 8A through 8E**, additional variations of a notch pattern are shown (the pull wire is omitted for clarity). In **FIG. 8A**, hypotube **810** with proximal section **812** and distal section **814** contains a series of linear notches **816** similar to those of **FIGS. 7A and 7B**, except that each end of notches **816** contain a secondary notch **818** oriented generally perpendicular to notch **816**. This notch design causes the distal section **814** of hypotube **810** to deflect in a similar fashion as described above, possibly with a tighter curve diameter.

[**0089**] The hypotube of **FIG. 8B** is identical to that of **FIG. 8A**, except that the notch pattern begins closer to the proximal section **822** of hypotube **820**. A longer length of hypotube distal section **824** will therefore deflect when activated by the pull wire.

[**0090**] **FIG. 8C** is a plan view depicting an embodiment of deflection mechanism wherein the notches are arranged in a non-linear manner. For example, a sinusoidal pattern is depicted, although many other types of patterns are possible.

[**0091**] **FIG. 8D** is a plan view depicting an embodiment of deflection mechanism wherein the notches are of different shapes and sizes. For example, the notches may be circular, triangular, rectangular, or any other pattern desired to allow the deflection mechanism to assume a desired shape when tension is applied to the pull wire. The notches may all have a uniform shape and size, or alternatively, may have different shapes and/or sizes.

[**0092**] **FIG. 8E** is a cross-sectional view depicting an embodiment of the deflection member wherein the hypotube has walls that are not of a consistent thickness. The thinner region of the wall defines a preferred bending direction when tension is applied to the pull wire. In one embodiment, both a thinner wall thickness and the creation of notches in the thinner region may be used to provide the deflection mechanism in the hypotube or other tubular member.

[**0093**] The notches or kerfs described herein and shown in the figures, as well as the varying wall thickness of the hypotube, may be created by any means known to those of skill in the art. They may be machined by traditional, laser, electron-discharge, or similar machining methods, they may be chemically etched, etched using known photolithographic techniques, etc.

[**0094**] A particularly useful feature in the deflection mechanisms described herein is the active control feature of the deflection mechanism handle (both handle **310** as well as handle **414**). Once the handle activation mechanism is engaged to deflect the distal section as described above, the deflection can be reversed only by the positive input of a user to disengage the same activation mechanism. In one embodiment of the deflection mechanism described above and shown in **FIGS. 4A-4B** and **FIGS. 6A-6D**, release of the activation mechanisms **326** and **418** after these mechanisms are deployed results in the distal section remaining in a deflected position. Reversal of this deflection requires that

the physician-user retract the activation mechanism, whereupon the distal section **306** will resume the undeflected state until the handle is activated once again. This feature allows the physician-user to manipulate other portions of the inventive system or to perform other tasks while the distal section **204** of balloon catheter **200**, for example, remains in the intended deflected or undeflected state. Of course, it is within the scope of the invention to design the handle so that activation to deflect distal section is automatically reversed to return the distal portion to a default undeflected state. This may be accomplished by a bias spring or equivalent mechanism that activates when the physician releases the positive input causing the initial deflection. Such a design may also bias the distal end of the deflection mechanism to automatically reverse to a default deflected position.

[**0095**] Another feature common to both handles **310** and **414** is the presence of one or more limit stops that may be built into the handle. These limit stops are designed to prevent over-deflection of the deflection mechanism.

[**0096**] Deployment of Cardiac Lead

[**0097**] Turning now to **FIGS. 9-11**, a particularly useful application for the system herein described is shown and is discussed below. In particular, a method for intravascularly deploying the system into the coronary sinus, obtaining an occlusive venogram, and accurately subselecting a venous branch and placing a cardiac lead therein is described.

[**0098**] To prepare for the procedure, balloon catheter **200** is inserted within the lumen **104** of outer sheath **100** to create a sheath/catheter combination. A deflection mechanism **300** is advanced into the large lumen **208** of the balloon catheter via proximal port **218** so that the distal tip **308** of the deflection mechanism shaft **308** is generally disposed in balloon catheter shaft **202** near shaft distal tip **216** as previously describe. This creates a combination sheath/catheter/deflection mechanism system as shown in **FIG. 5**. Typically, a portion of shaft **202** will extend out through and beyond the lumen **104** at the sheath **100** distal end **112** for some length.

[**0099**] This three-component system is introduced into the patient's venous system through the cephalic, subclavian or femoral vein via a conventional introducer as known to those of skill in the art. The physician uses the introducer to dilate the selected vein and then advance the system through the introducer into the selected vein.

[**0100**] Typically under fluoroscopic guidance, the physician navigates the three-component system through the vasculature to and through the superior vena cava **910** or inferior vena cava **940** (see **FIG. 9**) and into the heart **900** right atrium **920**. At this point, the distal tip **216** of shaft **202** and distal balloon **211** engage the coronary sinus ostium. The deflection mechanism is used to help steer the shaft **202** distal tip **216** into place. Balloon **211** is then inflated, and contrast is injected into the coronary veins through the distal port **214** of shaft **202**. This creates an occlusive venogram for visualizing the coronary veins in advance of placing the lead in the desired location.

[**0101**] Next, while balloon **211** is still in the coronary sinus, the outer sheath **100** is advanced into the coronary sinus over the catheter shaft **202** so that it may be available as a conduit for lead placement. Once the sheath **100** is in place, the balloon **211** is deflated and the balloon catheter

200 and the associated deflection mechanism **300** are proximally withdrawn from sheath **100**, leaving sheath **100** alone in place in the coronary sinus as shown in **FIG. 10**.

[**0102**] Next, the micro-deflection mechanism **400** is placed into a central lumen of a lead **600** so that the deflectable distal section of micro-deflection mechanism **400** generally engages the distal section of the lead **600**. The combination of these components is then advanced into the lumen **104** of sheath **100** and into the coronary sinus ostium as seen in **FIG. 11**. From here, the physician will activate the deflection mechanism to steer the lead/micro-deflection mechanism combination. In one embodiment, the micro-deflection mechanism may be used to subselect a venous branch into which the lead is to be permanently placed. Of course, the particular deflection shape and characteristics of micro-deflection mechanism have been selected by the physician for optimal use in navigating the venous system and creating the shape for the lead to assume during lead placement.

[**0103**] Once the lead **600** is placed and the pacing thresholds are acceptable, the RHV **118** is removed from the sheath and slid over the lead connector (alternatively, RHV **118** may be split). Next, preferably with the aid of a special slitting tool such as a customized razor blade attached to the sheath **100**, the sheath **100** and hub **114** are split along score **126** as the sheath is pulled away from the lead **600** and removed from the body.

[**0104**] Micro-deflection mechanism **400** may be withdrawn from the lead **600**, after which the lead **600** is the only component left in the body. Lead **600** remains in place, and may be coupled to a pulse generator, cardioverter/defibrillator, drug delivery device, or another type of IMD.

[**0105**] As discussed throughout the specification, the method outlined above is merely exemplary of one way to deploy a cardiac lead according to the present invention. Many alternative applications for the invention are possible. Significant variations from this technique may occur within the scope of the present invention.

[**0106**] For example, in one embodiment, the deflection mechanism that is adapted to be inserted within the balloon catheter is a steerable catheter such as an electrophysiology (EP) catheter. One example of a catheter having a suitable steering mechanism is the Mariner catheter commercially available from Medtronic Corporation.

[**0107**] **FIG. 12** is a plan view of a steerable catheter that may be used to navigate the balloon catheter **200** into the coronary sinus. The catheter **1000** is an anatomically-conforming, dual curve EP catheter used to sense electrical signals in the heart and associated vasculature. The catheter includes a shaft **1004** having an atraumatic distal end **1006** and a proximal end **1008**. Shaft **1004** may have an outside diameter of less than approximately 0.06 inches and a length of about 50 mm to 110 mm. Proximal end **1008** is mounted to a handle **1010** having axially slidable manipulator rings **1012** and **1013**, and a rotatable lateral deflection ring **1014** operably connected to proximal and distal manipulator wires carried by the body of the catheter. Sliding manipulator rings **1012** and **1013** cause a deflectable tip **1020** of catheter shaft **1004** to deflect as shown in **FIGS. 12A and 12B** between, for example, the solid-line and dashed-line positions of **FIG. 12B**. Rotating ring **1014** causes lateral deflection of tip **1020** through the torquing action of a core wire as shown in **FIGS. 12C**.

[**0108**] A steerable EP catheter of the type shown in **FIGS. 12 through 12C** is adapted to be inserted within the inner lumen of the balloon catheter, which in turn, is inserted within the lumen **104** of the outer sheath **100** to create an alternative sheath/catheter combination. As previously described, this assembly may be advanced into the chambers of the heart. Next, the EP catheter distal tip may be advanced beyond the distal end of the outer sheath to guide the balloon catheter into the coronary sinus. The range of motion provided by the steerable catheter as noted above makes it particularly suitable for cannulating the coronary sinus and utilizing the balloon catheter to obtain a venogram in the manner discussed above. Then the balloon catheter and the steerable catheter are removed from the sheath so that the sheath may be used to place an IMD with a microdeflection mechanism in the manner discussed above.

[**0109**] According to another aspect of the invention, the system described herein may be used for deploying a wide array of devices in the coronary venous structure, the pulmonary venous structure, or any organ with large enough vessels for the introduction of the system. In addition, the system can be used in extravascular applications such as in the deployment of cochlear implants, in body cavities, muscle tissue, and the like.

[**0110**] The balloon catheter **200** can be used for the introduction of drugs or other media or agents within a very discrete region of a vessel. Note that the balloon on the balloon catheter **200** described herein is optional. The deflectable catheter may be used without a balloon, for improved access and maneuverability.

[**0111**] With respect to the micro-deflection mechanism **400**, due to its ability to be scaled to a very small size, it may be used for interventions into the spinal column, tiny vessels in the brain, liver, kidney, or any other suitable organ. In addition, sensor such as electrodes for recording signals and possibly ablating tissue may be incorporated into the micro-deflection mechanism **400**. Fiber optics for the introduction of light for visualization or optical recording or sensing may be incorporated into either deflection mechanism.

[**0112**] The deflection mechanism may also be used to deliver drugs or other therapeutic or diagnostic agents or materials as described above.

[**0113**] Many alterations and modifications may be made by those having ordinary skill in the art without departing from the spirit and scope of the invention. The illustrated variations have been used only for the purposes of clarity and should not be taken as limiting the invention as defined by the following claims.

What is claimed is:

1. A deflection mechanism for delivery of devices and agents into a targeted area of the body, the deflection mechanism comprising:

- a) a shaft with a shaft lumen and a shaft wall comprising a proximal section, a proximal end, and a distal section with a distal tip, the distal section being capable of deflection;
- b) a pull wire assembly comprising a pull wire running through the shaft lumen, said pull wire being attached to a spring connected to the distal section of the shaft lumen; and

- c) a handle disposed at the proximal end of said shaft lumen for manipulating said pull wire, the deflection mechanism capable of being removably inserted into a catheter lumen of an electrophysiology catheter and capable of deflecting the electrophysiology catheter.
2. The deflection mechanism of claim 1, wherein the shaft is capable of deflecting in a predetermined pattern defined by a series of notches in the shaft wall.
3. The deflection mechanism of claim 1, wherein the shaft is capable of deflecting in a predetermined pattern defined by reduced thickness of a portion of the shaft wall.
4. The deflection mechanism of claim 2, wherein shaft deflection is determined by a series of notches of progressively increasing depth from the proximal end to the distal tip.
5. The deflection mechanism of claim 3, wherein shaft deflection is determined by reduced thickness of the shaft wall as a function of length, circumferential position, or length and circumferential position.
6. The deflection mechanism of claim 1, wherein the electrophysiology catheter is an ablation catheter.
7. The deflection mechanism of claim 1, wherein the electrophysiology catheter is an RF ablation catheter.
8. A system for mammalian intraluminal visualization and delivery, said system comprising:
- a sheath comprising an elongate member defining a lumen, said sheath comprising a proximal section and a distal portion with a distal end;
 - a balloon catheter comprising an inner balloon catheter lumen, an elongated shaft with a flexible distal shaft section and a proximal shaft section, a proximal port, a distal port in fluid communication with the catheter lumen, and an occlusion balloon axially disposed about the distal shaft section, said deflectable balloon catheter capable of being removably inserted into the sheath;
 - a deflection mechanism capable of being inserted into the inner balloon catheter lumen and deflecting the distal shaft section of the balloon catheter;
 - an electrophysiology catheter comprising an elongate member defining an electrophysiology catheter lumen, a flexible tip disposed distally on the elongate member, and an electrode disposed on an outer surface of the tip, the electrophysiology catheter capable of being removably inserted into the sheath; and
 - a microdeflection device capable of being inserted into the electrophysiology catheter lumen and deflecting the tip of the electrophysiology catheter.
9. The system of claim 8, wherein the electrophysiology catheter is an ablation catheter.
10. The system of claim 9, wherein the sheath distal portion is more flexible than the sheath proximal section and wherein the sheath distal portion is radiopaque.
11. The system of claim 8, wherein the deflection mechanism is a second steerable catheter.
12. The system of claim 11, wherein the second steerable catheter is an electrophysiology catheter.
13. A method for mammalian intraluminal visualization and delivery, said method comprising:
- providing a sheath comprising an elongate member defining a sheath lumen;
 - inserting a deflectable balloon catheter into the sheath lumen, said deflectable balloon catheter comprising an inner balloon catheter lumen, an elongated balloon catheter shaft with a flexible distal shaft section disposing a distal balloon catheter tip and a proximal shaft section, a proximal port, a distal port in fluid communication with the catheter lumen, and a balloon axially disposed about the distal shaft section;
 - advancing a deflection mechanism into the inner balloon catheter lumen through the proximal port to form a sheath/catheter/deflection mechanism system;
 - navigating the sheath/catheter/deflection mechanism to a target tissue of the target organ;
 - removing the deflection balloon catheter and associated deflection mechanism from the sheath;
 - advancing an electrophysiology catheter with an electrode and associated with a removably inserted microdeflection mechanism into the shaft lumen to form an electrophysiology catheter/microdeflection device/shaft mechanism,
 - activating the microdeflection mechanism to steer the electrophysiology catheter/microdeflection device/shaft mechanism to the target tissue; and
 - transmitting an electrical signal to the electrode.
14. The method of claim 13, wherein method d.) further includes the methods of:
- engaging the target tissue with sheath/catheter/deflection mechanism;
 - inflating the balloon;
 - injecting contrast fluid into the target tissue;
 - visualizing the target tissue; and
 - deflating the balloon.
15. The method of claim 13, wherein the electrophysiology catheter is an ablation catheter.
16. The method of claim 13, wherein the electrophysiology catheter is an RF ablation catheter.
17. A method of placing an implantable medical device within a body comprising the methods of:
- providing an assembly including a sheath having a sheath inner lumen, a guide catheter having an catheter inner lumen and disposed within the sheath inner lumen, and a deflection mechanism adapted to navigate the coronary sinus and being disposed within the catheter inner lumen;
 - navigating the assembly into the heart;
 - advancing the guide catheter and sheath beyond the distal end of the sheath inner lumen and into the coronary sinus;
 - advancing the sheath into the coronary sinus over the guide catheter;
 - withdrawing the guide catheter and deflection mechanism from the sheath inner lumen;
 - providing a second assembly including an implantable medical device (IMD) having an elongated structure and an IMD inner lumen, the second assembly further

including a microdeflection mechanism disposed within the IMD inner lumen;

- g.) advancing the second assembly into the sheath inner lumen and into the coronary sinus;
- h.) utilizing the microdeflection mechanism to place the IMD; and
- i.) withdrawing the microdeflection mechanism and sheath from the body.

18. The method of claim 17, wherein the guide catheter includes an inflatable member and a port for injecting contrast fluid, and wherein method c.) includes the methods of:

- inflating the inflatable member;
- injecting contrast fluid from the port;
- obtaining an image of the body in the vicinity of the injected contrast fluid; and
- deflating the inflatable member.

19. The method of claim 17, wherein the deflection mechanism is a steerable catheter.

20. The method of claim 19, wherein the deflection mechanism is an electrophysiology steerable catheter.

21. The method of claim 17, wherein the IMD of method f.) is a medical electrical lead.

22. The method of claim 17, wherein method h.) includes the method of utilizing the microdeflection mechanism to subselect a branch vein from within the coronary sinus.

23. A system for delivering an implantable medical device (IMD) to a body, comprising:

- a.) a sheath having an inner lumen;
- b.) a catheter having an inflation member and adapted to be slidably inserted within the sheath, the catheter having a catheter inner lumen;
- c.) a deflection mechanism adapted to be slidably inserted within the catheter and to cannulate the coronary sinus; and

- d.) an assembly adapted to be slidably disposed within the sheath when the sheath is positioned within the coronary sinus, the assembly comprising an IMD having an inner lumen and a microdeflection mechanism disposed within the IMD inner lumen, the microdeflection mechanism having a cutaway portion defining a preferred bending direction and being adapted to navigate the IMD within the coronary sinus.

24. The system of claim 23, wherein the IMD is a medical electrical lead.

25. The system of claim 24, wherein the deflection mechanism is an electrophysiology (EP) catheter.

26. The system of claim 25, wherein the cutaway portion of the microdeflection mechanism comprises multiple notches.

27. The system of claim 26, wherein the notches are equally-spaced.

28. The system of claim 27, wherein ones of the multiple notches each include an associated secondary notch.

29. The system of claim 28, wherein each of the ones of the multiple notches are substantially perpendicular to the associated secondary notch.

30. The system of claim 26, wherein the notches are substantially aligned along a longitudinal axis of the microdeflection mechanism.

31. The system of claim 26, wherein the notches have a similar shape with respect to one another.

32. The system of claim 26, wherein ones of the notches have a shape that is different from other ones of the notches.

33. The system of claim 23, wherein the microdeflection mechanism has a beveled distal end to provide strain relief.

34. The system of claim 23, wherein the sheath is split-table.

* * * * *

专利名称(译)	具有可偏转机制的腔内可视化系统		
公开(公告)号	US20010044624A1	公开(公告)日	2001-11-22
申请号	US09/822678	申请日	2001-03-30
[标]申请(专利权)人(译)	SERAJ MAHMOUD 陈ERIC KELLEY JAMES F		
申请(专利权)人(译)	SERAJ MAHMOUD K. 陈ERIC KELLEY詹姆斯·		
当前申请(专利权)人(译)	SERAJ MAHMOUD K. 陈ERIC KELLEY詹姆斯·		
[标]发明人	SERAJ MAHMOUD K CHAN ERIC KELLEY JAMES F		
发明人	SERAJ, MAHMOUD K. CHAN, ERIC KELLEY, JAMES F.		
IPC分类号	A61B18/14 A61M25/00 A61M25/01 A61M25/06 A61N1/05 A61B5/00		
CPC分类号	A61B18/1492 A61B2017/22038 A61M25/0051 A61M25/0054 A61M25/0138 A61M25/0147 A61M25/0668 A61M25/0042 A61M25/0047 A61M25/0081 A61M25/0161 A61M25/0681 A61M25/1052 A61M25/1079 A61N1/056 A61N2001/0578 A61N2001/0585		
优先权	60/193695 2000-03-31 US		
其他公开文献	US6743227		
外部链接	Espacenet USPTO		

摘要(译)

这是用于血管内进入和可视化身体结构的组合方法和系统。公开了一种系统，包括护套，球囊导管和导管偏转机构。还可以提供微偏转机构，其可以放置在诸如心脏导联或电生理学导管的装置的内腔中，用于将这种装置精确地引导和放置到它们的目标位置。在一个实施例中，描述了用于引线或导管放置的过程，其中组合偏转机构，球囊导管和护套组件通过上级方法进入冠状窦口。使导管上的远端球囊膨胀，并在荧光透视引导下获得闭塞性静脉造影以使冠状静脉可视化。鞘进入冠状窦口并使球囊放气。然后移除导管和偏转机构。接下来，已经插入心脏导管内腔的微偏转机构通过护套展开，允许导线在放置在所选位置时以高精度和控制进行偏转。

