



US009084611B2

(12) **United States Patent**  
**Amirana et al.**

(10) **Patent No.:** **US 9,084,611 B2**  
(45) **Date of Patent:** **Jul. 21, 2015**

- (54) **SYSTEMS AND METHODS FOR VISUALIZING ABLATED TISSUE**
- (71) Applicants: **The George Washington University**, Washington, DC (US); **LuxCath, LLC**, Boston, MA (US)
- (72) Inventors: **Omar Amirana**, Boston, MA (US); **Kenneth C. Armstrong**, Cary, NC (US); **Matthew W. Kay**, Kensington, MD (US); **Marco A. Mercader**, Arlington, VA (US); **Terrance J. Ransbury**, Chapel Hill, NC (US); **Narine Sarvazyan**, Potomac, MD (US)
- (73) Assignees: **The George Washington University**, Washington, DC (US); **LuxCath, LLC**, Boston, MA (US)
- (\* ) Notice: Subject to any disclaimer, the term of this patent is extended or adjusted under 35 U.S.C. 154(b) by 290 days.

(21) Appl. No.: **13/624,902**  
(22) Filed: **Sep. 22, 2012**

(65) **Prior Publication Data**  
US 2013/0079645 A1 Mar. 28, 2013

**Related U.S. Application Data**  
(63) Continuation-in-part of application No. 13/624,899, filed on Sep. 22, 2012, now Pat. No. 9,014,789.  
(60) Provisional application No. 61/537,798, filed on Sep. 22, 2011.

(51) **Int. Cl.**  
**A61B 18/14** (2006.01)  
**A61B 5/00** (2006.01)  
(Continued)

(52) **U.S. Cl.**  
CPC ..... **A61B 18/1492** (2013.01); **A61B 5/004** (2013.01); **A61B 5/0084** (2013.01);  
(Continued)

(58) **Field of Classification Search**  
CPC .. A61B 5/0059; A61B 5/0075; A61B 5/0084; A61B 5/0205  
USPC ..... 600/473, 476  
See application file for complete search history.

(56) **References Cited**  
**U.S. PATENT DOCUMENTS**  
5,749,830 A \* 5/1998 Kaneko et al. .... 600/160  
6,178,346 B1 \* 1/2001 Amundson et al. .... 600/473  
(Continued)

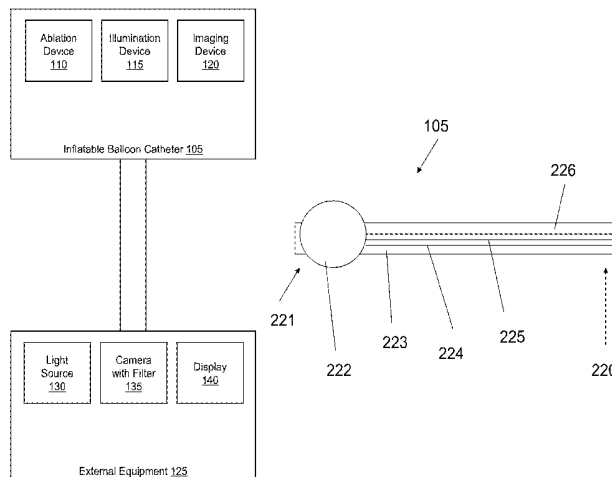
**FOREIGN PATENT DOCUMENTS**  
DE 10200521205 11/2006  
DE 102005021205 11/2006  
(Continued)

**OTHER PUBLICATIONS**  
Boersma LV, Wijffels MC, Oral H, Wever EF, Morady F. "Pulmonary vein isolation by duty-cycled bipolar and unipolar radiofrequency energy with a multielectrode ablation catheter". *Heart Rhythm* 5: 1635-1642, 2008.  
(Continued)

*Primary Examiner* — Peter Luong  
(74) *Attorney, Agent, or Firm* — Greenberg Traurig, LLP; David J. Dykeman; Roman Fayerberg

(57) **ABSTRACT**  
Systems and methods for visualizing ablated tissue are disclosed. In some embodiments, a system for imaging tissue comprising: a catheter having a distal end and a proximal end; an inflatable balloon disposed about the distal end of the catheter; and an optical housing extending from the distal end of the catheter into the balloon, the optical housing being configured to position inside the balloon a light source for illuminating a tissue outside the balloon and a camera for imaging the illuminated tissue.

**33 Claims, 21 Drawing Sheets**  
**(6 of 21 Drawing Sheet(s) Filed in Color)**



- (51) **Int. Cl.**  
*A61B 19/00* (2006.01)  
*A61B 18/00* (2006.01)  
*A61B 18/02* (2006.01)

- WO WO2006/028824 3/2006  
 WO 2007109554 9/2007  
 WO WO2007/109554 9/2007  
 WO 2008114748 9/2008  
 WO WO2008/114748 9/2008

- (52) **U.S. Cl.**  
 CPC ..... *A61B19/5202* (2013.01); *A61B 19/5212*  
 (2013.01); *A61B 2018/0022* (2013.01); *A61B*  
*2018/0212* (2013.01); *A61B 2019/2211*  
 (2013.01); *A61B 2019/5291* (2013.01)

OTHER PUBLICATIONS

(56) **References Cited**

U.S. PATENT DOCUMENTS

- 7,235,045 B2 6/2007 Wang et al.  
 7,534,204 B2 5/2009 Starksen et al.  
 7,598,088 B2 10/2009 Balas  
 7,640,046 B2 12/2009 Pastore  
 7,837,676 B2 11/2010 Sinelnikov et al.  
 7,930,016 B1 4/2011 Saadat  
 7,974,683 B2 7/2011 Balas et al.  
 8,050,746 B2 11/2011 Saadat et al.  
 8,078,266 B2 12/2011 Saadat et al.  
 8,131,350 B2 3/2012 Saadat et al.  
 8,137,333 B2 3/2012 Saadat et al.  
 8,188,446 B2 5/2012 Ohno  
 8,221,310 B2 7/2012 Saadat et al.  
 8,235,985 B2 8/2012 Saadat et al.  
 8,333,012 B2 12/2012 Rothe et al.  
 8,417,321 B2 4/2013 Saadat et al.  
 8,419,613 B2 4/2013 Saadat et al.  
 8,460,285 B2 6/2013 Wang  
 8,500,730 B2 8/2013 Lee  
 2003/0028188 A1\* 2/2003 Paddock et al. .... 606/41  
 2005/0197623 A1 9/2005 Leeflang et al.  
 2005/0228452 A1 10/2005 Mourlas et al.  
 2006/0184048 A1 8/2006 Saadat  
 2007/0015964 A1 1/2007 Eversull et al.  
 2007/0016130 A1 1/2007 Leeflang et al.  
 2007/0083217 A1 4/2007 Eversull et al.  
 2007/0167828 A1 7/2007 Saadat  
 2007/0287886 A1 12/2007 Saadat  
 2007/0293724 A1 12/2007 Saadat et al.  
 2008/0009747 A1 1/2008 Saadat et al.  
 2008/0015569 A1 1/2008 Saadat et al.  
 2008/0033241 A1 2/2008 Peh et al.  
 2008/0058650 A1 3/2008 Saadat et al.  
 2008/0097476 A1 4/2008 Peh et al.  
 2008/0119694 A1 5/2008 Lee  
 2008/0183036 A1 7/2008 Saadat et al.  
 2008/0214889 A1 9/2008 Saadat et al.  
 2008/0275300 A1 11/2008 Rothe et al.  
 2008/0281293 A1 11/2008 Peh et al.  
 2009/0030276 A1 1/2009 Saadat et al.  
 2009/0030412 A1 1/2009 Willis et al.  
 2009/0054803 A1 2/2009 Saadat et al.  
 2009/0062790 A1 3/2009 Malchano et al.  
 2009/0082623 A1 3/2009 Rothe et al.  
 2009/0125022 A1 5/2009 Saadat et al.  
 2009/0143640 A1 6/2009 Saadat et al.  
 2009/0203962 A1 8/2009 Miller et al.  
 2009/0221871 A1 9/2009 Peh et al.  
 2009/0227999 A1 9/2009 Willis et al.  
 2009/0253991 A1 10/2009 Balas et al.  
 2009/0275799 A1 11/2009 Saadat et al.  
 2009/0299363 A1 12/2009 Saadat et al.  
 2010/0084563 A1 4/2010 Ohno  
 2012/0150046 A1 6/2012 Watson et al.  
 2013/0102862 A1 4/2013 Mercader et al.  
 2013/0310680 A1 11/2013 Werahera

- International Search Report mailed Dec. 3, 2012 for PCT/US2012/056771.  
 Anderson et al. "Real-time spectroscopic assessment of thermal damage: implications for radiofrequency ablation". J Gastrointest Surg. 2004; 8: 660-669.  
 Asfour et al, "Signal decomposition of transmembrane voltage-sensitive dye fluorescence using a multiresolution wavelet analysis" IEEE Trans Biomed Eng. 2011; 58: 2083-2093.  
 Boersma et al., "Pulmonary vein isolation by duty-cycled bipolar and unipolar radiofrequency energy with a multielectrode ablation catheter". Heart Rhythm5:1635-1642, 2008.  
 Buch et al. "Epicardial catheter ablation of atrial fibrillation." Minerva Med. 2009; 100: 151-157.  
 Chance et al, "Fluorescence measurements of mitochondrial pyridine nucleotide in aerobiosis and anaerobiosis" Nature. 1959; 184: 931-4.  
 Coremans et al, "Pretransplantation assessment of renal viability with NADH fluorimetry", Kidney International, vol. 57, (2000), pp. 671-683.  
 d'Avila A. "Epicardial catheter ablation of ventricular tachycardia." Heart Rhythm. 2008; 5: S73-5.  
 Demos et al, "Real time assessment of RF cardiac tissue ablation with optical spectroscopy", Opt Express. 2008; 16: 15286-15296.  
 Dickfeld et al, "Characterization of Radiofrequency Ablation Lesions With Gadolinium-Enhanced Cardiovascular Magnetic Resonance Imaging" J Am Coll Cardiol. 2006; 47: 370-378.  
 Dukkupati et al, "Visual balloon-guided point-by-point ablation: reliable, reproducible, and persistent pulmonary vein isolation", Circ Arrhythm Electrophysiol. 2010; 3: 266-273.  
 Dumas et al, "Myocardial electrical impedance as a predictor of the quality of RF-induced linear lesions." Physiol Meas. 2008; 29: 1195-1207.  
 Fleming et al, "Real-time monitoring of cardiac radio-frequency ablation lesion formation using an optical coherence tomography forward-imaging catheter", Journal of Biomedical Optics, May/Jun. 2010, vol. 15(3).  
 Fleming et al, "Toward guidance of epicardial cardiac radiofrequency ablation therapy using optical coherence tomography" J Biomed Opt. 2010; 15: 041510.  
 Girard et al, "Contrast-enhanced C-arm CT evaluation of radiofrequency ablation lesions in the left ventricle", JACC Cardiovasc Imaging. 2011; 4: 259-268.  
 Grimard et al, "Percutaneous epicardial radiofrequency ablation of ventricular arrhythmias after failure of endocardial approach: a 9-year experience" J Cardiovasc Electrophysiol. 2010; 21: 56-61.  
 Henz et al, "Simultaneous epicardial and endocardial substrate mapping and radiofrequency catheter ablation as first-line treatment for ventricular tachycardia and frequent ICD shocks in chronic chagasic cardiomyopathy" J Interv Card Electrophysiol. 2009; 26: 195-205.  
 Himel et al, "Translesion stimulus-excitation delay indicates quality of linear lesions produced by radiofrequency ablation in rabbit hearts", Physiol Meas. 2007; 28: 611-623.  
 Kay et al, "Locations of ectopic beats coincide with spatial gradients of NADH in a regional model of low-flow reperfusion", Am J Physiol Heart Circ Physiol. 2008; 294: H2400-5.  
 Khoury et al., "Localizing and Quantifying Ablation Lesions in the Left Ventricle by Myocardial Contrast Echocardiography", J Cardiovasc Electrophysiol. 2004; 15: 1078-1087.  
 Kim et al, "Materials for multifunctional balloon catheters with capabilities in cardiac electrophysiological mapping and ablation therapy", Nat Mater. 2011; 10: 316-323.  
 Lardo, et al "Visualization and temporal/spatial characterization of cardiac radiofrequency ablation lesions using magnetic resonance imaging", Circulation. 2000; 102: 698-705.

FOREIGN PATENT DOCUMENTS

- WO 0172214 10/2001  
 WO WO01/72214 10/2001  
 WO 2006028824 3/2006

(56)

**References Cited**

## OTHER PUBLICATIONS

Li, "Multiphoton Microscopy of Live Tissues with Ultraviolet Autofluorescence", IEEE Journal of Selected Topic in Quantam Electronics, May/Jun. 2010, vol. 16, Issue 3, pp. 516-513.

Lo et al, "Three-dimensional electroanatomic mapping systems in catheter ablation of atrial fibrillation", Circ J. 2010; 74: 18-23.

Mayevsky et al. "Oxidation-reduction states of NADH in vivo: from animals to clinical use", Mitochondrion. 2007; 7: 330-339.

Melby et al, "Atrial fibrillation propagates through gaps in ablation lines: implications for ablative treatment of atrial fibrillation", Heart Rhythm. 2008; 5: 1296-1301.

Menes et al, "Laparoscopy: searching for the proper insufflation gas" Surg Endosc. 2000; 14: 1050-1056.

Meng et al "A comparative study of fibroid ablation rates using radio frequency or high-intensity focused ultrasound", Cardiovasc Intervent Radiol. 2010; 33: 794-799.

Mercader et al, "NADH as an Endogenous Marker of Cardiac Tissue Injury at the Site of Radiofrequency Ablation", The George Washington University, Washington DC, Mar. 18, 2011.

Mercader et al, "Use of endogenous NADH fluorescence for real-time in situ visualization of epicardial radiofrequency ablation lesions and gaps", Am J Physiol Heart Circ Physiol, May 2012; 302(10): H2131-H2138.

Nath et al, "Basic aspects of radiofrequency catheter ablation", J Cardiovasc Electrophysiol. 1994; 5: 863-876.

Niu et al, "An acute experimental model demonstrating 2 different forms of sustained atrial tachyarrhythmias". Circ Arrhythm Electrophysiol. 2009; 2: 384-392.

Perez et al. "Effects of gap geometry on conduction through discontinuous radiofrequency lesions" Circulation. 2006; 113: 1723-1729.

Ranji et al, "Fluorescence spectroscopy and imaging of myocardial apoptosis", Journal of Biomedical Optics 11(6), 064036 (Nov./Dec. 2006).

Ranji et al, "Quantifying Acute Myocardial Injury Using Ratiometric Fluorometry", IEEE Trans Biomed Eng. May 2009; 56(5): 1556-1563.

Riess et al, "Altered NADH and improved function by anesthetic and ischemic preconditioning in guinea pig intact hearts", Am J Physiol Heart Circ Physiol 283; H53-H60, Mar. 14, 2002.

Roger et al, "American Heart Association Statistics Committee and Stroke Subcommittee. Heart disease and stroke statistics—2011 update; a report from American Heart Association", Circulation 2011; 123: e18-e209.

Sosa et al, "Epicardial mapping and ablation techniques to control ventricular tachycardia". J Cardiovasc Electrophysiol. 2005; 16: 449-452.

Swartling et al, "Changes in tissue optical properties due to radio-frequency ablation of myocardium", Med Biol Eng Comput. 2003; 41: 403-409.

Swift et al, "Controlled regional hypoperfusion in Langendorff heart preparations". Physiol Meas. 2008; 29: 269-79.

Van Haesendonck C, Sinnaeve A, Willems R, Vandenbulcke F, Stroobandt R, "Biophysical and electrical aspects of radiofrequency catheter ablation". Acta Cardiol 50: 105-115, 1995.

Vetterlein et al, "Extent of damage in aschemic, nonreperfused myocardium of anesthetized rats", Am J Physiol Heart Circ Physiol 285: H755-H765, 2003.

Yokoyama et al, "Novel contact force sensor incorporated in irrigated radiofrequency ablation catheter predicts lesion size and incidence of steam pop and thrombus", Circ Arrhythm Electrophysiol. 2008; 1: 354-362.

Office Action issued in U.S. Appl. No. 13/624,899 mailed on Oct. 2, 2014.

\* cited by examiner

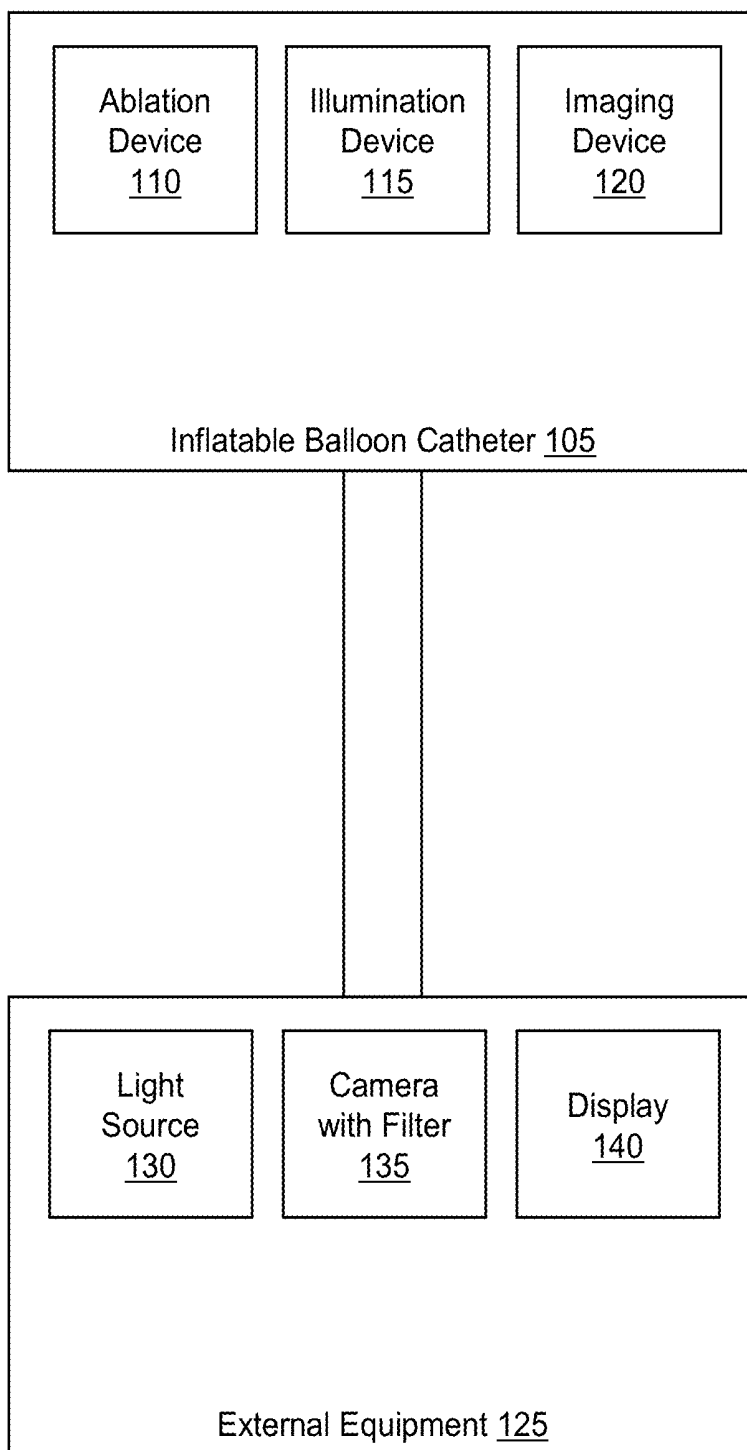


Figure 1A

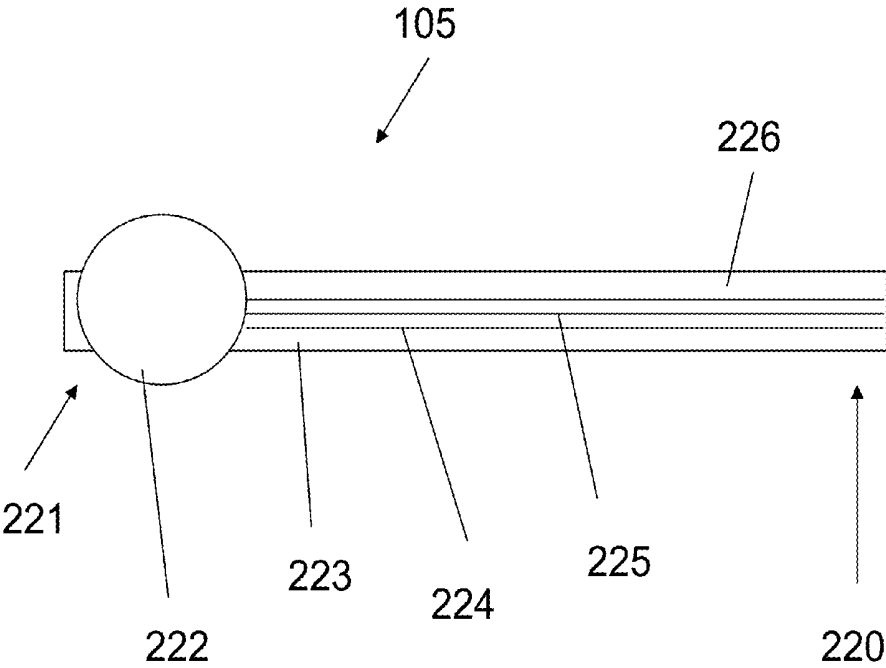


Figure 1B

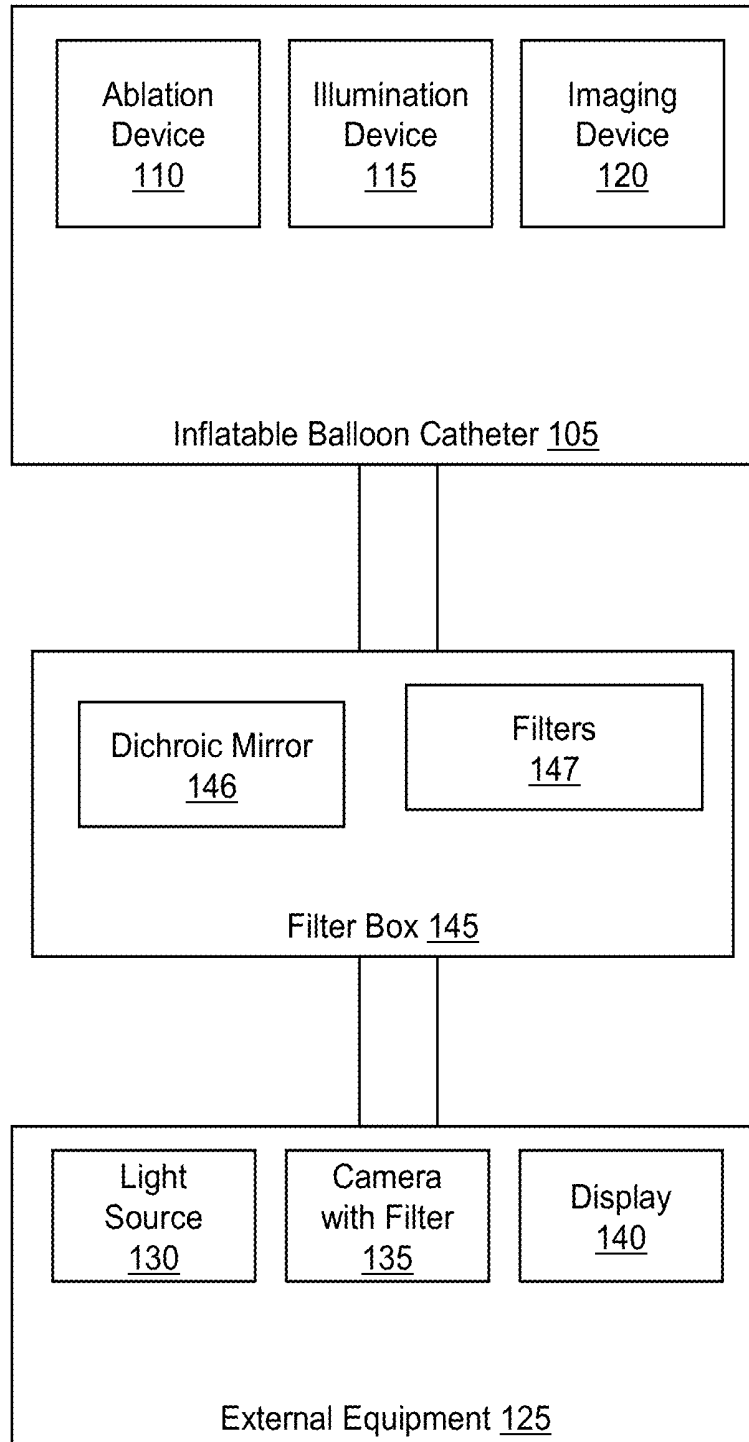


Figure 2A

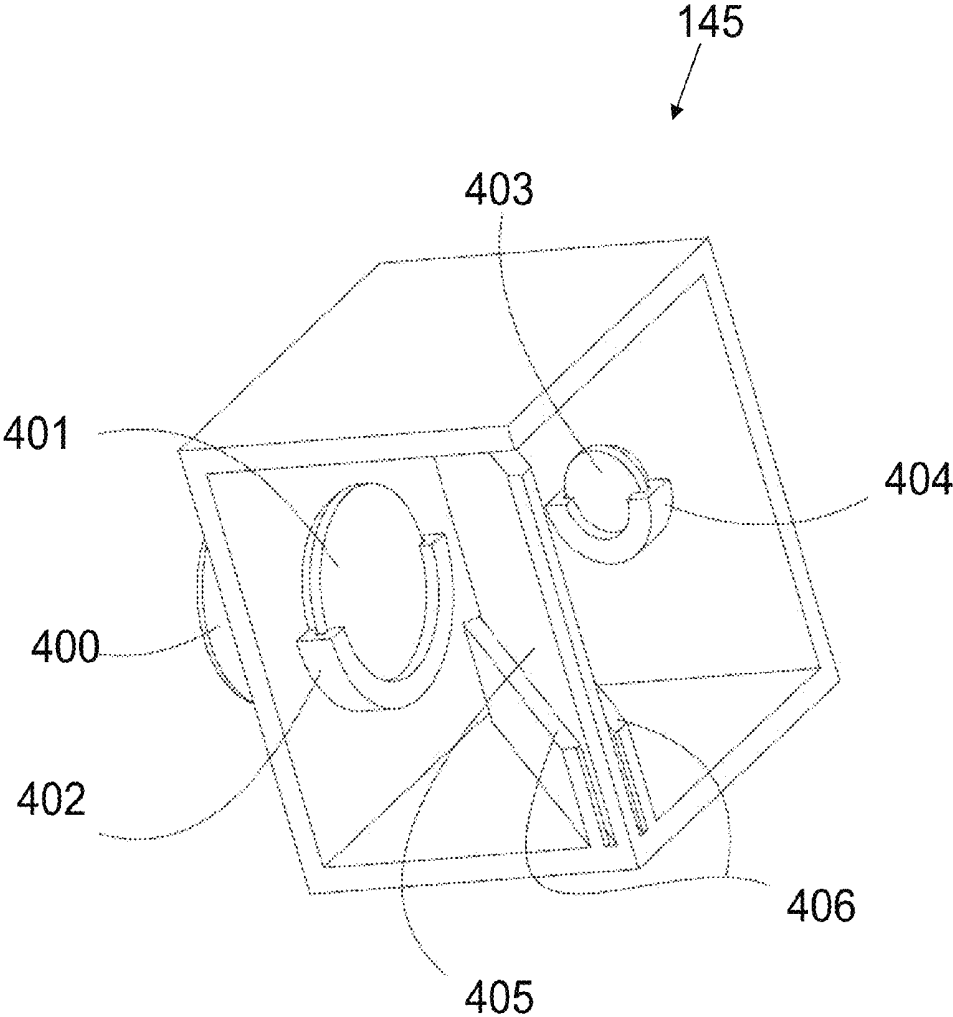


Figure 2B

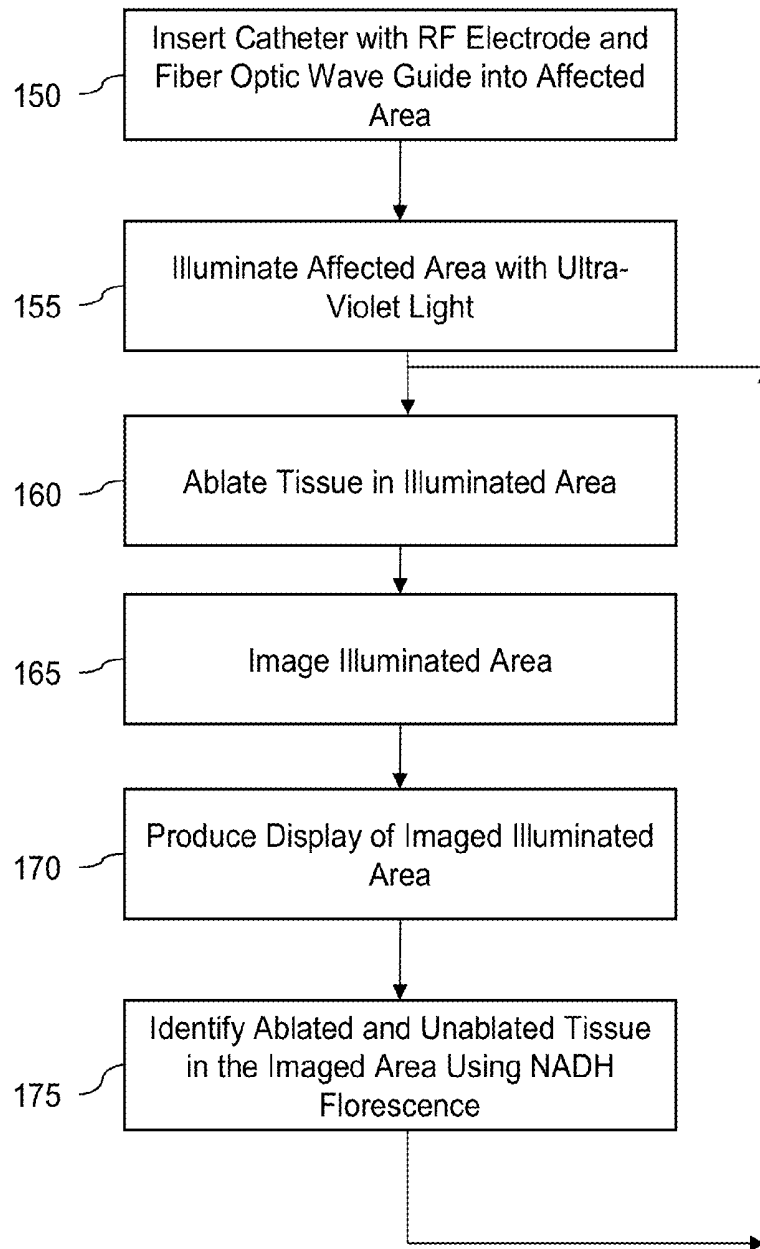


Figure 3

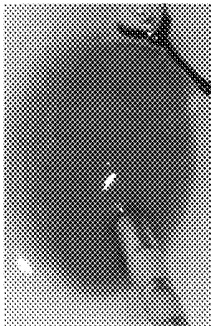


Figure 4A

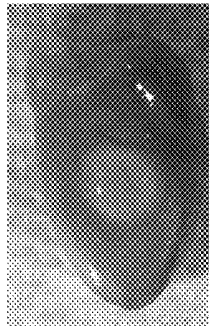


Figure 4B

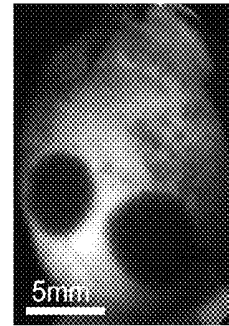


Figure 4C

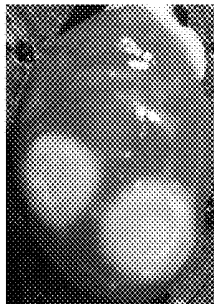


Figure 4D



Figure 4E

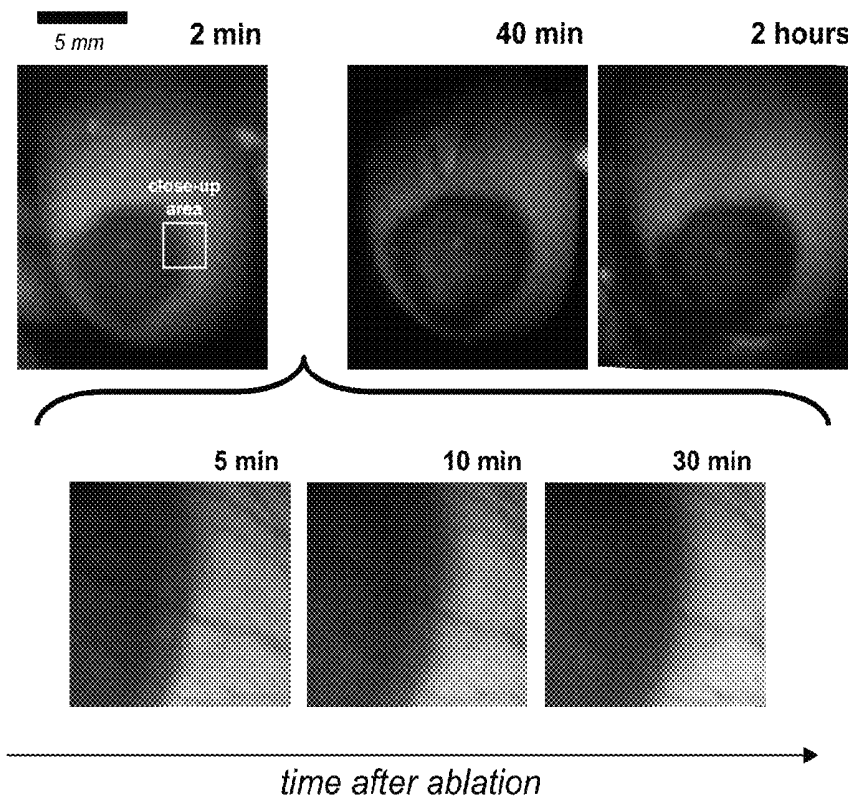


Figure 5A

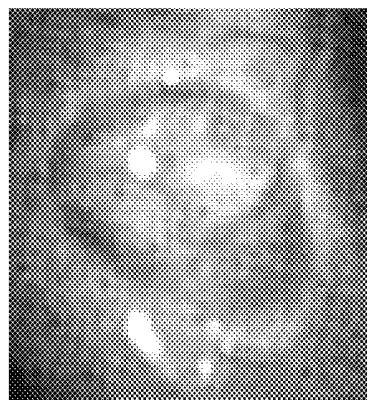


Figure 5B

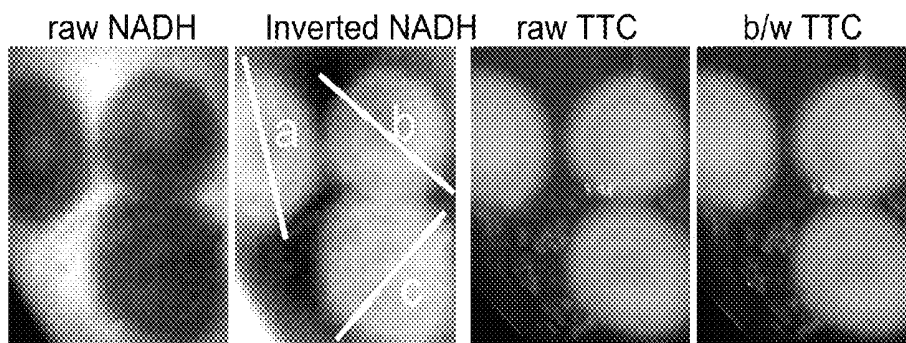


Figure 6A

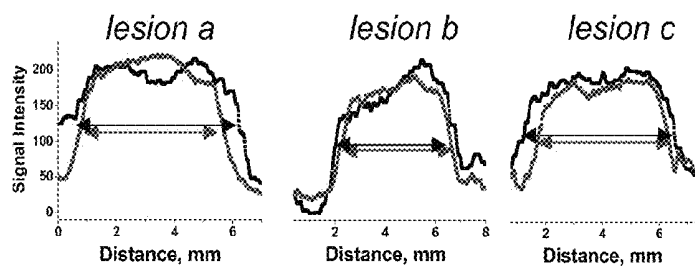


Figure 6B

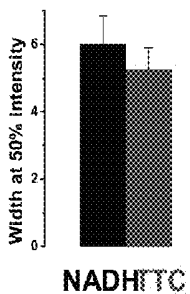


Figure 6C

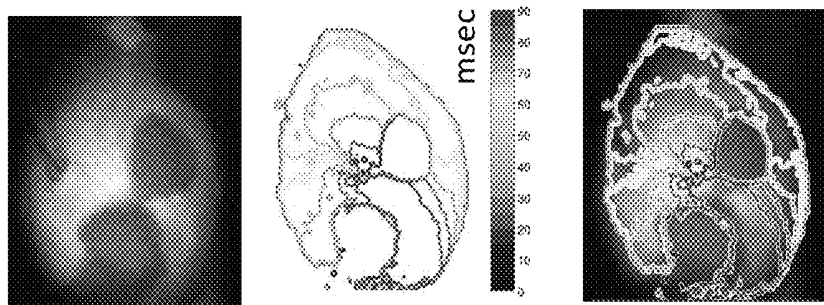


Figure 7A

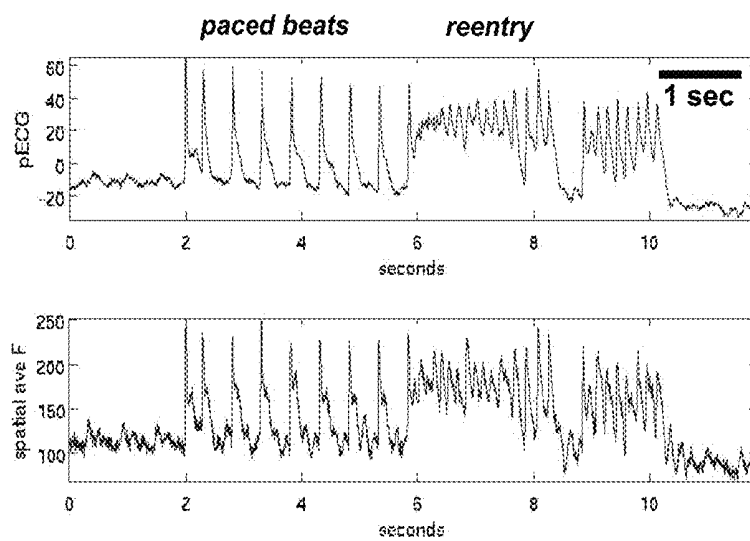


Figure 7B

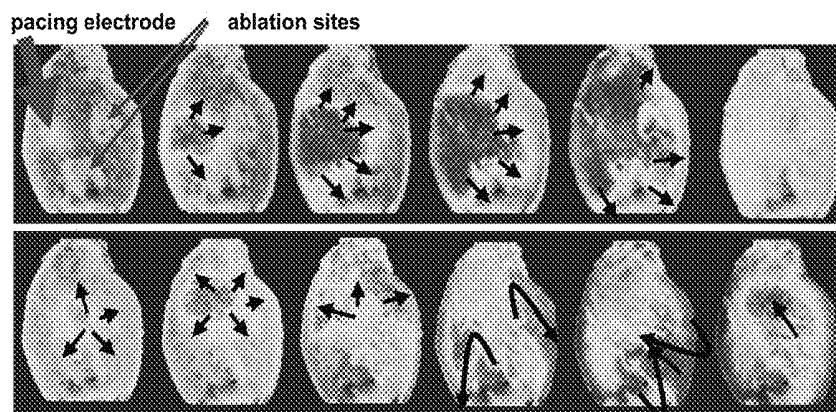


Figure 7C

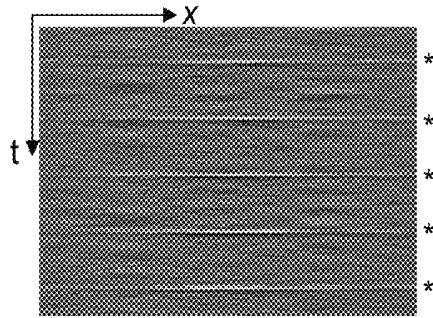


Figure 8A

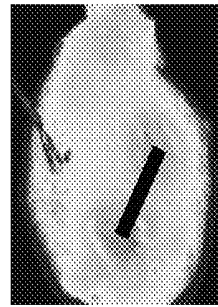


Figure 8B

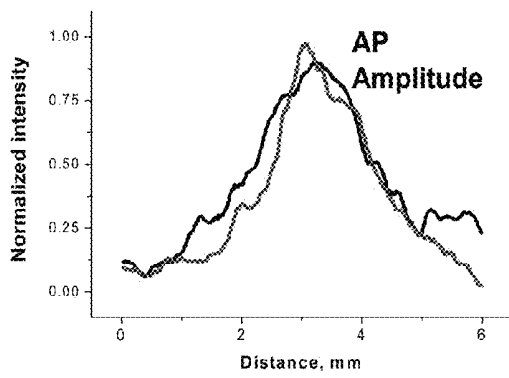


Figure 8C

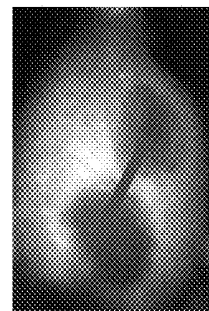


Figure 8D

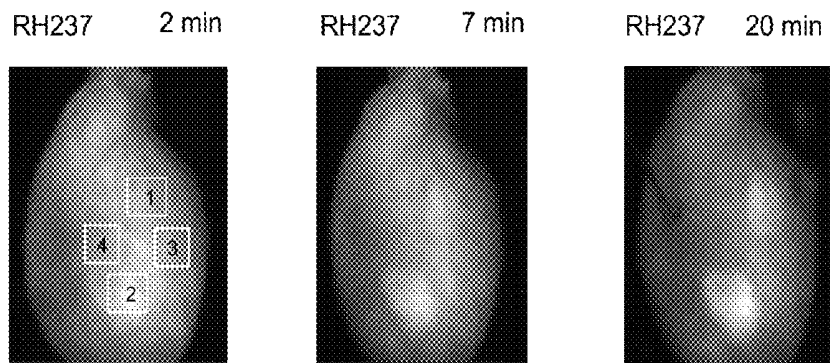


Figure 9A

Figure 9B

Figure 9C

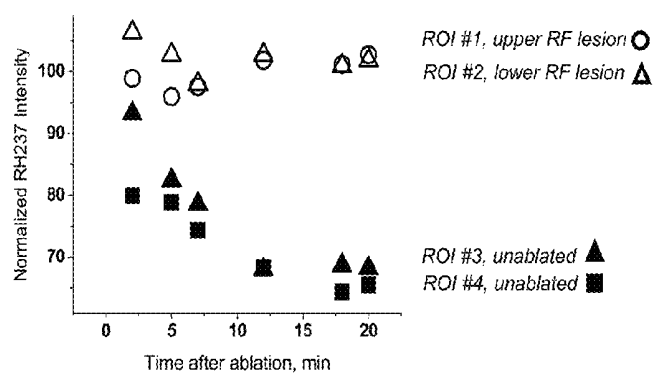


Figure 9D

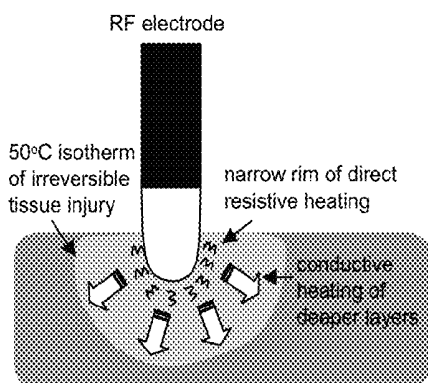


Figure 10A

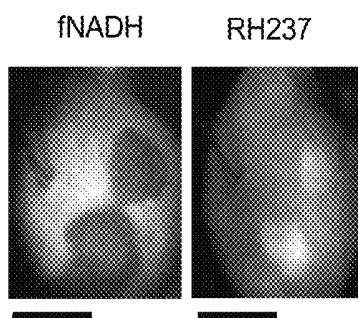


Figure 10B

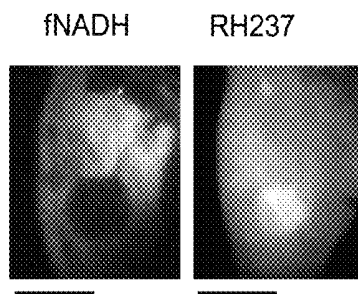


Figure 10C

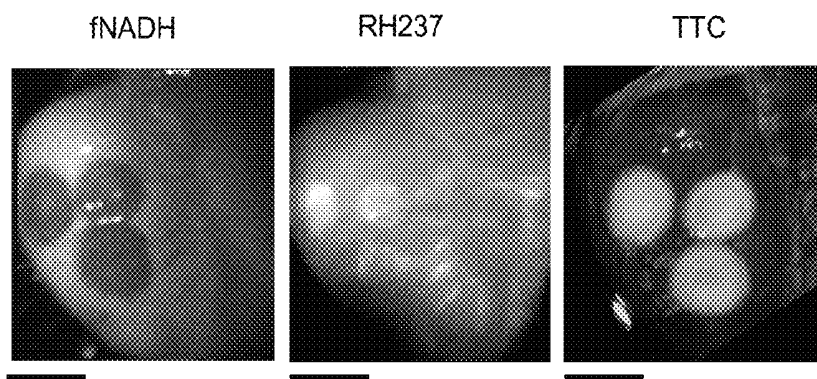
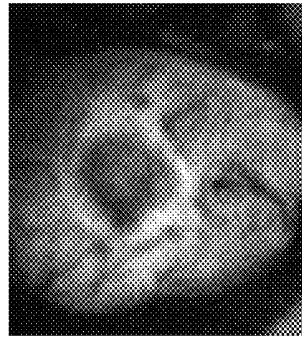


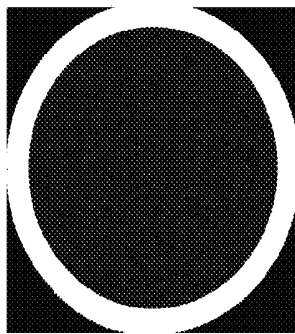
Figure 10D



**Figure 11A**

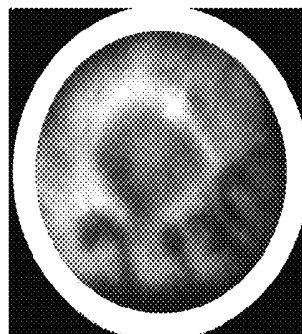


**Figure 11B**



*blood on top*

**Figure 11C**



*blood displaced*

**Figure 11D**



Figure 12

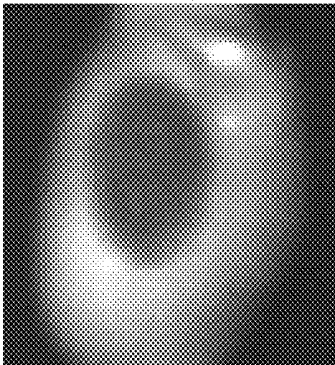


Figure 13

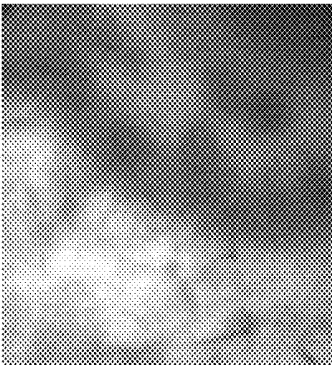


Figure 14

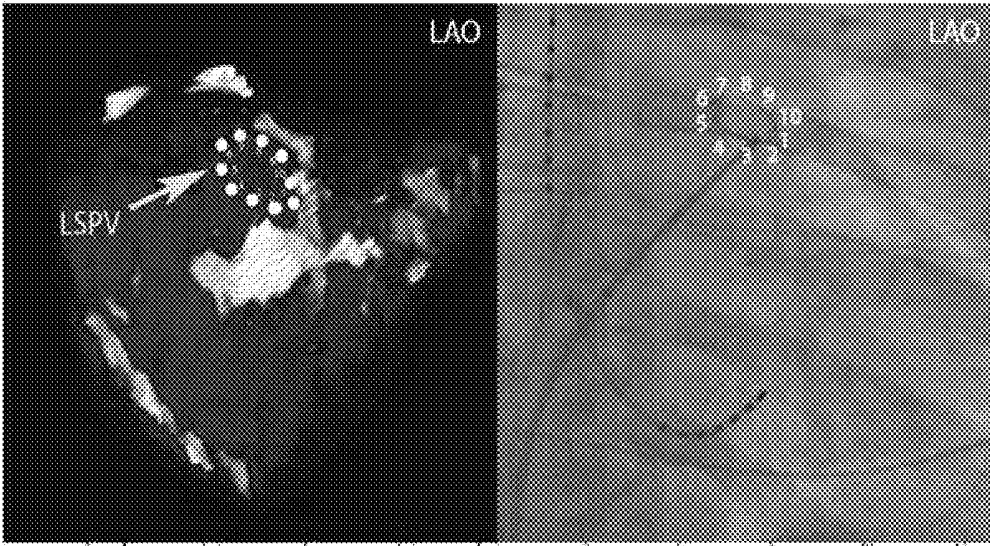


Figure 15

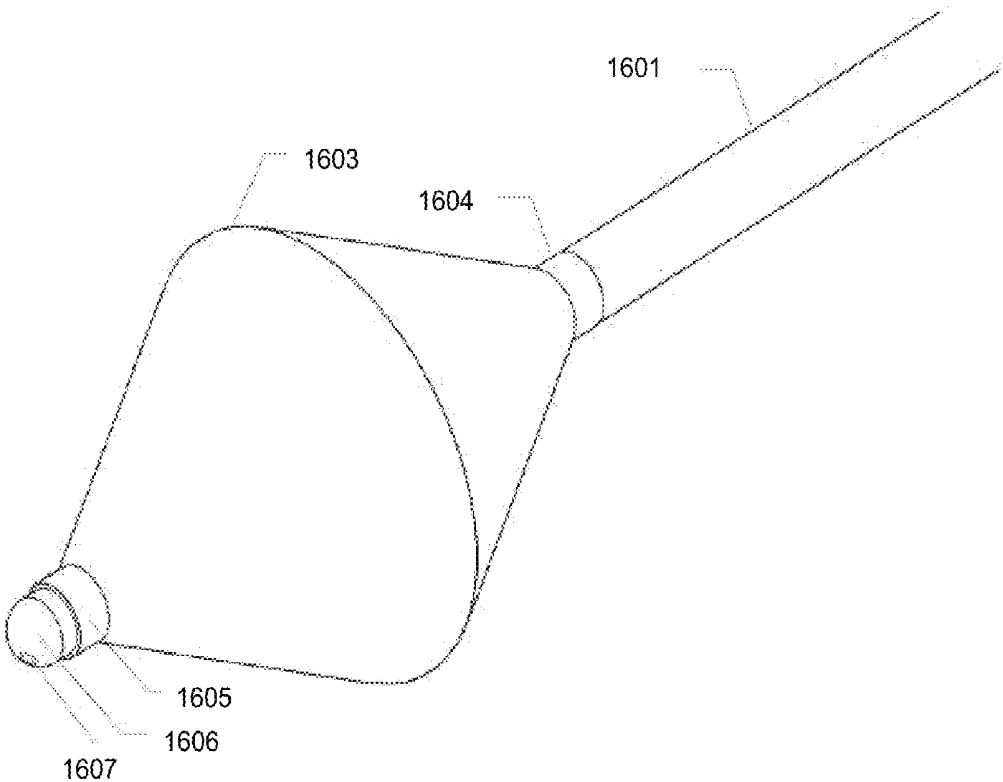


Figure 16

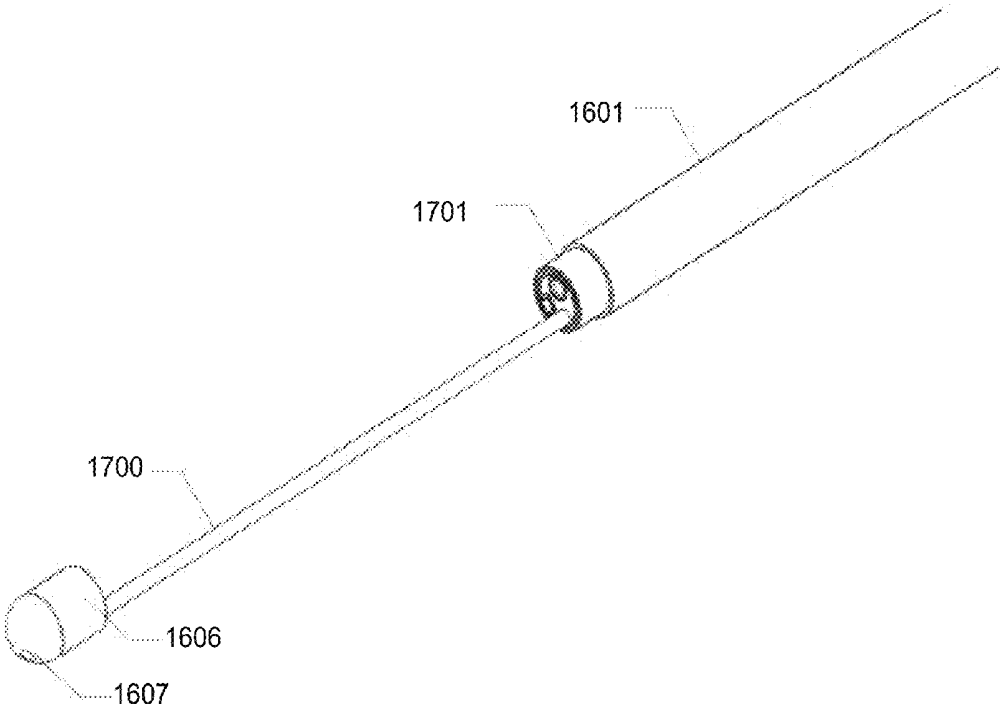


Figure 17

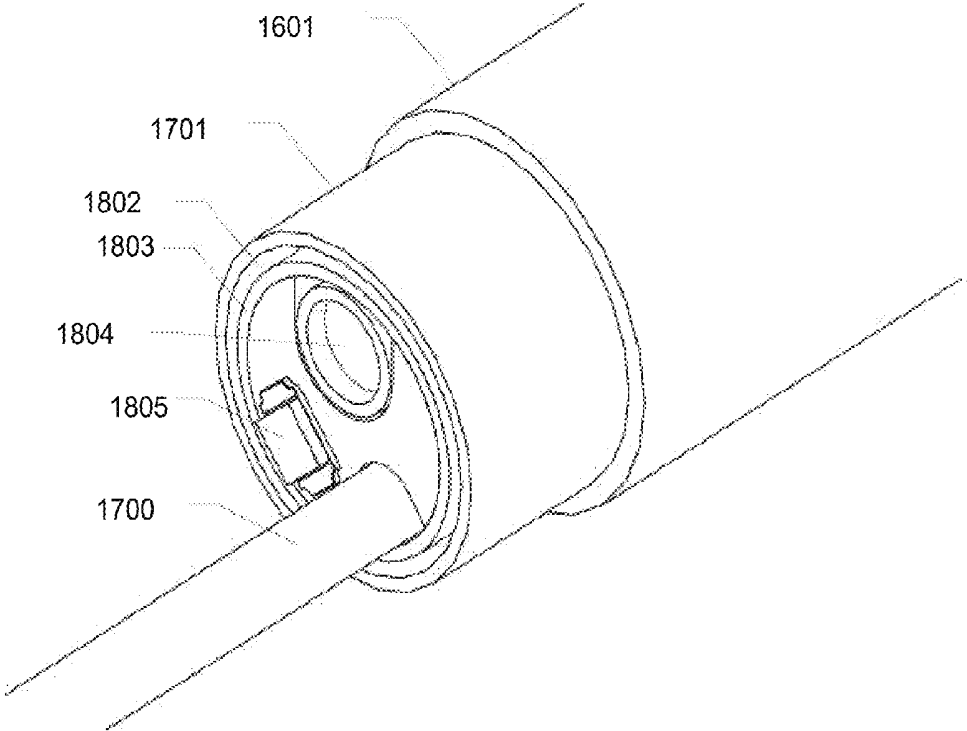


Figure 18

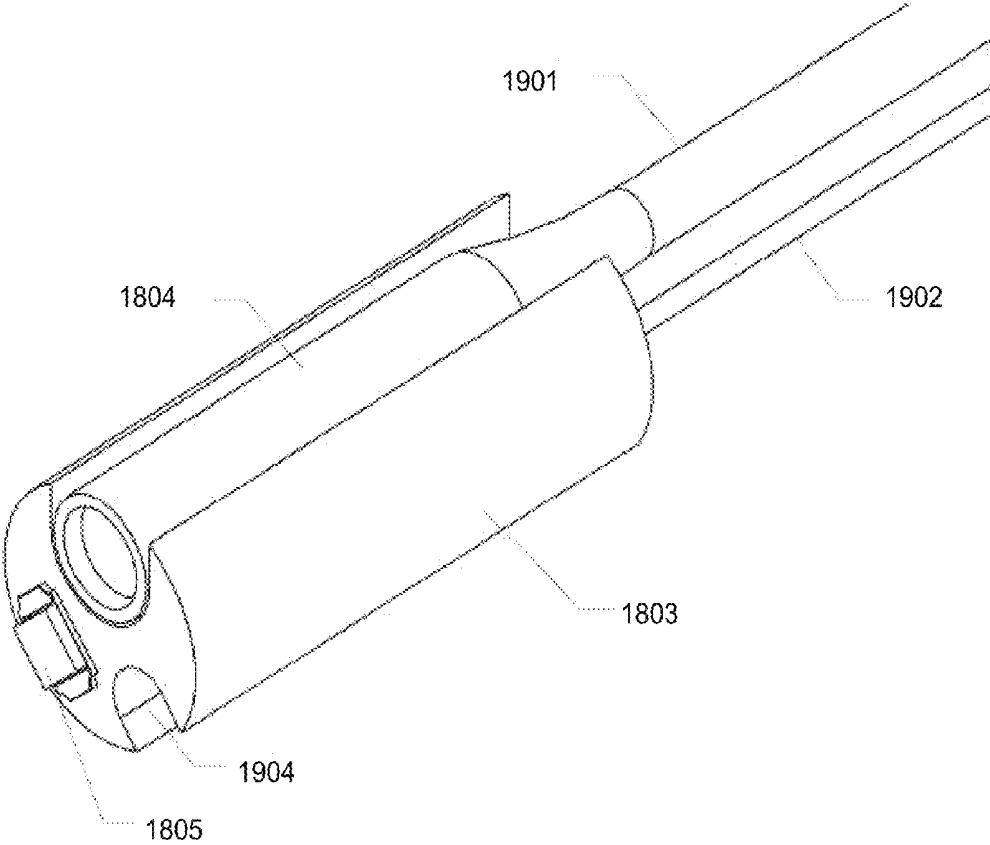


Figure 19

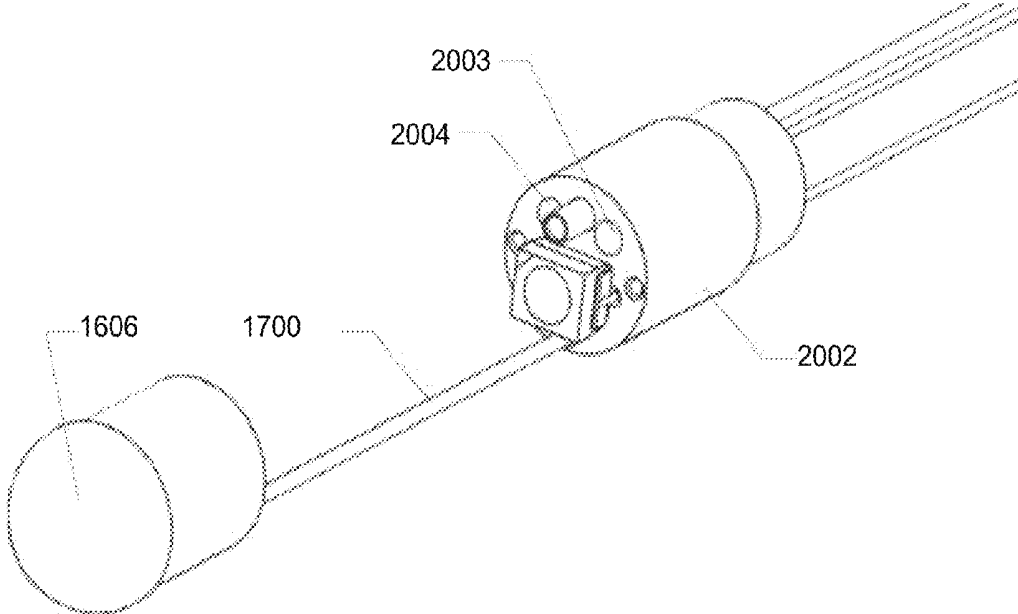


Figure 20

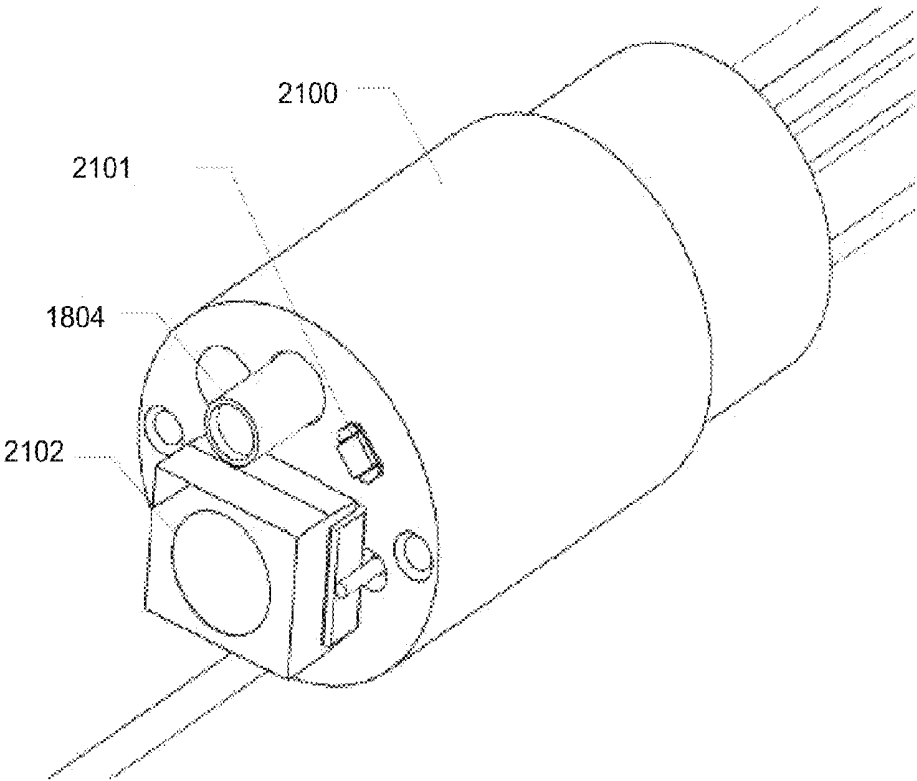


Figure 21

## SYSTEMS AND METHODS FOR VISUALIZING ABLATED TISSUE

### RELATED APPLICATIONS

This application is a continuation-in-part of U.S. application Ser. No. 13/624,899, filed on Sep. 22, 2012, and claims the benefit of and priority to U.S. Provisional Application Ser. No. 61/537,798, filed on Sep. 22, 2011, and the entirety of these applications are hereby incorporated herein by reference.

### STATEMENT OF GOVERNMENT SUPPORT

This invention was made with Government support under Grant/Contract No. R01 HL095828 awarded by the National Institutes of Health. The Government has certain rights in this invention.

### FIELD

The embodiments disclosed herein relate to methods and systems for ablation and visualization of tissue.

### BACKGROUND

Exemplary embodiments are directed to techniques used during the treatment of Atrial Fibrillation (AF). Atrial fibrillation is the most common sustained arrhythmia, which currently affects two million Americans. Atrial fibrillation is associated with increased mortality, morbidity and an impaired quality of life, and is an independent risk factor for stroke. The substantial lifetime risk of developing atrial fibrillation underscores the public health burden of the disease, which in the United States alone amounts to an annual treatment cost exceeding \$7 billion.

Eighty-five percent of episodes in patients with atrial fibrillation are known to be triggered by focal electrical activity originating from within muscle sleeves that extend into the Pulmonary Veins (PV). Atrial fibrillation may also be triggered by focal activity within the superior vena cava or other atrial structures. These focal triggers can cause atrial tachycardia that is driven by reentrant electrical activity and rotors, which may then fragment into a multitude of electrical wavelets that are characteristic of atrial fibrillation. Prolonged atrial fibrillation can cause functional alterations in membrane ion channels as well as alterations in ion channel expression. These changes further perpetuate atrial fibrillation.

Radiofrequency (RF) ablation is an effective therapy for treating atrial and ventricular rhythm disturbances. Nearly 100,000 RF ablation procedures are performed annually in the United States to treat cardiac arrhythmias. RF ablation targets the key elements of reentrant pathways and/or abnormal ectopic loci without damaging significant amounts of adjacent healthy myocardium and coronary vessels. Ablations are also done with cryo-ablation and laser guided ablation systems.

To perform an RF ablation procedure, a catheter is threaded into the heart and the tip is guided into the atria. A transseptal puncture is made to allow cross-over from the right atrium into the left atrium where the crux of the ablation is performed. The catheter then emits a pulse of high-energy RF electricity that damages atrial tissues and forms scar tissue that blocks abnormal signals. The most common RF ablation treatment of atrial fibrillation consists of placing ablation lesions in a circular fashion around the ostium of each pul-

monary vein. The lesions electrically isolate the pulmonary veins to block focal triggers from entering the left atrium. RF lesions can also be placed epicardially during minimally invasive or open heart surgery.

The extent of RF ablation lesions is not simply a function of delivered RF energy, but depends on many factors, including the contact between the catheter tip and the tissue, the thickness of the myocardium, the degree of blood flow, and the presence of fat. Currently we use surrogates to determine anatomy known as 3D mapping systems (CARTO and NAVEX), surrogates can be off by 1 or 2 cm. Current electro-anatomical mapping systems map mainly the physical location of the catheter tip but not the extent of cell injury caused by the ablations. Therefore, as of today, RF ablation lesions are created with no information regarding the physiological condition of the affected tissue. This is problematic considering that gaps of excitable tissue between ablation lesions are directly related to arrhythmia recurrences. Monitoring tissue injury produced by ablation in real time remains a major limitation of current ablation approaches.

To resolve the problem of incomplete lesions, two main strategies have been proposed. The first is to improve ablation devices, which includes the development of multi-polar and linear catheters, balloon-based technologies using lasers and high-intensity focused ultrasound, as well as pressure-sensor equipped RF catheters.

The second strategy is to visualize RF ablation lesions during the ablation procedure. Such visualization can be based upon acute changes in the chemical and/or physical properties of the damaged tissue. Specifically, the current visualization proposals require the use of a dye and include magnetic resonance imaging (MRI), coherence tomography (CT) and spectroscopy.

All these strategies use surrogates to predict the areas of the gaps and none has a real time direct visualization technique as we have designed. Despite all the current technology, pulmonary vein reconnections occur in 94% of patients after the first procedure. Atrial fibrillation recurrences after ablation procedures are 80-90% of the time due to pulmonary vein reconnection at the sites of gaps.

### SUMMARY

Systems and methods for visualizing ablated tissue are disclosed herein.

According to some aspects illustrated herein, there is provided a system for imaging tissue that includes a catheter having a distal end and a proximal end; an inflatable balloon disposed about the distal end of the catheter; and an optical housing extending from the distal end of the catheter into the balloon, the optical housing being configured to position inside the balloon a light source for illuminating a tissue outside the balloon and a camera for imaging the illuminated tissue.

According to some aspects illustrated herein, there is provided a system for imaging tissue that includes a catheter having a distal end and a proximal end; an inflatable balloon disposed about the distal end of the catheter; and an optical housing extending from the distal end of the catheter into the balloon; a light source inside the balloon, the light source being supported by the optical housing and configured to excite native reduced form of nicotinamide adenine dinucleotide or nicotinamide adenine dinucleotide hydrogen (NADH) in a tissue; and a camera inside the balloon, the camera being supported by the optical housing and configured to image the tissue illuminated by the light source.

According to some aspects illustrated herein, there is provided a system for imaging tissue that includes a catheter having a distal end and a proximal end; an irrigation port to displace blood with a fluid about the distal end of the catheter; and an optical housing extending from the distal end of the catheter, the optical housing being configured to support a light emitting diode light source for illuminating tissue and a visualization device including a plurality of image sensors that convert an optical image into an electronic signal for imaging the illuminated tissue.

According to some aspects illustrated herein, there is provided a system for imaging tissue that includes a sheath for infusing a fluid capable of displacing blood and transmitting light; a catheter disposed within the sheath, the catheter having a distal end and a proximal end; an optical housing extending from the distal end of the catheter, the optical housing being configured to support a light emitting diode light source for illuminating tissue and a visualization device including a plurality of image sensors that converts an optical image into an electronic signal for imaging the illuminated tissue.

According to some aspects illustrated herein, there is provided a method for imaging tissue that includes advancing to a tissue a catheter comprising an inflatable balloon disposed about the distal end of the catheter and an optical housing extending from the distal end of the catheter into the balloon to position a light source and a camera inside the balloon; ablating the tissue; illuminating with the light source an area of tissue including tissue treated by ablation and surrounding tissue to excite NADH in the area of tissue; imaging with an imaging device the area of tissue to detect NADH fluorescence of the area of tissue; and producing a display of the imaged, illuminated tissue, the display illustrating ablated tissue as having less fluorescence than non-ablated tissue.

#### BRIEF DESCRIPTION OF THE DRAWINGS

The patent or application file contains at least one drawing executed in color. Copies of this patent or patent application publication with color drawing(s) will be provided by the Office upon request and payment of the necessary fee.

The presently disclosed embodiments will be further explained with reference to the attached drawings, wherein like structures are referred to by like numerals throughout the several views. The drawings shown are not necessarily to scale, with emphasis instead generally being placed upon illustrating the principles of the presently disclosed embodiments.

FIG. 1A is a block diagram of an exemplary system in accordance with the present disclosure;

FIG. 1B illustrates an embodiment of a catheter for use in an exemplary system in accordance with the present disclosure;

FIG. 1C illustrates a distal end of an embodiment of a catheter for use in an exemplary system in accordance with the present disclosure;

FIG. 1D illustrates a proximal end of an embodiment of a catheter for use in an exemplary system in accordance with the present disclosure;

FIG. 2A is a block diagram of an exemplary system in accordance with the present disclosure;

FIG. 2B illustrates an embodiment filter box for use in connection with the exemplary system shown in FIG. 2A;

FIG. 3 is a flow diagram of an exemplary method in accordance with the present disclosure;

FIG. 4A illustrates a RF ablation probe in the position to deliver a lesion onto the epicardial surface;

FIG. 4B illustrates the visual appearance of a typical lesion after a standard RF ablation protocol performed in a blood-free rat heart;

FIG. 4C illustrates the appearance of two distinct RF ablation lesions in a blood-free heart, as revealed by fNADH imaging;

FIG. 4D illustrates the appearance of the same two RF ablation lesions after TTC staining with vital TTC dye (white tissue—necrotic, red—viable);

FIG. 4E illustrates transverse slicing through TTC-stained heart showing depth of two lesions placed on opposite epicardial surfaces using two different power settings;

FIG. 5A illustrates lesion stability over time as seen on fNADH-sensitive channel;

FIG. 5B illustrates an image of radiofrequency ablation lesion on the epicardial surface of an excised rat heart 2 months after survival surgery as seen on fNADH-sensitive channel;

FIG. 6A, FIG. 6B and FIG. 6C illustrate comparison between the sizes of the RF lesions as they are seen on fNADH-sensitive channel and after TTC staining;

FIG. 7A, FIG. 7B and FIG. 7C illustrate occurrence of reentry between two RF lesions based on data from dual imaging of epicardial electrical activity using voltage sensitive dye and fNADH. Reentry formation occurs as electrical waves propagate through narrow isthmus between two RF lesions;

FIG. 8A, FIG. 8B, FIG. 8C and FIG. 8D illustrate profiles of fNADH and electrical activity across the isthmus between two RF lesions;

FIG. 9A, FIG. 9B, FIG. 9C and FIG. 9D illustrate RH237 retention within the ablation areas;

FIG. 10A, FIG. 10B, FIG. 10C and FIG. 10D illustrate RH237 retention after RF ablation procedure as it compares to NADH fluorescence. FIGS. 10B&C show RF ablations done in rat hearts, FIG 10D—a rabbit heart;

FIGS. 11A-11D illustrate visualization of RF ablation lesions in blood-perfused open-chest animals. As shown in FIG. 11D the ablated lesion is identified by lack of fluorescence which gives the tissue a dark appearance (center portion of the figure) whereas the ischemic or injured tissue becomes brighter as illustrated by the halo type appearance;

FIG. 12 is an image of an ablation lesion on the endocardial surface of blood perfused canine left atrial tissue near pulmonary veins;

FIG. 13 is an image of an ablation lesion on epicardial surface of blood-free rat hart after cryo-ablation;

FIG. 14 illustrates fNADH lesion in rat blood-perfused liver that has been acutely ablated using radiofrequency ablation; and

FIG. 15 is a 2D image on the right of a standard catheter and reconstruction into 3D integrated into 3D mapping system. A computer system and program can be used to convert the acquired 2D image of NADH fluorescence into a 3D image superimposed on the atrial anatomy as displayed.

FIG. 16 is a view of an embodiment of the balloon catheter assembly of the present disclosure.

FIG. 17 is a view of an embodiment of the balloon catheter assembly of the present disclosure with balloon hidden.

FIG. 18 is a view of an embodiment optical housing inserted into an embodiment catheter of the present disclosure.

FIG. 19, FIG. 20 and FIG. 21 illustrate various non-limiting embodiments of an optical housing of the present disclosure.

While the above-identified drawings set forth presently disclosed embodiments, other embodiments are also contem-

plated, as noted in the discussion. This disclosure presents illustrative embodiments by way of representation and not limitation. Numerous other modifications and embodiments can be devised by those skilled in the art which fall within the scope and spirit of the principles of the presently disclosed embodiments.

#### DETAILED DESCRIPTION

Exemplary embodiments of the present disclosure are directed to systems and methods of visualizing RF ablation lesions during an ablation procedure. Systems and methods for treating Atrial Fibrillation (AF) are also provided.

Systems, catheter and methods for treating Atrial Fibrillation (AF) are provided. The fluorescence of endogenous NADH (fNADH) in heart tissue is imaged to identify ablated and unablated areas using a balloon guided catheter equipped with UV illumination source and UV capable fiber, a fluorescence capable camera or imaging bundle and optical band pass filter to detect NADH fluorescence. Gaps between ablated areas can be identified using the fNADH imaging and the gaps can then be ablated. The imaging can be performed during the ablation procedure and does not require additional chemicals, such as contrast agents, tracers or dyes.

In some embodiments, the systems of the present disclosure can be utilized to illuminate tissue using ultra-violet light and the fluorescence of endogenous NADH (fNADH) can be imaged to identify ablated and unablated areas. The provision of ultra-violet light and imaging of the fNADH of the tissue can be achieved using, for example, a dual UV excitation/emission fiber-optic waveguide located at the tip of the catheter. The methods and systems of the present disclosure do not require the addition of dyes and stains. Moreover, the methods and systems of the present disclosure allow imaging during the ablation procedure so as to not require an additional invasive ablation procedure following the initial procedure. Utilizing the methods and systems of the present disclosure results in having a completely dark area at the sites of complete ablation due to lack of fluorescence which may enhance the ability to detect the ablated areas by providing marked contrast to the healthy tissue and even more contrast at the border zone between ablated and healthy tissue. This border area is the edematous and ischemic tissue in which NADH fluorescence becomes bright white upon imaging. The border zone creates a halo appearance around the ablated central tissue.

In accordance with exemplary embodiments of the present disclosure, ablated tissue and tissue surrounding the ablated tissue is imaged using the fluorescence of endogenous NADH (fNADH) using low-intensity ultraviolet light illumination. NADH is a coenzyme that is present within intact cells and is particularly abundant in cardiac muscle cells. Once NADH is released from mitochondria of damaged cells and/or converted to its oxidized NAD<sup>+</sup> form, cardiomyocyte fNADH markedly declines. This reveals the ablation-induced muscle injury to highlight gaps that indicate incomplete epicardial lesions.

Ablations are currently performed without meaningful real-time information regarding the physiology of the ablated tissue. Electrical isolation of focal sources is the only indicator of ablation efficiency. There are two main limitations of this approach. The first is that the extent of the lesions cannot be measured during the procedure. The second is that the specific cause of electrical isolation cannot be determined. For example, electrical isolation may result from cardiac muscle damage, but also from functional changes in reversibly injured cells, as well as by temporary edema. In the case

of edema, it may subside after a few weeks, potentially restoring abnormal electrical conduction. The fNADH imaging of the present disclosure reveals irreversible cardiac muscle injury without contrast agents, tracers or dyes. Lesions examined via fNADH imaging are seen immediately after delivering RF energy and they are stable for several hours. Therefore, visualization can be done concordantly with ablation or after multiple lesions have been placed.

There is no contradiction between the increase in NADH fluorescence during ischemic injury used in the present disclosure as opposed to a decrease upon thermal damage due to the following reasons. About thirty percent of cardiomyocyte volume is comprised of mitochondria, which contain a large amount of NADH. Accordingly, changes in the level of fNADH from myocytes can be measured with relative ease. When the sarcolemma and mitochondrial membranes are disrupted by heat, NADH is lost and fNADH levels immediately fall. During hypoxia and/or ischemia, cellular integrity is preserved but oxygen availability is reduced. Oxygen serves as a final electron acceptor in the mitochondrial electron chain and its decline leads to NADH accumulation. Thus, ischemia causes an increase in fNADH in a time dependent manner. For example, if coronary perfusion is temporarily disrupted during ablation, patches of ischemic or injured tissue with elevated fNADH levels may be observed adjacent to the darker circular fNADH lesions after ablation, which can be seen in FIG. 4C.

Monitoring endogenous fNADH can be done without additional tracers or contrast agents. Since changes in fluorescence reflect acute biochemical changes, lesions are seen almost immediately. Although imaging modalities such as MRI, C-arm CT, and contrast echocardiography are excellent tools in detecting parameters resulting from heat induced biophysical changes, contrast agents are required to visualize changes in real time. Additionally, while MRI and C-arm CT provide high spatial resolution, it could take up to 30 minutes to visualize cell necrosis. Echocardiography is faster but suffers from low spatial resolution and limited field of view. Other modalities based on physical tissue changes including alteration in tissue elasticity, impedance, or absorption have also been explored. While such strategies provide real-time feedback and may predict lesion size and depth, they also require significant data processing and don't provide direct visualization of the ablated region. It should, however, be noted that these well-known imaging methods may be used in combination with the methods of the present disclosure.

Today a majority of ablation procedures are endocardial but approximately 10 to 20% could be applied to the epicardium. Epicardial substrates are frequently observed for VT, including >20% of postinfarct VTs, and >30% of VTs from nonischemic cardiomyopathy, particularly for Chagas disease. Ablation of these epicardial substrates may use a percutaneous approach that involves the subxiphoid placement of sheaths into an intact, closed pericardial space. fNADH imaging is particularly useful for these procedures. Conventional endoscopes equipped with UV-compatible optics and light sensitive image capture devices would be suitable for this purpose. Air insufflation through the endoscope could be used to expand the pericardial space for adequate visualization of ablation sites. In a clinical setting, insufflation with carbon dioxide rather than air would likely reduce the risk of air embolization. fNADH imaging might also be used for endocardial procedures if blood is displaced using inflatable balloons in front of an endoscope.

The systems and methods of the present disclosure enable the user to monitor myocardial damage while performing an ablation. By doing so, clinical cardiac electrophysiologists

may be able to shorten the time and improve the efficiency of ablation, minimize unnecessary tissue injury that may cause post ablation complications, and decrease post-ablation recurrence of arrhythmias and the need for follow-up ablations. fNADH imaging may also be useful for mechanistic studies of tissue injury near the ablation sites and for assessment of drugs that may alter electrical propagation between inter-lesion gaps.

The use of fNADH imaging allows visualizing of ablation lesions and gaps between lesions in both blood-free and blood-perfused rat and rabbit hearts. Optical action potentials and the endogenous fluorescence of NADH can be imaged to study changes in electrical activity and tissue viability around ablation lesions. The fNADH imaging can be accomplished during ablation procedures using a dual UV excitation/emission fiber-optic waveguide located at the tip of a catheter. Such a waveguide system could interface with a 3D mapping system to provide a detailed map of cardiac muscle viability near the catheter.

FIG. 1A is a block diagram of an exemplary system in accordance with the present disclosure. The system includes an inflatable balloon catheter **105** coupled to external equipment **125**. In some embodiments, the catheter **105** includes an ablation device **110**, illumination device **115** and an imaging device **120**. In some embodiments, the illumination device **115** and an imaging device **120** may utilize a fiber-optic waveguide to pass the light to and from the treated tissue.

In some embodiments, the methods and systems of the present disclosure may be used in connection with ablation procedures to monitor in real time when the complete ablation of desired tissue has been achieved. Ablation is a process that uses energy, heat or extreme cold (cryo) to destroy or damage tissue (ablation). For example, RF ablation relies on heat generated from the high frequency alternating current to ablate tissue. Cryoablation is used in a variety of clinical applications using hollow tubes or needles (cryoprobes) through which cooled, thermally conductive, fluids are circulated, to destroy the tissue by freezing the tissue. The systems and methods of the present disclosure may be utilized in connection with various types of tissue ablation, including, but not limited to, RF ablation, cryoablation, acoustic energy ablation, electromagnetic energy ablation, microwave energy ablation, ultrasound ablation, chemical ablation, laser ablation, thermal ablation, electrical ablation or other types of thermal or non-thermal energy ablations. To that end, in some embodiments, the ablation device **110** may be advanced to a tissue in need of ablation to ablate the tissue. In some embodiments, the ablation device **110** has an energy source selected from the group consisting of radiofrequency energy, microwave energy, electrical energy, electromagnetic energy, cryoenergy, laser energy, ultrasound energy, acoustic energy, chemical energy, and thermal energy.

The external equipment **125** includes a light source **130**, which provides ultra-violet light to illumination device **115**, a camera **135** and a display **140**. In some embodiments, the camera **135** can be a CCD camera that has a high quantum efficiency for wavelengths corresponding to NADH fluorescence (i.e., 80% quantum efficiency at 460 nm), such as an Andor Ixon DV860 camera. In some embodiments, the camera **135** may be equipped with a 460/25 nm filter **135** (i.e., a filter to pass ultra-violet light while blocking light outside of the ultra-violet spectrum).

In reference to FIG. 1B, in some embodiments, the catheter **105** is a multi-lumen catheter having a proximal end **220** and a distal end **221**. The catheter **105** includes a balloon **222** disposed about the distal end **221** of the catheter **105**. The balloon **222** may be made of a UV transparent material, such

as, for example, a UV transparent fluoropolymer. In some embodiments, the balloon **222** may have a thickness of 50  $\mu\text{m}$  and refractive index of 1.31. The balloon **222** may be either a complaint balloon or a non-complaint balloon.

The balloon **222** may be round, flat, cylindrical, oval, rectangular or another shape depending on the anatomy to be treated using the catheter **105**. The balloon **222** may displace blood at the site of fluorescence imaging in order to afford an optically uncluttered view. Since blood possesses fluorescent properties mostly due to the hemoglobin, imaging through this medium would saturate the emission pathway. The balloon may be inflated with a gas or a liquid. For example, carbon dioxide, which has a low refractive index of about 1.00045, may be used to inflate the balloon. Also, in the event of a balloon breach in vivo, CO<sub>2</sub> exposure in the short term would not pose any immediate mortal danger due to the abundant partial pressure of N<sub>2</sub> gas. Suitable liquids include, but are not limited to, water, saline, blood or another similar liquid. The catheter **105** may include an inflation/deflation lumen **225** for inflating and deflating the balloon **222**. Two separate lumens may be provided in some embodiments for inflating and deflating the balloon **222**.

In addition to the inflation/deflation lumen **225**, the catheter **105** may further include an ablation lumen **223** for advancing an ablation device **110**, an imaging lumen **224** for advancing an imaging device **120**, and an illumination lumen **226** for advancing an illumination device **115**. It should of course be understood that the catheter **105** may include additional lumens or some lumens may serve multiple functions. For example, in some embodiments, a single fiber optic bundle may be employed to pass the light from a light source **130** to the tissue to illuminate the tissue and to pass the light reflected by the tissue to a camera **135**.

In reference to FIG. 1C, an embodiment of the distal tip **221** of the catheter **105** without the balloon **222** is illustrated. The ablation lumen **223** allows an ablation device **110** to be passed to or past the distal end **221** of the catheter **105** for ablation of desired tissue. The inflation/deflation lumen **225** enables the user to inflate and deflate the balloon **222** to aid in fluorescence imaging. The imaging lumen **224** allows an imaging device **120** to be advanced into the balloon for imaging the ablated tissue, which can be illuminated by an illumination device **105** advanced through the illumination lumen **226**. It should of course be understood that, to the extent desired, the position of various lumens **223-226** in relation to one another may be varied.

In reference to FIG. 1D, an embodiment of the proximal tip **220** is illustrated. In some embodiments, an ablation port **233** in communication with the ablation lumen **223** may be provided for introducing an ablation device **110** into the catheter **105**. Another port **235** may be provided in communication with the inflation lumen **225a** and deflation lumen **225b** for operating the balloon **222**. In some embodiments, the proximal end **220** includes an outlet **237** in communication with the imaging lumen **224** and illumination lumen **226** to introduce an imaging device **120** and an illumination device **110** into the catheter **105**. The catheter **105** may also be provided with a connector **240** for connecting the catheter **105** to one or more external equipment **125**.

Referring back to FIG. 1A, the external equipment **125** may include a camera **135**. In some embodiments, the camera **135** may be a CCD (charge-coupled device) camera. In some embodiments, the camera **135** may be selected so it is capable of collecting as many photons as possible and that contributes minimal noise to the image. Usually for fluorescence imaging of live cells, CCD cameras should have a quantum efficiency at about 460 nm of at least between 50-70%, indicating that

30-50% of photons will be disregarded. In some embodiments, the camera **135** has quantum efficiency at 460 of about 90%. The camera **135** may have a sample rate of 80 KHz. In some embodiments, the camera **135** may have a readout noise of  $8 e^-$  (electrons) or less. In some embodiments, the camera **135** has a minimum readout noise of  $3e^-$ .

The external equipment **125** may further include a light source **130**, such as a UV LED emitter. The light source is utilized to illuminate tissue via an imaging device **120**, which may comprise a fiber optic light guide and may be advanced through the imaging lumen **224** to the distal tip **221** of the catheter **105** to capture tissue images. In some embodiments, the fiber optic light guide can act as an illumination device **115** to pass the light at excitation wavelength from a light source **130** to the tissue for illuminating tissue to be visualized. The fiber optic light guide can also act to pass the light reflected by the tissue back to the camera **135**. In some embodiments, separate fiber optics networks can be used for illumination and imaging that is, in some embodiments an illumination device **115** may be independent of the imaging device **120**. In some embodiments, a fiberscope can be used as an imaging device, illumination device, or both.

Once the images of illuminated tissue are captured by the CCD, these images can be transmitted to a display **140** to be displayed to the user in real time. The images can be analyzed by using software to obtain real-time details (e.g. intensity or radiated energy in a specific site of the image) to help the user to determine whether further intervention is necessary or desirable.

In reference to FIG. 2A, in some embodiments, the system of the present disclosure may include a filter box **145** positioned between the catheter system **105** and the external equipment **125**, such as the camera **135** and light source **130**. The filter box **145** may include a dichroic mirror **146** for reflecting light from the light source **130** to be propagated by the illumination device **115**. The dichroic mirror **146** may be placed at a  $45^\circ$  incidence angle to light, creating a stop band of reflected light and a pass band of transmitted light. Light from the light source **130** is reflected by  $90^\circ$  in the direction of the specimen. Concurrently, in the same orientation, light emanating from the specimen is passed through the mirror. In some embodiments, a longpass dichroic mirror with a cutoff (50%) wavelength of 425 nm may be used as it has an approximate reflection band of more than 80% between 355 nm and 410 nm and a transmission band of more than 90% between 440 nm and 700 nm. Of course it should be understood that other optical devices may be used to pass light to and from the tissue to be visualized.

The filter box **145** may also include an emission filter **147** to filter out light that may contribute as some sort of noise or unwanted feature. In some embodiments, based on the NADH fluorescence, the filter **147** may be a center wavelength of 460 nm with a 50-nm bandwidth (i.e.  $460 \pm 25$  nm). The filter box **145** may further include an excitation filter for selection of the excitation wavelength of light from the light source **130**.

In reference to FIG. 2B, an embodiment filter box **145** includes a camera port **400** with an emission filter **401** held in a filter holder **402** positioned in front of the camera port **400**. The filter box **145** further includes an excitation filter **403** held in a filter holder **404**, which may be positioned either at a light source port or a catheter port. The excitation filter **403** is positioned at a catheter port **405**. A dichroic mirror **405** is inserted into a mirror slot **406** and is positioned at about a 45 degree angle to a port for attaching the light source **130** to the filter box **145**.

In reference to FIG. 3, operation of the systems of the present disclosure is illustrated. Initially, catheter **105** is inserted into the area affected by the atrial fibrillation, such as the pulmonary vein/left atrial junction (step **150**). Blood is removed from the visual field. For atrial fibrillation ablation a transparent balloon surrounding the fiber optic waveguide would be used to displace the blood at the pulmonary vein/left atrial junction. The affected area is illuminated by ultra-violet light from source **130** and illumination device **115** (step **155**) and tissue in the illuminated area is ablated using ablation device **110** (step **160**). Either point-to-point RF ablation or cryoablation or laser or other known ablation procedures may be employed using the systems of the present disclosure. Ablation proceeds by threading the tip through the central lumen of the catheter. After the procedure, the ablation tip may be retracted.

The illuminated area is imaged by the combination of imaging device **120** and camera **135** (step **165**). The methods of the present disclosure rely on imaging of the fluorescence emission of NADH, which is a reduced form of nicotinamide adenine dinucleotide (NAD+). NAD+ is a coenzyme that plays important roles in the aerobic metabolic redox reactions of all living cells. It acts as an oxidizing agent by accepting electrons from citric acid cycle (tricarboxylic acid cycle), which occurs in the mitochondrion. By this process, NAD+ is thus reduced to NADH. NADH and NAD+ are most abundant in the respiratory unit of the cell, the mitochondria, but are also present in the cytoplasm. NADH is an electron and proton donor in mitochondria to regulate the metabolism of the cell and to participate in many biological processes including DNA repair and transcription.

By measuring the UV-induced fluorescence of tissue, it is possible to learn about the biochemical state of the tissue. NADH fluorescence has been studied for its use in monitoring cell metabolic activities and cell death. Several studies in vitro and in vivo investigated the potential of using NADH fluorescence intensity as an intrinsic biomarker of cell death (either apoptosis or necrosis) monitoring. Once NADH is released from the mitochondria of damaged cells or converted to its oxidized form (NAD+), its fluorescence markedly declines, thus making it very useful in the differentiation of a healthy tissue from a damaged tissue. NADH can accumulate in the cell during ischemic states when oxygen is not available, increasing the fluorescent intensity. However, NADH presence disappears all together in the case of a dead cell. The following table summarizes the different states of relative intensity due to NADH fluorescence:

Cellular State	NADH Presence	Relative Changes of Auto-fluorescence intensity
Metabolically Active	Normal	Baseline
Metabolically Active but Impaired (Ischemia)	Increased to Hypoxia	Increased
Metabolically Inactive (Necrotic)	None	Full Attenuation

While both NAD+ and NADH absorb UV light quite readily, NADH is autofluorescent in response to UV excitation whereas NAD+ is not. NADH has a UV excitation peak of about 350-360 nm and an emission peak of about 460 nm. In some embodiments, the methods of the present disclosure may employ excitation wavelengths between about 335 to about 380 nm. With the proper instrumentation, it is thus possible to image the emission wavelengths as a real-time measure of hypoxia as well as necrotic tissue within a region

of interest. Furthermore, a relative metric can be realized with a grayscale rendering proportionate to NADH fluorescence.

Under hypoxic conditions, the oxygen levels decline. The subsequent fNADH emission signal may increase in intensity indicating an excess of mitochondrial NADH. If hypoxia is left unchecked, full attenuation of the signal will ultimately occur as the affected cells along with their mitochondria die. High contrast in NADH levels may be used to identify the perimeter of terminally damaged ablated tissue.

To initiate fluorescence imaging, the operator may deploy the balloon, which is installed around the distal portion of the catheter. Next, NADH is excited by the UV light from the light source **130**. In some embodiments with a filter box, first the excitation light from the light source hits the dichromatic mirror (or dichroic beam splitter) positioned within the filter box **145**. Then the excitation light is reflected by the dichromatic mirror toward the specimen via the fiber optic. In some embodiments, the mirror may be positioned at a 45° angle relative to the excitation light and the excitation light may be reflected 90°. In some embodiments, the methods of the present disclosure may employ excitation wavelengths between about 335 to about 380 nm.

NADH in the tissue specimen absorbs the excitation wavelengths of light and emit longer wavelengths of light. The emission light may be collected and passed back through the dichromatic mirror **146**. This mirror **146** may therefore be designed to reflect the excitation wavelengths, but transmit the emission wavelengths. The reflection of the excitation wavelengths is not 100%, so a small amount of this light passes through the dichromatic mirror **146**. Likewise, additional light with a different wavelength could pass through, and thus an emission filter may be employed in connection with the camera **135**. The emission filter may be selected for the emission wavelengths of light expected from the fluorophore such as NADH.

Once the light is filtered, the light may be collected by the camera **135**, and a display of the imaged illuminated area is produced on display **140** (step **170**), which is used to identify the ablated and unablated tissue in the imaged area using NADH fluorescence (step **175**). The process then repeats by returning to the ablation step, if necessary to ablate additional tissue. It should be recognized that although FIG. **3** illustrates the steps being performed sequentially, many of the steps will be performed simultaneously or nearly simultaneously. Thus, for example, the ablation, imaging and display can occur at the same time, and the identification of the ablated and unablated tissue can occur while ablating the tissue.

The methods, systems and devices disclosed herein can be used for a variety of therapeutic procedures. Exemplary procedures in which the methods, systems and devices disclosed herein can be utilized include, but not limited to, for diagnostic and therapeutic procedures in the heart, for treating arrhythmias, such as, for example, supraventricular arrhythmias and ventricular arrhythmias, for treating atrial fibrillation, and pulmonary vein mapping and ablation. The ablated tissue may be cardiac muscle, but the methods disclosed herein should have the same effect on skeletal muscle, liver, kidney, and other tissues with significant presence of NADH-rich mitochondria.

In reference to FIG. **16**, a catheter **1601** for use in connection with systems and methods of the present disclosure includes one or more lumens extending therethrough and an expandable balloon **1603** disposed about the distal end of the catheter **1601**. In some embodiments, the balloon **1603** may be attached at its proximal tip **1604** to the distal end of the body of the catheter **1601** and attached at its distal tip **1605** to a catheter tip **1606**, which may be connected to the catheter

**1601** by a tube or lumen as described below. The balloon **1603** may be made from an optically transparent material and may be used to move blood out of the way for the optical components during fluorescence imaging. The balloon **1603** can be made of many different materials and shapes that would best conform to various anatomic structures. The balloons may be constructed of a soft material, such as silicone, and be compliant to the anatomy. Alternatively, the balloon may be constructed of a stronger material, such as polyurethane, and be less compliant. As illustrated in FIG. **16**, the balloon **1603** may have a conical shape designed for insertion into the ostium of the pulmonary veins. Other shapes of a more circular nature may be better suited for visualizing other cardiac anatomical sights for ablation therapy, including, by way of a non-limiting example, accessory pathways, ventricular wall sites, atrial wall sights, or atrio-ventricular nodal sights.

The catheter **1601** may be utilized for tissue ablation, including, but not limited to, RF ablation, cryoablation, acoustic energy ablation, electromagnetic energy ablation, microwave energy ablation, ultrasound ablation, chemical ablation, laser ablation, thermal ablation, electrical ablation or other types of thermal or non-thermal energy ablations. To that end, in some embodiments, the catheter **1601** may be advanced to a tissue in need of ablation and an ablation member capable of performing one more ablation methods can be passed through the catheter **1601** to ablate the tissue. In some embodiments, the ablation member has an energy source selected from the group consisting of radiofrequency energy, microwave energy, electrical energy, electromagnetic energy, cryoenergy, laser energy, ultrasound energy, acoustic energy, chemical energy, and thermal energy.

In some embodiments, the catheter tip **1606** may be configured to act as an electrode either for diagnostic purposes, such as electrogram sensing, or for therapeutic purposes, such as for emitting ablation energy. In some embodiments where ablation energy is required of the catheter, the tip **1606** of the catheter **1601** could serve as an ablation electrode or ablation element. In the embodiments where RF energy is implemented, the wiring to couple the tip to the RF energy source (external to the catheter) can be passed through a lumen of the catheter **1601**. The tip **1606** may include a port **1607** in communication with the one or more lumens of the catheter **1601**. In this manner, a guide wire or other surgical instruments, such as, for example, an RF electrode, may be advanced out of the catheter **1601** past the tip **1606**. The tip **1606** can be made of any biocompatible material. In some embodiments, if the tip is configured to act as an electrode, the tip **1606** can be made of metal, including, but not limited to, platinum, platinumized iridium, stainless steel, or titanium. The tip **1606** may also be made of a biocompatible plastic, including, but not limited to, silicone, peek, polyurethane.

In reference to FIG. **17**, in some embodiments, the catheter tip **1606** may be connected to the main body of the catheter **1601** by a guide wire tube **1700** extend past distal tip of the main body of the catheter **1601**. The guide wire tube **1700** may include one or more lumens in communication with one or more lumens of the catheter **1601** for advancing a guide wire, ablation member or other surgical instruments past the distal tip of the catheter **1601**. The inner lumens of the guide wire tube **1700** may also be in communication with the port **1607** of the catheter tip **1606** for advancing surgical instruments through the guide wire tube **1700** to or past the catheter tip **1606**.

In some embodiments, the guide wire tube **1700** may act to provide structural support to the balloon **1603**, especially when the balloon **1603** is in a deflated state during the advancement of the catheter **1601** to the treatment site. In

some embodiments, the guide wire tube **1700** may be semi-rigid to provide structural support to the balloon **1603**. In some embodiments, the guide wire tube **1700** may be an integral lumen of the catheter **1601**. In some embodiments, the guide wire tube **1700** is separate from the catheter **1601** and may be removably inserted into the distal tip of the catheter **1601**. In some embodiments, the guide wire tube **1700** may be slidably disposed within the catheter **1601**, so that the guide wire tube **1700** may be moved in relation to the catheter **1601** to adjust the shape of the balloon **1603** to aid in advancement or withdrawal of the catheter **1601** from the patient's body. For example, the guide wire tube **1700** may be advanced to stretch a collapsed balloon for easier withdrawal out of the patient's body. In such a state, the balloon would be more behaved and less likely to get caught on an introducer sheath when being removed. The guide wire tube may be made of any material. In some embodiments, the guide wire tube **1700** may be made from a shape memory material, such as Nitinol.

In reference to FIG. **17** in combination with FIG. **16**, the catheter **1601** may include a neck down surface **1701** where the proximal end **1604** of the balloon **1603** may be attached to the catheter **1601** without increasing the outer diameter of the combined device.

In reference to FIG. **18**, an optical housing **1803** may be disposed at the distal end of the catheter **1601** for positioning optical elements, such as a camera **1804** and a light source **1805**, inside the balloon **1603**. The optical housing **1803** enables positioning of the camera **1804** and light source **1805** within the balloon, thus eliminating the need for an external light source. Moreover, by putting the light sources within the balloon, wider angles of illumination may be achieved than when using a fiber bundle. As is shown in FIG. **18**, the optical housing **1803** can extend from the catheter into the balloon such that the light source and the camera are completely contained within the balloon to ensure that the catheter does not interfere with the field of view of the light source or the camera. As shown in FIG. **18**, that the light source and the camera are internal to the balloon and do not extend outside the balloon. In some embodiments, the housing **1803** may position the optical elements in a fixed relation to one another. In some embodiments, the camera **1804** and the light source **1805** are flush with each other so that neither component "blocks" the function of the other. Being flush assures that the camera **1804** will not block illumination nor will the light source **1805** show up in the camera image. In some embodiments, the position of the components may be altered to avoid interference of one optical component with the other one.

The camera **1804** may be any image sensor that can convert an optical image into an electronic signal. In some embodiments, the camera is a miniature CMOS image sensor with a lens and with or without a filter to choose a specific wavelength or set of wavelengths to record. In some embodiments, the camera is a CCD camera or other image sensors that can convert an optical image into an electronic signal. The camera may transmit its signal via wires to external image processor and video terminal for the physician to see. In some embodiments, the camera may have wireless communication capabilities for communication with external devices. The light source **1805** may be a light emitting diode (LED) of suitable wavelength. In some embodiments, the LED will have a wavelength in the UV range to cause the NADH fluorescence. In some embodiments, different wavelengths including white light for multicolor illumination are possible by choosing the LED of the appropriate wavelength. By way of a non-limiting example, suitable LEDs for UV applications would include those with wavelengths of 300 nm to 400 nm, while suitable

LEDs for visible or white light applications would include those with color temperature ranges from 2000K to 8000K.

As shown in FIG. **18**, the housing **1803** may be inserted into the distal end of the catheter **1601**. In some embodiments, the outer diameter of the housing **1803** may be smaller than the inner diameter of the catheter **1601** such that a gap **1802** may be formed between the inner wall of the catheter **1601** and the housing **1803**. In some embodiments, the balloon **1603** may be deflated or inflated through the gap **1802**. It should of course be understood that a separate lumen may be provided for operating the balloon **1603**.

In some embodiments, because the outer diameter of the optical housing **1803** is smaller than the inner diameter of the catheter **1601**, the housing **1803** may be moveable in relation to the catheter **1601**. In some embodiments, the housing **1803** may be freely rotated in relation to the catheter **1601** and, thus the balloon **1603**. In some embodiments, the optical housing **1803** may be translated longitudinally in relation to the balloon catheter **1601** to obtain a desired view point for the camera or illumination position for the light source. A lock may be provided to lock the optical housing **1803** in a desired position.

FIG. **19** is a view of the housing **1803** outside the catheter **1601**, showing a wire bundle **1901** of the camera **1804** and a wire bundle **1902** for the light source **1805**. These wire bundles may run the entire length of the catheter back to the handle (not shown) where they can make electrical connections to the remainder of the imaging system, such as a power source or a display. It should be noted however that, in some embodiments, the camera may have wireless communication capabilities for wireless communication with external devices

The housing **1803** also includes a channel **1904** for accepting a guide wire tube **1700** to facilitate communication between the guide wire tube **1700** and the catheter **1601**.

The catheters of the present disclosure may be used in minimally-invasive procedures as well as in conventional surgical procedures, i.e. open procedures. In some embodiments, the catheters of the present disclosure may be configured for endovascular approach. In some embodiments, the catheters of the present disclosure may be configured for non-endovascular approach. In some embodiments, the systems of the present disclosure may be surgical systems or device used in surgical procedures via either an open incision or percutaneous introduction into the tissue rather than via an endovascular route. In some embodiments, the systems and devices of the present disclosure may be either handheld or a part of a robotically controlled system. In some embodiments, the systems or devices of the present disclosure may be configured for handling by a robotic system.

In some embodiments, the size of the components may be varied depending on the particular procedure. In some embodiments, the rigidity of the catheters of the present disclosure may be varied depending on the type of procedure, anatomy to be treated or both. In some embodiments, the rigidity may be varied by selecting more rigid components for the catheter **1601**, the guide wire tube **1700** or both.

In reference to FIG. **20**, in some embodiments, an optical housing **2002** may include multiple channels **2003**, **2004** for accommodating multiple guide wire tubes, if more rigidity is required. It should be noted that in various embodiments, some or all guide wire tubes may include inner lumens in communication with the inner lumens of the catheter **1601** and the port **1607** of the catheter tip **1606** for passing surgical instruments through such guide wire tubes. In some embodi-

ments, some or all guide wire tubes may act simply be provided for structural support, and thus may not include inner lumens.

FIG. 21 illustrates an embodiment of an optical housing 2100 configured to support multiple light sources 2101 and 2102, which may emit light of different wavelengths. Having different wavelength sources allows for different functionality within a single catheter or instrument. In some embodiments, the light source 2101 may be selected to emit UV light for fluorescence imaging, while the light source 2102 may be selected to emit white light to allow the user to see and navigate anatomical landmarks. Bundled together, the user can use the same catheter both for navigating to the ablation site to ablate tissue, and then to visualize the ablated tissue. In some embodiments, multiple sources of the same wavelength may be employed. In some embodiments, the optical housing 2100 may be configured to support two, three, four or more light sources.

It should be noted that although the optical housing 1803 is illustrated and describe as supporting a light source and camera, in some embodiments, the housing may be configured to support one or more fiber optic bundles in communication with an external camera and an external light source.

The methods, systems and devices disclosed herein can be used for a variety of therapeutic procedures. Exemplary procedures in which the methods, systems and devices disclosed herein can be utilized include, but not limited to, for diagnostic and therapeutic procedures in the heart, for treating arrhythmias, such as, for example, supraventricular arrhythmias and ventricular arrhythmias, for treating atrial fibrillation, and pulmonary vein mapping and ablation.

The presently disclosed methods can be used with two dimensional (2D) to three dimensional (3D) mapping protocols. A plurality of 2D images can be superimposed onto a 3D reconstruction image of the tissue or organs, including the heart. Many arrhythmia procedures include the use of reconstructed three dimension images of the patient's specific anatomy during the procedure. Using a variety of imaging modalities including computed tomography (CT), magnetic resonance imaging (MRI), ultrasound, and electroanatomical mapping using systems such as NAVX and CARTO. In all cases, the three dimensional anatomical images or surfaces present patient specific anatomy to help target areas of tissue to treat. In all cases, the ability to visualize the precise location where lesions are formed and the precise locations where lesions are missing, e.g., the "gaps" or breaks in the lesion set, would guide the procedure to optimize the therapeutic outcome. 2D image to 3D image mapping allows the system to superimpose, spatially register, and/or texture map single or multiple images of tissue (that may indicate presence or absence of lesions) with the specific anatomy of the patient in a three dimensional, rotatable, interactive virtual environment.

In some embodiments, the systems and methods of the present disclosure allow the registration and/or overlay of the images produced by the system onto the specific anatomy of the patient as seen using other imaging modalities such as an MRI image, computed tomography (CT) image, ultrasound image and three dimensional reconstructions thereof. In some embodiments, the systems and methods of the present disclosure may further include the registration and/or overlay of the images produced by the system onto the specific anatomy of the patient as seen using other electroanatomical mapping, anatomical reconstruction, and navigational systems such as NAVX and CARTO. The registration and overlay may be performed during the procedure in real time. Texture mapping NADH images onto reconstructed endocardial surfaces

permits visualization of the treatment site. For example, multiple NADH snapshots of lesions could create a full panoramic image of the entire pulmonary vein opening, or multiple pulmonary veins. Positioning sensors on the catheter tip could provide information that will allow the NADH images to be combined together to create a 3D reconstruction image.

While the methods and systems of the present disclosure were described in connection with a balloon catheter, the methods and systems of the present disclosure may also utilize catheters without balloons. Other means for displacing blood during fluorescence imaging may be utilized. For example, the catheter of the present disclosure may be provided with an irrigation port through which a fluid can be delivered to the distal tip of the catheter to displace blood away from the tissue being imaged. In some embodiments, the catheter may be introduced through a sheath which can infuse a clear fluid capable of displacing blood and transmitting light. It should of course be understood that, in some embodiments, the means for displacement blood may be combined. Thus, for example, a balloon catheter as described above can be provided with additional irrigation port to assist in blood displacement by the balloon.

Examples of using the systems and methods of the present disclosure are provided below. These examples are merely representative and should not be used to limit the scope of the present disclosure. A large variety of alternative designs exists for the methods and devices disclosed herein. The selected examples are therefore used mostly to demonstrate the principles of the devices and methods disclosed herein.

## EXAMPLES

### Experimental Procedures

Experiments were performed using animal hearts to compare the effectiveness of the imaging using NADH recording of the present disclosure compared to Triphenyltetrazolium chloride (TTC) staining. As will be described in more detail below, the imaging using NADH recording performed as good as TTC staining. Importantly, it was done in living tissue, did not require any additional processing time or the use of a dye to achieve the same performance.

#### Animal Procedures

Ex-vivo experiments were conducted using excised blood-free hearts of a rat (200-300 g Sprague-Dawley, n=8) and rabbit (2.5-3.5 Kg New Zealand White, n=3). The animals were heparinized and anesthetized using standard procedures. Hearts were then excised, the aorta was cannulated and Langendorff-perfused at constant pressure (50 mmHg) with oxygenated, buffered Tyrode solution at room temperature. The hearts were placed on top of a grounding pad and submerged in 37° C. Tyrode solution during ablation.

In situ experiments (n=3) were performed using anesthetized open-chest rats (200-300 g Sprague-Dawley). After an IP injection of Telazol (40 mg/kg) the hair on the chest and back were shaved, the animal was immobilized on a heated platform, and an ablation pad was placed beneath the animal. Immediately after opening chest cavity, the ablations were carried out as the exposed epicardial surface was imaged. All anesthesia and euthanasia procedures were in compliance with the institutional Animal Care and Use committee approved protocols.

#### Ablation Protocols and NADH Recordings

Radiofrequency energy was delivered using a non-cooled blazer catheter with a 4 mm tip (EP Technologies, Boston Scientific Corporation). Tip temperatures ranged between 50 to 70° C. The catheter was placed perpendicular to the epi-

cardial surface. Ablation durations varied from 15 to 60 sec with a maximum power of 50 W. The epicardial surface was illuminated with UV light (350/25 nm) using a 100 Watt mercury lamp (Zeiss HBO100 W/2). To record the epicardial fluorescence of NADH, the emitted light was filtered (460/25 nm) and imaged using a CCD camera (Andor Ixon DV860) that has high quantum efficiency for wavelengths corresponding to NADH fluorescence (80% QE at 460 nm).

#### Optical Mapping Experiments

Hearts were stained with the potentiometric dye RH237 (Molecular Probes, 10  $\mu$ M solution) and Blebbistatin was added to the perfusate (10  $\mu$ M final concentration) to reduce motion artifact. A dual optical mapping system comprised of two CCD cameras (Andor IXON DV860s) fitted with a dual port adapter (Andor CSU Adapter Dual Cam) and a dichroic mirror (610 nm) was used to image the epicardial fluorescence of RH237 (250-500 fps) and NADH (2 fps) from the same field of view. To record optical action potentials, the epicardium was illuminated using two light emitting diodes (LumiLEDs, 530/35 nm). The resulting fluorescence of RH237 was long-pass filtered at 680 nm. NADH fluorescence was recorded with the other CCD camera as described above.

The fluorescence of RH237 was processed to subtract background fluorescence from each image and signals for each pixel were normalized. RH237 fluorescence signals were smoothed using a median temporal filter (3 sample width). Isochronal maps of activation times were generated to show wave front propagation. The average amplitude of optical action potentials at each pixel was computed to reveal spatial changes in the amount of electrically active tissue.

#### TTC Staining

Triphenyltetrazolium chloride (TTC) vital staining is a standard procedure for assessing acute necrosis. Immediately after the imaging protocol was completed, the tissue was retrogradely perfused through the coronaries with a 1.0% TTC in Tyrode solution. The heart was then submerged in the TTC solution for an additional 8 min. Metabolically active tissue appeared crimson. Necrotic tissue appeared white.

#### Experimental Results

FIG. 4A, FIG. 4B, FIG. 4C, FIG. 4D and FIG. 4E illustrate RF ablation lesions in blood-free excised rat hearts. The first set of experiments was conducted in excised hearts from healthy rats of either sex. Hearts were retrograde-perfused with Tyrode solution. The epicardium of 8 hearts was ablated and imaged. Two ablation lesions were placed next to each other on 4 of the hearts. An example of an RF ablation probe in the position to deliver a lesion onto the epicardial surface is illustrated in FIG. 4A, and the visual appearance of a typical lesion after a standard RFA ablation protocol is illustrated in FIG. 4B. As illustrated in FIG. 4B, ablations caused immediate changes in the visual appearance of the epicardial surface as a distinct area of pale tissue. The paleness corresponds to denaturation of myoglobin at temperatures above 60° C. The heart was then placed on a constant pressure perfusion system and imaged using either a single or dual CCD camera system. FIG. 4C illustrates the appearance of two distinct RF ablation lesions, as revealed by fNADH imaging, where partially ischemic tissue appears as blotchy white. As illustrated in FIG. 4C, fNADH images revealed that the areas of ablation appeared markedly dark when compared to the surrounding unablated myocardium.

After imaging, the hearts were stained with vital dye TTC, which is illustrated in FIG. 4D, and sliced transmurally to examine the ablation lesions, which is illustrated in FIG. 4E. As illustrated in FIG. 4D after TTC staining, metabolically

active tissue appears red and irreversibly damaged tissue appears white. FIG. 4E illustrates transverse slicing through the heart to show the depth of two lesions placed on opposite epicardial surfaces using two different power settings.

#### Spatial Extent and Temporal Stability of RF Ablation Lesions.

FIG. 5A and FIG. 5B illustrate lesion stability over time. Specifically, the top row shows snapshots of fNADH at different time points (2-120 minutes) after RF ablation. The white box on the top left image indicates close-up area used in the three lower snapshots, which illustrate a close-up of the lesion border over three intermediate time points (5, 10 and 30 mins).

As shown in FIG. 5A and FIG. 5B, fNADH levels in ablated tissue did not return to their pre-ablation values and the size of the lesions did not significantly change over the course of the experiments (approx. 2 hours). As illustrated by the three lower close-up snapshots in FIG. 5A and FIG. 5B, areas in the fNADH images that corresponded to the lesions became homogenously dark over time.

As illustrated in FIG. 6A, FIG. 6B and FIG. 6C, the size of the lesions measured from the fNADH images was identical to the size of the areas that stained negative for TTC. Specifically, FIGS. 6A and 6B illustrate sizes of the RF lesions as seen on fNADH-sensitive channel and after TTC staining. In FIG. 6A snapshots of the three lesions on the surface of the rabbit heart respectively illustrate the raw NADH image, inverted NADH image (i.e., the LUT scale of raw fNADH images was inverted to show lesions in white), raw TTC image and black and white TTC image (i.e., gray scale). The three graphs of FIG. 6B respectively correspond to the intensity profile through each lesion a, b, and c identified in the snapshots of FIG. 6A. As illustrated by the bar graph of FIG. 6C, widths of the lesions were not significantly different when examined using fNADH and TTC staining.

TTC staining is a common method to determine tissue viability. It relies on the ability of dehydrogenase enzymes and NADH to react with tetrazolium salts to form a formazan pigment. Since both methods rely on the presence of active NADH, the measurement of lesion size is similar for the two methods. Thus, as illustrated by the graphs in FIG. 6B, live imaging of NADH fluorescence provides an estimate of the area of TTC-positive tissue with better than 95% accuracy. From a clinical perspective, the stability of RF ablation lesions as seen in fNADH images suggests that UV-based imaging of NADH can be acquired after multiple RF ablations have been performed, since lesion appearance remains stable for several hours.

#### Identifying Functional Gaps Between RF Ablation Lesions

FIG. 7A, FIG. 7B, and FIG. 7C illustrate dual imaging of epicardial electrical activity and fNADH of the propagation through narrow isthmus between two RF lesions. As discussed above, incomplete lesions may be even more dangerous if they serve as anatomical routes for reentry and inter-lesion isthmuses as small as 1 mm can lead to recurrent conduction. To study propagation through inter-lesion isthmuses wavefronts of activity between two closely placed RF lesions were analyzed. A bipolar pacing electrode was placed on the epicardium above the lesions and current was applied at twice the diastolic threshold (2.5 mA). Paced waves caused spontaneous reentrant circuits around the lesions when a functional isthmus was present. An example of this activity is illustrated in the sequential snapshots of FIG. 7C. The three snapshots in FIG. 7A respectively illustrate an fNADH image of tissue with two lesions, an isochronal map of electrical activity of one of the reentrant circuits recorded using the voltage-sensitive dye RH237, and the superposition of the

isochronal map on the fNADH image. FIG. 7B illustrates the pseudo ECG trace reconstructed by averaging optical action potentials from all pixels in individual frame, which corresponds to the sequence shown in FIG. 7C. FIG. 7C illustrates sequential snapshots of processed RH237 sequence that illustrate propagation of paced beats and reentry around the lesions.

To create the isochronal maps and to reveal propagating wave fronts (as illustrated in FIG. 7A, FIG. 7B and FIG. 7C), optical action potentials were normalized to show propagating wave fronts in an all-or-none fashion. This is useful for illustrating propagation but it can be misleading because it obscures the true optical action potential amplitudes. To better represent true optical action potential amplitudes, the RH237 signal at each pixel was scaled as a percentage of the maximum optical action potential amplitude for all the pixels.

FIG. 8A, FIG. 8B, FIG. 8C and FIG. 8D illustrate fNADH and electrical activity across the isthmus between two RF lesions. Specifically, FIG. 8A illustrates an x-t representation of the amplitudes of five sequential action potentials along the black line in the adjacent RH237 image. In FIG. 8A the x-axis is the distance between the two lesions and the y-axis represents time with action potentials indicated by asterisks on the right. FIG. 8B illustrates the graph overlaid on the interlesion intensity profile for fNADH with the profile of the action potential amplitude. The two profiles had a correlation coefficient of  $r=0.95$ ,  $P<0.05$ . The inter-lesion profile of the optical action potential amplitude is illustrated in FIG. 8C as an x-t plot for six sequential beats, with the x-axis being the distance between the centers of the two lesions. In FIG. 8D the gap is identified by fNADH which gives it a light appearance whereas the ablated lesion is identified by lack of fluorescence which gives the tissue a dark appearance. The inter-lesion profile of action potential amplitude was then compared to the interlesion profile of fNADH intensity. The two were highly correlated ( $r=0.95$ ). These findings suggest that fNADH loss can serve as a direct marker for the diminished functional state of the tissue near the ablation site.

Lack of fNADH Indicates Muscle Damage and not Damage to Major Coronary Vessels

Abundant mitochondria that contain NADH make cardiac myocytes particularly suitable for fNADH imaging. Reduced fNADH at the site of the RF ablation lesions indicates loss of myocyte membrane integrity, as cell and mitochondrial membranes are rapidly damaged by thermal stress. Notably, cardiac muscle cell necrosis within the ablation site does not necessarily mean that the integrity of all underlying structures, such as coronary vessels, was destroyed. In the experiments a disruption of major coronary vessel structure was not observed. This is because, if vessels were disrupted, then tissue downstream of damaged vessels would become ischemic, causing fNADH to increase. Yet, as illustrated in FIG. 6A, fNADH levels near the lesions did not significantly change before and after ablation. The patches of whiter tissue occasionally seen near the ablation site occurred prior to the RF ablation event, potentially as a result of transient low perfusion that temporarily caused local ischemia. Other evidence of intact coronary structure was the homogeneity of post-ablation TTC staining: any major vessel damage would have been indicated as areas of unstained tissue outside the RF ablation lesion. However, all of the 13 RF ablation lesions made during the experiment and identified with TTC were localized strictly to the RF lesion site. Finally, as illustrated in FIG. 4B, observation of intact vessels on the epicardial surface did not indicate severe damage to major vessels at the ablation sites.

Conductive vs. Direct Resistive Heating

FIG. 9A, FIG. 9B, FIG. 9C and FIG. 9D illustrate RH237 retention within the ablation area. Specifically, FIGS. 9A-9C illustrate three sequential snapshots of rat heart bolus stained with RH237. As illustrated in FIGS. 9A-9C, RH237 fluorescence decreases over time, highlighting the lesions as areas that retain the dye. FIG. 9D illustrates the intensity of RH237 staining acquired from the four regions of interest (ROI) identified in FIG. 9A. The solid points, which trend downward over time, correspond to ROIs in unablated areas, and the open points, which remain stable over time, correspond to ROIs in the lesion area.

As illustrated in FIG. 10A, FIG. 10B, FIG. 10C and FIG. 10D, during optical mapping the washout rate of RH237 was less within the ablation lesions than in the normal tissue, which resulted in high contrast between the lesions and normal tissue in the raw RH237 images. FIG. 10A, FIG. 10B, FIG. 10C and FIG. 10D illustrate RH237 retention after RF ablation procedure compared to NADH fluorescence and visual appearance of the epicardium. FIG. 10A is a schematic representation of lesion formation by RF catheter. FIGS. 10B and 10C illustrate two different rat hearts showing a lesion in an fNADH image (the left-hand side image) and the corresponding RH237 image (the right-hand side image). The scale bars below these images correspond to 5 mm. FIG. 10D illustrates a rabbit heart with three RF ablations as it appears within fNADH, RH237 images and TTC staining images, with the scale bars below these images corresponding to 5 mm. It should be noted that a brownish rim within white TTC channel coincides with RH237 retention area. Importantly, as can be seen by a comparison of the fNADH and RH237 images in FIG. 10B and FIG. 10C, the diameter of the bright areas of RH237 (corresponding to a lesion) was significantly smaller than the area of the lesion indicated by fNADH. Lesion size in RH237 images corresponded to the internal ring-like structure often seen on both fNADH and TTC images, such as those illustrated in FIG. 6A.

The most plausible explanation for the bright RH237 areas is the acute damage to epicardial capillaries that occurs at the site of direct resistive heating immediately beneath the RF electrode. This then reduces washout of the RH237 dye, as can be seen in FIGS. 10B and 10C. RF current heats tissue through resistive heating of a narrow rim of tissue that is in direct contact with the ablation electrode. Deeper tissue heating is a result of passive heat conduction from this small annular volume. Temperatures above 50° C. are required for irreversible myocardial injury; at temperatures above 100° C., boiling occurs at the electrode-tissue contact, forming a coagulum (i.e., the brown rings in FIG. 6A). Direct comparison between two modes of imaging the lesions (fNADH and RH237) may allow direct resistive heating to be distinguished from conductive heat transfer to deeper tissue layers.

RF Lesions in Blood Perfused Rat Hearts

FIG. 11A, FIG. 11B, FIG. 11C and FIG. 11 illustrate a visualization of RF ablation lesions in blood-perfused open-chest animals. Specifically, FIG. 11A is an open chest bright-field image of a rat heart with epicardial RF ablation lesion, and FIG. 11B illustrates the same heart as observed using fNADH. As illustrated in FIG. 11C, submerging the above ablated heart in externally added blood completely obscured fNADH signals. Blood is an optically dense medium and, within the visible light band, it interferes with spectroscopic assessment of tissue properties. Therefore, a critical issue was to show the feasibility of fNADH-based imaging in blood perfused animals. This was done by placing lesions on the epicardium immediately after opening the animal's chest and acquiring fNADH images in the same way as the excised heart experiments. As illustrated in FIG. 11B, major blood

vessels appeared as dark tracks within these images, but the RF ablation lesion was clearly revealed, which indicated that mitochondria-rich cardiac muscle provides enough fNADH to reveal surrounding unablated tissue. As illustrated in FIG. 11C, the entire field became dark when the epicardial surface of the same heart was submerged in blood. As illustrated in FIG. 11D, RF ablation lesions were revealed within the fNADH images when blood was displaced from the epicardial surface using a sheet of transparent polyvinylidene chloride.

FIG. 12 illustrates an ablation lesion obtained from the left atrial tissue of a canine at the time of open heart surgery. The tissue is located near the area of atrial fibrillation pulmonary vein isolation procedures. The left atrium was opened surgically and the blood had been removed from the field. The animal was in bypass at the time to allow for normal perfusion of the atrial tissue.

FIG. 13 is an image of an ablation lesion on epicardial surface of rat heart after cryo-ablation. This image was obtained from a blood-free excised rat heart. Cryoablation was done using liquid nitrogen on a the tip of a metal tip catheter.

FIG. 14 illustrates liver perfused rat tissue that has been acutely ablated using radiofrequency ablation. This was done to illustrate how ablation lesions look on the surface of other organs.

FIG. 15 is a 2D image on the right of a standard catheter and reconstruction into 3D integrated into 3D mapping system. A computer system and program can be used to convert the acquired 2D image of NADH fluorescence into a 3D image superimposed on the atrial anatomy as displayed.

In some embodiments, a method for acquiring a real time image of ablated endocardial heart muscle tissue and unablated gaps at the pulmonary vein and left atrial junction is provided, comprising inflating an inflatable compliant balloon with transparent fluid for displacing surrounding blood to allow visualization of NADH fluorescence; illuminating with an ultra-violet light for exciting mitochondrial NADH of the pulmonary vein and left atrial tissue using UV capable fiber; detecting NADH fluorescence from the illuminated pulmonary vein and left atrial tissue using optical imaging bundle; creating a fluorescence image with a fluorescence camera by filtering the detected NADH fluorescence with 460 nm band-pass filter; wherein the detected fluorescence image shows the physiology of the ablated lesion having a dark appearance due to lack of fluorescence, gaps having a light appearance due to normal fluorescence, and any ischemic or injured tissue having a brighter halo type appearance surrounding the ablated lesion.

In some embodiments, a method for acquiring a real time image of ablated endocardial heart muscle tissue and unablated gaps at the pulmonary vein and left atrial junction is provided, comprising inflating an inflatable compliant balloon with transparent fluid for displacing surrounding blood to allow visualization of NADH fluorescence; illuminating with ultra-violet light for exciting mitochondrial NADH of the pulmonary vein and left atrial tissue using UV capable fiber; detecting NADH fluorescence from the illuminated pulmonary vein and left atrial tissue using a CMOS camera; creating a fluorescence image with a fluorescence camera by filtering the detected NADH fluorescence with 460 nm band-pass filter; wherein the detected fluorescence image shows the physiology of the ablated lesion having a dark appearance due to lack of fluorescence, gaps having a light appearance due to normal fluorescence, and any ischemic or injured tissue having a brighter halo type appearance surrounding the ablated lesion.

In some embodiments, a method of producing visualizations of ablated lesions in the pulmonary vein area and provide additional information about physiology is provided, the method comprising the steps of illuminating, using an ultraviolet light source, tissue that includes ablated tissue and unablated tissue around the ablated tissue; imaging the illuminated tissue; and producing a display of the imaged, illuminated tissue, wherein the display illustrates the ablated tissue as having less fluorescence than the unablated area around the ablated tissue. In some embodiments, the display may illustrate areas of high fluorescence surrounded by an area of lower fluorescence or lack of fluorescence. In some embodiments, the illustrated areas of high fluorescence surrounded by the area of lower fluorescence indicate that the areas of high fluorescence are not ablated. In some embodiments, the fluorescence is caused by NADH in the illuminated tissue. In some embodiments, the illumination, imaging and producing are performed while a radio frequency, cryoablation or laser catheter is used to ablate the tissue. In some embodiments, the illumination and imaging are performed using a fiber optic waveguide coupled to a tip of the lumen catheter, the fiber optic waveguide delivers ultraviolet light from the ultraviolet light source to the illuminated tissue. In some embodiments, the tissue is heart tissue. In some embodiments, the imaging of the illuminated tissue is performed without addition of chemicals to the illuminated tissue.

In some embodiments, a method of treating Atrial Fibrillation (AF) is provided, the method comprising the steps of ablating a portion of the atrial tissue; illuminating tissue using an ultraviolet light source; imaging the illuminated tissue using fluorescence camera and a filter for allowing visualization of fluorescence; producing a display of the imaged illuminated tissue; identifying gaps between ablated tissue based on the display of the imaged illuminated tissue; wherein ablated tissue is identified by lack of fluorescence which gives the tissue a dark appearance and wherein gaps constituting unablated tissue are identified by fluorescence which gives them a light appearance and ablating the identified unablated tissue gaps between ablated tissue. In some embodiments, the display illustrates the ablated tissue as having less fluorescence than the gaps.

In some embodiments, a system for imaging tissue includes a catheter having a distal end and a proximal end; an inflatable balloon disposed about the distal end of the catheter; and an optical housing extending from the distal end of the catheter into the balloon, the optical housing being configured to position inside the balloon a light source for illuminating a tissue outside the balloon and a camera for imaging the illuminated tissue.

In some embodiments, a system for imaging tissue includes a catheter having a distal end and a proximal end; an inflatable balloon disposed about the distal end of the catheter; and an optical housing extending from the distal end of the catheter into the balloon; a light source inside the balloon, the light source being supported by the optical housing and configured to excite native reduced form of nicotinamide adenine dinucleotide or nicotinamide adenine dinucleotide hydrogen (NADH) in a tissue; and a camera inside the balloon, the camera being supported by the optical housing and configured to image the tissue illuminated by the light source.

In some embodiments, a system for imaging tissue includes a catheter having a distal end and a proximal end; an irrigation port to displace blood with a fluid about the distal end of the catheter; and an optical housing extending from the distal end of the catheter, the optical housing being configured to support a light emitting diode light source for illuminating

tissue and a visualization device including a plurality of image sensors that convert an optical image into an electronic signal for imaging the illuminated tissue.

In some embodiments, a system for imaging tissue includes a sheath for infusing a fluid capable of displacing blood and transmitting light; a catheter disposed within the sheath, the catheter having a distal end and a proximal end; an optical housing extending from the distal end of the catheter, the optical housing being configured to support a light emitting diode light source for illuminating tissue and a visualization device including a plurality of image sensors that converts an optical image into an electronic signal for imaging the illuminated tissue.

In some embodiments, a method for imaging tissue includes advancing to a tissue a catheter comprising an inflatable balloon disposed about the distal end of the catheter and an optical housing extending from the distal end of the catheter into the balloon to position a light source and a camera inside the balloon; ablating the tissue; illuminating with the light source an area of tissue including tissue treated by ablation and surrounding tissue to excite NADH in the area of tissue; imaging with an imaging device the area of tissue to detect NADH fluorescence of the area of tissue; and producing a display of the imaged, illuminated tissue, the display illustrating ablated tissue as having less fluorescence than non-ablated tissue.

The foregoing disclosure has been set forth merely to illustrate various non-limiting embodiments of the present disclosure and is not intended to be limiting. Since modifications of the disclosed embodiments incorporating the spirit and substance of the disclosure may occur to persons skilled in the art, the presently disclosed embodiments should be construed to include everything within the scope of the appended claims and equivalents thereof.

What is claimed is:

1. A system for imaging endocardial tissue comprising:
  - an endovascular catheter having a distal end and a proximal end, the endovascular catheter being sized for an endovascular approach to an endocardial tissue;
  - an inflatable balloon disposed about the distal end of the endovascular catheter, the balloon being made of a compliant ultraviolet (UV) light transparent material and shaped for placement adjacent the endocardial tissue;
  - a guidewire for guiding the endovascular catheter to the endocardial tissue;
  - an ablation member disposed outside the balloon for ablation of a portion of the endocardial tissue; and
  - an optical housing extending from the endovascular catheter into the balloon, the optical housing comprising a UV light source emitting light having a wavelength between about 300 nm and about 400 nm for illuminating the endocardial tissue outside the balloon to excite NADH fluorescence in the endocardial tissue and a camera for imaging the illuminated tissue, wherein the UV light source and the camera are positioned inside the balloon beyond the distal tip of the endovascular catheter.
2. The system of claim 1, wherein the light source is a UV light emitting diode (LED).
3. The system of claim 1, wherein the camera includes image sensors that convert an optical image into an electronic signal.
4. The system of claim 1, wherein a gap formed between an outside surface of the optical housing and an inner wall of the balloon, the gap providing a fluid path between an inflation lumen of the endovascular catheter and the balloon for inflating and deflating the balloon.

5. The system of claim 1, wherein the optical housing is rotatable in relation to the balloon.

6. The system of claim 1 further comprising a support tube extending beyond the distal tip of the catheter to provide a structural support for the balloon.

7. The system of claim 6 further comprising a tip around a distal end of the support tube, the tip being configured to act as an ablation element.

8. The system of claim 6, wherein the support tube includes an inner lumen in communication with an inner lumen of the catheter for passing an ablation member distally of the balloon.

9. The system of claim 1 further comprising a first light source and a second light source capable of generating light of a different wavelength than the first light source.

10. The system of claim 1 further comprising a display system connected to the camera for generating an image of the illuminated tissue based on a NADH fluorescence detected by the camera.

11. The system of claim 10, wherein the camera and the display system are in a wireless communication.

12. The system of claim 1 further comprising a filter having a center wavelength of 460 nm with a 50 nm bandwidth coupled with the camera.

13. The system of claim 1, wherein the camera is coupled to a charge-coupled device (CCD) camera having a quantum efficiency of at least about 50% to about 70% at about 460 nm.

14. The system of claim 1, wherein the camera is coupled to a charge-coupled device (CCD) camera having a quantum efficiency of about 90% at about 460 nm.

15. A system for imaging endocardial tissue comprising:
 

- an endovascular catheter having a distal end and a proximal end, the endovascular catheter being sized for an endovascular approach to an endocardial tissue;
- a support tube extending beyond the distal end of the endovascular catheter and having a tip around a distal end of the support tube;
- an inflatable balloon disposed about the distal end of the endovascular catheter, the balloon being made of a compliant ultraviolet (UV) light transparent material and shaped for placement adjacent the endocardial tissue;
- a guidewire for guiding the endovascular catheter to the endocardial tissue;
- an ablation member disposed outside the balloon for ablation of a portion of the endocardial tissue; and
- an optical housing extending from the distal end of the endovascular catheter into the balloon;
- a UV light source inside the balloon, the light source being supported by the optical housing, the UV light source producing light having a wavelength between about 300 nm and about 400 nm for illuminating the endocardial tissue outside the balloon to excite NADH in the endocardial tissue; and
- a camera inside the balloon, the camera being supported by the optical housing and configured to detect NADH fluorescence from the endocardial tissue illuminated by light from the UV light source to image the endocardial tissue illuminated by the UV light source.

16. The system of claim 15, wherein the optical housing is rotatable in relation to the balloon to rotate the camera and the light source in relation to the balloon.

17. The system of claim 15 comprising a second light source for providing white light.

18. The system of claim 15 further comprising a filter having a center wavelength of 460 nm with a 50 nm bandwidth coupled with the camera.

25

19. The system of claim 15, wherein the camera is coupled to a charge-coupled device (CCD) camera having a quantum efficiency of at least about 50% to about 70% at about 460 nm.

20. The system of claim 15, wherein the camera is coupled to a charge-coupled device (CCD) camera having a quantum efficiency of about 90% at about 460 nm.

21. A system for imaging tissue comprising:

an endovascular catheter having a distal end and a proximal end, the endovascular catheter being sized for an endovascular approach to a cardiac tissue;

a guidewire for guiding the endovascular catheter to the cardiac tissue;

an ablation member disposed at the distal end of the endovascular catheter;

an irrigation port to displace blood with a fluid about the distal end of the catheter; and

an optical housing extending from the distal end of the catheter, the optical housing being configured to support a light emitting diode (LED) light source, the LED light source emitting light having a wavelength between about 300 nm and about 400 nm for illuminating the cardiac tissue to excite NADH in the cardiac tissue and a visualization device including a plurality of image sensors that convert an optical image into an electronic signal for imaging the illuminated tissue

an inflatable balloon disposed about the distal end of the endovascular catheter, the balloon being made of a compliant ultraviolet (UV) light transparent material and shaped for placement against the cardiac tissue; wherein the light source and the visualization device are positioned inside the balloon beyond the distal tip of the endovascular catheter.

22. A system for imaging tissue comprising:

a sheath for infusing a fluid capable of displacing blood and transmitting light;

an endovascular catheter disposed within the sheath, the endovascular catheter having a distal end and a proximal end, the endovascular catheter being sized for an endovascular approach to a cardiac tissue;

a guidewire for guiding the endovascular catheter to the cardiac tissue;

an ablation member disposed at the distal end of the endovascular catheter;

an optical housing extending from the distal end of the catheter, the optical housing being configured to support a light emitting diode (LED) light source, the LED light source producing light having a wavelength between about 300 nm and about 400 nm for illuminating the cardiac tissue to excite NADH in the cardiac tissue and a visualization device including a plurality of image sensors that convert an optical image into an electronic signal for imaging the illuminated tissue

an inflatable balloon disposed about the distal end of the endovascular catheter, the balloon being made of a compliant ultraviolet (UV) light transparent material and shaped for placement against the cardiac tissue; wherein the light source and the visualization device are positioned inside the balloon beyond the distal tip of the endovascular catheter.

23. A method for imaging tissue comprising:

advancing a catheter over a guidewire through an endovascular system to a cardiac tissue, the catheter comprising an inflatable balloon disposed about a distal end of the catheter, the balloon being made of a compliant ultraviolet (UV) light transparent material and shaped for placement adjacent the cardiac tissue; and an optical

26

housing extending from the distal end of the catheter into the balloon to position a UV light source and a camera inside the balloon;

ablating the cardiac tissue with an ablation member disposed at the distal end of the catheter;

exciting NADH in an area of the cardiac tissue including the cardiac tissue treated by ablation by illuminating the cardiac tissue with a light from the UV light source having a wavelength between about 300 nm and about 400 nm from the UV light source;

imaging with the imaging device the area of the cardiac tissue to detect NADH fluorescence of the area of tissue; and

producing a display of the imaged, illuminated cardiac tissue, the display illustrating ablated cardiac tissue as having less fluorescence than non-ablated cardiac tissue.

24. The method of claim 23, wherein the cardiac tissue is a heart muscle tissue.

25. The method of claim 23 further comprising distinguishing between ablated cardiac tissue having a dark appearance and non-ablated cardiac tissue having a lighter appearance.

26. The method of claim 23 further comprising ablating additional non-ablated cardiac tissue identified by distinguishing between the ablated cardiac tissue and the non-ablated cardiac tissue based on the amount of fluorescence.

27. The method of claim 23 further comprising distinguishing between ablated cardiac tissue, edematous cardiac tissue, and non-ablated cardiac tissue.

28. The method of claim 23 further comprising performing a registration and overlay of the produced images onto an anatomy of a patient as seen using imaging modalities such as an MRI image, computed tomography (CT) image, ultrasound image and three dimensional reconstructions thereof.

29. The method of claim 23 further comprising registering and overlaying the produced images onto an anatomy of a patient as seen using electroanatomical mapping, anatomical reconstruction, and navigational systems.

30. A system for imaging endocardial tissue comprising:

an endovascular catheter having a distal end and a proximal end, the endovascular catheter being sized for an endovascular approach to an endocardial tissue;

an inflatable balloon disposed about the distal end of the endovascular catheter, the balloon being made of a compliant ultraviolet (UV) light transparent material and shaped for placement against the endocardial tissue;

a guidewire for guiding the endovascular catheter to the endocardial tissue;

an ablation member disposed outside the balloon for ablation through the endovascular catheter;

a light source located outside the endovascular catheter, the light source providing light having a wavelength between about 300 nm and about 400 nm;

one or more light transmitting fibers having a distal end inside the inflatable balloon and being connected to the light source;

a charge-coupled device (CCD) camera located outside the endovascular catheter; and

one or more imaging fibers having a distal end inside the inflatable balloon and being connected to the CCD camera.

31. The system of claim 30 further comprising a filter having a center wavelength of 460 nm with a 50 nm bandwidth coupled with the camera.

32. The system of claim 30, wherein the CCD camera has a quantum efficiency of at least about 50% to 70% at about 460 nm.

33. The system of claim 30, wherein the CCD camera has a quantum efficiency of about 90% at about 460 nm.

\* \* \* \* \*

专利名称(译)	用于可视化消融组织的系统和方法		
公开(公告)号	<a href="#">US9084611</a>	公开(公告)日	2015-07-21
申请号	US13/624902	申请日	2012-09-22
申请(专利权)人(译)	乔治华盛顿大学 ,		
当前申请(专利权)人(译)	乔治华盛顿大学 LUXCATH , LLC		
[标]发明人	AMIRANA OMAR ARMSTRONG KENNETH C KAY MATTHEW W MERCADER MARCO A RANSBURY TERRANCE J SARVAZYAN NARINE		
发明人	AMIRANA, OMAR ARMSTRONG, KENNETH C. KAY, MATTHEW W. MERCADER, MARCO A. RANSBURY, TERRANCE J. SARVAZYAN, NARINE		
IPC分类号	A61B18/14 A61B5/00 A61B19/00 A61B18/00 A61B18/02		
CPC分类号	A61B18/1492 A61B5/004 A61B5/0084 A61B19/5202 A61B19/5212 A61B2018/0022 A61B2018/0212 A61B2019/2211 A61B2019/5291 A61B1/00082 A61B1/00186 A61B1/043 A61B1/05 A61B1/0638 A61B1/0676 A61B1/0684 A61B90/30 A61B90/35 A61B90/361 A61B2034/301 A61B2090/365 Y02A90 /26 A61B1/00009 A61B1/00045 A61B5/0044 A61B5/14503 A61B5/14546 A61B5/1459 A61B5/6853 A61B18/00		
审查员(译)	LUONG , PETER		
优先权	61/537798 2011-09-22 US		
其他公开文献	US20130079645A1		
外部链接	<a href="#">Espacenet</a> <a href="#">USPTO</a>		

摘要(译)

公开了用于可视化消融组织的系统和方法。在一些实施方案中，一种用于对组织成像的系统，包括：具有远端和近端的导管；围绕导管远端设置的可充气气囊；光学壳体从导管的远端延伸到球囊中，光学壳体被配置成在球囊内部定位用于照射球囊外部的组织的光源和用于对照射的组织成像的照相机。

