



US006637935B2

(12) **United States Patent**
Chen

(10) **Patent No.:** **US 6,637,935 B2**
(45) **Date of Patent:** **Oct. 28, 2003**

(54) **STRUCTURE OF A CLINICAL THERMOMETER**

(76) Inventor: **Min-Ying Chen**, 10 Fl., No. 43, Kuang Ming Six Rd., Chu Pei Hsien (TW)

(*) Notice: Subject to any disclaimer, the term of this patent is extended or adjusted under 35 U.S.C. 154(b) by 0 days.

(21) Appl. No.: **10/038,606**

(22) Filed: **Jan. 8, 2002**

(65) **Prior Publication Data**

US 2003/0128738 A1 Jul. 10, 2003

(51) **Int. Cl.**⁷ **G01K 1/16; G01K 7/00; A61B 5/00**

(52) **U.S. Cl.** **374/185; 374/208; 600/549**

(58) **Field of Search** **374/163, 208, 374/194, 170, 169, 185, 184; 600/549**

(56) **References Cited**

U.S. PATENT DOCUMENTS

4,453,835 A *	6/1984	Clawson et al.	374/185
4,556,837 A *	12/1985	Kobayashi et al.	320/2
4,729,672 A *	3/1988	Takagi	374/208
4,743,121 A *	5/1988	Takagi et al.	374/163
4,929,092 A *	5/1990	Taguchi et al.	374/183
5,013,161 A *	5/1991	Zaragoza et al.	374/208
5,165,798 A *	11/1992	Watanabe	374/208
6,068,399 A *	5/2000	Tseng	374/163
6,101,094 A *	8/2000	Kermaani et al.	361/720
6,379,039 B1 *	4/2002	Tseng	374/163
6,419,388 B2 *	7/2002	Lee	374/208
6,462,640 B2 *	10/2002	Muziol	338/28

FOREIGN PATENT DOCUMENTS

EP	0410186 A1 *	7/1990	G01K/7/00
JP	07027626 A *	1/1995	G01K/7/00
JP	10221177 A *	8/1998	G01K/7/00

* cited by examiner

Primary Examiner—Christopher W. Fulton

Assistant Examiner—G. Verbitsky

(74) *Attorney, Agent, or Firm*—Leong C. Lei

(57) **ABSTRACT**

An improved structure of a clinical thermometer in which a dielectric (such as air or heat conductive, hard or soft foam with a low conductivity coefficient) is packed into the metal tip section of its measuring extremity such that the inductive component and the inductor wire disposed in the metal tip section are in a helical arrangement and entirely attached to the inner wall of the metal tip section, allowing inducted temperature to attain heat equilibrium as well as swift heat conduction, thereby enabling the clinical thermometer to immediately indicate the precise temperature. The clinical thermometer body is of one-piece molded construction and, furthermore, a pliable section having exceptional dustproof and waterproof properties is sleeved over the depressible flat element of its on-off switch. Slanted surfaces of mutual contact and conjunction are disposed at an appropriate area of the measuring extremity and a rotation structure consisting of a flange mount and insertion holes at the contact and conjunction surfaces enable the rotation of the measuring extremity and its rotating to an appropriate angle. As such, when the user employs the clinical thermometer to measure temperature, the movable structure of the measuring extremity enables ergonomic and comfortable grasping and manual retention.

2 Claims, 7 Drawing Sheets

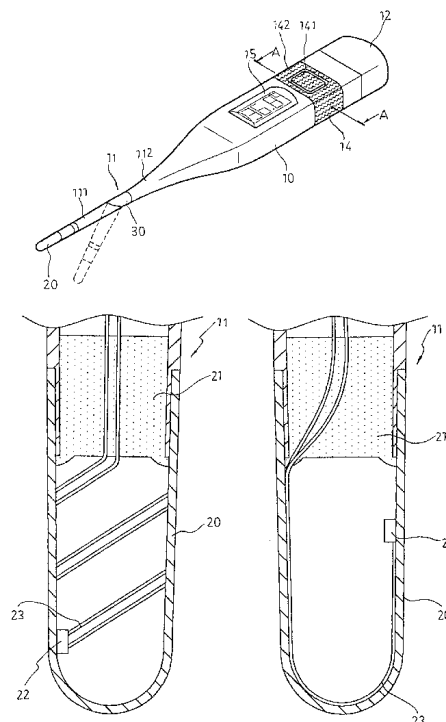

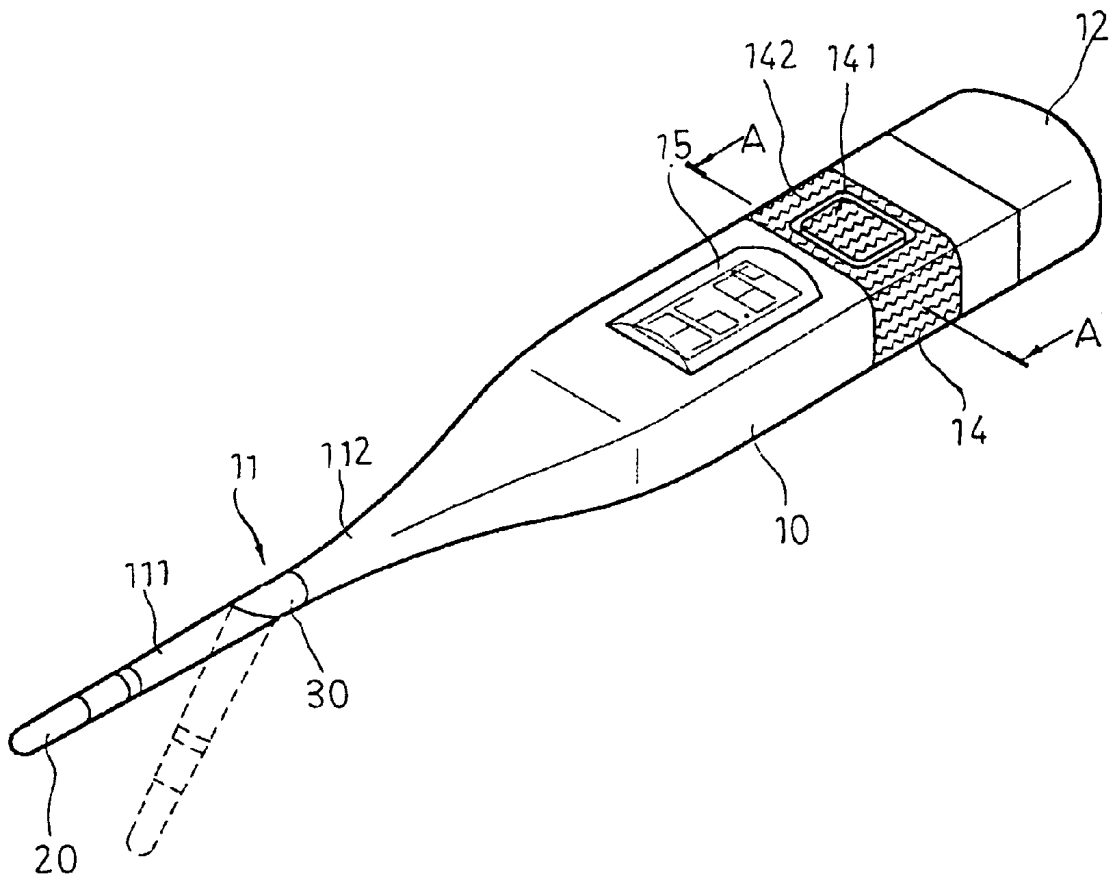

FIG. 1

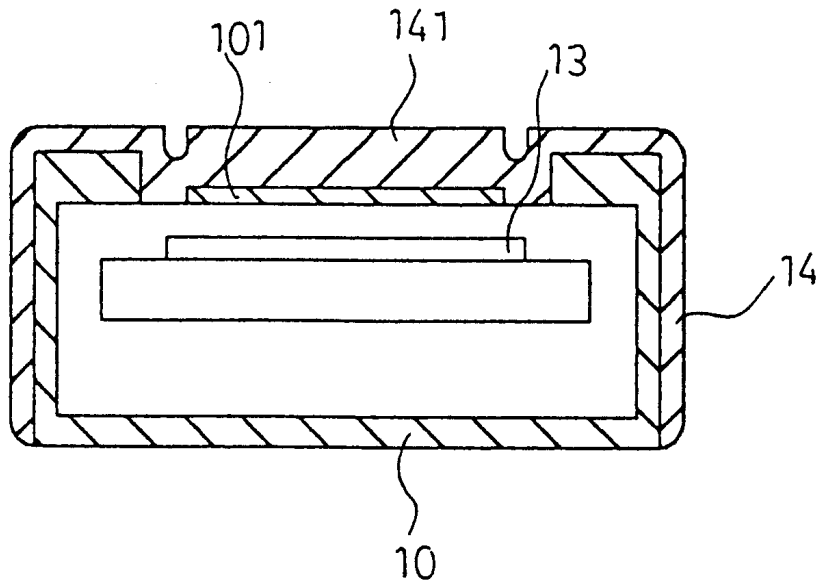

FIG. 2A

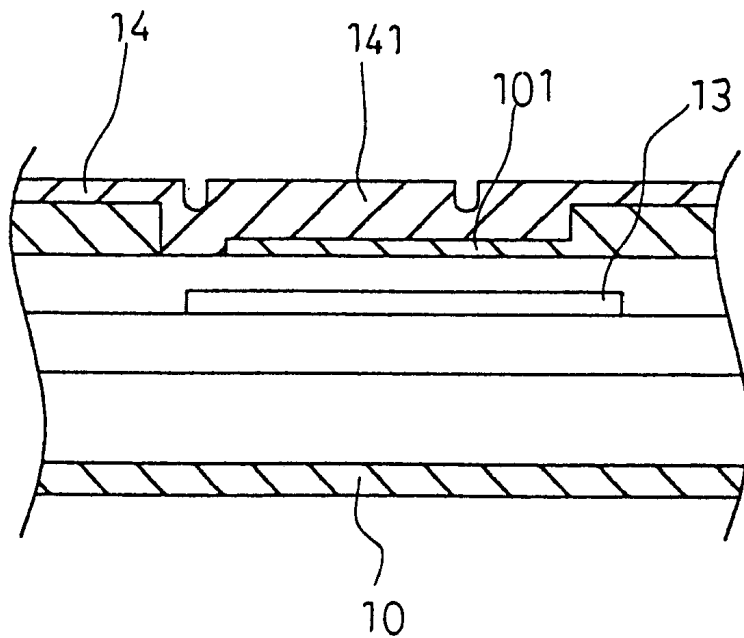

FIG. 2B

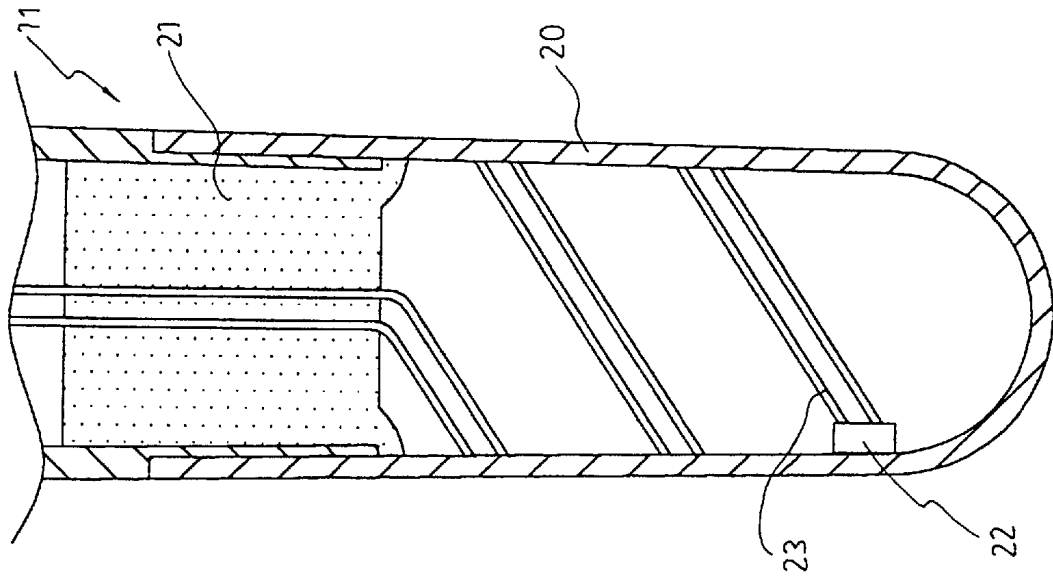

FIG. 3

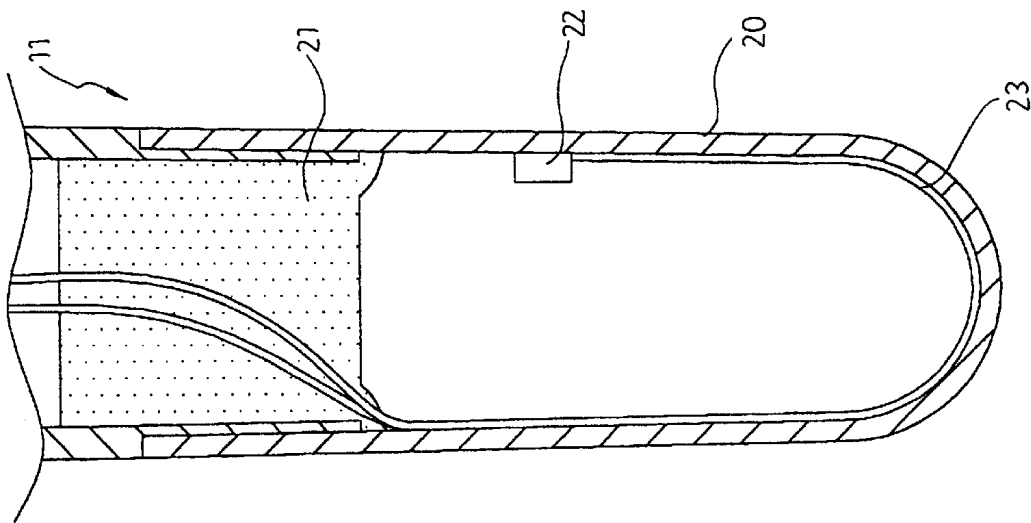

FIG. 4

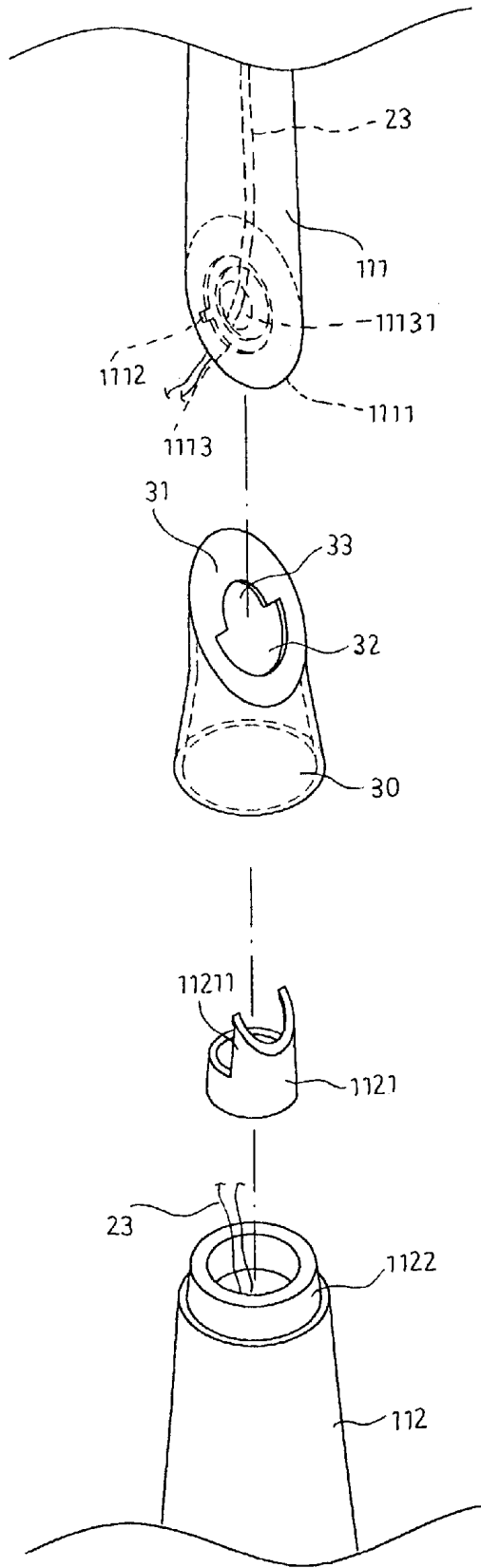

FIG. 5

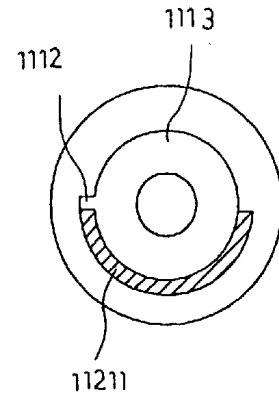
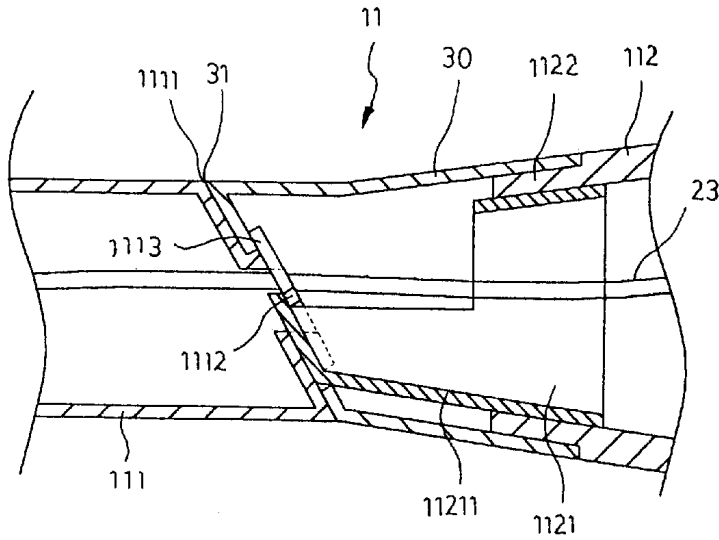

FIG. 6A

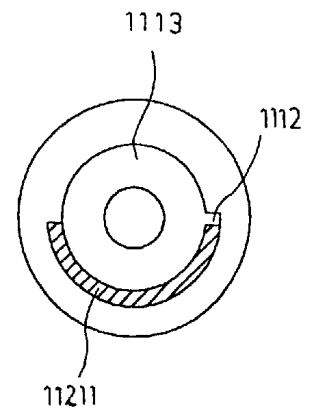
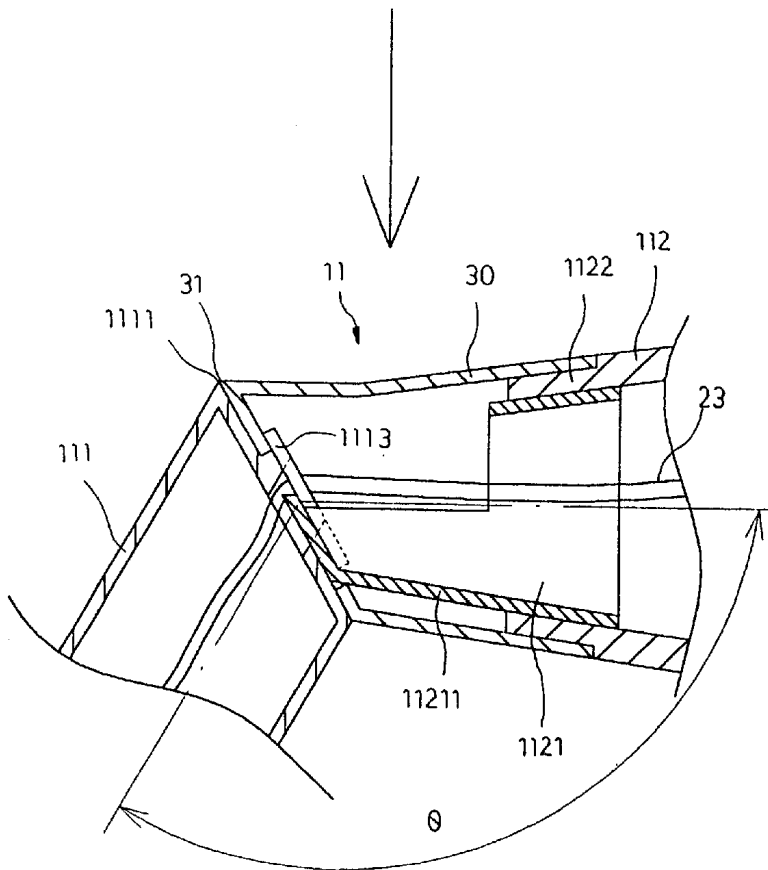

FIG. 6B

FIG. 6

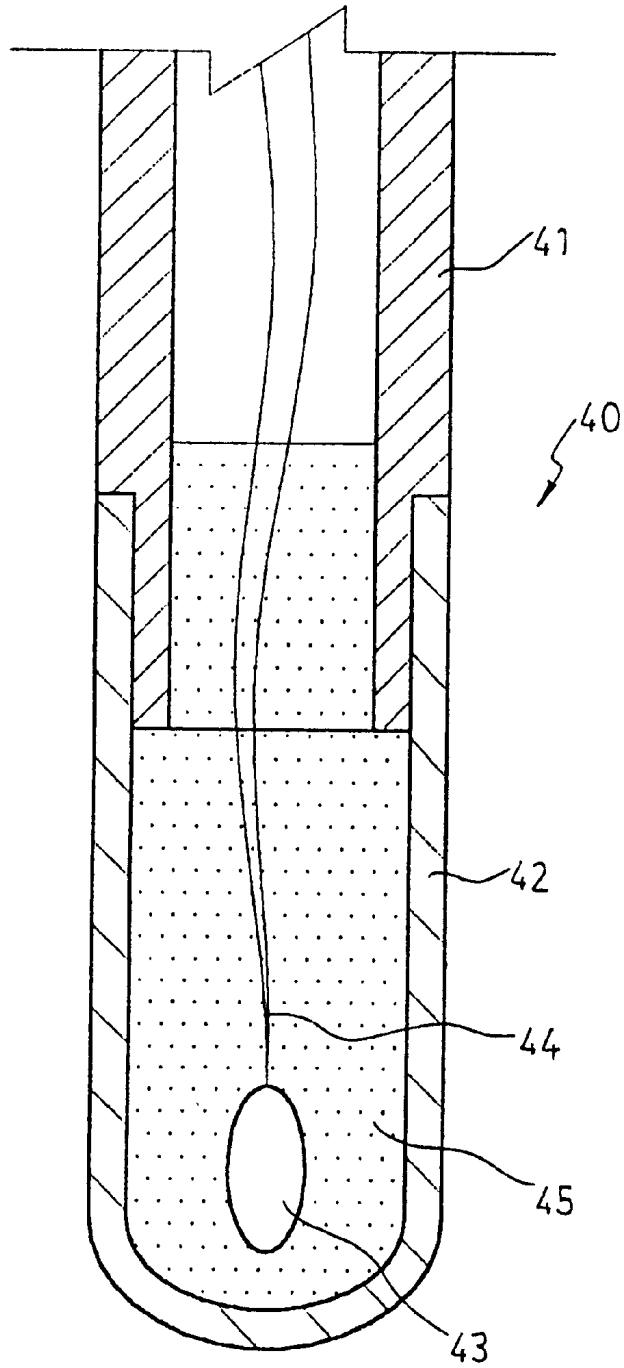

FIG. 7

(PRIOR ART)

STRUCTURE OF A CLINICAL THERMOMETER

BACKGROUND OF THE INVENTION

1) Field of the Invention

The invention herein relates to electronic thermometers, specifically an improved structure of a clinical thermometer.

2) Description of the Prior Art

Conventional electronic clinical thermometers generally have the following structural drawbacks:

- (1) Referring to FIG. 7, a conventional electronic clinical thermometer **40** structure typically consists of a sleeve-type metal tip section **42** over its measuring extremity **41**, an inductive component **43** and an inductor wire **44** disposed in the metal tip section **42**, with the inducting of body temperature by the said inductive component **43** occurring such that the temperature is indicated on a display screen at the surface of the clinical thermometer **40**; since one observes that solidified rubber **45** is contained in the metal tip section **42** to fix the inductive component **43** and, furthermore, conjoin the measuring extremity **41** to the metal tip section **42**, although the metal tip section **42** is capable of conducting body heat when the metal tip section **42** contacts the epidermis, the poor heat conduction efficiency of the internal solidified rubber **45** makes it impossible for body heat to be equally and fully induced around the inductive component **43** disposed at the lower extent of the metal tip section **42** (because the inductive component **43** and the inductor wire **44** situated inside the metal tip section **42** do not contact the metal tip section **42**) and, furthermore, based on Fourier's Law of thermodynamics (heat conduction speed is directly proportional to contact area), temperature inducted by the inductive component **43** and the inductor wire **44** cannot be rapidly heat conducted and cannot attain heat equilibrium, with the heat so inducted increasingly conveyed to the tip and dissipated; as such, the clinical thermometer **40** requires a longer time to measure body temperature and, furthermore, at an extreme degree of error
- (2) Conventional clinical thermometers **40** have a temperature display screen that is typically mounted in an opening provided for viewing the said display screen and since it is mounted a short distance away from a push-type power switch, waterproof and dustproof qualities are not optimal; furthermore, the display screen utilizes an extremely small alphanumeric character font and lacks an effective means of magnification.
- (3) Conventional clinical thermometers **40** have a measuring extremity **41** of a gradually reduced diameter that tapers towards its most anterior end with a hard exterior surfacing for measuring under-arm or oral body temperature and, furthermore, the measuring extremity **41** cannot be articulated to an appropriate angle; as a result, when measuring under-arm temperature, the extremity is held within the armpit and maintained protruding from garments, requiring the user to squeeze the said clinical thermometer in place and which causes considerable user discomfort; some clinical thermometers now available have flexible measuring extremities, but since they automatically revert to their original shape, they cannot be positioned without manual intervention.

Since the said structural inadequacies of conventional clinical thermometers have not been refined into a more ideal arrangement, the inventor of the invention herein successfully designed an improved structure clinical thermometer that has undergone extensive application testing based on experience gained from years of engagement in product design and development.

SUMMARY OF THE INVENTION

The objective of the invention herein is to provide a clinical thermometer structure in which inducted temperature rapidly attains heat equilibrium and rapid heat conduction to immediately indicate accurate temperature. In the said structure, a dielectric (such as air or heat conductive, hard or soft foam with a low conductivity coefficient) is packed into the metal tip section of its measuring extremity such that the inductive component and the inductor wire disposed in the metal tip section are entirely attached to the inner wall of the metal tip section, allowing inducted temperature to attain heat equilibrium as well as the swift heat conduction, thereby enabling the clinical thermometer of the present invention to immediately indicate the precise temperature.

Another objective of the invention herein is to provide a clinical thermometer structure having superior dustproof and waterproof qualities. In the said structure, the clinical thermometer body is of one-piece molded construction and, furthermore, a pliable section having exceptional dustproof and waterproof properties is sleeved over the depressible flat element of its on-off switch.

Yet another objective of the invention herein is to provide a clinical thermometer structure in which the measuring extremity can be adjusted to an appropriate angle to facilitate utilization. In the said structure, slanted surfaces of mutual contact and conjunction are disposed at an appropriate area of the measuring extremity and a rotation structure consisting of a flange mount and insertion holes at the contact and conjunction surfaces enable the rotation of the measuring extremity and its rotating to an appropriate angle; as such, when the user employs the clinical thermometer to measure temperature, the movable structure of the measuring extremity enables ergonomic and comfortable grasping and manual retention.

BRIEF DESCRIPTION OF THE DRAWINGS

FIG. 1 is an isometric drawing of the invention herein.

FIGS. 2A and 2B are cross-sectional drawings of the pliable section of the invention herein as viewed from a frontal and lateral perspective.

FIG. 3 is a cross-sectional drawing of the measuring extremity and metal tip section interior structure of the invention herein.

FIG. 4 is a cross-sectional drawing of another measuring extremity and metal tip section interior structure of the invention herein.

FIG. 5 is an exploded drawing of the measuring extremity rotation structure of the invention herein.

FIG. 6 is a cross-sectional drawing of the measuring extremity of the invention herein after rotation to an angle.

FIGS. 6A and 6B are end views FIG. 6.

FIG. 7 is a cross-sectional drawing of the measuring extremity and metal tip interior structure of a conventional clinical thermometer.

DETAILED DESCRIPTION OF THE INVENTION

Referring to FIG. 1, FIGS. 2A and 2B, the structure of the invention herein is comprised of a clinical thermometer

body **10**, a measuring extremity **11** conjoined to the body **10**, a metal tip section **20** sleeved onto the measuring extremity **11**, and a rear cover **12** situated on the end of the body **10**, wherein the clinical thermometer body **10** is of one-piece molded construction such that the entire body is both dustproof and waterproof. A U-shaped pliable section **14** is situated over a thermometer on-off switch **13** flat element **101** of the body **10**, a push block **141** is disposed on the said pliable section **14** that provides for the pressing in and, furthermore, bending of the flat element **101** slightly downward such that the depressing the push block **141** actuates the on-off switch **13** to toggle on the circuit within the interior section of the clinical thermometer, while the space between the flat element **101** and the pliable section **14** is filled in to seal the on-off switch **13** such it is waterproof and dustproof, and the said pliable section **14** has a coarse pattern **142** on its surface to facilitate manual grasping. Furthermore, the body **10** has a one-piece convex bezel **15** mounted over its display screen that magnifies the measured temperature alphanumeric characters indicated by the thermometer to facilitate easy viewing by the user, the said body **10** is transparent where the convex bezel **15** is mounted, with the remaining portion of the body **10** sharing same color as its inner walls.

Referring to FIG. 3, hard rubber **21** is disposed at the conjoinment area between the metal tip section **20** of the invention herein and the clinical thermometer body **10** to reinforce and fix the inductor wire **23**, and a dielectric (such as air or heat conductive, hard or soft foam with a low conductivity coefficient) is packed into the metal tip section **20** such that the inductive component **22** and the inductor wire **23** disposed in the metal tip section **20** are in a helical arrangement and entirely attached to the inner wall of the metal tip section **20**, allowing inducted temperature to rapidly and fully attain equilibrium as well as the swift heat conduction in accordance with Fourier's Law of thermodynamics (heat conduction speed is directly proportional to contact area), thereby enabling the clinical thermometer of the present invention to immediately indicate the precise temperature.

Referring to FIG. 4, the inductive component **22** and the inductor wire **23** are not in a helical arrangement but likewise directly and entirely attached to the inner wall of the metal tip section **20** such that inducted temperature rapidly and fully attains heat equilibrium and swiftly becomes heat conductive.

Referring to FIG. 5 and FIGS. 6, 6A and 6B, the rotation structure of the measuring extremity **11** of the invention herein features a design in which the measuring extremity **11** consists of an anterior portion **111** and a base portion **112**, each formed with a slanted surface of mutual contact and conjoinment; a flange mount **1113** having a lock rib **1112** is disposed on the slanted surface **1111** of the anterior portion **111** and a lock sleeve **1121** having a projecting engagement edge **11211** is situated inside the base portion **112**; a stepped section **1122** is formed on the base portion **112** that provides for the fitting on of a hollow metal sleeve **30** such that the metal sleeve **30** is contained within the lock sleeve **1121**; and the said metal sleeve **30** has a slanted surface **31**, with a large insertion hole **32** merged to a small insertion hole **33** formed in the slanted surface **31**.

When the said structure is assembled, the slanted surfaces **1111** and **31** are brought together and the flange mount **1113** is slipped into the large insertion hole **32** which also enables its sliding into the small insertion hole **33** and as such, the

anterior portion **111** and the base portion **112** are in a conjoined arrangement capable of rotation; the front end of the lock sleeve **1121** engagement edge **11211** is against the anterior portion **111** slanted surface **1111** and, furthermore, extended into the smaller diameter root section of the flange mount **1113** and thus the large insertion hole **32** is retentionally occupied to prevent the separation of the anterior portion **111** from the base portion **112** during rotation; the lock rib **1112** is normally against one side of the engagement edge **11211** to provide static positioning support after the measuring extremity **11** is rotated; furthermore, the inductor wire **23** is inserted through a hole **11131** formed in the flange mount **1113** and extended into the clinical thermometer body **10**.

When the measuring extremity **11** anterior portion **111** is rotated, the anterior portion **111** is rapidly postured due its slanted surface **1111** into an appropriate angle (the embodiments of the invention herein are capable of a 120-degree angle) at the base section **112** conjoinment point and, furthermore, since the flange mount **1113** lock rib **1112** are against the other side of the engagement edge **11211** following rotation, the rotated angle of the measuring extremity **11** is maintained in a fixed position; as such, when the user employs the clinical thermometer to measure temperature, the structure of the movable anterior portion **111** enables ergonomic and comfortable grasping and manual retention.

I claim:

1. A structure of a clinical thermometer comprised of a clinical thermometer body, a measuring extremity conjoined to said body, a metal tip section sleeved onto said measuring extremity having an inductive component and inductor wire disposed inside, and a rear cover situated on the end of said body, wherein said inductive component and said inductor wire disposed in said metal tip section are entirely attached to the inner wall of said metal tip section such that inducted temperature attains heat equilibrium and heat conduction, enabling the clinical thermometer to immediately indicate the temperature, wherein said measuring extremity has a rotation structure consisting of an anterior portion and a base portion, each formed with a slanted surface of mutual contact and conjoinment, and wherein a flange mount having a lock rib is disposed on the slanted surface of said anterior portion and a lock sleeve having a projecting engagement edge is situated inside said base portion; a stepped section is formed on said base portion that provides for the fitting on of a hollow metal sleeve such that said metal sleeve is contained within said lock sleeve; and said metal sleeve has a slanted surface, with a large insertion hole merged to a small insertion hole formed in said slanted surface; when said structure is assembled, said slanted surfaces of said anterior portion and said base portion are brought together and said flange mount is slipped into said large insertion hole which also enables its sliding into said small insertion hole such that said anterior portion and said base portion are in a conjoined arrangement capable of rotation; the front end of said lock sleeve engagement edge is against said anterior portion slanted surface and, furthermore, extended into the smaller diameter root section of said flange mount to prevent the separation of said anterior portion from said base portion during rotation.

2. The structure of a clinical thermometer as claimed in claim 1, wherein said flange mount has a hole formed in that provides for the insertion and extension of said inductor wire into said clinical thermometer body.

专利名称(译)	体温计的结构		
公开(公告)号	US6637935	公开(公告)日	2003-10-28
申请号	US10/038606	申请日	2002-01-08
[标]申请(专利权)人(译)	陈敏莹		
申请(专利权)人(译)	陈民英		
当前申请(专利权)人(译)	陈民英		
[标]发明人	CHEN MIN YING		
发明人	CHEN, MIN-YING		
IPC分类号	G01K13/00 A61B5/01 G01K1/16 G01K7/00 A61B5/00		
CPC分类号	G01K13/002		
代理机构(译)	林雷, 鸿C.		
其他公开文献	US20030128738A1		
外部链接	Espacenet USPTO		

摘要(译)

一种改进的体温计结构，其中电介质（例如空气或导热，具有低导电系数的硬或软泡沫）被包装到其测量末端的金属尖端部分中，使得电感元件和电感线布置在金属尖端部分中，金属尖端部分是螺旋状排列并且完全连接到金属尖端部分的内壁，允许引入的温度达到热平衡以及快速的热传导，从而使体温计能够立即指示精确的温度。临床温度计主体是一件式模制结构，此外，具有优异防尘和防水性能的柔韧部分套在其通断开关的可按压扁平元件上。相互接触和结合的倾斜表面设置在测量末端的适当区域处，并且在接触和结合表面处由凸缘安装件和插入孔组成的旋转结构使得测量末端的旋转及其旋转到适当的角度。因此，当用户使用体温计来测量温度时，测量末端的可移动结构能够实现符合人体工程学且舒适的抓握和手动保持。

