



US 20140309519A1

(19) **United States**
(12) **Patent Application Publication**
Huang et al.

(10) **Pub. No.: US 2014/0309519 A1**
(43) **Pub. Date: Oct. 16, 2014**

(54) **MAGNETIC RESONANCE THERMOGRAPHY: HIGH RESOLUTION IMAGING FOR THERMAL ABNORMALITIES**

Publication Classification

(71) Applicant: **KONINKLIJKE PHILIPS N.V., EINDHOVEN (NL)**

(51) **Int. Cl.**
A61B 5/055 (2006.01)
A61B 5/00 (2006.01)
A61N 5/10 (2006.01)
A61B 5/01 (2006.01)
A61N 7/02 (2006.01)

(72) Inventors: **Feng Huang**, Gainesville, FL (US);
Arne Reykowski, Gainesville, FL (US);
George Randall Duensing, Gainesville, FL (US)

(52) **U.S. Cl.**
CPC . *A61B 5/055* (2013.01); *A61B 5/01* (2013.01);
A61N 7/02 (2013.01); *A61N 5/1048* (2013.01);
A61B 5/742 (2013.01); *A61B 5/7282* (2013.01)
USPC **600/411; 600/412**

(21) Appl. No.: **14/368,306**

(22) PCT Filed: **Dec. 13, 2012**

(86) PCT No.: **PCT/IB2012/057260**

§ 371 (c)(1),
(2), (4) Date: **Jun. 24, 2014**

Related U.S. Application Data

(60) Provisional application No. 61/580,412, filed on Dec. 27, 2011.

(57) **ABSTRACT**

A magnetic resonance scanner (12) is configured for themographic imagin. One or more processors (28) receive (56) thermal image data from the magnetic resonance scanner and reconstruct at least one thermal image in which each voxel includes a measure of temperature change. The one or more processors identify (58) thermally abnormal voxels. A display (44) displays at least one reconstructed image with the identified abnormal thermal locations.

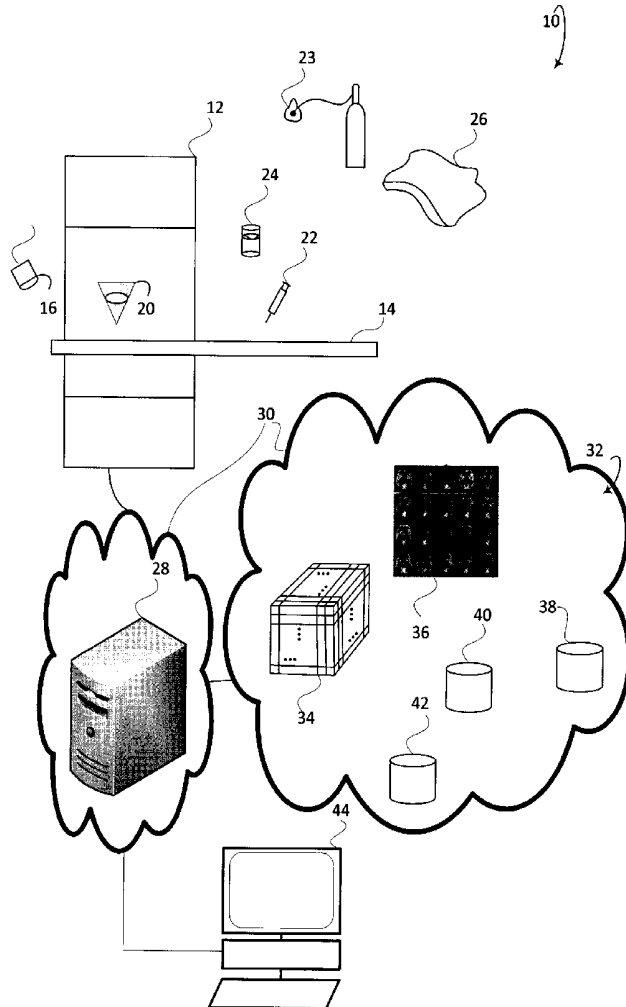

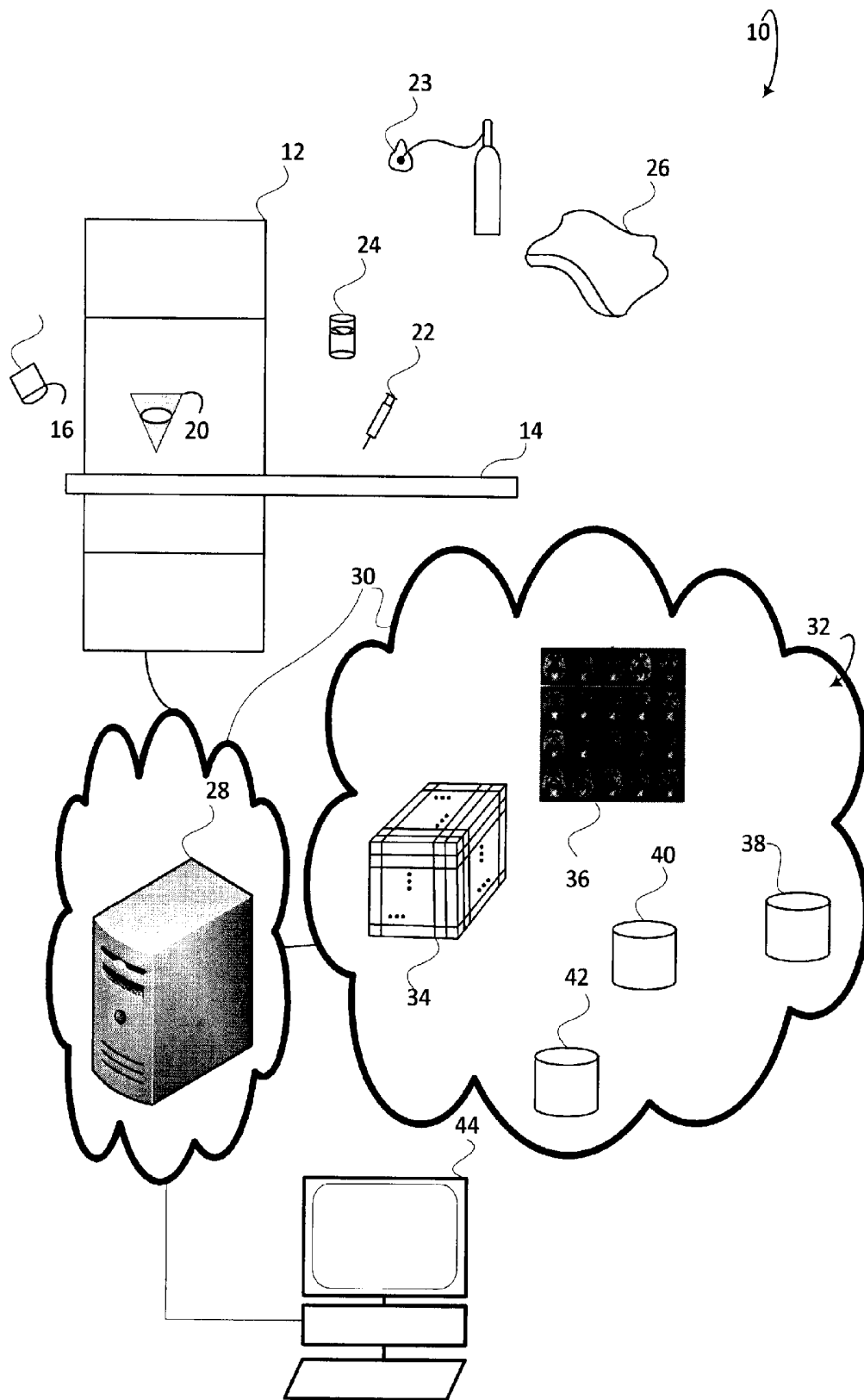

Figure 1

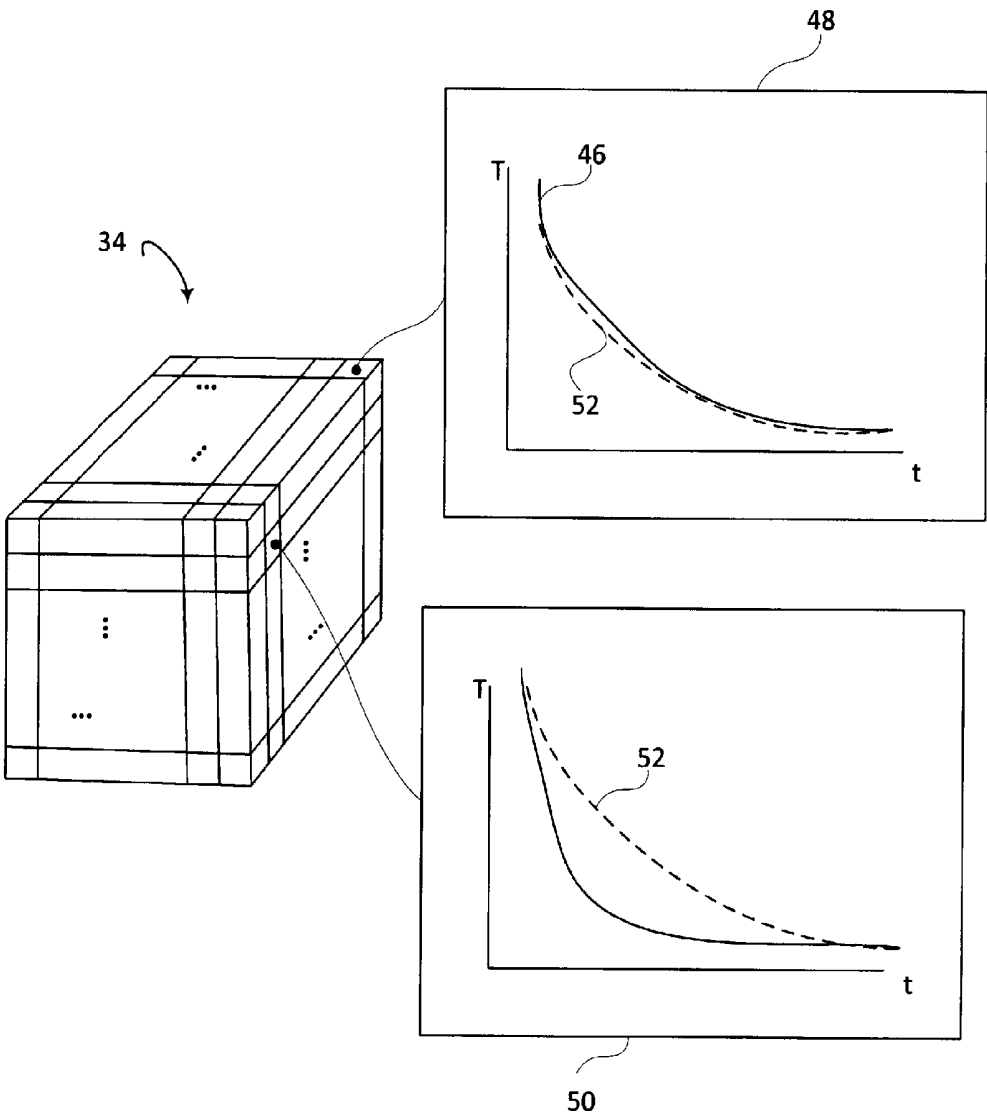

Figure 2

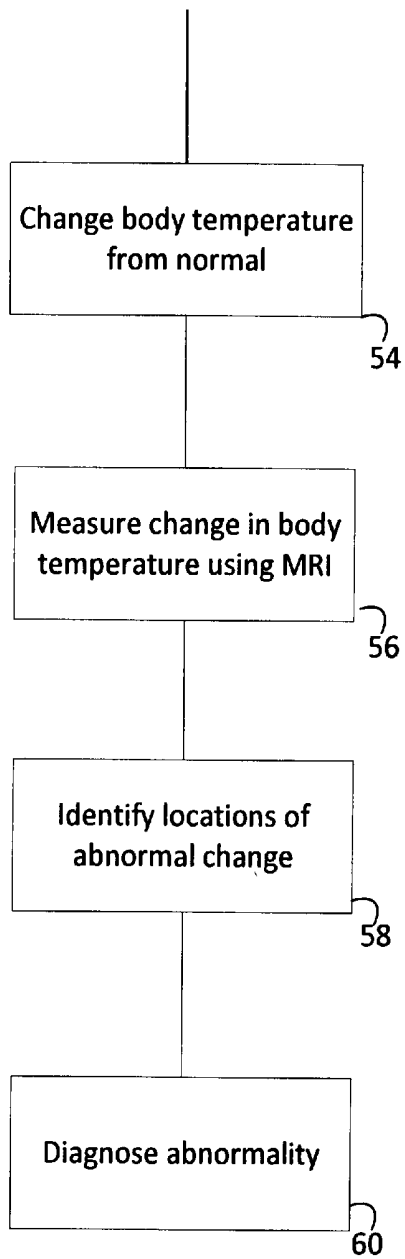

Figure 3

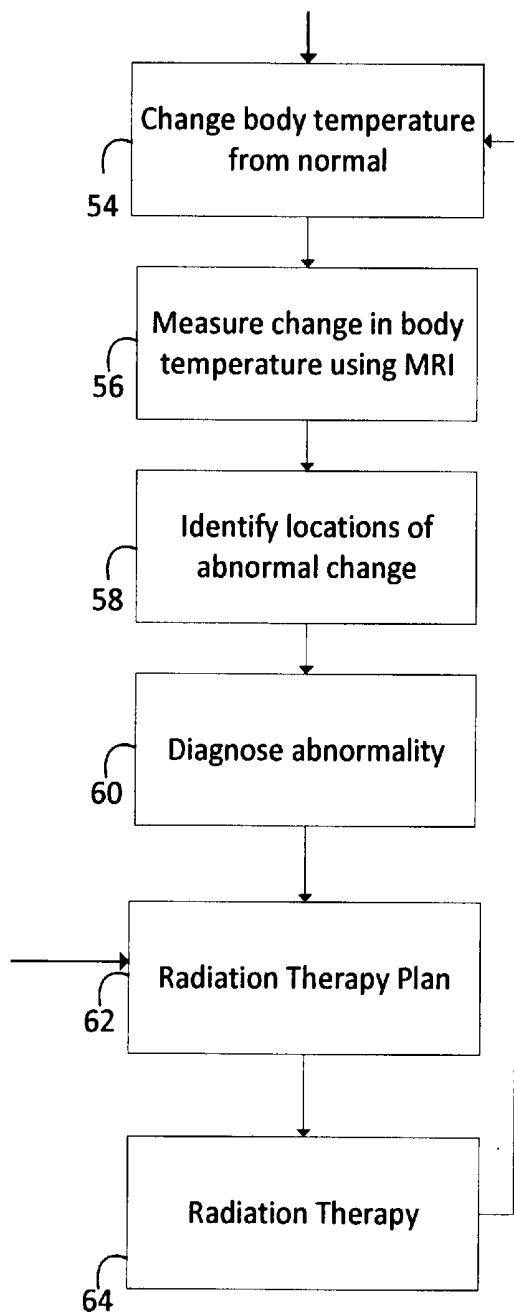

Figure 4

**MAGNETIC RESONANCE
THERMOGRAPHY: HIGH RESOLUTION
IMAGING FOR THERMAL ABNORMALITIES**

[0001] The present application relates generally to medical imaging. It finds particular application in conjunction with magnetic resonance imaging, and will be described with particular reference thereto. However, it will be understood that it also finds application in other usage scenarios and is not necessarily limited to the aforementioned application. Different diseases and/or injuries have been reported in the medical literature as exhibiting thermal properties. The diseases and/or injuries include Cancer, back injuries, breast disease, arthritis, inflammatory pain, nerve damage, vascular disease, digestive disorders, stroke screening etc. The thermal properties distinguish the diseased and/or injured tissue from normal tissue. For example, a tumor usually has more vascular circulation than normal tissue. Tissue which has more vascular circulation will cool more quickly than normal tissue when the body acts to restore homeostatic balance after heating. Similarly tissue which has more vascular circulation will heat more quickly than normal tissue when the body acts to restore homeostatic balance after cooling.

[0002] Measuring temperatures of diseased or injured tissue is typically done through surface measurements. One technique is Digital Infrared Thermal Imaging (DITI) which has been used since the 1980s. However, DITI can detect temperature changes only near the skin and not throughout the body. Magnetic resonance thermal imaging is the only currently known technique which is capable of measuring internal body temperatures without invasive procedures.

[0003] The present application discloses a new and improved Magnetic Resonance (MR) thermal imaging diagnostic method which addresses the above referenced matters, and others.

[0004] In accordance with one aspect, a magnetic resonance system includes a magnetic resonance scanner, one or more processors, and a display. The magnetic resonance scanner is configured for thermographic measurement. The one or more processors receive thermal image data from the magnetic resonance scanner and reconstruct at least one image in which each voxel of a region of interest includes a measure of temperature change. The one or more processors identifies thermally abnormal voxels. The display displays the at least one reconstructed thermal image with the identified thermally abnormal voxels.

[0005] In accordance with another aspect, a method of magnetic resonance thermography receives thermal image data from a magnetic resonance scanner and reconstructs at least one thermal image in which each voxel in a region of interest indicates temperature change. Thermally abnormal voxels are identified in the at least one thermal image.

[0006] One advantage resides in non-invasiveness of thermal imaging of interior portions of the subject.

[0007] Another advantage resides in the accuracy of magnetic resonance thermal imaging to measure abnormal thermal properties.

[0008] Another advantage resides in safe methods for heating or cooling target areas of the body.

[0009] Another advantage resides in using thermal information for more accurate diagnosis.

[0010] Another advantage resides in monitoring the effectiveness of radiation therapies.

[0011] Another advantage resides in combination with developing, updating, or refining radiation therapy plans.

[0012] Still further advantages of the present application will be appreciated to those of ordinary skill in the art upon reading and understanding the following detailed description.

[0013] The invention may take form in various components and arrangements of components, and in various steps and arrangement of steps. The drawings are only for purposes of illustrating the preferred embodiments and are not to be construed as limiting the invention.

[0014] FIG. 1 schematically illustrates an embodiment of a magnetic resonance scanner system with various devices for heating/cooling target areas of the subject body.

[0015] FIG. 2 schematically illustrates an example of one embodiment of a imaging volume and different voxel temperature (T) vs time (t) measurements.

[0016] FIG. 3 flowcharts an embodiment of the method for diagnostic identifying thermal abnormalities.

[0017] FIG. 4 flowcharts an embodiment of the system using in combination with radiation therapy planning.

[0018] With reference to FIG. 1, an embodiment of a magnetic resonance scanner system 10 with various devices for heating/cooling target areas of the subject body is schematically illustrated. A magnetic resonance (MR) scanner 12 is configured to generate magnetic resonance images indicative of the temperature of each voxel of a region of interest of the body. The MR scanner 12 is shown in a cross section with a patient support 14. MR scanners detect temperature changes as small as 0.1° C. Temperature changes to the body can be induced using a variety of techniques such as ultrasound, radio frequency (RF) pulses, ingested liquids, injected solutions, compresses, etc.. The temperature changes are caused by a variety of devices such as a ultrasound emitter 16, a RF emitter 20, a syringe of thermal/chemical solution 22, a vessel of thermal/chemical liquid to be consumed by the patient 24, a mask connected to a gas which is inhaled by a patient 25, a hot/cold compress 26, etc.. Temperature changes can also be natural such as due to exercise active or passive, and natural body temperature cycles which occur daily.

[0019] Thermal imaging data from the MR scanner 12 is transmitted to one or more processors 28 via a network 30. The processors can contain transitory and non-transitory memory. The network 30 includes a wired or wireless connection, a direct connect, or by a network connection such as a private network or the Internet. The processors can be contained within one server or across multiple servers.

[0020] A data storage 32 is attached to the one or more processors with a variety of different connection options. The data storage can be directly attached individual volumes, network attached storage, and the like. The data storage 32 provides storage for the received thermal imaging data 34, stored collectives of thermal images 36, diagnostic databases 38, and databases of radiation therapy plans 40 and treatment methods 42. The stored collectives of thermal images include images which represent a defined population. The defined population can be a normal population, which includes thermal images of normal images that voxel by voxel represent the variation of normal changes in temperature for healthy individuals. The normal collective can be compared with the thermal image voxel by voxel after registering to a common space and a probability that each thermal image voxel is different calculated. Alternatively, the collective can represent a diseased population(s) such as those with a vascular disease of the brain. The thermal image can be compared with

the collective to determine a probability that a voxel is similar to those found in the collective such as having vascular disease of the brain.

[0021] The diagnostic database includes diagnoses such as ICD-10, ICD-0, SNOMED, and the like. The diagnostic database includes morphology information and abnormal temperature change information. The diagnostic database enables cross reference of thermal abnormalities and possible diagnoses. The database of radiation therapy plans includes the steps and alternatives for treating a diagnosed condition. The treatment methods database includes parameters such as dosage and frequency of possible radiation therapies for diagnosed tumors, etc. The database of radiation therapy plans can extend beyond only magnetic resonance scanners, and include data concerning other devices typically used in conjunction or combination with magnetic resonance scanners such as Highly Focused Ultrasound (HIFU), LINear Accelerator (LINAC), X-ray and the like.

[0022] A display device **44** is connected to the network **30** and to the one or more processors. The display device **44** allows the healthcare practitioner to interact with the system. The display device can be a computer, laptop, tablet, mobile device, and the like. The display device displays the images, possible diagnoses, radiation therapy plans, image comparisons, and the like. For example, the thermal image of a back depicting the change in temperature in the daily temperature cycle is displayed. The magnitude in change in temperature at each voxel is displayed as a color based intensity. The intensity can be normalized using the collective and a back injury indicated by the voxels which deviate significantly from the normative population. Alternatively, the intensity can be normalized using the temperature of the pulmonary artery as a reference region where each voxel is the difference between the temperature at the voxel and the temperature of the pulmonary artery. The intensity of the voxel can be represented as an average of the difference, a minimum, a maximum or some function which includes the temperature of the reference region, and the change overtime. Other internal organs and regions are also contemplated. The display device **44** also inputs commands and permits the health practitioner to direct the use of the imaging system.

[0023] FIG. 2 schematically illustrates an example of one embodiment of a imaging volume and different voxel temperature measurements. The thermal imaging data **34** is shown as an example volume of voxels represented as a 3 dimensional rectangular volume. The volume of voxels can be any shape or dimension. Each voxel is repeatedly imaged over time to generate a temperature change overtime measurement either as a continuous measurement or discrete measurements using sampling techniques. For example, temperature measurements can be continuous based on the magnetic resonance imaging data as it becomes available from the scanner during the heating or cooling of the target area. Another example, temperature changes from the magnetic resonance scanner are measured at 1 minute or 10 minute intervals. An additional example, temperature changes are taken at morning, noon, and evening to compare daily temperature cycles. Analytics can be applied which fit functions to measurements in each such as curve fitting, discrete statistics, and the like. For example, as the number of sample points increase, regression techniques can be applied to fit a curve. Alternative examples include model curves based upon normal tissue temperature change which are adapted or modified as data points are obtained. The model curve can be a declin-

ing parabolic function for a decreasing temperature where the magnitude of the bend is adjusted to the sample points. Curve fitting includes moving averages, linear regression, and the like. Discrete statistics includes threshold, minimum, maximum, average, according to various distributions such as normal, Poisson, etc., and the like. The temperature change measurements can be increasing or decreasing depending upon whether heat or cold sources are applied to initially change the body temperature before measuring the temperature change as the body restores homeostatic balance. For example, the heat source such as less focused HIFU is initially applied to breast tissue to warm the tissue several degrees. The heat source is removed and the body cools the breast tissue. Tumors present in the breast tissue have greater vascular circulation and will show a steeper cooling curve. The increased blood circulated to the diseased tissue cools the diseased tissue more quickly. In the example measurements, the temperature change **46** is represented as a solid line curve or continuous measurement. The solid line curve can be based on sampling technique and curve fitting techniques described previously. The graph of one voxel temperature measurement illustrates a decreasing temperature which is normal **48** while another voxel illustrates an abnormal or more rapidly decreasing temperature **50**. In the example graphs, the more rapidly decreasing temperature curve is indicative of diseased tissue such as breast cancer.

[0024] The dotted line in the example graphs for two voxels are the expected temperature changes **52** for healthy tissue. The expected temperature changes **52** can be based on a variety of sources such as the collective **36**, a reference area of the patient, a baseline of the patient, an adjacent region of the patient, etc. Different parts of the body will change temperature at different rates. For example, tissue and organs in the torso will cool or heat more rapidly than extremities. The collective represents the variability of normal among a population, but does not represent normal for an individual patient. The reference area of the patient such as the pulmonary artery represents normal for the patient, but does not account for the variability between the different tissues or the impact of diseased tissue. The baseline for the patient can be where the patient has been a rest before heating or cooling of a target area. The baseline can alternatively be a temperature change curve of a region different from the region of interest. For example, a cold compress can be applied to a leg, removed, and the temperature change curve developed for voxels within the leg. A model change curve can be constructed using the temperature change curve from the voxels of the leg and applied as a baseline for temperature change curve measured for a different region of interest such as the breast. The baseline can be a function of an anatomical feature such as the brain, heart, etc., an average of the voxels of a target area, the body at rest responding to an artificial heat source before exercising and measuring the temperature change in comparison, and the like.

[0025] The measured temperature change **46** is compared with the expected temperature change **52** and the difference can be represented as a probability of an abnormality. The difference can be measured as the area between the dotting line curve and the solid line curve in the example. Alternatively, a maximum rate change of each curve can be measured and compared for a threshold value indicative of an abnormal thermal voxel. Various techniques can be applied to determine the likelihood of a difference between an expected and a measured temperature change. A probability map is

developed which includes the probability of a presence of an abnormality for each voxel. In another embodiment, the thermal curve of each voxel is compared with a series of curves, each curve associated with a diagnosis, e.g. a normal curve, a cancer curve, curves for different stages or types of cancer, arthritis, strains, inflammation and the like.

[0026] In FIG. 3 an embodiment of the method for diagnostic identification based on thermal abnormalities is flowcharted. In a first step 54, the body temperature is changed from normal or a baseline. The change can occur before or during the MR imaging sequence. Various devices as shown in reference to FIG. 1 can be used to elevate or decrease the body temperature of a target area. The body temperature can be elevated using active or passive exercise, natural body temperature daily cycles, and the like. The temperature of the target areas can typically safely increase 2-3° C. or decrease about 5° C. from normal which is easily sensed by MR thermography. For example, HIFU, which is used to kill diseased tissue internally in radiation therapy, can be less focused and used to heat the region of interest a few degrees. The magnetic resonance which is used to monitor HIFU therapies can also monitor the heating of a region of interest by HIFU for diagnostic purposes. Alternatively, if the digestive track includes the region of interest for example, then the patient can consume hot or cold water to heat or cool the digestive track. The liquid can be chemical based which temporarily elevates the body temperature as the chemical is absorbed. In another example, a saline solution can be injected which temporarily decreases the temperature of the blood. In another example, a cold gas can be inhaled which temporarily decreases the temperature of the pulmonary region. The gas can be thermally different to cause the thermal decrease or chemically based which cause the capillaries to dilate and lose heat during exhalation. In another example, exercise can raise the temperature of a region of interest through heat generated by muscle activity. Active patient exercise is exercise by the patient, wherein passive exercise is movement caused by another such as a physical therapist or electrical stimulation. Whatever form of exercise employed, muscle movement generates heat and the body will through homeostatis reduce the heat. Measuring the reduction in heat can be done easier when the body is at rest such as during imaging, and the cooling of muscle tissue produces measurable temperature changes.

[0027] The MR scanner measures the temperature changes in a step 56 as the body restores homeostatic balance, e.g. measures temperature repeatedly and generates a plot of temperature (T) vs time (t). The temperature can be measured with a thermal resolution of about 0.1° C. The measurement of temperature change was described in reference to FIG. 2. A probability map is developed in a step 58 which identifies a probability of abnormality at each voxel location. The locations including mapping to anatomical structures and/or regions of interest. The thermal curves can also be compared to reference thermal curves to determine a probability of a specific abnormality. For example, if maximum rate of temperature change for normal tissue is 0.3° C./min and the maximum rate of the thermal curve is 0.8° C./min, then there is a high probability that abnormal thermal tissue is present. The development of the probability map was described in reference to FIG. 2.

[0028] The mapped abnormal locations are correlated with possible diagnoses using the diagnoses database in a step 60. Other sources can be used such as other patient medical tests,

other patient images, and the like. For example, blood test indicating presence of certain types of tumors, x-ray images showing arthritis, etc. The possible diagnoses can be displayed to the healthcare practitioner with the MR images. The MR images can include the probability map of abnormal locations represented as different intensities. For example, voxels with high probabilities (e.g. >0.9) of thermal abnormalities can be shown in red, lower probabilities (e.g. >0.5) shown in yellow, etc..

[0029] The flowcharted embodiment uses a non-invasive method of MR thermography which identifies temperature abnormalities. The identified temperature abnormalities are used to identify possible diagnoses, or to provide information which can be correlated with other diagnostic tools and techniques.

[0030] In FIG. 4 an embodiment of the system and method used in combination with radiation therapy planning is flowcharted. The embodiment described in reference to FIG. 3 can be used to identify abnormalities. Other sources can be used and the system used to monitor the progress of a patient response to a radiation therapy. Thus, a radiation therapy plan can be generated in a step 62 or a next step in a progressive cycle of radiation therapy planning. The radiation therapy plan includes the initial size and location of a disease such as a tumor. The radiation therapy plan determines the manner and dose of radiation therapy such as with LINAC, HIFU, x-ray, and the like which is applied in a step 64. After radiation therapy is applied, the system measures the thermal temperature curve or change in the remaining target tissue, e.g. tumor. Changes in the thermal curve can be indicative of the relative success in killing tumor cells in each voxel. The system revises, updates, or refines the plan in accordance with the tumor destruction/survival as determined from the thermal curves.

[0031] It is to be appreciated that in connection with the particular exemplary embodiments presented herein certain structural and/or function features are described as being incorporated in defined elements and/or components. However, it is contemplated that these features may, to the same or similar benefit, also likewise be incorporated in other elements and/or components where appropriate. It is also to be appreciated that different aspects of the exemplary embodiments may be selectively employed as appropriate to achieve other alternate embodiments suited for desired applications, the other alternate embodiments thereby realizing the respective advantages of the aspects incorporated therein.

[0032] It is also to be appreciated that particular elements or components described herein may have their functionality suitably implemented via hardware, software, firmware or a combination thereof. Additionally, it is to be appreciated that certain elements described herein as incorporated together may under suitable circumstances be stand-alone elements or otherwise divided. Similarly, a plurality of particular functions described as being carried out by one particular element may be carried out by a plurality of distinct elements acting independently to carry out individual functions, or certain individual functions may be split-up and carried out by a plurality of distinct elements acting in concert. Alternately, some elements or components otherwise described and/or shown herein as distinct from one another may be physically or functionally combined where appropriate.

[0033] In short, the present specification has been set forth with reference to preferred embodiments. Obviously, modifications and alterations will occur to others upon reading and

understanding the present specification. It is intended that the invention be construed as including all such modifications and alterations insofar as they come within the scope of the appended claims or the equivalents thereof. That is to say, it will be appreciated that various of the above-disclosed and other features and functions, or alternatives thereof, may be desirably combined into many other different systems or applications, and also that various presently unforeseen or unanticipated alternatives, modifications, variations or improvements therein may be subsequently made by those skilled in the art which are similarly intended to be encompassed by the following claims.

1. A magnetic resonance system, comprising:
 - a magnetic resonance scanner configured for thermographic measurement;
 - one or more processors which:
 - receives thermal image data from the magnetic resonance scanner and reconstructs at least one thermal image in which each voxel of a region of interest includes a measure of temperature change; and
 - identifies thermally abnormal voxels in the thermal image;
 - a display which displays at least one reconstructed image with the identified thermally abnormal voxels.
2. (canceled)
3. The magnetic resonance system according to claim 1, further including:
 - a diagnostic database which stores at least temperature change measurements characteristic of at least one abnormal condition; and
 - wherein the processor further compares the measured thermal changes with the stored characteristic temperature changes.
4. The magnetic resonance system according to claim 1, wherein the one or more processors are further programmed to:
 - repeatedly reconstruct thermal images registered to a common space received over time; and
 - construct a thermal change curve which includes the period of at least one of heating and cooling.
5. The magnetic resonance system according to claim 1 further including:
 - at least one collective of thermal images which represents a normative population; and
 - wherein the one or more processors are further programmed to:
 - compare each voxel of the at least one reconstructed thermal image with the collective to identify differences.
6. The magnetic resonance system according to claim 3, wherein the diagnostic database links possible diagnoses with thermal abnormalities.
7. The magnetic resonance system according to claim 3, further including at least one device which increases the temperature and includes
 - an ultrasound emitter.
8. The magnetic resonance system according to claim 3, further including at least one device which decreases the temperature and includes at least one of the following:

- an injected chemical solution;
- an inhaled gas;
- an injected thermal/chemical liquid; and
- an externally applied cold source.

9. A method of magnetic resonance thermography, comprising:

- receiving thermal image data from a magnetic resonance scanner and reconstructing at least one thermal image in which each voxel in a region of interest indicates temperature change; and
- identifying thermally abnormal voxels in the at least one thermal image.

10. (canceled)

11. The method of magnetic resonance thermography according to claim 9, wherein the region of interest temperature change occurs by using at least one of:

- an ultrasound emitter;
- an externally applied thermal source;
- an inhaled gas;
- an injected thermal/chemical solution; and
- an injected thermal/chemical liquid.

12. The method of magnetic resonance thermography according to claim 9, wherein the magnetic resonance image data is obtained over a time interval to generate a thermal curve for each voxel.

13. The method of magnetic resonance thermography according to claim 12, wherein the thermal curve is generated during at least one of:

- while the temperature in the region of interest is being changed; and
- while the temperature in the region is recovering to a normal temperature after the temperature has been changed.

14. (canceled)

15. The method of magnetic resonance thermography according to claim 9, wherein determining the thermally abnormal voxels include:

- comparing the indicated temperature change in the voxels of the thermal image with an expected temperature change.

16. The method of magnetic resonance thermography according to claim 9, wherein the expected change is a function of at least one of:

- an average of a volume, region, or anatomical segment of the region of interest;
- a volume, region, or anatomical segment of the region of interest of a normative patient or patient collective;
- a volume, region, or anatomical segment in a region of interest for a baseline of an imaged patient.

17. (canceled)

18. The method of magnetic resonance thermography according to claim 9, further including:

- inputting the location of identified temperature change abnormalities to a radiation therapy plan; and
- assessing an effect of a radiation therapy based on the presence of temperature change abnormalities.

19. (canceled)

20. A non-transitory computer-readable medium encoded to control one or more processors to perform according to claim 9.

* * * * *

专利名称(译)	磁共振热成像：热分析的高分辨率成像		
公开(公告)号	US20140309519A1	公开(公告)日	2014-10-16
申请号	US14/368306	申请日	2012-12-13
[标]申请(专利权)人(译)	皇家飞利浦电子股份有限公司		
申请(专利权)人(译)	皇家飞利浦N.V.		
当前申请(专利权)人(译)	皇家飞利浦N.V.		
[标]发明人	HUANG FENG REYKOWSKI ARNE DUENSING GEORGE RANDALL		
发明人	HUANG, FENG REYKOWSKI, ARNE DUENSING, GEORGE RANDALL		
IPC分类号	A61B5/055 A61B5/00 A61N5/10 A61B5/01 A61N7/02		
CPC分类号	G01R33/4808 A61B5/015 A61B5/055 G01R33/4804 A61N7/02 A61B5/01 A61B5/7282 A61B5/742 A61N5/1048 A61B5/7275 G16H20/40 G16H30/40 G16H50/20		
优先权	61/580412 2011-12-27 US		
其他公开文献	US9872622		
外部链接	Espacenet USPTO		

摘要(译)

磁共振扫描仪 (12) 被配置用于地形想象。一个或多个处理器 (28) 从磁共振扫描仪接收 (56) 热图像数据并重建至少一个热图像，其中每个体素包括温度变化的量度。一个或多个处理器识别 (58) 热异常体素。显示器 (44) 显示具有所识别的异常热位置的至少一个重建图像。

