



(19) **United States**

(12) **Patent Application Publication**  
**Hua**

(10) **Pub. No.: US 2012/0046531 A1**

(43) **Pub. Date: Feb. 23, 2012**

(54) **INSERTION OF MEDICAL DEVICES THROUGH NON-ORTHOGONAL AND ORTHOGONAL TRAJECTORIES WITHIN THE CRANIUM AND METHODS OF USING**

<i>A61B 5/055</i>	(2006.01)
<i>A61B 6/03</i>	(2006.01)
<i>A61N 2/00</i>	(2006.01)
<i>A61N 7/00</i>	(2006.01)
<i>A61B 5/145</i>	(2006.01)
<i>A61B 5/1459</i>	(2006.01)
<i>A61B 5/03</i>	(2006.01)
<i>A61B 5/00</i>	(2006.01)

(76) Inventor: **Sherwin Hua**, Newhall, CA (US)

(21) Appl. No.: **13/318,462**

(22) PCT Filed: **Dec. 21, 2010**

(86) PCT No.: **PCT/US2010/061531**

§ 371 (c)(1),  
(2), (4) Date: **Nov. 1, 2011**

(52) **U.S. Cl. .... 600/317; 600/300; 607/116; 600/549; 600/476; 600/473; 600/459; 604/66; 607/96; 607/92; 607/89; 607/45; 606/129; 600/411; 600/427; 600/439; 600/9; 601/2; 600/310; 600/345; 600/309; 600/561; 607/48**

(57) **ABSTRACT**

The invention comprises an elongated device adapted for insertion, including self-insertion, through the body, especially the skull. The device has at least one effector or sensor and is configured to permit implantation of multiple functional components through a single entry site into the skull by directing the components at different angles. The device may be used to provide electrical, magnetic, and other stimulation therapy to a patient's brain. The lengths of the effectors, sensors, and other components may completely traverse skull thickness (at a diagonal angle) to barely protrude through to the brain's cortex. The components may directly contact the brain's cortex, but from there their signals can be directed to targets deeper within the brain. Effector lengths are directly proportional to their battery size and ability to store charge. Therefore, longer angled electrode effectors not limited by skull thickness permit longer-lasting batteries which expand treatment options.

**Related U.S. Application Data**

(60) Provisional application No. 61/288,619, filed on Dec. 21, 2009.

**Publication Classification**

(51) **Int. Cl.**

<i>A61B 5/01</i>	(2006.01)
<i>A61N 1/05</i>	(2006.01)
<i>A61B 6/00</i>	(2006.01)
<i>A61B 8/00</i>	(2006.01)
<i>A61M 5/168</i>	(2006.01)
<i>A61F 7/00</i>	(2006.01)
<i>A61N 5/06</i>	(2006.01)
<i>A61N 5/067</i>	(2006.01)
<i>A61N 1/36</i>	(2006.01)
<i>A61B 19/00</i>	(2006.01)

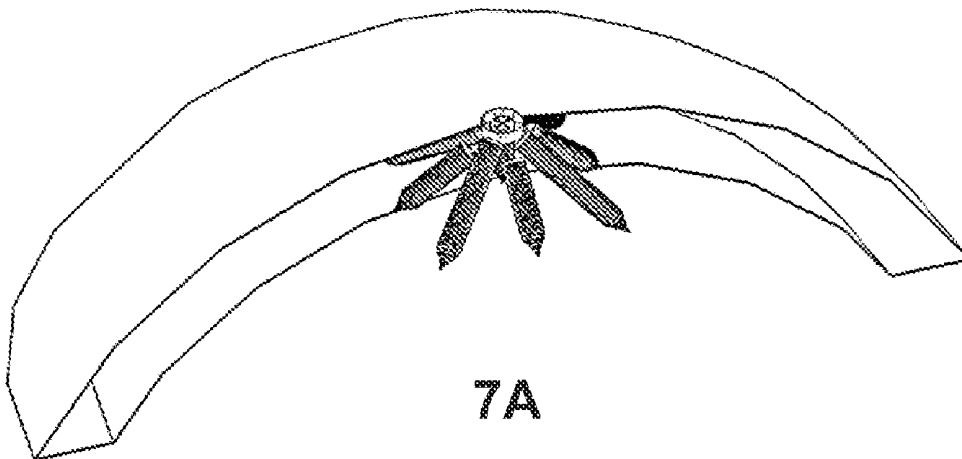
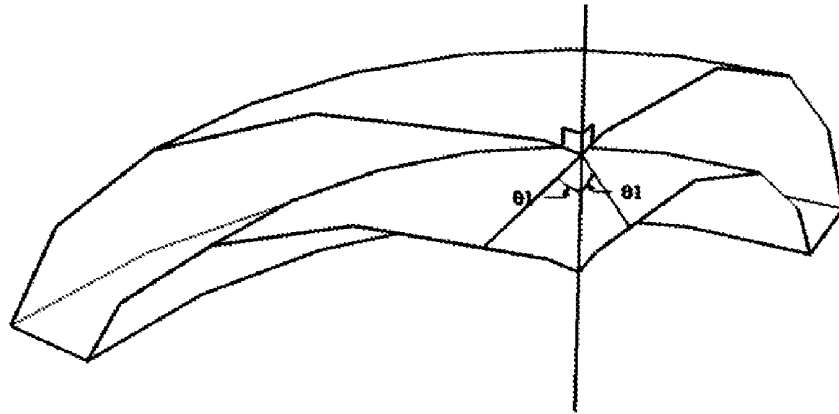
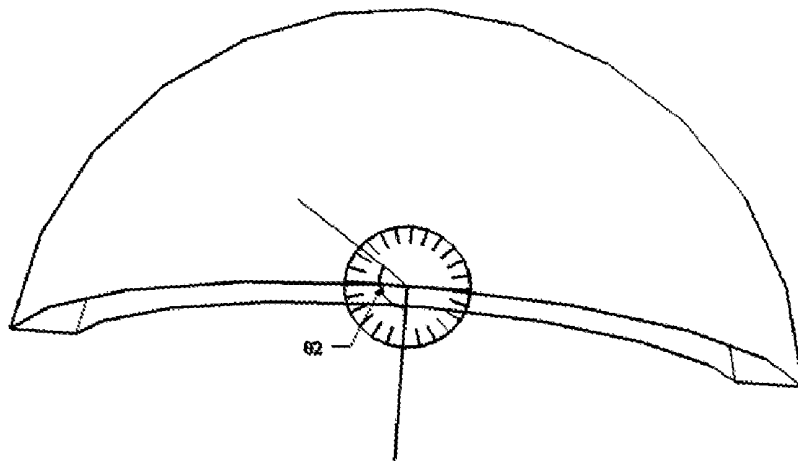


FIG. 1

1A



1B



**FIG. 2**

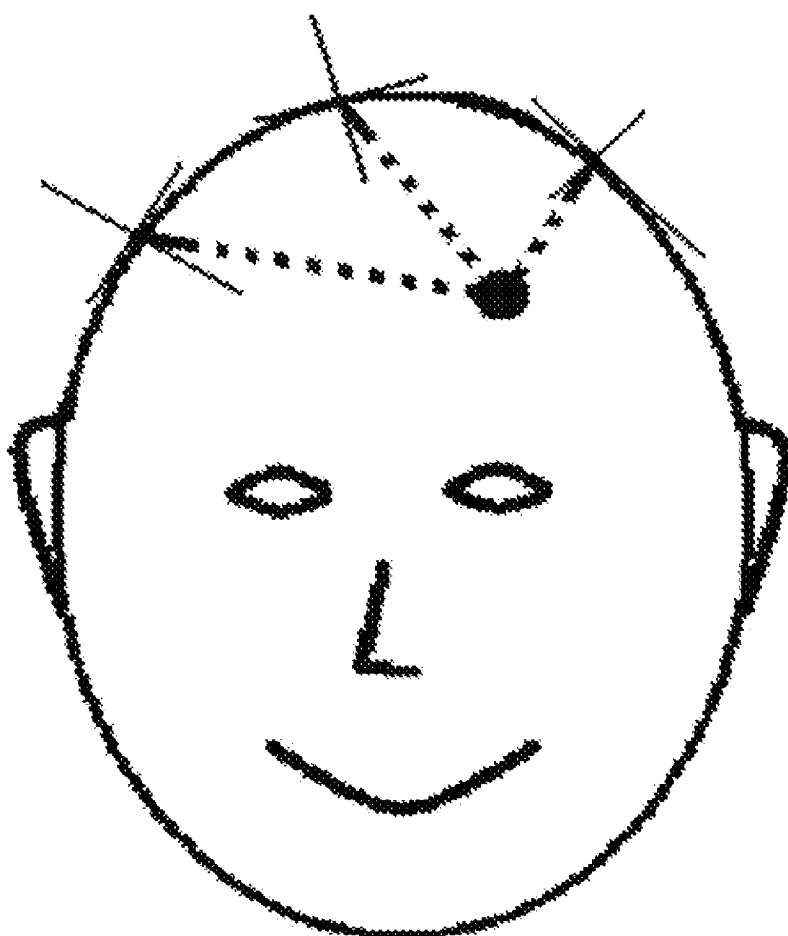


FIG. 3

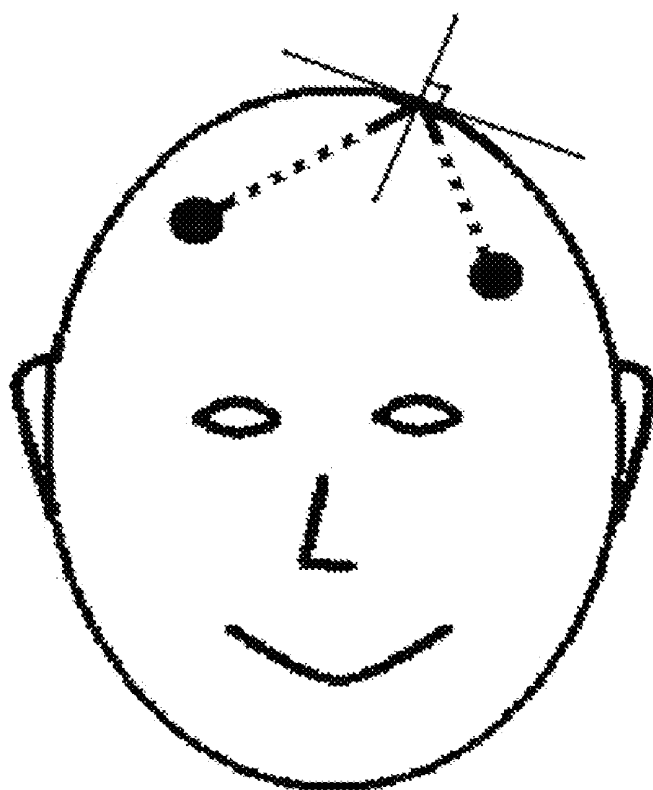


FIG. 4

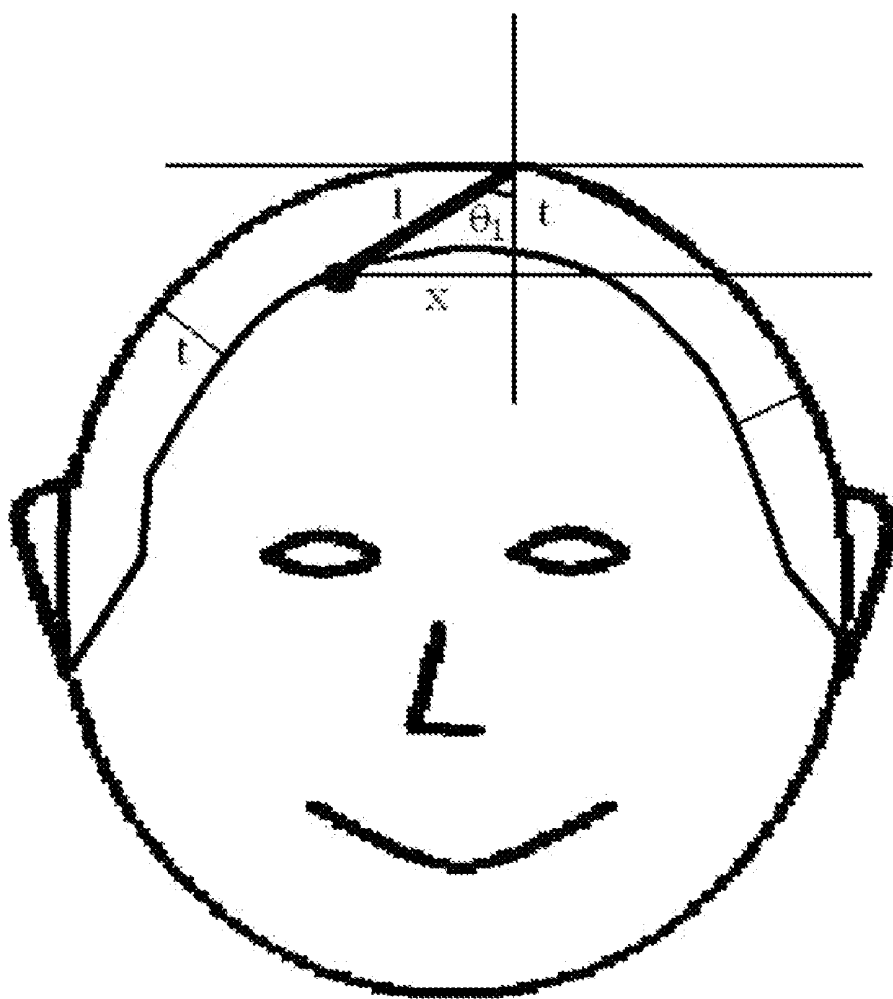
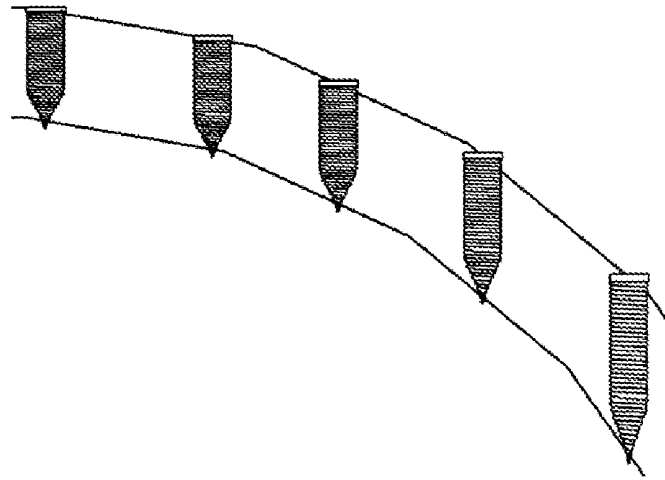


FIG. 5

5A



5B

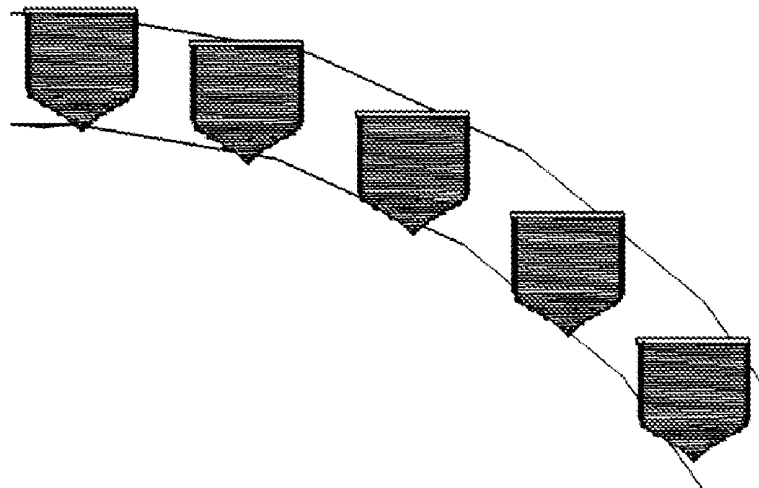
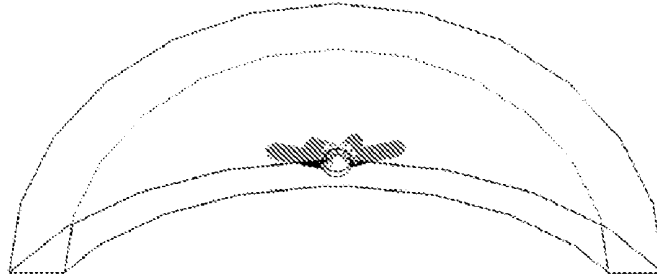
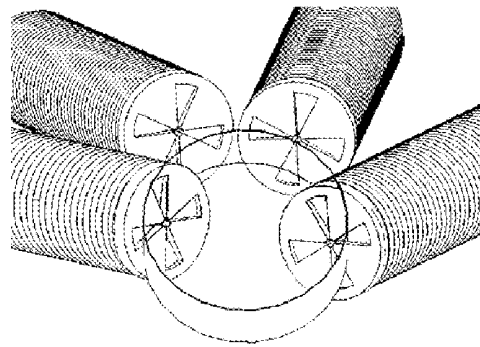


FIG. 6

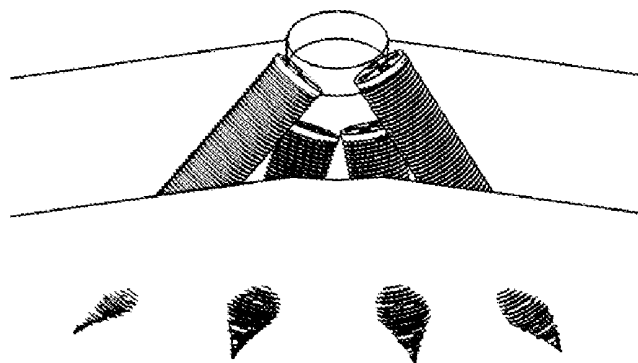
6A



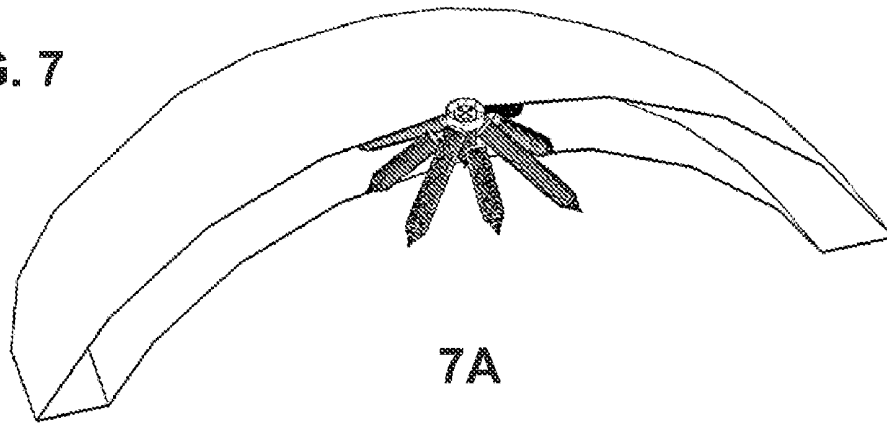
6B



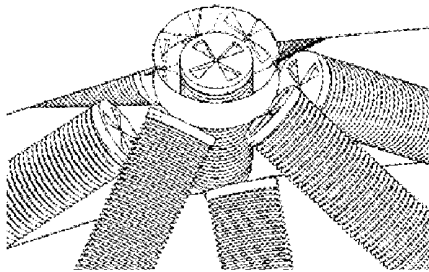
6C



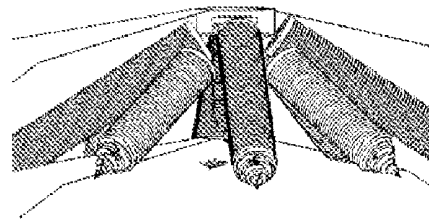
**FIG. 7**



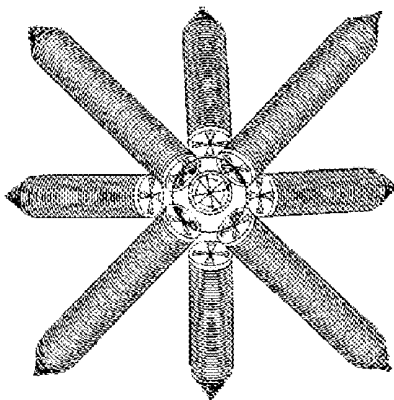
**7A**



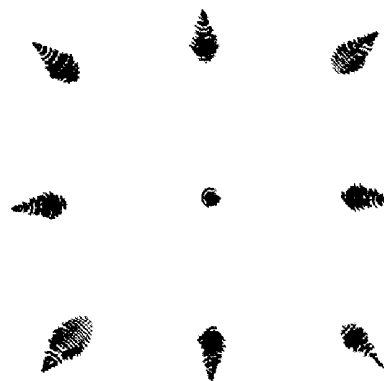
**7B**



**7C**

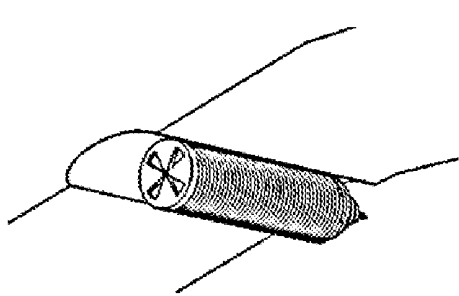


**7D**

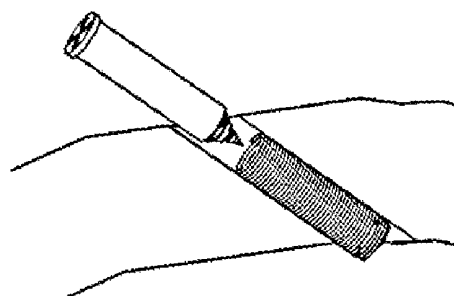


**7E**

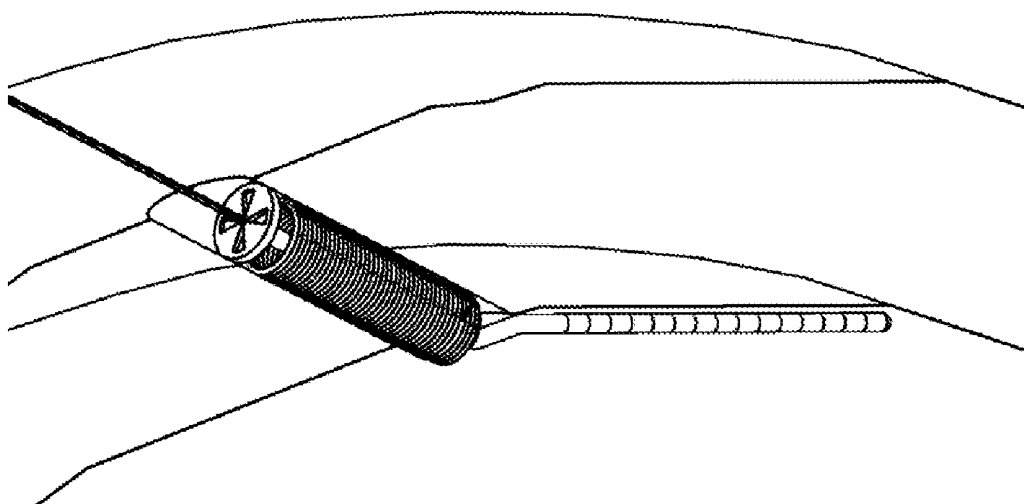
FIG. 8



8A

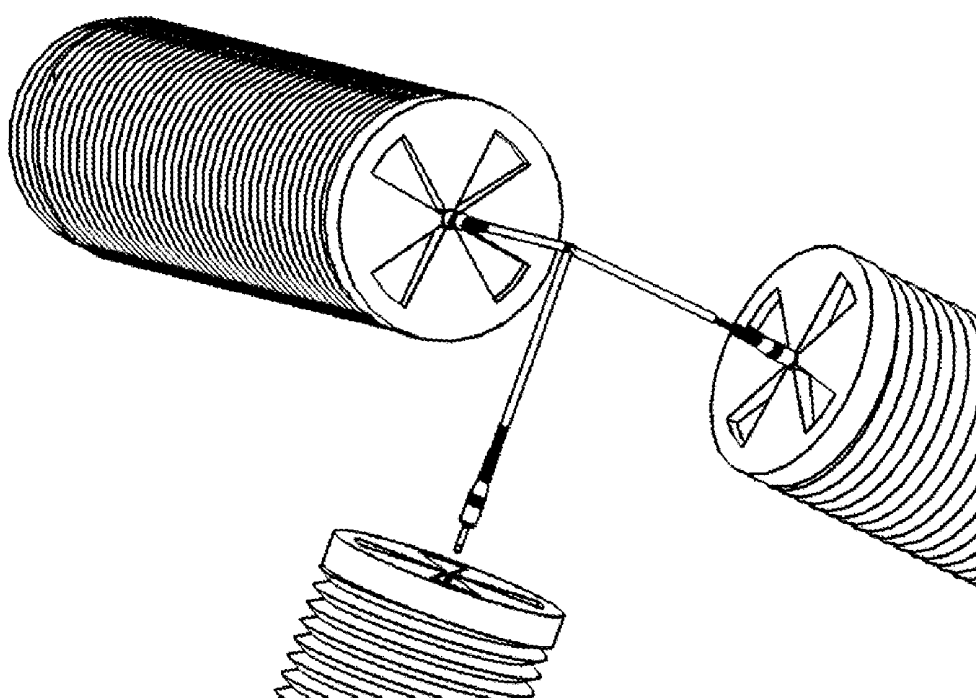


8B



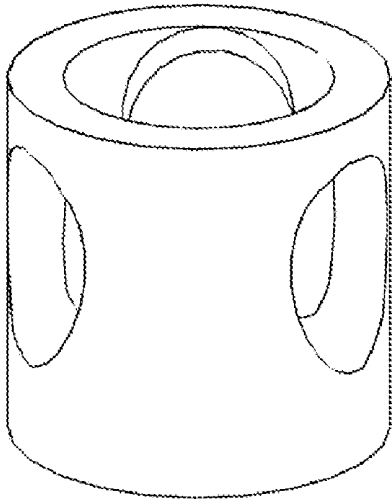
8C

FIG. 9

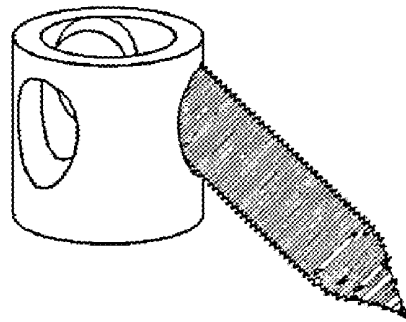


**FIG. 10**

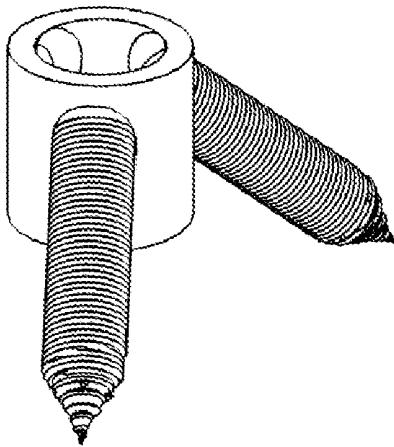
**10A**



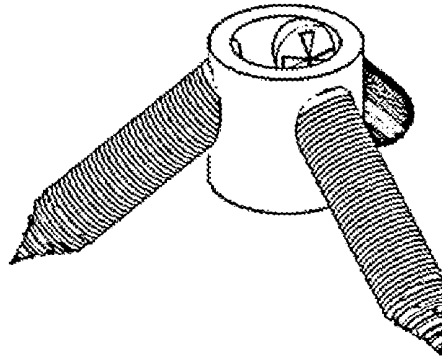
**10B**



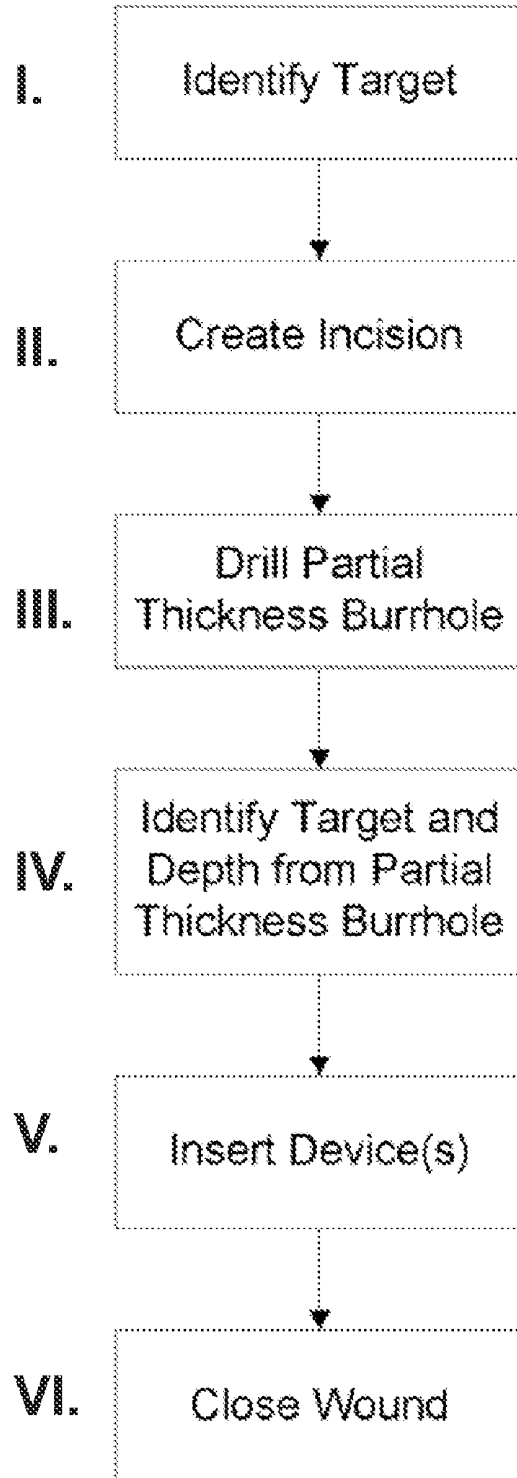
**10C**



**10D**



**FIG. 11**



**INSERTION OF MEDICAL DEVICES  
THROUGH NON-ORTHOGONAL AND  
ORTHOGONAL TRAJECTORIES WITHIN  
THE CRANIUM AND METHODS OF USING**

BACKGROUND

**[0001]** 1. Field of the Invention

**[0002]** The present invention relates to medical devices, systems and methods for accessing cranial and intracranial structures. Specifically, the invention is directed to altering brain function and treating cranial and intracranial pathology. More specifically, the invention is directed to the surgical implantation of electrodes or other devices within or through the cranium to alter or improve brain function and pathological states such as stroke, seizure, degeneration, and brain tumors. Most specifically, the invention is directed to minimizing surgical methods and risks and maximizing the length of devices that can be implanted within or through the cranium and their ability to hold charge.

**[0003]** 2. Description of the Related Art

**[0004]** Electrical stimulation of the brain can improve and ameliorate many neurologic conditions. Examples of the success of brain stimulation include deep brain stimulation for Parkinson's Disease, tremor, dystonia, other movement disorders, epilepsy, and pain. Additionally, potential new sites of deep brain stimulation demonstrate promising results for other conditions such as obesity, depression, psychiatric disorders, memory, migraine headache, and minimally conscious states.

**[0005]** Deep brain stimulation involves placing a long electrode through a burrhole in the cranium to a target deep to the surface of the brain. The electrode is placed under stereotactic guidance which is performed with or without a frame. Frame based systems such as the Leksell frame require that a rigid stereotactic frame is clamped to the skull through a number of screws that are fixed to the cranium. Frameless systems utilize fiducial markers placed on the skin. In both methods, an MRI (magnetic resonance imaging) or CT (computed tomography) scan is performed with the frame or fiducial markers in place. In frame based stereotaxy, computer assisted reconstruction of the brain and target area is performed to localize the target in relation to the coordinates of the frame. In frameless stereotaxy, a three-dimensional reconstruction of the cranium and brain is matched to the three-dimensional configuration of the fiducial markers. The end result in both cases is the ability to place electrodes accurately into virtually any part of the brain.

**[0006]** The cerebral cortex is another structure that yields a large potential for therapeutic intervention. In deep brain stimulation, the electrode passes through the cerebral cortex as well as subcortical brain structures to reach the affected deep brain nuclei and therefore risks injury to the intervening healthy brain tissues as well as blood vessels. These unnecessary yet unavoidable injuries can potentially result in loss of brain functions, stroke, and intracranial hemorrhage. On the other hand, stimulation of the cerebral cortex is safer because electrodes are placed on the surface of the brain or even outside the covering of the brain, i.e. dura mater, a technique called epidural electrode stimulation. Additionally most of the subcortical or deep brain structures have connections with known targets in the cortex, making these targets candidates for cortical stimulation. Accordingly, directly stimulating the cortex can affect subcortical and deep brain structures that directly or indirectly communicate with the cortical targets.

Previous studies have demonstrated success in using cortical stimulation for the treatment of epilepsy, stroke rehabilitation, pain, depression, and blindness.

**[0007]** In addition to the treatment of pathologic conditions, brain stimulation and recording provides the virtually unlimited potential of augmenting or improving brain function. These technologies allow the brain to bypass dysfunctional neural elements such as due to spinal cord injury, amyotrophic lateral sclerosis (ALS), stroke, multiple sclerosis (MS), and blindness. Brain recording and stimulation techniques in these cases provide a bridge for neural signals to cross injured or dysfunctional elements both on the input as well as the output side. For example in the case of ALS or a patient with locked-in syndrome, the patient is awake and conscious but without any ability to interact with the environment. These patients are essentially trapped within their brain. Recently, it has been demonstrated that by placing recording electrodes directly on the surface of the brain, these patients can learn to control computer cursors and other devices through their own brainwaves. This method of direct control of external devices through brainwaves is called brain-machine interface

**[0008]** Brain-machine interface has also been implemented using brainwaves recorded outside the cranium—electroencephalography (EEG), which detects the neural signals passing through the cranium with electrodes placed on the scalp. Although noninvasive, brain-machine interface using EEG signals is currently limited from the significant dampening of the brainwave's amplitude by the cranium. Only the largest potentials among the brain signals are detectable by the EEG approach.

**[0009]** Similarly the cortex and some subcortical fibers can be activated through the cranium by transcranial magnetic stimulation (TMS) or transcranial direct current stimulation (tDCS). In this approach, magnetic waves (TMS) or electrical currents (tDCS) are activated on the scalp outside the cranium and transmitted through the cranium to activate parts of the cortex and subcortical fibers. TMS has been effective in treating a number of disorders such as depression, migraines, and movement disorders. Additionally some reports suggest that TMS may be able to boost memory and concentration. Similarly tDCS appears to improve some forms of learning when applied in low doses. This evidence suggests that stimulation of the cortex may have a large, virtually unlimited, variety of applications for treating central nervous system pathology as well as enhancing normal brain functions.

**[0010]** Electrical stimulation has also been applied effectively for the treatment of certain tumors. By applying an electrical field that disrupts the physiology of tumor cells, tumors have been found to shrink. Tumors in the brain, particularly those close to the surface of the brain such as meningiomas may also be treated by electrical stimulation. In addition to electrical fields, heat (thermoablation) and cold (cryoablation) have also demonstrated effectiveness towards tumors.

**[0011]** Prior art and current state of the art for brain stimulation technologies require the placement of electrodes either through a craniotomy where a flap of the skull is removed and then replaced, or a burr hole where a small hole is drilled in the skull and the brain can be visualized. These procedures necessitate a minimum of an overnight stay in the hospital and pose risk to injury of the brain due to the invasiveness of the techniques. Additionally these "open" techniques pose special challenges for securing the electrode as most technolo-

gies require a lead to exit the hole in the skull. Unless these electrodes are tethered by a suture or device, there is possibility of migration or movement, particularly in the context of continuous pulsatile movement of the brain in relation to the skull.

**[0012]** Current techniques for cortical stimulation also risk the development of scarring of the cortex as well as hemorrhage. With long term placement of foreign objects on the brain or spine, scarring (gliosis and inflammation) occurs. This is seen with both spinal cord stimulators placed on the spinal cord as well as prostheses placed on the surface of the brain. Scarring distorts the normal brain architecture and may lead to complications such as seizures. Additionally, the placement of devices on the surface of the brain poses risks of hemorrhage. A previous clinical case illustrates the dangers: a patient who received subdural cortical electrode implantation suffered significant intracranial hemorrhage after suffering head trauma. Thus in the case of a deceleration injury like that seen in traffic accidents or falls, the imperfect anchoring of the electrode and the mass of the electrode may cause the electrodes to detach and injure the brain. Blood vessels also can be sheared from the sudden relative movement of the electrode on the brain, leading to subdural, subarachnoid, and cortical hematomas. However, if the electrodes were embedded within the skull then there is no risk of this type of shearing injury during traumatic brain injury such as from sudden impact accidents.

**[0013]** In order to expand the indications of brain stimulation to a larger population of patients, the invasiveness of techniques for placement of the electrodes needs to be minimized. As many surgical specialties have demonstrated, minimized surgical approaches often translate into safer surgeries with shorter hospital stays and greater patient satisfaction.

**[0014]** Recent advances in the miniaturization of microelectronics have allowed the development of small, completely contained electrode systems, called the bion, that are small enough to be injected into muscle and other body parts through a syringe. This type of microelectrode device contains stimulation and recording electrodes, amplifier, communication, and power components all integrated into a hermetically sealed capsule. While some bion devices have batteries integrated with the unit, others are powered by radiofrequency transmission. Although muscle and other body parts allow the implantation of bion electrodes, the cranium poses a challenge to the bion because the cranium is roughly 1 cm or less in thickness. This finite thickness limits the size of the electronic components as well as the size of the battery. Battery capacity (the amount of energy stored within the battery) determines the length of time between charges in a rechargeable battery and is effected by the length of the battery. In the case of the bion, an injectable device that demands a small diameter, the battery capacity is directly related to the length of the battery. A longer bion electrode permits a longer battery and hence greater battery capacity and a longer run time without recharging.

**[0015]** Some patents exist covering implantable stimulators and electrical stimulation therapy systems. However, these patents are not specially adapted for insertion through the skull with multiple components through a single site by means of introducing some components at non-orthogonal angles.

**[0016]** For example, U.S. Pat. No. 5,324,316 entitled "Implantable microstimulator" by Joseph H. Schulman, et al. and assigned to the Alfred E. Mann Foundation For Scientific

Research (Sylmar, Calif.) discloses an implantable stimulator with electrodes inside a hermetically-sealed housing that is inert to body fluids. The electrodes receive energy from a capacitor that stores energy and includes a coil transformer which, in turn, receives energy from an alternating magnetic field. The patent discloses "[t]he microstimulators, of course, may be planted in or near any part of the body, in the brain, a muscle, nerve, organ or other body area" (See 4:24-26) However, no details are provided on how the microstimulators would be or could be implanted into the brain. The presumption would be that this is done according to conventional ways such as by introducing traditional long electrodes through burr holes. There is no mention of insertion through the skull or cranium. The patent emphasizes the stimulators are implanted by "expulsion through a hypodermic needle" (Abstract, 1: 13-15, 2:7-10, 2:35-37, etc.). Certainly a hypodermic needle cannot be injected through the skull which suggests these stimulators are not designed for such a purpose. Further, there is no disclosure of multiple interconnected components through a single entry site by insertion of some components at non-orthogonal or diagonal angles. The hermetically sealed housing inert to body fluids would prevent the microstimulators from hard-wired communication with one another and from sharing power through hard-wired connections with other units. Thus, in the system of U.S. Pat. No. '316 each microstimulator is essentially its own physically isolated entity interacting with and charged by an external magnetic field but not interacting with the other microstimulators except through wireless communication.

**[0017]** U.S. Pat. No. 6,208,894 entitled "System of implantable devices for monitoring and/or affecting body parameters" also by Joseph H. Schulman, et al. and also assigned to the Alfred E. Mann Foundation For Scientific Research (Sylmar, Calif.), as well as Advanced Bionics, Inc., discloses a system control unit (SCU) and one or more other devices designed to be "implanted in the patient's body, i.e., within the envelope defined by the patient's skin" rather than through the skin and/or through the skull. In the present invention the skull rather than the skin defines the envelope. The SCU wirelessly communicates with the various addressable devices and in some cases the addressable devices wirelessly communicate with one another (7:50). In the present invention, the interconnection of multiple devices at the insertion point permits several devices to communicate directly (even in the absence of an intermediary SCU) and through direct contact (which may be more reliable than wireless). U.S. Pat. No. '894 does not refer to the skull or cranium. U.S. Pat. No. '894 refers to sensing signals originating from or generated by a patient's brain (2:44-48, 1 1:3-6) but does not disclose that any of the devices are actually inserted into the brain or on its surface (epidurally). Rather, it appears the devices are implanted past sites of nerve damage and used to replace damaged nerves (2:40-52).

**[0018]** Advanced Bionics, Inc. has several of its own microstimulator "system" patents. For example, see U.S. Pat. No. 6,181,965; U.S. Pat. No. 6,175,764; and U.S. Pat. No. 6,051,017. These patents also disclose implantable microstimulator systems with hermetically sealed housings and configured for implantation through a hollow cannula. The electrodes protrude from the housing. Additionally, the housing has a polymeric coating that may contain a chemical or pharmaceutical agent for providing drug therapy simultaneous with electrical stimulation. There is no mention of the skull or cranium and the brain is referred to only in the background discussion with

respect to the communication of signals from the brain and loss of voluntary muscle function from injury to the brain.

**[0019]** Advanced Bionics, Inc. also has various other “method” patents that specifically refer to brain stimulation through the implantation of a system control unit and electrode in the brain (see for example, U.S. Pat. No. 7,151,961; U.S. Pat. No. 7,013,177; and U.S. Pat. No. 7,003,352.) These patents emphasize method claims. The implantable micro-stimulator SCU/electrode systems disclosed therein are similar and the methods apply to the many applications for such systems. The methods require the control unit to be implanted “entirely within the brain” (vs. on the surface or external to the body) (see U.S. Pat. No. ’961 claim 1 and U.S. Pat. No. ’177 claim 28) and emphasize drug delivery from a pump and infusion outlet coupled with or as an alternative to electrical stimulation. The patents do refer to the “skull” in the context of “implanting . . . in at least one of the skull and the brain” (see U.S. Pat. No. ’177 claims 1, 14, 19, 23). There is no disclosure of multiple components through a single entry site or non-orthogonal/diagonal/radial angles of insertion.

**[0020]** Vertis Neuroscience, Inc. has two patents that discuss insertion angle control and depth control of an electrode. However, neither patent teaches or suggests incorporating the electrode in a screw housing or other component capable of penetrating the skull or cranium (rather than just the skin) for access to the brain’s cortex. There is no teaching of applying angle and depth control in order to fit more than one electrode through a single entry site. FIG. 10-11 show multiple entry sites with a separate spot for each electrode.

**[0021]** U.S. Pat. No. 6,622,051 entitled “Percutaneous electrical therapy system with electrode entry angle control” by Jon M. Bishay, et al. discloses an electrode with a sharp tip and a device for controlling the angle of entry of the electrode through tissue. There is no mention of non-orthogonal or diagonal angles of insertion in order to fit more electrodes or other components through the same entry site. The angle of entry control assembly is used to control where the sharp point on the tip of the electrode will ultimately end up in order to refine localized electrical stimulation therapy. The electrodes are dispensed from an introducer with springs similar to the expulsion methods through needles and cannulas as disclosed in the Alfred Mann and Advanced Bionics patents. Multiple electrodes may be arranged radially about a hub and dispensed from the same introducer (10: 17-27). However, there is no disclosure of inserting multiple electrodes through the same entry site. The introducer could be moved to insert the various electrodes in different chambers at different locations.

**[0022]** U.S. Pat. No. 6,549,810 entitled “Percutaneous electrical therapy system with electrode depth control” by Paul Leonard, et al. is similar to U.S. Pat. No. ’051 but also uses a depth control assembly to direct positioning of the sharp tip of the electrode within tissue, in addition to the angle control assembly. The depth control assembly includes an actuator and a limit stop. In the present invention the length of the electrode can be used to determine its optimal angle of insertion so that electrode length equals length through the skull. This permits the electrode to just exit the skull and terminate at the brain’s cortex, balancing maximum effectiveness with minimal invasiveness. Thus, electrode length is fixed and taken into account to determine the angle so that when the electrode is inserted (an actuator not being necessary to do this) it can be inserted all the way without need for a limit stop.

**[0023]** In both Vertis patents the electrode communicates electrically with a transmitting control unit. There is no disclosure of the electrodes themselves being used to transmit.

**[0024]** NeuroPace, Inc. has patents (i.e. U.S. Pat. No. 6,016,449) on implantable systems where the control module is placed in the cranium but requiring either additional burr holes or openings in the cranium for the stimulating electrodes to enter the cranium. These designs are significantly more invasive than having just one opening in the cranium and continue to carry the risk of electrodes moving with respect to the brain during head injuries.

**[0025]** In the present invention an electrode can communicate with and work together with other electrodes and supporting components (i.e. receivers, transmitters, batteries, rechargers, etc.) for an integrated therapy system with multiple components insertable through the same

#### BRIEF SUMMARY OF THE INVENTION

**[0026]** The invention involves an improved method of implanting effectors, sensors, systems of effectors and sensors, and other implantable medical devices into the body through skin, bone, muscle, tissue, and other intermediary material between an external surface of the body and the intended physical contact. The physical contact within the body may be the target from which information is gathered with the sensors or to which energy is directed with the effectors. Alternatively, the physical contact may be a transceiver station from which information is received by the sensor from another target (deeper inside) or from which energy is sent by the effectors to another target (deeper inside). When implanted into the cranium the devices of the present invention described herein are referred to as a Cranion™.

**[0027]** The effector may include any component that produces or induces an effect or acts as a stimulus at a target within the body. A preferred example of an effector is an electrode producing an effect through electricity. Other types of effectors produce effects using magnetism, temperature, infrared radiation, light, vibrations, hypersonic energy (frequencies above human hearing), ultrasonic energy, radio-waves, microwaves, etc. and include transmitters of these other forms of energy.

**[0028]** The sensor may receive and record data relating to temperature, light, density, impedance, etc., in the form of radiowaves, microwaves, spectroscopy, etc.

**[0029]** According to a preferred embodiment, the invention focuses on improved devices and methods for implantation through the cranium to provide brain therapy and therapeutic treatment of medical conditions having a neurological component.

**[0030]** The improved method involves modification of implantable devices to specific sizes and shapes so that one or several can be inserted simultaneously through a single entry site in the cranium by altering the insertion angle of each unit. The individual units are inserted orthogonally and/or non-orthogonally relative to the surface of the cranium tangent to the singular common entry site. The individual units may be physically connected through a connector head at the common entry site, thereby sharing electronics, power, and other attributes. Additionally, in some embodiments, the distal tip of the shaft and the shaft of the device may be configured so that the devices are insertable directly. By insertable directly it is meant that no or few other tools or instruments are needed to make the entry site and/or the hole through which the

implanted device is inserted. For example, the device may be encapsulated in a helical externally threaded screw housing such that the shaft has a sharp distal tip allowing the whole device to pierce through the skin and screw into bone similar to currently used self-drilling cranial plating screws. The self-inserting characteristic enables electrodes to be inserted almost anywhere very quickly in a minimally invasive screw-in or pop-in procedure.

**[0031]** The types of medical devices that can be modified and implanted by the methods described in this invention are virtually unlimited and include neural stimulation systems, neural recording systems, brain machine interface systems, cryotherapy systems, thermotherapy systems, magnetic field generating systems, radiation emitting systems, auditory systems, iontophoresis systems, interpersonal communication systems, interorganism communication systems, et al. Currently, electrodes placed on or near the surface of the brain have been used clinically to treat a number of disorders including seizures, pain syndromes, movement disorders, psychiatric disorders, paralysis, and neurodegenerative disorders like ALS. One preferred embodiment of the invention is to implant one or more cortical stimulation and recording electrodes close to the surface of the cortex through a single minimally invasive cranial entry site while enhancing the battery life and complexity of each electrode unit by allowing each unit to be greater in size (particularly length) than the thickness of the skull since they are adapted for insertion at an oblique angle and not limited to perpendicular insertion. However, consistent with the present invention, some electrodes (or other effectors) can be also be equal to or shorter than the thickness of the skull. Multicomponent devices and systems of devices with shorter electrodes (or other components) adapted for insertion of shafts at a variety of angles permits more components than previously possible through a single entry site. The electrodes may take the form of an implantable microstimulator or improved bion that is embedded in the skull with its tip placed either epidurally (upon the dura mater) or subdurally (below the dura mater) near the surface of the brain.

**[0032]** The thickness of the cranium is limited to a length of 5 mm to 10 mm. If electrodes are inserted straight down, perpendicular (orthogonal) to the surface of the cranium, their lengths would be limited to a maximum of approximately 1 cm. Electrodes longer than 1 cm that are implanted in the cranium orthogonally would protrude through the skull into the brain. Placement of electrodes into brain substance increases the risk of injury to brain and blood vessels both during the time of placement as well as afterwards given the physiologic pulsation of the brain in relation to the cranium as well as during episodes of head trauma which causes acceleration and deceleration movement of the brain in relation to the cranium. Current methods of cortical stimulation place electrodes either epidurally (outside the dura mater) or subdurally (in between the dura mater and arachnoid or epi-arachnoid). Placement of electrodes in either of these locations provides for low impedance stimulation of the brain while maximizing safety. Current methods of placement of cortical electrodes necessitates drilling of a burr hole or craniotomy, both of which pose risks to the patient and commonly require a stay in the intensive care unit to monitor postoperatively.

**[0033]** The current invention describes the method of insertion of devices and electrode units through orthogonal and nonorthogonal trajectories through the cranium. Angled

insertion of the electrode units enables longer units (length greater than skull thickness) to be used without penetrating into the brain. The angled electrodes pass almost entirely through the skull and then just barely protrude towards cerebral cortex. Longer electrodes units are desirable because the length of a battery is proportional to the size and capacity of the battery. Thus longer electrode units can contain longer and larger batteries. Preferably, the batteries are rechargeable. However, regardless of whether the batteries are rechargeable, it is desirable for the stimulation electrodes to have a maximum battery capacity (time until replacement or recharging). Higher capacity batteries provide sustained therapy and enhance patient mobility and freedom. The greater mobility and freedom provided by higher capacity batteries in longer electrodes increases the probability of patient compliance for out-patient procedures because it is easier to comply with prescribed therapeutic regimens while living a normal life.

**[0034]** Longer electrodes units also allow more components to be integrated within each implant. Larger size allows flexibility in terms of the complexity of the circuitry, communication components, as well as the inclusion of both recording (receiving) and stimulation (transmitting) capabilities. Additionally, multiple electrode contacts can be placed within a single implant with greater ease, i.e. bipolar, tripolar, tetrapolar stimulation or recording within each electrode unit.

**[0035]** The ability to insert several electrodes units through a single cranial entry site is highly advantageous. The cranium obviously provides an important protective function for the brain. Accordingly, it is desirable to keep the cranium as intact as possible while accessing the brain for therapy. Fewer entry sites in the cranium preserve its integrity and reduce the likelihood of the brain inadvertently being exposed or harmed. However, if fewer entry sites imply fewer electrodes this may have drawbacks with respect to the variety and intensity of therapy that can be provided. The ability to insert several electrodes through a single site provides powerful therapy without jeopardizing the cranium and more importantly, the brain and blood vessels beneath. When more intense therapy is not needed, multiple electrodes in the same region may still have advantages because they can be selectively, individually activated to prolong the time until recharging. For example, with electrodes radiating outward in a circle from a common insertion point, when the battery of the first electrode dies the system can automatically or manually advance to turn on the next electrode for it to begin stimulation. Additionally multiple electrodes positioned in a spatially dispersed pattern in two or three dimensional space allows the stimulating current to be steered in that space. Current steering has been utilized in spinal cord stimulation and is performed by differential activation of spatially distinct electrodes. Different electrodes or other components (i.e. sensors) inserted through a common entry site may also be used to provide different therapeutic benefits (electrical stimulation, magnetic stimulation, drug delivery, etc.) or to gather different types of data (blood glucose level, temperature, pH, etc.).

**[0036]** The stimulation module is designed as either a single implant in a single trajectory or multiple implants with multiple trajectories. Depending on the specific need of the individual, the stimulation module may contain one, a combination, or all of the following components: stimulation electrode(s), recording electrode(s), pulse generator, system control unit, battery, capacitor, current sink, data signal trans-

mitter, data signal receiver, receiver coil, transceiver, transducer, sensors, program storage, memory unit, internal electronics, analysis circuitry or software, etc. All of these components can be contained within a single implant similar to a bion. However, these components can also be broken down into separate units that are implanted in separate trajectories. Because the units pass through a single entry site, they can be hard wired at this point. Optionally, they may communicate wirelessly with each other. For example, if an individual wanted or needed an implant with a longer battery life, then multiple units composed of batteries can be implanted and wired together. Since the battery units do not need to contain an electrode or pass through the inner table of the skull, battery units can be implanted in a trajectory with the maximum length permitted by the curvature of the cancellous portion of the cranium without passing through the inner or outer cortical layers of the cranium. Non-rigid units that curve with the curvature of the cranium permit even longer implants. These curved electrodes can slide into the cancellous skull trapped in between the inner and outer cortical layers. The curved stimulators and electrodes do not have to be stiff or rigid but can be semi-flexible to more easily slide into and maneuver within the cancellous space. In fact only the actual electrode contacts need to pass through the cranium into the epidural or subdural space. All other components can be implanted within the cranium without exiting the cranium. This system is customized with the modules or components specific for each individual, each brain target, and each specific purpose or disorder that is being treated.

**[0037]** The implantable stimulating electrodes and associated components provided herein have a plethora of uses. In addition to existing applications of neuromodulation in Parkinson's Disease and epilepsy, they can be used to stimulate a healthy, normal brain to enhance memory, accelerate learning, etc. (See Singer, Emily, "Want to Enhance Your Brain Power? Research hints that electrically stimulating the brain can speed learning", MIT Technology Review, Jun. 26, 2008; and Giles, Jim, "Electric current boosts brain power" in Nature, Oct. 26, 2004.) They can also be used on a damaged brain to stimulate regeneration, repair as well as to record changes to enable a patient (including non-human patients such as animals) to communicate with the outside world simply by using their brain. This offers hope for patients with paralysis after stroke, spinal cord injury or other disorders (ALS, polio, etc). Another application is to use the implantable cranial electrode as means for brainwave communication between people or other living organisms so that with training, one person (or other living organism, including other animals and potentially plants) can learn to recognize specific patterns of neural signals from another. In this manner it may be possible for people and other living organisms to have invisible, inaudible conversations using only their thoughts and brain waves. This technology has important commercial as well as military applications. Additionally implantable units do not have to access the brain for communication; instead, vibrations generated by implants positioned elsewhere can directly stimulate the inner ear for communication. For example, the stimulator (with multiple components at multiple angles through a single site) may be used as a transmitter and receiver in the inner ear with the capacity to interact with a cell phone (such as via Bluetooth technology) for hands free conversation. Related ear devices have shown success when used in partially deaf people (or other animals)

to transmit auditory signals to the opposite ear as in cases of outer ear or one-sided deafness.

**[0038]** Although electrode stimulation and recording has a wide potential of uses mirroring those currently in use clinically, other preferred embodiments are plentiful. Another preferred embodiment is an implant that uses temperature differences to activate or deactivate the brain or intracranial tissue. In this embodiment, the heat conductive element is implanted through the cranium into the subdural or epidural space. The components that are implanted through other trajectories include those described in the electrode embodiment described above, but also include heat pumps, thermogenerators, and thermoregulators. Cooling the brain typically deactivates the neural activity and can be utilized for seizures, migraines, pain, and other disorders.

**[0039]** The electronic circuitry of the present invention is amenable to various configurations or embodiments. The invention covers the electronic circuitry configurations of any conventional electrodes, stimulators, bions, etc. adapted for insertion of multiple components transversely through the cranium at orthogonal and/or non-orthogonal angles.

**[0040]** Other objectives and advantages of the invention will be set forth in the description which follows. Implicit modifications of the present invention based on the explicit descriptions will be, at least in part, obvious from the description, or may be learned by practice of the invention. Such subtle, predictable modifications and adaptations are taken to be within the scope of the present invention. Additional advantages of the invention may be realized and obtained by means of the instrumentalities and combinations particularly pointed out hereinafter.

#### BRIEF DESCRIPTION OF THE SEVERAL VIEWS OF THE DRAWING

**[0041]** The accompanying drawings, which are incorporated in and constitute a part of the specification, illustrate embodiments of the invention, and together with the general description given above and the detailed description of the embodiments given below, serve to explain the principles of the invention.

**[0042]** FIG. 1 shows how the trajectory of each device or shaft at a particular entry site is defined by an axial angle ( $\theta_1$ ) (Fig. A) and a radial angle ( $\theta_2$ ) (Fig. B). The skull is represented by a hemi-sphere with 2 cross sections in (A) and 1 cross section in (B). FIG. 1A shows two non-orthogonal trajectories both of which have the same axial angle ( $\theta_1$ ) with respect to the perpendicular axis at the entry site. The radial angle ( $\theta_2$ ) is the angle on the tangent plane to the skin or skull at the entry site. For convention anatomic anterior orientation, i.e. the direction towards the front of the face, or the component of the anterior orientation projected onto the tangent plane at the entry site is taken as zero degrees.

**[0043]** FIG. 2 shows multiple devices from different entry sites, but angled such that they converge on the same target within a brain from different directions.

**[0044]** FIG. 3 shows multiple devices inserted from a single entry site at different angles that are divergent from the entry site in order to aim at different targets within a brain.

**[0045]** FIG. 4 demonstrates the geometric relationship between the axial angle of device insertion ( $\theta_1$ ) and device length (l) for straight (non-curved devices) that completely traverse a skull thickness (t) based on a lateral displacement variable (x) when the device is fully inserted,  $\sin \theta = x/l$ .

**[0046]** FIG. 5 illustrates the relationship between the thickness or diameter of the device and the maximal length of the device when the device is implanted at an increasingly greater axial angle ( $\theta_1$ ), i.e. greater non-orthogonal insertional angle. FIG. 5A. shows that a thinner device with smaller diameter can have greater length with greater axial angle of insertion ( $\theta_1$ ). However when the device has a diameter similar to the thickness of the skull, as shown in (B), the length of the device cannot change with any axial angle of insertion ( $\theta_1$ ). FIG. 5B also shows that as the axial angle increases, the tip of the larger diameter device is no longer able to penetrate the inner cortical layer of the skull. Instead the side of the device penetrates the inner cortex. In contrast, (A) demonstrates that a thinner device is still able to penetrate the inner cortex with the tip at greater axial angles ( $\theta_1$ ). Thus in general, non-orthogonal insertion of devices requires that the width or diameter of the device be less than the thickness of the skull.

**[0047]** FIG. 6 illustrates a device comprised of four multiple shafts and components arranged in a linear array on the cortex. FIG. 6A. shows an broad top view while (B) shows a side view, and (C) shows a view from inside the cranium. A single small burr hole is used to insert all four shafts. The single burr hole is of partial thickness because the edges at the bottom of the partial burr hole are used to guide the tips of the self-drilling shafts or drill bits. Two longer shafts flank two shorter shafts resulting in a linear array as seen in (C) where four tips of the shafts are seen protruding through the inner cortex. A linear array of stimulation as shown in FIG. 6 is useful for stimulation along a linear gyms such as for motor cortex stimulation, where typically a small craniotomy is used to place a strip electrode.

**[0048]** FIG. 7 illustrates a device comprised of nine different shafts placed through a single partial small burr-hole. The overall configuration is demonstrated in the cross section of the skull model with three different views in (A), (B), and (C). A top view (D) and bottom view (E) demonstrate the arrangement of the contacts that penetrate through the inner cortex to affect the brain. Four shorter shafts are configured in a “+” configuration while four longer shafts are inserted in an “X” pattern. A central shortest shaft is inserted last. This configuration results in a 3 by 3 matrix of components that can reach the cortex. This type of configuration is useful for epilepsy stimulation where the central electrode senses seizure activity at the seizure focus. This central electrode then activates its own stimulation electrode to abort the seizure. At the same time, the 8 surrounding ring of electrodes are activated as well. The activation of the ring of electrodes help to trap and cancel the spreading wave of seizure activity from the central epileptogenic focus. Such a configuration would generally necessitate a craniotomy; however this configuration is placed through a single partial burr hole.

**[0049]** FIG. 8 illustrates a shaft inserted at an axial angle that serves as a conduit for a guidable and steerable epidural or subdural electrode array. FIG. 8A. shows the drilling of a non-orthogonal hole through the cranium by a self-drilling shaft. In (B), an inner compartment of the shaft is unlocked and removed from the outer threaded portion, leaving a cylindrical conduit. This conduit allows one or more electrode arrays to be inserted into the epidural or subdural space (C). The angled, non-orthogonal trajectory of the shaft allows the electrode array to safely slide into the epidural or subdural space at a shallow angle. In contrast if the burr hole were orthogonally oriented, the electrode array would have to make a 90 degree turn after passing through the skull. The

electrode array can be directed similarly to spinal cord stimulation electrode array using mechanical turning by a small bend in the distal tip of the inner stylet. Alternatively, the distal inner cannular may be ferromagnetic allowing an external magnetic or electromagnetic field to guide or direct the tip of the electrode array. Lastly, a fibroptic inner cannula with distal camera would allow endoscopic guidance of the electrode array under direct visualization of epidural, subdural, or intraventricular structures. The tip of the stylet also would allow for stereotactic image guidance by emitting signals such as radiofrequency or sonic/ultrasonic impulses that help localize the distal tip in stereotactic coordinates. Once the target and desired placement of the electrode array has been accomplished, the proximal end is secured to the cranial conduit/shaft by a locking mechanism. Alternatively, other components such as a battery, controller, transducer, etc. can also be placed inside the cannula, or in other trajectories through the cranium from the same entry site. The combination of multiple shaft placement through a single entry site with multiple steerable electrode arrays allow a limitless configuration of brain stimulation and recording through a single small burr hole.

**[0050]** FIG. 9 demonstrates a simple connection system to physically link multiple shafts and components that are placed through a single or nearby entry sites. The connector shown is a multichannel connector, but any connector would suffice including USB or micro USB connectors. While the components can communicate wirelessly with each other with the appropriate components included within the shaft, some functions are more efficient through direct physical connections.

**[0051]** FIG. 10 demonstrates a preconfigured head unit used to facilitate the placement of multiple shafts and multi-component arrays. FIG. 10A. shows the empty head unit with three docking stations. FIG. 10B shows the insertion of a single shaft into one docking station. Two shafts are inserted into the head unit in (B), while all three shafts have been inserted in (C). The head unit allows direct communication and connection between all shafts and components of the shafts. The head unit itself can also contain multiple components of the overall device such as battery, communication systems, transducers, etc. The head unit can be inserted into a pre made burr hole or be self-inserted by having a self-drilling and self-tapping pointed tip. The head unit does not need to have its own fixation to the skull as the insertion of shafts through the docking stations acts to lock the docking station into the skull. Each docking station can also have adjustable angles of insertion by having a rotating ball and socket mechanism as the docking station through which shafts are inserted.

**[0052]** FIG. 11 shows a flow chart of a method of implanting the devices described herein: (I) identify the target, (II) create an incision, (III) drill a partial thickness burrhole, (IV) identify target and depth from partial thickness burrhole, (V) insert device(s), and (VI) close wound.

#### DETAILED DESCRIPTION OF THE INVENTION

**[0053]** The present invention and method of its use enables multiple effectors, sensors, and other components to fit through a single entry site to provide improved and/or longer-lasting therapeutic benefits. According to some embodiments this is accomplished by inserting the effectors, sensors, other components, or shafts housing any of these elements at different angles to permit greater subsurface reach given a small

surface entry site. As used herein, the term “entry site” includes one or more physically distinct openings, holes, or incisions, within close proximity to one another and taking up a relatively small total area of space consistent with minimally invasive surgical procedures. Thus, an “entry site” may be one opening or hole but is not limited to such. The “entry site” may also be an entry zone, area, or region that encompasses two, three, four, or more distinct openings.

**[0054]** For each entry site, the stimulator/sensor devices may be inserted at several different axial angles between an axis perpendicular to the skin's surface (straight down) and a plane tangent to the skin's surface at the entry site. The effectors (i.e. electrodes) and/or sensors may also be inserted at several different radial angles around the periphery of an entry site in the plane of the tangent to the entry site. The location of the entry site, the axial ( $\theta_1$ ) and the radial ( $\theta_2$ ) insertion angles determine a unique trajectory in the skull and in the body. Preferably, no two stimulator/sensor devices (comprising at least one effector or sensor as part of the device) have the same set of axial ( $\theta_1$ ), radial ( $\theta_2$ ) angles, and entry site location so that each device (and each effector or sensor therein) occupies a unique position different from the others. The closer the first diagonal axial angle is to parallel to the skin surface, the longer the effector or sensor can be while still traversing substantially laterally through the skull without reaching the brain. Conversely, the closer the first diagonal axial angle is to perpendicular to the skin's surface (straight down), the shorter the effector or sensor must be because it is moving more closely to vertical through the skull and is thereby more strictly limited by the skull's vertical thickness. (See FIG. 1.)

**[0055]** Angled implantation allows implantation of extra components to support or work together with the effector or sensor (i.e. electrode) to form a longer-lasting system or improved bion. For example, the main device may be implanted perpendicularly but one or more components (i.e. extended batteries or battery packs) are implanted at an angle. This allows extra components that support a main electrode to be embedded within the skull at an angle. More supporting batteries prolongs the life of the electrode while effectively breaking up the overall implant into several components that are connected (i.e. at the top) by a connector head or connector. Other components, in addition to batteries, can be transmitters, receivers, radio transceivers, heat generators, cooling devices, magnetic coils, capacitors, transformers, ultrasonic transducers, hypersonic emitters/receivers, electrophysiological recording means, sensors, iontophoresis means, optical stimulators, lasers, cameras, address/positioning units, etc.

**[0056]** As used herein, the term “component” includes effectors and sensors but is not limited to these categories. “Component” might also include other categories of auxiliary, complimentary, or supplementary elements that support an effector or sensor but do not themselves produce an effect on a body or sense (gather data) directly. For example, “component” might include a buffer solution, a physical cushion, a catalyst, a battery, a vacuum line, etc. The present invention includes an implant in which at least one component is an effector or sensor. The implant may also include other additional components that are also effectors or sensors, or are neither effectors nor sensors.

**[0057]** The implantable devices described herein are made of biocompatible materials. In a self-inserting embodiment the devices need to be made of material sufficiently durable

and hard to penetrate bone without rupturing. In embodiments that rely on pre-drilling a hole more material options are possible and softer, more flexible materials may be used to encapsulate or house the device. According to a preferred embodiment, at least a portion of the device is made of a semi-permeable material that absorbs some molecules, transmits (flow through) some molecules, elutes some molecules, and blocks some molecules. Such a semi-permeable material may be a mesh with openings (for example, tiny nanopores) therein that optionally also includes key cells or molecules (that provide an auxiliary function) embedded therein on its surface.

**[0058]** According to a preferred embodiment, the effectors are electrodes and supporting components (i.e. transmitters, receivers, etc.) of the present invention are designed to be insertable directly or to insert themselves. By “insert themselves” or “insertable directly” it is meant that the components do not require burr holes to be created in the skull with a drill prior to implant and/or that the components do not require expulsion through an introducer (i.e. needle, cannula, etc.). Self inserted screws of this type are typically classified as self-drilling and self-tapping, in that they do not need a pilot hole nor does the hole need to be tapped to form the threaded tract for a screw. This might be accomplished by the components having distal tips that are sharp or a housing that resembles a screw shaft with threads.

**[0059]** Alternatively, the cranial stimulator devices can be helical in shape such that they wind into the bone in a manner similar to coil anchors for sand volleyball nets. The distal tip of the helix enters into a small hole and the curved tail of the device follows.

**[0060]** When drilling into the skull is necessary such as due to increased resistance from bone making self-tapping screws inadequate, a preferred system and method involves using a balloon along one or more sides of the stimulator device. Drilling often creates a hole that is slightly larger than necessary or imperfect in shape such that there is not a tight fit for the screw. The balloon can be filled with air and/or fluid after insertion in a deflated condition to close the gap, reducing the imperfect mating between drill hole and stimulator to provide an improved friction fit that renders the stimulator less susceptible to internal drift/migration. The balloon can also be used proximally above the stimulator to push the electrode contacts on its opposite distal end into closer contact with the surface of the cortex.

**[0061]** If the effectors contain, are coated with, or are associated with magnetic means (i.e. coils, magnetic materials, etc.) they can be used to provide magnetic stimulation therapy in addition to electrical stimulation therapy. Magnetic energy can also be used to recharge the electrical batteries. For example, inserting a magnetic coil inside the skull enables one to carry out local magnetic stimulation (“intracranial magnetic stimulation”) with a much lower intensity than that used for transcranial magnetic stimulation which requires a large enough magnetic field to travel through the cranium (resulting in a diminution of signal strength in the process) and also is not localized. The inability to localize therapy, also known as poor selectivity, typically results in overbroad application that may cause damage to unintended surrounding regions and too weak an intensity of treatment at the target site. The ability to localize therapy overcomes both of these drawbacks to systemic application.

**[0062]** In addition to electrical and magnetic stimulation the implantable electrode or components associated with it

can be used to generate heat or cold. Heat and cold have been shown to influence brain activity such that they can be used to complement, supplement, or as an alternative to electrical and/or magnetic stimulation.

**[0063]** In addition to electrical and magnetic stimulation the implantable electrode or components associated with it can be used to generate heat or cold. Heat and cold have been shown to influence brain activity such that they can be used to complement, supplement, or as an alternative to electrical and/or magnetic stimulation.

**[0064]** In different embodiments the effector batteries can be recharged inside or outside the body or inside the body through connection to a charging device outside the body. According to a preferred embodiment the effector batteries are recharged inside the body through a naturally occurring means including changes in heat, fluid dynamics, etc. The batteries may include a thermogenerator or thermoelectric generator that uses local heat in situ to generate power. Or, the batteries may include a mechanical power generator that uses natural pulsation of the brain relative to the cranium and changes in cerebrospinal fluid pressure to harness and store energy.

**[0065]** In addition to built-in electrode batteries, the implantable sensor-effector devices of the present invention may be powered by any number of alternative means. In order to reduce their size, they may be powered from outside through a means for receiving energy with the means for receiving energy being smaller than a conventional electrode battery. More specifically, they may rely upon ultrasonic, hypersonic, or radiofrequency energy from a source at another location in the body or outside the body that is absorbed and channeled through a receiving platform. These alternative sources of energy permit the devices to be smaller because a built-in battery is not required. Thus, the device may be made on the scale of microns (length, width, height) rather than millimeters and inserted more deeply into the body, into smaller channels and crevices, or through intact bone and muscle for better accuracy while still being minimally invasive and without sacrificing anatomical structural integrity. Another advantage of the energy source and some of the electronic complexity being outside the body is that it is easier to upgrade and modify from outside. Another advantage of effectors radiating downward and outward from an entry site at different angles is that when a target region for stimulation is deeper within the brain the angle(s) can be set so that rays from more than one effector converge precisely on the deeper target. More than one entry site can be made so that several different devices from several different entry sites converge on the target from different directions (see FIG. 2). Alternatively, when there is more than one target region deep within the brain, effectors from a single entry site can be used to simultaneously reach several different regions by directing the effectors at different angles (see FIG. 3). If the effectors were limited to non-angled, conventional, straight-down insertion all effectors (even through multiple entry sites) would be pointed at the core or center of the brain without the ability to provide targeted therapy to intermediate regions of the brain between the core and the cortex.

**[0066]** In alternative embodiments, the effectors may have additional characteristics that enable them to jointly maximize length and distance within the skull. For example, the effectors may curve with a radius of curvature that approximately matches the radius of curvature or shape of the skull. Since the cranium is composed of three layers, a hard inner

cortical layer, a hard outer cortical layer, and a softer cancellous middle layer, long components can be pushed through the cancellous layer being trapped by the harder inner and outer cortical layers. Additionally, the devices may branch out (for example, telescopically) once inserted to form an intracranial pathway that provides additional battery power storage space. However, because the branches would have to traverse through the somewhat hard bone of the cranium these (bifurcated, trifurcated, poly-furcated) embodiments would probably require separate insertion tools capable of drilling worm-like tunnels for the branched devices.

**[0067]** When the effectors are electrodes the circuitry of the present invention for all embodiments is variable. By electronic circuitry it is meant the arrangement and interrelationship between electrodes, batteries, connectors, coils, transmitters, receivers, transceivers, capacitors, controllers/programming means, address means, pulse control means, sensors, etc. Any configuration of these elements that is functional for multiple electrodes inserted transversely through a single entry site (at orthogonal and/or non-orthogonal angles) is consistent with the scope of the present invention.

**[0068]** In some embodiments, the configuration of electronic circuitry may be similar to that of existing products and patent claims (i.e. the bion of Advanced Bionics, Inc.). However, the entire device is still different from conventional devices and patent claims. It differs by being adapted for insertion transversely through the cranium such as by screw-in and/or insertion at non-orthogonal angles with more than one element inserted through the same entry site.

**[0069]** In other embodiments, the configuration of electronic circuitry is distinctly different in one or more features from conventional products and patent claims, which serves to further distinguish the invention in addition to its other distinguishing features.

**[0070]** As discussed previously, as neurostimulators the devices of the present invention have a myriad of established applications to improve pathologies (movement disorder, psychiatric conditions) and enhance normal functions (learning, memory) in the neural system, particularly through direct interaction with the brain. Additional, potential applications include peripheral nerve stimulation and interaction with other biological systems to catalyze and regulate healing processes. For example, implantable stimulators as described herein may be used at sites of bone fracture or disc degeneration to expedite new bone proliferation as a substitute or supplement to biological or chemical means (bone cement, bone graft, bone filler, bone glue, hydroxyapatite, ground bone composition, or another bone substitute). One specific application is use of stimulators around pedicle screws used in pedicle screw stabilization/fusion of adjacent vertebrae to stimulate bone regrowth over the screws to better camouflage the implants.

**[0071]** According to a preferred embodiment, the devices described herein are used to enable communication between two or more entities with at least one entity being a living organism. The other entities may be other living organisms of the same or a different species as the first living organism, or may be a machine including but not limited to a computer, a laptop, a cell phone, a personal digital assistant (PDA), a keyboard, a camera, a wheel chair, a bicycle, a car, etc. The communication can be one-way, two-way, or a multi-channel exchange amongst several different entities (group conversation, or different entities all communicating with a centralized hub).

**[0072]** In this method of enabling communication between at least one living organism and at least one other entity a device comprising an effector and a sensor is implanted in the living organism. At least one additional component is implanted in the other entities to interact with this device. The sensor in the first entity (living organism) gathers data and generates a pulse that transmits the data to the other entities. The other entities receive the pulse through their components that read and translate it. In this manner the first entity (living organism) can relay information or “talk” to the other entities in open loop communication. In an alternative embodiment, the device in the first entity further comprises at least one feedback component and the communication is closed loop with the feedback component in the first entity verifying receipt of the pulse from the first entity by the second entity.

**[0073]** When receivers or transceivers are used to receive signals they may be used alone to receive signals directly or they may be used in conjunction with one or more intermediary devices that relay and/or process the signal prior to its reception. The intermediary device might amplify or reformat the signal and eliminate noise. In some embodiments, for some applications, the intermediary device could be something similar to a bluetooth earpiece, a cell phone, a wifi router, an air card, etc. Likewise, when effectors are used to induce an effect in an entity (machine or organism) they may induce the effect directly or through one or more intermediary devices that adjust or process the raw information and energy they provide.

**[0074]** The devices described herein are contemplated to be adaptable for use with state-of-the-art sixth sense and mind control devices. The minimally invasive implants of the present invention may be more convenient than headgear and may be used to read neural states and objectives to initiate actions in the outside world rather than relying on hand gestures from the living organism subject or patient. As used herein (before and after), the term “patient” refers to any object that subjects itself or is subjected to a treatment incorporating the present invention. A “patient” need not be an ill person or someone with physical, emotional, or psychological impairments or abnormalities. In fact, a “patient” need not be a human being or even a living organism. A “patient” may include completely healthy, happy, and successful organisms or objects that choose to subject themselves to treatment or are subjected to treatment with the present invention in order to further their abilities and become even more successful or to improve certain functions.

**[0075]** Examples of conditions the devices of the present invention can be used to treat include: psychological conditions generally, genetically or biologically based psychological conditions, depression, acute mania, bipolar disorders, hallucinations, obsessions, obsessive compulsive disorder, schizophrenia, catatonia, post-traumatic stress disorder, drug and alcohol addiction, Parkinson’s disease, Alzheimer’s disease, epilepsy, dystonia, tics, stuttering, tinnitus, spasticity, recovery of cognitive and motor function following stroke, pain syndromes, migraine, neuropathies, back pain, internal visceral diseases, urinary incontinence, etc.

**[0076]** Specific medical applications include using the cranial implants of the present invention as follows: (i) enabling a paralyzed man to send signals to operate a computer by “telepathically” moving a mouse, cursor, or typing on a keyboard, improving one’s ability to work; and (ii) enabling a paralyzed man to send a signal causing a machine or com-

puter to speak a phrase or message for them so that they can communicate their needs, desires, and thoughts to others and the world.

**[0077]** Specific entertainment and social applications include using the cranial implants of the present invention as follows: (i) a person has a Cranion™ implanted so that he can use it to control his iPhone or Wii game console without using his hands or in addition to hand controls; and (ii) a person has a Cranion™ implanted to communicate with one or more other persons, each with his own Cranion™ implanted to enable private “telepathic” conversations in a group of people including at a meeting, in church, in the courtroom, at a sporting event, and during a card game.

**[0078]** Implanted devices of the present invention (especially those in the brain) may be used to control a projector, a camera, a laser, a bar code reader, etc. worn on the body. Such sixth sense and mind control devices may find application for video games, electronic transfers of money, trading stocks, shopping, social and professional networking and storage of data about people, filming, photography, etc. The implants could be used to read expressive conditions (facial expressions, gestures) and emotional experiences (affective response) of the living organism in which they are implanted or of others with whom the patient comes in contact. The implants could then process and analyze this information to initiate cognitive actions in response thereto.

**[0079]** It is known that an electrical signal at the cortex of the brain looks random across the population for the same thought, even though it originates from the same region of the brain, due to a unique fold pattern of each person’s brain similar to fingerprints. Headgear uses a mathematical algorithm to unlock the random signal to make it consistent across the population. Alternatively, the implants of the present invention might be used (i) to read the signal from a source in the brain beyond the cortex where it is uniform without the algorithm, (ii) apply the algorithm to data read at the cortex, or (iii) to provide an initial equilibration process that compensates for the differences in signals from one person to another.

**[0080]** According to still other embodiments, the Cranion™ has a longer electrode lead that passes through the skull at an angle and goes epidural to distant areas like a spinal cord stimulator sliding up the epidural space in the spine. This tip may then be steerable, for example, with a magnet.

**[0081]** The general method, as summarily illustrated in the flow chart of FIG. 12, in greater detail may encompass the following sequence:

- [0082]** 1.) Use stereotactic localization, either with a frame or frameless stereotactic localization to identify a target(s);
- [0083]** 2.) Decide on a configuration. For example, either single electrode, multiple around the single target, single line (see FIGS. 7 and 8);
- [0084]** 3.) Single stab incision 5-10 mm;
- [0085]** 4.) Drill 2-4 mm partial thickness burrhole (this allows an “edge” so that drills can be angled into the corner and an off angle trajectory can be accomplished);
- [0086]** 5.) Use stereotactic localization to identify target and depth away from the central partial burrhole;
- [0087]** 6.) Plan trajectory based on the target and either drill a pilot hole or use a self drilling, self tapping Cranion™ to insert the Cranion™ device;
- [0088]** 6a.) Drilling a pilot hole allows exact knowledge of the depth of the hole however a cannulated

Cranion™ in which the sharp tip can be removed (see FIG. 9) also allows a portal to determine whether the epidural space has been entered.

**[0089]** 7.) Place other Cranions™ and connect them with wires (see FIG. 9) or have them connect wirelessly. Or, use the head device.

**[0090]** 8.) Add other components such as extra batteries that don't need to go all the way out of the skull.

**[0091]** 9.) Close the wound

**[0092]** The present invention is not limited to the embodiments described above. Various changes and modifications can, of course, be made, without departing from the scope and spirit of the present invention. Additional advantages and modifications will readily occur to those skilled in the art. Therefore, the invention in its broader aspects is not limited to the specific details and representative embodiments shown and described herein. Accordingly, various modifications may be made without departing from the spirit or scope of the general inventive concept as defined by the appended claims and their equivalents. As used in the claims the conjunction "or" means the inclusive or (and/or, either element independently or any combination of the elements together).

1: A device configured to create an effect on or gather data about a target site in a living body, comprising:

one or more shafts configured to be inserted through skin, muscle, tissue, bone, or skull at an entry site; and at least one component, including an effector or a sensor, associated with each of said one or more shafts, each of said at least one component coupled to its associated shaft by one or more of: being housed within, passing through, or being attached to each of said one or more shafts;

wherein each of said one or more shafts and its associated component are configured to be inserted at an angle, between and inclusive of parallel to a tangent of a surface at the entry site and perpendicular to a tangent of a surface at the entry site;

wherein each of said one or more shafts is configured to be inserted at the entry site at different trajectories from all other shafts; and

wherein a length of each shaft and its associated component is independent of other shafts and their associated components and is not limited to the thickness of the skin, muscle, tissue, bone, or skull at the entry site.

2: The device of claim 1, wherein the components, including the effector or the sensor, are selected from the group consisting of: a battery, an electrode, a recharger, a transmitter, a receiver, a transceiver, a sensor, a recorder, a capacitor, a transformer, a system control unit, a programmer, an address/positioning unit, a temperature sensor, a temperature adjuster, a thermogenerator, a thermoelectric generator, a mechanical power generator, a photo/light generator, an ultraviolet light generator, an infrared generator, an optical stimulator, a laser, a radiofrequency generator, a magnetic field generator, a mechanical vibration generator, an ultrasonic wave generator, an electrical field generator, a radiation generator, a fuel cell, a drug delivery unit, a gene therapy delivery unit, a reservoir for drugs and radioactive substances, and a reservoir for substances released into a body.

3: The device of claim 1, wherein each shaft is configured to be inserted through skin, tissue, or bone when a pre-made hole is not present, the shaft being self-drilling and/or self-tapping.

4: The device of claim 1, wherein the target site is in a patient's brain, and the effector or the sensor communicates with the target site such that effects of the effector extend to the patient's brain, or stimuli that activate the sensor are derived from the patient's brain.

5: The device of claim 1, wherein the bone is a skull and a combined length, minus any overlap, of the shaft and its components, including effectors and/or sensors, results in a part of the device or its components, including effectors or sensors, being placed: (i) superficial to the skull within skin, fat tissue, connective tissue, ligament, tendon, mucosa, or muscle, (ii) within bone or skull (iii) epidurally (upon dura mater), (iv) subdurally (below dura mater), (v) epidurally (upon pia mater), (vi) within a brain tissue, or (vii) within a ventricle or cistern associated with the brain.

6: The device of claim 5, wherein the components, including effectors and/or sensors, are located on or are composed of a rigid, semi-rigid, or flexible housing that travels through the shaft;

wherein the housing is a metal, a plastic, a polymer, a mesh, a fabric, or a woven material, and

wherein the shaft and/or one or more components, on or within the flexible housing traveling through the shaft, is guided to the target location by one of the following or a combination of the following mechanisms:

i) mechanical steering of the housing such as an inner stylet that is steerable by having a bendable tip or that has a bend in a tip that is steerable by rotating, advancing, or withdrawing the housing and stylet;

ii) magnetic steering of the housing wherein a ferromagnetic, or electromagnetic tip of the housing or the tip of a removable stylet within the housing is guided, steered, or moved by a magnetic field induced by a magnetic or electromagnetic mechanism either inside or outside the body;

iii) stereotactic guidance to the target where stereotactic localization is based on one or a combination of the following techniques: Magnetic Resonance Imaging (MRI), functional Magnetic Resonance Imaging (fMRI), Magnetic Resonance Spectroscopy (MRS), diffusion MRI (DWI), diffusion tensor MRI (DTI), electroencephalography (EEG), magnetoencephalography (MEG), nuclear neuroimaging, positron emission tomography (PET), single photon emission computed tomography (SPECT), Ictal-Interictal SPECT Analysis by Statistical Parametric Mapping (ISAS), Computed Tomography (CT), x-ray, fluoroscopy, angiography, ultrasonography, transcranial magnetic stimulation (TMS), transcranial direct current stimulation (tDCS), transcranial electrical stimulation (TES), motor evoked potential (MEP), somatosensory evoked potential (SSEP), phase reversal of somatosensory evoked potential, evoked potential, electrocorticography (ECoG), direct cortical electrical stimulation (DCES), microelectrode recording (MER), and local field potential recording (LFP);

iv) endoscopic visualization and guidance.

7: The device of claim 1, further comprising a head unit attached to or associated with an end of the first shaft,

wherein the head unit comprises one or more docking stations, each configured to receive at least one additional component or shaft housing the component;

wherein the docking station has one or more holes or couplings therein, through which one or more component(s)

- or shaft(s) housing these components is (are) inserted through, attached to, coupled with, or connected with the head unit;
- wherein the docking stations are radially spaced around the head unit, in order that several components or shafts housing these components may be inserted at a single common entry site through the same head unit and directed perpendicularly downward, radially outward, or radially inward at different angles around the head unit.
- 8:** The device of claim 7, wherein the head unit is a connector between multiple implanted components, shafts housing these components, or devices, and
- wherein the head unit allows direct electrical contact between one or more additional component(s), or shaft (s) housing these components, and the first shaft of the device inserted through a common entry site, thereby allowing direct communication, connection, or power transfer between the additional component(s) or shaft(s) and the first shaft.
- 9:** The device of claim 1, wherein said effect comprises one or more of the following:
- electrical stimulation or electrical disruption of the target site;
  - mechanical stimulation or mechanical disruption of the target site;
  - changing temperature at the target site;
  - inducing a magnetic field at the target site;
  - photostimulation or photoinhibition of the target site, including photomodulation and use of laser to stimulate or inhibit a process at the target site;
  - ultrasonic stimulation or ultrasonic disruption of the target site;
  - inducing a vibration that is transmitted to the target site, including a sonic vibration that is transmitted to and activates auditory receptors;
  - creating and modulating an electrical field for iontophoresis or iontophoresis at the target site;
  - and irradiating the target site.
- 10:** The device of claim 1, wherein said gathers data comprises one or more of the following:
- monitoring signals of single neurons and of populations of neurons;
  - monitoring intracranial pressure;
  - monitoring physiologic signals;
  - monitoring metabolic activity and other signals of tissues including neurons, glial cells, blood cells, immune cells, and other cells;
  - monitoring signals derived from cellular and sub-cellular components including proteins, DNA, RNA, molecules, neurotransmitters, hormones, and mitochondria;
  - measurement of components, states of components, or physical properties in a body including electrolytes, proteins, hormones, amino acids, molecules, carbohydrates, minerals, fatty acids, osmolarity, osmolality, pharmaceuticals, radioactive tracers, light, electromagnetic energy, fluorescence, radiation, and other measurable items;
  - monitoring optical, fluorescent, ultraviolet, infrared, and/or birefringence signals, and/or changes therein, emitted from tissues including neurons, glial cells, blood cells, other cells, blood and cerebral spinal fluid; and/or
  - monitoring temperature of tissue and changes thereof.
- 11:** The device of claim 1, wherein each said shaft has physical properties similar to or different from other shafts, including the following properties:
- is straight;
  - is curved;
  - is curved to follow a contour curvature of bone or skull;
  - is curved in a spiral that skewers into the body or skull through the entry site;
  - can change shape during an insertion process as it is inserted;
  - is rigid;
  - is at least partially flexible;
  - changes between rigid and flexible states;
  - has a sharp tip;
  - has a blunt tip;
  - has a tip that is not sharp enough to puncture cortical bone;
  - has an atraumatic curved tip that can be easily inserted into a premade entry site;
  - is threaded and configured to be screwed into position;
  - is made of a selectively permeable material that differentially absorbs, transmits, repels, and elutes different molecules;
  - is made of a selectively permeable material that comprises cells embedded therein; and/or
  - is made of a selectively permeable material that is a nanoporous mesh.
- 12:** The device of claim 1, having at least one effector, wherein the effector is encased within a protective housing and capable of stimulating tissue by transmitting energy through the housing.
- 13:** The device of claim 1, having at least one effector or sensor, wherein the effector or sensor protrudes out of an end of a shaft or is located on a surface of a shaft.
- 14:** A device that creates an effect on a target site or that gathers data about a target site in a patient's body, comprising:
- a first shaft configured to be inserted through skin, muscle, tissue, bone, or skull; and
  - at least one component, including an effector and/or sensor, housed within, passing through, or attached to the first shaft;
- wherein the shaft is configured to be self-inserting through an entry site in an absence of a premade hole, said first shaft having a diameter of less than 1 cm.
- 15:** The device of claim 14, wherein the first shaft is configured to be self-inserting, at the entry site, orthogonally to a tangent of a surface at the entry site.
- 16:** The device of claim 14, wherein the first shaft is configured to be self-inserting, at the entry site, at an angle between parallel and perpendicular to a tangent of a surface at the entry site.
- 17:** A system of devices according to claim 14, wherein two or more devices are configured to be inserted through the entry site, such that the entry site is common to two or more devices.
- 18:** The system of claim 17, wherein at least one device is configured to be inserted orthogonally to a tangent of a surface at the entry site.
- 19:** The system of claim 17, wherein each device comprises a single shaft and all components of that device are housed within that shaft.
- 20:** A method of creating an effect on a target site using the device of claim 14, wherein the device has at least one effector, comprising:

inserting the device at an oblique angle at the entry site; and activating the effector.

**21:** A method of gathering data about a target site using the device of claim **14**, wherein the device has at least one sensor, comprising:

inserting the device at an oblique angle at the entry site; and receiving data through the sensor.

**22:** A method of providing electrical stimulation therapy to a patient's brain using the device of claim **1**, having at least one electrode, comprising:

implanting the device in the skull and generating a pulse from the electrode;

wherein an insertion angle of the device is related to device length such that when the device is fully inserted the length traverses entirely through the skull, at the insertion angle, and terminates such that at least one electrode is epidural, subdural, or epipial and contacts dura, arachnoid, pia, or a cortex of the brain.

**23:** A method of providing electrical stimulation therapy to the body using the device of claim **1**, having at least one electrode, comprising:

implanting the device in the body and generating a pulse from the electrode(s);

wherein the insertion angle ( $\theta$ ) is related to device length ( $l$ ) such that:

$$\sin \theta = x/l$$

wherein  $\theta$  is measured from an axial line perpendicular to a skin's surface at the entry site; and

$x$  is lateral displacement in a direction parallel to the skin's surface at the entry site when the device is fully inserted.

**24:** A method of implanting the device of claim **1**, having one or more additional shaft(s) housing additional components, comprising:

(i) inserting a head unit, with or without a shaft, perpendicularly to a skin's surface;

(ii) inserting another shaft housing additional components through the head unit at any first angle between parallel and perpendicular to the skin's surface and at any second radial angle around the head unit;

(iii) inserting one or more additional shafts, each shaft housing additional components, through the head unit, at any first angle between parallel and perpendicular to the skin's surface and at any second radial angle around the head unit, wherein either the first angles or the second angles or both for any two shafts are different, such that each shaft occupies a unique position with respect to the other shafts.

**25:** A method of providing electrical stimulation therapy to a living body using the device of claim **1**, having at least one electrode, comprising:

implanting the device in the body; and

generating one or more pulses from the electrode(s);

in order to provide therapy to a patient for treatment of a condition selected from the group consisting of: epilepsy, stroke, movement disorders, Parkinson's Disease, tremor, multiple sclerosis, dystonia, tics, Tourette's Syndrome, stuttering, depression, pain, headache, migraine headache, trigeminal neuralgia, facial pain, insomnia, narcolepsy, attention deficit disorder (ADD), attention deficit hyperactivity disorder (ADHD), autism, obesity, paralysis, blindness, deafness, benign tumors of brain and body, malignant tumors of brain and body, neurodegenerative disorders, alopecia, dementia, altered con-

sciousness states, psychiatric disorders (including obsessive compulsive disease, bipolar depression, anxiety, schizophrenia, neuroses, and psychoses), criminal behavior, sexual dysfunction, erectile dysfunction, and addictions related to brain activity including addictions to the following: drugs (including narcotics, pain medications, sedatives, stimulants), illicit drugs (including cocaine, marijuana, heroin, methamphetamine), prescription drugs, muscle relaxants, tobacco (smoking), alcohol, food, sex, pornography, pedophilia, gambling, thrill seeking, television, video games, and the internet.

**26:** A method of providing electrical stimulation therapy to a patient's brain using the device of claim **1**, having at least one electrode, comprising:

implanting the device in a skull and generating one or more pulses from the electrode;

wherein stimulation resulting from the pulse(s), increases or accelerates at least one benefit selected from the group consisting of: learning, attention, mental focus, memory, cognitive abilities, intelligence, mental performance, intelligence quotient (IQ), positive attitude, ambition, self determination, self confidence, creativity, social skills, interpersonal skills, and emotional intelligence (EQ).

**27:** A method of enabling communication between two or more entities, at least one entity being a living organism, comprising:

implanting the device of claim **1**, in a first entity, said first entity being part of a living organism.

**28:** The method of claim **27**, wherein the communication includes the following forms:

electromagnetic, acoustic, ultrasonic, and forms comprising frequencies outside a range of human hearing.

**29:** The method of claim **27**, the device further comprising at least one component, such as a receiver or transceiver, and further comprising:

the receiver or transceiver receiving input from at least one other entity;

wherein said receiving input includes, but is not limited to, indirectly receiving input through one or more intermediary devices that relays, modulates, and/or processes one or more signals between the entities.

**30:** The method of claim **29**, wherein the other entity is a radio, radio transmitter, musical player, cell phone, personal digital assistant, computer, or internet.

**31:** The method of claim **27**, the device further comprising at least one component adapted to transmit, communicate, or broadcast, such as a transmitter or transceiver, and further comprising:

the transmitter or transceiver transmitting, communicating, or broadcasting information to at least one other entity;

wherein said transmitting, communicating, or broadcasting includes, but is not limited to, transmitting, communicating, or broadcasting through one or more intermediary devices that relays, modulates, and/or processes one or more signals between the entities.

**32:** The method of claim **27**, the device further comprising at least one component adapted to receive, such as a receiver or transceiver, and/or at least one component adapted to transmit, such as a transmitter or transceiver, and further comprising:

implanting at least one additional component or identifying a receiver capability in a second entity;

- gathering data/signals in the first entity with a sensor of the device;  
 transmitting these data/signals to the second entity; and  
 receiving these data/signals from the first entity in the second entity through the additional component or through an already present receiver capability in the second entity.
- 33:** The method of claim **32**, further comprising:  
 a second entity communicating or responding to the first entity by transmitting data/signals to the first entity, resulting in the effector of a device in the first entity generating a signal in the first entity,  
 including when the device in the first entity that receives the data/signals from the second entity is a different device in a different location than the device in the first entity that transmits data/signals to the second entity,  
 wherein this form of communication between two or more entities is two-way, recurrent, reciprocal, or closed-loop communication.
- 34:** The method of claim **33**, the device in the first entity further comprising at least one feedback component, and further comprising:  
 upon the first entity transmitting data/signals to the second entity;  
 the second entity verifying receipt of the data/signals transmission by sending a response, feedback, or verification signal to the first entity and  
 thereby facilitating closed loop communication between two or more entities.
- 35:** The method of claim **34**, wherein the verification step, involving the second entity sending a feedback signal to the first entity, is contingent on an effect in the second entity, such as generation or induction of a specific signal/response or completion of a desired task.
- 36:** The method of claim **27**, further comprising:  
 gathering data by a sensor on the device in the first entity; and  
 communicating the data to one or more second entities;  
 wherein the data relates to neuronal activity or physiological parameters.
- 37:** The method of claim **32**, further comprising:  
 initiating the transmission, from the first entity to the second entity, through a signal in the first entity;
- wherein the signal is induced by: activation of an effector of a device, electrode stimulation, vibrations, alterations in temperature/pressure/light, patterns of neural activity, and/or changes in cellular activity.
- 38:** The method of claim **32**, further comprising:  
 at least one component in the second entity recognizing specific signals as being from certain other entities.
- 39:** The method of claim **32**, further comprising:  
 at least one component in the second entity interpreting specific signals as indicating certain conditions.
- 40:** The method of claim **32**, wherein the second entity is a different part of the same living organism of which the first entity is a part.
- 41:** The method of claim **27**, wherein a second entity involved in the communication is also a living organism.
- 42:** The method of claim **41**, wherein the first entity and the second entity are living organisms having brains and the communication is brainwave communication.
- 43:** The method of claim **27**, wherein a second entity involved in the communication is a machine.
- 44:** The method of claim **43**, wherein the machine is selected from the group consisting of one or more of the following: a computer, a cell phone, a phone, a personal digital assistant, a muscle stimulator, a wheelchair, a motorized vehicle, a robot, and an electronic circuit.
- 45:** A method of providing electrical stimulation therapy using at least two of the devices of claim **1**, each device having at least one electrode as the effector, comprising:  
 implanting a first device through the skull at a first entry site;  
 implanting a second device through the skull at a second entry site;  
 generating a pulse from at least one electrode on the first device; and  
 generating a pulse from at least one electrode on the second device;  
 wherein the target site is in a brain of a patient between a center of the brain and the skull, and an orientation of at least one electrode on the first device and at least one electrode on the second device are selected so that at least one electrode from each device is directed at the target site.

\* \* \* \* \*

专利名称(译)	通过颅内非正交和正交轨迹插入医疗器械和使用方法		
公开(公告)号	<a href="#">US20120046531A1</a>	公开(公告)日	2012-02-23
申请号	US13/318462	申请日	2010-12-21
[标]申请(专利权)人(译)	华宣威		
申请(专利权)人(译)	华宣威		
当前申请(专利权)人(译)	华宣威		
[标]发明人	HUA SHERWIN		
发明人	HUA, SHERWIN		
IPC分类号	A61B5/01 A61N1/05 A61B6/00 A61B8/00 A61M5/168 A61F7/00 A61N5/06 A61N5/067 A61N1/36 A61B19/00 A61B5/055 A61B6/03 A61N2/00 A61N7/00 A61B5/145 A61B5/1459 A61B5/03 A61B5/00		
CPC分类号	A61B5/6865 A61N1/0531 A61N1/0539 A61B5/0478 A61N1/36064 A61N1/36139 A61B5/6868 A61B5/4836 A61B5/4094 A61B5/0482 A61B5/6882 A61B5/4064 A61B5/4076 A61B17/1695		
优先权	61/288619 2009-12-21 US		
其他公开文献	US9179875		
外部链接	<a href="#">Espacenet</a> <a href="#">USPTO</a>		

摘要(译)

本发明包括一个细长装置，适于插入，包括自我插入穿过身体，尤其是头骨。该装置具有至少一个效应器或传感器，并且被配置为通过以不同角度引导部件，允许多个功能部件通过单个进入部位植入到颅骨中。该装置可用于向患者的大脑提供电，磁和其他刺激疗法。效应器，传感器和其他组件的长度可以完全穿过颅骨厚度（以对角线角度），几乎不会突出到大脑的皮质。这些成分可能直接接触大脑的皮质，但从那里它们的信号可以被引导到大脑深处的目标。效应器长度与其电池尺寸和存储电荷的能力成正比。因此，不受颅骨厚度限制的较长角度的电极效应器允许更持久的电池，这扩展了治疗选择。

