



US 20070078318A1

(19) **United States**

(12) **Patent Application Publication** (10) **Pub. No.: US 2007/0078318 A1**

Kling et al.

(43) **Pub. Date: Apr. 5, 2007**

(54) **MUCOSAL SENSOR FOR THE ASSESSMENT OF TISSUE AND BLOOD CONSTITUENTS AND TECHNIQUE FOR USING THE SAME**

Publication Classification

(51) **Int. Cl.**
A61B 5/00 (2006.01)
(52) **U.S. Cl.** **600/323**

(76) **Inventors: Carl Kling, San Ramon, CA (US); Shannon Campbell, Oakland, CA (US)**

Correspondence Address:
**FLETCHER YODER (TYCO INTERNATIONAL, LTD.)
P.O. BOX 692289
HOUSTON, TX 77269-2289 (US)**

(57) **ABSTRACT**

A sensor for physiological constituent detection may be adapted to include a mucoadhesive. A sensor is provided that is appropriate for use on mucosal tissue. The mucoadhesive provides a mechanism for holding the sensor on the mucous membrane in order to measure physiological constituent levels in the tissue and blood.

(21) **Appl. No.: 11/241,724**

(22) **Filed: Sep. 30, 2005**

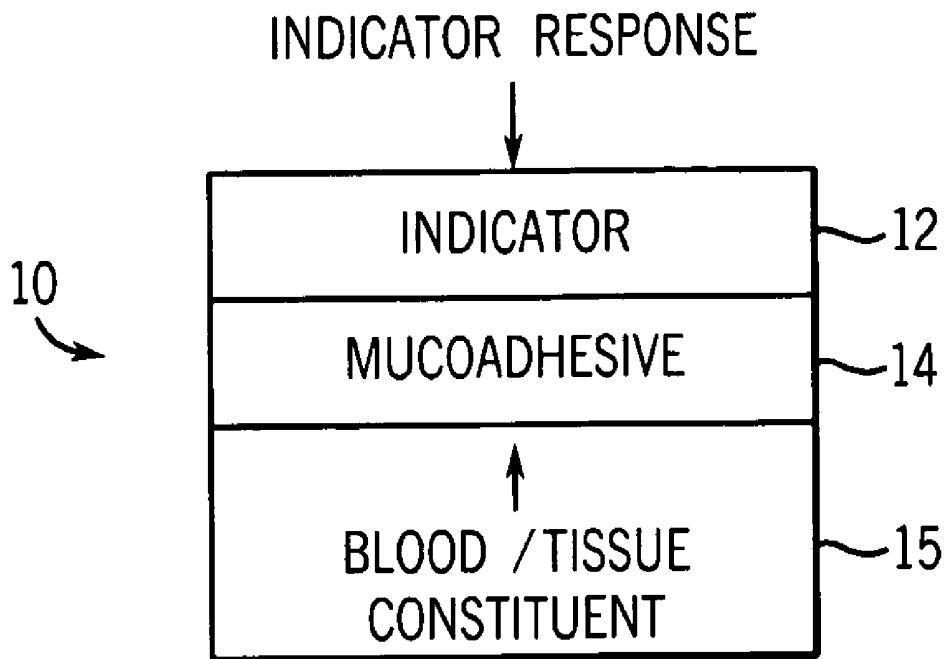

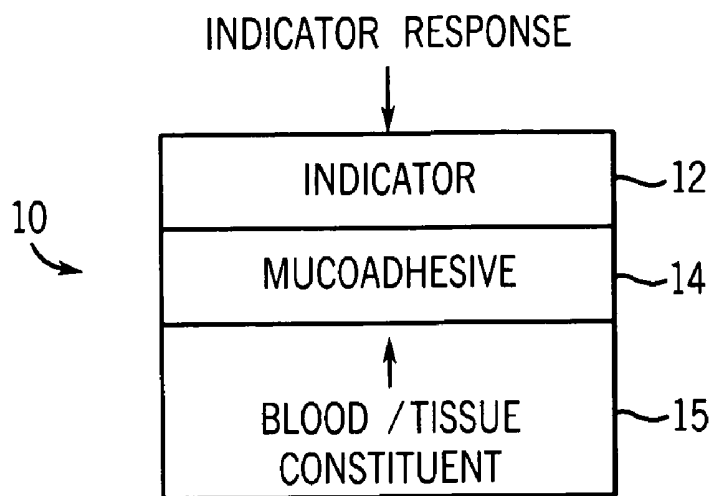

FIG. 1

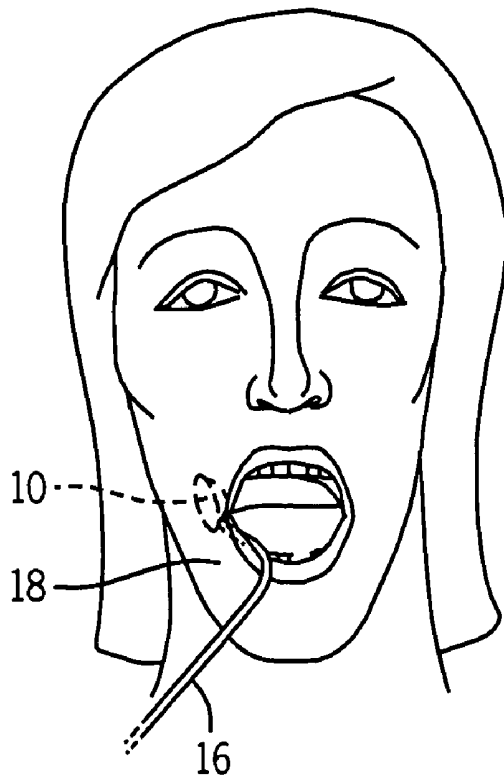
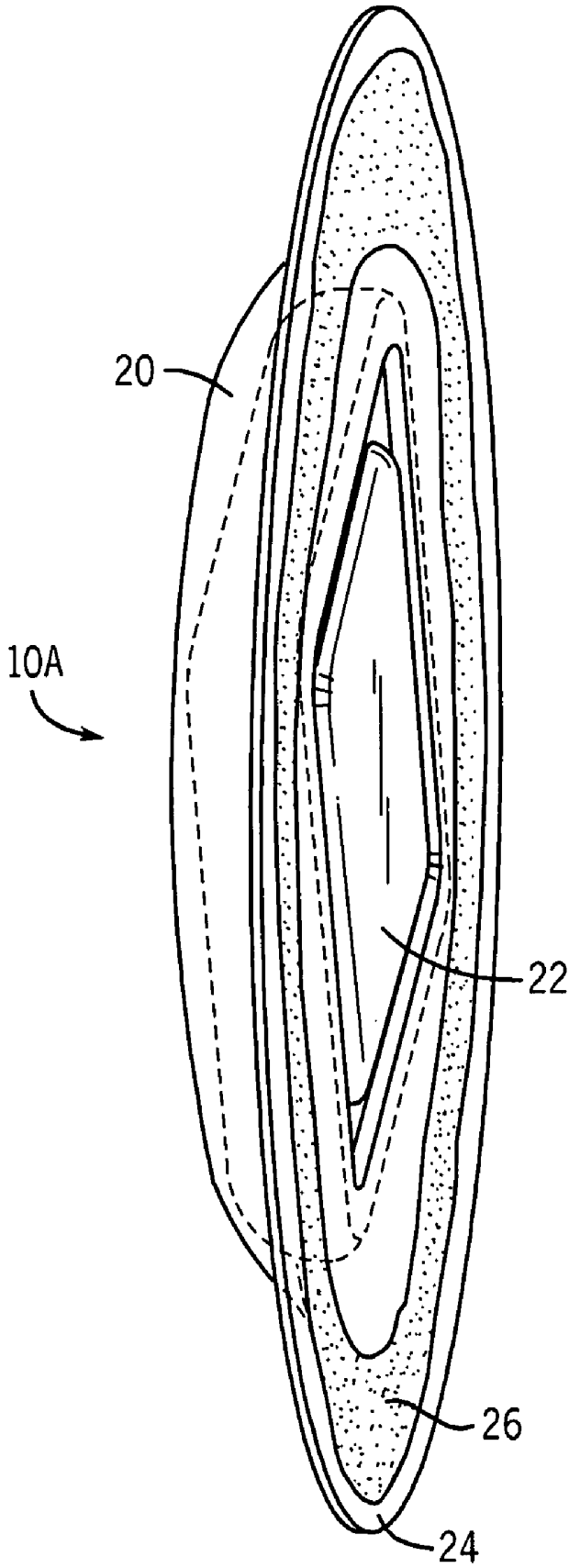

FIG. 2



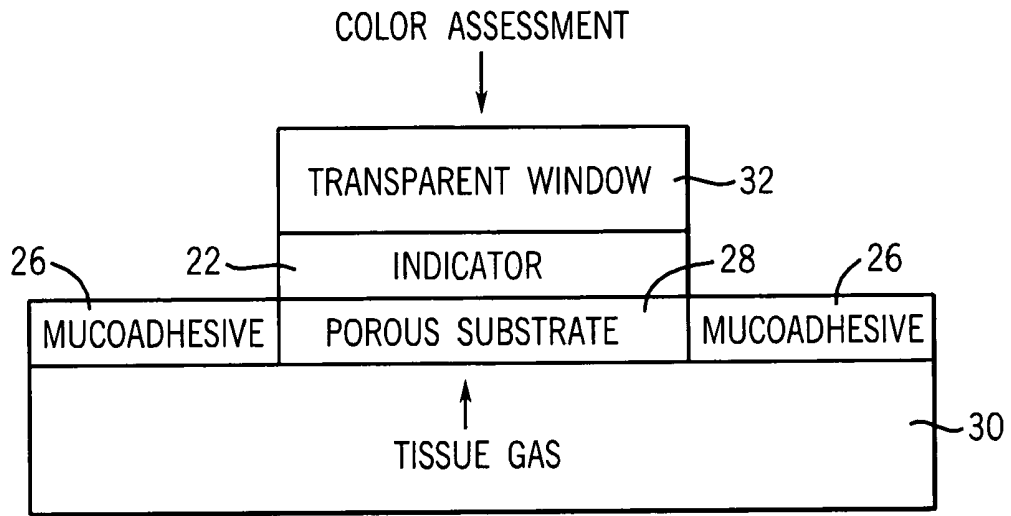

FIG. 4

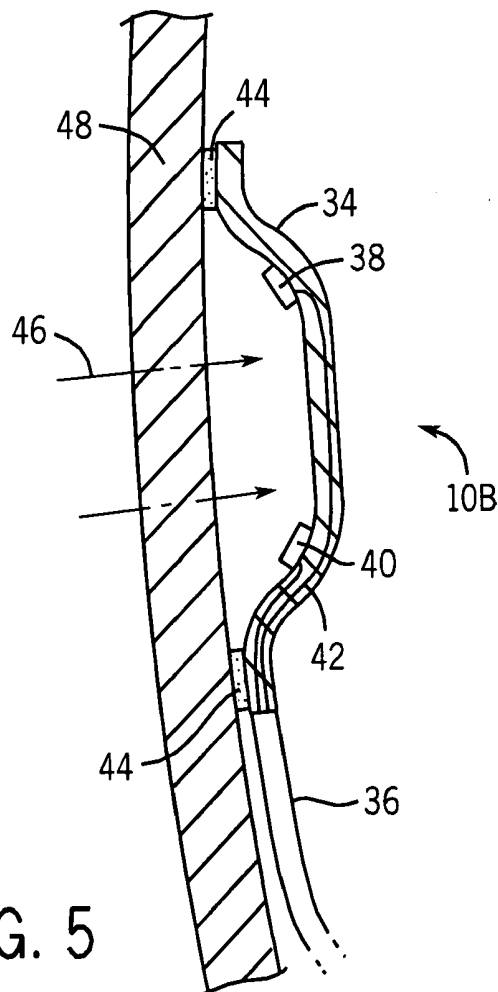

FIG. 5

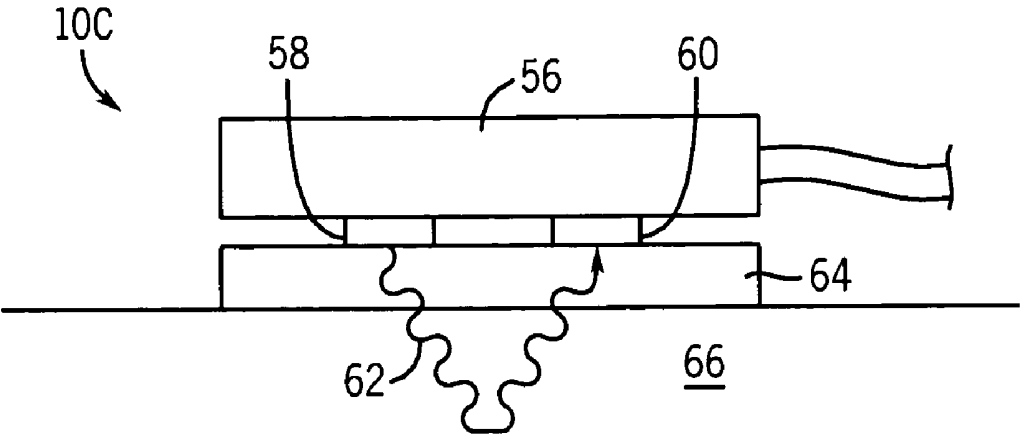

FIG. 6

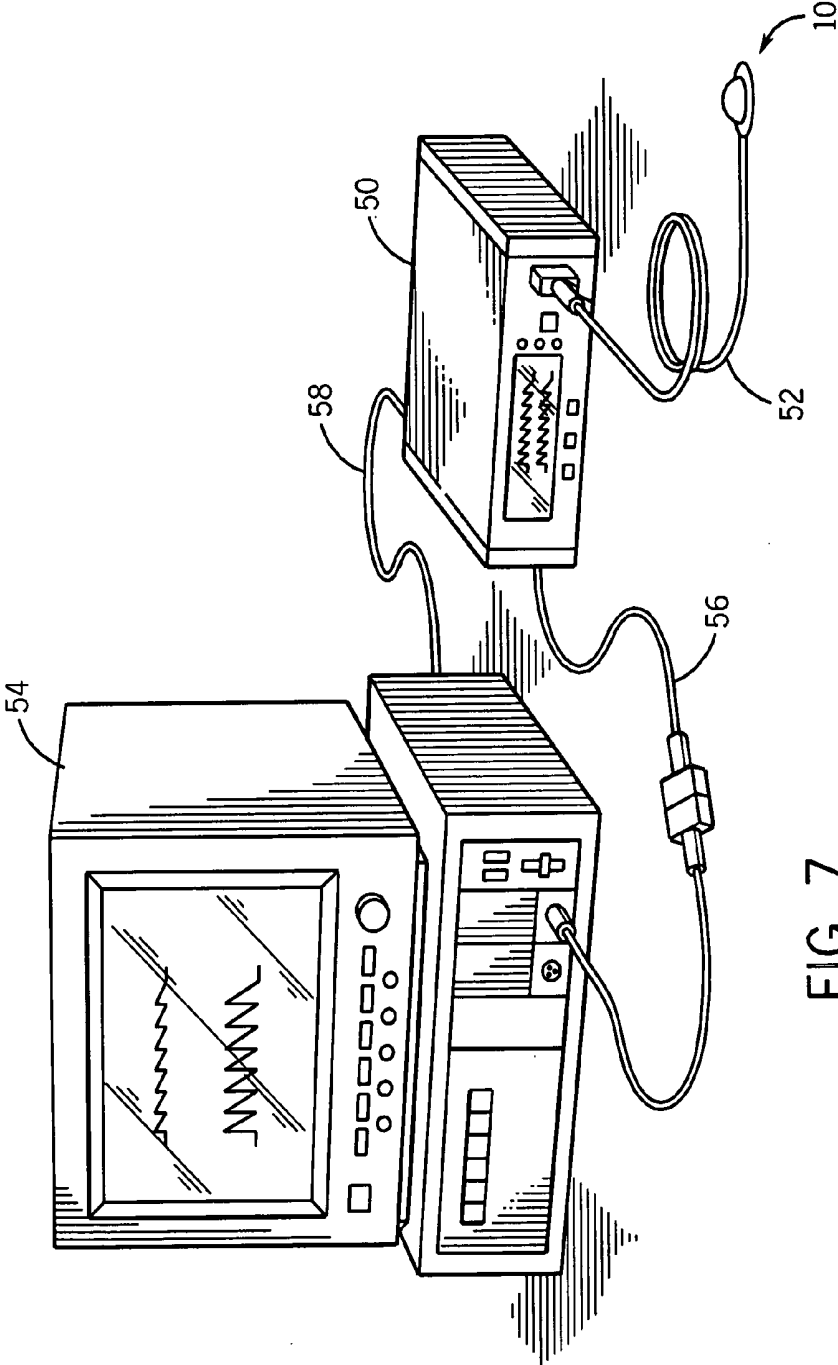

FIG. 7

**MUCOSAL SENSOR FOR THE ASSESSMENT OF
TISSUE AND BLOOD CONSTITUENTS AND
TECHNIQUE FOR USING THE SAME**

BACKGROUND OF THE INVENTION

[0001] 1. Field of the Invention

[0002] The present invention relates generally to medical devices and, more particularly, to sensors placed on a mucosal surface used for sensing physiological parameters of a patient.

[0003] 2. Description of the Related Art

[0004] This section is intended to introduce the reader to various aspects of art that may be related to various aspects of the present invention, which are described and/or claimed below. This discussion is believed to be helpful in providing the reader with background information to facilitate a better understanding of the various aspects of the present invention. Accordingly, it should be understood that these statements are to be read in this light, and not as admissions of prior art.

[0005] In the field of medicine, doctors often desire to monitor certain physiological characteristics of their patients. Accordingly, a wide variety of devices have been developed for monitoring many such characteristics of a patient. Such devices provide doctors and other healthcare personnel with the information they need to provide the best possible healthcare for their patients. As a result, such monitoring devices have become an indispensable part of modern medicine.

[0006] One technique for monitoring certain physiological characteristics of a patient is commonly referred to as pulse oximetry, and the devices built based upon pulse oximetry techniques are commonly referred to as pulse oximeters. Pulse oximetry may be used to measure various blood flow characteristics, for example the blood-oxygen saturation of hemoglobin in arterial blood, the volume of individual blood pulsations supplying the tissue, and/or the rate of blood pulsations corresponding to each heartbeat of a patient. In fact, the "pulse" in pulse oximetry refers to the time varying amount of arterial blood in the tissue during different phases of the cardiac cycle.

[0007] Pulse oximeters typically utilize a non-invasive sensor that transmits electromagnetic radiation, for example light, through a patient's tissue and that photoelectrically detects the absorption and scattering of the transmitted light in such tissue. One or more of the above physiological characteristics may then be calculated based upon the amount of light absorbed and scattered. More specifically, the light passed through the tissue is typically selected to be of one or more wavelengths that may be absorbed and scattered by the blood in an amount correlative to the amount of the blood constituent present in the tissue. The measured amount of light absorbed and scattered may then be used to estimate the amount of blood constituent in the tissue using various algorithms.

[0008] Pulse oximetry is sensitive to movement, and various types of motion may cause artifacts that may obscure the blood constituent signal. For example, motion artifacts may be caused by moving a sensor in relation to the tissue, by increasing or decreasing the physical distance between emit-

ters and detectors in a sensor, by changing the direction of emitters or detectors with respect to tissue or each other, by changing the angles of incidence and interfaces probed by the light, by directing the optical path through different amounts or types of tissue, or by expanding, compressing or otherwise altering tissue near a sensor. In the emergency room, critical care, intensive care, and trauma center settings, where pulse oximetry is commonly used for patient monitoring, the wide variety of sources of motion artifacts includes moving of a patient or the sensor by healthcare workers, physical motion of an unanaesthetised or ambulatory patient, shivering, seizures, agitation, response to pain and loss of neural control. These motions oftentimes have similar frequency content to the pulse, and may lead to similar or even larger optical modulations than the pulse. Thus, it is desirable to reduce the movement of a pulse oximetry sensor in order to mitigate artifacts. Use of a mucoadhesive may urge the sensor into better contact with the desired site of measurement and may eliminate or reduce motion of the sensor relative to the tissue.

[0009] Alternative means of monitoring tissue constituents may also be of clinical interest. One such parameter of interest is carbon dioxide. Elevated levels of carbon dioxide in the tissue may be related to poor perfusion. Thus, assessment of carbon dioxide levels may be useful for diagnosing a variety of clinical states related to poor perfusion. One method of determining the level of blood carbon dioxide involves measuring carbon dioxide levels of respiratory gases. In relatively healthy individuals, the carbon dioxide in the bloodstream equilibrates rapidly with carbon dioxide in the lungs, the partial pressure of the carbon dioxide in the lungs approaches the amount in the blood during each breath. Accordingly, physicians often monitor respiratory gases at the end of expiration in order to estimate the carbon dioxide levels in the blood.

[0010] Respiratory gas analyzers typically function by passing electromagnetic radiation through a respiratory gas sample and measuring the absorption that is related to carbon dioxide. Often, the gas samples are collected with adapters that are fitted into patients being given respiratory assistance, for example patients under anesthesia, or patients on life support systems, to connect between the endotracheal tube (ET tube) and the ventilating tube of the breathing apparatus. These tubes convey respiratory gases to the patient and exhaled breath away from the patient. The airway adapter is in the form of a short connector of tubular shape, and is required to make a connection between the generally very different cross sections of these two tubes. Respiratory gases may also be collected through the use of cannulas, which are flexible tubes that are threaded through the mouth or nose. Respiratory gas samples collected from a cannula may be aspirated from the airway stream and exposed to a carbon dioxide sensor.

[0011] It is often inconvenient to measure carbon dioxide in respiratory gases from respiratory gas samples collected from an intubation tube or cannula. Although these methods are considered to be noninvasive, as the surface of the skin is not breached, the insertion of such devices may cause discomfort for the patient. Further, the insertion and operation of such devices also involves the assistance of skilled medical personnel.

[0012] Carbon dioxide and other physiological parameters may also be measured transcutaneously by sensors held

against a patient's skin. Transcutaneously measured carbon dioxide may also be clinically useful when compared to carbon dioxide measured in respiratory gases. For example, variations in carbon dioxide measurements between these two methods may be diagnostic for certain clinical states. While transcutaneous sensors may be easier to use than respiratory gas sensors, they also have certain disadvantages. As transcutaneous sensors depend upon the perfusion of carbon dioxide through a relatively thick epidermal layer, these sensors may not be as accurate.

[0013] Direct measurement of tissue carbon dioxide, particularly in tissues sensitive to hypoperfusion, provides clinicians with important diagnostic information regarding systemic circulation and/or onset of septic shock. The oral mucosa is a tissue involved in the visceral response to systemic hypoperfusion. A sensor held in position on the oral mucosa could provide trending information about a patient's level of systemic perfusion.

SUMMARY

[0014] Certain aspects commensurate in scope with the originally claimed invention are set forth below. It should be understood that these aspects are presented merely to provide the reader with a brief summary of certain forms the invention might take and that these aspects are not intended to limit the scope of the invention. Indeed, the invention may encompass a variety of aspects that may not be set forth below.

[0015] There is provided a sensor that includes: an indicator adapted to provide feedback related to a physiological constituent; and a mucoadhesive disposed on a tissue-contacting side of the sensor.

[0016] There is also provided a system that includes a sensor adapted to be operatively coupled to the monitor. The sensor includes: an indicator adapted to provide feedback related to a physiological constituent; and a mucoadhesive disposed on a tissue-contacting side of the sensor.

[0017] There is also provided a method of operating a sensor that includes: securing a sensor to a mucosal tissue with a mucoadhesive, wherein the sensor is adapted to provide feedback related to a physiological constituent.

[0018] There is also provided a method of manufacturing a sensor that includes: providing an indicator adapted to provide feedback related to a physiological constituent; and providing a mucoadhesive disposed on a tissue-contacting side of the sensor.

BRIEF DESCRIPTION OF THE DRAWINGS

[0019] Advantages of the invention may become apparent upon reading the following detailed description and upon reference to the drawings in which:

[0020] FIG. 1 is a schematic cross-section of a sensor showing a mucoadhesive layer according to the present invention;

[0021] FIG. 2 illustrates a perspective view of a patient using a sensor for detection of a physiological constituent according to the present invention;

[0022] FIG. 3 illustrates a side perspective view of a sensor for detection of tissue or blood constituents with a mucoadhesive region according to the present invention;

[0023] FIG. 4 illustrates a schematic cross-sectional view of the sensor of FIG. 3;

[0024] FIG. 5 illustrates cross-sectional view of a sensor for detection of tissue or blood constituents with a collection chamber according to the present invention

[0025] FIG. 6 illustrates cross-sectional view of an exemplary pulse oximetry sensor adhered to the mucous membrane according to the present invention; and

[0026] FIG. 7 illustrates a physiological constituent detection system coupled to a multi-parameter patient monitor and a sensor according to embodiments of the present invention.

DETAILED DESCRIPTION OF SPECIFIC EMBODIMENTS

[0027] One or more specific embodiments of the present invention will be described below. In an effort to provide a concise description of these embodiments, not all features of an actual implementation are described in the specification. It should be appreciated that in the development of any such actual implementation, as in any engineering or design project, numerous implementation-specific decisions must be made to achieve the developers' specific goals, for example compliance with system-related and business-related constraints, which may vary from one implementation to another. Moreover, it should be appreciated that such a development effort might be complex and time consuming, but would nevertheless be a routine undertaking of design, fabrication, and manufacture for those of ordinary skill having the benefit of this disclosure.

[0028] Sensors are provided herein that may assess the presence of physiological constituents while secured to the mucosal tissue by mucoadhesives, which provide multiple advantages. A secure mounting of the sensor to the mucosal tissue with mucoadhesives reduces movement of the sensor, which may cause signal artifacts. A sensor may be attached to mucosal tissue that is easily accessible to a healthcare worker, for example buccal tissue, which does not involve the insertion of respiratory airway tubes that may cause patient discomfort. Mucoadhesive mounting of sensors to the mucous membrane helps seal the sensor to the tissue, thus preventing tissue constituents at the sensor site from diffusing away before reaching the sensing elements of the sensor. Conversely, use of a mucoadhesive prevents oral fluids or respiratory gases from contaminating the sensor site. The term mucoadhesive refers to a substance that sticks to or adheres to the mucous membrane by any number of mechanisms, for example, but not limited to the following: hydrogen-bonding, ionic interaction, hydrophobic interaction, van der Waals interaction, or combinations thereof.

[0029] Generally, it is envisioned that a sensor according to the present technique is appropriate for use in determining the presence or levels of physiological constituents, including blood and tissue parameters. For example, carbon dioxide or other constituents may be assessed by utilization of a sensor placed directly on the mucosal surface. Thus, clinically relevant information may be ascertained and utilized for diagnostic purposes, e.g. poor tissue perfusion.

[0030] The sensor is secured to the mucosal tissue with a mucoadhesive, forming a seal to prevent the blood or tissue constituents, for example carbon dioxide, from diffusing

away. Additionally, the seal prevents movement of the sensor from altering the optical path of any spectrophotometric elements of the sensor, which may result in signal interference. The sensor may be used in the oral and nasal passages. The oral passages may include the floor of the mouth, the roof of the mouth, the soft palate, the cheeks, the gums, the lips, and any other oral tissue. Further, a sensor as described herein is appropriate for use adjacent to or proximate to any mucosal surface, i.e. patient surfaces that include a mucous membrane or surfaces that are associated with mucus production. In addition to the oral and nasal mucosa, mucosal surfaces may include respiratory, gastrointestinal or urogenital surfaces.

[0031] Sensors as provided by the present techniques may be disposable or reusable. In addition, the sensors may be appropriate for short-term (e.g. minutes) or long-term (e.g. hours, days, or longer) monitoring. In addition to carbon dioxide monitoring, sensors as provided herein may be used to monitor oxygen, ethanol, metabolic trace gases, e.g. acetone or anesthetic gases, e.g. isoflurane, halothane, desflurane, sevoflurane and enflurane that may diffuse transcutaneously. Additionally, sensors as provided herein may be useful for monitoring tissue metabolites, e.g. cytochrome a/a3, phosphomonoesters, H⁺, ATP, ADP, NADH, NAD⁺, cytokines, and inflammatory markers. Further, sensors as provided herein are appropriate for use in determination of blood oxygen saturation as well as measurement and/or analysis of other blood and/or tissue constituents using principles of pulse oximetry. For example, the present techniques may be utilized for the measurement and/or analysis of carboxyhemoglobin, methemoglobin, total hemoglobin, fractional hemoglobin, intravascular dyes, and/or water content.

[0032] FIG. 1 is a schematic view of an exemplary sensor 10 according to the present techniques. The sensor 10 has an indicator layer 12 and a mucoadhesive layer 14. When the sensor 10 is contacted with a tissue or fluid sensor site, the mucoadhesive layer 14 forms an adhesion complex with the tissue. When the sensor 10 is adhered to the mucous membrane, physiological constituents, for example blood oxygen, may be spectrophotometrically assessed, as discussed in more detail herein. In such an embodiment, the indicator layer 12 may include an emitter and detector pair. Alternatively, tissue gases for example carbon dioxide may perfuse through the mucoadhesive-tissue complex into the indicator layer 12. The indicator layer 12 may be adapted to respond to the presence of carbon dioxide, and provides a feedback, discussed in more detail below.

[0033] The mucoadhesive layer 14 may include a variety of mucoadhesive compositions to secure a sensor to mucosal tissue according to the present techniques. Suitable mucoadhesives include, but are not limited to hydroxypropyl cellulose, hydroxypropyl methylcellulose, hydroxyethylcellulose, ethylcellulose, carboxymethylcellulose, dextran, guar gum, polyvinyl pyrrolidone, pectins, starches, gelatin, casein, acrylic acid polymers, polymers of acrylic acid esters, vinyl polymers, vinyl copolymers, polymers of vinyl alcohols, alkoxy polymers, polyethylene oxide polymers, polyethers, and any combination of the above.

[0034] In specific embodiments, the mucoadhesive may be a biocompatible polymer, for example polyacrylic acid, that is cross-linked with an acceptable agent to create an

insoluble gel. The use of an insoluble gel is desirable since it remains adhered to the mucosal tissue for relatively long periods of time. Cross-linked polyacrylic acid polymers, for example Noveon and Carbomer, may be appropriate for use for three to five days or longer. Noveon and Carbomer-based polymers are weak acids and contain many negatively-charged carboxyl-groups. The multiple negative charges on these polymers promote hydrogen-bonding between the polymers and the negatively charged mucin, a glycoprotein that mediates attachment of mucus to the epithelial lining.

[0035] A mucoadhesive polymer may also include acrylic acid polymers (e.g. Carbopol® 940, also known as Carbomer® 940, Carbopol 934P and Carbopol® 980, products of BF Goodrich), methyl vinyl/maleic acid copolymers (e.g. Gantrez® S-97, a product of International Specialty Products), polyvinyl pyrrolidone also known as povidone (e.g. Plasdane® K-90, a product of International Specialty Products). These polymers impart relatively high viscosity at relatively low concentrations. They may therefore be incorporated onto a sensor in amounts ranging from about 0.01% to about 10% by weight relative to the total composition. These viscosity modifying agents further act to improve the film adhesion of the composition to mucous membranes. Carbopol® 980, in certain embodiments, may be 2-3% by weight of the total composition.

[0036] The mucoadhesive may be formulated as either a liquid or as a gel. If a liquid formulation is desired, a relatively low concentration (e.g. 0.1-1%) of the mucoadhesive/viscosity modifying agent may be used. If a gel formulation is desired, a higher concentration (e.g. 1.5-4%) of the suitable viscosity modifying/mucoadhesive agent may be incorporated into the polymethacrylate/solvent vehicle for gel formation.

[0037] The mucoadhesive may further comprise excipients e.g. plasticizers, flavorings, sweeteners and/or colorants. Examples of plasticizers include triethyl citrate, polyethylene glycol and glycerin. Such plasticizers may be present in amounts generally ranging from about 1% to about 10% by weight relative to the total composition. For example, glycerine can be present in the amount of 1-5% by weight. Polyethylene glycol and triethyl citrate can be used in the amount of about 5% to about 12%, in certain embodiments.

[0038] The indicator layer 12 may include any appropriate indicating element, including chemical, enzymatic, spectrophotometric, fluorescent, or chemiluminescent indicators. In certain embodiments, the indicator layer 12 may include sensing elements, e.g. an emitter and detector pair that may be of any suitable type. For example, the emitter may be one or more light emitting diodes adapted to transmit one or more wavelengths of light in the red to infrared range, and the detector may one or more photodetectors selected to receive light in the range or ranges emitted from the emitter. Alternatively, an emitter may also be a laser diode or a vertical cavity surface emitting laser (VCSEL). An emitter and detector may also include optical fiber sensing elements. An emitter may include a broadband or "white light" source, in which case the detector could include any of a variety of elements for selecting specific wavelengths, for example reflective or refractive elements or interferometers. These kinds of emitters and/or detectors would typically be coupled to the rigid or rigidified sensor via fiber optics.

Alternatively, a sensor may sense light detected from the tissue is at a different wavelength from the light emitted into the tissue. Such sensors may be adapted to sense fluorescence, phosphorescence, Raman scattering, Rayleigh scattering and multi-photon events or photoacoustic effects. For pulse oximetry applications using either transmission or reflectance type sensors the oxygen saturation of the patient's arterial blood may be determined using two or more wavelengths of light, most commonly red and near infrared wavelengths. Similarly, in other applications, a tissue water fraction (or other body fluid related metric) or a concentration of one or more biochemical components in an aqueous environment may be measured using two or more wavelengths of light, most commonly near infrared wavelengths between about 1,000 nm to about 2,500 nm. It should be understood that, as used herein, the term "light" may refer to one or more of ultrasound, radio, microwave, millimeter wave, infrared, visible, ultraviolet, gamma ray or X-ray electromagnetic radiation, and may also include any wavelength within the radio, microwave, infrared, visible, ultraviolet, or X-ray spectra.

[0039] Alternatively, the indicator layer **12** may include an active ingredient of the indicating element, for example the active ingredient involved in providing the required response signal when exposed to a given concentration of carbon dioxide or other constituents. The active ingredient may be any indicator that is sensitive to the presence of carbon dioxide and that is capable of being calibrated to give a response signal corresponding to a given predetermined concentration of carbon dioxide. The signal may be visual, e.g. a change in color, or electrical. Indicators which provide a color change in a presence of carbon dioxide may include chromogenic pH-sensitive indicators and oxidation/reduction indicators.

[0040] A chromogenic pH-sensitive indicator will provide a color change upon exposure to a given concentration of carbon dioxide or other metabolites in the presence of other ingredients of the element which provide the appropriate chemical conditions to induce the required color change. A chromogenic pH-sensitive indicator, e.g. a compound, or mixture of compounds, changes color when there is a change in pH in the surrounding medium. For such an indicator to be capable of giving a determination of carbon dioxide, it is typically used in combination with a suitable base which provides an alkaline solution. The hydroxyl ions or amine residues present in the alkaline solution react chemically with carbon dioxide to produce a carbonate, bicarbonate and/or carbamate moiety. The resulting reaction depletes the hydroxyl ion or amine at the interface and thus lowers the pH at the surface of the component impregnated with the indicating element. The lowering of the pH causes a color change in the indicator.

[0041] Chromogenic pH-sensitive indicators according to the present techniques may include metacresol purple, thymol blue, cresol red, phenol red, xylenol blue, a 3:1 mixture of cresol red and thymol blue, bromthymol blue, neutral red, phenolphthalein, rosolic acid, alpha-naphtholphthalein and orange I. Examples of other indicators which may be used include bromcresol purple, bromphenol red, p-nitrophenol, m-nitrophenol, curcumin, quinoline blue, thymolphthalein and mixtures thereof. Suitable bases include sodium carbonate, lithium hydroxide, sodium hydroxide, potassium hydroxide, potassium carbonate, sodium barbitol, tribasic

sodium phosphate, dibasic sodium phosphate, potassium acetate, monoethanolamine, diethanolamine and piperidine.

[0042] The indicator layer **12** may also include an enzyme-based detection system. For example, one such enzyme may be carbonic anhydrase, which is an enzyme that assists interconversion of carbon dioxide and water into carbonic acid, protons, and bicarbonate ions. As described above, this reaction lowers the pH at the surface of the component impregnated with the indicating element. The lowering of the pH may cause a color change in the indicator. Another such enzyme-based detection system is an enzyme linked immunosorbent assay (ELISA). For example, such an assay may be appropriate when assessing tissue proteins. Thus, the indicator element may include a primary antibody specific for the tissue protein of interest, and a labeled secondary binding ligand or antibody, or a secondary binding ligand or antibody in conjunction with a labeled tertiary antibody or third binding ligand. The label may be an enzyme that will generate color development upon incubating with an appropriate chromogenic substrate. Suitable enzymes include urease, glucose oxidase, alkaline phosphatase or hydrogen peroxidase.

[0043] A chemical indicator may be used in conjunction with an electrical or electronic device that is adapted to detect and measure changes in the ambient chemical parameters induced by the presence of critical amounts of carbon dioxide. For example, optical fiber carbon dioxide sensors may be used to convert a change in a chemical indicator to a quantitative measurement of carbon dioxide in the sample. Generally, such sensors operate by directing light of a predetermined wavelength from an external source through the optical fiber to impinge the chemical indicator. The intensity of the emitted fluorescent light returning along the fiber is directly related to the concentration of carbon dioxide in the sample, as a result of the pH-sensitive indicator material present at the fiber tip (i.e., the pH of the indicator solution is directly related to carbon dioxide concentration, as a result of carbonic acid formation). The emitted light is carried by the optical fiber to a device where it is detected and converted electronically to a carbon dioxide concentration value. The sensor may additionally have a reference dye present in the indicator composition. The intensity of the light emitted from the reference dye may be used to compensate, via rationing, the signal obtained from the indicator. Other components may be incorporated into the indicator composition including surfactants, antioxidants and ultraviolet stabilizers may also be present in the indicator composition.

[0044] The indicator layer **12** may be formed from any appropriate substrate. For example, the indicator layer **12** may be filter paper, which may be soaked in, dipped in, or otherwise exposed to the appropriate carbon dioxide-sensing compounds. In certain embodiments, the filter paper may be dipped into a solution containing the indicating compounds on only one side. The indicator layer **12** may also be polysulfone, polypropylene, or other polymer substrates. The indicator layer **12** may be a thin film, or a thicker substrate. A thicker substrate may lead to a slower response time, which may be advantageous in situations in which a sensor is monitoring carbon dioxide levels over a longer period of time. Additionally, the indicator layer **12** may have pores of a variety of sizes.

[0045] In specific embodiments, it may be advantageous to provide a sensor for use on buccal or sublingual tissue that is easily reached by the patient or a healthcare worker. For example, FIG. 2 illustrates the placement of a sensor with a mucoadhesive on a buccal surface in order to assess a tissue gas, for example carbon dioxide, in the tissue, blood or interstitial fluid. Specifically, FIG. 2 shows an embodiment of a sensor 10 including an output cable 16 that is adapted to provide an electrical feedback. Alternatively, reference number 16 may represent a string, cord, or tether that facilitates removal of the sensor 10. In another embodiment, reference number 16 may represent a gas collection tube. In such an embodiment, the sensor 10 may collect tissue gases in a chamber. The collected gases may then diffuse through a tube connected to the collection chamber, and the gases may then be further assessed and/or measured by sensing elements not directly applied to the patient. The sensor 10 may be suitably sized and shaped such that a patient may easily close his or her mouth around the sensor with minimal discomfort.

[0046] The sensor 10 is secured to the buccal tissue 18 such that the area covered by the sensor 10 is substantially sealed to prevent air flow out of the sensor 10, thus preventing carbon dioxide at the sensor placement site from dissipating into the airstream, which may lead to inaccurate measurements. Further, the sensor's 10 tissue seal may also prevent respiratory gases or oral fluids from entering the sensor 10. Generally, the sensor 10 may be suitably sized and shaped to allow the sensor 10 to be positioned flush against the buccal tissue 18.

[0047] FIG. 3 is a perspective view of an exemplary sensor 10A. The sensor 10A includes a housing 20 surrounding an indicator layer 22. The housing is formed to provide a surface 24 that is suitably shaped to be secured against a mucosal tissue. Mucoadhesive 26 is disposed on the surface 24. The mucoadhesive 26 may include a substrate holder, for example a paper or foam. In such an embodiment, the paper or foam is soaked in or otherwise impregnated with the mucoadhesive 26 in the form of a gel or liquid.

[0048] The mucoadhesive 26 is disposed on the sensor 10A in a ring substantially surrounding the indicator layer 22. Thus, when the sensor 10A is applied to tissue, the mucoadhesive 26 adheres in a region of tissue adjacent to the indicator layer 22, such that the indicator layer 22 is in direct contact with the mucous membrane. In certain embodiments, the mucoadhesive 26 is permeable to the tissue gases being measured. In such an embodiment, the mucoadhesive 26 may be applied directly to the sensor placement site on the tissue by a healthcare worker. Thus, the mucoadhesive 26 would be disposed between the mucous membrane and the indicator layer 22, and the tissue carbon dioxide or other constituents would perfuse through the mucoadhesive 26 before reaching the indicator layer 22. Such an arrangement may be advantageous if the mucoadhesive 26 must be freshly prepared prior to use, and cannot be stored with the sensor 10A.

[0049] In other embodiments (not shown), it may be advantageous to package the sensor in foil or other protective materials in order to protect the mucoadhesive 26 prior to use, and prevent drying out or oxidation of the mucoadhesive 26 layer.

[0050] The housing 20 may be any suitable material that is generally suited to the aqueous environment of the

mucous membrane, for example plastic. In certain embodiments, the housing 20 may be any suitable optically transparent material that allows for viewing of the indicator layer 22 beneath. Exemplary materials include transparent polymers, for example polypropylene or polyethylene terephthalate (PET). In other embodiments, the housing 20 may be an opaque material with a transparent window that allows viewing of the indicator layer 22. However, in other embodiments in which the sensor 10A is adapted to provide electrical feedback to a monitor, the sensor 10A may or may not include a mechanism for viewing a color change of the indicator layer 20.

[0051] FIG. 4 is a schematic view of the exemplary sensor 10A that includes a permeable substrate 28 disposed in the tissue-contacting side of the indicator layer 22. A permeable substrate 28 may be advantageous in providing rigidity and support to the sensor assembly 10A. Suitable materials for a permeable substrate 28 include, but are not limited to paper, plastics, or woven materials. Carbon dioxide or other constituents 30 at the surface of the mucosal tissue contacts the permeable substrate 28 when the sensor assembly is applied to a mucosal surface. The substrate 28 is permeable to carbon dioxide or other constituents 30, which diffuses to contact the indicator layer 22. A transparent window 32 allows viewing of the response, for example a change in color of the indicator layer 22.

[0052] FIG. 5 is an alternate embodiment of a tissue constituent sensor 10B in which the sensor includes an electrical indicator. A housing 34 is adhered to the mucosal tissue 48 by a mucoadhesive 44. The housing 34, once adhered, forms a collection chamber that traps tissue gas 46 that diffuses through the mucosal tissue 48. The trapped tissue gas 46 may then be irradiated by an emitter 38, and the emitted light that passes through the tissue gas 46 is detected by a detector 40. The emitter 38 and the detector 40 are electrically coupled to a cable 36 by a pair of wires 42. The wavelength of the light emitted by the emitter 38 and the detection range of the detector 40 may be selected to detect a wide range of tissue gases 46, including carbon dioxide.

[0053] The housing 34 may be formed from polypropylene, polyethylene, polysulfone or similar polymers. Generally, the housing should be relatively impermeable to tissue gases, such that the sensor 10B may collect tissue gases 46 for a sufficient period of time to allow for detection and measurement. Hence, it may be advantageous to coat the sensor 10B with additional sealants to prevent leakage of the tissue gases 46.

[0054] In certain embodiments, the emitter 38 may be an infrared light source, for example an incandescent broad band lamp, (available from Oshino Lamps). In such an embodiment, the sensor may also include an infrared detector 40, for example a lead selenide detector (available from OptoElectronics). The emitter may also include a filter, for example a 4.26 micron wavelength filter. Such a filter may be appropriate for use in an embodiment where carbon dioxide is measured.

[0055] In some embodiments, the sensor 10B is arranged to operate in transmission mode, and casings for the emitter and detector may be formed in the housing 34 on opposite sides of the sensor 10B. In an alternate embodiment, the emitter 38 and the detector 40 may be arranged to operate in reflectance mode (not shown), and can be located on the

same side of sensor 10B. In such an embodiment (not shown), a mirror may be placed on the opposite side of the housing 34 to reflect the radiation emitted from the emitter 38 back to the detector 40.

[0056] FIG. 6 illustrates an exemplary reflectance pulse oximetry sensor 10C. The sensor 10C has an indicator layer that includes a sensor body 56 and an emitter 58 and a detector 60 that generally lie side-by-side. The sensor 10C is adhered to the mucous membrane 66 with a mucoadhesive 64. The sensor 10C is arranged such that the emitter 58 emits light, represented by arrow 62 that is absorbed and/or scattered back to the detector 60. The emitter 58 and the detector 60 may be disposed on the sensor body 56, which may be made of any suitable material, for example plastic, foam, woven material, or any water-resistant material. Alternatively, the emitter 58 and the detector 60 may be remotely located and optically coupled to the sensor 10C using optical fibers. In an alternative embodiment (not shown), the sensor 10C may be a transmission type sensor. Transmission type sensors include an emitter 58 and detector 60 that are typically placed on opposing sides of the sensor site. Thus, part of the sensor may be adhered to the mucous membrane of the cheek with a mucoadhesive 64 and a part of the sensor may be adhered to the exterior portion of the cheek with other suitable adhesives, such that the emitter 58 and the detector 60 are positioned on opposite sides of the cheek. In other words, the sensor 10C is positioned so that the emitter 58 is located on the interior of patient's mouth and the detector 60 is located 180° opposite the emitter 58 on the exterior of the patients mouth. In such an arrangement, a conformable sensor body 56 may connect the emitter 58 and the detector 60. In each of the embodiments discussed herein, it should be understood that the locations of the emitter 58 and the detector 60 may be exchanged. In either arrangement, the sensor 10C will perform in substantially the same manner.

[0057] The exemplary sensors described herein, illustrated here generically as a sensor 10, may be coupled to a monitor 50, for example a carbon dioxide monitor or a pulse oximetry monitor, that may display the concentration of a physiological constituent in the patient sample (e.g. mucosal tissue or blood) as shown in FIG. 7. It should be appreciated that the cable 52 of the sensor 10 may be coupled to the monitor 50 or it may be coupled to a transmission device (not shown) to facilitate wireless transmission between the sensor 10 and the monitor 50. The monitor 50 may be any suitable carbon dioxide monitor, for example those available from Nellcor Puritan Bennett Inc. Furthermore, to upgrade conventional carbon dioxide detection provided by the monitor 50 to provide additional functions, the monitor 50 may be coupled to a multi-parameter patient monitor 54 via a cable 56 connected to a sensor input port or via a cable 58 connected to a digital communication port.

[0058] While the invention may be susceptible to various modifications and alternative forms, specific embodiments have been shown by way of example in the drawings and have been described in detail herein. However, it should be understood that the invention is not intended to be limited to the particular forms disclosed. Indeed, the present techniques may not only be applied to measurements of carbon dioxide, but these techniques may also be utilized for the measurement and/or analysis of other blood or tissue constituents. Rather, the invention is to cover all modifications,

equivalents, and alternatives falling within the spirit and scope of the invention as defined by the following appended claims. It will be appreciated by those working in the art that sensors fabricated using the presently disclosed and claimed techniques may be used in a wide variety of contexts. That is, while the invention has primarily been described in conjunction with the measurement of physiological constituents in the blood or tissue, the sensors fabricated using the present method may be used to evaluate any number of sample types in a variety of industries, including fermentation technology, cell culture, and other biotechnology applications.

What is claimed is:

1. A sensor comprising:

an indicator adapted to provide feedback related to a physiological constituent; and

a mucoadhesive disposed on a tissue-contacting side of the sensor.

2. The sensor, as set forth in claim 1, wherein the mucoadhesive comprises an acrylic acid polymer, a methyl vinyl copolymer, or a polyvinyl pyrrolidone.

3. The sensor, as set forth in claim 1, wherein the mucoadhesive comprises a liquid or a gel.

4. The sensor, as set forth in claim 1, wherein the physiological constituent comprises at least one of a tissue or blood constituent.

5. The sensor, as set forth in claim 1, wherein the physiological constituent comprises at least one of a metabolic trace gases or an anesthetic gas.

6. The sensor, as set forth in claim 1, wherein the physiological constituent comprises at least one tissue metabolite.

7. The sensor, as set forth in claim 1, wherein the physiological constituent comprises at least one of carboxy-hemoglobin or methemoglobin,

8. The sensor, as set forth in claim 1, wherein the sensor comprises at least one of a pulse oximetry sensor or a carbon dioxide sensor.

9. The sensor, as set forth in claim 1, wherein the indicator comprises a carbon dioxide-sensitive chemical compound.

10. The sensor, as set forth in claim 1, comprising an optically transparent layer disposed on the indicator.

11. The sensor, as set forth in claim 1, wherein the indicator comprises an emitter and a detector.

12. The sensor, as set forth in claim 1, wherein the mucoadhesive is adapted to degrade over time.

13. The sensor, as set forth in claim 1, wherein the mucoadhesive is adapted to dissolve upon contact with a solvent.

14. The sensor, as set forth in claim 1, comprising a removable substrate disposed on a tissue-contacting surface of the sensor.

15. A system comprising:

a monitor; and

a sensor adapted to be operatively coupled to the monitor, the sensor comprising:

an indicator adapted to provide feedback related to a physiological constituent; and

a mucoadhesive disposed on a tissue-contacting side of the sensor.

16. The system, as set forth in claim 15, wherein the mucoadhesive comprises an acrylic acid polymer, a methyl vinyl copolymer, or a polyvinyl pyrrolidone.

17. The system, as set forth in claim 15, wherein the mucoadhesive comprises a liquid or a gel.

18. The system, as set forth in claim 15, wherein the physiological constituent comprises at least one of a tissue or blood constituent.

19. The system, as set forth in claim 15, wherein the physiological constituent comprises at least one of a metabolic trace gases or an anesthetic gas.

20. The system, as set forth in claim 15, wherein the physiological constituent comprises at least one tissue metabolite.

21. The system, as set forth in claim 15, wherein the physiological constituent comprises at least one of carboxy-hemoglobin or methemoglobin.

22. The system, as set forth in claim 15, wherein the sensor comprises at least one of a pulse oximetry sensor or a carbon dioxide sensor.

23. The system, as set forth in claim 15, wherein the indicator comprises a carbon dioxide-sensitive chemical compound.

24. The system, as set forth in claim 15, comprising an optically transparent layer disposed on the indicator.

25. The system, as set forth in claim 15, wherein the indicator comprises an emitter and a detector.

26. The system, as set forth in claim 15, wherein the mucoadhesive is adapted to degrade over time.

27. The system, as set forth in claim 15, wherein the mucoadhesive is adapted to dissolve upon contact with a solvent.

28. The system, as set forth in claim 15, comprising a removable substrate disposed on a tissue-contacting surface of the sensor.

29. A method comprising:

securing a sensor to a mucosal tissue with a mucoadhesive, wherein the sensor is adapted to provide feedback related to a physiological constituent.

30. The method, as set forth in claim 29, wherein the physiological constituent comprises at least one of a tissue or blood constituent.

31. The method, as set forth in claim 29, wherein the physiological constituent comprises at least one of a metabolic trace gases or an anesthetic gas.

32. The sensor, as set forth in claim 29, wherein the physiological constituent comprises at least one tissue metabolite.

33. The sensor, as set forth in claim 29, wherein the physiological constituent comprises at least one of carboxy-hemoglobin or methemoglobin,

34. The method, as set forth in claim 29, wherein the sensor comprises at least one of a pulse oximetry sensor or a carbon dioxide sensor.

35. The method, as set forth in claim 34, comprising assessing the presence of carbon dioxide by viewing an indicator through an optically transparent layer.

36. The method, as set forth in claim 34, comprising assessing the presence of carbon dioxide by providing an electrical feedback.

37. The method, as set forth in claim 29, comprising detaching the sensor by applying a solvent to the mucosal tissue.

38. A method of manufacturing a sensor, comprising:

providing an indicator adapted to provide feedback related to a physiological constituent; and

providing a mucoadhesive disposed on a tissue-contacting side of the sensor.

39. The method, as set forth in claim 38, comprising:

providing an optically transparent layer disposed on the indicator.

40. The method, as set forth in claim 38, wherein the indicator comprises a carbon dioxide-sensitive chemical compound.

41. The method, as set forth in claim 38, wherein the indicator comprises an emitter and a detector.

42. The method, as set forth in claim 38, wherein the mucoadhesive comprises an acrylic acid polymer, a methyl vinyl copolymer, or a polyvinyl pyrrolidone.

43. The method, as set forth in claim 38, wherein the mucoadhesive comprises a liquid or a gel.

44. The method, as set forth in claim 38, wherein the physiological constituent comprises at least one of a tissue or blood constituent.

45. The method, as set forth in claim 38, wherein the physiological constituent comprises at least one of a metabolic trace gases or an anesthetic gas.

46. The sensor, as set forth in claim 38, wherein the physiological constituent comprises at least one tissue metabolite.

47. The sensor, as set forth in claim 38, wherein the physiological constituent comprises at least one of carboxy-hemoglobin or methemoglobin,

48. The method, as set forth in claim 38, wherein the sensor comprises at least one of a pulse oximetry sensor or a carbon dioxide sensor.

49. The method, as set forth in claim 38, comprising

providing a removable substrate disposed on a tissue-contacting surface of the sensor.

* * * * *

专利名称(译)	用于评估组织和血液成分的粘膜传感器及其使用技术		
公开(公告)号	US20070078318A1	公开(公告)日	2007-04-05
申请号	US11/241724	申请日	2005-09-30
[标]申请(专利权)人(译)	KLING CARL 香农·坎贝尔		
申请(专利权)人(译)	KLING CARL 香农·坎贝尔		
当前申请(专利权)人(译)	COVIDIEN LP		
[标]发明人	KLING CARL CAMPBELL SHANNON		
发明人	KLING, CARL CAMPBELL, SHANNON		
IPC分类号	A61B5/00		
CPC分类号	A61B5/14539 A61B5/14542 A61B5/14552 A61B5/1459 Y10T29/49117 A61B5/682 A61B5/6833 A61B2562/146 A61B5/6819		
其他公开文献	US8233954		
外部链接	Espacenet USPTO		

摘要(译)

用于生理成分检测的传感器可以适于包括粘膜粘附剂。提供适用于粘膜组织的传感器。粘膜粘附剂提供了将传感器保持在粘膜上的机制，以测量组织和血液中的生理成分水平。

