



US 20040193074A1

(19) **United States**

(12) **Patent Application Publication**
Dempster et al.

(10) **Pub. No.: US 2004/0193074 A1**

(43) **Pub. Date: Sep. 30, 2004**

(54) **AIR CIRCULATION APPARATUS AND
METHODS FOR PLETHYSMOGRAPHIC
MEASUREMENT CHAMBERS**

Publication Classification

(51) **Int. Cl.⁷ A61B 5/103; G01F 17/00**

(52) **U.S. Cl. 600/587; 73/149**

(76) **Inventors: Philip T. Dempster**, Concord, CA
(US); **Michael V. Homer**, Oakland, CA
(US); **Mark Lowe**, Danville, CA (US)

(57) **ABSTRACT**

Correspondence Address:
FISH & NEAVE
1251 AVENUE OF THE AMERICAS
50TH FLOOR
NEW YORK, NY 10020-1105 (US)

Apparatus and methods relating to circulation of air within a plethysmographic measurement chamber are provided. An air circulation system, comprised of one or more pumps, is coupled to a plethysmographic measurement chamber using one or more inlet and exhaust tubes. The air circulation system renews the air within the measurement chamber using ambient air, or air derived from a controlled temperature environment.

(21) **Appl. No.: 10/402,225**

(22) **Filed: Mar. 26, 2003**

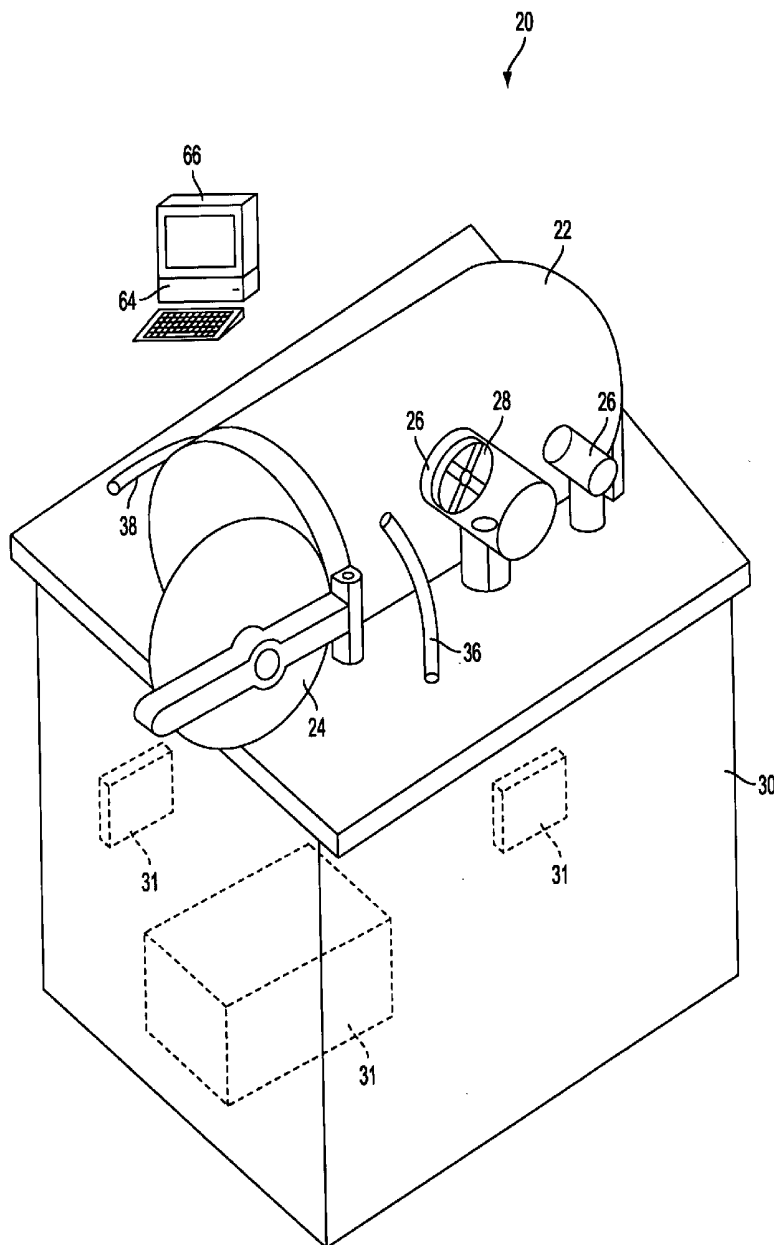

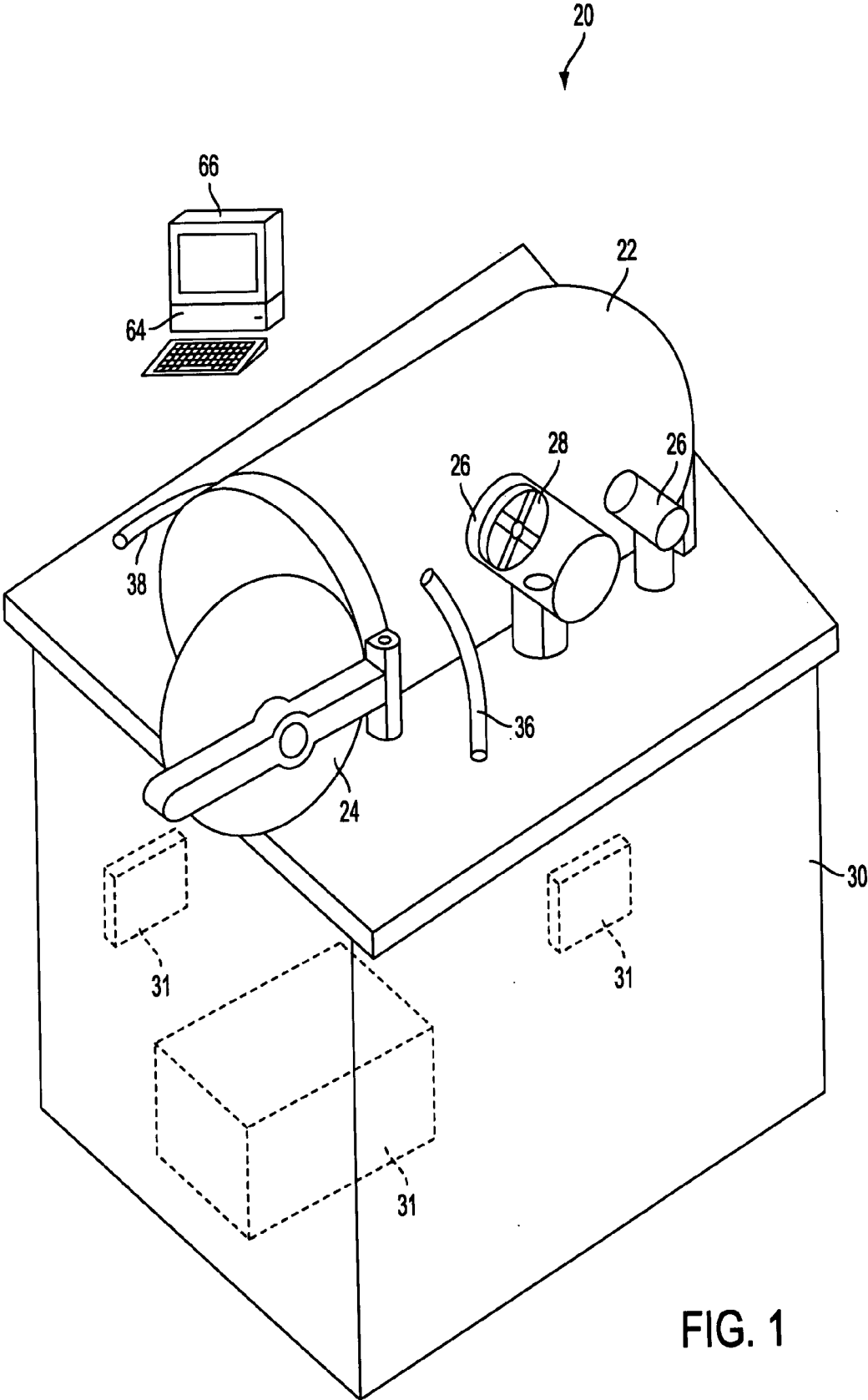

FIG. 1

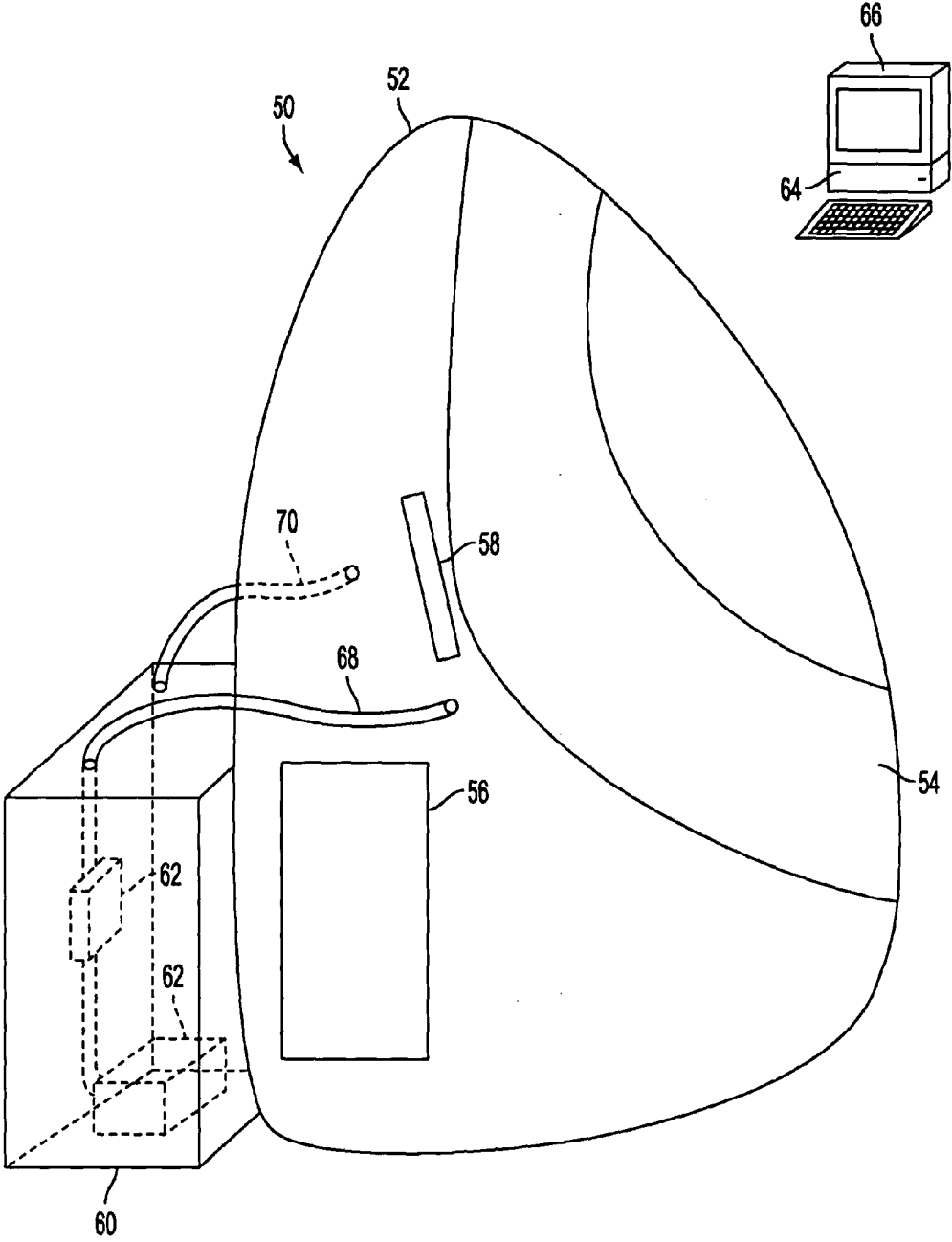

FIG. 2

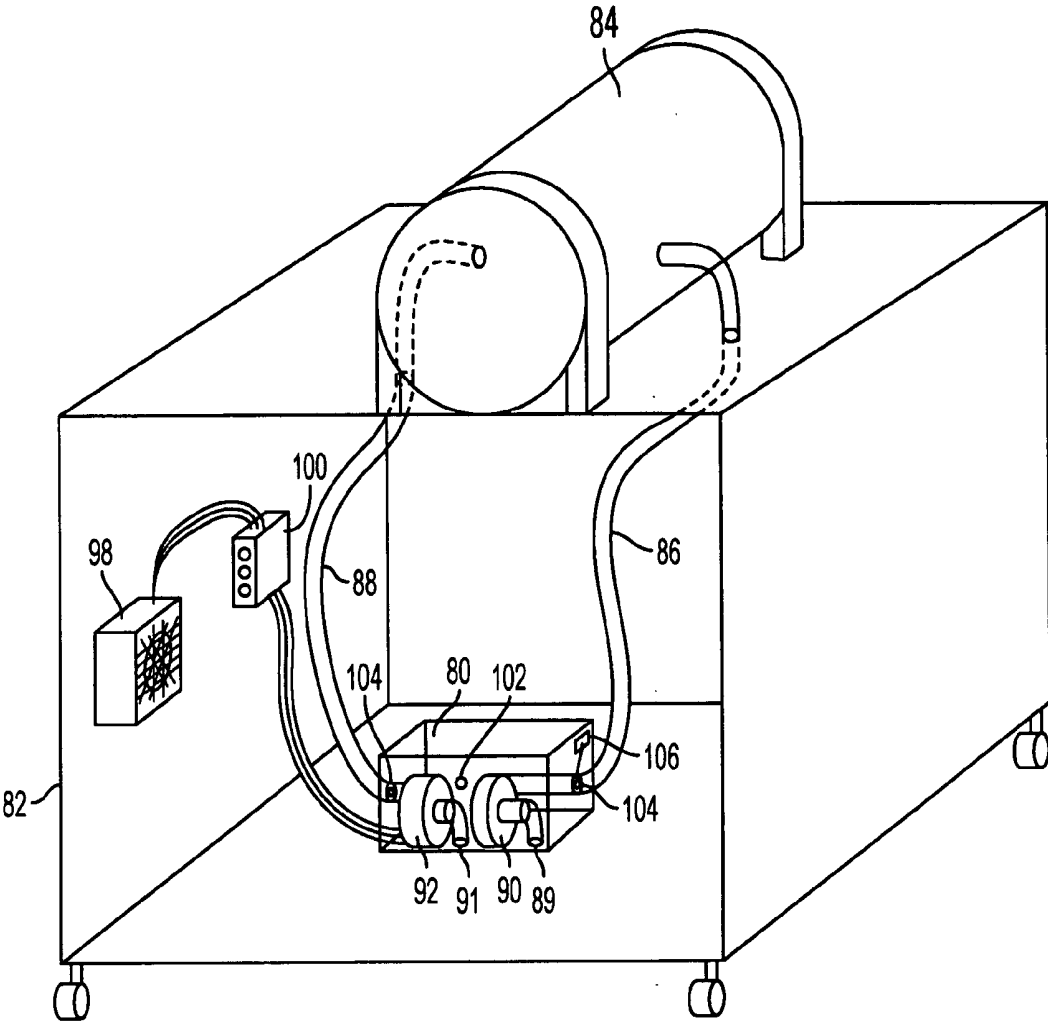

FIG. 3

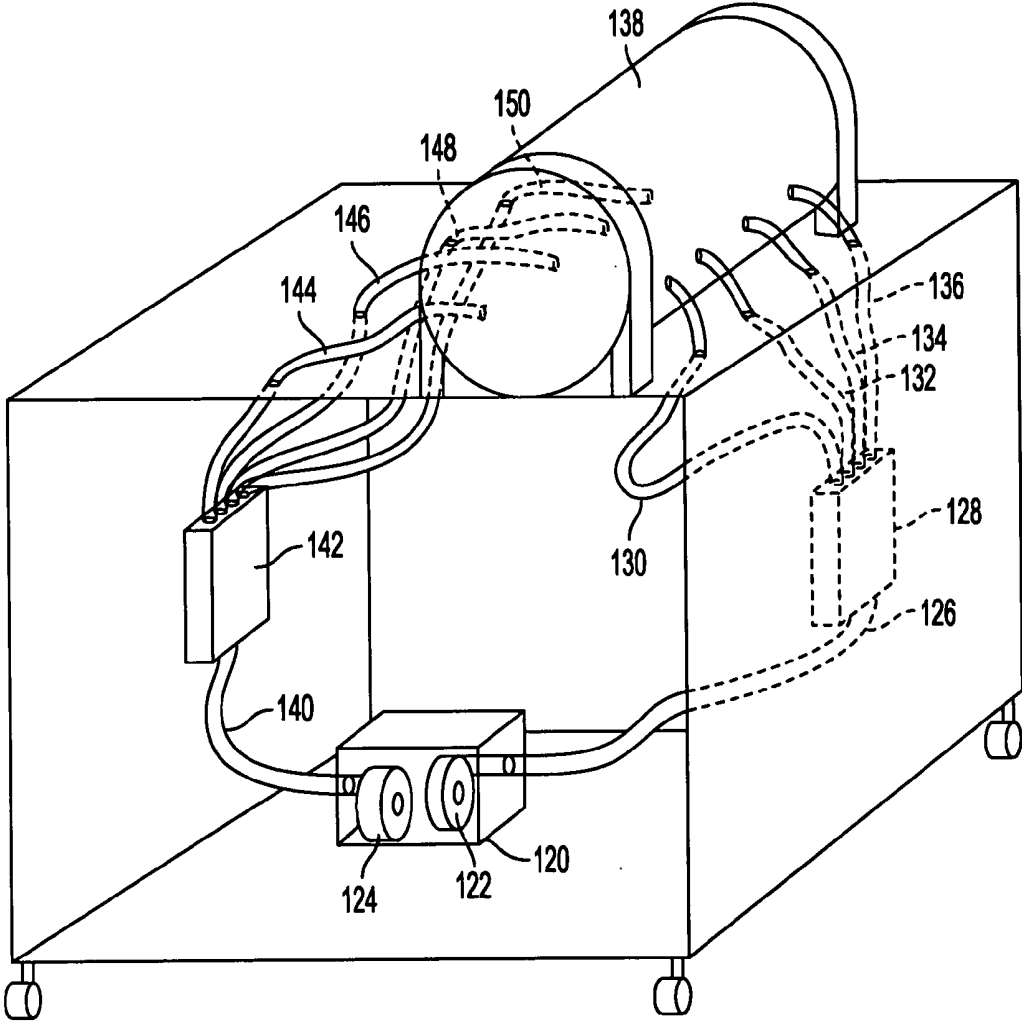

FIG. 4

AIR CIRCULATION APPARATUS AND METHODS FOR PLETHYSMOGRAPHIC MEASUREMENT CHAMBERS

FIELD OF THE INVENTION

[0001] This invention relates generally to apparatus and methods for providing accurate measurement of human body composition using a plethysmographic measurement chamber. More specifically, the present inventions relate to apparatus and methods for plethysmographic measurement of human subjects in which air within a plethysmographic measurement chamber is circulated and renewed with air from outside the chamber.

BACKGROUND OF THE INVENTION

[0002] The assessment of body composition, including measurement of fat and fat-free mass, provides physicians with important information regarding physical status. Excess body fat has been associated with a variety of disease processes, such as cardiovascular disease, diabetes, hypertension, hyperlipidemia, kidney disease, and musculoskeletal disorders. Low levels of fat free mass have been found to be critically adverse to the health of certain at-risk populations, such as infants, the obese, and the elderly.

[0003] Similarly, body composition has been shown to be useful as a diagnostic measurement for the assessment of physical status. Disturbances in health and growth, regardless of origin, almost always affect body composition in newborns and infants. For example, for very low birth weight infants, body composition and variation in body composition are relevant both in determining infant energy needs and in evaluation of health progression and physical development.

[0004] A variety of methods are currently used in the assessment of body composition. One common method is a skin fold measurement, typically performed using calipers that compress the skin at certain points on the body. While non-invasive, this method suffers from poor accuracy on account of variations in fat patterning, misapplication of population specific prediction equations, improper site identification for compressing the skin, poor fold grasping, and the necessity for significant technician training to administer the test properly.

[0005] Another method employed is bioelectric impedance analysis ("BIA"). Bioelectric impedance measurements rely on the fact that the body contains intracellular and extracellular fluids that conduct electricity. In particular, BIA involves passing a high frequency electric current through the subject's body, determining the subjects' measured impedance value, and calculating body composition based on the subject's measured impedance and known impedance values for human muscle tissue. However, this method can be greatly affected by the state of hydration of the subject, and variations in temperature of both the subject and the surrounding environment. Moreover, BIA has not been successfully applied with infant subjects.

[0006] The most common method used when precision body composition measurements are required is hydrostatic weighing. This method is based upon the application of Archimedes principle, and requires weighing the subject on

land, repeated weighing under water, and an estimation of air present in the lungs of the subject using gas dilution techniques. However, hydrodensitometry is time consuming, typically unpleasant for the subjects, requires both significant subject participation and considerable technician training and, due to the necessary facilities for implementation, is unsuitable for clinical practice. Further, the application of hydrodensitometry to infant, elderly, and disabled populations is precluded by the above concerns.

[0007] One technique offering particular promise in performing body mass measurement is the use of air displacement plethysmography. Air displacement plethysmography determines the volume of a subject to be measured by measuring the volume of air displaced by the subject in an enclosed chamber. Volume of air in the chamber is calculated through application of Boyle's Law and/or Poisson's Law to conditions within the chamber. More particularly, in the most prevalent method of air displacement plethysmography used for measuring human body composition (such as disclosed in U.S. Pat. No. 4,369,652, issued to Gundlach, and U.S. Pat. No. 5,105,825, issued to Dempster), volume perturbations of a fixed frequency of oscillation are induced within a measurement chamber, which perturbations lead to pressure fluctuations within the chamber. The amplitude of the pressure fluctuations is determined, and used to calculate the volume of air within the chamber using Boyle's Law (defining the relationship of pressure and volume under isothermal conditions) or Poisson's law (defining the relationship of pressure and volume under adiabatic conditions). Body volume is then calculated indirectly by subtracting the volume of air remaining inside the chamber when the subject is inside from the volume of air in the chamber when it is empty.

[0008] Once the volume of the subject is known, body composition can be calculated based on the measured subject volume, weight of the subject, and subject surface area (which, for human subjects, is a function of subject weight and subject height), using known formulas defining the relationship between density and human fat mass. For example, Siri's equation defines fat mass as

$$\text{Percent Fat Mass} = ((4.95/\text{Density}) - 4.5) * 100$$

[0009] where Density is defined as

$$\text{subject weight}/\text{subject volume.}$$

[0010] Similarly, Brozek's equation defines fat mass as

$$\text{Percent Fat mass} = ((4.57/\text{Density}) - 4.142) * 100$$

[0011] where Density is defined as

$$\text{subject weight}/\text{subject volume.}$$

[0012] In contrast to hydrodensitometry, air displacement plethysmographic methods generally do not cause anxiety or discomfort in the subject, and due to the ease and non-invasiveness of the technique, can be applied to subjects for whom hydrodensitometry is impractical. For example, co-pending U.S. patent application Ser. No. 10/036,139, entitled Apparatus And Methods For Plethysmographic Measurement of Infant Body Composition, applied for by Philip Dempster, and filed on Dec. 31, 2001, describes apparatus and methods for plethysmographic measurement of body composition of infant subjects.

[0013] However, plethysmographic systems require very accurate measurements of volume to yield valid body com-

position results. In particular, plethysmographic measurement of infant body composition requires even more accurate measurement of volume given the higher metabolic activity of infant subjects as a proportion of body size, and the longer measurement periods required for infants on account of larger breathing artifacts. Due to this required accuracy of volume measurement, current plethysmographic measurement systems, while effective at measuring the volume of inanimate objects, have suffered from secondary effects that limit the accuracy of those systems with human subjects. For example, accumulation of water vapor and CO₂ in the measurement chamber can significantly affect results on account of the differing adiabatic compression properties of triatomic gasses (such as CO₂ and H₂O) and diatomic gasses (such as O₂ and N₂). Similarly, variations in chamber temperature due to body heat produced by a test subject may also affect the accuracy of volume measurement.

[0014] Further, the composition of air within the measurement chamber has an effect on the comfort and safety of the test subject. Specifically, accumulation of CO₂ beyond certain levels may adversely affect the infant subject. Thus, current plethysmographic systems that do not account for accumulation of triatomic gasses tend to be less suitable for determining infant body composition.

[0015] In view of the foregoing, it would be desirable to provide a plethysmographic measurement chamber that prevented the accumulation of water vapor and CO₂ in the chamber, resulting in improved accuracy of body composition measurement.

[0016] It would further be desirable to provide a plethysmographic measurement chamber and air circulation system that addressed variations in chamber temperature on account of body heat produced by the test subject.

[0017] It would further be desirable to provide a plethysmographic measurement chamber and air circulation system that maintained a safe and comfortable air composition for infant test subjects.

SUMMARY OF THE INVENTION

[0018] In view of the foregoing, it is an object of the present invention to provide a plethysmographic measurement chamber that prevents the accumulation of water vapor and CO₂ in the chamber.

[0019] It is another object of the present invention to provide a plethysmographic measurement chamber that addressed variations in chamber temperature on account of body heat produced by the test subject.

[0020] It is another object of the present invention to provide a plethysmographic measurement chamber and air circulation system that maintains a safe and comfortable air composition for infant test subjects.

[0021] These and other objects of the present invention are accomplished by providing systems and methods for circulating and renewing air within a plethysmographic measurement chamber, while maintaining the acoustic properties of the measurement chamber at the perturbation frequency used to conduct volume measurements.

[0022] The present invention generally consists of a plethysmographic measurement system that includes an air

circulation system. The air circulation system comprises a pump assembly of one or more pumps coupled to the measurement chamber via one or more inlet tubes and one or more exhaust tubes. The lengths of the inlet tube(s) and exhaust tube(s) are selected such that the acoustic properties of the measurement chamber are not affected by the air circulation system.

[0023] In one embodiment of the present invention, the source of air for the air circulation system is a controlled temperature environment, such that chamber temperature can be maintained relatively constant in spite of body heat produced by the test subject.

[0024] In another embodiment of the present invention, the inlet tube and exhaust tube further comprise multiple parallel tubes to provide for quieter, laminar flow within the tubes.

[0025] In another embodiment of the present invention, a single inlet tube and a single exhaust tube are coupled between the pump assembly and an inlet manifold and exhaust manifold, respectively. The inlet manifold and exhaust manifold are then coupled to the chamber via multiple parallel tubes, providing for less flow resistance than full lengths of multiple parallel tubes, while still attenuating noise generated by turbulent flow.

BRIEF DESCRIPTION OF THE DRAWINGS

[0026] The foregoing and other objects of the present invention will be apparent upon consideration of the following detailed description, taken in conjunction with the accompanying drawings, in which like reference characters refer to like parts throughout, and in which:

[0027] **FIG. 1** is a representation of an infant sized plethysmographic chamber and air circulation system of the present invention.

[0028] **FIG. 2** is a representation of an adult sized plethysmographic chamber and air circulation system of the present invention.

[0029] **FIG. 3** is a detailed view of one embodiment the air circulation components of the present invention.

[0030] **FIG. 4** is a detailed view of another embodiment of the air circulation components of the present invention.

DETAILED DESCRIPTION OF THE INVENTION

[0031] Referring to **FIG. 1**, a representational view of the infant sized plethysmographic measurement chamber and air circulation system is shown. Plethysmographic system **20** is composed of plethysmographic measurement chamber **22**, chamber door assembly **24**, plethysmographic measurement components **26** (including volume perturbation element **28**, and air circulation component chamber **30**). Air circulation component chamber **30** houses air circulation components **31**, which provide the mechanism for air circulation within chamber **22**.

[0032] Plethysmographic measurement components **26** are coupled to computer **32**, which includes software **34** for controlling the operation of plethysmographic measurement components **26**.

[0033] Air circulation component chamber 30 is coupled to measurement chamber 22 via inlet tube 36 and exhaust tube 38. Inlet tube 36 and exhaust tube 38 allow for air to be continuously circulated and renewed within measurement chamber 22 through the operation of air circulation components 31. As described in more detail in connection with preferred embodiments of the invention, inlet tube 36 and exhaust tube 38 could comprise multiple parallel tubes in accordance with the present invention. Such an arrangement would result in quieter, laminar flow within the tubes, thereby generating less acoustic noise, at the expense of increased flow resistance.

[0034] Referring to FIG. 2, a representational view of an adult sized plethysmographic measurement chamber and air circulation system is shown. Plethysmographic system 50 is composed of plethysmographic measurement chamber 52, chamber door 54, plethysmographic measurement components 56 (including volume perturbation element 58), and air circulation component chamber 60, which houses air circulation components 62. Plethysmographic measurement components 56 are coupled to computer 64, which includes software 66 for controlling the operation of plethysmographic measurement components 56.

[0035] Air circulation component chamber 60 is coupled to measurement chamber 52 via inlet tube 68 and exhaust tube 70. Inlet tube 68 and exhaust tube 70 allow for air to be continuously renewed and circulated within measurement chamber 52 by air circulation components 62. As described in more detail in connection with preferred embodiments of the invention, inlet tube 68 and exhaust tube 70 could comprise multiple parallel tubes in accordance with the present invention.

[0036] One of ordinary skill in the art would understand that air circulation component chamber 60 could alternatively be housed within measurement chamber 52, so long as air circulation components 62 had access to ambient air outside of measurement chamber 52.

[0037] Referring now to FIG. 3, a view of one embodiment of the air circulation components of the present invention is described. Pump assembly 80 (shown housed within air circulation component chamber 82) is coupled to measurement chamber 84 via inlet tube 86 and exhaust tube 88. Pump assembly 80 both pumps ambient air through inlet tube 86 into measurement chamber 84, and pumps air contaminated with triatomic gasses (such as water vapor and CO₂) out of measurement chamber 84 through exhaust tube 88. Thus, air is continuously circulated and renewed within measurement chamber 84, preventing buildup of triatomic gasses that could affect the accuracy of plethysmographic measurement.

[0038] While in a preferred embodiment pump assembly 80 is housed within air circulation component chamber 82, one of ordinary skill in the art would recognize that pump assembly 80 could be physically located anywhere in relation to measurement chamber 84, so long as pump assembly 80 provided for circulation and renewal of air within chamber 84.

[0039] Pump assembly 80 is further comprised of one or more pumps for pumping air into and out of measurement chamber 84. In a preferred embodiment, pump assembly 80 further comprises inlet 89, inlet pump 90, exhaust 91 and

exhaust pump 92. Inlet pump 90 pumps ambient air from inlet 89 through inlet tube 86 into measurement chamber 84, and exhaust pump 92 pumps contaminated air out of measurement chamber 84 through exhaust tube 88 and out exhaust 91.

[0040] Inlet pump 90 and exhaust pump 92 are preferably turbine or centrifugal pumps. However, one of ordinary skill in the art would recognize that other types of pumps suitable for pumping gasses could be used in accordance with the present invention, including fan pumps, diaphragm pumps, peristaltic pumps, and piston pumps.

[0041] Preferably, inlet pump 90 and exhaust pump 92 are placed at the ends of inlet tube 86 and exhaust tube 88 distal from measurement chamber 84, respectively. This placement allows for maximum attenuation of noise generated by inlet pump 90 and exhaust pump 92. However, inlet pump 90 and exhaust pump 92 may be placed at any point in the airflow between measurement chamber 84 and atmosphere in accordance with the present invention.

[0042] As one of ordinary skill in the art would understand, pump assembly 80 could also be comprised of a single pump, as opposed to a combination of input and exhaust pumps. While such a pump assembly would result in chamber pressure somewhat different from ambient, this may well be acceptable in some plethysmographic measurement systems. One of ordinary skill in the art would further recognize that inlet pump 90 and exhaust pump 92 do not have to be placed within a single pump assembly. For example, inlet pump 90 and exhaust pump 92 could be mounted separately within air circulation component chamber 82. Further, one or both of inlet pump 90 and exhaust pump 92 could be mounted outside of air circulation component chamber 82.

[0043] It is also preferable that inlet 89 and exhaust 91 be kept separate from one another. Such a placement of inlet 89 and exhaust 91 ensures that contaminated air pumped out of measurement chamber 84 is exhausted away from inlet 89, in order to prevent contamination of incoming air by excess CO₂ and water vapor being discharged from exhaust 91.

[0044] The physical properties of inlet tube 86 and exhaust tube 88 are important to maintain the acoustic properties of measurement chamber 84, such that accurate measurement of chamber volume can be attained in spite of the coupling of measurement chamber 84 to the external environment. More particularly, by coupling measurement chamber 84 to the environment, acoustic noise could pass through inlet tube 86 and exhaust tube 88 into measurement chamber 84, thereby affecting the accuracy of the body composition measurement. Further, acoustic energy at the frequency of perturbation could also leak outside measurement chamber 84, again affecting the accuracy of measurement.

[0045] However, the air within inlet tube 86 and exhaust tube 88 possesses inertia, which acts to resist movement of air within the tubes in response to pressure fluctuations (such as acoustic noise from outside measurement chamber 84, or the periodic perturbations generated during plethysmographic measurement). This property can be maximized through selection of the length of inlet tube 86 and exhaust tube 88.

[0046] As a first approximation, measurement chamber 84 and inlet tube 86 (or exhaust tube 88) can be modeled in a combined manner as a Helmholtz resonator. The Helmholtz

resonator realized by the combination of measurement chamber **84** and inlet tube **86**/exhaust tube **88** acts as a low-pass filter, attenuating acoustic noise above the resonant frequency of the system (which is inversely proportional to the square root of the length of the tube). Thus, the length of inlet tube **86** and exhaust tube **88** can be selected such that the acoustic low-pass filter properties of the chamber/tube system attenuate frequencies at or above the perturbation frequency. In a preferred embodiment of the invention, the lengths of the inlet tubes and exhaust tubes were selected such that the resonant frequency of the chamber/tube system was an order of magnitude below the perturbation frequency.

[0047] As a second approximation, the acoustic properties of inlet tube **86** and exhaust tube **88** can be looked at independently from measurement chamber **84**. In so doing, the length of the tube would preferably be set at one-quarter the wavelength corresponding to the perturbation frequency in order to minimize transmission of pressure fluctuations through inlet tube **86** and exhaust tube **88** at the perturbation frequency. While adopting this model has been found to yield some benefit, in practice it has been found that simply ensuring that inlet tube **86** and exhaust tube **88** are of sufficient length to attenuate periodic signals at or above the frequency of perturbation (typically, between 3 Hz and 20 Hz, depending on the type of plethysmographic measurement system used) produces satisfactory results.

[0048] In a preferred embodiment, air circulation component chamber **82** further includes heater element **98**, temperature monitoring circuitry **100**, and controlled temperature inlet **102**. In this embodiment, temperature monitoring circuitry **100** monitors the temperature of controlled temperature inlet **102**, and varies the operation of heater element **98** to maintain a constant temperature within controlled temperature inlet **102**. Controlled temperature inlet **102** acts as the source of air for inlet pump **90**; thus, air is pumped from temperature controlled inlet **102** through inlet tube **86** into measurement chamber **84** by means of inlet pump **90**. By providing for a controlled temperature environment within measurement chamber **84**, the potential effects of temperature fluctuation in measurement chamber **84** due to body heat generated by the test subject are minimized.

[0049] Alternatively, heater element **98** can be used to heat the air within inlet tube **86** via conduction. In this embodiment, inlet pump **90** draws air through inlet **89** from the environment outside air circulation component chamber **82**. Temperature monitoring circuitry **100** monitors the temperature of air within inlet tube **86**, and varies the operation of heater element **98** to maintain a constant temperature of incoming air within inlet tube **86**.

[0050] As another alternative, heater element **98** could be coupled to inlet pump **90**, and used to directly heat the air within inlet tube **86**.

[0051] It has also been found in practice that the flow rate of the air circulation system of the present invention can have an effect on the calibration of the plethysmographic measurement system. Systems and methods for calibrating plethysmographic measurement chambers are described in co-pending U.S. patent application Ser. No. 10/036,161, entitled "Calibration Methods and Apparatus for Plethysmographic Measurement Chambers," applied for by Philip Dempster, and filed on Dec. 31, 2001 (attorney internal docket no. LM-003), which application is incorporated herein by reference in its entirety.

[0052] More particularly, as flow rate varies, dynamic resistance to pressure fluctuations also varies (under turbulent conditions). Stability of the system therefore can be improved by controlling flow rate. Thus, in a preferred embodiment, coupled to inlet tube **86** and/or exhaust tube **88** are one or more pressure transducers **104**, which monitor the pressure drop across the inlet and/or exhaust tube. Pressure transducers **104** are further coupled to pump assembly **80** via feedback circuit **106**. Feedback circuit **106**, based on the input from pressure transducers **104**, controls the operation of pump assembly **80** to provide for constant flow rate in the air circulation system. In a preferred embodiment, feedback circuit **106** varies the electrical power to pump assembly **80** to control flow rate.

[0053] One of ordinary skill in the art would recognize that other methods of maintaining flow rate may be used. For example, if pump assembly **80** comprises one or more rotary pumps, constant flow rate may be achieved by controlling the angular velocity of the rotary pump(s). One of ordinary skill in the art would also recognize that pressure drop may be measured across part or all of the tubing system comprised of inlet tube **86** and exhaust tube **88**.

[0054] Further, while the particular flow rate selected must be sufficient to maintain acceptable levels of CO₂ and water vapor in measurement chamber **84**, lower flow rates result in less acoustic noise being generated by the air circulation system. Thus, the particular flow rate selected should balance these two competing considerations. In practice, a wide range of flow rates were found to work successfully.

[0055] Referring now to FIG. 4, a detailed view of a second embodiment of the air circulation components of the present invention is described. Pump assembly **120** includes inlet pump **122** and exhaust pump **124**. Inlet pump **122** is coupled via inlet manifold tube **126** to inlet manifold **128**. Inlet manifold **128** is coupled via parallel inlet chamber tubes **130**, **132**, **134**, and **136** to measurement chamber **138**. Similarly, exhaust pump **124** is coupled via exhaust manifold tube **140** to exhaust manifold **142**. Exhaust manifold **142** is coupled via parallel exhaust chamber tubes **144**, **146**, **148**, and **150** to measurement chamber **138**.

[0056] As with the previously described embodiments, pump assembly **120** both pumps ambient air through inlet manifold tube **126**, inlet manifold **128**, and inlet chamber tubes **130**, **132**, **134**, and **136** into measurement chamber **138**, and pumps air contaminated with triatomic gasses (such as water vapor and CO₂) out of measurement chamber **138** through exhaust chamber tubes **144**, **146**, **148**, and **150**, exhaust manifold **142**, and exhaust manifold tube **140**. By coupling both inlet manifold **128** and exhaust manifold **142** with measurement chamber **138** via multiple, parallel tubes, this embodiment both provides for reduced flow resistance in comparison to full lengths of multiple parallel tubes between the manifolds and measurement chamber **138**, while at the same time providing quieter, laminar flow at the entry of measurement chamber **138** compared to the single inlet and exhaust tube embodiment described in connection with FIG. 3.

[0057] While preferred illustrative embodiments of the invention are described above, it will be apparent to one skilled in the art that various changes and modifications may be made therein without departing from the invention. The

appended claims are intended to cover all such changes and modifications that fall within the true spirit and scope of the invention.

1. A plethysmographic measurement system, comprising:
 - a plethysmographic measurement chamber;
 - plethysmographic measurement components coupled to the measurement chamber; and
 - an air circulation system coupled between the measurement chamber and the environment outside the measurement chamber,
 wherein the air circulation system renews air within the measurement chamber using air from the environment outside the chamber during plethysmographic measurement.
2. The system of claim 1, wherein the measurement components are housed within the measurement chamber.
3. The system of claim 1, further comprising a chamber door coupled to the measurement chamber.
4. The system of claim 1, wherein the measurement components comprise:
 - a volume perturbation element, and
 - means for determining pressure within the chamber.
5. The system of claim 4, wherein the means for determining pressure comprises one or more pressure transducers.
6. The system of claim 4, wherein the volume perturbation element is an oscillating diaphragm.
7. The system of claim 4, wherein the volume perturbation element generates pressure oscillations within the measurement chamber at a first frequency.
8. The system of claim 4, wherein the frequency is between 3 and 20 Hz.
9. The system of claim 1, wherein the air circulation system comprises:
 - a pump assembly;
 - an inlet tube coupled between the measurement chamber and the pump assembly, and
 - and an exhaust tube coupled between the measurement chamber and pump assembly.
10. The system of claim 9, wherein the pump assembly comprises an inlet pump and an exhaust pump.
11. The system of claim 9, wherein the pump assembly comprises one or more rotary pumps.
12. The system of claim 9, wherein the pump assembly comprises one or more turbine pumps.
13. The system of claim 9, wherein the pump assembly comprises one or more centrifugal pumps.
14. The system of claim 9, wherein the pump assembly comprises one or more fan pumps.
15. The system of claim 9, wherein the pump assembly comprises one or more diaphragm pumps.
16. The system of claim 9, wherein the pump assembly comprises one or more piston pumps.
17. The system of claim 9, wherein the pump assembly comprises one or more peristaltic pumps
18. The system of claim 9, further comprising: a plurality of parallel inlet tubes.
19. The system of claim 9, further comprising a plurality of parallel exhaust tubes.

20. The system of claim 10, wherein the inlet pump is placed at the end of the inlet tube distal from the measurement chamber.

21. The system of claim 10, wherein the exhaust pump is placed at the end of the exhaust tube distal from the measurement chamber.

22. The system of claim 1, wherein the air circulation system comprises:

a pump assembly;

an inlet manifold tube coupled between the pump assembly and an inlet manifold,

an inlet chamber tube coupled between the inlet manifold and the measurement chamber,

an exhaust manifold tube coupled between the exhaust manifold and the measurement chamber, and

an exhaust chamber tube coupled between the exhaust manifold and the pump assembly.

The system of claim 22, further comprising: a plurality of parallel tubes coupled between the inlet manifold and the measurement chamber.

23. The system of claim 22, further comprising: a plurality of parallel tubes coupled between the exhaust manifold and the measurement chamber.

24. The system of claim 22, wherein the measurement components comprise:

a volume perturbation element; and

a pressure transducer.

25. The system of claim 25, wherein the volume perturbation element generates volume perturbations at a first perturbation frequency.

26. The system of claim 26, wherein the inlet tube and exhaust tube attenuate noise at the perturbation frequency.

27. The system of claim 26, wherein the length of the inlet tube is one quarter of a wavelength corresponding to the perturbation frequency.

28. The system of claim 26, wherein the length of the exhaust tube is one quarter of a wavelength corresponding to the perturbation frequency.

29. The system of claim 9, further comprising:

a pressure transducer; and

a feedback circuit coupled between the pump assembly and the pressure transducer, wherein the pressure transducer measures a flow rate of the air circulation system, and wherein the feedback circuit maintains a constant flow rate in the air circulation system.

30. The system of claim 29, wherein the pressure transducer is coupled to the inlet tube.

31. The system of claim 29 wherein the pressure transducer is coupled to the exhaust tube.

32. The system of claim 29, wherein the feedback circuit varies the operation of the pump assembly.

33. The system of claim 33, wherein the pump assembly comprises one or more rotary pumps, and wherein the feedback circuit varies the angular velocity of the one or more rotary pumps.

34. The system of claim 1, further comprising:

a controlled temperature environment, wherein the air circulation system pumps air from the controlled temperature environment into the chamber.

35. The system of claim 35, wherein the air circulation system comprises:

a pump assembly coupled to the controlled temperature environment;

an inlet tube coupled between the measurement chamber and the pump assembly, and

an exhaust tube coupled between the measurement chamber and pump assembly.

36. The system of claim 36, wherein the controlled temperature environment comprises:

a heater element; and

temperature monitoring circuitry coupled to the heater element.

37. The system of claim 37, wherein the temperature monitoring circuitry maintains a constant temperature within the controlled temperature environment.

38. The system of claim 38, wherein the temperature monitoring circuit controls the operation of the heater element.

39. The system of claim 1, further comprising:

a pump assembly coupled to the controlled temperature environment;

an inlet tube coupled between the measurement chamber and the pump assembly, and

an exhaust tube coupled between the measurement chamber and the pump assembly;

a heater element; and

temperature monitoring circuitry coupled to the heater element.

40. The system of claim 40, wherein the temperature monitoring circuitry maintains a constant air temperature within the inlet tube.

41. The system of claim 41, wherein the temperature monitoring circuit controls the operation of the heater element.

42. A method of conducting plethysmographic measurement of a test subject, comprising:

placing the subject to be measured in a plethysmographic measurement chamber,

sealing said chamber;

conducting plethysmographic measurement of the subject, and

renewing air within the chamber using air from the environment outside the chamber.

43. The method of claim 43, wherein conducting plethysmographic measurement comprises:

generating pressure oscillators within the chamber;

measuring the amplitude of the pressure oscillators;

calculating a volume of air within the chamber based on the measured pressure oscillations; and

determining a body composition of the test subject based on the calculated volume of air within the chamber.

44. the method of claim 44, wherein generating pressure oscillations comprises:

oscillating a diaphragm at a fixed frequency.

45. The method of claim 43, wherein renewing air through the chamber comprises:

pumping air through an inlet tube into the chamber; and

pumping air through an exhaust tube out of the measurement chamber.

46. The method of claim 46, wherein pumping air through an inlet tube comprises:

establishing a controlled temperature environment; and

pumping air from the controlled temperature environment through the inlet tube.

47. The method of claim 47, wherein establishing a controlled temperature environment comprises:

measuring the temperature of an enclosed environment;

comparing the measured temperature to a desired control temperature;

varying the operation of a heater element in response to the comparison of the measured temperature to the desired temperature.

48. The method of claim 46 further comprising: heating the air with the inlet tube to a controlled temperature.

49. The method of claim 49, wherein heating the air with the inlet tube to a controlled temperature comprises:

measuring the temperature of air within the inlet tube;

comparing the measured temperature to a desired control temperature; and

varying the operation of a heater element in response to the comparison of the measured temperature to the desired temperature.

50. The method of claim 43, further comprising:

maintaining a constant flow rate of air being circulated through the chamber.

51. The method of claim 51, wherein maintaining a constant flow rate comprises:

measuring a flow rate;

comparing the measured flow rate to a desired flow rate, and

varying the operation of an air pump in response to comparing the measured flow rate to the control flow rate.

* * * * *

专利名称(译)	用于体积描记测量室的空气循环设备和方法		
公开(公告)号	US20040193074A1	公开(公告)日	2004-09-30
申请号	US10/402225	申请日	2003-03-26
[标]申请(专利权)人(译)	DEMPSTER用Philip的T HOMER人Michael V MARK LOWE		
申请(专利权)人(译)	DEMPSTER PHILIP T. HOMER MICHAEL V. MARK LOWE		
当前申请(专利权)人(译)	DEMPSTER PHILIP T. HOMER MICHAEL V. MARK LOWE		
[标]发明人	DEMPSTER PHILIP T HOMER MICHAEL V LOWE MARK		
发明人	DEMPSTER, PHILIP T. HOMER, MICHAEL V. LOWE, MARK		
IPC分类号	A61B5/00 A61B5/08 A61B5/103 G01F17/00		
CPC分类号	A61B5/0806 G01F17/00 A61B5/1073		
其他公开文献	US7022087		
外部链接	Espacenet USPTO		

摘要(译)

提供了与体积描记测量室内的空气循环有关的装置和方法。由一个或多个泵组成的空气循环系统使用一个或多个入口和排出管连接到体积描记测量室。空气循环系统使用环境空气或来自受控温度环境的空气来更新测量室内的空气。

