



(19) **United States**

(12) **Patent Application Publication** (10) **Pub. No.: US 2002/0111543 A1**

Penner et al. (43) **Pub. Date: Aug. 15, 2002**

(54) **SYSTEMS AND METHODS FOR
DEPLOYING A BIOSENSOR IN
CONJUNCTION WITH A PROSTHESIS**

(52) **U.S. Cl.** **600/309; 606/139**

(76) **Inventors: Avi Penner, Tel Aviv (IL); Lone
Wolinsky, Ramat Gan (IL)**

(57) **ABSTRACT**

Correspondence Address:

**LYON & LYON LLP
633 WEST FIFTH STREET
SUITE 4700
LOS ANGELES, CA 90071 (US)**

(21) **Appl. No.: 10/122,015**

(22) **Filed: Apr. 12, 2002**

Related U.S. Application Data

(63) **Continuation of application No. 09/522,370, filed on
Mar. 10, 2000.**

Publication Classification

(51) **Int. Cl.⁷ A61B 5/00**

A biosensor for monitoring pressure or other physical parameters at an aneurysm site is mountable to a tubular prosthesis that is expandable between contracted and enlarged conditions. A loop, having the biosensor attached thereto, is securable around the prosthesis. An apparatus is used to deliver the loop to an aneurysm site that includes a catheter having a connector on its distal end for detachably securing the loop thereto. The prosthesis is advanced in a contracted state to the aneurysm, and the apparatus, with the loop connected thereto, is advanced to the aneurysm site. The loop and the prosthesis are positioned coaxially with respect to one another, and the prosthesis is expanded towards its enlarged condition, thereby engaging the loop around the prosthesis and engaging the prosthesis with a wall of the blood vessel at the treatment site.

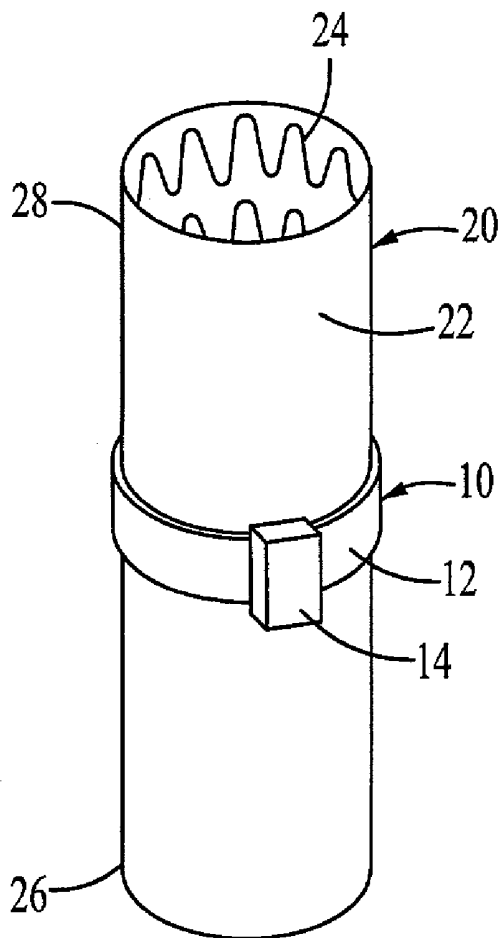

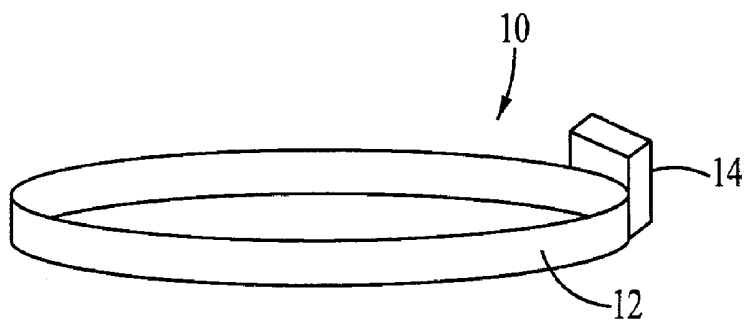

FIG. 1

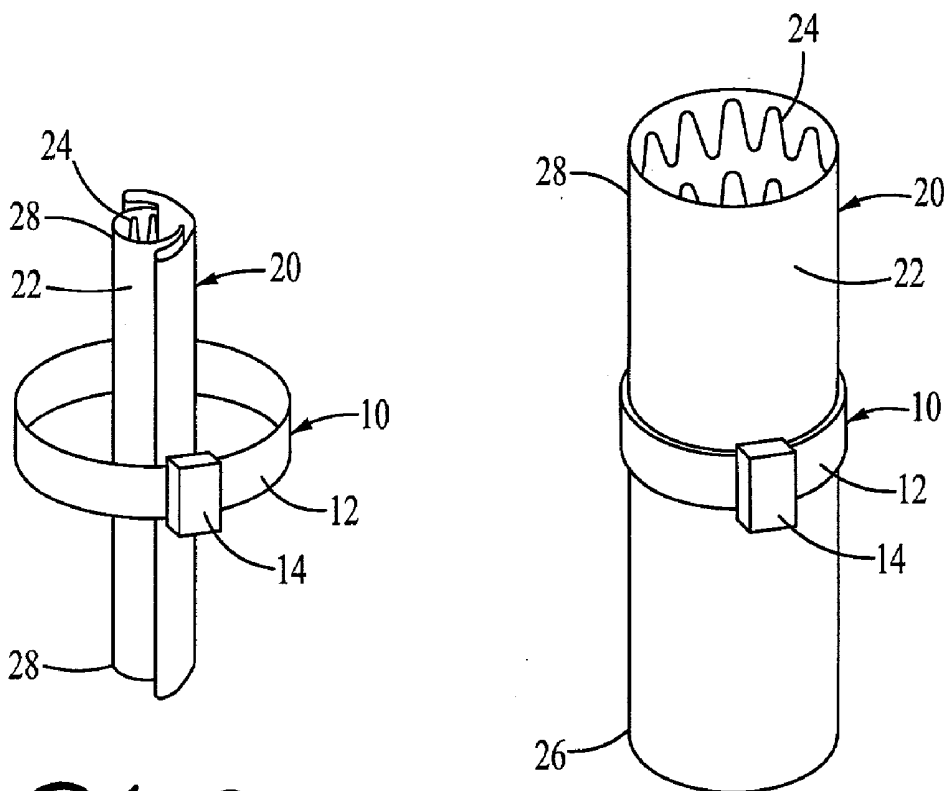

FIG. 2A

FIG. 2B

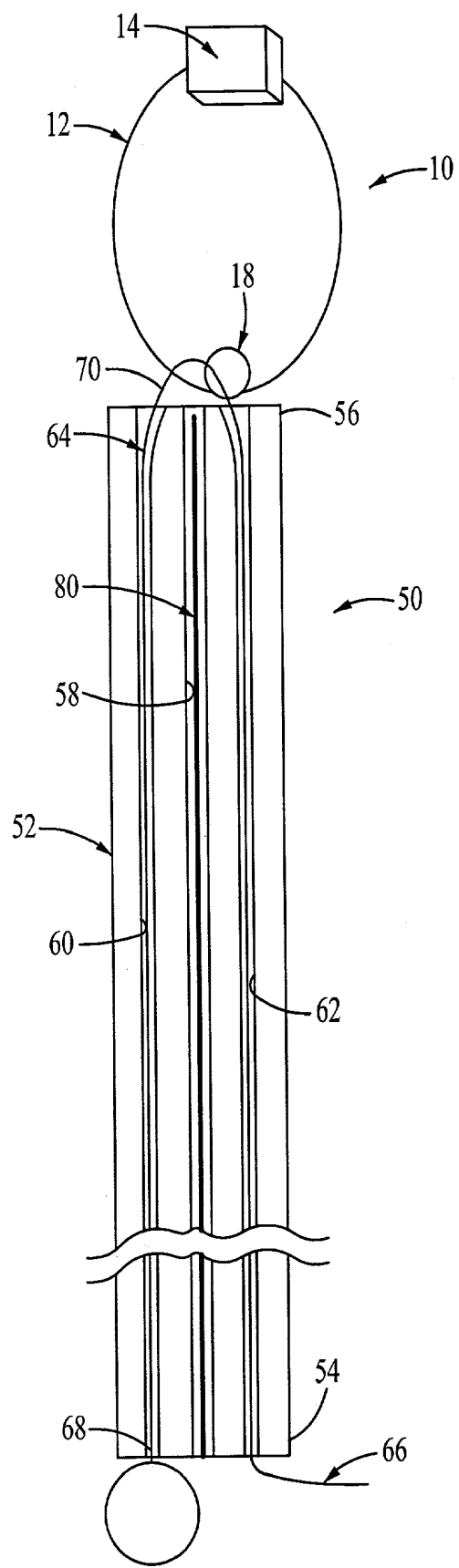

FIG. 3

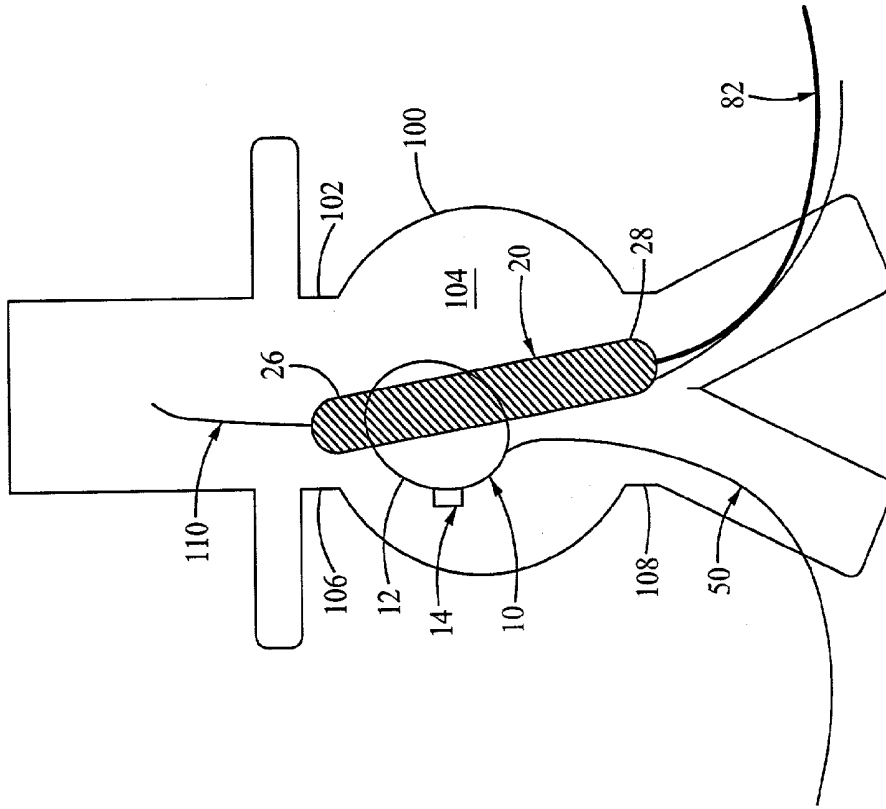

FIG. 4A

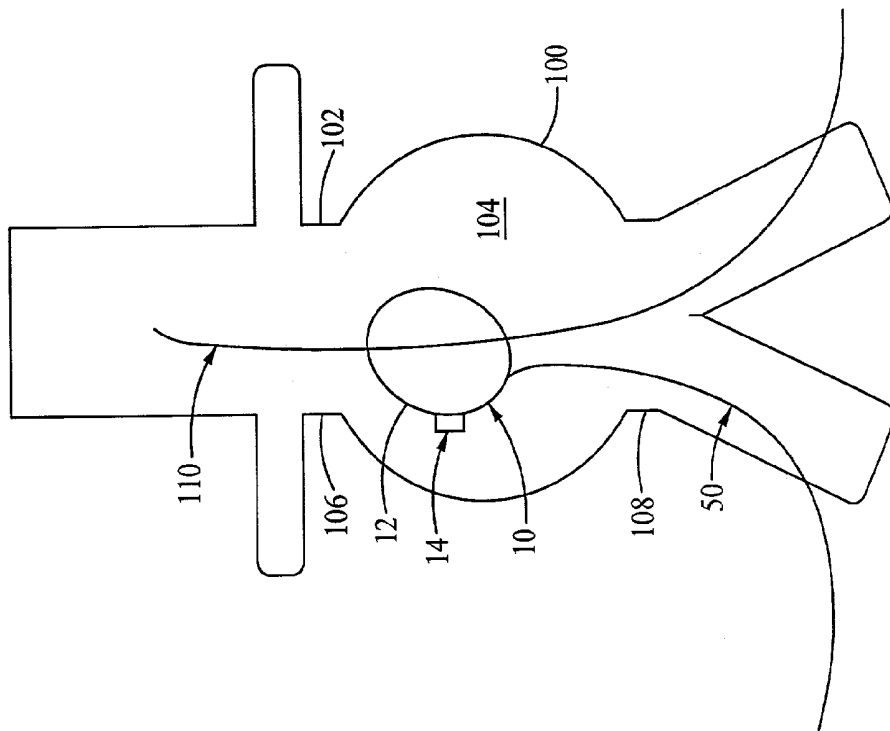

FIG. 4B

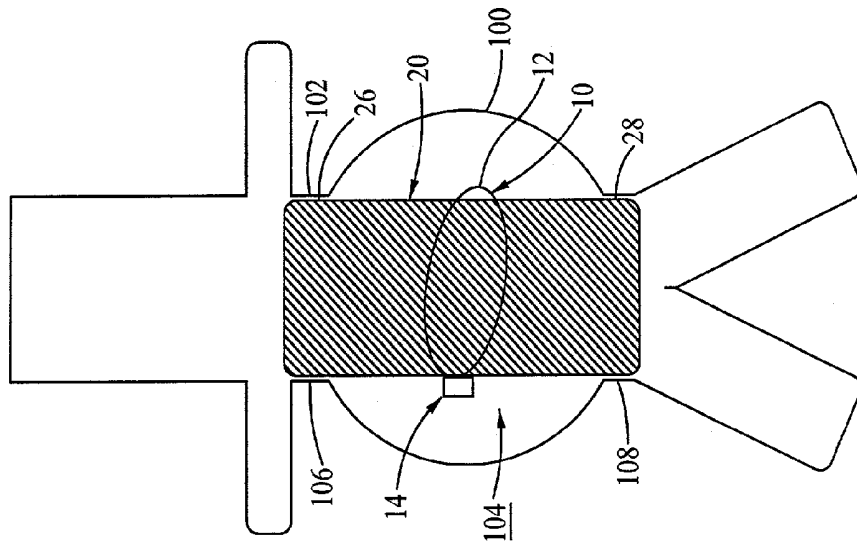

FIG. 4D

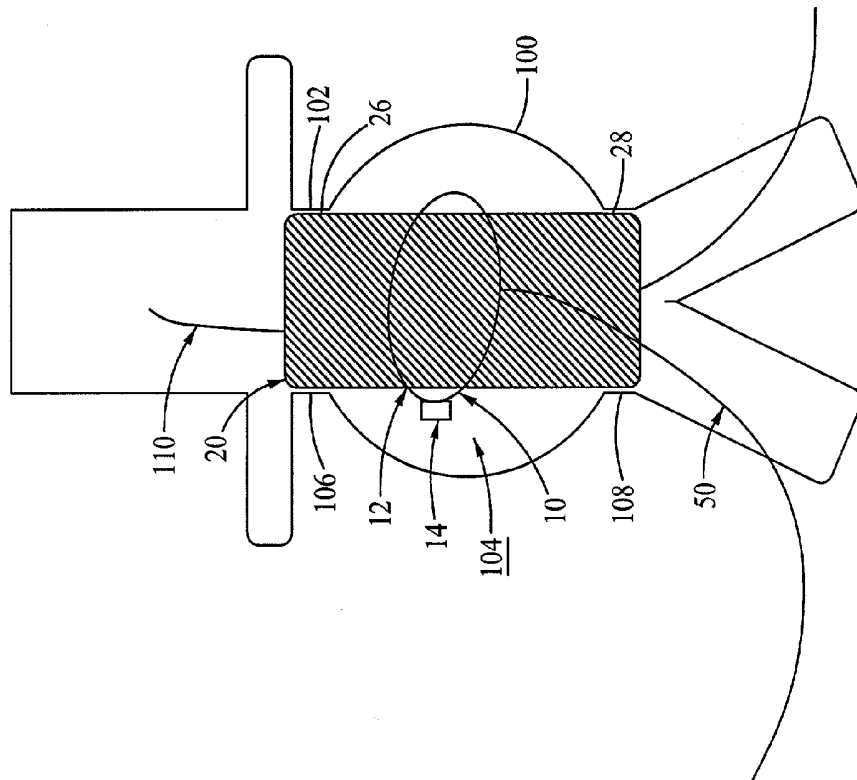

FIG. 4C

SYSTEMS AND METHODS FOR DEPLOYING A BIOSENSOR IN CONJUNCTION WITH A PROSTHESIS

[0001] The present application is a continuation of U.S. application Ser. No. 09/522,370, filed on Mar. 10, 2000, the entirety of which is incorporated herein by reference.

FIELD OF THE INVENTION

[0002] The present invention relates generally to implantable medical devices for monitoring internal physiological conditions of a patient, and, more particularly, to a biosensor that is attachable to a prosthesis for remotely monitoring physiological conditions of a patient, such as pressure within an aneurysm cavity across which a prosthesis is implanted.

BACKGROUND

[0003] An aneurysm is a weakening of a wall of a blood vessel that generally results in a ballooning of the wall, and, if left untreated, may result in a rupture that may seriously threaten the life of a patient. The weakening of the wall may be due to injury, infection, or other conditions, such as a congenital defect in the arterial connective tissue. Common forms of such an aneurysm include an abdominal aortic aneurysm ("AAA"), an iliac aneurysm, a bifurcated aneurysm of the abdominal aorta and one or both of the iliac arteries, and a thoracic aortic aneurysm.

[0004] To treat a patient suffering from an aneurysm, a tubular prosthetic graft may be implanted across the aneurysm using an open surgical technique to substantially isolate the weakened region of the vessel from adjacent healthy regions. For example, the vessel wall may be cut longitudinally along the vessel wall, the graft inserted and anastomosed coaxially within the vessel as an internal replacement for the diseased segment, and then the longitudinal cut may be sutured closed. Alternatively, opposite ends of a prosthetic graft may be sutured to a vessel on either side of the weakened region to form a bypass conduit around the diseased segment. Such surgical approaches, however, may involve extensive recovery times, may be complicated because of the difficulties in suturing the graft to the vessel, and/or may be unsuitable for many at-risk patients because of the high mortality and morbidity rates associated with a surgical intervention of this magnitude.

[0005] As an alternative to open surgery, endoluminal stent graft implantation has been suggested. An endoluminal stent graft generally includes a vascular graft and a support structure, such as a self-expanding or balloon-expandable stent, that may engage each end of the graft or may extend along all or a portion of a length of the graft. The stent graft may be introduced percutaneously into the patient's vasculature in a reduced profile, for example, on or in a delivery catheter. The stent graft may be advanced to a treatment site, such as a damaged segment of the abdominal aorta, and placed across the treatment site. The support structure may then be radially expanded, anchoring the graft to the healthy regions of the vessel adjacent the damaged segment, and substantially sealing the aneurysm from the rest of the circulatory system. As a result, pressure within the isolated aneurysmal sac may be reduced, thereby reducing stress or "endotension" on the weakened wall of the vessel. Endotension is a physical parameter that may indicate the likelihood of an aneurysm rupturing, and is generally defined in

terms of the internal pressure within the aneurysm, the aneurysm diameter and vessel wall thickness.

[0006] One potential complication that may occur after a stent graft is implanted is the formation of an endoleak. Endoleaks may be divided into four categories: leakage due to improper sealing of the graft against the vessel wall (Type I), blood flow into the aneurysmal sac through bypass arteries (Type II), leakage due to mechanical failure of the graft system (Type III), and leakage through the graft due to the porosity of the graft material (Type IV).

[0007] If fluid leaks into the aneurysmal sac, it may increase the pressure or endotension within the aneurysm, possibly resulting in an aneurysmal rupture. To substantially reduce the risk of this occurring, early detection of endoleaks or endotension may be important. With early detection, the pressure within the aneurysmal sac may be reduced by subsequent endovascular treatment (for example, further expansion of the stent graft support structure, or additional stent graft implantation to improve sealing), or, if necessary, surgical intervention.

[0008] Currently, contrast-enhanced computerized tomography (CT) is often used to detect endoleaks, which relies on x-ray imaging of an abdominal region after injection of a contrast media. If an endoleak is present, the aneurysmal sac may fill with contrast media and the endoleak may then be identified by the CT scan. Although CT scans are considered a reliable method for detecting endoleaks, they require an experienced operator and an expensive apparatus, placing significant financial constraints on its frequency of use. In addition, a CT scan procedure exposes the patient to x-ray radiation, and thus may only be recommended every 3 to 6 months following stent graft implantation. Finally, because CT scans only detect actual leakage and not pressure within the aneurysm, they may not detect small leaks that may cause slow, but potentially dangerous, pressurization within the aneurysm.

[0009] As an alternative to CT scans, ultrasound imaging may be used to detect endoleaks. Ultrasound imaging uses a simpler apparatus, resulting in a potential cost savings over CT scanning, and does not involve the use of ionizing radiation and its associated risks. The quality of ultrasound imaging, however, may be more operator dependent, and therefore may be less reliable than CT scans.

[0010] Accordingly, it is believed that a system and method for monitoring internal pressure within an aneurysmal sac may be considered useful.

SUMMARY OF THE INVENTION

[0011] The present invention is directed to apparatus and methods for implanting a biosensor, preferably in conjunction with an endoprosthesis, within an abdominal aortic aneurysm or other enlarged or weakened treatment site within a body lumen of a patient.

[0012] In accordance with a first aspect of the invention, an apparatus for monitoring a physical parameter at a treatment site within a body lumen is provided. The apparatus includes a tubular prosthesis expandable between a contracted condition for facilitating introduction into the body lumen, and an enlarged condition for contacting a wall of the body lumen at the treatment site. A substantially enclosed loop having a size for substantially securing the

loop around the prosthesis in its enlarged condition is provided with a biosensor attached to the loop.

[0013] In one preferred embodiment, the loop may be a ring or sleeve formed from a substantially elastic material, the ring or sleeve having a relaxed state having a cross-section smaller than the prosthesis in its enlarged condition. In an alternate preferred embodiment, the loop may be a substantially inelastic, flexible thread having a cross-section similar to the prosthesis in its enlarged condition.

[0014] In accordance with another aspect of the invention, an apparatus is provided for delivering the biosensor device to a treatment site within a body lumen. The apparatus includes an elongate member having a proximal end and a distal end adapted for introduction into the body lumen, and a connector located on the distal end of the elongate member for detachably securing the loop to the distal end of the elongate member. Preferably, an actuator is provided on a proximal end of the elongate member for detaching the loop from the connector. In preferred embodiments, the apparatus may also include a sheath slidable over the elongate member or other constraint for constraining the loop to facilitate its introduction into the body lumen.

[0015] By way of example, in one preferred embodiment, the connector is a wire having a first end extending from the proximal end of the elongate member, and a second end extending to the distal end of the elongate member. The wire may be intertwined with the loop to thereby substantially secure the loop to the distal end of the elongate member. The actuator preferably is a handle on the first end of the wire for pulling the second end of the wire from the distal end towards the proximal end, thereby releasing the loop therefrom. The loop may include a ring for receiving the wire therethrough.

[0016] In accordance with still another aspect of the invention, a delivery device is provided for directing the prosthesis to the treatment site in its contracted condition. The delivery device preferably has a cross-section substantially smaller than a cross-section of the loop, thereby facilitating positioning the loop coaxially with respect to the prosthesis before the prosthesis is deployed from the delivery device.

[0017] In accordance with yet another aspect of the invention, a method is provided for implanting a biosensor at a treatment site within a body lumen. In a preferred implementation, a tubular prosthesis is advanced in a contracted state within the body lumen to the treatment site, for example, mounted to a delivery device. A loop is also advanced to the treatment site, the loop including a biosensor attached thereto. Preferably, the loop is detachably connected to a delivery apparatus that is used to advance the loop to the treatment site. The loop may be deployed from a compressed state on the delivery apparatus once advanced to the treatment site, and manipulated to assume an open configuration across the treatment site.

[0018] In one preferred embodiment, the loop may be expanded across the treatment site before the prosthesis is advanced to the treatment site, and the prosthesis may be advanced through the loop upon advancement of the prosthesis to the treatment site. Alternatively, the loop may be advanced coaxially over the delivery device to the treatment site.

[0019] Preferably, the loop and the prosthesis may be positioned coaxially with respect to one another at the treatment site. The prosthesis may then be expanded towards an enlarged condition, thereby substantially engaging the loop around the prosthesis and substantially engaging the prosthesis to a wall of the blood vessel at the treatment site. Once the prosthesis is expanded, the loop may be released from the delivery apparatus, and the apparatus withdrawn from the patient. As a result, the biosensor is disposed within an aneurysmal sac at least partially defined by the aneurysm. The biosensor may then be used to remotely monitor the aneurysmal sac to detect pressure, leaks or other desired physical conditions therein.

[0020] Other objects and features of the present invention will become apparent from consideration of the following description taken in conjunction with the accompanying drawings.

BRIEF DESCRIPTION OF THE DRAWINGS

[0021] FIG. 1 is a perspective view of a preferred embodiment of a biosensor attached to a flexible band.

[0022] FIGS. 2A and 2B are perspective views of a stent graft in a contracted and an expanded condition, respectively, with the biosensor of FIG. 1 disposed therearound.

[0023] FIG. 3 is a side view of a preferred embodiment of an apparatus for delivering a biosensor device detachably secured to the apparatus by a wire connector.

[0024] FIGS. 4A-4D are cross-sectional views of an abdominal aortic aneurysm, showing the implantation of a stent graft across the aneurysm with a biosensor mounted thereon that is disposed within the aneurysmal sac.

DETAILED DESCRIPTION OF THE PREFERRED EMBODIMENTS

[0025] Turning now to the drawings, FIG. 1 shows a first preferred embodiment of a biosensor device 10 that includes a loop or lasso 12, preferably a substantially enclosed band of material, to which a biosensor 14 is attached. The biosensor 14 may be attached to the loop 12 by any known method, such as with sutures, adhesives, sonic welding, and the like. The biosensor 14 may be used to remotely measure one or more physical parameters within a patient's body.

[0026] For example, the biosensor 14 may be a pressure sensor, a temperature sensor, a pH sensor, a blood sugar sensor, a blood oxygen sensor, a motion sensor, a flow sensor, a velocity sensor, an acceleration sensor, a force sensor, a strain sensor, an acoustics sensor, a moisture sensor, an osmolarity sensor, a light sensor, a turbidity sensor, a radiation sensor, an electromagnetic field sensor, a chemical sensor, an ionic sensor, and an enzymatic sensor.

[0027] In preferred embodiments, the biosensor 14 employs wireless telemetry to deliver information from the implantation site to an instrument external to the body. Further, the biosensor may or may not require a battery. For example, one preferred biosensor 14 is constructed in accordance with the teachings of U.S. patent application Ser. No. 09/303,644, which is fully incorporated by reference for all that it teaches and discloses. As taught therein, an acoustic telemetry biosensor includes means for converting acoustic energy received from an externally originated interrogation

signal into a current supply for powering one or more sensors embedded in the biosensor for measuring various biological parameters at the implantation site. The biosensor **14** further preferably includes means for modulating the interrogation signal to transmit the measured information external to the body.

[0028] In another preferred embodiment, the biosensor **14** is constructed in accordance with the teachings of U.S. Pat. No. 5,704,352, which is also fully incorporated by reference for all that it teaches and discloses. Other biosensor constructions are also possible and will be known to those skilled in the art.

[0029] Turning to **FIGS. 1, 2A, and 2B**, the loop **12** has a predetermined cross-section for substantially engaging a prosthesis **20** in its enlarged profile (**FIG. 2B**). The prosthesis **20** is preferably a stent graft including a tubular prosthetic graft **22** supported by a support structure **24**. The graft **22** may be provided from a substantially non-porous bio-compatible material, such as Dacron or ePTFE, that is formed into a tubular shape. The material is substantially flexible, thereby allowing the graft **22** to be rolled or folded into a reduced profile, accommodating delivery through tortuous anatomy, and/or facilitating implantation within curved blood vessels.

[0030] The support structure **24** is preferably a tubular stent that extends along an inside surface of the graft **22** for substantially the entire length of the graft **22**. The support structure **24** may be attached to the graft **22** in a variety of ways, such as by sutures, wires, sonic welding, adhesives, and the like, as is well known in the art.

[0031] In an alternative embodiment, the support structure **24** may be attached to an outer surface of the graft (not shown), or may be woven into the graft material (also not shown). In a further alternative, a pair of stents (not shown) may be provided that may be attached to respective end regions of the graft **22**, with an intermediate region of the graft **22** being unsupported.

[0032] The support structure **24** is radially expandable between a contracted condition (**FIG. 2A**) for facilitating introduction into a patient's vasculature, and an enlarged condition (**FIG. 2B**) for substantially engaging the wall of a blood vessel. In one embodiment, the support structure **24** may be a self-expanding stent, i.e., that is biased towards its enlarged condition but may be compressed and/or constrained in its contracted condition during delivery. Alternatively, the support structure **24** may be a plastically-deformable stent, i.e., that remains in its contracted condition until it is forcibly expanded to assume its enlarged condition, for example, using a balloon.

[0033] In one preferred embodiment, the loop **12** is formed from a substantially elastic material, such as silicon or polyurethane. The loop **12** preferably has a relaxed state having a cross-section substantially smaller than the prosthesis **20** in its enlarged condition, for example, 25-50% smaller. Preferably, the elastic material has an elasticity such that the loop **12** applies a radially inward pressure against the prosthesis **20** that is sufficiently strong to substantially secure the loop **12** to the prosthesis **20** in its enlarged condition without deforming or damaging the prosthesis **20**. For example, the loop **12** may impose a pressure that is less than the anticipated internal pressure experienced within a

body lumen, whereby the internal pressure may counteract the inward pressure imposed by the loop **12**. Preferably, the loop **12** imposes an inward pressure of between about 5-60 mm Hg against the prosthesis in its enlarged condition.

[0034] In alternate preferred embodiments (not shown), the loop **12** may be formed from a substantially inelastic, flexible thread or band of material having a cross-section similar to the prosthesis **20** in its enlarged condition. Preferably, the loop **12** has a cross-section about 5-30 percent larger than a cross-section of the prosthesis **20** in its enlarged condition. Alternatively, the loop **12** may be semi-rigid and may have a "C" shape (not shown) allowing it to be secured around the prosthesis **20** when the prosthesis **20** is expanded. In a still further alternative embodiment, the loop **12** may include an inelastic portion and an elastic portion (not shown).

[0035] The loop **12** may be substantially flexible and limp, or alternatively, may be biased to assume a substantially circular, open configuration. For example, the loop **12** may be formed from a shape memory or superelastic alloy, such as a nickel-titanium ("Nitinol™") alloy. Thus, the loop **12** may be compressed, wrapped, or coiled into a compressed state to facilitate its introduction into a patient's vasculature, but may automatically expand to its open configuration upon release at a treatment site where the device **10** is to be implanted.

[0036] Turning to **FIG. 3**, an apparatus **50** is shown for delivering the biosensor device **10** within a body lumen of a patient. The apparatus **50** includes a flexible catheter **52** or other elongate member, having a proximal end **54** and a distal end **56** having a size and shape for facilitating insertion into a patient's vasculature. The catheter **52** may have a guidewire lumen **58** to facilitate advancement of the catheter **52** over a guidewire **80**, as is known in the art.

[0037] The catheter **52** preferably includes first and second lumens **60, 62** that extend between the proximal and distal ends **54, 56**. A wire **64**, for example, made of nylon or other flexible, low friction material, may be slidably inserted into the lumens **60, 62** such that first and second ends **66, 68** of the wire **64** extend from the proximal end **54** and an intermediate portion **70** forms a looped connector that extends from the distal end **56**. The first end **66** is provided loose, while the second end **68** preferably includes a handle **69**.

[0038] The loop **12** may be received in the intermediate portion **70** for substantially securing the biosensor device **10** to the distal end **56** of the catheter **52**. For example, during assembly, the first end **66** of the wire **64** may be inserted distally into the first lumen **60** from the proximal end **54** of the catheter **52** until it extends from the distal end **56** (not shown). The wire **64** may then be intertwined through the loop **12**, preferably through a ring **18** attached to the loop **12**, and inserted proximally into the second lumen **62**, possibly until the first end **66** extends from the proximal end **56** of the catheter **52**. Alternatively, the wire **64** may be intertwined through a hole in the biosensor device **10**.

[0039] When it is desired to disconnect the biosensor device **10** from the catheter **52**, the handle **69** may be pulled until the first end **66** of the wire **64** is pulled from the second lumen **62** and enters the first lumen **60**, thereby releasing the loop **12** from the wire **64**. Thus, the wire **64** provides a

connector for securing the biosensor device **10** to the catheter **52**, and the handle **69** provides an actuator for releasing the biosensor device **10** that may be activated from the proximal end **54** of the catheter **52**. If additional protection of the biosensor device **10** is desired, an overlying sheath (not shown) may be provided that is slidable over the catheter **52** from the proximal end **54** to the distal end **56**. A locking mechanism may be included to prevent the unintentional detachment of the biosensor device **10**.

[0040] The biosensor device **10** may be received in a lumen of the sheath, for example, simply by advancing the sheath distally over the biosensor device **10**, or by compressing the loop **12** and inserting the compressed biosensor device **10** into the sheath.

[0041] In an alternative embodiment, the first and second lumens **60**, **62** may terminate proximate to the distal end **56**, thereby securing the biosensor device **10** to a side region of the catheter **52** (not shown). If desired, the loop **12** may then be wound around the catheter **52** and constrained thereon, for example, by an overlying sheath (not shown).

[0042] In a further alternate embodiment, a different connector may be provided on the distal end **56** of the catheter **52**, such as a pair of opposing mandibles (not shown) having a slot therebetween for engaging the loop **12**, that may be activated by an actuator (not shown) on the proximal end **54** of the catheter **52**.

[0043] Turning to FIGS. 4A-4D, a method for implanting the biosensor device **10** in conjunction with a prosthesis **20** is shown. In a preferred method, the prosthesis **20** is implanted across an aneurysm **100** in an abdominal aorta **102** of a patient with the biosensor device **10** secured around the prosthesis **20** such that the biosensor **14** is disposed within an aneurysmal sac **104** of the aneurysm **100**. Alternatively, the method may be used to treat other enlarged or weakened regions within a blood vessel, for example, an aneurysm within the iliac arteries, the thoracic aorta, the cranial artery, and the like.

[0044] As shown in FIG. 4A, a guidewire **110** may be placed across the aneurysm site **100** in a conventional manner, for example, from a peripheral artery, such as the femoral artery (not shown). The biosensor device **10**, secured to the distal end **56** of the catheter **52**, may be advanced endolumenally to the aneurysm site **100**, for example, from the contralateral femoral artery (not shown). Alternatively, the biosensor device **10** may be advanced to the aneurysm site **100** from the same peripheral artery as the guidewire **110** (not shown).

[0045] If constrained to the catheter **52**, the loop **12** may be released from the constraint (e.g., by withdrawing an overlying sheath) such that it extends substantially transversely across the aneurysm site **100**. If the loop **12** is biased to its open configuration, the loop **12** may automatically unfurl or expand after being released to extend across the aneurysm site **100**. Otherwise, the loop **12** may be manipulated to properly orient it, for example, under fluoroscopic guidance, which may be facilitated by radiopaque markers (not shown) provided at predetermined locations on the loop **12**.

[0046] Preferably, the loop **12** is manipulated such that it extends coaxially around the guidewire **100**. If the biosensor device **10** is introduced through the ipsilateral artery, the

loop **12** may be aligned around the guidewire **110** before the biosensor device **10** advanced to the aneurysm site **100**.

[0047] As shown in FIG. 4B, the prosthesis **20**, in its contracted condition, may be advanced endolumenally to the aneurysm site **100**. For example, the prosthesis **20** may be secured to a delivery device **82**, which may include a catheter, a sheath, and/or other conventional device, that may be advanced over the guidewire **100**. The prosthesis **20** may be positioned with respect to the loop **12**, for example, by advancing the delivery device **82** through the loop **12**, and positioning the prosthesis **20** with respect to the aneurysm **100**.

[0048] This may also be performed under fluoroscopic guidance, with radiopaque markers provided on the delivery device **82** and/or on the prosthesis **20**. Preferably, the prosthesis **20** is positioned such that ends **26**, **28** of the prosthesis **20** are aligned with the healthy regions **106**, **108** of the vessel adjacent to the aneurysm **100**. The loop **12** may then be adjusted to position it with respect to the prosthesis **20**, i.e., to position the biosensor **14** at a desired location along the length and/or around the outer surface of the prosthesis **20**.

[0049] As shown in FIG. 4C, the prosthesis **20** may then be expanded to its enlarged condition, thereby securing the ends **26**, **28** to the healthy regions **106**, **108** of the vessel, and substantially securing the loop **12** around the prosthesis **20**. For example, if the prosthesis **20** includes a self-expanding support structure, the prosthesis **20** may automatically expand upon being released from the delivery device **82**. Alternatively, an expandable member, such as a balloon (not shown) on the delivery device **82**, may be used to forcibly expand the prosthesis **20**, as is known in the art. A final inflation of the balloon may be used to provide a good seal between the distal ends **26**, **28** of the prosthesis **20** and the healthy regions **106**, **108** of the vessel.

[0050] Finally, as shown in FIG. 4D, the biosensor device **10** may be released from the catheter **52**, and the catheter **52** and delivery apparatus **82** withdrawn from the patient. Thus, the prosthesis **20** may be used to substantially isolate the aneurysm **100** from the rest of the blood vessel. The biosensor **14** may then be used to monitor physiological conditions of the patient, such as pressure within the aneurysmal sac **102**, after implantation of the prosthesis **20**. The biosensor **14** may be activated remotely to provide pressure or other data, and thereby facilitate monitoring the condition of an aneurysm to detect early signs of leaks or other potential problems.

[0051] In an alternative embodiment, the prosthesis **20**, mounted to the delivery device **82** in its contracted condition, may be advanced to the aneurysm site **100** over the guidewire **110** before the biosensor device **10** is introduced therein (not shown). The biosensor device **10** may then be advanced into the aneurysm site **100**, as described above, and then positioned around the prosthesis **20** before the prosthesis **20** is expanded towards its enlarged condition.

[0052] Alternatively, the loop **12** may be oriented around the delivery device **82** at its proximal end (not shown) and the biosensor device **10** advanced distally over the delivery device **82** using the catheter **52** until the biosensor device **10** is positioned over the prosthesis **20** at the aneurysm site **100**. The prosthesis **20** may then be expanded, and the biosensor device **10** released, as described above.

[0053] While the invention is susceptible to various modifications, and alternative forms, specific examples thereof have been shown in the drawings and are herein described in detail. It should be understood, however, that the invention is not to be limited to the particular forms or methods disclosed, but to the contrary, the invention is to cover all modifications, equivalents and alternatives falling within the spirit and scope of the appended claims.

What is claimed is:

1. A method for implanting a biosensor within a body lumen of a patient, comprising:

introducing a tubular prosthesis in a contracted state within the body lumen;

introducing a loop within the body lumen, the loop including a biosensor attached thereto;

positioning the loop and the prosthesis coaxially with respect to one another; and

expanding the prosthesis towards an enlarged condition, thereby engaging the loop around the prosthesis.

2. The method of claim 1, wherein the loop is introduced within the body lumen within a lumen of a delivery apparatus, the loop being detachably secured to the delivery apparatus.

3. The method of claim 2, further comprising deploying the loop from the delivery apparatus before positioning the loop around the prosthesis.

4. The method of claim 3, further comprising releasing the loop from the delivery apparatus after positioning the loop around the prosthesis.

5. The method of claim 4, wherein the loop is released from the delivery device after the prosthesis is expanded towards its enlarged condition.

6. The method of claim 1, wherein the step of introducing the loop comprises:

expanding the loop across a treatment site; and

advancing the prosthesis through the loop upon positioning the loop and prosthesis coaxially with respect to one another.

7. The method of claim 1, wherein the body lumen comprises an aneurysm.

8. The method of claim 7, wherein the biosensor is disposed within an aneurysmal sac at least partially defined by the aneurysm after the prosthesis is expanded to its enlarged condition.

9. The method of claim 1, further comprising the step of engaging the prosthesis with a wall of the blood vessel.

10. An apparatus for delivering a biosensor to a treatment site within a body lumen, comprising:

a catheter having a proximal end and a distal end adapted for introduction into the body lumen;

an attachment loop having a biosensor attached thereto; and

a connector on the catheter for detachably securing the attachment loop to the catheter.

11. The apparatus of claim 10, wherein the connector is on the distal end of the catheter.

12. The apparatus of claim 10, wherein the connector is on a side region of the catheter.

13. The apparatus of claim 10, wherein said connector comprises a wire extending through the catheter.

14. The apparatus of claim 10, wherein said connector comprises a pair of opposing mandibles having a slot therebetween for engaging the loop.

15. The apparatus of claim 13, wherein the attachment loop comprises a ring attached thereto for receiving the wire therethrough.

16. The apparatus of claim 10, further comprising:

a tubular prosthesis expandable between a contracted condition for facilitating introduction into the body lumen, and an enlarged condition; and

a delivery device for directing the prosthesis to the treatment site in its contracted condition.

17. An apparatus implantable within a body lumen, said apparatus comprising a loop having a biosensor attached thereto, said loop expandable between a contracted condition and an expanded condition, and said biosensor extending radially outward from the loop.

18. The apparatus of claim 17, further comprising a tubular prosthesis wherein said loop is adapted for coaxial engagement over the tubular prosthesis.

19. The apparatus of claim 18, wherein said tubular prosthesis is expandable between a contracted condition for facilitating introduction into the body lumen, and an enlarged condition for contacting a wall of the body lumen at a treatment site.

20. The apparatus of claim 18, wherein the loop is secured to the tubular prosthesis by friction.

21. An apparatus for monitoring a physical parameter at an aneurysmal site within a blood vessel lumen comprising:

a tubular prosthesis;

a loop having a size for securing the loop coaxially around the prosthesis; and

a biosensor attached to the loop and extending radially outward from the loop.

22. The apparatus of claim 21, wherein the biosensor is a sensor selected from the group consisting of a pressure sensor, a temperature sensor, a pH sensor, a blood sugar sensor, a blood oxygen sensor, a motion sensor, an acceleration sensor, a force sensor, a strain sensor, an acoustics sensor, a moisture sensor, an osmolarity sensor, a light sensor, a turbidity sensor, a radiation sensor, an electromagnetic field sensor, a chemical sensor, an ionic sensor, and an enzymatic sensor.

23. The apparatus of claim 21, wherein the loop comprises a ring or sleeve formed from a substantially elastic material, the ring or sleeve having a relaxed state having a cross-section smaller than the prosthesis.

24. The apparatus of claim 21, wherein the loop is compressible to facilitate its insertion into a delivery device.

* * * * *

专利名称(译)	用于与假体一起部署生物传感器的系统和方法		
公开(公告)号	US20020111543A1	公开(公告)日	2002-08-15
申请号	US10/122015	申请日	2002-04-12
[标]申请(专利权)人(译)	PENNER AVI WOLINSKY LONE		
申请(专利权)人(译)	PENNER AVI WOLINSKY LONE		
当前申请(专利权)人(译)	REMON医疗技术有限公司.		
[标]发明人	PENNER AVI WOLINSKY LONE		
发明人	PENNER, AVI WOLINSKY, LONE		
IPC分类号	A61B5/00 A61B5/0215 A61B5/03 A61F2/02 A61F2/06		
CPC分类号	A61B5/0031 A61B5/02007 A61B5/02014 A61B5/0215 A61B5/036 A61B5/6862 A61B5/6876 A61F2/07 A61F2002/075 A61F2250/0002 A61F2/89		
其他公开文献	US6743173		
外部链接	Espacenet USPTO		

摘要(译)

用于监测动脉瘤部位处的压力或其他物理参数的生物传感器可安装到管状假体上，该管状假体可在收缩和扩大的条件之间扩张。具有附接到其上的生物传感器的环可固定在假体周围。一种装置用于将环递送到动脉瘤部位，该动脉瘤部位包括导管，该导管在其远端具有连接器，用于将环可拆卸地固定到其上。假体在收缩状态下前进到动脉瘤，并且具有连接到其上的环的装置前进到动脉瘤部位。环和假体相对于彼此同轴定位，并且假体朝向其扩大状态扩张，从而使环绕假体接合并使假体与治疗部位处的血管壁接合。

